

# Optimization study of using PTC for human body heating dissipation

Tiberiu Adrian SALAORU<sup>\*.1</sup>, Marina ANDREI<sup>1</sup>, Ilinca NASTASE<sup>2</sup>

\*Corresponding author

<sup>\*.1</sup>INCAS – National Institute for Aerospace Research “Elie Carafoli”

B-dul Iuliu Maniu 220, Bucharest 061126, Romania

salaoru.tiberiu@incas.ro

<sup>2</sup> Technical University of Civil Engineering in Bucharest,

Building Services Department, CAMBI Research Center

66 Pache Protopopescu Av., Bucharest 021414, Romania

ilinc.nastase@gmail.com

DOI: 10.13111/2066-8201.2014.6.2.8

**Abstract:** *A better knowledge of the human body heat losses mechanisms is important for both diminishing the number of deaths during the surgical procedures of the patients under effect of full anaesthesia and increasing the efficiency of the Heating, Ventilation and Air Conditioning (HVAC) systems. For these studies it is necessary to manufacture a human body mannequin having its surface temperature maintained on a value close to the real human body temperature. A number of PTC (Positive Temperature Coefficient) thermistors placed on the entire external surface of the mannequin can be used for this purpose. This paper presents a study of the transient heating regime and the stability of the maintained temperature, performed on these devices.*

**Key Words:** *PTC, thermistors, thermal mannequin, temperature stability*

## 1. INTRODUCTION

Heating Ventilating Air Conditioning (HVAC) systems have to ensure clean air and comfortable conditions for their users. This is resulting in a real dilemma for the conceivers of building systems and services which are divided between keeping up with air quality standards and reducing energy consumption. We can notice that current air distribution techniques are not optimised for complying simultaneously on these two opposite objectives: thermal comfort and energy savings.

This problem is quite critical in the case of cooling, when the cold air trends to descend in the occupied area due to the gravitational forces effect. This way, if in the hot season air conditioning systems are intended to offer a better comfort to the occupants, they are often complaining of “cold”, “draught sensation” and sore throat. This paradox is due to the lack of performance of the cold air diffusion in the conditioned room related to a mixing problem between the cooling air and the hot ambient air.

Despite of these inconveniences, the air conditioning become vital in some situations, mainly due to the hot summers from the past few years in Europe, where the broad use of the air conditioning resulted in increased energy consumption by over 60% as compared to that recorded in 2003.

In our opinion, a technical solution to this problem can be found at the design level of the air diffusion Terminal Units which needs to be optimised relatively to the ambient air induction. The proposed idea concern the improvement of the air diffusion grilles from the

point of view of the mixing between the cold or hot air with the ambient air.

In the same time, it is still not acknowledged that convection flows caused by heat sources like the human body plume may significantly affect the flow distribution in inhabited rooms [1]. Generally, attention is given only on the flow generated by the air diffusion terminal devices.

As shown by Kosonen et al [1] the point of occurrence of the maximum air velocity in the occupied zone depends on the heat source strength and its distribution in the room. Thus, the air flows interaction itself is of great importance when estimating occupants' comfort.

Numerical investigations such as those accomplished by Computational Fluid Dynamics have been gaining immense popularity within the HVAC industry since the last few decades. A series of CFD type studies are present in the literature, offering a diversity of human body models, from the most complex geometries to the simplest ones.[2-4]. The computer power processing development has allowed performing an important number of numerical studies where the human body is defined as close as possible to its real shape.

The results show that the latter are the most efficient in terms of correct ambient flows predictions, thermal comfort and air quality. The specific parameters, such as shape, size, metabolism, dressing level or activity can influence the thermal perception of the internal environment [5].

In the same time, results obtained from computational fluid dynamics (CFD) need to be validated with experimental data from real scale measurements before using CFD for larger parametric investigation.

Experimental campaigns using human subjects are quite expensive, time consuming and may be difficult to validate. Some of the experimental approaches, such as PIV measurements, are impossible to achieve due to safety issues. A good compromise is the use of the thermal manikins to simulate the human body, in a more or less realistic manner as a heat source [6-8].

In this context, in the EQUATOR [9] project frame, we want to extend the development by own means of some relatively low cost thermal mannequins prototypes. A series of five previous prototypes has been elaborated at the Technical University of Civil Engineering of Bucharest [5-8].

In general, the thermal mannequin should be shaped as a real adult person, and its surface divided in distinct areas [7] which should be maintained as close as possible to a human body temperature distribution.

Thus, it is necessary that some areas be slightly different in terms of temperature from other areas, requiring strict control of these values [14].

To reach this target one of the possible methods is to use thermistors with Positive Temperature Coefficient (PTC).

These devices can be placed on the external surface of the mannequin and powered from a constant voltage power supply.

The characteristics of this type of thermistor give them the possibility of temperature self-adjusting when supplied with a constant voltage value. For a uniform heating of the external surface of the mannequin it is necessary that the heated surfaces are as much as possible continuous, without gaps larger than few millimetres.

Because the shape of these thermistors can not completely cover a surface, it is necessary to place them on plates made of a high thermo conductivity material and having the shape adapted to the curved surfaces of the mannequin. This paper presents a series of preliminary studies for evaluation of the possibility of an adequate use of PTC for the conception of thermal mannequins.

## 2. SYSTEM DESCRIPTION

For testing the maintained temperature stability and variation of the consumed power this type of thermistors was placed on a rectangular shaped aluminium surface.

The block diagram of the measurement system is shown in Figure 1.

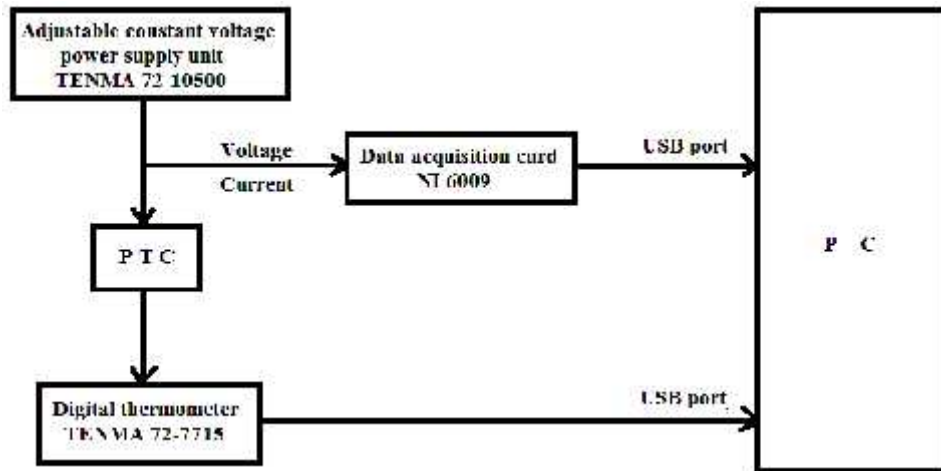

Figure 1. Block diagram of the measurement system

The constant voltage is supplied by one channel of the dual channel adjustable voltage power supply TENMA 72-10500, 30V/3A. This voltage is applied to the thermistor to be tested and to the AI0 analogue input of the NI6009 data acquisition card made by National Instruments. A voltage proportional to the electrical current intensity flowing thru the PTC-type thermistor is applied on the analogue input of the same data acquisition card. The thermistor plate's temperature is measured using a digital thermometer TENMA 72-7115 by means of a K-type thermocouple. The data referring to voltage, current intensity thru PTC and the temperature of the PTC plate are sent thru two USB ports for data acquisition and processing.

Two PTC thermistors, HP03 1/04 made by DBK Technitherm Ltd. (Figure 2a) [9] and A60 B59060A0040A010 made by EPCOS (Figure 2b) [10] have been used for testing.

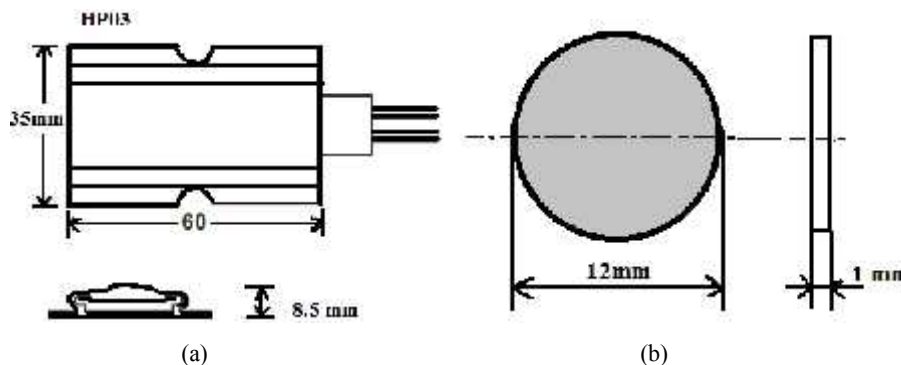

Figure 2. PTC dimensions HP03 1/04 (a) and A60 B59060A0040A010 (b)

Each thermistor has been mounted on a 100 x 100mm square shaped aluminium plate having 1.5mm of thickness. Figure 3 shows the manner of fastening of the HP03 1/04 thermistor on this aluminium plate.

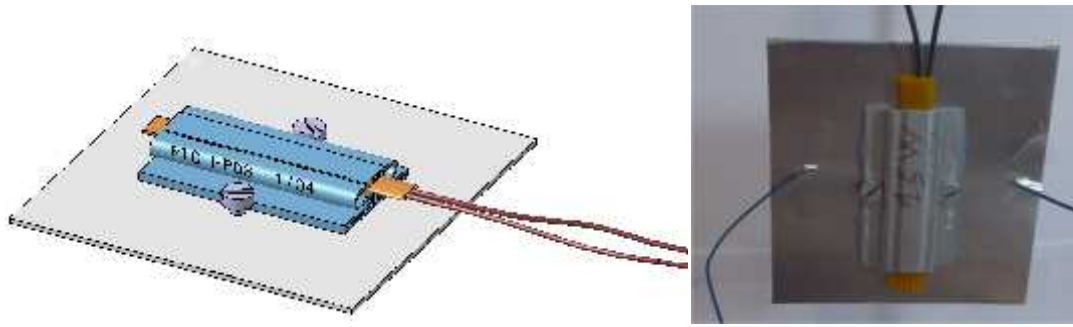

Figure 3. HP03 1/04 thermistor mounted on aluminium plate

Two thermocouples connected to TENMA 72-7715 thermometer have been attached on this plate for temperature monitoring.

As can be seen in Figure 2b, the A60 B59060A0040A010 thermistor has a disk shape with 12mm diameter and 1mm thickness, requiring a system of fastening to the aluminium plate, shown in Figure 4.

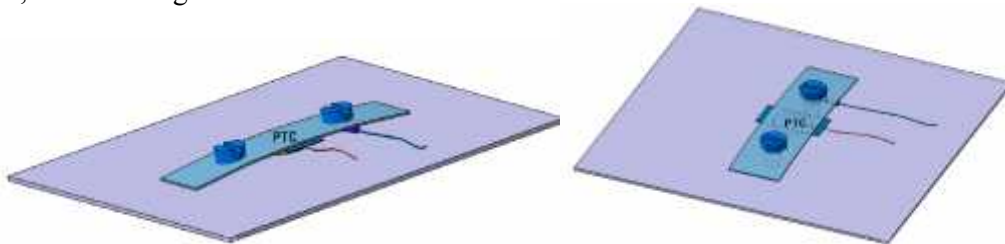

Figure 4. A60 B59060A0040 thermistor mounted on aluminium plate

The thermistors connection to the electrical circuit for testing was performed according to the scheme shown in Figure 5.

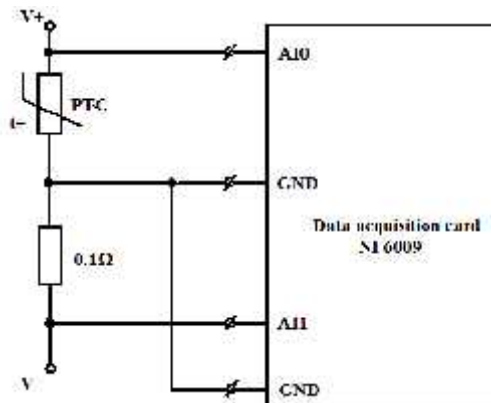

Figure 5. Circuit diagram for PTC testing

The AI0 channel of the data acquisition card is used for measuring the voltage applied to the thermistor, the measurement range being set between 0 – 10 V and the channel AI1 being used to measure the dropping voltage on the resistor connected in series with the thermistor. The measurement range of this channel is set in the range of 0 – 1V.

This dropping voltage has a numerical value equal to 1/10 of the electrical current value measured in amps which is passing thru the thermistor. The power supplied to the thermistor

is calculated by multiplying the voltage and the applied current values in a Labview code which is also used for data acquisition and storage.

### 3. TESTING PROCEDURE

Tests have been performed by applying a constant voltage of 4.5, 5.5, 6.5, 7.5 and 8.5 V to each thermistor. The electrical current intensity and the temperature of the PTC plate have been captured for each value. For each test, have been acquired/ These values have been captured for each test during an interval of 30 minutes with a frequency of 1Hz.

The duration of each test and the frequency of acquisition were chosen so that the system have enough time to reach the thermal equilibrium and the measurements to be sufficiently frequent to describe the variations in the measured values as well.

During the whole duration of the tests, the working area has been isolated as much as possible from the air drafts to prevent perturbation of the measurement results and the ambient air temperature has been maintained constant to a value of 23°C.

### 4. RESULTS AND DISCUSSIONS

The experimental results for the A60 B59060A0040A010 thermistor are shown in Figures 6 and 7. Figure 6 shows the time variation of the device temperature.

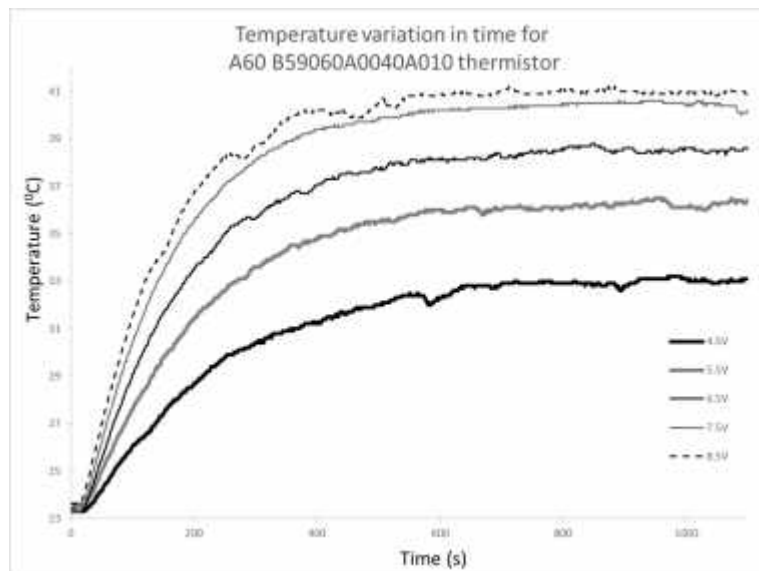

Figure 6. Temperature variation for A60 B59060A0040A010

Changes in temperature of the thermistor results in a change in its resistance which causes a variation in the intensity of current there through while the power supply voltage is kept constant at its terminals. The increase in temperature causes an increase in the electrical resistance which will result in a decrease in the intensity of the current through the thermistor. This will determine a decrease of the dissipated power on the PTC device which will slow down the temperature rising.

If the consumed power of the device will have an equal value as the dissipated power into environment, its temperature will be stabilised around a fixed value determined by the voltage applied to the device. In this way, the PTC thermistor will behave as a temperature

self regulating device. Figure 7 presents the variation in time of the electrical power consumed by the thermistor.

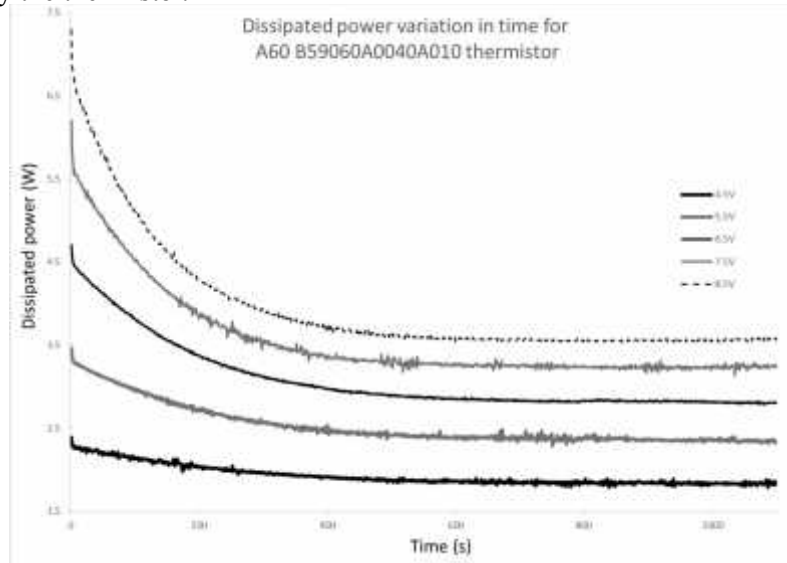

Figure 7. Power dissipation variation for A60 B59060A0040A010

A close correlation can be noticed between the consumed power variation in time of the device and its temperature which confirms the working principle of the PTC thermistor. After about 500s the device temperature and consumed power are stabilizing around constant values. These values increase with the applied voltage value.

The distances between the curves shown in figure 7 are getting smaller and smaller with the increasing in voltage and in the equilibrium temperature, implicitly. Similar behavior was observed for the HP03 1/04 thermistor whose temperature variation curves (Figure 8) and power dissipation (Figure 9) are similar in shape to those of the A60 thermistor B59060A0040A010 the only differences being the corresponding applied voltage values.

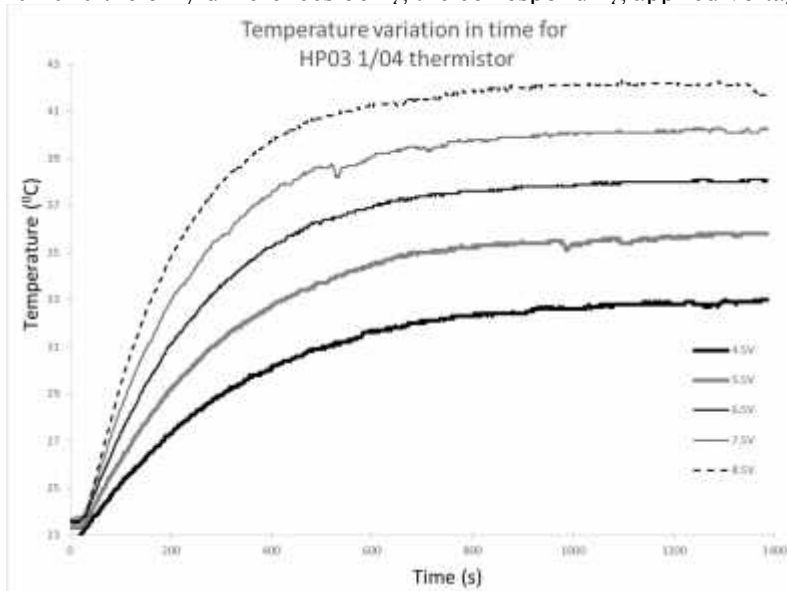

Figure 8. Temperature variation for HP03 1/04

From the behavior of both thermistors, we find that it takes a rather long time to stabilize the temperature, of about 10 minutes, starting from room temperature. This time value is expected to increase with the mass of the plate on which the thermistor is mounted and with the environmental conditions (lower ambient temperature, air currents and high humidity). Also fluctuations in the values around the equilibrium temperature were found in some small intervals of time especially due to the emergence of accidental air currents, but these fluctuations had acceptable averages values about  $\pm 0.1^{\circ}\text{C}$ .

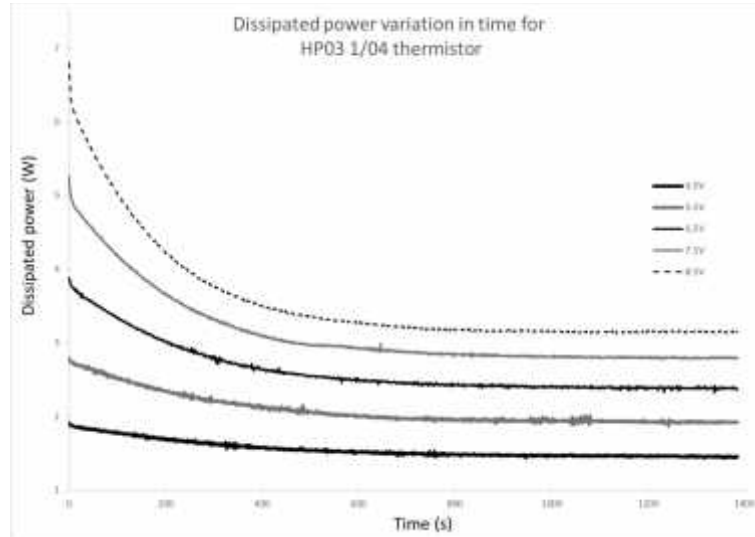

Figure 9. Power dissipation variation for HP03 1/04

## 5. FUTURE DIRECTIONS OF DEVELOPMENT

A practical solution for reducing the relaxation time of the thermistor required for reaching the equilibrium temperature and for improving the temperature stability in time will be connecting this type of thermistor to a more complex circuit, where the voltage supply will be controlled by another device during transient processes, maintaining it constant only during the thermal equilibrium. This device can be made using a combination of some other PTC or NTC (Negative Temperature Coefficient) thermistors using an electronic control circuit operating according to a control law which will also take into account the environmental conditions.

## 6. CONCLUSIONS

This paper presents a series of preliminary studies to evaluate the judicious use of PTC devices for making thermal mannequins. They can be mounted in a convenient way on the external surface of the mannequin and supplied from a stabilised voltage power supply. The characteristics of this type of thermistor give them a self regulating temperature feature when supplied with constant voltage.

The temperature stability of this type of device and the possibility to improve it by combining it with other circuit components recommend the PTC thermistor as a useful component for keeping constant temperature of the external surface of mannequins used for studying of the heat losses of human body exposed to different environmental conditions.

## ACKNOWLEDGEMENTS

This work was supported by the grant of the Romanian National Authority for Scientific Research, CNCS – UEFISCDI, project numbers: PN-II-PT-PCCA-2011-3.2-1212.

## REFERENCES

- [1] R. Kosonen, et al., *Impact of heat load location and strength on air flow pattern with a passive chilled beam system*, *Energy and Buildings*, ISSN: 0378-7788 **42**(1): p. 34-42, doi: 10.1016/j.enbuild.2009.07.008, 2010.
- [2] D. N. Sorensen and L. K. Voigt, *Modeling airflow and heat transfer around a seated human body by computational dynamics*, *Building and Environment*, ISSN: 0360-1323, **38**(6): p. 753-762, 2003.
- [3] S. Murakami, S. Kato and J. Zeng, *Combined simulation of airflow, radiation and moisture transport for heat release from a human body*, *Building and Environment*, ISSN: 0360-1323, **35**(6): p. 489-500, 2000.
- [4] S. Murakami, S. Kato and J. Zeng, *CFD analysis of thermal environment around human body*. *Indoor air '96*, **2**: p. 479-484, 1996.
- [5] C. Croitoru, et al., *Numerical and experimental modeling of airflow and heat transfer of a human body*. in Roomvent 2011 Conference, Trondheim, Norway.
- [6] A. Dogeanu, et al., *Conception of a simplified seated thermal manikin for CFD validation purposes*. *Romanian Journal of Civil Engineering*, 2013, (december 2013).
- [7] A. Dogeanu, et al. *Conception of an advanced thermal manikin for thermal comfort assessment in buildings and vehicles*. in Young Researchers Conference 2013, UTCB, 2013.
- [8] I. A. Cruceanu, *Studiul mișcării aerului în sistemele de ventilare personalizate*, Thesis, UTCB. 2013.
- [9] \*\*\*, ISO 9972 :2006 Thermal performance of buildings - Determination of air permeability of buildings - Fan pressurization method.
- [10] \*\*\*, *HP Series of PTC Heaters, datasheet catalog*,  
<http://www.dbktechnitherm.ltd.uk/brochures/hpebht/Overview.pdf>,  
<http://www.farnell.com/datasheets/477436.pdf>