

SIMULATION RESULTS OF DOUBLE FORWARD CONVERTER

P. VIJAYA KUMAR¹, Dr. S. RAMA REDDY²

¹Research Scholar, Jawaharlal Nehru Technological University, Hyderabad, India.

²Professor, Jerusalem College of Engineering, Chennai, India.

E-mail : dvvijayaharini@rediffmail.com, srr_victory@yahoo.com

Abstract: This work aims to find a better forward converter for DC to DC conversion. Simulation of double forward converter in SMPS system is discussed in this paper. A forward converter with RCD snubber to synchronous rectifier and/or to current doubler is also discussed. The evolution of the forward converter is first reviewed in a tutorial fashion. Performance parameters are discussed including operating principle, voltage conversion ratio, efficiency, device stress, small-signal dynamics, noise and EMI. Its circuit operation and its performance characteristics of the forward converter with RCD snubber and double forward converter are described and the simulation results are presented

Keywords: Forward converter with a RCD snubber, Forward converter with a LCDD snubber, Forward converter with a resonant switch, Forward converter with a switching snubber, Synchronous rectifier, Current doubler.

1. INTRODUCTION

The forward converter remains as an industry workhorse in low-power DC/DC conversions. Recent development has significantly enhanced the performance and, in the mean time, increased the number of forward topologies that are available for a designer to choose from. Hence, selecting a best suitable forward topology for a given application becomes an important and challenging task.

This paper presents a simulation of results of the forward converter. It is intended for design engineers who desire to be a successful in a first implementation of a design and to meet the increasingly demanding spec, budget, and schedule requirements.

Topologies selected here are based on one criterion: whether or not a topology is used in industry applications. Personal preference also plays a role.

Section 2 presents an account of the evolution of the forward converter. The account follows the

technology development of the forward. It starts with the classic forward and leads all the way to the contemporary topologies, including the forward/flyback converter and the double forward converter. For each topology, key design quantities are summarized together with respective strengths and weakness. Section 3 is a simulation results and compare the performance of the system and the basic topologies to include synchronous rectifier and the current doubler.

2. EVOLUTION OF THE FORWARD CONVERTER

Discussion is focused on those forward topologies that are widely used in industry. It follows the line of technology development, using the reset mechanism as a common thread. Rather, it focuses on important design aspects such as reset mechanism, voltage conversion ratio, and device stresses.

A. The Classic Forward Converter

Circuit (a) in Figure 2 is the classic forward converter. The basic operation is well known (Severns and Bloom, 1985; Dong Tan, 1996; Severns, 2000; Bhat, and Dong Tan, 1989; Dong Tan, 2001).

When the switch M is turned on, a positive voltage is applied to the primary of the transformer. By the action of the transformer a proportional voltage appears on the secondary. This voltage biases diode D_1 into conduction, forwarding power to the output. A low pass filter, formed by L_f and C_f , recovers the DC voltage and attenuates switching ripple. Adjusting the duty ratio, defined as the on time over switching period, regulates output voltage.

When M is turned off, an auxiliary winding resets the transformer through diode D. For the same number of turns, a common choice, the duty ratio is $<50\%$. The voltage conversion ratio is $n \cdot d$, where d is the duty ratio and $n = N_s/N_p$ the transformer turns ratio. Voltage stress on the MOSFET is typically $2.6V_{in,max}$. This is considered high and it limits the performance of the converter, especially when the input voltage is high (e.g., for off line applications).

B. The Forward Converter with a RCD Snubber

Circuit (b) of Figure 2 is an early attempt in improving reset. It uses a RCD network to reset the transformer, and hence known as the forward converter with a RCD snubber (See, for example, Clemente *et. al.*, 1985; Leu *et. al.*, 1992, for more details). The cost of this approach is low. It remains a good choice for low cost designs.

The main power forwarding is the same as in the classic and the voltage conversion ratio is $n \cdot d$. When M is turned off, a diode D and a capacitor C clamp the voltage to a level determined by the input voltage and duty ratio. A resistor R resets the capacitor. The voltage stress on the MOSFET is typically $2.0V_{in,max}$.

A major disadvantage is that R dissipates power. This dissipation not only reduces efficiency, but also creates a thermal design problem. This is particularly true for offline converters, since the power dissipation in the resistor is proportional to input line.

C. The Forward Converter with a LCDD Snubber

Circuit (c) of Figure 2 is an attempt that uses a lossless snubber to reset the winding. It recovers part of the energy dissipated in the previous scheme by the resistor (See, for example, Cronin and Biess, 1971; Domb *et. al.*, 1984; Wittenberg, *et. al.*, 1992). It uses an inductor, a capacitor and two diodes. Hence, it is known as a LCDD snubber. The main power forwarding is the same as in the classic and the voltage conversion ratio is $n \cdot d$.

When M is turned off, a diode and a capacitor clamp the drain-source voltage in the same manner as in the case of a RCD snubber. Reset of the capacitor is accomplished through a LC resonance formed by L_r , C_r , and D_{c1} . The voltage stress on the MOSFET is typically $2.0V_{in,max}$. By the nature of resonance, multiple modes of operation exist. Because of this, excessive design iterations are needed to ensure proper operation over all load, line, and transient conditions.

Designers often find out that, while this technique controls the drain-source voltage well at turn-off, it offers elusive efficiency improvement. The reason is that the added conduction loss by the resonance can easily eat up the saving of the "lossless" snubber.

Another disadvantage is that the size of L can be large when the input voltage is high. This limitation is particularly severe for offline applications.

D. The Forward with a Resonance Reset

The circuit (d) of Figure 2 utilizes parasitic capacitance(s) to accomplish reset (See Murakami and Yamasaki, 1998; Cobos *et. al.*, 1994). This is a simple, yet effective approach. No additional parts are needed. The main power forwarding is the same as in the classic and the voltage conversion ratio is $n \cdot d$. At turn-off, the magnetizing inductance and an equivalent parasitic capacitance form a resonance, resetting the transformer "automatically". Because of its resonant nature, the voltage stress on the MOSFET is typically $2.0V_{in,max}$.

Disadvantages are that external capacitance is normally needed in order to have a well-defined resonant frequency and stress is still high when compared to some of the later techniques. Also, it is hard to maintain the optimal reset condition over all line and load conditions.

E. The Forward with Two Switches

Circuit (e) of Figure 2 takes advantages of the rapidly falling price of MOSFETs (Wolf, 1973). It uses two switches to connect and disconnect the primary of the transformer to the input source. The main power forwarding is similar to the classic and the voltage conversion ratio is $n \cdot d$. At turn-off, two diodes connect the primary to the input, but in a reversed polarity, resetting the winding "automatically". Because of the clamping action, the voltage stress on the MOSFET is typically $1.0V_{in,max}$. This is the lowest in all the topologies discussed here, a unique feature.

Disadvantages are the need for an additional MOSFET and a high-side gate drive.

F. The Forward Converter with a Switching Snubber

Circuit (f) of Figure 2 uses a switching snubber, otherwise known as an active clamp, to reset the transformer. The main power forwarding is the same as in the classic and the voltage conversion ratio is n.d. Furthermore, zero-voltage allows a lossless snubber to be used at turn-off. The auxiliary switch M_2 is also switched with zero voltage (0.7V) at turn-on and with a favorable condition at turn-off.

This scheme needs an additional MOSFET (and its associated gate drive). Also, this scheme increases the conduction loss by 30-50 %, since a small magnetizing inductance has to be used. What is more problematic is that such converters were observed to experience the so-called "Sub harmonic oscillation" or "lock-up mode" during large signal transients (Carsten, 1981; Carsten, 1990), hindering wide industry applications.

G. The Forward/Flyback

Circuit (g) of Figure 2 is a scheme that combines a switching snubber with a hybrid converter called forward/flyback. The hybrid mode of operation of a forward converter, where the principle of operation and small-signal dynamics were discussed in detail. The key is to introduce an air gap in the core of the transformer, allowing energy to be stored in the air gap during the main power forwarding.

Disadvantages are the need for an additional MOSFET (and its associated gate drive). Similar to the case of a switching snubber, a notorious lock-up mode can exist, causing serious reliability problems. Also, the lock-up mode prevents wide application of this otherwise useful technology. In addition, the reverse recovery of the output diodes is not fully addressed.

H. The Double Forward Converter

Circuit (h) in Figure 2 is a further development, which eliminates the two remaining undesirable features of the forward/flyback converter. The lock-up mode of operation and the reverse recovery of diodes. This makes this technology robust and the paves the way for wide industry application. The reverse recovery of the diodes is fully controlled by the introduction of saturable reactors, SR_1 and SR_2 , and a freewheeling diode D_3 . The freewheeling diode D_3 also prevents the transformer from being short-circuited during the transition of MOSFET drain-source voltage, allowing the entire magnetizing energy to be available for soft switching. This broadens the range of soft switching to the entire range of load.

Disadvantages are the need for a MOSFET (and its associated gate drive), one freewheeling diode, and two saturable reactors.

The above literature does not deal with modeling and simulation of double forward converter. This work aims to develop a model for the forward converter with RCD snubber and to the double forward converter to determine the performance characteristics of the System.

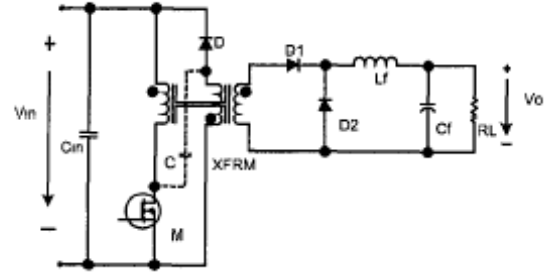

Fig. 2.a. The forward converter with a reset winding.

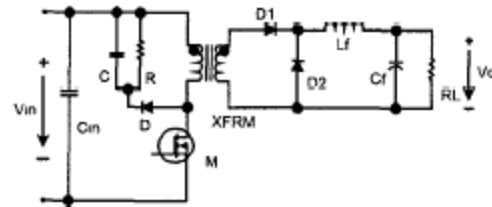

Fig. 2.b. The forward converter with an RCD snubber.

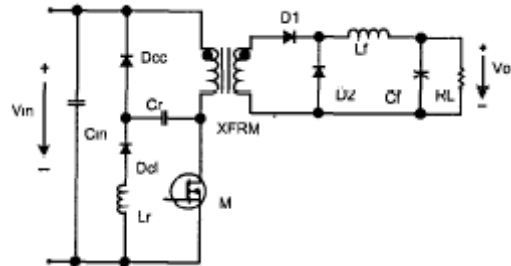

Fig. 2.c. The forward converter with an LCDD snubber.

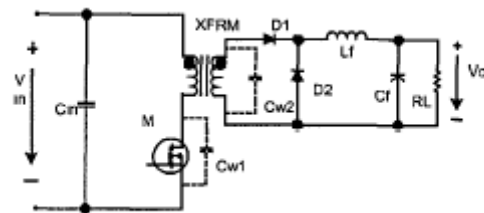

Fig. 2.d. The forward converter with a resonant reset scheme.

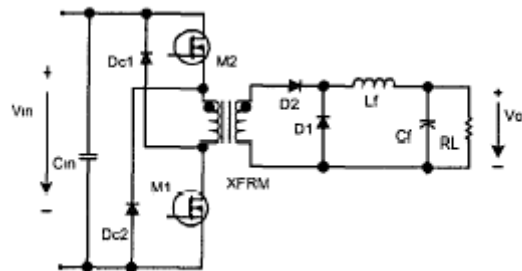

Fig. 2.e. The forward converter with two switches.

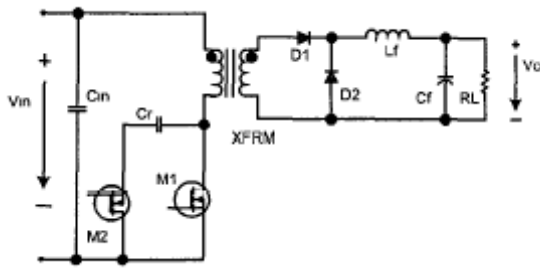

Fig.2.f.The forward converter with a switching snubber.

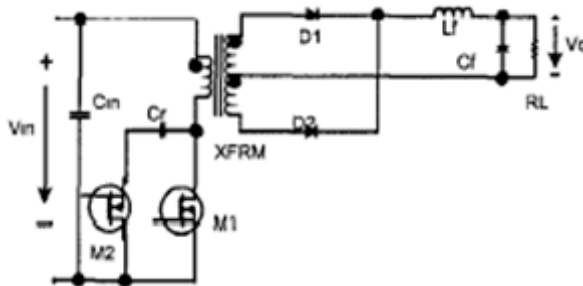

Fig.2.g.The forward/flyback converter.

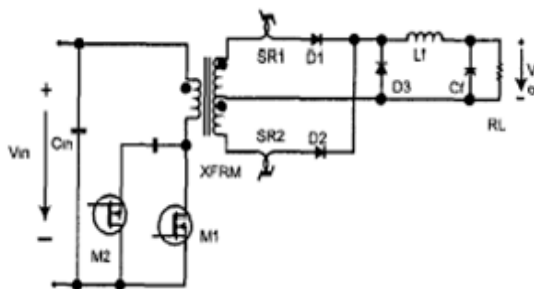

Fig.2.h.The double forward converter.

3. SIMULATION RESULTS

The forward converter with RCD snubber circuit is modeled and simulated using the blocks of MATLAB SIMULINK. The forward converter with RCD snubber is shown in Fig.3.a. The input voltage is shown in Fig.3.b. The driving pulses for switch M are shown in Fig.3.c. The voltage across the switch M is shown in Fig.3.d. It can be seen that the voltage across MOSFET is a compliment of the input. Voltage across the primary of the transformer is shown in Fig.3.e. The voltage across the secondary of the transformer is shown in Fig.3.f. From the output of the transformer, it can be seen that the output is an alternating square wave. The output voltage across the load is shown in Fig.3.g. The output current in the load is shown in Fig.3.h. From the waveforms it can be seen that the load operates at low voltage and high current.

Modified forward converter using synchronous rectifier and current doubler is shown in Fig.4.a.D.C

voltage applied to the primary of the transformer is shown in Fig.4.b. The driving pulses for switches M1 and M2 are shown in Fig.4.c. The voltage across the switch M1 is shown in Fig.4.d. It can be seen that the input and output are compliment of each other. The voltage across the switch SR2 is shown in Fig.4.e. Voltage across the primary of the transformer is shown in Fig.4.f. The voltage across the secondary of the transformer is shown in Fig.4.g. Thus forward converter converts DC into AC. The output voltage across the load is shown in Fig.4.h. The output current in the load is shown in Fig.4.i.

The comparison between the input voltage and the output voltage in RCD and synchronous rectifier is shown in Fig.5.a. The comparison between the input voltage and the output power in RCD and synchronous rectifier is shown in Fig.5.b. From the above waveforms, it can be seen that the output power is higher in double forward converter when compared with the RCD snubber system.

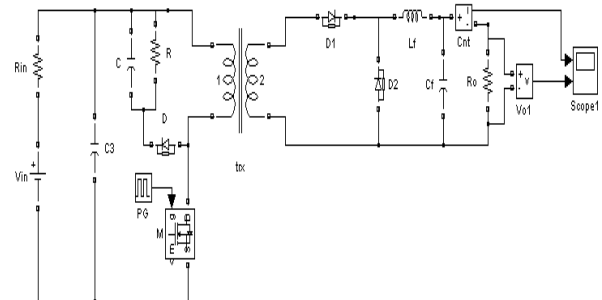

Fig.3.a.Forward converter with RCD snubber.

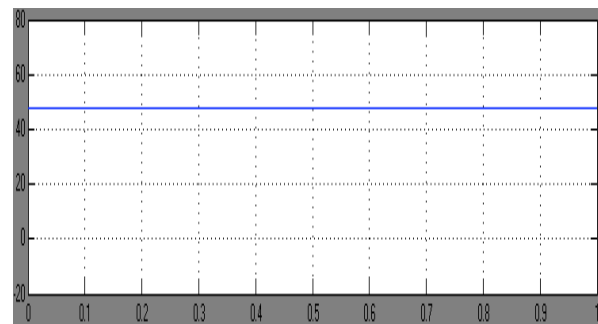

Fig.3.b Input voltage.

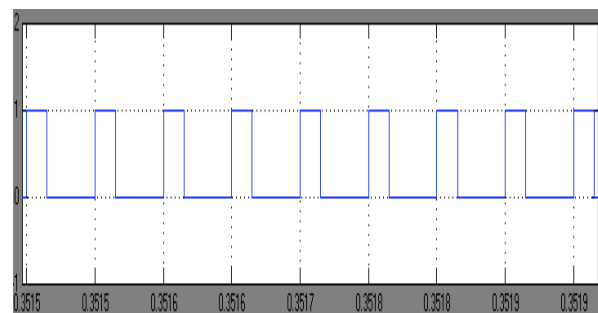

Fig.3.c.Driving pulses for switch M.

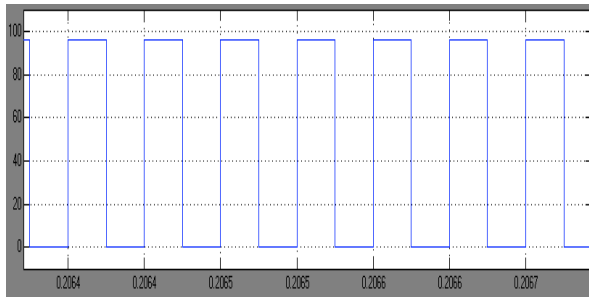

Fig.3.d.Voltage across switch M.

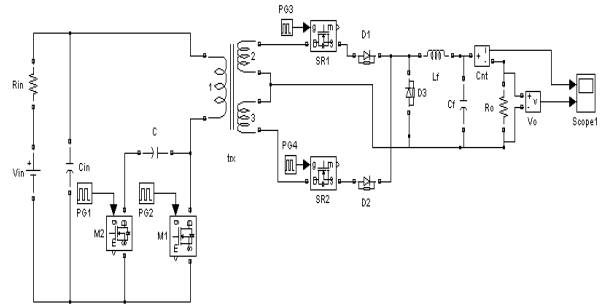

Fig.4.a.Double forward converter.

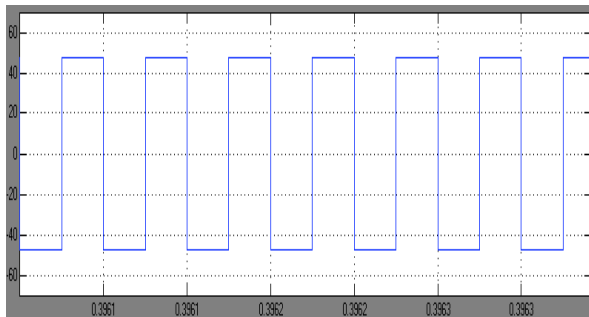

Fig.3.e.Transformer primary voltage.

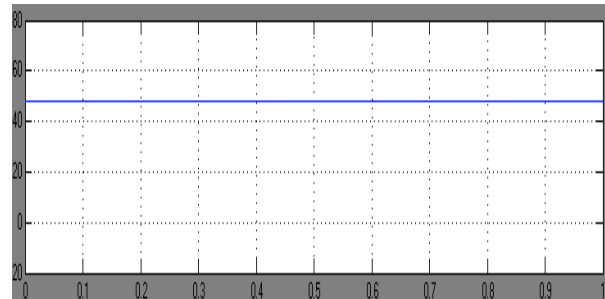

Fig.4.b.Input voltage.

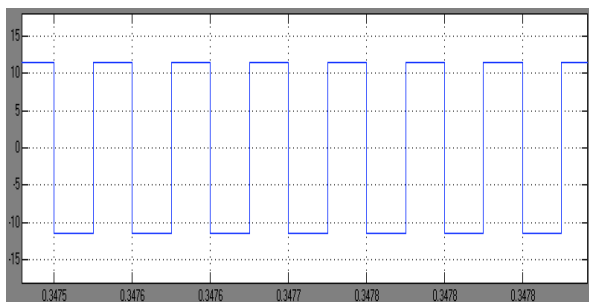

Fig.3.f.Transformer secondary voltage.

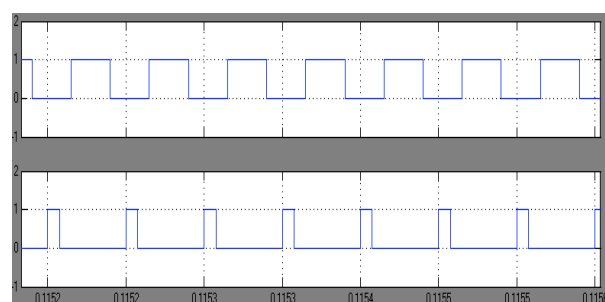

Fig.4.c.Driving pulses for switches M1, M2.

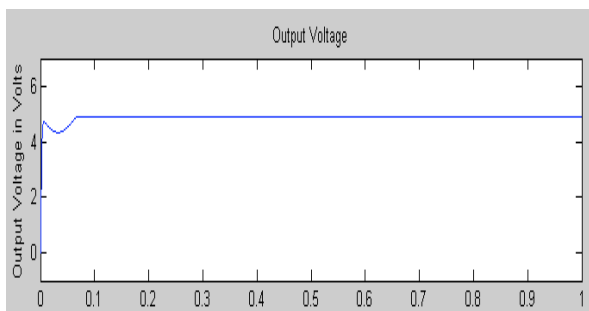

Fig.3.g.Output voltage.

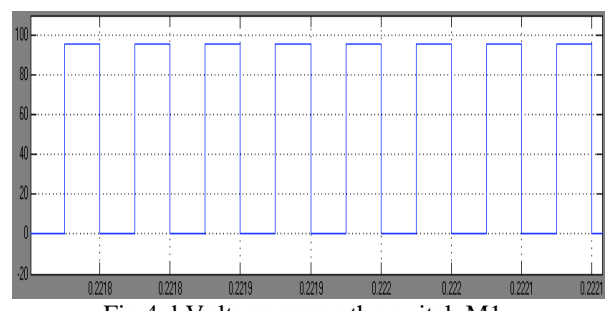

Fig.4.d.Voltage across the switch M1.

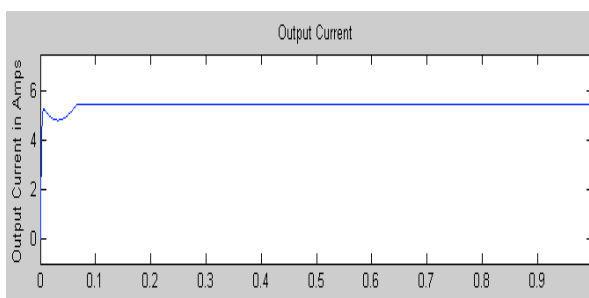

Fig.3.h.Output current.

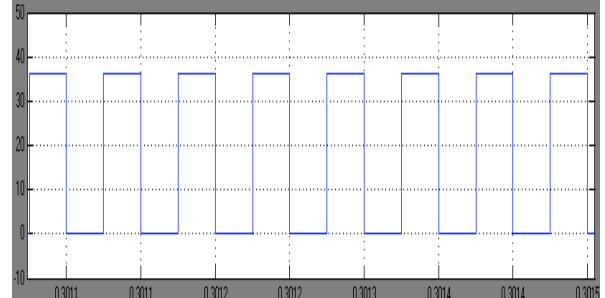

Fig.4.e.Voltage across the switch SR2.

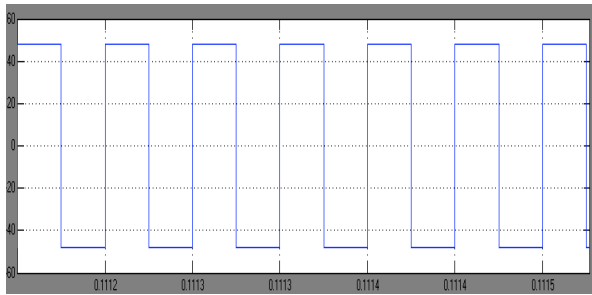

Fig.4.f. Transformer primary voltage.

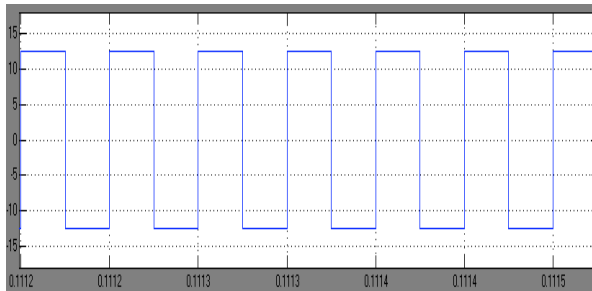

Fig.4.g. Transformer secondary voltage.

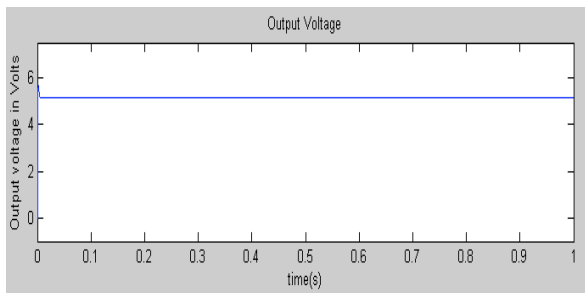

Fig.4.h. Output voltage.

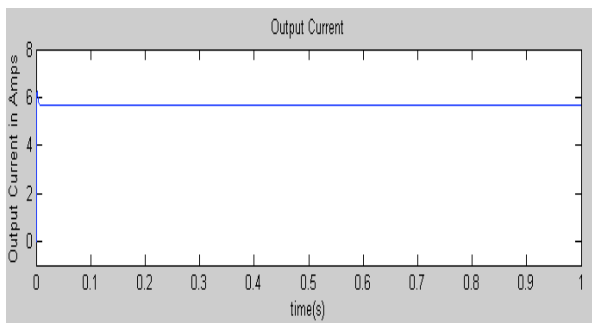

Fig.4.i. Output current.

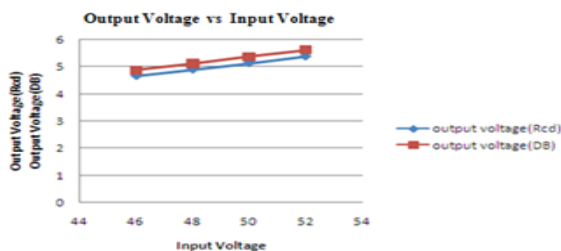

Fig.5.a. Output voltage versus Input voltage.

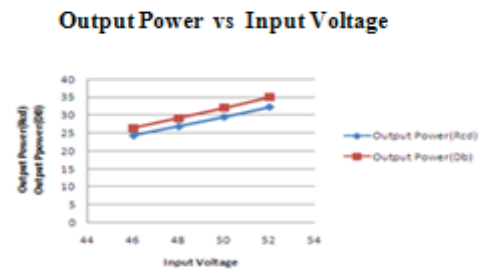

Fig.5.b. Output Power versus Input Voltage.

4. CONCLUSION

The evolution of the forward converter with its working principle is presented in this paper. The forward converter with RCD snubber and the Double forward converter are digitally simulated using Sim power systems. From the simulation results, it is observed that the output power of double forward converter is high when compared with the RCD snubber system. Therefore double forward converter is better than other forward converters.

5. REFERENCES

- Severns, R., Bloom, E. (1985) *Modern DC-to-DC Switched-Mode Power Conversion Circuits*, Van Nostrand Reinhold.
- Dong Tan, F. (1996) *Basic Circuits in Power Electronics* (Course Notes for EE 166), Department of Electrical and Computer Engineering, University of California at Irvine.
- Severns, R. (2000) The history of the forward converters, *Switching Power Magazine*, Vol. 1, No.1, pp.20-22.
- Bhat, A.K.S., Dong Tan, F. (1989) A unified approach to characterization of PWM and quasi-PWM switching converters: topological constraints, classification, and synthesis, *IEEE Transaction on Power Electronics*, Vol.6, No.4, pp.719-725.
- Dong Tan, F. (2001) The forward converter: from the classic of the contemporary, *IEEE APEC'01 Seminar #6*.
- Clemente, S., Pelly, B., Ruttonsha, R. (1985) A universal 100 KHZ power supply using a single HEXFET, *International HEXFETs Data book*, pp.A99-A110.
- Leu, C.S., Hua, G., Lee, F.C, Zhou, C. (1992) Analysis and design of RCD clamp forward converter, *HFPC Proceedings*, pp.198-208.
- Cronin, D., Biess, J. (1971) *Non-dissipative power loss suppression circuit for transistor controlled power converters*, US Patent # 3,628,047.

- Domb, M., *et al.* (1984) Non-dissipative turn-off snubber alleviates switching power dissipation, second-break down stress and Vce overshoot: analysis, design procedure, and experimental verification, *IEEE PESC Record*, pp.445-454.
- Wittenberg, *et al.* (1992) A duty cycle extension technique for single ended forward converters", *IEEE APEC Proceedings*, pp.51-57.
- Murakami, N., Yamasaki, M. (1998) Analysis of a resonant reset condition for a single-ended forward converter", *IEEE APEC Record*, pp.1018-1023.
- Cobos, J.A. *et al.* (1994) Resonant reset forward topologies for low output voltage on board converters", *IEEEAPEC Proceedings*, pp.703-708.
- Wolf, G. (1973) Mains isolating switching-mode power supply, *Philips Electronic Application Bulletin*, Vol.32, No.1.
- Carsten, B. (1981) High power SMPS require intrinsic reliability, *Power Conversion International Proceedings*, pp.118-133.
- Carsten, B. (1990) Design techniques for transformer active reset circuit at high frequencies and power levels, *HFPC Proceedings*, pp.235-245.