

## The Conception of the General Content of the Composition, Structure and Working of the Informative Components of the Economic Knowledge Base

Tudor St. LEAHU

Cooperative Trade University, Chişinău, Republic of Moldova

[leahu.ts@mail.ru](mailto:leahu.ts@mail.ru)

*Starting of the content aspect, on the systematic-informational positions, the general conceptional variant of the composition, structure and transformative relations of elements of the informative compartment of knowledge base (K.Bs.) of automatized banks of economic intelligent data (A.Bn.E.Ig.D.) arent to clear*

**Keywords:** general composition, structure, working, informative components, knowledge base.

### Content

According to [1], [2], by the analogy of automatized banks of economic informative data (A.Bn.E.Iv.D.) together with the automatized banks of economic intelligent data (A.Bn.E.Ig.D.), has been established that the last, like the first one, contains two basic functional compartments – programmatic (P.C.) and informational (I<sub>1</sub>.C.). In its turn, the first consists of two architectural levels, the first level taking in the economic expert system (E.E.S.), the second – the economic data-base management system (E.D.B M.S.). At the same time, the informational compartment of A.Bn.E.Ig.D. comprises the economic unitary knowledge base (E.U.K.Bs.) and the economic informative data-base (E.Iv.D.B.).

Further, the next P.C. level consists of various categories of systematic programmed resources (S.P.R.) and applied programmed resources (A.P.R.), while the next I<sub>1</sub>.C. level – respectively from the totality of coditions, rules (C.,R.) and decisional products (D.P.) comprised in content of the E..U.K.Bs., collections of economic primary informative data (C.E.Pr.Iv.D.) and collections of economic informational informative products (C.E.I<sub>1</sub>.Iv.P.) comprised in the composition of the E.Iv.D.Bs.

At the level of internal informatics organizational structures (units) (A.Bn.E.Ig.D. and A.Bn.E.Iv.D.), from the position of automated implementation of informational contents of the economic management unitary process, composition, structure, intercon-

nections and interactions of their functional compartments, components and resources are showed in fig. 1

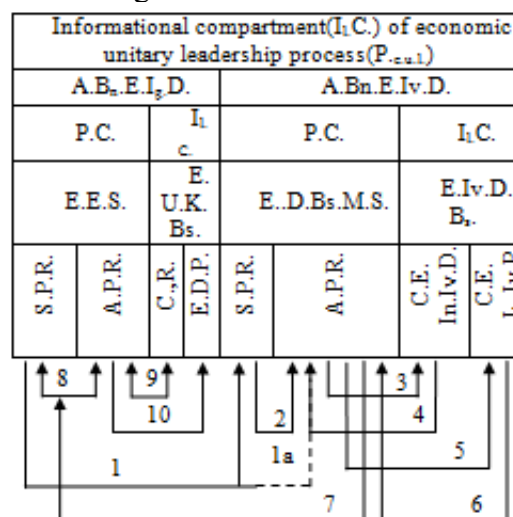
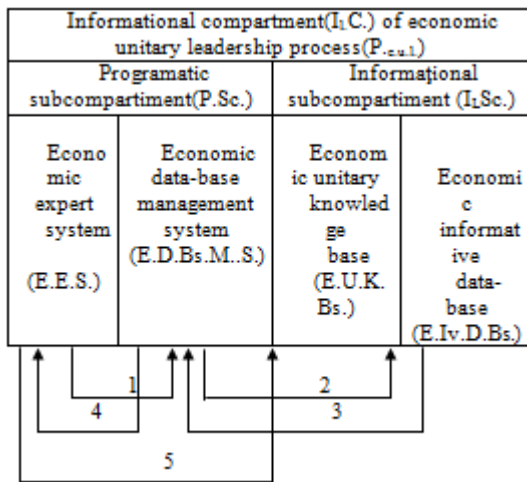

**Fig.1.** The coceptual scheme of the interconnection and interaction of the functional resources of the components and units of economic unitary informatics (automatic) leadership process(P.e.u.l.)

From the scheme showed in fig. 1 it is obvious that the interactions of internal informatics organizational units' resources starts with S.P.R. of E.S. to S.P.R. of D.Bs.M S.(E.S.S.P.R.→E.D.Bs.M.S.S.P.R.(1)). Such an interaction might take place if S.P.R. varies, and if they are unitary, in that case being produced the direct relation :  
 E.S.S.P.R.→ E.D.Bs.M.S.A.P.R. (1a). In the variant when S.P.R. are not the same, after (1) will take place (2) (E.D.Bs.M.S.S.P.R.→E.D.Bs.M.S.A.P.R.),

the last (E.D.Bs.M.S.A.P.R.) will further refer to collections of economic initial informative data (C.E.In.Iv.D.) of E.Iv.D.Bs. (3), then (C.E.Pr.Iv.D.)being read and processed(4) (C.E.Pr.Iv.D. →E.D.Bs.M.S.A.P.R.). This processing results are considered complexes of economic informational informative products (C.E. I<sub>1</sub>I<sub>v</sub>. P.) and are processed in a certain format and volume (5) (E.D.Bs.M.S.A.P.R. → C.E.I<sub>1</sub>I<sub>v</sub>.P.). Further, by A.P.R. of E.D.Bs.M.S. such product complexes are offered to E.S.A.P.R. (C.E.I<sub>1</sub>I<sub>v</sub>.P.→ E.D.Bs.M.S.A.P.R. →E.E.S.A.P.R.) ((6),(7)), which with the help of certain conditions and rules of E.U.K.Bs process them in interaction with E.E.S.S.P.R., therefore obtaining the values of economic decisional products (E.E.S.A.P.R. → E.E.S.S.P.R.; E.E.S.S.P.R. →E.E.S.A.P.R. → E.D.P.) (8),(9),(10)

At the level of functional subcompartments of the economic unitary informatics(automatic) leadership process (P<sub>e.u.l.</sub>) , the entirely interconnections and interactions of their components are showed in fig. 2.



**Fig.2.** The conceptual scheme of interconnections and interactions of components of compartments of the economic unitary informatics (automatic) leadership process (P<sub>e.u.l.</sub>).

According to the scheme form this figure, the constructive architecture of P<sub>e.u.l.</sub> automatically does not include the level of internal informatics organizational units (A.Bn.E.Ig.D. and A.Bn.E.Iv.D.), but consists of two compartments of resources – programmatic

(P.Sc.) and informational (I<sub>1</sub>.Sc.). In its turn, P.Sc. comprises two component categories, the first of them (E.E.S.) manipulating with the informational decision units, and the second (E.D.Bs.M.S.) – with the informational informative units.

Respectively, I<sub>1</sub>.Sc. consists of two categories of informational resources, one of them (E.U.KBs.), being represented by complexes of informational decision units (C.R., E.D.P.), and the other one (E.Iv.D.Bs.) – by complexes of economic primary informative data (C.E.Pr.Iv.D.) and complexes of economic informational informativ products (C.E..I<sub>1</sub>I<sub>v</sub>. .P.).

In such a case, P<sub>e.u.l.</sub> automated working starts with the interaction E.E.S. →E.D.Bs.M.S. (1), then follows E.D.Bs.M.S. → E.Iv.D.Bs. (2), as a result of which C.E.In.Iv.D. on exact application are retrieved, processed, so that afterwards to obtain the required economic informational informativ products (E.I<sub>1</sub>I<sub>v</sub>.P.). Further byE.D.Bs.M.S. (3), E..I<sub>1</sub>I<sub>v</sub>.P. is offeredE. E.S. (4), which by introducing its programmed resources and C.R. of E.K.U.Bs. forms the required decision products (E.D.P.) (5).

For the variant when P<sub>e.u.l.</sub> is developed by a single internal informatics organizational structure (unit) (A.Bn.E.Ig.D.), the automated working scheme of such a process is contained in fig. 3.

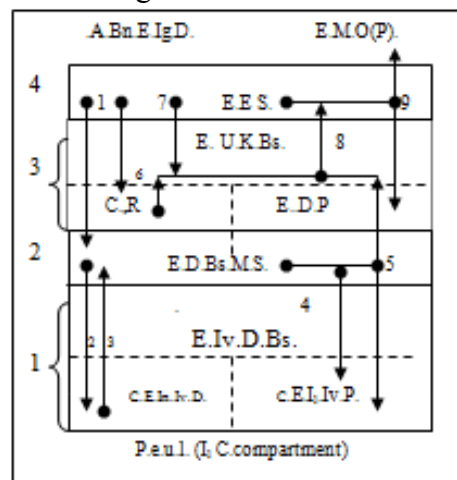

**Fig.3.** The conceptual scheme of the composition, interconnection and interaction of the components of ensure automatic working of P<sub>e.u.l.</sub> in case achievement of the single inter-

nal organizational informatics forme(unite) –  
A.Bn.E.Ig.D.

From fig. 3 it is obvious that at the lowest level (primary level) of A.Bn.E.Ig.D. constructive architecture, E.Iv.D.Bs. components (C.E.In.Iv.D. and C.E.I<sub>l</sub> Iv.P.) are found, from them starting the working banks; at the 2<sup>nd</sup> level –E.D.Bs.M.S., at the 3<sup>rd</sup> level – E.U.K.Bs. components (C.,R. and E.D.P.), and at the highest level – E.E.S.

In such a variant of A.Bn.E.Ig.D. architectural construction, the interconnections and interactions' chain of its components is the following:

- a) first step: E.E.S. → E.D.Bs.M.S. (1); E.D.Bs.M.S. → C.E.In.Iv.D. (E.Iv.D.Bs.) (2);
- b) second step: CE.In.Iv.D. (E.Iv.D.Bs.) → E.D.Bs.M.S. (3); E.D.Bs.M.S. → C.E.I<sub>l</sub>Iv.P. (E.Iv.D.B.) (4);
- c) third step : E.E.S. → C.,R.(E.U.K.Bs.)(6);
- d) fourth step: E.E.S. → E.U.K.Bs.(C.,R and C.E.II.Iv.P.)(7); E.U.K.Bs. (C.,R and C.E.I<sub>l</sub>Iv.P.) → E.E.S.(8);
- e) fifth step: E.E.S. → E.D.P.( E.U.K.Bs.) → E.M. O.(P.)(9).

From the hereinabove succession it can be noticed that within I<sub>l</sub>C. of P<sub>e.u.l.</sub> by A.Bn.E.Ig.D., automated working of the last mentioned (P<sub>e.u.l.</sub>) starts together with E.E.S. referring to E.D.Bs.M.S.(1), for the last to obtain (extract, read) C.E.In.Iv.D. from E.Iv.D.Bs.(2), to process their values(3), and their processing results to be registered in E.Iv.D.Bs.(4). Further, by E.D.B.M.S. → C.E.I<sub>l</sub>Iv.P. → E.U.K.Bs.(5) interactions these complexes of economic informative information products are copied from E.Iv.D.Bs. to E.U.K.Bs.

At the following step E.E.S. refers to (7), copies (8) C.,R. and C.E.I<sub>l</sub>Iv.P. components from E.U.K.Bs., processes them, and ultimately places them for being stored in E.U.K.Bs.(9) and gives them to the economic material object (process) (E.M.O.(P.)) to change its evolution (8) according to value of the E.D.P..

Analytical schemes and formulas to clear up to until now refer to the compositional and functional general aspect of I<sub>l</sub>C. components

of P<sub>e.u.l.</sub>, without taking in consideration the aspect their systemic and essence approach. From systemic positions, both E.U.K.Bs. and E.Iv.D.Bs. architecturally divides in subsystems (SS), sectors (S), complexes of problems (C.P.) and private problems (P) of P<sub>e.u.l.</sub>

Such a division is schematically presented in fig. 4.

On the content positions E.U.K.Bs. of the P<sub>e.u.l.</sub> of E.M.O.(P)) is on the whole built up on economic management positions, which in dependence of their temporal development it is divided into the following large groups:

- 1) positions preceding the material economic activities (M.E.A.), to them referring those of normation (standardization) and regulation (N.R.), of prognostication (PR.), of current planning (C.P.) and operative planning (O.P.);
- 2) positions following M.E.A., to them referring those of primary evidence (P.E.), operative evidence (O.E.), book-keeping (B), statistics (S), operative economic analysis (O.E.A.) and current economic analysis (C.E.A.)

Conceptual structure, interconnections and interactions of the essence aspect of E.U.K.Bs. are schematically presented in fig.5.

Scheme from fig. 5 shows that as an economic information functional essence, E.U.K.Bs. of P<sub>e.u.l.</sub> evolution begins at the same time with the elaboration and putting into working of the normation and regulation (N.R.) subsystem, there from developing the following chain: PR.→C.P.→O.P.→P.E., O.E.→B→S→O.E.A.

→C.E.A.

The displayed succession confirms the combination of all P<sub>e.u.l.</sub> informative activities, economic analyses.

E.U.K.Bs. of the P<sub>e.u.l.</sub>:E.M.S.-economic management systems: E.M.S.S<sub>1</sub>...E.M.S.S<sub>n</sub>-economic management systems; i=1,...,n; E.M.S.E<sub>1</sub>...E.M.S.E<sub>m</sub>-economic management sectors; j = 1,...,m; E.M.P.C<sub>1</sub>...E.M.P.C<sub>q</sub>-economic management problem complexes; l = 1,...,q; E.M.P<sub>1</sub>...E.M.P<sub>k</sub>-economic management

problems;  $s=1, \dots, k$ .

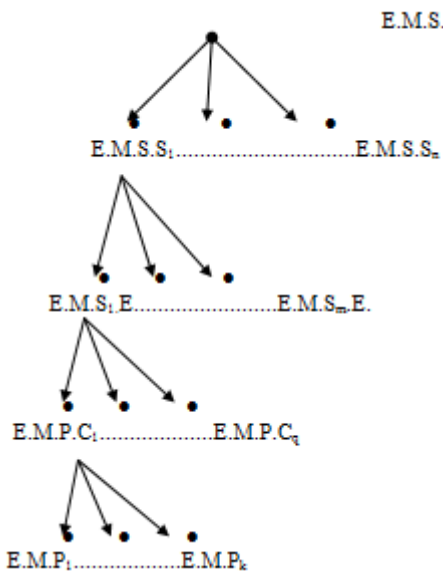

Fig.4. The conceptual scheme of successive decomposition,

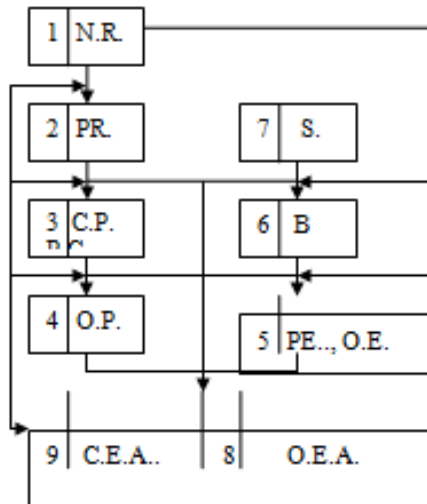

Fig.5. The compositional scheme, interconnections and interactions of economic functional content of the compartments E. U.K.Bs.

Subsystem, after the realization of which inflicts the formulation of economic decisional products (E.D.P.). From the given moment E.A. impact is produced directly on the economic administration system (E.A.S.), resulting with E.D.P. separation from E.I.Iv.P. Therefore, E.A. ends the evolution of E.U.K.Bs. informative subcompartment and serves as a starting point for E.U.KBs. decisional subcompartment development. That is why E.A. has the intermediary position between informative and decisional subcom-

partimnts of the P.<sub>e.u.l.</sub>

Regarding the content interconnections and interactions between E..U.K.Bs. structural informative components, it was established that they are of functional, transformative and pragmatic aspect. Their first category refers to the link-ups and working of informational informative units of each problem, complexe of problems, sector, information (informative and decision) system and subsystem of problems. The second category makes reference to the categories of transformative procedures and operations performed on the reference information units' values, the resulting with the following succession chain: informational procedures (I<sub>1</sub>. .PR.) → structural procedures (S.PR.) → calculus operations (C.O.).

The interconnections and interactions of pragmatic (application) aspect have influence on the implication of economic reference information units in the transformation process of their values and decision formulation. In the context of essence, both transformative and functional, the most frequently produced forms of joint implication of the economic informative informational units are the following: N.R. + PR.; N.R. + C.P.; N.R. + O.P.; N.R. + O.P.; N.R. + B; N.R. + S.; C.P.. + B; C.P + S; O.P..+O.E. etc.

From this panel it can be noticed that the most massive ones are the interconnections and interactions between the reference informational units for normation and regulation of economic material activity (N.R.of E.M.A.), and then of planning (PR, C.P.,O.P.) and partly – of the operative evidence (O.E.), book-keeping (B) and statistical (S.)

The concretization of data semantic (logic) essence is made by its functional predestination (pragmatic aspect). Both this predestination and the essential increase of compositional, volume and complexity, structural variety, have impartially contributed to data specification (ramification) in different varieties.

Further each variety of data has quantitatively and qualitatively developed. These circumstances and motives have brought to the

need of distinguishing and creating certain structural informative units, which allows a more efficient organization of the informational resources.

In this context, the organization of economic data (E.D.) went through a series of evolutionary stages and organizational forms of its operation, the following being the main of them (in evolution order):

- 1) organizational forms based on elementary information units (communications, private; indicators)
- 2) organizational forms based on separate (autonomous) informational massifs;
- 3) organizational forms based on information collections, comprising not only attributes, communications and indicators, but also informational massifs;
- 4) organizational forms based on the principles of informational supports' organization (document cabinet, filing cabinet, roll cabinet, disk cabinet etc.)

For the majority of these forms is characteristic the dispersion of informational units in space and in time, by reason of which they were formed, processed and used separately, unorganized, over and above the systemic, thus interconnected character of the economic reflected informational structures.

But gradually, as the volume and complication level of M.E.A. increases due to mutual relations' strengthening between different subdivisions and economic agents, the need to form and develop an integrated unitary informational nucleus has arisen, which is nothing else but a unitary informational informativ fund (U.I<sub>L</sub>.I<sub>v</sub>.F.) of the economic unit (E.U.).

In such a fund will be stored all the initial informational informative units, which refer to the operated object on the whole and any component of it with the purpose of their further processing, keeping and presentation. This fund also undertakes to render different varieties of derivate data necessary to formulate a definite managerial formula.

This way the main predestination of U.I<sub>L</sub>.I<sub>v</sub>.F. consists in providing data on any process of definite information organization (storing), transformation and utilization.

The fact that the information fund is unitary does not mean that its organization and working is centrally carried out. Even so the processing and utilization of economic information is de facto made in distributive way as the system of economic administration has a lot of temporarily reserved administration levels and administered objects scattered in space.

The need of U.I<sub>L</sub>.I<sub>v</sub>.F. organization is explained and justified by the following main reasons (factors):

- 1) change of the functional area of economic activity environment, meaning that their volume, varieties and efficiency leads to the improvement of their application form and to the creation of a new more innovative administration system. At its turn, the new administration system solicits a new form of organization of the informational resources. As the economic activities need coordination in space and time, they must be carried out according to a unitary concept. Therefore, from the organizational point of view they are being interpreted as a whole in interconnection. As the system of economic activities is realized in form of interconnected unitary organism, the informational resources representing and permanently accompanying them must be also organized as such a unity, which will also assure the connection of informational elements by a unitary concept. Such an organizational and informational unit creation has found its real expression as a unitary informational informative fund (U.I<sub>L</sub>.I<sub>v</sub>.F.);
- 2) this fund establishment contributes to the determination of most rational compositions and adequate structures of the administered object. This is due to the fact that the hereinabove fund organization is inconceivable without the determination of all informational units and connections between them, with their unitary coordination and regulation towards a qualitative and duly data delivery necessary for the decisional activities;
- 3) U.I<sub>L</sub>.I<sub>v</sub>.F. perception as a unitary object leads to the elaboration of an adequate and easy managed data system;
- 4) being the informational model of admi-

nistered object, U.I<sub>1</sub>.Iv.F. guarantees the authenticity, integrity and convenience of the informational system, and hence the quality level increase of informational resources of the business administration system (E.A.S.).

5) the data system organization by U.I<sub>1</sub>.Iv.F. concept also leads to the memory space saving, as in this variant almost any reduplication of informational units and connections between them are being excluded;

6) U.I<sub>1</sub>.Iv.F. unity also contributes to time saving and the decrease of other consumptions related to data recording, storing and alteration, as the indicators of informative units are as a rule printed into the memory just once;

7) the automated organization of informational connections of the economic problems within U.I<sub>1</sub>.Iv.F. contributes to the maximum automatization of data processing processes and information provision for the administration processes. This is explained by the fact that from the informational point of view one problem results from another. Thus the results from one problem solution may be used for the solution of other problems, etc.;

8) U.I<sub>1</sub>.Iv.F. concept application greatly improves the data organization and processing technology turning it into a continuous and automatic process;

9) since U.I<sub>1</sub>.Iv.F. brings all the problems in one unitary complex, this will indirectly contribute to the automation of administration system (informative subcompartment).

Starting with the above enumerated, we can come to the conclusion that U.II.Iv.F. is considered to be an internal unitary information organization form destined for the organization and delivery of any information to the administration system as a whole and any its component.

Initially and for the time being as U.II.Iv.F., are partially organized those informational resources that require permanent storing in informatics memory. Therefore the area of U.II.Iv.F. implementation in the economic informational activity covers just a part of the relatively constant data and this does not include the variable ones, which are daily fixed, organized and processed. That is why

the information varying in volume is enormously wide in comparison with the constant ones.

This affirmation is made to emphasize the level of U.II.Iv.F. theoretical approach and practical implementation, and to confirm that we are now in the initial phase of this activity. Therefore regarding the structure and essence of U.II.Iv.F. of E.U., their functional aspect will be referred to in the economic administration system.

The created situation on U.II.Iv.F. organization and working is also explained by the fact that until now the unitary system of economic data for the economic unit (E.U.) has not been elaborated, the internal and external functional informational relations have not been fully and correctly emphasized.

At the same time even the organization of a part of relatively constant information as U.II.Iv.F. is favorable, as it leads to the reducing of time, memory space and other resources' consumption related to data insertion and processing, as well as of previously enumerated and characterized factors' use.

U.II.Iv.F. elaboration requires the solution of more problems, the main of them being:

1) the determination of problem essence and number, of the collections of problems and informative subsystems, which need to be solved by the economic informatics system, their filtration and distribution on economic administration levels;

2) the selection of U.I<sub>1</sub>.Iv.F. logical structure and of its components. Taking into account that this fund is a totality of data files, appears the problem of selection and determination of a composition and optimal number of data elements, which would offer information to fully satisfy all problems' solution in the economic informatics system (E.Ic.S.) and its subdivisions;

3) the correlation of informational and technological aspect of data automated organization and processing;

4) the elaboration of data base logical structure, which includes such operations like the selection and determination of the totality of data elements contained in the data base structure, the establishment of semantic (log-

ic, essence) relations between them, the emphasize of different types of data structures and correlation between them, the determination of these structures' elements.

During U.II.Iv.F. organization it is also necessary to solve the problem of reduplication of the data values contained in files. In this context, U.II.Iv.F. is considered to be the most economical and rationally built, in which data redundancy is totally excluded, thereby leading to maximal simplification of data files' reading, but at the same time causes difficulties to the elaboration and working processes of E.Ic.S. programmed and technological resources. If in U.II.Iv.F. of the E.U. non-significant redundancy and weak connection is admitted, then a well-set system on files data actualization shall be provided.

.U.II.Iv.F. elaboration process, in virtue of its significance for E.Ic.S. organization, is actually of iterated aspect. This is explained by the fact that according to obtained results within the stage of functional (detail, operational) designing of E.Ic.S. or of experimental exploitation (working) and these results' comparison with the expected ones, in some cases the return (recurrence) to previously fulfilled stages (finished works) is necessary with the view to determine certain materials or to review certain decisions regarding U.II.Iv.F. makeup and structure.

### Conclusions

1) the above description of the make-up, structure and transformative relations of the informative subcompartment elements (units) of E.U.K.B. of A.Bn.E.Ig.D. confirms that even at the conceptual level it presents an extreme complexity, comprising any category of informational resources. But if taking into account the spatial and temporal radius of carried out processes by A.Bn.E.Ig.D., as well as the need of their coordination in these limits, it becomes obvious that the organization and working of E.U.K.B. informative subcompartment is probably one of the most difficult and complex problems of the future modern society. Reasons explaining the created situation in the given field are both of objective and subjective causes, the main be-

ing the inadequate level of classic sciences' evolution (physics, chemistry, biology etc.) and of society as a whole;

2) both the elaboration and working of E.U.K.B. must start from the concept of *P.e.u.l.* full realization, beginning with the material compartment (*C.m.*) and ending with the materialization of taken decisions by *C.il.* and executed by *C.m.*

3) systemic approach of *P.e.u.l.* brings *A.Bn.E.Ig.D.* interpretation as an material – informational unitary nucleus. In such a situation, due to economical process manysidedness and a result of administration cardinal specific of each category of the said processes, *A.Bn.E.Ig.D.* may contain several types of *S.P.R.* and *E.S.*;

4) the extremely complex character, the rather varied constituents' composition, the excessive variety of interconnections and interactions between them within E..U.K.Bs. requires the emphasizing, elaboration and realization of the multitude of interfaces of a rather specific nature;

5) the spatial and temporal radius of E.U.K.Bs. working also create and will create major difficulties regarding its formation, as it's of social aspect, referring to society, its subdivisions and to each separate individual;

6) all the above-mentioned do confirm that at the given moment and in foreseeable perspective the full creation of integrated E..U.K.Bs. presents a practically unworkable problem. But the concept of this basis, as well as its systemic approach with the embracement of all possible components should be taken into account;

7) such an interpretation is justified by the strong dynamics of information science and application. Even though the contribution factors for full E.U.K.Bs. realization lack now, the elucidated concept shouldn't be avoided, as this way the society will be more prepared for the unexpected transition situation to the environment and principles of informational society working and its components. Beside this the necessary expenses for such a transition will be minimal.

8) at the moment one of the most innovative and rational organization forms of E.U.K.Bs.

informative components is considered to be the informational informative fund of the economic unit (U.I. Iv.F.E.U.)

### References

[1] Tudor Șt. Leahu The evolution, specific and problems of constitution and functioning of automatized banks of intelligent Economic data (A.Bn.Ig.E.D.).

Academy of Economic Studies. Faculty of economic cybernetics, statistics and informatics.

Departament of informatics in economy.

Information and knowledge age.

The proceedings of the seventh international conference on informatics in economy, may 2005. Editura economică. INFOREC Printing House, pp.845-851

[2] Tudor Șt. Leahu The functional – conceptual aspect of the composition, structure

and working relations of the composition, structure and working relations of the automatized banks of intelligent economic data (A.Bn.Ig.E.D.)

Volume X, 2006. The 2<sup>nd</sup> supplement of the review “Informatica economică”.

International Conference “Knowledge management.

Projects, systems and technologies”. Bucharest, november, 9-10, 2006. Volume II Reinforcement and extension of universities and business community partnerships in the knowledge era, pp.89 – 96.

Review published by Economic Informatics Department and INFOREC Association with the support of Romanian Ministry of Education and Research. Review accredited by CNCSIS with B-level.