

## PRESSURE DISTRIBUTION ON SPINNING SPINNERETS

by

**Li ZHANG<sup>a,b</sup>, Zhanping YANG<sup>b</sup>, Rouxi CHEN<sup>a</sup>, Ji-Huan HE<sup>a\*</sup>, Jian-Hua CAO<sup>b</sup>,  
Minfeng SONG<sup>b</sup>, and Jie ZHANG<sup>b</sup>**

<sup>a</sup> National Engineering Laboratory for Modern Silk, College of Textile and Engineering,  
Soochow University, Suzhou, China

<sup>b</sup> Nantong Cellulose Fibers Co., Ltd, Nantong, China

Short paper  
DOI: 10.2298/TSCI1305533Z

*A two-dimensional model is used to study the pressure distribution in a chamber of a spinneret system. Darcy's law is adopted for determining the inlet and outlet velocities of the flow. The pressure distribution on the spinneret plate is obtained, and the dead zone, where no nozzle exists, can be optimally determined.*

Key words: spinneret, analytic solution, Darcy's law, pressure distribution

### Introduction

A spinneret is an important part for spinning textile filaments, including nanofibers [1] and hollow fibers [2]. The optimal spinneret design for substantially increasing the spinning velocity has been caught much attention. Wang *et al.* suggested a novel spinneret design for needless electrospinning [3], and other researchers found that the spinneret greatly affects spinning conditions and morphological properties [4, 5].

This paper studies a spinneret system (fig. 1), comprising filter fabrics at the top and a spinneret plate attached to the lower face, where a chamber is formed to supply a spinning solution, and the spinneret plate has nozzle openings in an annular region as illustrated in fig. 1. The solution comes first through the several layers of filtering elements, which can filter the solution progressively to retain impurities of increasing fineness, divide the flow into partial streams, and adjust the pressure distribution on the spinneret plate, and immediately thereafter the solution is extruded through the spinneret orifices to spin various textile filaments.

In this paper we will study the main parameters of the chamber affecting the spinning process.

### Theory

Assume that the flow in the chamber is viscous and incompressible. The mass equation and the momentum equations are:

$$\frac{\partial}{\partial z}(ur) + \frac{\partial}{\partial r}(vr) = 0 \quad (1)$$

$$u \frac{\partial u}{\partial z} + v \frac{\partial u}{\partial r} = -\frac{1}{\rho} \frac{\partial p}{\partial z} + \frac{\mu}{\rho} \left( \frac{\partial^2 u}{\partial z^2} + \frac{\partial^2 u}{\partial r^2} + \frac{1}{r} \frac{\partial u}{\partial r} \right) \quad (2)$$

\* Corresponding author; e-mail: zhangli@necinfo.com

$$u \frac{\partial v}{\partial z} + v \frac{\partial v}{\partial r} = -\frac{1}{\rho} \frac{\partial p}{\partial r} + \frac{\mu}{\rho} \left( \frac{\partial^2 v}{\partial z^2} + \frac{\partial^2 v}{\partial r^2} + \frac{1}{r} \frac{\partial v}{\partial r} - \frac{v}{r^2} \right) \quad (3)$$

where  $u$  and  $v$  are the axial and radial velocity components, respectively,  $p$  is the pressure,  $\mu$  – the viscosity, and  $\rho$  – the density.

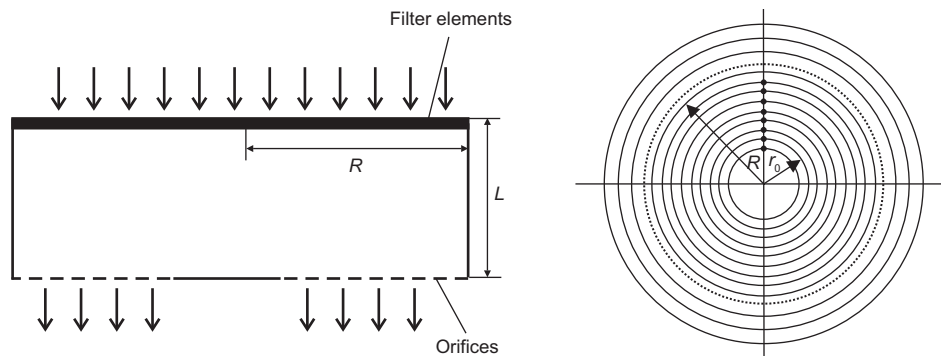

Figure 1. The chamber

Considering the dead zone of the spinneret plate at  $r \leq r_0$ , where no orifice exists, we assume the axial velocity in the chamber can be approximately expressed as:

$$u = \begin{cases} u_0 \left( 1 - \frac{z}{L} \right), & r \leq r_0 \\ u_0 + \frac{u_L - u_0}{L} z, & r > r_0 \end{cases} \quad (4)$$

where  $L$  is the height of the chamber,  $u_0$  – the axial velocity through the filter elements, and  $u_L$  – the spinning velocity at spinnerets.

Using Darcy's law, we have:

$$u_0 = k_0 (p_0 - p|_{z=0}) \quad (5)$$

$$u_L = k_L (p|_{z=L} - p_{\text{out}}) \approx k_L p|_{z=L} \quad (6)$$

where  $k_0$  and  $k_L$  are constants,  $p_0$  – the pressure at entrance before the filter, and  $p_{\text{out}}$  – the pressure at exit.

Using eq. (1) we can calculate the radial velocity:

$$v = \frac{u_0 r}{2L} + \frac{C}{r}, \quad r \leq r_0 \quad (7)$$

$$v = -\frac{u_L - u_0}{2L} r + \frac{D}{r}, \quad r_0 < r \leq R \quad (8)$$

where  $C$  and  $D$  are constants.

Using the boundary condition,  $v = 0$ , at  $r = R$ , the constant,  $D$ , in eq. (8) can be determined. Therefore the radial velocity at  $r_0 < r \leq R$  can be obtained:

$$v = \frac{u_L - u_0}{2Lr} (R^2 - r^2) \quad (9)$$

The continuity of  $v$  at  $r = r_0$  requires:

$$\frac{u_0 r_0}{2L} + \frac{C}{r_0} = \frac{u_L - u_0}{2Lr_0} (R^2 - r_0^2) \quad (10)$$

where from the constant,  $C$ , can be solved:

$$C = \frac{u_L - u_0}{2L} (R^2 - r_0^2) - \frac{u_0 r_0^2}{2L} \quad (11)$$

The radical velocity is, therefore, determined:

$$v = \begin{cases} \frac{u_0 r}{2L} + \frac{C}{r}, & r \leq r_0 \\ \frac{u_L - u_0}{2Lr} (R^2 - r^2), & r_0 < r \leq R \end{cases} \quad (12)$$

where  $C$  is given in eq. (11).

From eqs. (2) and (3),  $p$  can be calculated when  $r \leq r_0$ :

$$p = -\frac{1}{2} \rho u^2 + A\rho = -\frac{1}{2} \rho u_0^2 \left(1 - \frac{z}{L}\right)^2 + A\rho \quad (13)$$

$$p = \mu \left( \frac{\partial v}{\partial r} + \frac{v}{r} \right) - \frac{1}{2} \rho v^2 + B\rho = \mu \left( \frac{u_0}{2L} + \frac{u_0}{2L} \right) - \frac{1}{2} \rho \left[ \frac{u_0 r}{2L} + \frac{C}{r} \right]^2 + B\rho \quad (14)$$

where  $A$  and  $B$  are integral constants to be further determined.

The maximal pressure occurs at:

$$\frac{\partial p}{\partial r} = 0 \quad (15)$$

or

$$\frac{u_0}{2L} - \frac{C}{r^2} = 0 \quad (16)$$

Solving  $r$  from eq. (16):

$$\bar{r} = \sqrt{\frac{2LC}{u_0}} = \sqrt{\frac{(u_L - u_0)(R^2 - r_0^2) - u_0 r_0^2}{u_0}} \quad (17)$$

We set:

$$\bar{r} = r_0 \quad (18)$$

so that the pressure of the spinnerets at  $r = r_0$  is high enough for spinning.

Equation (18) implies that:

$$2u_0r_0^2 = (u_L - u_0)(R^2 - r_0^2) = (u_L - u_0)R^2 - (u_L - u_0)r_0^2 \quad (19)$$

or

$$r_0 = R \sqrt{\frac{u_L - u_0}{u_L + u_0}} \quad (20)$$

Similarly for  $r_0 < r \leq R$ , from eqs. (2) and (3), we have:

$$p = -\frac{1}{2}\rho u^2 + \rho \bar{A} = \rho \bar{A} - \frac{1}{2}\rho \left( u_0 + \frac{u_L - u_0}{L} z \right)^2 \quad (21)$$

$$p = \mu \left( \frac{\partial v}{\partial r} + \frac{v}{r} \right) - \frac{1}{2}\rho v^2 + \bar{B}\rho = \mu \frac{u_L - u_0}{L} - \frac{1}{2}\rho \left[ \frac{u_L - u_0}{2Lr} (R^2 - r^2) \right]^2 + \bar{B}\rho \quad (22)$$

where  $\bar{A}$  and  $\bar{B}$  are integral constants.

Comparing eq. (13) with eq. (22),  $B$  and  $\bar{B}$  can be determined, and finally the pressure distribution can be obtained:

$$p = \mu \frac{u_L - u_0}{L} - \frac{1}{2}\rho \left[ \frac{u_L - u_0}{2Lr} (R^2 - r^2) \right]^2 - \frac{1}{2}\rho \left( u_0 + \frac{u_L - u_0}{L} z \right)^2 \quad (23)$$

The pressure distribution of spinnerets can be obtained by setting  $z = L$ :

$$p|_{z=L} = \mu \frac{u_L - u_0}{L} - \frac{1}{2}\rho \left[ \frac{u_L - u_0}{2Lr} (R^2 - r^2) \right]^2 - \frac{1}{2}\rho u_L^2 \quad (24)$$

where  $u_0$  and  $u_L$ .

The pressure acting on each orifice on the spinneret plate should be larger than the threshold value that is required for spinning. From eqs. (5) and (6), we have:

$$u_0(r) = k_0 \left\{ p_0 - \mu \frac{u_L - u_0}{L} + \frac{1}{2}\rho \left[ \frac{u_L - u_0}{2Lr} (R^2 - r^2) \right]^2 + \frac{1}{2}\rho u_0^2 \right\} \quad (25)$$

$$u_L(r) = k_L \left\{ \mu \frac{u_L - u_0}{L} - \frac{1}{2}\rho \left[ \frac{u_L - u_0}{2Lr} (R^2 - r^2) \right]^2 - \frac{1}{2}\rho u_L^2 \right\} \quad (26)$$

Solving eqs. (25) and (26) simultaneously, the spinning velocity,  $u_L$ , can be determined.

## Conclusions

The paper outlines pressure distribution on the spinneret plate, eq. (24), and the velocity profile on each orifice. Additionally the dead zone in the spinneret plate can be optimally determined.

### Acknowledgment

The work is supported by Priority Academic Program Development of Jiangsu Higher Education Institutions (PAPD), National Natural Science Foundation of China under grant No. 61303236 and No.11372205 and Project for Six Kinds of Top Talents in Jiangsu Province under grant No. ZBZZ-035, Science & Technology Pillar Program of Jiangsu Province under grant No. BE2013072.

### References

- [1] He, J.-H., *et al.*, Review of Fiber Morphology Obtained by Bubble Electrospinning and Blown Bubble Spinning, *Thermal Science*, 16 (2012), 5, pp. 1263-1279
- [2] Radjabian, M., *et al.*, Hollow Fiber Spinning of Block Copolymers: Influence of Spinning Conditions on Morphological Properties, *Polymer*, 54 (2013), 7, pp. 1803-1812
- [3] Wang, X., *et al.*, Electric Field Analysis of Spinneret Design for Needleless Electrospinning of Nanofibers, *Journal of Materials Research*, 27 (2012), 23, pp. 3013-3019
- [4] Serkov, A. T., Afanaseva, Y. V., Flow of Spinning Solution through Spinneret Openings and Deformation Resonance, *Fibre Chemistry*, 31 (1999), 3, pp. 192-196
- [5] Shilton, S. J., Flow Profile Induced in Spinneret during Hollow Fiber Membrane Spinning, *Journal of Applied Polymer Science*, 65 (1997), 7, pp. 1359-1362