

THE MEASUREMENT OF TRITIUM IN WATER SAMPLES WITH ELECTROLYTIC ENRICHMENT USING LIQUID SCINTILLATION COUNTER

by

**Marija M. JANKOVIĆ^{1*}, Dragana J. TODOROVIĆ¹,
Zita KELEMAN², and Nada R. MILJEVIĆ³**

¹Radiation and Environmental Protection Department, Vinča Institute of Nuclear Sciences, University of Belgrade, Belgrade, Serbia

²Soja Protein Laboratory, Bečej, Serbia

³Jaroslav Černi Institute for the Development of Water Resources, Belgrade, Serbia

Scientific paper

DOI: 10.2298/NTRP/1203239J

Tritium (³H) present in the environment decreased in the last decades and nowadays it has low activity concentrations. Measurement of low-level tritium activities in natural waters, *e.g.* in precipitation, groundwater, and river water requires special techniques for water pre-treatment and detection of low-level radioactivity. In order to increase the tritium concentration to an easily measurable level, electrolytic enrichment must be applied. This paper presents the enrichment method performed by electrolysis in a battery of 18 cells, giving an enrichment factor of 5.84 (calculated from 59 electrolyses). The calculated mean values of the separation factor and enrichment parameter were 4.10 and 0.84, respectively. Results for tritium activity in precipitation and surface water collected in Belgrade during 2008 and 2009 are presented.

The Radiation and Environmental Protection Department of the Vinča Institute of Nuclear Sciences, participated in the IAEA TRIC2008 international intercomparison exercise. The participation in the intercomparisons for any laboratory doing low-level ³H measurements in the waters is very important and useful. It is considered the best way to check the entire procedure and methods of the measurements and the reliability of the standard used. The analysis of the reported ³H activity results showed that all results for five intercomparison samples, for which electrolytic enrichment were applied prior to the ³H measurement, are acceptable.

Key words: tritium, water samples, electrolytic enrichment, intercomparison

INTRODUCTION

Tritium (³H) actually present in the environment can be both naturally and artificially produced. Natural tritium is formed in the upper atmosphere by interactions of cosmic radiation with atmospheric gaseous components: $^{14}\text{N} + n \rightarrow ^{12}\text{C} + ^3\text{H}$. Its half-life is (12.33 ± 0.02) year [1, 2]. Anthropogenic tritium is now mainly produced in nuclear power plants when reprocessing nuclear fuel and it can be discharged in the environment mostly in the form of tritiated water.

For many years after contamination, the tritium concentration in natural waters was measurable using a low-level background liquid scintillation counter without any tritium enrichment. Nowadays tritium concentration in rainwater, groundwater, and river water decreased to <20 Tritium Units TU (1 TU = 1 atom

of tritium per 10¹⁸ atoms of hydrogen = 0.11919 ± 0.00021 Bq/kg of water [3]). The mean tritium concentration in precipitation and surface water in the northern hemisphere ranges from 5 TU (0.6 Bq/L) to 10 TU (1.19 Bq/L). At such levels, reliable measurement of tritium without the enrichment of the samples is difficult even using the best performing low-level liquid scintillation detectors [4]. For ³H, it is extremely difficult to determine the absolute specific activities. Tritium activities, are therefore related to a reference water sample which is measured under equal conditions. For this purpose the IAEA and NIST (the former NBS) has a tritium standard NBS-SRM 4361 of 11100 TU available as of September 3, 1978 [5]. After being related to this standard, ³H concentrations are reported in absolute values, corrected for decay to the date of sample collection.

Environmental monitoring of tritium began in a systematic way in 1976, in the Radiation and Environ-

* Corresponding author; e-mail: marijam@vinca.rs

mental Protection Department of the Vinča Institute of Nuclear Sciences, with sampling and measurements of precipitation and surface waters. The tritium activity on all water samples is determined by liquid scintillation counter. In our laboratory, 10-12 electrolyses (each electrolysis containing 16 samples of unknown activity), is done over the year. The regular monitoring covers precipitation collected at the Meteorological station (MS) Usek (2 km from the Vinča Institute in the direction of wind towards the city (Belgrade), MS Zeleno Brdo, and MS in the Vinča Institute; river water from the Danube (Belgrade), the Sava (Belgrade), the Mlaka creek (Vinča Institute), and precipitation, surface and groundwater from the Velika Morava catchment.

Given the fact that nowadays concentrations of tritium in natural waters are near the detection limit, aim of this paper is to point out the necessity of electrolytic enrichment of water samples before measurement. Also, the paper presents the results of our laboratory which participated in the IAEA TRIC2008 international intercomparison, together with many laboratories around the world, where the concentration of tritium was determined by liquid scintillation detector also after enrichment.

MATERIALS AND METHODS

Electrolysis

The sample under investigation is necessary previously distillate to separate potentially present contaminants in water to prevent a proper liquid scintillation performance. The requirement is that no isotopic change occurs during this treatment. Therefore, the distillation procedure has to be as quantitative as possible, *i. e.* a yield close to 90%. A balloon of 1 L is used for distillation, Liebig condenser and the receiving vessel for the distillate. 300-350 mL of sample is weighed and the entire amount of liquid is distilled.

Receiving vessel is well closed to prevent exchange of tritium with water vapor from the air. In order to increase the tritium concentration to an easily measurable level, electrolytic enrichment must be applied [6]. The enrichment process was conducted in an apparatus containing electrolytic cells with co-axial stainless steel electrodes, fig. 1. Electrolytic enrichment of tritium can be performed in three types of cell: (a) in batch cells, the entire sample is added at the beginning of electrolysis, and current is passed until the desired final volume is reached; the electrolyte concentration steadily increases, (b) in periodic addition cells, the enrichment proceeds in a stepwise fashion with additional sample water added periodically as the enriched sample reaches a pre-selected volume, and (c) in continuous feed cells, the loss of water by electrolytic dissociation is fully or partially compensated by continuous addition of sample water from an external reservoir. In both periodic and continuous feed cells, the final stage of the enrichment is a batch process [7]. An enrichment cell must remain electrochemically stable, this means that the only reaction occurring is the electrolytic dissociation of water, with no tendency for other reactions to occur which would corrode the electrode materials or impair the separation of hydrogen isotopes at the cathode. Care must be taken to minimize exposure of the sample during processing to avoid contamination by exchange with atmospheric water vapor. It was generally accepted that batch cells could be operated only within a narrow range of electrolyte concentration, volume reduction by a factor 10-20 was accepted as a workable range for the avoidance of electrode corrosion. Periodic addition and continuous feed cells were developed as a means to achieve higher enrichment in a single cell (consisting of the outer stainless steel anode and a central mild steel cathode), but they have some inherent disadvantages. Firstly, the efficiency of enrichment is not as good as that of a batch cell for an equivalent volume reduction, secondly, they involve greater complexity (continuous feed), or require longer electrolysis peri-

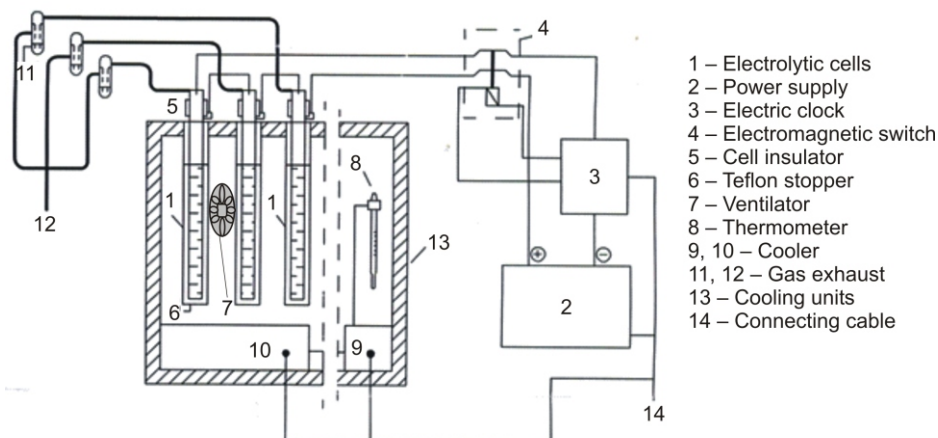

Figure 1. Apparatus for the electrolytic enrichment of tritium in water

ods and more operator attention (periodic addition). Thus it would be advantageous if a batch cell could be developed which would match the volume reduction capability of the other cell types [7].

In each batch cell (schematic diagram of electrolysis cell is given in fig. 2 [8]), a 250 ml portions of previously distilled water (pre-distillation of all samples must be undertaken to eliminate dissolved impurities which may cause corrosion of cell electrodes) with 1 g of Na_2O_2 (an electrolyte which forms NaOH in water and yields an alkaline medium favorable to electric conduction and hence to the reaction of water electrolysis) was electrolyzed. During the dissolution the Na_2O_2 reacts with water according to the following eq.



Current passed through the series of cells decomposes the water to hydrogen and oxygen. Protium is discharged in preference to the heavier isotopes, deuterium and tritium. Therefore, the latter are concentrated in the liquid remaining in the cells. Electrolysis run comprised of 2 reference dilutions of tritiated water and the rest are the samples. Electrolysis was carried out at a current of 5A (voltage of 48 V across each cell) until the volume of electrolyte was reduced

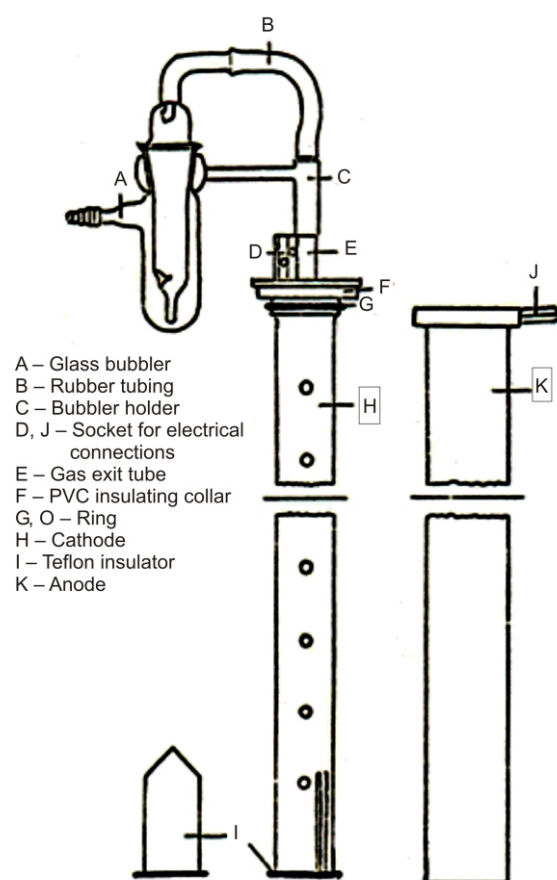

Figure 2. Schematic diagram of electrolysis cell

to 25-30 ml containing about 80% of the original tritium [9]. The duration of electrolysis at 600 Ah was five days. All runs were carried out at temperature 2-5 °C to prevent a loss of tritiated water molecules by evaporation. After electrolysis the samples are distilled to separate the water from the electrolyte. An aliquot of 8 ml from the second 10 ml fraction of the distillate is placed in a 20 ml polyethylene scintillation vial, and mixed with 12 ml of Ultima Gold LLT scintillation cocktail from Perkin Elmer. The tritium activity of water samples is measured by ultra-low-level liquid scintillation spectrometer (LSS). The method is based on the principle that certain materials emit light after their molecules have been excited by collisions with high-energy particles.

Enrichment factor, separation factor and enrichment parameter

Spiked water of known tritium activity concentration (reference dilutions of tritiated water) is used to determine the enrichment factor. If N_{SW} denote tritium concentration (final) of spiked water after enrichment, N_{BE} denote tritium concentration (initial) before enrichment, N_{DW} denote impulses originating from tritium-free (dead) water (the measurement of the background noise is very important when counting samples of low activity and with each set of samples a counting blank is included, prepared from tritium-free water and scintillation solution), the enrichment factor (Z_{IS}) is then defined as [10-12]

$$Z_{\text{IS}} = \frac{N_{\text{SW}}}{N_{\text{BE}}} \frac{N_{\text{DW}}}{N_{\text{DW}}} \frac{V_i}{V_f} \frac{\beta}{1} \quad (2)$$

where V_i is the initial volume of the sample, V_f – the final volume, and β – the separation factor. By transforming eq. 2, we obtain an expression to calculate β from N_{SW} , N_{BE} , N_{DW} , V_i , and V_f

$$\beta = \frac{\ln \frac{V_i}{V_f}}{\ln \frac{N_{\text{SW}}}{N_{\text{BE}}} \frac{N_{\text{DW}}}{N_{\text{DW}}}} \quad (3)$$

Separation factor is an important parameter for evaluating the efficiency of tritium enrichment process. It depends on various factors such as the electrode material, the type of electrolytic cell, the current density and the temperature of the electrolytic cell. The value of separation factor is impossible to predict theoretically. The value $\log \beta \log \alpha = 1.4$ (theoretically deduced by Bigeleisen [13] for the electrolysis of water), where α is separation factor for deuterium, can be used with the predictable limits of 5% variation. Ostlund and Werner [14] experimentally found a value of 1.369 for $\log \beta \log \alpha$.

The enrichment parameter, P , is defined by the eq. 4 [12, 15]

$$P = \frac{F (V_i - V_f) \ln Z_{IS}}{Q \ln \frac{V_i}{V_f}} \quad (4)$$

where F is the Faraday constant (2.975 Ah/g) number of ampere-hours necessary for electrolysis of 1 g of water, and Q [Ah] – the number of ampere-hours for the given enrichment run. V_i , V_f , and Z_{IS} have the same meaning as in the previous equations. In absence of evaporation the factor $F(V_i - V_f)/Q$ is equal to one. Because of certain evaporation during electrolysis this factor is lower than one.

Calculation of tritium activity

The tritium activity of water samples was determined by ultra-low-level liquid scintillation spectrometer LKB-Wallac 1219 RackBeta. The window for tritium was set between 59 and 164 channels. The counting time was 1200 s with ~12 repetitions for each sample and the tritium activity was calculated by averaging the results. The following formula is used to calculate the tritium activity concentration in the analyzed sample [12]

$$A_T = \frac{N_{SA} A_{ST}}{N_{ST} Z_1} D \quad (5)$$

where N_{SA} [cpm] is the net count rate of the sample, N_{ST} [cpm] – the net count rate of the standard, A_{ST} – the activity concentration of the standard, Z_1 – the tritium enrichment factor for the given sample, and D – the factor taking into account decay of tritium in the sample.

The minimum detectable activity for samples at 95% confidence level uncertainty is defined as

$$MDA = \frac{4.66}{\varepsilon V} \sqrt{\frac{N_{DW}^2}{t t_{DW}}} \quad (6)$$

where N_{DW} is the detector background gross counts, t [s] – the sample count time, t_{DW} [s] – the detector background count time, ε [%] – the efficiency, and V [L] – the volume of sample (l).

RESULTS AND DISCUSSION

From 59 electrolyses performed in 9 years, during the period 2001-2009 in the Radiation and Environmental Protection Department of the Vinča Institute, calculated mean separation factor β by eq. 3, with different final volume was 4.10. The volume reduction factor, V_i/V_f , was usually in the range of 8 to 12. Thus, by enriching spike waters in a two cells, β of eq. 3 may be established and used to evaluate the enrichment factors Z_{IS} of the other cells of the same run containing unknown samples. Mean enrichment factor calculated by eq. 2 for 59 electrolysis was 5.84 (with minimum value of 4.19 and maximum value of 8.88).

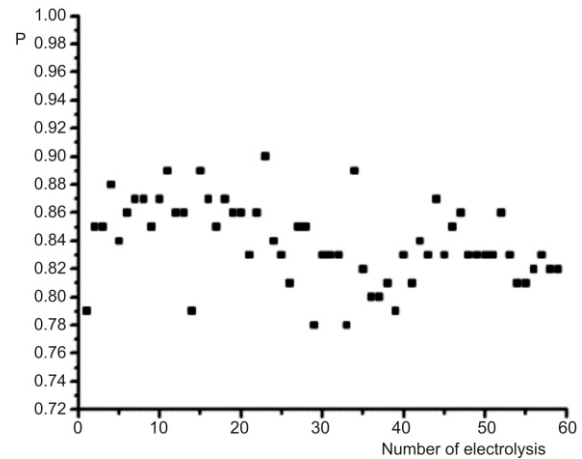

Figure 3. Enrichment parameter as a function of number of electrolysis

Figure 3 presents calculated values for enrichment parameter by eq. 4 as a function of number of electrolysis. Mean value of enrichment parameter was 0.84 which agrees with values obtained in Jožef Stefan Institute in Ljubljana [16].

Normalization of the final volume of the sample

During the electrolysis, except contamination of samples two sources of errors may occur. There is a possible difference in enrichment between different cells and the possible different fractionation of the sample during the distillation [11]. In the enrichment of tritium in water samples using electrolysis, for a series of tests under the same conditions and for the same initial volume, different volumes are obtained after electrolysis (1-5 mL). To eliminate this influence, normalization of the final volume of the sample can be calculated. For the two trials which started electrolysis with the same initial volume, V_i , and ended with a different volume, V_f , we can write

$$N_{f_1} = N_i \frac{V_i}{V_{f_1}} \frac{\beta - 1}{\beta} \quad (7)$$

$$N_{f_2} = N_i \frac{V_i}{V_{f_2}} \frac{\beta - 1}{\beta} \quad (8)$$

$$\frac{N_{f_1}}{N_{f_2}} = \frac{V_{f_2}}{V_{f_1}} \frac{\beta - 1}{\beta} \quad (9)$$

where N_i and N_f are the initial and final tritium concentrations.

If we want to electrolyze samples brought to volume V_f normalize to a certain volume V_s , based on the eq. 9 will be

$$N_c = N_{GSA} \frac{V_f}{V_s} \frac{\beta - 1}{\beta} \quad (10)$$

where N_c is the corrected count rate of the sample, N_{GSA} – the measured count rate of the sample, V_f – the final volume after electrolysis, and V_s – the certain volume to which we want to normalize.

In tab. 1 concrete experimental results are present. In order to calculate corrected count rate, N_c , by eq. 10, separation factor β by eq. 3 must first be determined. Initial volume is always the same, 250 mL, volume at which the normalization is done is 21.8 mL, N_{SW} tritium concentration of spiked water after enrichment was calculated as mean value $(N_{SW1} + N_{SW2})/2$, N_{BE} tritium concentration before enrichment was 269.26 impuls per minute and N_{DW} is 5.51 impuls per minute

$$\beta = \frac{\ln \frac{250}{21.8}}{\ln \frac{250}{22.8} \frac{1743.25}{269.26} \frac{5.51}{5.51}} = 4.4 \quad (11)$$

Calculated corrected count rate is shown in the fourth column of tab. 1.

Loss of tritium

During electrolysis a certain amount of tritium is lost with the hydrogen that is released. Size of this loss is a function of the separation factor. If $N_i V_i$ denotes tritium concentration before electrolysis and $N_f V_f$ denotes tritium concentration after electrolysis, based on eq. 9 we can write

$$\frac{N_f V_f}{N_i V_i} = \frac{V_f}{V_i} \frac{V_i}{V_f} \frac{\beta - 1}{\beta} = \frac{V_f}{V_i} \frac{1}{\beta} \quad (12)$$

For different volume reduction factor, V_f/V_i , and for different separation factor, β , data are shown in tab. 2 [17-19]. When $\beta = 5$ and for volume reduction factor

20, at the end of electrolysis there is only 55% of the initial tritium at the end of electrolysis, whereas when $\beta = 15$, 82% of tritium is concentrated (tab. 2). When $\beta = 1$ it means that there is no electrolytic enrichment and 95% of tritium is lost.

Table 2. Residual activity of tritium in the sample

V_i/V_f	$N_f V_f / N_i V_i$		
	$\beta = 5$	$\beta = 10$	$\beta = 15$
1	1.00	1.00	1.00
5	0.72	0.85	0.90
10	0.63	0.79	0.86
15	0.58	0.76	0.83
20	0.55	0.74	0.82

Tritium activity of the samples

Table 3 presents results for tritium activity for the samples given in tab. 2. Calculated minimum detectable activity for investigated samples was 0.4 Bq/L. Precipitation samples were collected daily at MS Zeleno Brdo (ZB) (44°47' N, 20°32' E, altitude 243.2 m a.s.l.) and in the Vinča Institute (44°47' N, 20°32' E, altitude 95 m a.s.l.). Surface water samples were collected 20-25 times a month in Mlaka creek and the concentration of tritium was measured in the composite monthly sample. Investigation of tritium in the Mlaka creek, which is 5 km long with an average water flow of only 10 L/s, is important because the stream flows within the Vinča Institute, next to the research reactor RA and over Bolečica flows into the Danube. From tab. 3 it can be seen that in samples collected at VINS tritium content appears to be one order of magnitude higher than that of samples from ZB, attributable to the influence of local contamination by heavy water nuclear reactor [9]. Tritium activity obtained for the Mlaka creek samples is higher than the tritium activity obtained for the river

Table 1. Corrected count rate due to the different final volume of samples

Sample	Final volume, V_f [mL]	Measured count rate N_{GSA} [min^{-1}]	Correctede count rate N_c [min^{-1}]	Count rate difference N_{GSA} [min^{-1}]
Zeleno Brdo, November 2008	22	6.42	6.47	-0.05
Zeleno Brdo, December 2008	22.2	5.86	5.94	-0.08
N_{SW1}	23	1631.79	1700.53	-68.74
Zeleno Brdo, January 2009	22.5	5.92	6.07	-0.15
Zeleno Brdo, February 2009	21	5.89	5.72	0.17
Vinča Institute, November 2008	22	7.86	7.92	-0.06
Vinča Institute, December 2008	20.7	9.09	8.73	0.36
Vinča Institute, January 2009	21.3	8.34	8.19	0.15
Vinča Institute, February 2009	23.8	7.33	7.84	-0.51
Mlaka creek, October 2008	22.1	15.81	15.98	-0.17
Mlaka creek, November 2008	20.9	19.45	18.83	0.62
Mlaka creek, December 2008	21	20.15	19.58	1.57
Mlaka creek, January 2008	22.4	19.64	20.05	-0.41
Mlaka creek, February 2008	21	19.71	19.15	0.56
N_{SW2}	21	1854.70	1802.07	52.63

Table 3. Tritium activity in precipitaton and surface water

Precipitation	Tritium activity [BqL ⁻¹]	Surface water	Tritium activity [BqL ⁻¹]
Zeleno Brdo, November 2008	1.93	Mlaka creek, October 2008	19.19
Zeleno Brdo, December 2008	0.43	Mlaka creek, November 2008	25.97
Zeleno Brdo, January 2009	0.87	Mlaka creek, December 2008	27.28
Zeleno Brdo February 2009	0.80	Mlaka creek, January 2009	26.31
Vinča Institute, November 2008	4.97	Mlaka creek, February 2009	26.45
Vinča Institute, December 2008	6.67		
Vinča Institute, January 2009	5.26		
Vinča Institute, February 2009	3.38		

waters of the Sava (mean value for 2008. is 2.75 Bq/L) and Danube (mean value for 2008. is 2.21 Bq/L).

Interlaboratory comparison IAEA TRIC2008

The eighth IAEA interlaboratory comparison on the determination of tritium in water at environmental level (named TRIC2008) was started in December 2008. Six samples had been prepared before hand at IAEA by gravimetric dilution of a high level tritium standard (SRM4927F) with tritium free water. The massic activity of SRM4927F at 1.12.2008. was 356.7 ± 2.3 kBq/g. Since the Radiation and Environmental Protection Department of the Institute Vinča is measuring the natural ³H concentration in the waters for environmental control and hydrology reasons, it was necessary to take part in this intercomparison. Given the fact that the concentration of tritium in the five samples (T14, T15, T16, T17, and T18) obtained by the IAEA is low, electrolytic enrichment described in section *Electrolysis* must be applied. Sample T19 was measured without electrolytic enrichment because of its high level. Samples were measured on ultra low-level liquid scintillation spectrometer Quantulus 1220 (Perkin Elmer) in Soja Protein Laboratory using standard SRM 4926E (NIST). An aliquot of 8 ml from the second 10 ml fraction of the distillate was placed in a 20 ml polyethylene scintillation vial, and mixed with 12 ml of OptiPhase HiSafe 3 scintillation cocktail from Perkin Elmer. Neither glass vials nor teflon-cooper vials were used because of their relatively high background in the tritium window and their high cost for routine monitoring [20]. The counting time was 30 minutes with 33 repetitions for each sample and the tritium activity was calculated by averaging the results. The minimum detectable activity (MDA) achieved was 2.5 TU.

The results of tritium concentrations in six intercomparison samples of low-level tritium measurements in Radiation and Environmental Protection Department of the Vinča Institute and reference values published by the IAEA TRIC2008 [21] are presented in tab. 4.

Table 4. Tritium concentrations intercomparison sample

Sample	IAEA		Vinča Institute	
	A_{IAEA}	Q_{IAEA} [TU]	A_{IAEA}	Q_{IAEA} [TU]
T14	1.54	0.05	1.7	0.4
T15	4.07	0.05	3.9	0.4
T16	7.74	0.06	8.0	0.6
T17	14.46	0.08	14.4	0.8
T18	0.67	0.05	1.5	0.4
T19	568.7	2.3	575.9	30.6

The value of the parameter z -score represents the deviation of the measured values in the Radiation and Environmental Protection Department, Vinča Institute of Nuclear Sciences from the reference IAEA values and it was calculated from the following equation

$$z\text{-score} = \frac{A_{LAB} - A_{IAEA}}{\sigma_{LAB}} \quad (13)$$

where A_{LAB} and σ_{LAB} are activity of the sample and uncertainty of the sample measured in the Radiation and Environmental Protection Department of the Vinča Institute; A_{IAEA} and σ_{IAEA} are activities of sample and uncertainty of the sample published by IAEA. The laboratory performance is evaluated as satisfactory if z -score < 2 , questionable for $2 < z$ -score < 3 , and unsatisfactory for z -score > 3 . Four samples had z -score > 0 (measured values of ³H were higher than reference values) and two samples had z -score < 0 (measured values of ³H were lower than reference values), with a mean value of 0.44.

The value of the parameter u represents an acceptance of measurement results and it was calculated from eq. [22]

$$u = \frac{|A_{LAB} - A_{IAEA}|}{\sqrt{\sigma_{LAB}^2 + \sigma_{IAEA}^2}} \quad (14)$$

If u value is less than 1.64 (IAEA), the results are acceptable and do not deviate from the reference value. For five samples calculated u values are less than 1.64, except for sample T18 ($u = 2.06$) but this result is also acceptable as published in IAEA report.

The Radiation and Environmental Protection Department of the Vinča Institute participated in the fourth intercomparison for low-level tritium counting in waters in 1985 [23], the sixth IAEA intercomparison of

low-level tritium measurements in water in 2000 [24], the seventh IAEA intercomparison exercise of low-level tritium measurements in water – TRIC 2004 – and the analyses of reported tritium activity results showed that all results were acceptable.

CONCLUSIONS

Given the fact that the concentration of tritium in water samples is low (below 20 TU), electrolytic enrichment must be applied in order to increase the tritium concentration to an easily measurable level. Each electrolysis should be stable and in each individual electrolysis parameters such as electrolytic parameter, separation factor and enrichment parameter must be determined. This paper gives the results for these parameters from 59 electrolyses performed over 10 years. Electrolytic enrichment and measuring the activity of tritium in water by liquid scintillation counter provide detection of very low activity and the continued application of isotopes in hydrogeology, ecology and meteorology. In this paper, some results of measurements of tritium in precipitation and surface waters in Belgrade, which were obtained after electrolytic enrichment, are presented.

The Radiation and Environmental Protection Department at the Vinča Institute participated in the IAEA TRIC2008 international intercomparison exercise. The analysis of reported ^3H activity results in terms of z -score and u parameters showed that all results were acceptable.

ACKNOWLEDGEMENT

The paper is a part of the research supported by the Ministry of Education, Science and Technological Development of the Republic of Serbia (Project No. III 43009).

REFERENCES

- [1] Unterweger, M. P., Lucas, L. L., Calibration of the National Institute of Standards and Technology Tritiated-Water Standards, *Applied Radiation and Isotopes*, 52 (2000), 3, pp. 527-531
- [2] Lucas, L. L., Unterweger, M. P., Comprehensive Review and Critical Evaluation of the Half-Life of Tritium, *J. Res. Natl. Inst. Stand. Technol.*, 105 (2000), 4, pp. 541-549
- [3] Plastino, W., *et al.*, Tritium in Water Electrolytic Enrichment and Liquid Scintillation Counting, *Radiat. Measur.*, 42 (2007), 1, pp. 68-73
- [4] Garbarino, G., *et al.*, Development of an Electrolysis System for Tritium Enrichment in Superficial Water Samples, *Radiation Protection Dosimetry*, 137 (2009), 3-4, pp. 329-331
- [5] Unterweger, M. P., *et al.*, Preparation and Calibration of the 1978 National Bureau of Standards Tritiated-Water Standards, *Int. J. Appl. Radiat. Isot.*, 31 (1980), 10, pp. 611-614
- [6] Kaufman, S., Libby, W. F., The Natural Distribution of Tritium, *Phys. Rev.*, 93 (1954), 6, pp. 1337-1344
- [7] Taylor, C. B., Experience with a New Type of Batch Cell and Associated Equipment for the Achievement of Volume Reductions Greater than 100 in the Electrolytic Enrichment of Tritium, Low-Level Tritium Measurement, *Proceedings, Consultants Group Meeting on Low-Level Tritium Measurement Organized by the IAEA*, 24-28 September, Vienna, 1979, pp. 101-132
- [8] Florkowski, T., Payne, B. R., Sauzay, G., Interlaboratory Comparison of Analysis of Tritium in Natural Waters, *Int. J. Appl. Rad. Isot.*, 21 (1970), 8, pp. 453-458
- [9] Janković, M., Todorović, D., Determination of Symmetrical Index for ^3H in Precipitation and ^{137}Cs in Ground Level Air, *Water Air Soil Pollut.*, 223 (2012), 3, pp. 979-987
- [10] Hartley, P. E., Design and Performance of Tritium Measurement Systems Using Electrolytic Enrichment, *Nuclear Instruments and Methods*, 100 (1972), 2, pp. 229-235
- [11] Sauzay, G., Schell, W. R., Analysis of Low Level Tritium Concentrations by Electrolytic Enrichment and Liquid Scintillation Counting, *International Journal of Applied Radiation and Isotopes*, 23 (1972), 1, pp. 25-33
- [12] Rozanski, K., Groning, M., Tritium Assay in Water Samples Using Electrolytic Enrichment and Liquid Scintillation Spectrometry, in: *Quantifying Uncertainty in Nuclear Analytical Measurements*, IAEA-TECDOC-1401, IAEA, Vienna, 2004, pp. 195-217
- [13] Bigeleisen, J., Correlation of Tritium and Deuterium Isotope Effects, *Tritium in Physical and Biological Sciences*, IAEA, Vienna, 1 (1962) pp. 161-168
- [14] Ostlund, H. G., Werner, E., The Electrolytic Enrichment of Tritium and Deuterium for Natural Tritium Measurements, *Tritium in Physical and Biological Sciences*, IAEA, Vienna, 1 (1962) pp. 95-104
- [15] Florkowski, T., Tritium Electrolytic Enrichment Using Metal Cells, Low-Level Tritium Measurement, *Proceedings, Consultants Group Meeting on Low-Level Tritium Measurement Organized by the IAEA*, 24-28 September, Vienna, 1979, pp. 133-138
- [16] Barešić, J., *et al.*, Measurement of Tritium in Water by Liquid Scintillation Counter with Electrolytic Enrichment, *Proceedings, Eighth Symposium of the Croatian Radiation Protection Association* (Eds. I. Krajcar-Bronić, N. Kopjar, M. Milić, G. Branica), 13-15 April, Krk, Croatia, ISBN 978-953-96133-7-0, CRPA Zagreb, 2011, pp. 461-467
- [17] Stojaković, R. D., Enrichment of Tritium in Water by Electrolysis for Measuring its Low Activity (in Serbian), Report, IBK-1392, Vinča Institute of Nuclear Sciences, Belgrade, 1976, pp. 1-23
- [18] Hadžišehović, M., Distribution of Isotopes of Light Elements in Natural Waters and Their Measurement (in Serbian), Ph. D. thesis, Faculty of Natural Science, University of Belgrade, Belgrade, 1978
- [19] Tončev, N., Radioactivity of Tritium in Precipitation and Surface Waters in Serbia, M. Sc. thesis, Department of Chemical and Physicochemical Science, Faculty of Natural Science, University of Belgrade, Belgrade, 1977
- [20] Kaihola, L., Glass Vial Background Reduction in Liquid Scintillation Counting, *The Science of the Total Environment*, 130/131 (1993), pp. 297-304
- [21] Groning, M., *et al.*, Eight IAEA Interlaboratory Comparison on the Determination of Low-Level

- Tritium Activities in Water (TRIC2008), Report IAEA, Vienna, 2009
- [22] Papandreou, M. A. S., *et al.*, Monitoring of ^7Be Atmospheric Activity Concentration Using Short Term Measurements, *Nucl Technol Radiat*, 26 (2011), 2, pp. 101-109
- [23] Šipka, V., *et al.*, Intercomparison of Low-Level Tritium Counting in Water, Radiation Protection Selected Topics, Dubrovnik, Yugoslavia, 1989, pp. 438-442
- [24] Šipka, V., Pavlović, S., Miljević, N., Sixth IAEA Intercomparison of Low-Level Tritium Measurements in Water, *Proceedings*, 22th Yugoslav Radiation Protection Symposium, Petrovac, Serbia and Montenegro, 2003, pp. 141-144

Received on April 5, 2012

Accepted on July 31, 2012

**Марија М. ЈАНКОВИЋ, Драгана Ј. ТОДОРОВИЋ,
Зита КЕЛЕМАН, Нада Р. МИЉЕВИЋ**

**МЕРЕЊЕ ТРИТИЈУМА У УЗОРЦИМА ВОДА НАКОН
ЕЛЕКТРОЛИТИЧКОГ ОБОГАЂЕЊА КОРИШЋЕЊЕМ ТЕЧНОГ
СЦИНТИЛАЦИОНОГ ДЕТЕКТОРА**

Тритијум који је присутан у животној средини, од нуклеарних проба до данас има тенденцију опадања и данас има ниске активности. Мерење ниских активности тритијума у природним водама (падавинама, површинским водама и подземним водама) захтева посебне технике припреме самих узорака и детекцију малих активности. Да би тритијум у узорцима могао да се детектује, потребно је повећати његову концентрацију путем електролитичког обогађења. У овом раду приказани су резултати за 59 електролиза, и добијен је фактор обогађења од 5.84. Средње вредности сепарационог фактора и параметра обогађења биле су 4.10 и 0.84, редом. Приказани су и резултати за концентрацију тритијума у падавинама и површинским водама сакупљеним у Београду током 2008. и 2009. године.

Лабораторија за заштиту од зрачења и заштиту животне средине у Институту "Винча" учествовала је у интеркомпарацији IAEA TRIC2008 за одређивање ниских активности тритијума. Сви добијени резултати за 5 узорака интеркомпарације, за које је примењено електролитичко обогађење, су задовољавајући.

Кључне речи: тритијум, узорци вода, електролитичко обогађење, интеркомпарација