

Reducing Fuel Consumption in Bucharest Terminal Area for Flights Using a Standard Instrument Departure

Alin George DIACONU*^{†1}, Octavian Thor PLETER^{‡1} and Virgil STANCIU^{§1}

*Corresponding author

¹“POLITEHNICA” University of Bucharest, Faculty of Aerospace Engineering,
Spl. Independentei 313, 060042 Bucharest, Romania
alin07_a@yahoo.com, octavianpleter@yahoo.com, vvirgilstanciu@yahoo.com

DOI: 10.13111/2066-8201.2011.3.2.2

Abstract: *Reconfiguration of the standard instrument departure and standard arrival routes at certain airports can bring significant reductions in fuel consumption and level of noise. This can be done either by implementing modern radionavigation aids for terminal areas or by eliminating the flying restrictions over cities and inhabited places and designing of low level of noise procedures for these areas. These solutions have other important benefits like decreasing the workload for the air traffic controllers and reducing the total flight time. The paper describes an operational solution in this manner for Bucharest Henri Coanda International Airport.*

Key Words: *air traffic management, standard instrument departure, flight procedure.*

INTRODUCTION

Standard Instrument Departures are produced with the object of expediting the safe and efficient flow of air traffic operating from the same or different runways at the same or neighbouring airfields. SIDs aim is to deconflict potentially conflicting traffic by the use of specific routings, levels and check points.

Typically, each runway will have a number of SIDs and STARs to ensure that air traffic is not unnecessarily delayed by deviation from the direct route from or to the aerodrome. Although a SID will keep aircraft away from terrain, it is optimized for ATC route of flight and will not always provide the lowest climb gradient, but strike a balance between obstacle avoidance and airspace considerations.

In order to permit all weather operation (low visibility take-off and landing) procedures are established to provide track guidance and terrain avoidance for aircraft departing, and track guidance, terrain clearance and where special equipment is used, vertical displacement guidance for aircraft arriving at aerodromes.

It is implied that any procedure developed will not require aircraft to fly dangerously close to obstacles at any point during the procedure. Clearance from obstacles can be obtained by lateral clearance and vertical clearance.

Obstacle clearance can be provided by assessing the highest obstacle to be flown over and by applying a safety margin to the obstacle height. Departure procedures assume that all engines are operating. The design of an instrument departure procedure is, in general, dictated by the terrain surrounding the aerodrome, but may also be required to cater for ATC requirements (adjacent ATS routes, restricted, danger or prohibit areas).

[†] PhD student in Aerospace Engineering of UPB-FIA

[‡] PhD in Aerospace Engineering and in Economic Sciences, associate professor at UPB-FIA

[§] PhD in Aerospace Engineering, dean of UPB-FIA

Where instrument departures are expected to be used, a departure procedure will be established for each runway to be used, and will define the procedure for the various categories of aircraft based on an engine running procedure design gradient of 3.3% or an increased procedure design gradient if required to achieve minimum obstacle clearance.

The procedures assume that pilots will not compensate for wind effects when being radar vectored, and will compensate for known or estimated wind effects when flying departure routes which are expressed as tracks to be made good. Obstacle clearance is a primary safety consideration in instrument departure procedures. Unless otherwise stated a procedure design gradient (PDG) of 3.3% is assumed. The PDG is made up of 2.5% gradient of obstacle identification surfaces or the gradient based on the most critical obstacle penetrating these surfaces, and 0.8% increasing obstacle clearance. There are two basic types of departure routes, straight, or turning.

Departure routes are based on track guidance acquired within 20Km (10.8NM) from the end of the runway (DER) on straight departures, and within 10Km (5.4NM) after completion of turns on turning departures. The design of the instrument departure routes are based on the definition of tracks to be followed along which the pilot is expected to correct for known wind and to remain within the protected airspace.

Straight departures. A straight departure is one in which the initial departure track is within 15° of the alignment of the runway. Track guidance can be provided by VOR, NDB or RNAV.

Turning departure. If the departure track requires a turn of more than 15°, a turning area is constructed and the turn required is commenced upon reaching a specified altitude/height, at a fix and at a facility (VOR, NDB, etc.). Straight flight is assumed until reaching an altitude of at least 120m (394 ft) above the elevation of the departure end of runway (DER).

Omnidirectional departures. Where no track guidance is provided in the design of a departure procedure, the departure criteria are developed by using the omnidirectional method which basically provides for initial departure tracks to be undefined. In other words, once off the end of the runway and at a safe height, the aircraft can be navigated in any direction required to achieve the initial en-route point.

It may be that some sectors of the departure area may contain obstacles which preclude departures in that direction, in which case the published procedures will be annotated to show the restricted sectors.

The basic procedure is that the aircraft will climb on the extended runway centerline to 120m (394ft) before turns can be specified, and at least 90m (295ft) of obstacle clearance will be provided before turns greater than 15° can be specified.

Where obstacles do not permit the development of omnidirectional procedures, it is necessary to fly a departure route (straight or turning), or ensure that ceiling and visibility will permit obstacles to be avoided by visual means.

DESIGNING A STANDARD INSTRUMENT DEPARTURE OVER BUCHAREST

The following will describe the benefits and design details for a standard instrument departure route from Bucharest Henri Coanda Airport, runway 08 L and 08 R, to ABRUT and POLUN waypoints, which consists of passing the flights over the city in order to reach these exit points from Bucharest Terminal Area, instead of flying the actual procedure which

avoids the prohibit area over the city, extended from ground to FL175, and constrain the aircraft to evade the city through south.

First of all there will be presented a few details and criteria taken into account during the design process of the procedure.

It is computed a turning departure which incorporates a turn of more than 15° with the turn being specified at LARAN which is a fly-by waypoint.

Straight flight it is assumed until reaching a height of at least 120 m (394 ft) above the elevation of the DER (314 ft for Bucharest Henri Coanda Airport, runway 08 L and 08 R) which means 708 ft in this case. The areas considered in the design of this turning departure are defined as:

- a) the turn initiation area; and
- b) the turn area

Turn initiation area. The turn initiation area is an area within which the aircraft conducts a straight climb in order to reach the minimum obstacle clearance required prior to the beginning of a turn 90m (295ft). It is already specified the altitude which should be reached at the turning point (708ft).

For aeroplanes, the turn initiation area starts at a point 600m from the start of runway. From the start of the turn initiation area to the DER, the area is 300m wide. It is centred on the runway centre line and splays at an angle of 15° on each side of the extended runway center line.

The initial departure track may be adjusted by 15° or less. When adjusted, the splay of the area boundary on the side of the track adjustment is increased by the track adjustment angle, starting at the DER.

On the side opposite the track adjustment, the boundary is adjusted by the same amount at a point where the PDG reaches 120m (394ft). This distance is nominally 3.5km/1.9 NM from the DER for a 3.3 per cent PDG.

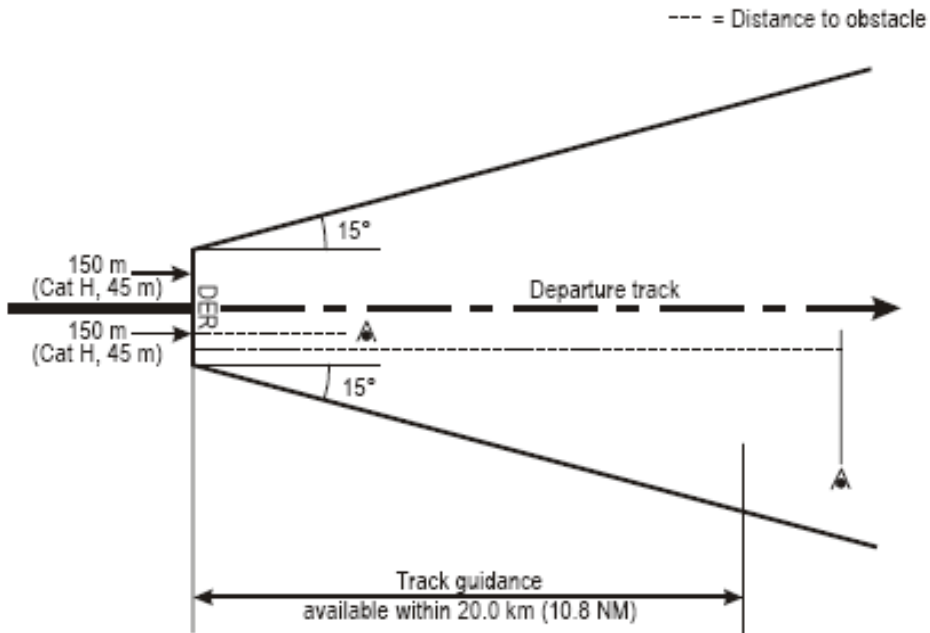

Straight departure area without track guidance

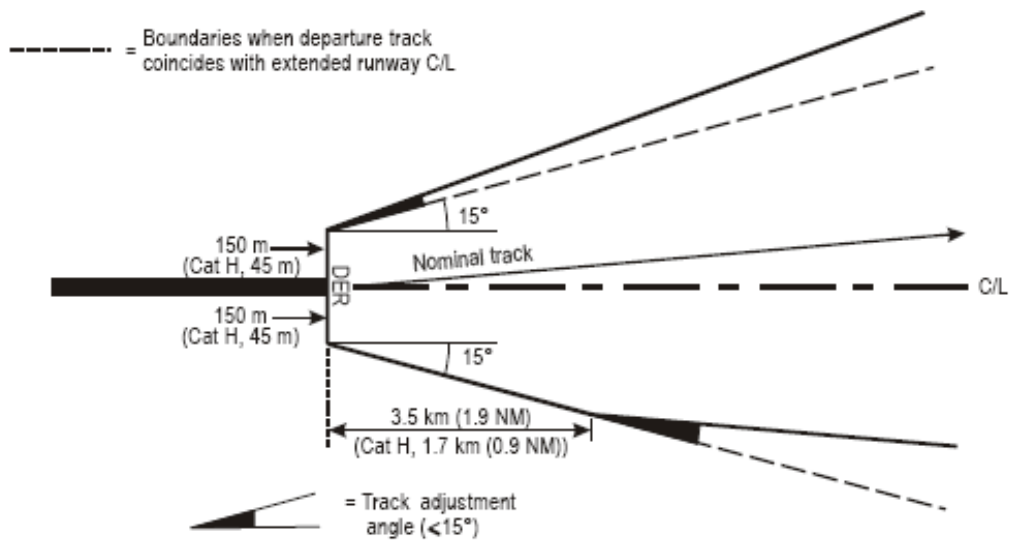

Straight departure area with track adjustment (track adjustment point not specified)

The turn initiation area terminates at the turning point.

The turning point may be defined by:

- a) the earliest fix tolerance of the turning point fix (turn at designated turn point); or
- b) the position at which the PDG reaches the specified turn altitude/height.

The turning point may be located no closer to the DER than the distance required at the PDG to reach the higher of 120 m (394 ft) or the specified turn altitude/height.

Turn area. The turn area is the area in which the aircraft is considered to be turning. The parameters on which turn areas are based are:

- a) altitude:
 - 1) turn designated at an altitude/height: turn altitude/height;
 - 2) turn at a designated turning point: aerodrome elevation plus 10 per cent of the distance from the DER to the turning point
- b) temperature: ISA +15⁰ C corresponding to a) above;
- c) the speed tabulated for “final missed approach” which is 265 kts for the aircraft studied flying this procedure (an MD 11), increased by 10 per cent to account for increased aircraft mass at departure. However, where operationally required to avoid obstacles, reduced speeds not less than 1.1 times the IAS tabulated for “intermediate missed approach” (which is 185 kts) may be used, provided the procedure is annotated “Departure turn limited to ...kts IAS maximum”. In order to verify the operational effect of a speed limitation, the speed should be compared with the statistical speed;
- d) true airspeed: the IAS in c) above adjusted for altitude a) and temperature b);
- e) wind: maximum 95 per cent probability wind on an omnidirectional basis, where statistical wind data are available. Where no wind data are available, an omnidirectional 56 km/h (30 kt) wind should be used;
- f) bank angle: 15° average achieved; for this computation it was used a bank angle of 20° which is permitted between 1000 and 3000ft.
- g) fix tolerance: as appropriate for the type of fix;

- h) flight technical tolerances: a distance equivalent to 6 seconds of flight (3 second pilot reaction and 3 second bank establishing time) at the specified speed; and
 - i) secondary areas: secondary areas are applied where track guidance is available
- The turn area begins at the designated turning point LARAN.

A designated turning point is selected to allow the aircraft to avoid an obstacle straight ahead. The straight departure criteria apply up to the earliest turning point.

Turn point tolerance. The longitudinal limits of the TP tolerance are:

- a) earliest limit, the end of the turn initiation area (K-line); and
- b) latest limit.

Obstacle clearance in the turn area

In order to ensure that the minimum obstacle clearance in the turn area has been provided, we have to use the following equation to check the maximum height of an obstacle in the turn area above the elevation of the DER:

$$\text{Maximum height of obstacle} = PDG(dr + do) + H - MOC$$

where: do = shortest distance from obstacle to line K-K

dr = horizontal distance from DER to line K-K (earliest TP)

PDG = promulgated procedure design gradient

H = OIS height at DER (5 m or 16 ft)

MOC = the greater of $0.008(dr + do)$ and 90 m (295 ft) (Cat H, 80 m (265 ft))

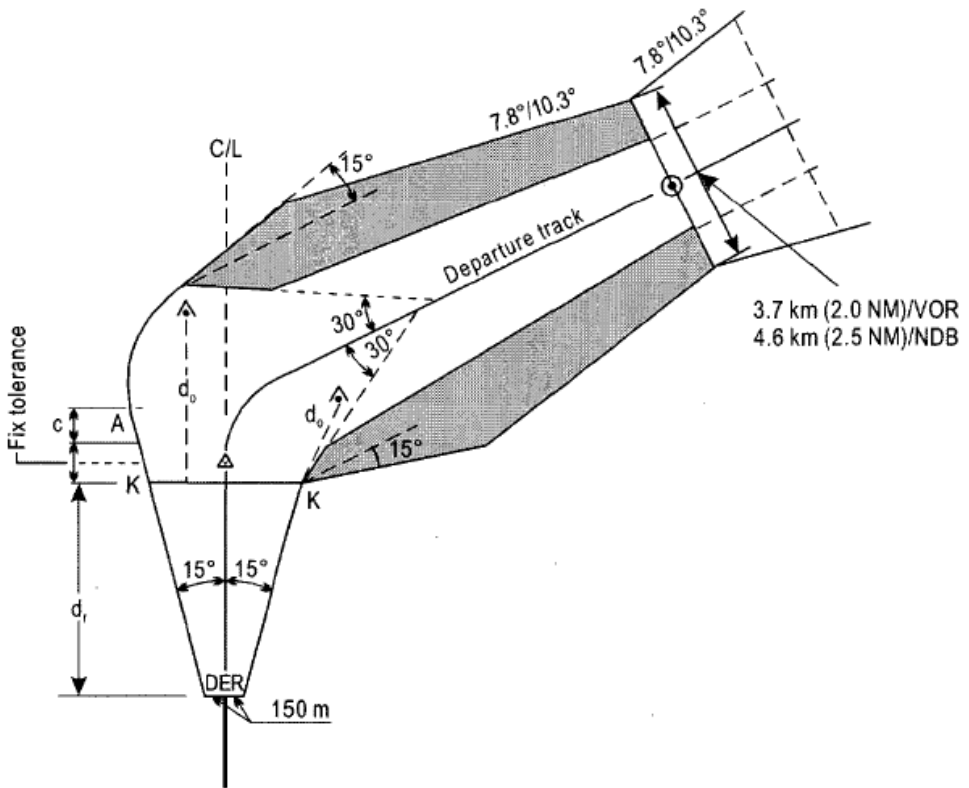

Turning departure – Turn at a fix

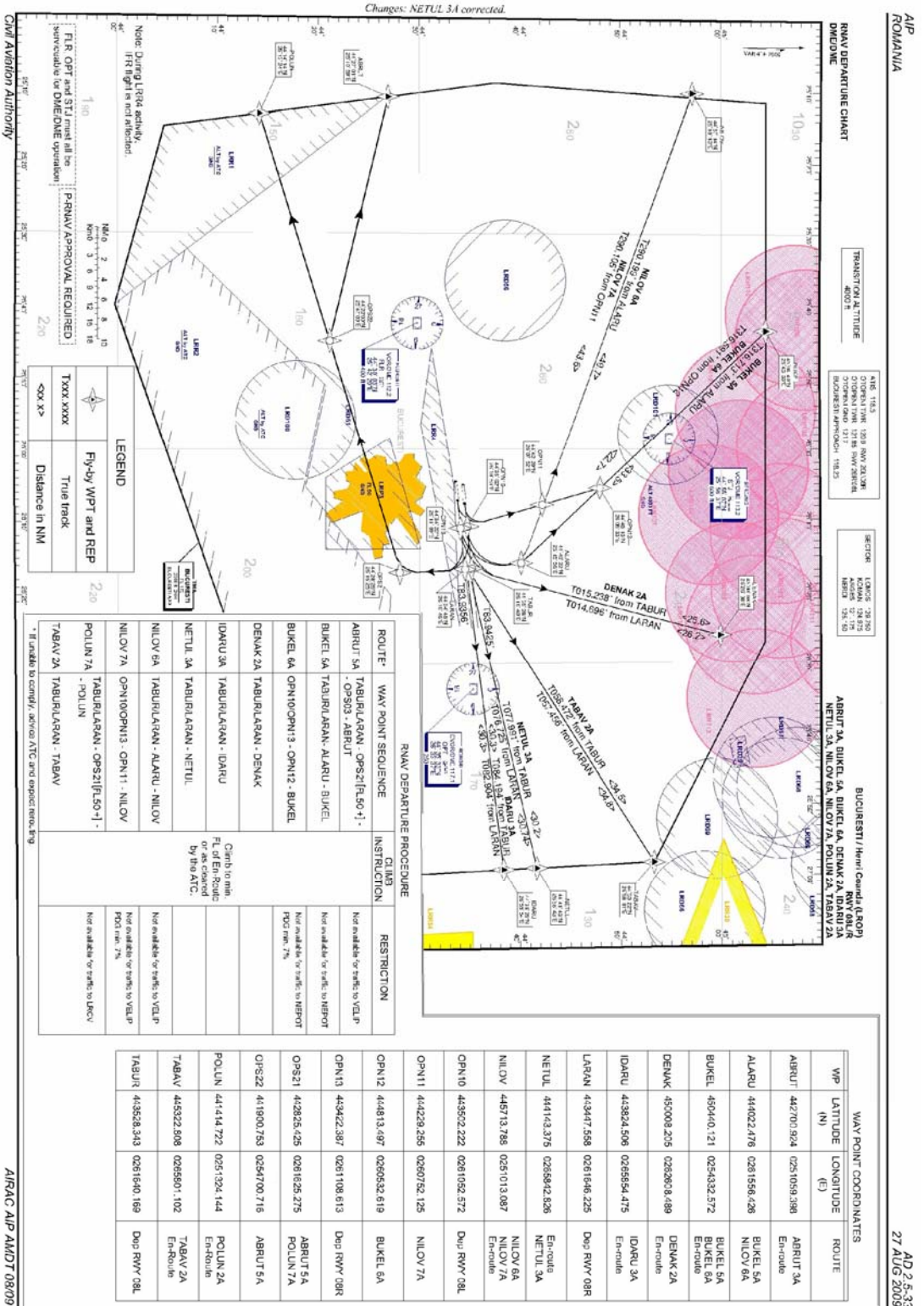

According to the criteria presented it was designed the standard instrument departure route above. From the flight profile obtained after flying this procedure on Microsoft Flight Simulator using PMDG software for a MD 11 aircraft it can be seen that after the second turn the aircraft is at about FL70 – FL80. Thus it was maintained a restriction from ground to FL50. For computing the radius of turn it was considered also a bank angle of 20 deg.

The following formula was used to calculate the rate of turn:

$R = (3431 \tan \alpha) / \pi V$, where V is the TAS in kt;

$\alpha = 20 \text{ deg}$

V= 280 kts, converted from a IAS of 265 kts at an altitude of 3000ft in ISA conditions, and the result is a rate of turn of 1.41 deg/sec.

The radius of turn for an angle of bank of 20 deg in still air is calculated with the formula:

$r = V / (20 \pi R)$ where V is the TAS

R=1.41 deg/sec

V= 280 kts, and the result is a radius of turn of 3.16 NM.

Knowing the value of the radius and the two tangent directions at the circle we can find out the coordinates of the center of the circle. The two waypoints OPS21 and OPS22 are established so that the route of the aircraft over the city to be as small as possible and the segment between the first and the second turn to be optimum for a normal rate of climb.

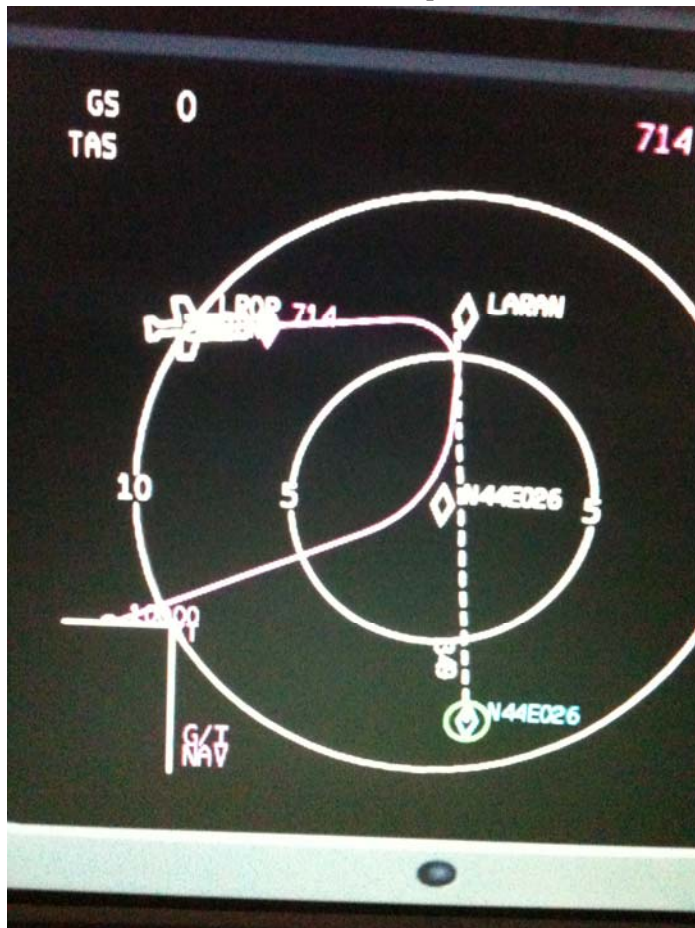

Presenting on the navigation display the new standard instrument departure route



Configuration of the FMS for the actual standard instrument departure route POLUN2A



Configuration of the FMS for the new standard instrument departure route

Comparing the parameters of the two procedures computed by the FMS we can see that the second one brings a reduction of flight time of 3 minutes in order to reach to POLUN waypoint. The minimum safe altitude is also reached for the new procedure.

Considering the fuel flow of 2.353 Kg/sec for the General Electric CF6-80C2 engine, which equip MD 11 aircraft, it can be obtained a fuel economy of 1270 Kg during departure phase from Bucharest Henri Coanda International Airport, runway 08R.

In order to emphasize the benefits of this departure procedure it will be presented a few statistical data using TAROM flights actual schedule.

Flights which usually exit from Bucharest Terminal Area through POLUN waypoint have the following destinations: Istanbul, Beograd, Thessaloniki, Sofia, Venice, Athena, Bari, Barcelona, Madrid, Valencia, Rome, Larnaca, Milano. On average, for these destinations, TAROM has 432 flights per month, which means a fuel economy of 6583680 Kg for one year.

In addition this new procedure could be used by the other companies which operate from Henri Coanda Airport to the destinations specified above. That would conduct to a great reduction of fuel consumption and also of emissions in this way having a significant impact on the environment.

CONCLUSIONS

Considering the results from the simulated flight it can be observed that the procedure respects the safety requirements and minimum obstacle clearance, and the aircraft which are using it are not subject to any unsafe or limit situations.

The benefits are obvious and consist of reducing the total flight time and especially the fuel consumption.

REFERENCES

- [1] O. T. Pleter, *Optimizarea numerica simultana în managementul zborului și al traficului aerian*, Universitatea Politehnica din București, Facultatea de Inginerie Aerospațială, 2004.
- [2] D. Gianazza, *Optimisation des flux de trafic aérien*, L'Institut National Polytechnique de Toulouse, 2004.
- [3] AIP Romania.
- [4] ICAO Doc. 8168, *Procedures for Air Navigation Services – Aircraft Operations*, Volume II – Construction of Visual and Instrument Flight Procedures.
- [5] Introduction to Jeppesen Navigation Charts.