



Al-Khwarizmi Engineering Journal, Vol. 6, No. 2, PP 62-71 (2010)

Al-Khwarizmi  
Engineering  
Journal

## Enhancement of Hoisting System Performance

Yarub O. Naji Al-azzawi      Ra'ad K. Mohammed Al-Duleimi

*Department of Mechatronics Engineering/ Al-Khwarizmi College of Engineering/ University of Baghdad*

(Received 11 February 2010; accepted 30 January 2010)

### Abstract

In this paper it is required to enhance the performance of a mechanical system (here: a Hoisting System) where it is preferred to lift a different payloads with approximately the same speed of lifting and keeping at the same time the good performance, and this of course needs some intelligence of the system which will be responsible on measuring the present load and taking into account the speed and performance desired in order to achieve the requirements or the criteria. The process therefore is a Mechatronics System design which includes a measuring system, a control or automation technique, and an actuating system. The criteria built here in this research using a given Hoist system's characteristics and parameters and changing one of these parameters by the actuator depending on load value (i.e. making a calibration with which there will be a given value of the intentional parameter at which the speed and performance reach the requirements to any load value).

**Key Words:** *Hoisting systems, mechatronics system, automatic system.*

### 1. Introduction

The word mechatronics is composed of "mecha" from mechanism and the "tronics" from electronics. In other word mechatronics mean putting Brain to the mechanism to give it intelligence and work therefore automatically. That what will be happened here in this research. So the aim is to design the electronic circuit that will be the brain of the hoist system (i.e. the mechanism) and this need at first to analyze the mechanical system from mechanical viewpoint and then decide to put the brain.

Rezia M. Molfino, et al show that a new highly automated drilling system able to create holes up to 20 m depth in rocky walls using standard 1.5 m length rods. The drilling system, to be used to automate rocky walls consolidation, has to be positioned in the points of the map earlier defined by the geologist; for this reason it is hosted onto a semiautonomous climbing platform, with rods stored onboard. An automatic system is also required to feed the drilling head with new rods while the hole progresses and to recover the rods once the hole is up.

Nader A. Nayfeh shows that Cranes are

increasingly used in transportation and construction. Increasing demand and faster requirements necessitate better and more efficient controllers to guarantee fast turnaround time and to meet safety requirements. Container cranes are used extensively in ship-to-port and port-to-ship transfer operations. In this work, we will extend the recently developed delayed position feedback controller to container cranes. In contrast with traditional work, which models a crane as a simple pendulum consisting of a hoisting cable and a lumped mass at its end, it is modeled the crane as a four-bar mechanism. The actual configuration of the hoisting mechanism is significantly different from a simple pendulum.

Ziyad N. Masoud and Mohammed F. Daqq indicate that the Input-shaping is a practical open-loop strategy for the control of transient and residual oscillations on cranes, especially those having predefined payload transfer paths and repeated maneuvers. In this paper double-step input-shaping control approach is developed to include maneuvers that involve large hoisting distances and speeds. The approach is based on using the graphical representation of the phase plane of the payload oscillations. The phase plane

is used to derive mathematical constraints to compute the switching times of a double-step acceleration command profile that will result in minimal transient and residual oscillations. The controller design is based on a two-dimensional four-bar-mechanism model of a container crane. For the purpose of controller design, the model is reduced to a constrained double pendulum with variable length hoisting cable and a kinematics angular constraint. The generated commands were based on both a linear and nonlinear frequency approximations of the payload oscillation period. Numerical and experimental results demonstrated that in contrast with the single-step input shaping controllers, which are very sensitive to frequency approximations, the proposed double step controller is less sensitive to small variations in the frequency even with large commanded accelerations. Using this approach, oscillations during and at the end of transfer maneuvers can be reduced to less than 5 cm on a full size model of a 65 ton quay-side container crane.

Hilary Skinner, et al indicates that their report recognizes that the standards relating to the design of cranes and the design of temporary works are changing. It is anticipated that within the next 5 years information routinely available from crane owners for the purposes of structural and geotechnical design will be more detailed and will align with the design philosophy of the Eurocodes for structural design that are due within the next 10 years. Foundation design examples are given that relate to the current approach and to the Eurocode design.

Ziyad N. Masoud shows that Oscillation frequency of crane payloads is the main and most important factor in crane anti-sway control systems design. In the summer of 2005, a Smart Sway Control system (SSC) was installed on a 65-ton quay-side container crane at Jeddah Port. During the calibration phase of the installation, it was observed that heavy payloads combined with the dynamic stretch of the hoist cables had a significant impact on the configuration of the hoisting mechanism and the pattern of oscillation. This introduced considerable change in the oscillation frequency of the payload, which resulted in a significant impact on the performance of the anti-sway control system.

**2. Mechanical System**

The mechanism of the hoisting system is shown in Figure [1]. It consists of three

independent variable and the input is the force  $F$  applied by the DC-motor shown [1].

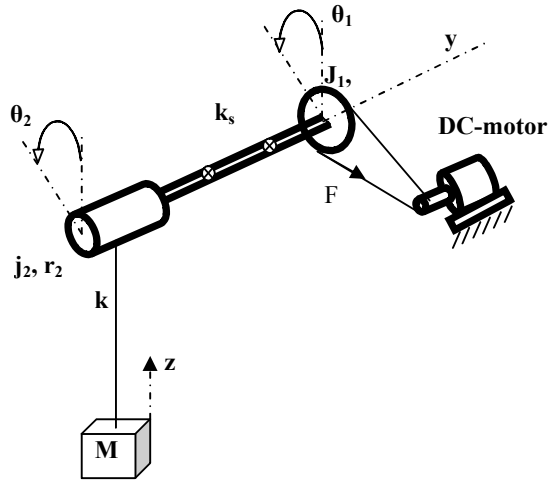

Fig.1. Schematic of Hoisting System.

- $M$  = mass of the payload
- $F$  = force supplied by the motor at the right end of the shaft rises or lowers the mass
- $j_1, r_1$  = moment of inertia and radius of element 1
- $j_2, r_2$  = moment of inertia and radius of element 2
- $k$  = tensile stiffness of the Hoisting cable
- $k_s$  = stiffness of the shaft

Now the free body diagram of the hoisting system is shown in Figure [2] indicating all its independent variables:  $\theta_1, \theta_2, z$

Assuming  $\theta_2 > \theta_1$

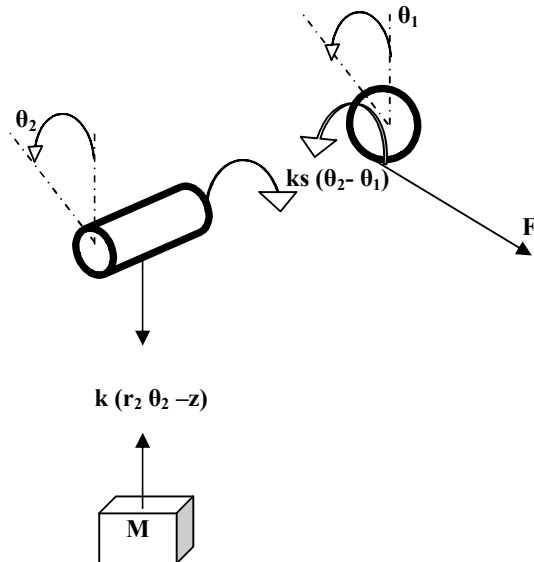

Fig.2. Free body diagram of the Hoisting system.

Applying Newton's second law to the two inertia and the mass, to getting the following equations of motion:

$$\begin{aligned} \sum M_y &= J_1 \ddot{\theta}_1 \\ J_1 \ddot{\theta}_1 &= k_s(\theta_2 - \theta_1) + r_1 F \\ J_1 \ddot{\theta}_1 + k_s \theta_1 - k_s \theta_2 &= r_1 F \end{aligned} \quad \dots(1)$$

$$\begin{aligned} \sum M_y &= J_2 \ddot{\theta}_2 \\ J_2 \ddot{\theta}_2 &= -r_2 k(r_2 \theta_2 - z) - k_s(\theta_2 - \theta_1) \\ J_2 \ddot{\theta}_2 + (r_2^2 k + k_s) \theta_2 - r_2 k z - k_s \theta_1 &= 0 \end{aligned} \quad \dots(2)$$

$$\begin{aligned} \sum F_z &= M \ddot{z} \\ M \ddot{z} &= k(r_2 \theta_2 - z) \\ M \ddot{z} + k z - k r_2 \theta_2 &= 0 \end{aligned} \quad \dots(3)$$

Now in order to analyze the system of equations above, it is preferable to get the state-space of this system as following:

Let :  
 $x_1 = \theta_1, x_2 = \dot{\theta}_1, x_3 = \theta_2, x_4 = \dot{\theta}_2, x_5 = z, x_6 = \dot{z}$

$$\dot{x}_1 = x_2 \quad \dots(4)$$

$$\dot{x}_2 = \frac{1}{J_1} [-k_s x_1 + k_s x_3 + r_1 F] \quad \dots(5)$$

$$\dot{x}_3 = x_4 \quad \dots(6)$$

$$\dot{x}_4 = \frac{1}{J_2} [-(r_2^2 k + k_s) x_3 + r_2 k x_5 + k_s x_1] \quad \dots(7)$$

$$\dot{x}_5 = x_6 \quad \dots(8)$$

$$\dot{x}_6 = \frac{1}{M} [-k x_5 + k r_2 x_3] \quad \dots(9)$$

To analyze the system above it is required to deal with a specific parameters and characteristics (i.e. specific Hoist System). The system selected here is of the following specifications:

$$\begin{aligned} r_1 &= 1 \text{ m}, r_2 = 0.03 \text{ m}, J_1 = \frac{1}{2} M r_1^2, J_2 = 0.01 \text{ kg.m}^2, k_s = 10000 \text{ N.m/rad}, \\ k &= 500000 \text{ N.m}, M = 100 \text{ kg}, F_{\text{supplied}} = 900 \text{ N by the DC motor.} \end{aligned}$$

And the response to the fixed amount of the force supplied by the DC-motor (900N) for lifting minimum and maximum mass (100kg and 1000kg) to this specific system is shown in Figure [3] (a)&(b) respectively:

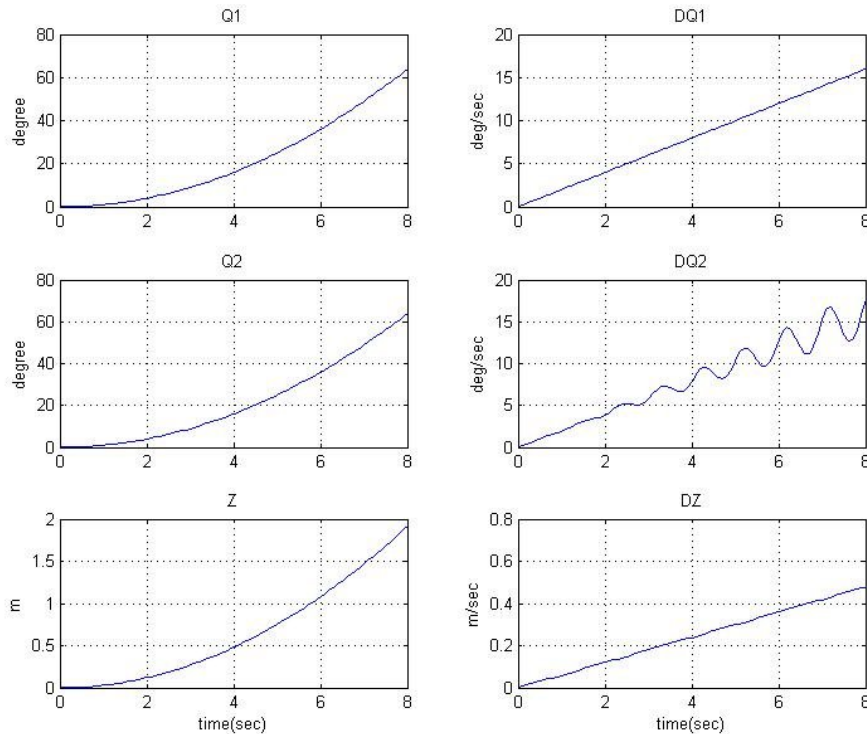

Fig.3.(a). System Response to Lifting 100kg.

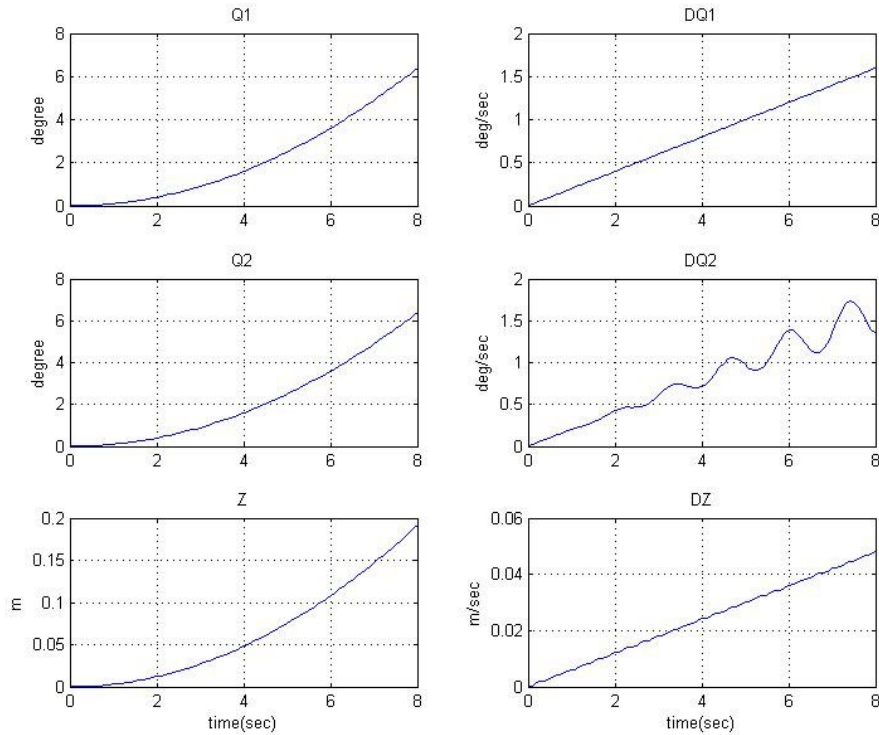

Fig.3. (b). System Response to Lifting 1000kg.

From Figure [3] (a) & (b), the important parameter that would be taken into account is the z parameter which is the response of the Hoisting cable displacement without forgetting the smoothness responses of angles  $\theta_1$  &  $\theta_2$ .

The response of z is smooth in the two figures but the speeds of them are different, where it takes 8 second for the Hoisting system to lift approximately 100kg mass about 2 meter distance whereas to the same period the system lift 1000kg mass about 0.2 meter.

The idea is to unique approximately the amount of the lifting distance to the same period of time with keeping the smoothness of the responses.

### 3. Enhancement Technique

The enhancement technique applied in this research is firstly by propose the mechanism of enhancement which is here by butting an actuator responsible for changing the amount of the right hand side disk radius (r1) proportionally (from 0.1m to 1m) with the amount of mass (100kg to 2000kg) needed to be lift and keeping nearly same speed and the responses smoothness (i.e. the

desired conditions). Table [1] indicates the masses to be lift and the corresponding radius (r1) that will make the desired conditions.

Table 1, Calibration Data of Mass M and Radius r<sub>1</sub> Relationship.

Mass (kg)	Radius r <sub>1</sub> (m)	Displacement z of mass at 3 second (m)
100	1	1.9
125	0.8	1.9
150	0.7	1.8
175	0.6	1.8
200	0.5	1.9
250	0.4	1.9
300	0.3	2
400	0.25	1.8
500	0.2	1.8
600	0.15	2
700	0.12	2
800	0.1	2
900	0.09	1.95
1000	0.07	2

From table [1], it is required to find a mathematical relationship between the mass M and the radius r1 and that may be possible from

representing those data on a figure as shown in Figure [4].

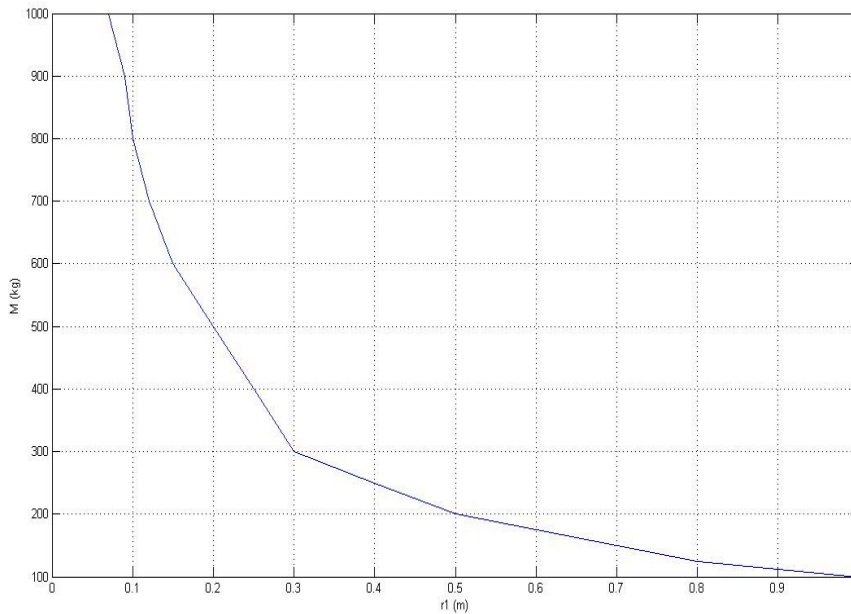

Fig.4. Relation Between Mass M and Radius r<sub>1</sub>.

From Figure [4] the mathematical relationship is similar to the exponential equation (10):

$$r_1 = -0.25 \ln(M/1300) \quad \dots (10)$$

The equation (10) will be taken into account in the following design of the automation technique.

**4. Automation Technique:**

Automation system is represented by a computer that is programmed to instruct the actuator to decide the value of the radius r1 depending on the amount of mass M (given by the operator to the computer) that is to be lifted. The process is indicated in flow-chart shown in Figure [5]:

So the operator gives the value of the amount of the mass M to the Automation program (which is here in MATLAB 7) then the program will decide the value of r1 and instruct the driver of the actuator to do the right action.

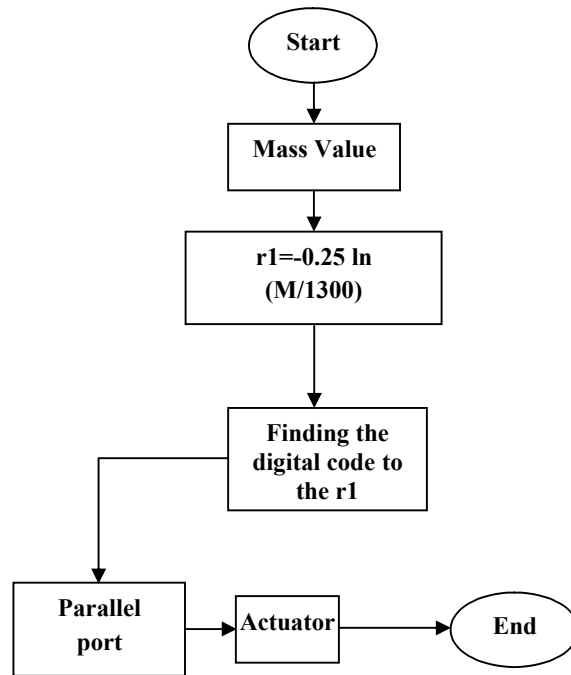

Fig.5. Flow-Chart of Automation Program.

**5. Results and Discussion**

It will be taken three samples of results to the two cases (i.e. with and without automation) as following:

1. Lifting 200kg With Automation as shown in Figure [6](a).

Whereas lifting 200kg without automation is shown in Figure [6](b). From the two Figures [6] (a) and (b), it is really noted that with automation the requirements is nearly achieved whereas without automation is not.

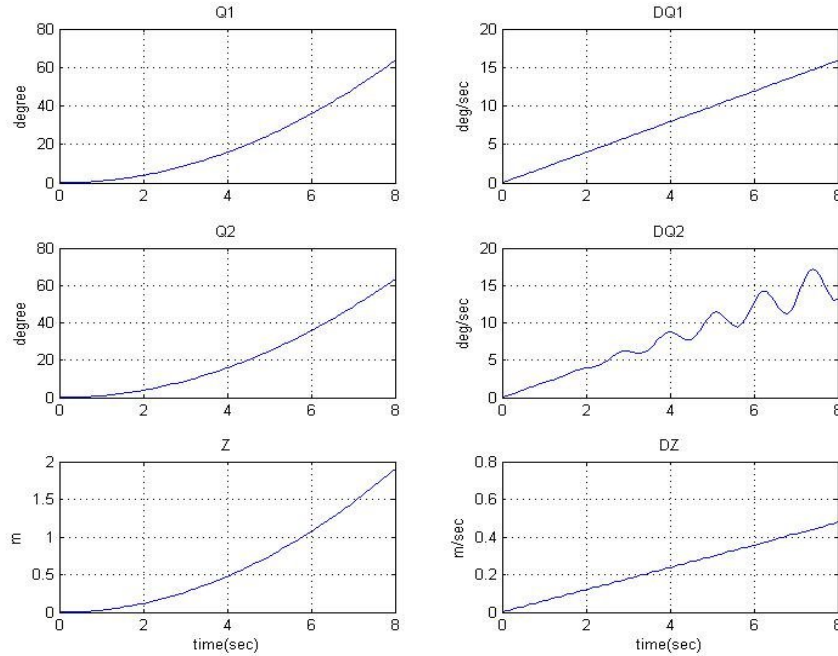

**Fig.6. (a). Lifting 200kg with Automation.**

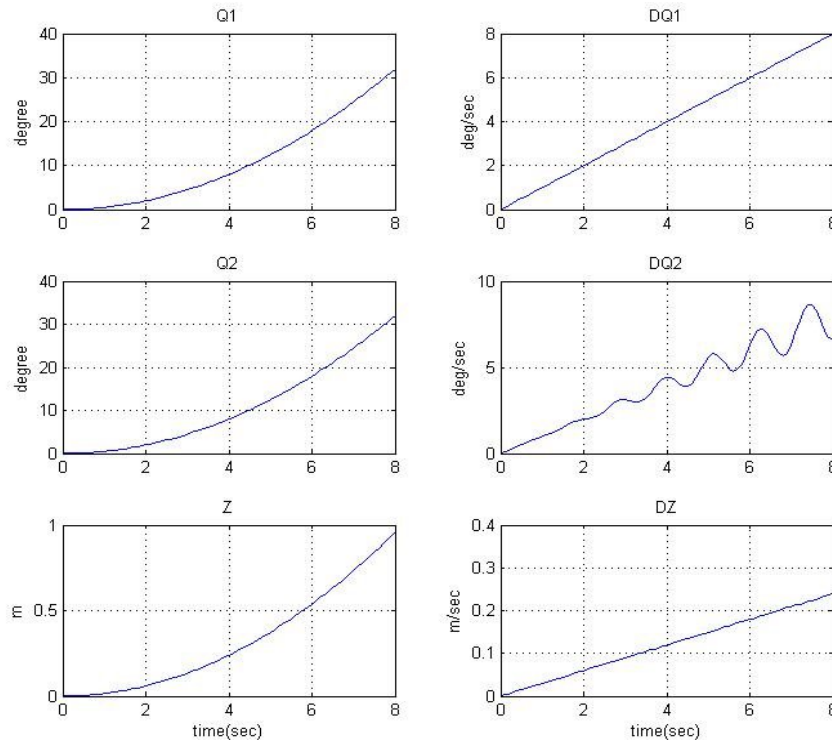

**Fig.6. (b). Lifting 200kg Without Automation.**



2. Lifting 400kg With Automation as shown in Figure [7](a).

Whereas lifting 400kg without automation is shown in Figure [7](b).

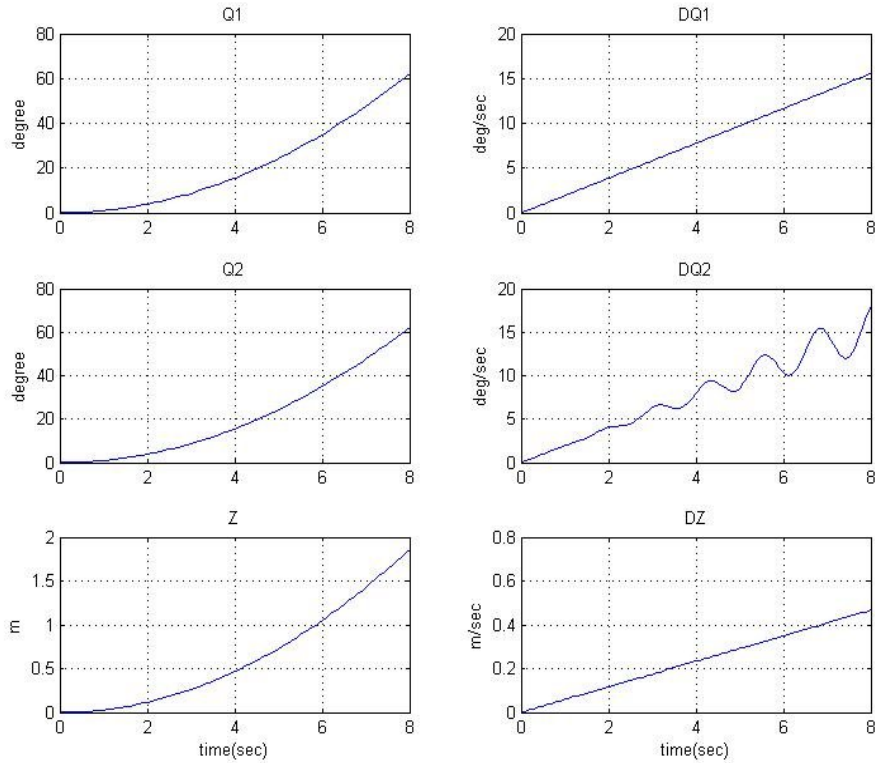

Fig.7.(a). Lifting 400kg with Automation.

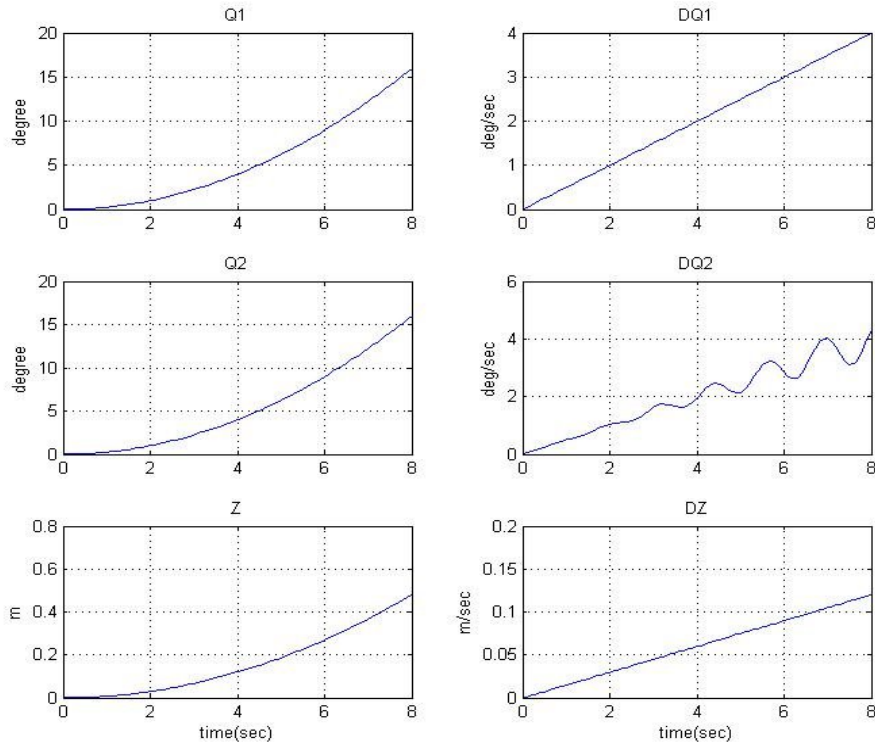

Fig.7.(b). Lifting 400kg Without Automation.

3. Lifting 800kg With Automation as shown in Figure [8](a).

Whereas lifting 800kg without automation is shown in Figure [8](b).

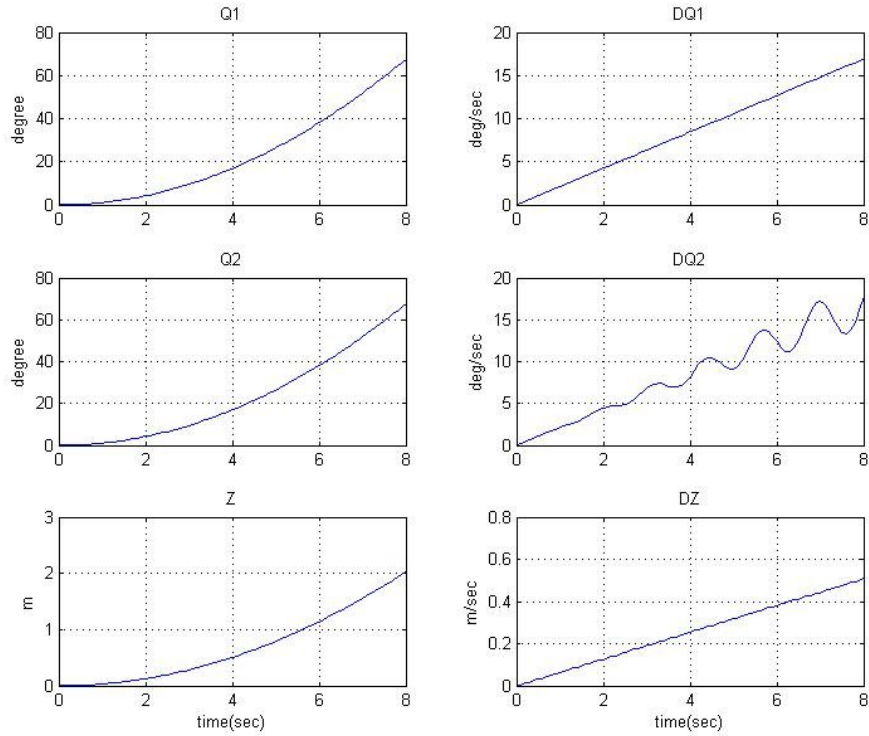

Figure [8](a). Lifting 800kg with automation

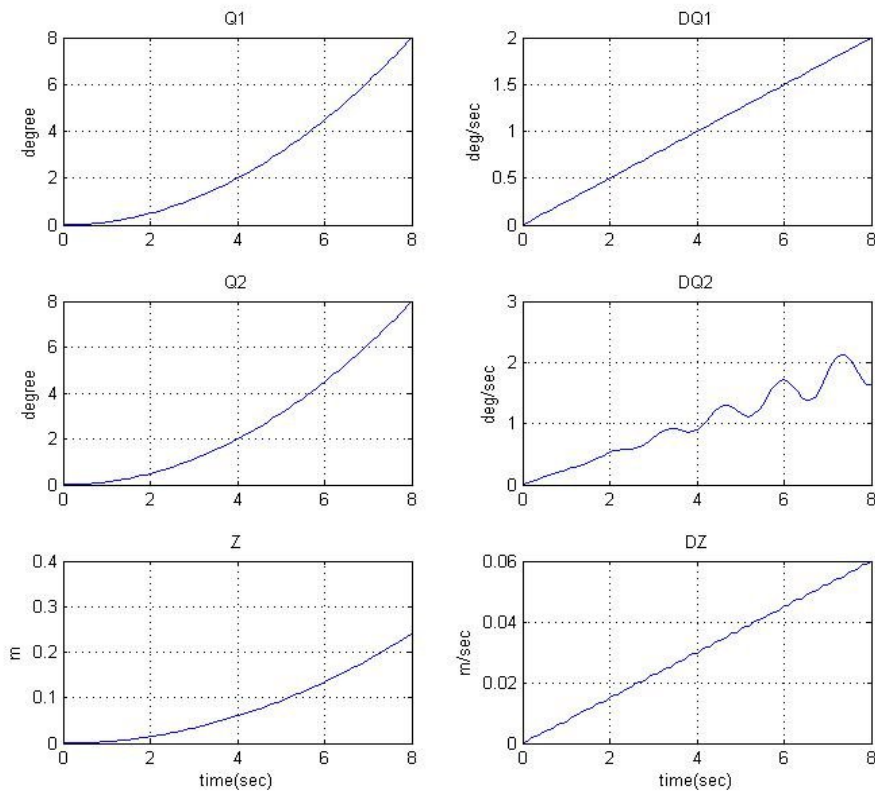

Fig.8.(b). Lifting 800kg without Automation.



## 6. Conclusions and Recommendations

The proposed automatic Hoisting System is well possible to be used in applications of daily life with good enhancements in the whole responses of its parts and also keep it life more time than the first one which without automation. Another thing, the transportation of the loads may be more quickly because it would be reliable.

It is recommended here that other more control technique like feedback control and new intelligence control may be preferred to be more reliable and repeatable. Practical results may be more indicative to the goodness of responses.

## 7. References

- [1] Robert L. Wood & Kent L. Lawrence "Modeling and Simulation of Dynamic Systems" Prentice Hall 1997.
- [2] Rezia M. Molfino, Roberto P. Razzoli, Matteo Zoppi "A Robotized Drilling System for Rocky Wall Consolidation" 22nd International Symposium on Automation and Robotics in Construction ISARC 2005 - September 11-14, 2005, Ferrara (Italy)
- [3] Nader A. Nayfeh "Adaptation of Delayed Position Feedback to the Reduction of Sway of Container Cranes" Thesis, Electrical Eng. Virginia Uni. 2002
- [4] Ziyad N. Masoud , Mohammed F. Daqaq "A Graphical Design of an Input-Shaping Controller for Quay-Side Container Cranes with Large Hoisting: Theory and Experiments" Jordan Journal of Mechanical and Industrial Engineering, 2007
- [5] Hilary Skinner, Tim Watson, Bob Dunkley, and Paul Blackmore " Tower crane stability "Final Contractor's Report of HTC Plant Ltd, USA, October 2005
- [6] Ziyad N. Masoud "Effect of hoisting cable elasticity on anti-sway controllers of quay-side container cranes" Springer Science+Business Media B.V. 2009

## تحسين أداء منظومة رافعة

يعرب عمر ناجي العزاوي رعد كاظم محمد الدليمي

قسم هندسة الميكاترونكس/ كلية الهندسة الخوارزمي/ جامعة بغداد

### الخلاصة

في هذا البحث مطلوب تحسين أداء نظام ميكانيكي (الذي هنا هو نظام رافعية) انه يفضل رفع حمولات مختلفة الاوزان او الكتل بنفس السرعة تقريبا وفي نفس الوقت المحافظة على جودة الاندماج بالطبع يحدث بعض الازدحام للنظام والذي سيكون مسدودا عن قياس الوزن المطلوبه ومن ثم اخذ بنظر الاعتبار السرعة والاداء المرغوبين لتحقيق المتطلبات او المعيار المراد العملية هنا هي تصميم نظام ميكاترونكس والذي يتالف من نظام قياس تقنيته سيطرة او اتمتة ونظام تشغيلي المعيار هنا في هذا البحث بالاعتماد على خصائص ومتغيرات نظام الرفع وتغيير احد هذا البارامترات بواسطة المشغل بالاعتماد على قيمة الحظي بمعنى اخر عمل معايرة والتي به اس يكون هنالك قيمة معينة للمتغير المقصود الذي به سيكون السرعة والاداء المطلوبين لاي قيمة للحمل).