



*Review paper*

UDC: 911.2:628.16  
DOI: 10.2298/IJGI1402129V

## MATHEMATICAL DESCRIPTION OF MATTER EXCHANGE BETWEEN WATER COMPONENTS AND ADSORBING SURFACE OF FILTER MEDIUM OF WATER PURIFICATION UNITS

*Alexey L. Vasiliev* \*<sup>1</sup>, *Lev A. Vasiliev* \*, *Irina V. Bokova* \*, *Alexey L. Kroshilov* \*  
\* Nizhny Novgorod State University of Architecture and Civil Engineering (NNGASU)

Received 21 January 2014; reviewed 28 January 2014; accepted 28 July 2014

**Abstract:** The article presents the theory of mass transfer processes between water polluting components and the adsorbing surface of filter medium of water purification units.

**Key words:** water, water purification, drinking water, natural water, ozone treatment, mass transfer in water purification units

### Introduction

A large number of small-size water purification devices has been developed to provide population and EMERCOM units with water (Vasiliev, 2008; Vasiliev, 2005; Naidenko, 2007). Since the spectrum of waters in terms of contaminants is quite broad, as for their dispersity, solubility and degree of infection by pathogens, the design of small-size water treatment installations should take it into consideration. Moreover, the small-size water purification units must protect from coarse contaminants as well. Otherwise, the subsequent blocks of water purification from fine soluble contaminants will be “intoxicated”. As a rule, stationary granular layers of silica sand, activated charcoal and other sorbents are used for this purpose. But the principal role in the small-size water purification units is played by water disinfection blocks. At present, more often ozone is used as a disinfection agent. It can be easily produced from air provided a source of electricity is available. Together with water ozone is fed via the inlet into a sorbent granular layer.

Today the processes of interaction of ozone molecules with microbes in the flow of water, with dissolved or suspended contaminants, have not been completely studied. This interaction has become significantly complicated, when water is filtered through a granular layer of sorbent. For instance, if the adsorption of ozone molecules on the surface of the sorbent’s macro- and micropores is higher

---

<sup>1</sup> Correspondence to: vasilievlev@rambler.ru

than that of the microbes, water disinfection should be done before the granular layer. Below the analytical and numerical data on mass transfer of a water component adsorbed by the surface of the granular layer's macro- and micropores are given. The analytical findings were obtained with the help of the Henry sorption isotherm. The numeric and asymptotic data were obtained for the increasing concentration of the Langmuir convex isotherm.

The NNGASU Chair of water supply and sewage has developed a device for water purification and ozonation (Figure 1) (Koposov, 2011). It consists of three blocks. The bottom cone section of the installation is made in the form of a hydrocyclone for cleaning influent water from coarse suspended particles. The axially arranged discharge zone for ozone production and filter cartridge with a granular layer of activated charcoal are located in the top section of the device.

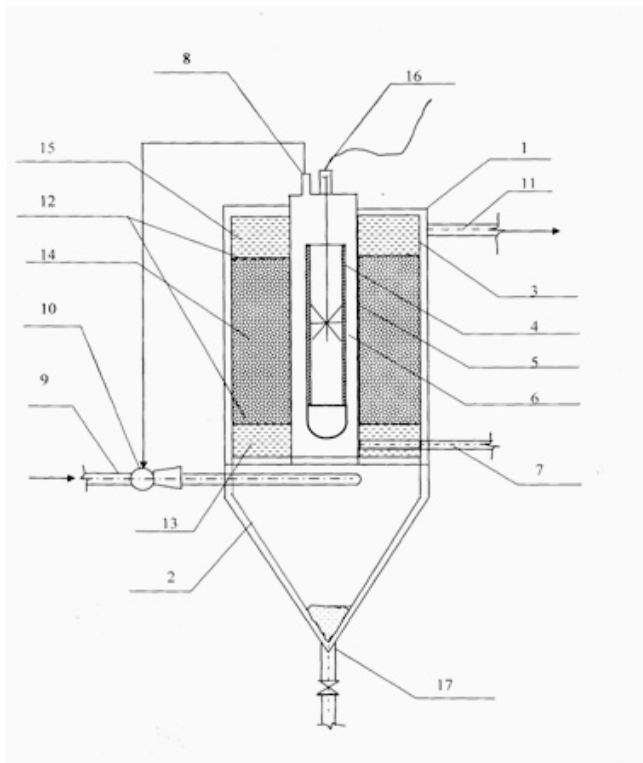

Figure 1. Water purification installation 1. body; 2. bottom cone section; 3. cooling jacket; 4. high voltage electrode; 5. low voltage electrode; 6. discharge zone; 7. compressed dried gas inlet pipe; 8. ozone inlet pipe; 9. influent water inlet pipe; 10. ejector; 11. ozonized water outlet pipe; 12. mesh; 13. influent water section; 14. cartridge with filter medium; 15. purified water section; 16. high voltage feeder

This paper addresses processes of mass transfer in a stationary granular layer of activated charcoal. Quite a number of articles (Aerov, 1979; Lykov, 1978; Lykov, 1963) were dedicated to the study of thermal mass transfer in a stationary granular layer. Conventionally, they can be divided into two groups. In the first type local potentials of mass transfer (temperature, component concentration) of liquid and solid phases are different. Researches in these papers are dedicated mainly to the determination of internal coefficients of heat and mass transfer. In the works of the second type, being an extreme case of the first type at very large internal coefficients of heat and mass transfer, temperatures of the solid body or component concentrations in the micropores of the solid body and liquid are almost the same at any point of the granular layer. A similar stationary problem of heat transfer was solved, for example, in (Isachenko, 1981). Mathematically, the problems of the first type are similar to those of the sorption of porous sorbents.

### Methodology

The granular layer of activated charcoal has porosity  $\Pi=0,37-0,42$ . Grains of this layer represent a capillary-porous material. According to (Lykov, 1978) this material possesses macro capillaries of radius  $r \geq 10^{-5}$  cm and micro capillaries  $r \leq 10^{-5}$  cm, activated charcoal density  $\rho=1780$  kg/m<sup>3</sup>, volume of macro capillaries 0.87 m<sup>3</sup>/m<sup>3</sup>, volume of micro capillaries 0.856 m<sup>3</sup>/m<sup>3</sup>. A volumetric part of the micro capillaries equals 0.986. The surface and volume of macro and micro capillaries of the activated charcoal grains determine significantly the statics (volume) and kinetics of sorption. At the water flow via a granular layer  $V=150$  L/h=0.0000417 m<sup>3</sup>/s and cross-section area of the granular layer  $F=0.0311$  m<sup>2</sup> the water velocity at the layer inlet will be  $w_0=V/F=0.0000417/0.0311=0.00134$  m/s. The water velocity in the layer  $w=w_0/\Pi=0,00134/0,4=0.00335$ m/s. The diffusion coefficient for liquids  $D_i \sim 10^{-9}$  m<sup>2</sup>/s. If the equivalent diameter of the activated charcoal grains  $\sim 5$  mm, the diffusion Péclet number will constitute  $Pe=wd/D_i=3.35*5*10^3 \gg 1$ .

Since the Péclet number is large, the diffusion mass transportation can be neglected as compared with the convection transportation.

Let us denote the quantity of the  $i$ -component of water absorbed by a unit of volume of activated charcoal with  $C_{iA}(x,\tau)$ . And the concentration of the water  $i$ -component in the pores of the activated charcoal granular layer – as  $C_i(x,\tau)$ . Where  $x$  is a coordinate along the water flow running through the layer,  $\tau$  is the time. Let us calculate the mass balance of the water  $i$ -component during the infinitely small period of time  $d\tau$  for the infinitely fine granular layer  $dx$  of the cross-section area  $F$ . The mass  $wC_{iX}Fd\tau$  of the  $i$ -component is taken to the layer

during this time. For the same time, the mass of the *i*-component outflowing through the cross-section (*x*+*dx*) is  $wC_{i(x+dx)}F d\tau$ . The difference between the intake and discharged mass is  $(C_{ix}-C_{i(x+dx)})wF d\tau$ . Since the component concentration is a continuous function of the coordinate *x*, it can be presented as a Taylor series. Because *dx* is small, this expansion can be limited by just two

first terms of the series (linear approximation)  $C_{i(x+dx)} = C_{ix} + \frac{\partial C_i}{\partial x} dx$ . Then

the difference between the intake and discharged mass is  $-\frac{\partial C_i}{\partial x} dx \cdot F \cdot w d\tau$ .

According to the principle of mass conservation, this mass will increase concentrations of the adsorbed component and that in the pores of the granular layer:

$$\frac{\partial(C_{iA} + C_i)}{\partial \tau} d\tau \cdot dx \cdot F$$

Equaling these two relations and reducing them by  $F dx d\tau$ ,

$$-w \frac{\partial C_i}{\partial x} = \frac{\partial(C_{iA} + C_i)}{\partial \tau} \tag{1}$$

There are two unknown functions in this equation; therefore, we add an equation of kinetic sorption in it (Gerasimov Ya. et al., 1970):

$$\frac{\partial C_{iA}}{\partial \tau} = \beta(C_i - C_{iR}) \tag{2}$$

where  $\beta$  is the kinetic coefficient;  $C_{iR}$  is the concentration of component being in equilibrium with the adsorbed component.

The relation between  $C_{iA}=f(C_{iR})$  is called an isotherm of sorption. There are various types of sorption isotherms (Gerasimov et al.,1970). For analysis in this

paper the Henry isotherm  $C_{iA} = \frac{1}{\gamma} C_{iR}$  is used, where  $1/\gamma$  is the constant coefficient. It represents an individual case of the Langmuir isotherm for small concentrations of component:

$$C_{iA} = \frac{C_{i0} C_{iR}}{\gamma(C_{i0} + p C_{iR})}$$

where  $p$  is the constant of the adsorption balance.

For small concentrations of component  $p \frac{C_{iR}}{C_{i0}} \ll 1$ , the Langmuir isotherm degrades into the Henry isotherm. For example, application the Langmuir isotherm would have made the system of equations (1) and (2) non-linear, excluding analytical solution and requiring numerical integration.

Substituting the Henry isotherm in equation (2) and neglecting  $C_i$  as compared with  $C_{iA}$ , we obtain:

$$-w \frac{\partial C_i}{\partial x} = \frac{\partial C_{iA}}{\partial \tau}, \quad (3)$$

$$\frac{\partial C_{iA}}{\partial \tau} = \beta \cdot (C_i - \gamma C_{iA}) \quad (4)$$

Let us add initial and boundary conditions to these differential equations:

$$C_{iA}(x, 0) = 0, \quad (5)$$

$$C_i(0, \tau) = C_{i0} \quad (6)$$

If we exclude  $C_{iA}(x,t)$  from the system of differential equations (3) and (4), we will get an equation to calculate fields of component concentrations  $C_i(x,t)$  in the pores of the activated charcoal granular layer. And the other way round, if  $C_i(x,t)$  is excluded from the system of differential equations (3) and (4), an equation to calculate the concentration fields  $C_{iA}(x,t)$  of adsorbed components by the grains of the activated charcoal will be obtained. Since in our experiment the concentrations of components in water were measured on the outlet of the granular layer, it makes sense to exclude  $C_{iA}(x,t)$  from the system. For this purpose, differentiating equation (3) by time and using equation (4), we obtain:

$$-w \frac{\partial C_i}{\partial x \cdot \partial \tau} = \beta \frac{\partial C_i}{\partial \tau} - \beta \gamma \frac{\partial C_{iA}}{\partial \tau} = \beta \frac{\partial C_i}{\partial \tau} + \beta \gamma w \frac{\partial C_i}{\partial x} \quad (7)$$

Finally, we have the differential equation for calculating concentration fields of components in the pores of the granular layer:

$$\frac{\partial C_i}{\partial x \cdot \partial \tau} + \frac{\beta}{w} \frac{\partial C_i}{\partial \tau} + \beta \gamma \frac{\partial C_i}{\partial x} = 0 \quad (8)$$

To find the initial condition  $C_i(x,0)$ , taking into account eq. (4) let us assume in equation (3)  $\tau=0$ , then the differential equation will be as follows:

$$-w \frac{\partial C_i(x,0)}{\partial x} = \beta \cdot C_i(x,0) \tag{9}$$

Dividing its variables and integrating them, taking into account boundary condition (6), we obtain the initial condition:

$$C_i(x,0) = C_{i0} \cdot \exp\left(-\frac{\beta}{w} \cdot x\right) \tag{10}$$

The boundary condition accordingly has the following form:

$$C_i(0, \tau) = C_{i0} \tag{11}$$

A problem of granular layer heating with gas at a constant temperature at the layer’s inlet is solved by the same differential equation (8). The solution of this equation in the form of series was obtained by Schumann (Aerov, 1979). Erugin (Lykov, 1963) has found the most general solution of this equation, which for our case his the following view:

$$\frac{C_i(X,t)}{C_{i0}} = e^{-X} \left[ e^{-t} I_0(2\sqrt{Xt}) + \frac{1}{X} \int_0^{Xt} e^{-\frac{\tau}{X}} I_0(2\sqrt{\tau}) d\tau \right], \tag{12}$$

where  $X = \frac{\beta \cdot x}{w}$ ,  $t = \frac{\beta \tau}{\gamma}$  are the non-dimensional coordinates and time respectively.  $I_0(u)$  is the imaginary zero-order Bessel function of the first kind.

Equation (12) for large periods of time  $Z$  can be arranged in other way, more convenient for calculations. For this purpose let us re-write the integral in the right-hand part of eq. (11) introducing new variable  $2\sqrt{\tau} = y$ :

$$\int_0^{Xt} e^{-\frac{\tau}{X}} I_0(2\sqrt{\tau}) d\tau = \frac{1}{2} \int_0^{2\sqrt{Xt}} e^{-\frac{y^2}{4X}} I_0(y) y dy \tag{13}$$

In (Gradstein, 1971) the integral was calculated for  $\tau=\infty$ , which at  $v=0$ ;  $\alpha=1/4X$ ;  $\beta=1$ ;  $\gamma=0$  is equal to integral (12) at  $t=\infty$ :

$$\frac{1}{2} \int_0^{\infty} x e^{-\alpha x^2} I_{\nu}(\beta x) J_{\nu}(\gamma x) dx = \frac{1}{4\alpha} \exp\left(\frac{\beta^2 - \gamma^2}{4\alpha}\right) J_{\nu}\left(\frac{\gamma\beta}{2\alpha}\right); \quad (14)$$

$$\frac{1}{2} \int_0^{\infty} y e^{-\frac{y^2}{4X}} I_0(y) \cdot 1 \cdot dy = X \exp(X) \quad (15)$$

But integral (12) can be expressed as a difference of two integrals:

$$\frac{1}{2} \int_0^{2\sqrt{Xt}} (\dots) = \frac{1}{2} \int_0^{\infty} (\dots) - \frac{1}{2} \int_{2\sqrt{Xt}}^{\infty} (\dots) \quad (16)$$

Then equation (11) can be written in the form:

$$\frac{C_i(X, t)}{C_{i0}} = e^{-X} \left[ e^{-t} I_0(2\sqrt{Xt}) + e^X - \frac{1}{2X} \int_{2\sqrt{Xt}}^{\infty} e^{-\frac{y^2}{4X}} I_0(y) y dy \right] \quad (17)$$

At large values of  $2\sqrt{Xt} \geq 2$ , the Bessel function under the integral sign can be replaced by its asymptotic formula:

$$\frac{C_i(X, t)}{C_{i0}} = e^{-X} \left[ e^{-t} I_0(2\sqrt{Xt}) + e^X - \frac{1}{2X} \int_{2\sqrt{Xt}}^{\infty} e^{-\frac{y^2}{4X}} \frac{e^y \cdot \sqrt{y}}{\sqrt{2\pi}} dy \right] \quad (18)$$

In work (Tikhonov, 1972) the system of non-dimensional differential equations of sorption was integrated numerically by the finite difference method:

$$\frac{\partial \bar{u}}{\partial X} = -\frac{\partial v}{\partial t}; \quad (19)$$

$$\frac{\partial v}{\partial t} = (\bar{u} - z) \quad (20)$$

where  $\bar{u} = \frac{C_i}{C_{i0}}$  is the non-dimensional concentration of the i-component.

For the non-dimensional Langmuir isotherm:

$$v = f_1(z) = \frac{z}{\gamma^2(1 + pz)} \tag{21}$$

at the boundary and initial conditions:

$$u(0,t) = 1, \quad v(X,0) = 0. \tag{22}$$

Here  $X = \frac{x\beta}{w}$ ;  $t = \frac{\tau\beta}{\gamma}$ ;  $\bar{u} = \frac{C_i}{C_{i0}}$ ;  $z = \frac{C_{iR}}{C_{i0}}$ ;  $v = \frac{C_{iA}}{C_{i0} \cdot \gamma}$  are non-dimensional values.

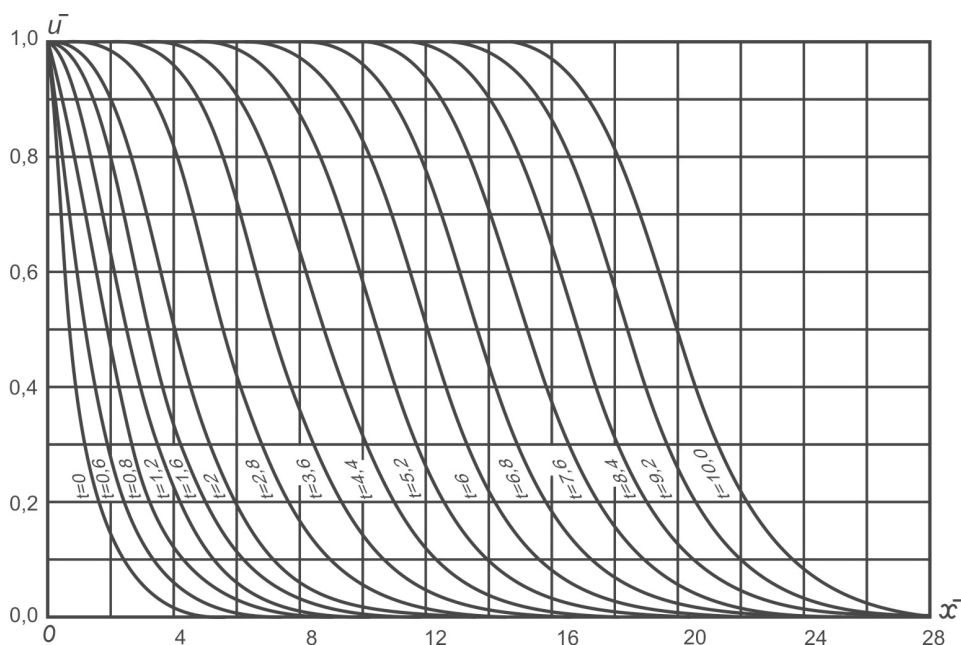

Figure 2. Dependence of the non-dimensional concentration of components on the non-dimensional coordinates and time

The calculation results for the values of the non-dimensional time  $0 \leq t \leq 10$  are presented in Figure 2. The same graph presents the calculation results of relation (12) in the field of the Henry isotherm for  $\pi \leq 0.1$ .

For the values of the non-dimensional time  $t \geq 10$ , asymptotic solutions for the component concentration fields were constructed (Tikhonov, 1972), unfortunately, with some mistakes, which have been corrected in this work.

Let us solve relation (21) with regard to  $z$ :



$$z = f_1^{-1}(v) = F(v) = \frac{\gamma^2 v}{(1 - \gamma^2 v p)} \quad (23)$$

The asymptotic solutions for the fields of component concentrations were found in the forms of propagating concentration waves

$$\begin{aligned} \tilde{u} &= \psi(\xi), \quad \xi = X - \sigma t, \\ \tilde{v} &= \varphi(\xi), \end{aligned} \quad (24)$$

where  $\sigma$  is the non-dimensional velocity of wave propagation.

These fields (24) are valid for large distances (at  $x \rightarrow \infty$ ) or for large periods of time (at  $t \rightarrow \infty$ ):

$$\bar{u}(X, t) = \tilde{u} = \psi(X - \sigma t); \quad v(X, t) = \tilde{v} = \varphi(X - \sigma t).$$

At these distances or periods of time the concentrations of components must satisfy the following conditions of equilibrium:

$$v = f_1(\bar{u}) = \frac{\bar{u}}{\gamma^2(1 + p\bar{u})} \text{ or } \bar{u} = F(v) = \frac{\gamma^2 v}{(1 - \gamma^2 v p)}.$$

From the boundary and initial conditions (22) we have:

$$\bar{u}|_{t=\infty}^{X=0} = \psi(-\infty) = 1; \quad v|_{t=\infty}^{X=0} = \varphi(-\infty) = f_1(1) = \frac{1}{\gamma^2(1 + p)}; \quad (25)$$

$$v|_{t=0}^{X=\infty} = \varphi(+\infty) = 0; \quad \bar{u}|_{t=0}^{X=\infty} = F(0) = 0. \quad (26)$$

Substituting solutions (24) in relations (19), (20), and taking into consideration (23), we obtain:

$$\frac{\partial \psi}{\partial \xi} = \sigma \frac{\partial \varphi}{\partial \xi}; \quad (27)$$

$$-\sigma \frac{\partial \varphi}{\partial \xi} = \psi - F(\varphi) = \psi - \frac{\gamma^2 \varphi}{(1 - \gamma^2 p \varphi)}. \quad (28)$$

Comparing (27) and (26), we have:

$$\psi(\xi) - \sigma \varphi(\xi) = 0. \quad (29)$$

From relation (25) we will obtain a non-dimensional velocity of propagation of the concentration wave of the i-component:

$$\sigma = \frac{\psi(\xi)}{\varphi(\xi)} \Big|_{\xi=-\infty} = \frac{1}{f_1(1)} = \gamma^2 (1 + p) \tag{30}$$

Dividing the variables in (28), taking into account (29), we have:

$$-\sigma \frac{d\varphi}{\sigma\varphi - F(\varphi)} = -\sigma \frac{d\varphi}{\sigma\varphi - \frac{\gamma^2\varphi}{1 - \gamma^2 p\varphi}} = d\xi \tag{31}$$

Integrating relation (31), we obtain:

$$\begin{aligned} \omega(\varphi) &= \xi - \xi_0, \\ \omega(\varphi) &= -\sigma \int \frac{(1 - \gamma^2 p\varphi)d\varphi}{\gamma^2\varphi - \sigma\varphi(1 - \gamma^2 p\varphi)} + B = \\ &= \frac{\sigma}{\sigma - \gamma^2} \left[ \frac{\gamma^2}{\sigma} \ln[(\sigma - \gamma^2) - \sigma\gamma^2 p\varphi] - \ln \varphi \right] + B = \xi - \xi_0 \end{aligned} \tag{33}$$

Substituting formula (30) in relation (33), we have:

$$\omega(\varphi) = \frac{1+p}{p} \left[ \frac{1}{1+p} \ln(\gamma^2 p - \gamma^4(1+p)p\varphi) - \ln \varphi \right] + B = \xi - \xi_0 \tag{34}$$

In this relation  $\omega(\varphi)$  changes from  $+\infty$  to  $-\infty$  at the change of  $\varphi$  from 0 to  $f_1(1)$ . To determine the constant B, let us choose it in such a way that:

$$\varphi^* = \frac{1}{2} f_1(1) = \frac{1}{2} \cdot \frac{1}{\gamma^2(1+p)} = \frac{1}{2} \cdot \frac{1}{\sigma}, \quad \omega(\varphi^*) = 0,$$

then the constant B will equal:

$$B = -\frac{1+p}{p} \left[ \frac{1}{1+p} \ln \frac{\gamma^2 p}{2} - \ln \frac{1}{2\gamma^2(1+p)} \right] \tag{35}$$

Substituting (35) in relation (34), we obtain finally:

$$\omega(\varphi) = \frac{1+p}{p} \left[ \frac{1}{1+p} \ln 2 [1 - \gamma^2(1+p)\varphi] - \ln 2 \gamma^2(1+p)\varphi \right] = \xi - \xi_0 \quad (36)$$

The value of the constant  $\xi_0$  in relation (32) we will calculate according to the formula:

$$\xi_0 = -\frac{1}{f_1(1)} \int_0^{f_1(1)} \omega(\varphi) d\varphi = \ln 2 - 1 = -0.3069, \quad (37)$$

Formula (36) can be re-written in the form:

$$\omega(\varphi) = \frac{\sigma}{\sigma - \gamma^2} \left[ \frac{\gamma^2}{\sigma} \ln 2 [1 - \sigma\varphi] - \ln 2 \sigma\varphi \right] = \xi - \xi_0 \quad (38)$$

The asymptotic solutions for the fields of component concentrations have the form, taking into account relations (24) and (29):

$$\tilde{v}(X, t) = \omega^{-1}(X - \sigma t + 0.3069) = \varphi(X, t), \quad (39)$$

$$\tilde{u}(X, t) = \sigma \omega^{-1}(X - \sigma t + 0.3069) = \psi(X, t). \quad (40)$$

Unfortunately, formula (38) cannot clearly express  $\varphi = \varphi(\xi - \xi_0)$ .

## Results

As an example of the above data application, let us consider the test results presented in Tables 1 and 2. They contain the experimental data on the concentration of water pollutants on the inlet and outlet of the water purification units. The design of the prototype has no cyclone on the inlet. Therefore, the concentrations of water pollutants on the inlet of the granular layer of the activated charcoal are available. In a new invented water purification unit there is a hydrocyclone on its inlet, and the concentrations of water pollutants on the inlet of the activated charcoal granular layer are unknown, the same as on the outlet of the hydrocyclone. Let us calculate these concentrations.

The time of water front passing through a layer of activated charcoal of the height  $h=0.3$  m at the flow velocity in the layer  $w=0.00335$ m/s is  $\tau=89.55$  s=1.493 min=0.0249 hour=0.001 day. Therefore, the end of this period of time can be taken as the initial conditions for pollutant concentration in the liquid in pores. As it is evident from Table 2, the change of water pollutant concentration at the outlet of the prototype is insignificant during the first three days.

Therefore, these concentrations can be extrapolated to the beginning of the first day. In this case we obtain turbidity 1.3 mg/L, oxidizability 1.7 mg O<sub>2</sub>/L, total organic carbon 8.85 mg/L. Using relation (10), we will obtain the formula to calculate kinetic coefficients of the rate of water pollutant adsorption:

$$\beta_i = \frac{w}{h} \ln \frac{C_{i0}(0,0)}{C_{ih}(h,0)} \tag{41}$$

Calculations according to this formula give the following results: turbidity  $\beta_T=0.050531 \text{ s}^{-1}$ , oxidizability  $\beta_{OX}=0.020851$ , total organic carbon  $\beta_{TOC}=0.3998$ , total microbial count, assuming 1 for 0,  $\beta_{MIC}=0.101673$ .

Table 1

Water quality parameter	Influent water	Cone angle $\alpha$ , degree						
		20	25	30	35	37	40	45
Turbidity, mg/L	120	1,0	0,73	0,49	0,51	1,27	1,3	1,41
Oxidizability, mgO <sub>2</sub> /L	11,0	1,8	1,75	1,65	1,6	1,87	1,95	2,0
Total organic carbon, mg/L	13,2	6,95	7,76	6,65	6,61	6,99	7,12	7,2
Total microbial count, units/mL	9000	0	0	0	0	0	0	0

Table 2

Water quality parameter	Influent water	Prototype						New design			
		Experiment time, days						Experiment time, days			
		1	3	5	7	10	1	3	5	7	10
Turbidity, mg/L	120	1,4	1,55	1,9	3,5	16	0,5	0,5	0,7	0,9	1,2
Oxidizability, mgO <sub>2</sub> /L	11	1,95	2,39	3,71	4,92	5,65	1,64	1,72	1,83	1,91	2,16
Total organic carbon, mg/L	13,2	8,95	9,15	9,76	10,53	11,54	6,63	6,88	7,16	7,32	7,92
Total microbial count, units/mL	9000	0	0	19	41	93	0	0	0	0	0

Knowing the kinetic coefficients of water pollutants with the help of relation (42):

$$C_{i0}(0,0) = C_{ih}(h,0) \exp\left(\frac{\beta_i h}{w}\right) \tag{42}$$

we can determine concentrations of pollutants on the outlet of the hydrocyclone or on the inlet on the granular layer of a new design of the water purification unit. The calculations gave the following results: turbidity  $C_T 0=46.16 \text{ mg/L}$ ,

oxidizability  $C_{OX,0}=10,35$  mg  $O_2/L$ , total organic carbon  $C_{TOC}=9.844$  mg/L. As it was expected, the hydrocyclone had the largest effect on the water turbidity, reducing it in 2.6 times, while the oxidizability reduced in 1.06 times, and the total organic carbon – in 1.34 times.

### Conclusion

The offered methods of calculation permit to forecast quality parameters of treated water and determine them based on those of influent water; they can be applied in any other similar technological processes.

### References

- Aerov, M., Todes, O., Narinsky D. (1979). *Apparatuses with a stationary granular layer*. Leningrad: Chemistry, 175 pp.
- Gerasimov, Ya. et al. (1970). *Course of physical chemistry*. T. I, Moscow: Chemistry, 592 pp.
- Gradstein, I., Ryzhik, I. (1971). *Tables of integrals, sums, series and products*. Moscow: Science, 1107 pp.
- Isachenko, V., Osipova, V., Sukomel, A. (1981). *Heat transfer*. Moscow: Energoizdat, 417 pp.
- Koposov, E., Vasiliev, A., Vasiliev, L., Bokova, I., Sharova, O. (2011). Device for water treatment. Useful model patent 102 612 RF, C02F 1/78, C01B 13/11 Date of application 21.10.09, published 10.03.11. *Bul. № 7*.
- Lykov, A. (1978). *Heat and mass exchange*, Reference book. Moscow: Energy, 479 pp.
- Lykov, A., Mikhailov, Yu. (1963). *The theory of heat and mass transfer*. Moscow: Higher school, 535 pp.
- Lykov, A. (1967). *Theory of heat conductivity*. Moscow: Higher school, 600 pp.
- Naidenko, V., Vasiliev, A., Vasiliev, L., Bokova, I., Kroshilov (2007). Device for water treatment. Pat. 2311348 RF, C02 F1/78. Date of application 03. 08.05, published 27.11.07. *Bul. № 33*.
- Tikhonov, A., Samarsky, A. (1972). *Equations of mathematical physics*. Moscow: Science, 735 pp.
- Vasiliev, A., Koposov, E., Vasiliev, L. (2008). Ensuring quality water supply to population and special forces in emergency situations. *Privolzhsky Scientific Journal*. N.Novgorod, NNGASU, № 2, 13–24.
- Vasiliev, A., Vasiliev, L., Podgornova, O., Bokova, I. (2005). Device for water ozone treatment. Pat. 2253609 RF, C 01 B 13/11, C 02 F 1/78. Date of application 24.06.04, published 10.06.05. *Bul. № 16*.