

# A COMPARATIVE STUDY ON EXPERIMENTAL AND SIMULATION RESPONSES OF CR-39 TO NEUTRON SPECTRA FROM A $^{252}\text{Cf}$ SOURCE

by

**Mitra GHERGHEREHCHI<sup>1</sup>, Hyun Wook KIM<sup>1</sup>, Yoon Sang KIM<sup>2</sup>,  
Hossein AFARIDEH<sup>3</sup>, and Jong Seo CHAI<sup>1\*</sup>**

<sup>1</sup>Department of Electronic and Electrical Engineering, Sungkyunkwan University, Suwon, South Korea

<sup>2</sup>Korea University of Technology and Education, Cheonan, South Korea

<sup>3</sup>Department of Nuclear Engineering and Physics, Amirkabir University of Technology, Tehran, Iran

Scientific paper

DOI: 10.2298/NTRP1303293G

A simulation of the interaction of neutrons emitted from a  $^{252}\text{Cf}$  source with a CR-39 detector is presented in this paper. Elastic and inelastic neutron interactions occur with the constituent materials of the CR-39 detector. Inelastic scatterings only consider (n,  $\alpha$ ) and (n, p) reactions. Fast neutrons tracks are, mainly, produced by recoil particle tracks in the plastic nuclear track detector as a result of the elastic scattering reaction of neutrons with the constituent materials of the solid-state nuclear track detectors, especially hydrogen nuclei. The energy of the neutron, incident position, direction, and type of interaction were sampled by the Monte Carlo method. The energy threshold, critical angle and scattering angle to the detector surface normal were the most important factors considered in our calculations. The energy deposited per neutron mass unit was calculated. The angular response was determined by both Monte Carlo simulation and experimental results. The number of visible proton tracks and energy deposited per neutron per visible track were calculated and simulated. The threshold energy of the recoil proton as a function of the thickness and incident proton angles was measured by the etchable range of protons at scattering angles, along with the shape and diameter of the track. Experimental and simulations result were in good agreement.

*Key words:*  $^{252}\text{Cf}$  neutron source, nuclear track, CR-39 detector, particle recoil, Monte Carlo simulation

## INTRODUCTION

Applications of solid-state nuclear track detectors (SSNTD) have been reported in various fields of science and technology [1]. These detectors are useful for the registration of heavy charged particles having energies ranging from tens of keV up to several hundreds of MeV [2] although, below 200 keV, a large discrepancy between the latent and etched tracks exists [3]. CR-39 detectors have been successfully utilized for the detection of neutrons and ionized particles [4, 5]. A neutron is an uncharged particle and, therefore, it does not cause ionizations in the detectors; accordingly, it does not produce tracks in SSNTD. Owing to the elastic and inelastic interactions of neutrons with the constituent atoms of the CR-39 detector ( $\text{C}_{12}\text{H}_{18}\text{O}_7$ , consisting of hydrogen, oxygen, and carbon), recoil nuclei with an energy above the threshold

induce latent intrinsic tracks. To determine neutron detector efficiency for latent track formation in a CR-39 (defined as the number of latent tracks created by alpha particles, protons or other recoil particles per incident neutron) [3], it is possible to simulate the energy deposit of protons and alpha particles produced by elastic and nuclear reactions in a CR-39 per incident neutron by changing the input parameters of the MCNP code.

The interaction of neutrons emitted from a  $^{252}\text{Cf}$  source by the CR-39 detector is simulated in this study. Our simulations are based on the critical angle and recoil-energy particle distribution for latent track formation. Furthermore, to verify simulation results, the experiments were carried out using neutrons emitted by a  $^{252}\text{Cf}$  source. In this work, the angular response of the CR-39 detector for detecting fast, neutron-induced recoils, is investigated using MCNP codes and measured experimentally, as well.

\* Corresponding author; e-mail: jschai@skku.edu

## EXPERIMENTS

The experiments were carried out at the detection laboratory of Sungkyunkwan University (SKKU). We have assumed that CR-39 detector sheets (dimension: 2 cm × 2 cm; thickness: 700 μm, density: 1.32 g/cm<sup>3</sup>) are irradiated by an uncovered, cylindrically-shaped <sup>252</sup>Cf neutron source (base diameter: 2.5 cm; height: 3.1 mm). In this study, CR-39 track detectors obtained from Intercast Europe Spa, Parma, Italy, were used. The source-to-detector distance was 5 cm and the neutron flux of the <sup>252</sup>Cf source of the CR-39 detector was 432 cm<sup>-2</sup>s<sup>-1</sup>. Furthermore, it was assumed that neutrons are emitted from the source surface and that interactions within the source itself should be neglected. The irradiations were carried out at angles of 0°, 15°, 30°, 45°, 60°, 75°, and 90° (with respect to the normal to the detector surface, see fig. 1 for details on the experimental set-up at SKKU). The activity of the <sup>252</sup>Cf source was 4570 Bq, with an active diameter per volume of 5 mm, while its backing was platinum and the cover approximately 100 μg Au per cm<sup>2</sup>. This source had a total surface emission rate of 142900 alpha particles per min in 2 on April 21, 2011. A <sup>252</sup>Cf was placed in an aluminum standpipe at the same height as the detector. After irradiations, CR-39 detectors were etched in 6 N sodium hydroxide (NaOH) at 70 °C for 8 hours. Since protons created through both elastic and inelastic reactions were emitted in various directions, their latent tracks were randomly oriented in all directions at the point of interaction, anywhere within the CR-39 detector. Some tracks will be revealed in the direction of the particles' motion, while some others might be etched in a direction opposite to the motion of the particles. There were also instances of tracks due to a partial energy loss of particles in CR-39 detectors (those that leave detector surfaces). Since the interaction of neutrons will take place anywhere within a CR-39, the loss of tracks due to the removal from the detector surface will be compensated by the creation of new tracks in the deeper

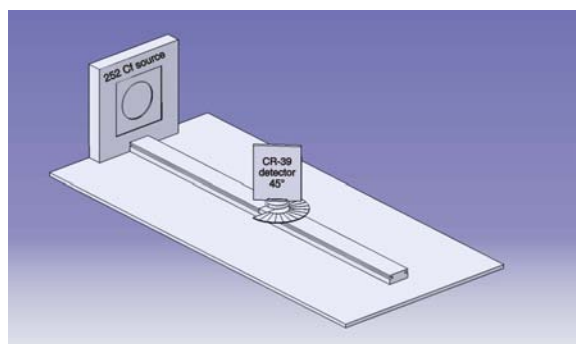

Figure 1. Experimental set-up of the <sup>252</sup>Cf source used at different irradiation angles of CR-39 detectors where the source-to-detector distance is 5 cm and irradiations are carried out at angles of 0°, 15°, 30°, 45°, 60°, 75°, and 90°

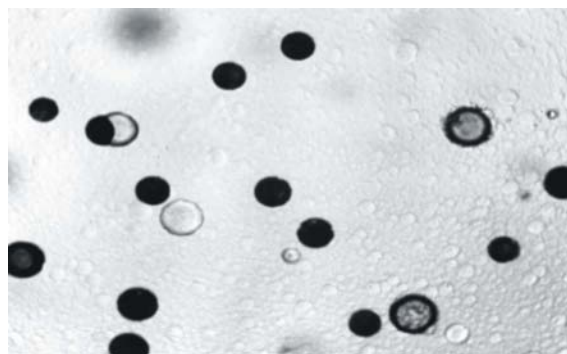

Figure 2. Optical microscopy images of observed tracks from the interaction of neutrons emitted by the <sup>252</sup>Cf source with the CR-39 detector etched in 6 N NaOH for 8 hours

layers of the surface. The method employed to examine these tracks was explained in our previous work [6]. A digital image-analysis system, including a USB camera (2000 × 1500 pixels), a microscope (magnification of about 1000) and image-processing software (track counting system), was applied for track counting. The spatial resolution is 0.9 μm per pixel. By analyzing the shape of the tracks, this analysis system can even distinguish overlapping tracks (fig. 2). Finally, track density and mean track diameter were obtained by a customized program developed by the authors.

In this study, both elastic and inelastic processes are investigated. Fast neutron tracks are produced mainly by using recoil particle tracks in a plastic nuclear track detector, resulting from the elastic scattering reaction of neutrons with the constituent materials of the SSNTD, especially hydrogen nuclei. The threshold energy of recoil protons as a function of CR-39 thicknesses and incident proton angles is measured. To do so, the etchable range of protons within the mentioned scattering angles, along with the shape and diameter of tracks, are essential for the further development of track analysis of the MATLAB program.

## CALCULATION METHOD

Nuclear reactions such as (n, p), (n, α), (n, t), and (n, d), which emit various charged particles, are non-elastic processes. The most intense nuclear reactions are (n, p) and (n, α), whereas others, which have much smaller cross-sections, are neglected in this study. Elastic scattering reactions are more intensive than nuclear reactions; therefore, recoil particle tracks are extremely important. Neutron energy, incident position and direction, as well as the interaction type, are sampled by the Monte Carlo method. The target atom is sampled as follows: if the total cross-sections of the atoms are denoted as  $\sigma_H$ ,  $\sigma_C$ , and  $\sigma_O$ , the total cross-section of a molecule,  $\sigma_{tot}$ , is given by  $\sigma_{tot} = 18\sigma_H + 12\sigma_C + 7\sigma_O$ . The three ratios are defined as

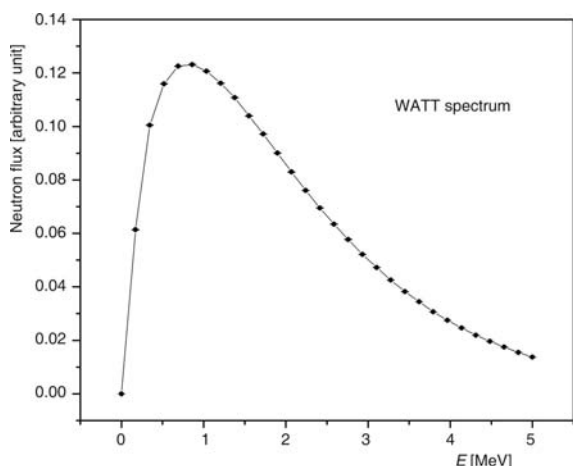

Figure 3. WATT spectrum of the  $^{252}\text{Cf}$  neutron source

$A = 18 \sigma_{\text{H}}/\sigma_{\text{tot}}$ ,  $B = 12 \sigma_{\text{C}}/\sigma_{\text{tot}}$ ,  $C = 7 \sigma_{\text{O}}/\sigma_{\text{tot}}$  [7]. The energy and angle of elastic scattered neutrons and recoiled nuclei are calculated by the well-known method described by Mukhin [8]. The neutron energy spectrum of  $^{252}\text{Cf}$  is well-known to be a fission neutron spectrum and is called the WATT spectrum, while the cross-section data was taken from the ENDF/B-VII library. The WATT spectrum is shown in fig. 3. We have also checked if the recoil proton stays in the detector or not, according to its range [9]. All of the energy is absorbed if the recoil proton is completely stopped in the detector material. It is not necessary to calculate the energy deposited by a proton before leaving the detector. The angles, as well as the energy of a radiated alpha particle and residual nucleus, are calculated for the  $(n, \alpha)$  reaction. Alpha particle energy is equal to neutron energy before collision, plus the  $Q$ -value of the reaction, minus the energy of the residual nucleus. A similar approach is used for another important reaction, namely,  $(n, p)$ . The angles, as well as the energy of the emitted proton and residual nucleus are calculated [7]. The formation of visible tracks is strongly dependent on several factors. The energy threshold, critical angle  $\theta_c$ , and the scattering angle to the detector surface normal being the most important factors considered in our calculations. Recoils with energy below the energy threshold or with a scattering angle above the critical angle do not form revealed tracks. Based on the track mechanism, the critical angle can be defined as a function of the track etch ratio ( $V$ ) which is a ratio of the track etch rate ( $V_T$ ) to the bulk etching rate ( $V_B$ ). The correlation is given as [10]

$$\theta_c = \sin^{-1}(V_B/V_T) \quad (1)$$

For our simulation, we have developed a computer program called the track counting system. The program is written in standard MATLAB codes. It reads saved files such as JPG files and calculates the number of tracks, track density and the mean track diameter. Our program fulfills the prerequisites for read-

ing the number of tracks such as threshold energy, overlapping tracks and background. When two tracks overlap at the same position, our computer program recognizes them as a single track. In cases of low track density with a similar background, this computer program omits these tracks. Owing to the very small proportion of latent alpha tracks (<1%), only carbon, oxygen, and proton recoils are taken into account. By using SRIM codes [9], we can calculate the linear energy transfer (LET) for different energy ranges of recoils. The optimum thickness of the degrader for the registration of 0.5 MeV-4.5 MeV recoil protons resulting from a  $^{252}\text{Cf}$  source in the CR-39 detector is determined by using MCNP and SRIM codes. The track size depends on the damage caused in the CR-39 detector which, in turn, depends on the energy and direction of recoil protons [11]. After reading the number and track sizes, using the MCNP code, we can calculate the angular distribution of the secondary particles. Their latent tracks were examined for their capacity to become revealed tracks. This was done by checking: (1) if their incident angle to the CR-39 detector surface is larger than the critical angle and (2) if the diameter of the track is larger than 1.2  $\mu\text{m}$ . The simulation of neutron interactions through the CR39 detector was performed by the MCNP code. The distributions of recoiled protons were presented in fig. 4 and fig. 5, respectively.

## RESULTS AND DISCUSSION

Our simulation was based on the histories of one million neutrons in a CR-39 detector. The proton energy deposition in the CR-39 detector was  $2.78 \cdot 10^{-2}$  MeV/g per neutron.

Tracks that enter perpendicular to the face produce a circular image, while those entering at an angle produce an elliptical or teardrop-shaped image. Figure 3 shows the long axis track-size distributions of  $^{252}\text{Cf}$

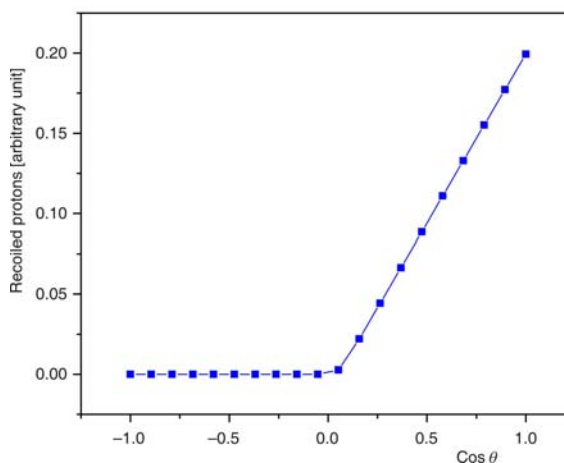

Figure 4. Distributions of recoiled protons vs. angles simulated by MCNPcode

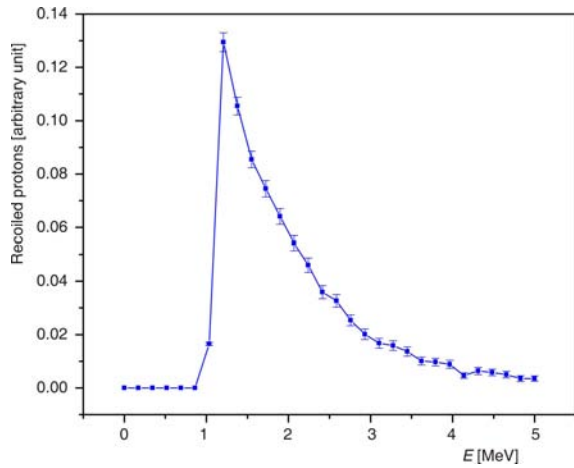

Figure 5. Distributions of recoiled protons vs. energy simulated by MCNP code

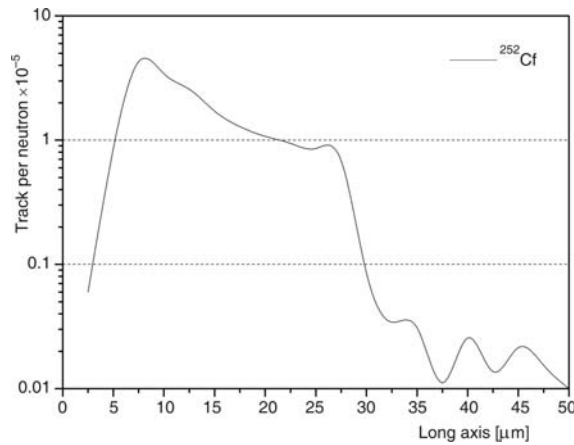

Figure 6. CR-39 track size distribution for a <sup>252</sup>Cf neutron source

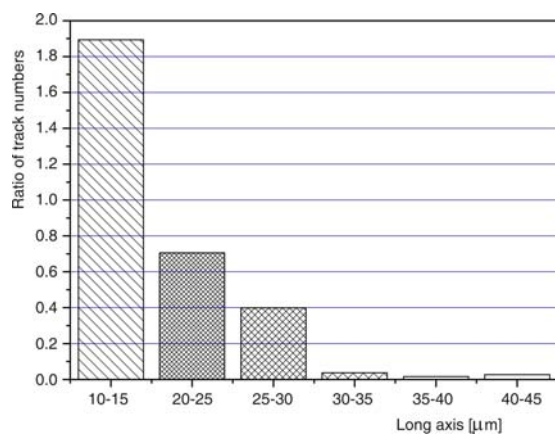

Figure 7. Normalized ratio of the track numbers over long axis

neutrons energies. There were no significant differences between the 0° angle and other angle distributions, so they were combined in fig. 6. The track size depends on both LET along the track and the range.

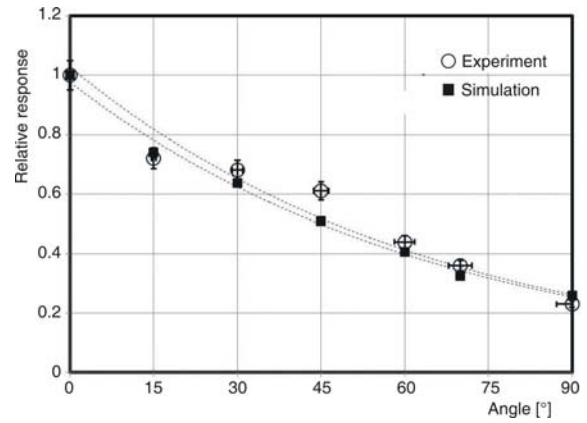

Figure 8. Angular response of CR-39 detector to neutrons emitted by a <sup>252</sup>Cf source

Figure 7 shows the distributions of the ratio of the number of tracks and their long axes between 10-15, 25-30, 30-35, 35-40, and 40-45 μm over 15-20 μm.

Figure 8 shows the curves of the relative angular response obtained in the experiments and simulations for source-to-detector geometry shown in fig. 1. Experimental and simulation results are in good agreement. At large angles, the relative error increases because track densities are lower and the uncertainty in angle determination has a greater contribution. As a result of these uncertainties, the agreement between the simulation and experimental results decreases.

In order to increase the response of CR-39 detectors to neutrons, a CR-39 sheet was used as a radiator in contact with various thicknesses of an Al degrader placed in contact with the CR-39 detector. The results obtained using MCNP and SRIM for the threshold energy of a recoil proton as a function of both CR-39 radiator thickness and incident proton angles are shown in fig. 9. At a small angle, the threshold energy of the recoil proton increases with thickness.

In our experiment, the limitation of the track diameter for counting was 1.2 μm, while track densities were in the range of 2000 to 8000 tracks per cm<sup>2</sup>. In the case of fig. 2, track density was 3930 track per cm<sup>2</sup>.

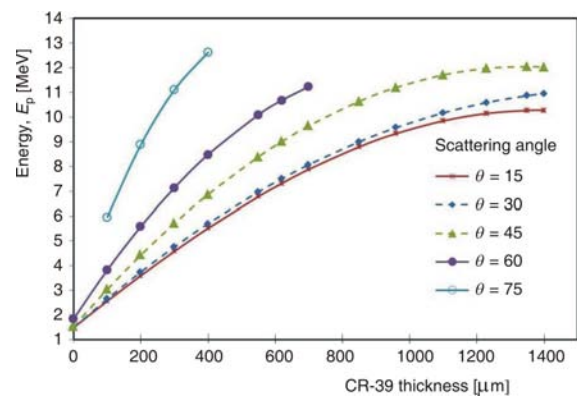
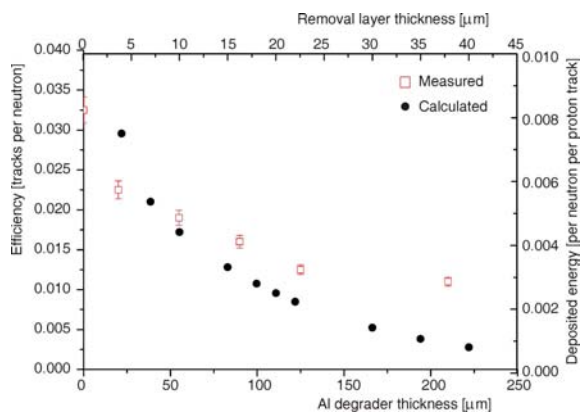

Figure 9. Threshold proton energy as a function of CR-39 radiator thickness and scattering angles



**Figure 10. Track efficiency and deposited energy per neutron (responses) in the CR-39 detector obtained by both the experiment and the simulations**

This was achieved by using our MATLAB program and subsequently improved by another developed program called ATMS [12]. The rate of proton registration in the detector was determined from both the polynomial curve fit to fig. 9 and the PTRAC card of the MCNP code. Therefore, through this simulation, one can easily obtain the recoil proton specification from the output PTRAC card of the MCNP, tracks of recoil protons in different layers of the CR-39 radiator and the registration rate (efficiency) of the CR-39 detector.

By placing various thicknesses of an Al degrader (ranging from 0 to 250 μm) between the CR-39 degrader and the CR-39 detector, proton threshold energies of 0.5 to 4.5 MeV were covered. After the irradiation of the radiator, degrader, and detector assemblies by neutrons, the etched tracks were counted. Figure 10 shows the efficiency of proton registration tracks (left side of axis Y) vs. Al degrader thicknesses and the simulation of the deposited energy per neutron – per visible proton track (right side of axis Y) – vs. the removal layers of CR-39.

Tracks and the energy deposited by the alpha particles are neglected, because the probability of the creation of alpha particles by them is much smaller than the one related to protons. The number of revealed tracks decreases with each removal layer. As a result of the fitting to the data in fig. 7, the following equation was obtained

$$Y = ae^{bX} + ce^{dX} \quad (2)$$

where,  $Y$  is the efficiency, visible proton track per neutron,  $X$  – the removal layer, and the coefficients are  $a = 0.2355$ ,  $b = -0.7193$ ,  $c = 0.07741$ , and  $d = -0.05651$ .

The relative statistical error for track counting depends on the track densities of the sample and it varies from 7 to 10%.

## CONCLUSIONS

A simulation of neutrons emitted from a  $^{252}\text{Cf}$  source and their interaction with a CR-39 detector was presented in this paper. We developed a customized program to count the number of visible tracks. MCNP and SRIM codes were used to calculate recoil protons and the angular response of the CR-39 detector to neutrons emitted by a  $^{252}\text{Cf}$  source. The polynomial curve fitting shows the usefulness of the threshold energy of the protons registered at different thicknesses of the CR-39 detector and different directions. The rate of proton registration in the detector was determined from the polynomial curve fit to threshold proton energies with the removal thickness of the CR-39 detector at different scattering angles and from the MCNP PTRAC card, by simulating the recoil proton specification and tracking of recoil protons in different layers, the registration rate of the CR-39 detector can easily be obtained. As indicated in fig. 10, the deposited energy per one neutron as a function of the removal layer of CR-39 predicts a trend similar to the proton registration rate (tracks per neutron) with variations in degrader thickness. These results were also verified experimentally.

## ACKNOWLEDGMENT

This research was supported by the IT R&D program of Ministry Knowledge Economy (MKE) through the National Research Foundation of Korea funded by the KEIT (R 10043897).

## AUTHOR CONTRIBUTIONS

Theoretical analysis was carried out by M. Ghergherehchi, H. Afarideh, and Y. S. Kim and experiments were carried out by M. Ghergherehchi and J. S. Chai. The manuscript was written by Y. S. Kim and M. Ghergherehchi and the figures were prepared by M. Ghergherehchi and H. W. Kim.

## REFERENCES

- [1] Durrani, S. A., Nuclear Tracks: A Success Story of the 20<sup>th</sup> Century, *Radiat. Meas.*, 34 (2001), 1-6, pp. 5-13
- [2] Qindeela, R., *et al.*, Detection and Investigation of Carbon Ions Induced by Nd: YAG Laser Using SSNTD, Enabling Science and Nanotechnology, *AIP Conf. Proc.*, 1341 (2012), pp. 205-209
- [3] Khan, R. F. H., Ahmad, N., Aslam, M., Studying the Response of CR-39 Detectors Using the Monte Carlo Technique, *Radiat. Meas.*, 33 (2001), 1, pp. 129-137
- [4] Fleisher, R. L., Price, B. P., Walker, R. M., Nuclear Tracks in Solids, University of California Press, Berkeley and Los Angeles, 1975, p. 627

- [5] Palfalvi, J., Balasko, M., Sajo-Bohus, L., Realistic Neutron Spectra for Radiation Protection and other Applications at AERI, Budapest, *Nucl. Instrum. Meth. A.*, 476 (2002), pp. 452-456
- [6] Ghergherehchi, M., *et al.*, Dosimetry and Microdosimetry of 10-220 MeV Proton Beams with CR-39 and their Verifications by Calculation of Reaction Cross-Sections Using ALICE, TALYS and GEANT4 Codes, *Radiat. Meas.*, 47 (2012), 6, pp. 410-416
- [7] Milenković, B., Nikezić, D., Stevanović, N., A Simulation of Neutron Interaction from Am-Be Source with the CR-39 Detector, *Radiat. Meas.*, 45 (2010), 10, pp.1338-1341
- [8] Mukhin, K. N., Experimental Nuclear Physics, in: Physics of Atomic Nucleus, Vol. I. Mir Publishers, Moscow, 1987
- [9] Ziegler, J. F., Biersack, J. P., Ziegler, M. D., The Stopping and Range of Ions in Matter, SRIM Co., Chester, Md., USA, 1985, <http://www.Srim.org>
- [10] Durrani, S. A., Bull, R. K., Solid State Nuclear Track Detection. Pergamon Books Ltd, Oxford, UK, 1987, pp. 27-33
- [11] Doerschel, B., Hermsdorf, D., Kadner, K., Determination of the Critical Angle of Track Registration in Proton Irradiated and Chemically Etched CR-39 Detectors, *Radiat. Prot. Dosim.*, 71 (1997), 4, pp. 245-250
- [12] Khayat, O., *et al.*, ATMS Software: Fuzzy Hough Transform in a Hybrid Algorithm for Counting the Overlapped Etched Tracks and Orientation Recognition, *Radiat. Meas.*, 50 (2012), pp. 1-4

Received on January 1, 2013

Accepted on June 11, 2013

**Митра ГЕРГЕРЕЧИ, Хјун Вук КИМ, Јун Санг КИМ, Хосеин АФАРИДЕХ, Јонг Сео КАИ**

**УПОРЕДНА СТУДИЈА ЕКСПЕРИМЕНТАЛНИХ И СИМУЛИРАНИХ  
ОДГОВОРА ДЕТЕКТОРА CR-39 НА НЕУТРОНСКИ СПЕКТАР  $^{252}\text{Cf}$**

У овом раду приказана је симулација интеракције неутрона емитованих из извора  $^{252}\text{Cf}$  са детектором CR-39, то јест, еластична и нееластична интеракција неутрона на градивним материјалима овог детектора. У нееластична расејања укључене су само (n,  $\alpha$ ) и (n, p) реакције. Путање брзих неутрона углавном сачињавају путање узмаклих честица у пластичном нуклеарном детектору трагова, као резултат еластичног расејања неутрона на градивном материјалу детектора, нарочито на језгрима водоника. Енергија неутрона, упадни положај, правац и врста интеракције симулирани су Монте Карло методом. Најважнији фактори разматрани у прорачунима су енергетски праг, критични угао и угао расејања у односу на нормалу на површину детектора. Израчуната је енергија депонована по јединици масе неутрона, а Монте Карло симулацијом и експериментално одређена је угаона зависност одзива. Број видљивих путања протона и енергија депонована по неутрону по видљивој путањи, такође су израчунати и симулирани. Енергетски праг узмаклог протона у функцији дебљине материјала и упадних углова протона мерен је помоћу домета протона добијеног у нагриженом материјалу по угловима расејања, заједно са обликом и пречником путање. Експериментални резултати и резултати симулације добро се поклапају.

*Кључне речи:*  $^{252}\text{Cf}$  неутронски извор, нуклеарна пуцања, CR-39 детектор, узмак честице, Монте Карло симулација