

**IMPLEMENTATION OF A WEARABLE GAS SENSOR NETWORK
FOR OIL AND GAS INDUSTRY WORKERS**

BY

ADEL MOHAMMED SOLAIMAN BINAJJAJ

A Thesis Presented to the
DEANSHIP OF GRADUATE STUDIES

KING FAHD UNIVERSITY OF PETROLEUM & MINERALS

DHAHRAN, SAUDI ARABIA

In Partial Fulfillment of the
Requirements for the Degree of

MASTER OF SCIENCE

In

COMPUTER ENGINEERING

April 2016

KING FAHD UNIVERSITY OF PETROLEUM & MINERALS

DHAHRAN- 31261, SAUDI ARABIA

DEANSHIP OF GRADUATE STUDIES

This thesis, written by **ADEL MOHAMMED SOLAIMAN BINAJJAJ** under the direction his thesis advisor and approved by his thesis committee, has been presented and accepted by the Dean of Graduate Studies, in partial fulfillment of the requirements for the degree of **MASTER OF SCIENCE IN COMPUTER ENGINEERING**.

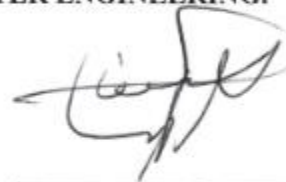



Dr. Tarek Rahil Sheltami
(Advisor)



Dr. Yahya Ismail Osais
(Member)



Dr. Ahmad Al-Mulhem
Department Chairman



Dr. Salam A. Zummo
Dean of Graduate Studies



Dr. Muhammad Y. Mahmoud
(Member)

23/5/16
Date

© Adel Mohammed Binajjaj

2016

*To my late father, my mother,
my brothers and my sisters*

ACKNOWLEDGMENTS

In the name of Allah, Most Gracious. All praise is to Almighty Allah who gave me courage, knowledge and ability to complete this work and blessing of Allah be upon his prophet Mohammed (peace be upon him).

I wish to express my deep appreciation and thanks to Dr. Tarek Rahil Sheltami, thesis advisor, and Dr. Yahya Ismail Osais, and Dr. Muhammad Y. Mahmoud, committee members, for their guidance and professional advice without which the success of this project cannot be possible. I would also like to show my appreciation to Mr. Farouq Muhammed Aliyu and Mr. Yau Garba whose advice led to the project itself.

Acknowledgment is due to King Fahd University of Petroleum & Minerals. My sincere appreciation is extended to all faculty and staff of the Computer Engineering Department for their contribution to this work. Finally, I would like to thank Kingdom of Saudi Arabia, Hadhramaut Establishment for Human Development (HEHD), family, friends and all well-wishers for their support and encouragement, which serve as a driving force for this research and my study at large.

TABLE OF CONTENTS

ACKNOWLEDGMENTS.....	V
TABLE OF CONTENTS	VI
LIST OF TABLES.....	IX
LIST OF FIGURES.....	X
LIST OF ABBREVIATIONS.....	XII
ABSTRACT.....	XIII
ملخص الرسالة.....	XIV
CHAPTER 1 INTRODUCTION.....	1
1.1 MOTIVATION.....	2
1.1.1 The effects of air pollution on human health	2
1.1.2 Monitoring air pollutants	3
1.1.3 Oil and gas fields safety	4
1.2 OBJECTIVES:	5
1.3 CONTRIBUTION OF THE RESEARCH	5
1.4 THESIS ORGANIZATION	6
CHAPTER 2.....	7
2.1 INTRODUCTION	7
2.2 LITERATURE REVIEW	8

CHAPTER 3 WEARABLE GAS SENSOR NETWORK13

3.1 INTRODUCTION 13

3.2 REQUIREMENTS FOR IMPLEMENTATION OF WEARABLE SYSTEM..... 13

3.3 WIRELESS COMMUNICATION TECHNOLOGIES 14

 3.3.1 ZigBee..... 15

 3.3.2 WirelessHART..... 16

 3.3.3 ISA100.11.a 16

3.4 INDUSTRIAL GASES AND THEIR PROPERTIES 18

 3.4.1 Carbone monoxide (CO)..... 18

 3.4.2 Methane (CH₄)..... 20

3.5 TOXIC AND COMBUSTIBLE GASES SENSORS 21

 3.5.1 Metal oxide sensors..... 23

CHAPTER 4 SYSTEM ARCHITECTURE27

4.1 INTRODUCTION 27

4.2 SYSTEM HARDWARE DESIGN 27

 4.2.1 Arduino Mega 2560 28

 4.2.2 Xbee communication module 31

 4.2.3 GPS module 37

 4.2.4 Accelerometer 38

 4.2.5 Gas sensor 38

4.3 SYSTEM SOFTWARE DESIGN 41

 4.3.1 Sensor node software 41

4.3.2	Coordinator software	43
4.4	ROUTER NODE.....	44
CHAPTER 5 RESULTS AND CONCLUSION		46
5.1	INTRODUCTION:	46
5.2	SYSTEM EXPERIMENT	46
5.2.1	Calibrating MQ-7:.....	47
5.2.2	System test	49
5.3	POWER CONSUMPTION	54
CHAPTER 6 CONCLUSION.....		60
6.1	CONCLUSION.....	60
6.2	FUTURE WORK	61
REFERENCES		62
VITAE.....		73

LIST OF TABLES

Table 1 Application of wireless sensors	2
Table 2 Industrial Wireless standard comparison.....	17
Table 3 Carbone Monoxide Effectes	19
Table 4 Comarison of sensing technology.....	26

LIST OF FIGURES

Figure 1 Toxic gas detection network.....	3
Figure 2 ZigBee Network	15
Figure 3 Semiconductor gas sensitive.....	24
Figure 4 Toxic and combustible gas sensor.....	25
Figure 5 designed end node	27
Figure 6 ARDUINO MEGA 2560.....	28
Figure 7 Arduino Mega 2560 schematic.....	30
Figure 8 XBee PRO S2B Module.....	31
Figure 9 Data flow diagram in UART	32
Figure 10 AODV route request and route reply mechanism	33
Figure 11 Coordinator settings.....	34
Figure 12 Network working mode.....	34
Figure 13 XBee Shield.....	35
Figure 14 XBee shield schematic	36
Figure 15 GPS module and GPS shield on top of arduino	37
Figure 16 MPU-6050 motion detector module.....	38
Figure 17 Gas sensor board.....	39
Figure 18 MQ-7 sensor	39
Figure 19 Sensor board	39
Figure 20 Circuit diagram of gas sensor board.....	40
Figure 21 Flowchart of sensor node software.....	42
Figure 22 API packet format.....	43

Figure 23 coordinator flowchart	45
Figure 24 CO concentration in part per million.....	48
Figure 25 CH4 concentration in part per million.....	48
Figure 26 CH4 concentration results	49
Figure 27 CO concentration results	50
Figure 28 Signal strength at distance of 35 meter.....	51
Figure 29 Signal strength at distance of 70 meter.....	51
Figure 30 GPS data	52
Figure 31 CH4 concentration when it was applied to the sensor.....	53
Figure 32 CO concentration when CH4 was applied to the sensor	53
Figure 33 Signal strength between router node and coordinator	54
Figure 34 GPS data	54
Figure 35 Experiment setup of end node power consumption	55
Figure 36 Arduino power consumption in sleep and wake modes	56
Figure 37 Xbee module power consumption in listening and transmitting mode	57
Figure 38 GPS module power consumption	57
Figure 39 MQ-7 power consumption in low heating and high heating voltage	58
Figure 40 Accelerometer power consumption.....	58
Figure 41 wake up state of all components of sensor node	59

LIST OF ABBREVIATIONS

WSN	:	Wireless Sensor Network
LED	:	Light Emitting Diode
MOS	:	Metal Oxide Semiconductor
GPS	:	Global Positioning System
ADC	:	Analog to Digital Converter
PCB	:	Printed Circuit Board
CO	:	Carbone monoxide
CH4	:	Methane
VOC	:	Volatile Organic Compounds
PPM	:	Part Per Million
UART	:	Universal Asynchronous Receiver/Transmitter
AODV	:	Ad hoc On-demand Distance Victor

ABSTRACT

Full Name : Adel Mohammed Solaiman Binajjaj

Thesis Title : Implementation Of A Wearable Gas Sensor Network For Oil And Gas Industry Workers.

Major Field : Computer Engineering

Date of Degree : May, 2016

Industrial environment usually involves some types of hazardous substances including toxic and/or flammable gases. Accidental gas leakage can cause potential dangers to a plant, its employees and surrounding neighborhoods. Around 64% of accidents that happen in the oil fields are due to combustibles and/or toxic gases [1]. The safety plan of most industries includes measures to reduce risk to humans and plants by incorporating early-warning devices, such as gas detectors [2]. Most existing tools for monitoring gases are stationary and incapable of accurately measuring individual exposures that depend on personal lifestyles and environment. This proposal provides a design and implementation of a wearable gas sensor network by building sensor nodes with wireless communication modules which communicate their data along the network. The system is designed to be flexible, low cost, low maintenance and with accurate performance to detect toxic gases in a timely fashion to warn employees before an existence of a disaster.

ملخص الرسالة

الاسم الكامل : عادل محمد سليمان بن عجاج.

عنوان الرسالة : تنفيذ شبكة حساسات الغازات والقابلة للارتداء للعاملين في صناعة النفط والغاز .

التخصص : هندسة حاسب آلي.

تاريخ الدرجة العلمية: : أبريل 2016م.

تحتوي البيئة الصناعية على انواع من المواد الخطيرة والتي تتضمن الغازات السامة والغازات القابلة للاشتعال. تسرب الغاز في مثل هذه البيئة يسبب خطر محتمل للعاملين او المصنع نفسه او البيئة المحيطة. تقدر نسبة الحوادث الناتجة عن الغازات السامة والقابلة للاشتعال في صناعات البترول بحوالي 64%. خطط السلامة في معظم الصناعات تتلخص في تقليل الخطر على الاشخاص والمصانع بواسطة اجهزة تحذير استباقية مثل مستكشفات الغازات. ولكن معظم هذه الاجهزة تكون ثابتة ولا تعطي قياسات دقيقة لبيئة المحيطة بالشخص والقريبة منه. لذلك قمنا في هذه الرسالة وهذا البحث بتقديم تصميم وعمل جهاز قابل للارتداء يقوم بكشف الغازات السامة والقابلة للاشتعال وعمل شبكة في مابين هذه الاجهزة باستخدام جهاز متحكم ووحدة اتصال لاسلكي و مستشعر. النظام هذا سيكون له عدة خصائص مثل المرونة وقلة الكلفة وقلة الصيانة وقابلية التوسيع والاداء لاكتشاف الغازات السامة في وقت معقول قبل حدوث اي كارثة.

CHAPTER 1

INTRODUCTION

Currently wireless sensor networks (WSNs) are being used in different applications shown in Table 1. They have various features, such as low cost, low power consumption, reduced maintenance time, improved tools performance and enhanced safety which make it a feasible solution for many industries. For instance, The oil and gas industry includes processes for exploration, extraction, refining, transporting, and marketing petroleum products [3] and this can also be found in the steel, aluminum, mineral, automotive, medical, agricultural, aroma and food industries. Wireless gas sensors usually have limited resources, such as processing unit, power supply unit, storage. However, when they work together to do a specific task, they accomplish an accurate description of the physical phenomena that we need to measure.

The property of wireless technology allows the sensor network to be deployed in a harsh environment or in a place where the wired network is difficult or impossible to be deployed or in unreachable area [4].

Enhancing the use of this technology can be done through three methods: mathematical methods, simulations method and/or real-time experiments. In this research a real-time experiment is conducted in order to come up with a prototype to be used for monitoring toxic gases in oil and gas industries.

Table 1 Different applications used wireless sensor network

Applications	
Automobiles	<ul style="list-style-type: none">▪ Car ventilation control▪ Filter control▪ Gasoline vapor detection▪ Alcohol breath tests
Safety	<ul style="list-style-type: none">▪ Fire detection▪ Leak detection▪ Toxic/flammable/explosive gas detectors▪ Boiler control▪ Personal gas monitor
Indoor air quality	<ul style="list-style-type: none">▪ Air purifiers▪ Ventilation control▪ Cooking control
Environmental control	<ul style="list-style-type: none">▪ Weather stations▪ Pollution monitoring
Food	<ul style="list-style-type: none">▪ Food quality control▪ Process control▪ Packaging quality control (off-odors)
Industrial production	<ul style="list-style-type: none">▪ Fermentation control▪ Process control
Medicine	<ul style="list-style-type: none">▪ Breath analysis▪ Disease detection

1.1 Motivation

1.1.1 The effects of air pollution on human health

Airborne pollutants are known to threaten human health and safety, causing discomfort, illness, and even death, particularly among susceptible individuals, such as those with pre-existing cardiovascular or respiratory problems as well as infants and the elderly [5][6]. Exposure to air pollutants including toxic gases consistently ranks among the leading causes of illness and mortality. Such proof is found in the number of poisonings which occur due to the inhalation of certain gases and aerosols in the air we breathe [7]. In all of these instances the air acts as a medium that allows, and may even assist, the conveyance of the noxious agent from its source to the human host. There is

less agreement among health authorities on the significance of the relationship of gases and aerosols in terms of disease, except when these substances appear in the air of workplaces, or when cases of patent gas poisoning occur.

The air we breathe has not only life-supporting properties, but also potential life-damaging properties. Under ideal conditions, the air that we must inhale has a qualitative and quantitative balance that maintains the well-being of man [7]. When the balance among the air components is disturbed, an individual's health may be adversely affected, the kind of injury sustained and its degree being dependent upon the nature of the disturbance.

1.1.2 Monitoring air pollutants

There is a lack of research conducted in monitoring toxic gases in oil and gas industries using wireless sensor networks. The already existing research focuses on either static sensors [8] or portable devices [9]. It is suggested that a wearable gas sensor network would be a suitable technology to be employed in such industries; however the design of a wearable gas sensor should be easy to use, comfortable, and small.

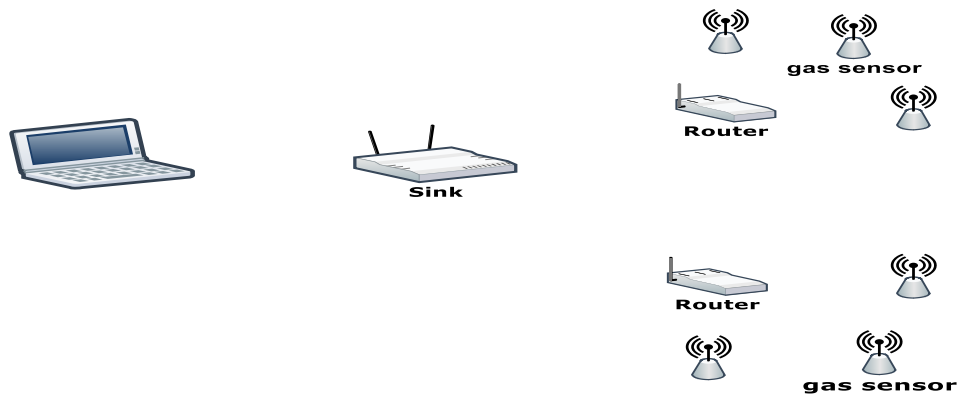

Figure 1 Toxic gas detection network

1.1.3 Oil and gas fields safety

Crude oil is formed as a result of accumulation of animals and plants that died millions of years ago and fell to the bottom of the sea. These remains were covered by mud, which eventually became rock, thus forming a seal. The rock exerts pressure on the dead animals and plants, thereby generating heat between 60-120⁰ C [10]. Together, the heat and the pressure in the absence of oxygen turned the remains into crude oil. However, if the trapped organic matter is heated to temperatures greater than 120⁰ C gases are formed [11] which are either toxic or combustible [12]. As a result of this process, many accidents have occurred in several industry fields, one notable example is the, ExxonMobil fire incident on 18th February 2015 in Torrance, California [13]. In this incident, a massive explosion took place in ExxonMobil oil refinery, which injured four workers and led to considerable damage to the refinery. The incident happened while a maintenance worker was doing his job making an ignition near a leakage of gas. Another gas related accident took place on April 20th, 2010 in the Gulf of Mexico. In this incident, eleven workers died and several others were injured due to a blowout as a result of several "kicks" on the Deepwater Horizon oil rig [14]. A kick is a sudden and unplanned release of well fluids (especially gases) into a wellbore [15]. It was found that these accidents were either due to the total absence of gas sensors in operation sites or the lack of their continuous presence (throughout the time of operation) in the area [16]. In an effort to avoid such accidents, safety measures to curbe the risk of gas related accidents have been recommended by United States Chemical Safety Board (USCSB) [17] and regulations are passed by Occupational Safety and Health Administration (OSHA) [18].

1.2 Objectives:

The goal of this research is to find an efficient wearable sensor network for monitoring toxic and combustible gases that cause a serious risk to both human beings and the environment. A number of objectives are listed as follows:

- Implementation of a wearable gas sensor network using gas sensors, Arduino microcontroller, and XBee wireless communication module.
- Early warning messages to be sent to workers for toxic gases before it reaches its low danger level.
- Developing a system that can be able to pinpoint a missing worker.
- The system provides many features: flexibility, cost effectiveness, and low maintenance.

1.3 Contribution of the research

- A wearable sensor network with wireless communication can accurately measure toxic and combustible gas around individuals and send warning messages to other workers.
- A modified version of MQ-7 sensor to sense Carbon Monoxide (CO) and methane (CH₄) instead of CO only, depends on the sensitivity characteristics of the sensor.
- An innovative method to reduce the power consumption of the sensor node by using accelerometer and on demand switching on/off the GPS, communication module and sensor.

1.4 Thesis organization

Chapter 2 describes literature review of state-of-the-art gas detection systems that other researchers have developed. Chapter 3 provides the requirements for implementation of a wearable system and wireless communication technologies which are used in oil and gas industries. We also cover the industrial gases and sensors types that are suitable for detecting toxic gases. Chapter 4 outlines overall system architecture and the system hardware and software design. In chapter 5, explanation of experiment setup and results are presented. Chapter 6 gives a summary of the entire thesis work and potential for future development respectively.

CHAPTER 2

LITERATURE REVIEW

2.1 Introduction

Recently, there has been a common trend in implementing sensors in order to improve environment safety and control of gases [19]. Engineers prefer wired systems to Wireless Gas Sensor Network (WGSN) [20] due to the fact that they are reliable and they can provide abundant resources, such as energy and bandwidth. However, wired systems have some drawbacks, most notable that their installation is costly in terms of time, money and manpower (all of which are not taken for granted in the Oil and Gas Industry). Also, during relocation (e.g. in oil exploration), a huge man-power is needed to remove and transport the system to a new location, where it will have to be installed again and finally, wired methods are impractical in some applications. Recent development in wireless technology have allowed for the reliable use of wireless communication in the noisy industrial environment. Zigbee (IEEE 802.15.4) is one such developments certified for industrial sensing and diagnostic applications [21]. This paves the way for different kind of WGSN applications.

In this chapter, state of the art designs and research breakthroughs of other researchers in the WGSN are analyzed, in the hope of finding a perfect WGSN solution that complies with industrial standards.

2.2 Literature review

For the current growth in ubiquitous computing and communication, wearable sensors technologies are getting more attention and more research [22][23] has been done in such fields like healthcare [24], safety [25], and environment [26]. As a result, wearable sensors can assist to save human lives [27] and monitor environmental issues. Forsyth et al [28] proposed a wearable system, which can be attached to helmet, to protect a construction worker from carbon monoxide poisoning. The sensor design consists of an Xpod oximeter, an Xbee communication module, and a battery as a power supply. As the power supply is 9V and the Xbee module operates at 3.3V, the system contains an Xbee explorer. The system uses simplex method of transmission (from the Xpod module to the Xbee coordinator receiver), which means users have limited or no control over it. Also, the measurement was affected by the movement of the sensor so that the results sometime are not accurate.

Nikzad *et al* [29] presented a wearable devices (CitiSense) that functions as an air quality sensing system. It communicates with smart phone via Bluetooth to display the most recent air quality measurements and communicates with a web server to allow users to reflect on their overall exposure to pollutants [30]. Similarly Fletcher *et al* [31] developed a device (Eco-Mini) to sample and record variety of environmental parameters (Ozone, Sulfur Dioxide, Volatile Organic Compounds, humidity, temperature, ambient light color balance, and sound level). The device contains Atmel Xmega 128K with (12-bit ADC) and SPI/I2C ports to communicate with sensors. Also 3-axis accelerometer was used to indicate that the Eco-Mini devise was worn and also for more accurate estimation for air pollution exposure. A global position system (GPS) was deployed to determine the

location with an external circuit to reduce power consumption. In addition, to collect data, a Bluetooth module was used to send measured data to mobile phone or stored into SD card for data logging. Moreover, a mobile application was developed to provide simultaneous data on the mobile phone via Bluetooth and a web server for further processing and to display previously collected data. Hu *et al* [32] developed a mobile application that exploits the air pollution data which comes from wearable sensors and human activity energy to estimate the personal inhalation dosage of air pollution.

Heurtefeux *et al* [33] designed a system for monitoring workers who work in harsh environments. Shimmer's [34] wearable device was used as a sensor node to monitor the state of wearer, and the gateway constructed of many devices like beagle board XM [35], touch screen, wireless communication module (WiFi 802.11 and Zigbee 802.15.4). The sink (network coordinator) has a large data storage which allows it to be able to collect data from different workers. Again Wang *et al* [36] developed a portable device that can be used to monitor electricity workers. The device contains pulse and temperature sensors with Zigbee module and 8-bit ATmega128L microcontroller. The system does not have relay nodes and a front-end amplifier RFX2401C was added in order to increase the transmission range of the Zigbee module. However, this amplifier consumes a lot of energy which could affect the life time of the sensor which was not mentioned.

In [37] Senyureket *al* were concerned with increasing the safety of workers who worked alone through a wearable transceiver including movement sensor. The system operates when there is no movement or excessive activity. A ZigBee network was used and it consists of the following: a wearable device that is constructed of accelerometer (MEMS) integrated with digital output, MSP430F2618 Microcontroller to monitor the

wearable sensor component, Zigbee wireless communication module, LEDs, buzzer, and vibrator. Second is the relay node or router, which is responsible for extending transmission range between the wearable sensor and network coordinator by relaying traffic between the two. The third is the gateway device which serves as a bridge between the Zigbee network and a workstation and oversees the operation of the network. As the sensor comprises of only a movement sensor, it will be susceptible to give false alarms. In order to increase the accuracy of the system, many sensors should be added to indicate the exact situation of the worker and the surrounding environment

Air pollution is considered to be one of the important parameters that affects the ecosystem as well as impacts on human health. A variety of methods have been conducted to monitor harmful gases into atmosphere. For example Manes *et al* [38] developed a wireless sensor network for volatile organic compounds (VOCs) detection. The network has many coordinator nodes equipped with climate sensors like temperature, humidity, wind direction and speed, solar radiation, and a rain gauge. Also the network has end devices equipped with VOCs detection sensors distributed in well-identified locations within the plant. The coordinator forwards the data of VOCs sensors and climate sensor to a remote web server for further processing through Ultra High frequency (UHF-ISM) and GSM module for internet connection. However, Photoionization Detectors consumes a large amount of power, so that it will be difficult to replace batteries or using another power supply for the end nodes in a harsh environment. The authors tackled this problem by using a hybrid communication of wire and wireless where the VOCs detector were placed in a dangerous area and the power supply was located in a safe zone [39]. Mead *et al* [40] developed a system with static

and wearable end devices to measure carbon monoxide (CO), nitric oxide (NO), and nitrogen dioxide (NO₂) in air. The sensor node is autonomous and incorporating with gas sensors, GPRS for communication and GPS module. The wearable sensors were designed to be lightweight and convenient to wear whereas the static sensors are more powerful with larger gas sensors, long battery life, temperature, and humidity sensors being added. The disadvantage of the previous system is that each node works autonomously and for this reason Khaled Hossain *et al* [41] enhanced the system by developing nodes which can communicate with each other for long-term measurements of the global warming increase. Each node consists of sensors (temperature, humidity, CO₂), atmega8 microcontroller, clock module to provide time stamp for each reading, and SD card for local storage of data logging. Arduino Uno microcontroller was used in the receiver node with GSM module. Arduino Uno microcontroller [42] is a board based on ATmega328, 16 digital input and output pins, 6 analog input pins, operate at 5V, and the limits input voltage 6-20V.

Similarly Manna *et al* [43] are concerned with monitoring vehicles which cause air pollution using Arduino equipped with gas sensor and RFID readers where RFID tags were attached on each vehicle. Whenever the gas sensor detector sensed a rise in air pollution, the search will begin to identify the vehicle which has caused the pollution. In addition Metkar *et al* [44] proposed a toxic gases monitoring system using windows application and web based technology. This system contains hardware components, such as MQ-6 sensor [45] to measure the existence of toxic gases that emitted from industry plants. The microcontroller collects the data coming from the MQ-6 sensor and compares it with the threshold of toxic gases in order to trigger the actuator circuit which

is used to switch off the electricity of the plant. A Graphic User Interface (GUI) was developed for the system using VB.NET to dial with the receiving data from the sensor nodes.

CHAPTER 3

WEARABLE GAS SENSOR NETWORK

3.1 Introduction

Wearable sensors can be considered one of the latest technologies for researchers and are becoming more and more popular. . A wearable device is basically a small computer which contains sensors, a processing unit, a communication module, and storage [46]. One of the main reasons for rapid developments in this technology is the high demand in military operational use. This has led to transferring this knowledge to use the wearable technology in other fields, such as health, safety, and environmental monitoring [47]. Wireless sensor networks are applied in many aspects of oil and gas industry. They are applied in tracking products and vehicles in the form of Radio-Frequency Identification (RFID) systems. Many reports show how WSN can be used in environmental sensing in order to prevent the loss of oil production at an offshore facility. It is also applied in monitoring applications and the maintenance of machines.

3.2 Requirements for implementation of wearable system

Implementation of any new technology must have a low error or failure rate. Any failure in the oil and gas industry can cause a massive catastrophe to the workers, the company, or the environment. To validate a wearable sensor network in the oil and gas industry [48], the system should meet the following criteria:

- Sensitive to the toxic and combustible gases (such as Methane, Carbon monoxide, Volatile Organic Compound (VOC) in reasonable time.
- Low power consumption and long battery life powered for days or even months.
- The network should be capable to co-exist with other wireless networks or systems in the field.
- The sensor should be small in size and light weight to be more comfortable for wearer.
- The sensor should be low cost, in order to be widely deployed.
- The performance should be satisfactory.

3.3 Wireless Communication Technologies

It is necessary to choose an appropriate wireless network standard protocol because each wireless standard has its own network layers called network stack, physical layer (PHY), Medium Access layer (MAC), Network layer (NWT), Transport layer, and application layer. Some of these standards are not suitable for industrial purposes, for example IEEE 802.11 [49] is designed for a wireless local area network, IEEE 802.15.1 [50] and Bluetooth is compatible with a Wireless Personal Area Network. The IEEE 802.15.4 [51] is the widely accepted standard for the physical (PHY) and Medium access (MAC) layer for WPAN used in sensing, monitoring and control systems. Currently, there are standards developed for industry wireless sensor network, for example ZigBee, wirelessHART [52], and ISA100 [53].

3.3.1 ZigBee

ZigBee is a standard published by ZigBee Alliance in 2001. Its implementation has both application and network as well as application layers on top of the MAC and a PHY layer specified by IEEE 802.15.4. ZigBee is basically designed for low data rate and short range communication. It operates in the ISM band (i.e. 2.4GHz), 868MHz and 915MHz in Europe and America respectively with 250 Kbps. It has a discovery and pairing mechanism and allows star and mesh topology. It also utilize AES-128 security scheme.

ZigBee consist of three types of devices in the application layer; Coordinator, Router and End Node. The first is a Full Function Device FFD while the remaining are Reduced Function Devices RFDs. There should be one coordinator in a network which is responsible for the initiating, securing and managing of the network. Coordinators are not allowed to go to sleep. While the idea of using only one coordinator provides centralization, it also provides single point of failure.

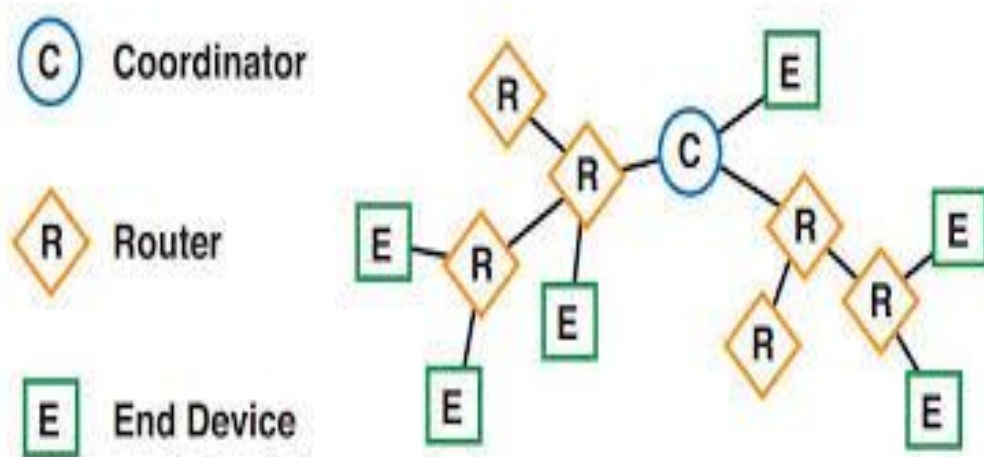

Figure 2 ZigBee Network

On the other hand, the router is responsible for the forwarding of packets from an end node to the coordinator in a multi-hop fashion. It should be noted that Zigbee also allows for the broadcast of data. In addition, the router is also not allowed to go to sleep.

Finally, the End node is another RFD that is used mainly for sensing the environment. The End nodes are allowed to sleep and new nodes can be allowed to join the network depending on the application. ZigBee allows up to 64,000 nodes to join a single network and it can support up to 240 end nodes having different application but sharing the same radio [54].

3.3.2 WirelessHART

WirelessHART is a wireless communication standard for industrial application base on Highway Addressable Remote Transducer (HART) communication protocol. The topology in wireless hart adopts star, mesh or combined. The timeslots in this standard are fixed at 10ms. WirelessHART supports frequency hopping and channel blacklisting in order to be more robust and reliable. It is supported by many suppliers like Pepperl+Fuchs and ABB and is compatible with other HART systems.

3.3.3 ISA100.11.a

The standard ISA100.11a is a system for industrial automation, which is designed to provide reliability and security wireless communication for monitoring and controlling non-critical industrial applications [53]. It is an implemented base on a hybrid MAC layer, which adopts a Carrier Sense Multiple Access with Collision Avoidance (CSMA/CA) and Time Division Multiple Access (TDMA). It has a flexible time slot with configurable length for allowing more flexibility to be used in different applications. In

addition, the ISA100.11a supports frequency hopping and channel blacklisting to be more robust and reliable. Wired networks like PROFIBUS, MODBUS, HART, and Foundation field can be compatible with ISA100.11a using tunneling techniques [55]. Nowadays, the implementation of ISA100.11a stack encounters some technical challenges in terms of installation on low cost hardware. Table 2 illustrate the comparison between the three standards [56].

Table 2 Industrial Wireless standard comparison

Comparison key	ZigBee	WirelessHART	ISA100.11a
Operating frequency	868 MHz,915 MHz, 2.4 GHz	2.4 GHz	2.4 GHz
Radio frequency transmission	DSSS 2.4 GHz with 16 channels	FHSS 2.4 GHz with 15 channels	FHSS 2.4 GHz with 16 channel
Medium Access control	CSMA/CA	TDMA or CSMA/CA	TDMA or CSMA/CA
Data rate	20,40,250 kbps depends on the operating frequency	250 kbps	250 kbps
Topology	Mesh, star or combined	Mesh, star or combined	Mesh, star or combined
Security	AES-128, and symmetric keys	AES-128, and symmetric keys	AES-128, and symmetric or asymmetric keys
Energy consumption	Low energy consumption	Low energy consumption	Low energy consumption

3.4 Industrial gases and their properties

It is very important to learn the origin of toxic gases as well their effects on human health. This information will help to avoid the effects of such parameters in future. These Gases originate from the atmosphere, the decay of organic matter, geochemical reactions and thermal decomposition of organic and inorganic compounds. Although these gases are mostly found in a small quantity, they can be found in large quantity if certain geologic conditions are evident and they could escape while drilling causing fires or a toxic or corrosive atmosphere. Since our research is more interested in Carbone monoxide (CO) and Methane (CH₄), these gases will discussed below:

3.4.1 Carbone monoxide (CO)

Carbon monoxide is one of the most notorious inorganic pollutants in the air. The bulk of carbon monoxide production is due to human activity, largely due to the combustion of carbonaceous materials when used as fuel or in industrial processes [57]. Carbon monoxide is naturally formed during oxidation of methane during the plant decay. So far carbon monoxide is not found in large quantities deep underground, but a sparse quantity is found in underground coal mines and in volcanic and mash gases [58].

Carbon monoxide is poisonous. When inhaled it combines with red blood cells hemoglobin to form Carboxyhemoglobin. This compound has a stronger bond than Oxyhemoglobin a compound that helps transport oxygen to the different parts of the body and prevents oxygenation of blood, Table 3 shows the effect of carbon monoxide on the body [59]. However, Carbon monoxide has some useful applications; it is used in coloring meat to make look fresh, it is used alongside other chemicals to forms anti-

inflammatories and vasodilators, also it is also used as an ablating medium in high power lasers and it is used in the production of iron and steel.

Table 3 Carbon Monoxide Effects

Effect	Concentration %
Normal presence of carboxyhemoglobin in blood	0.5-0.8
Patients with cardiovascular disease get impaired cardiovascular function	3-5
Carboxyhemoglobin in smokers blood	3-10
Slight headache	10-20
Impaired visual function	>20
Coma accompanied with intermittent convulsions	50-60
Death	70-80

Physical properties of Carbon monoxide

The following are some physical properties of carbon monoxide;

1. Carbon monoxide is colorless.
2. It is odorless.
3. It has a density of 1.14kg/m^3 (slightly less dense than air).
4. It has a melting point -205.02°C and a boiling point -191.5°C .
5. It is soluble in acetic acid, ammonium hydroxide, benzene, chloroform, ethyl acetate, ethanol and water.

Chemical properties of Carbon monoxide

CO is the molecular formula of carbon monoxide. The structure consists of a carbon atom in two covalent bonds and a single dative covalent to bond the oxygen atom. Other chemical properties of carbon monoxide are:

1. It burns in the presence of oxygen to form carbon dioxide (CO₂).
2. It reacts with water to form carbon dioxide and hydrogen gas.
3. It reacts with nitrogen dioxide to form carbon dioxide and nitrogen(II)oxide.

3.4.2 Methane (CH₄)

Although scientists disagree over how methane is formed, the popular theory is that methane is formed as a result anaerobic decomposition of organic materials by bacteria known as Methanogenic bacteria [60][61]. Methane is the major constituent (70%-95%) of natural gas [62]. Methane combustion is more efficient than other fossil fuels and it also produce less carbon dioxide. It produces less toxic waste when used for electric energy production as compared to coal and it is found in abundance. Kotz et al. report that an estimate of $1.5 * 10^{13}$ tons of methane is buried under the sea floor around the world in the form of Methane Hydrate.

However, methane is a greenhouse gas, just like carbon dioxide and it destroys the ozone layer found in the upper atmosphere which protects us from solar radiation. Some of the techniques used in obtaining methane (such as fracking) from under the ground are not environment friendly. Further, the transportation and storage of natural gases is also expensive.

Physical properties of Methane

Some of the physical properties of Methane are;

1. Methane is colorless.
2. It is odorless.
3. It has a melting point of -182°C and a boiling point of -161.5°C
4. It has a density of 0.66kg/m^3 (lighter than air) at STP.
5. It is soluble in water.

Chemical properties of Methane:

Methane is also represented by the chemical formula CH_4 consists of a carbon atom in weak covalent bond with four hydrogen atoms. Other chemical properties of Methane are:

1. Methane is combustible, when it completely burns in oxygen it produce carbon dioxide and water.
2. It reacts with halogens in a process called Halogenation.
3. Methane is a weak acid.

Methane is not toxic but it is highly flammable. It burns at a temperature of (900 – 1500 $^{\circ}\text{C}$) with a blue flame and no smoke, making it the most efficient fossil fuel known so far.

3.5 Toxic and combustible gases sensors

It is very important to investigate gas sensors that are used to detect toxic or combustible gases because there are several techniques used in the context of identifying gases, such as Gas chromatography (GC)-based [63], non-dispersive infrared (NDIR)

[64], conductive polymer [65], electrochemical sensing technology [66], and metal oxide semiconductor [67].

GC-based sensing technology [63] refers to the gas sensing technology that utilizes a semi-selective gas sensor and adopts GC to enhance selectivity. GC plus mass spectrometry (MS) and flame ionization detector (FID) are standard gas analyzers for stationary air pollutant monitoring sites. GC-based gas analyzers achieve high sensitivity, selectivity, and reliability. However, traditional GC-based gas analyzers are bulky and expensive; require complex operations and regular maintenance. Although development of micro GC [68], micro MS [69], and 10 micro FID [70] have been reported during last decade, the GC's high degree of complexity and sophistication still results high production cost and maintenance effects. In addition, the operation of GC-based gas analyzers involves a gas sampling process and a pre-concentration process, which brings significant drawbacks. The gas sampling process is time consuming, usually taking minutes to output one dataset. Thus the sampling rate is pretty low. The gas pre-concentration process needs a high-power-consumption heater to release absorbed gas analytes. Thus the power consumption of GC-based gas analyzers is inefficient.

NDIR sensing technology [64] detects gas by determining the absorption of an emitted infrared light source through a certain air sample. Commercial NDIR sensors can detect air pollutants – CO, NO, SO₂, O₃ and VOCs. NDIR sensors exhibit good sensitivity and good stability. However, they necessitate a relatively complicated optical system, making it expensive, bulky and high power consumption (hundred mW).

Conductive polymer sensing technology [65] uses different types of conductive polymer to absorb or react with a specific gas, causing a change of the polymer film

resistance. It has been reported as capable of sensing CO, NO₂ and a few VOCs in the air pollutant category. Conductive polymer based sensors consume low power given their room-temperature operations. They exhibit high sensitivity and short response time to analytes. They have low fabrication cost because of a simple fabrication process and are easy to miniaturize. However, they suffer low selectivity, long-term instability and irreversibility.

Electrochemical sensing technology [66] utilizes electrochemical reaction to generate an electrical signal (current or potential) to sense gases. Electrochemical sensors have been proven to be effective for detecting environmental gases such as CH₄, CO, CO₂, NO, NO₂, SO₂, H₂, O₃, O₂ and VOCs. They exhibit good selectivity, low power consumption (in liquid electrolyte), wide dynamic range and low production cost. Their response time and reliability vary with the electrolyte. They have the potential to be miniaturized with the newly-developed electrolytes.

In this research Metal oxide sensors was used as a gas sensor detectors. They work base on the principle that certain gases alter with normal performance of solid state devices.

3.5.1 Metal oxide sensors

The notion of using metal oxide sensors was referred to 1952 when Brattain and Bardeen noted that the gas adsorption of germanium semiconductor surface caused a variation in its electrical conductivity [71]. The first realization of a working gas sensor was in 1962, when Seiyama et al. [72] detailed the use of zinc oxide ZnO thin films in the detection of gases as ethanol (C₂H₆O) and carbon dioxide (CO₂). Then, the detection of hydro-gen (H₂), oxygen (O₂) and hydrocarbon by means of surface conductivity changes

on various metal oxide crystals and thin films have been proposed and demonstrated [73]. Although, many metal oxides have been successfully demonstrated in gas sensing, SnO₂ and ZnO have been intensively investigated fundamentally and commercially due to the attractive structural, optical and electrical properties.

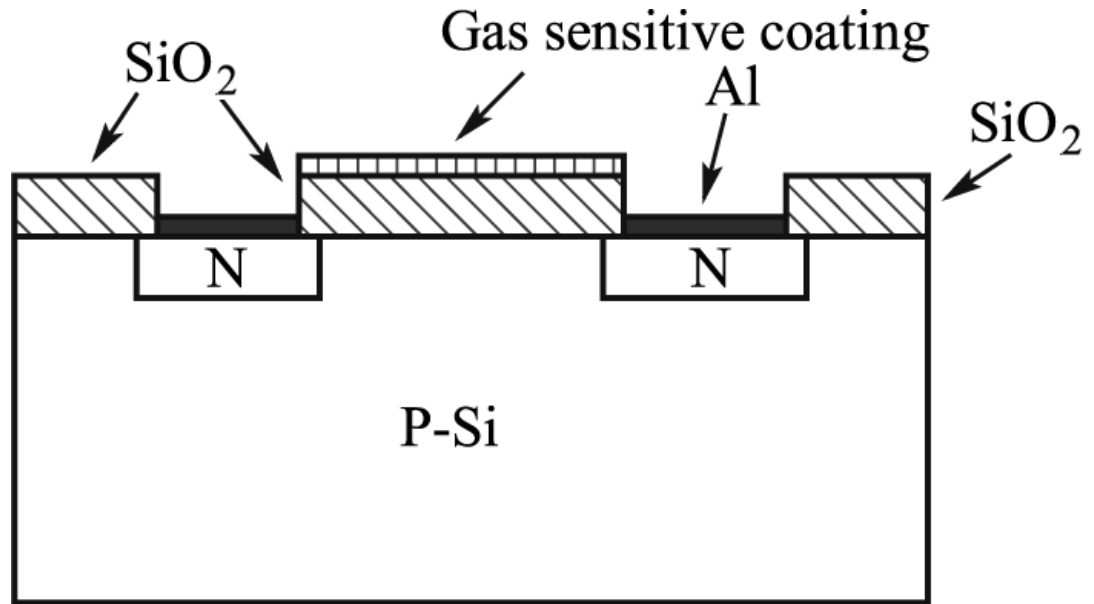

Figure 3 Semiconductor gas sensitive

The resistance of n-type semiconductors (usually doped with Tin oxide (SnO₂)) decreases upon contact with a reducing agent and increases when it comes in contact with an oxidizing one. Conversely, p-type (figure 3) semiconductors (usually doped with Copper oxide (CuO)) have the opposite response [74].

Semiconductor sensors are usually used in sense toxic gases, but are sometimes used in sensing combustible gases too. Figure 4 shows semiconductor gas sensors with heating coil. Typically, the sensor has a heating element which could be made up of platinum coil, a resistive metal oxide, or a thin layer of deposited platinum. The heater heats the semiconductor to a temperature of 100° C – 500° C.

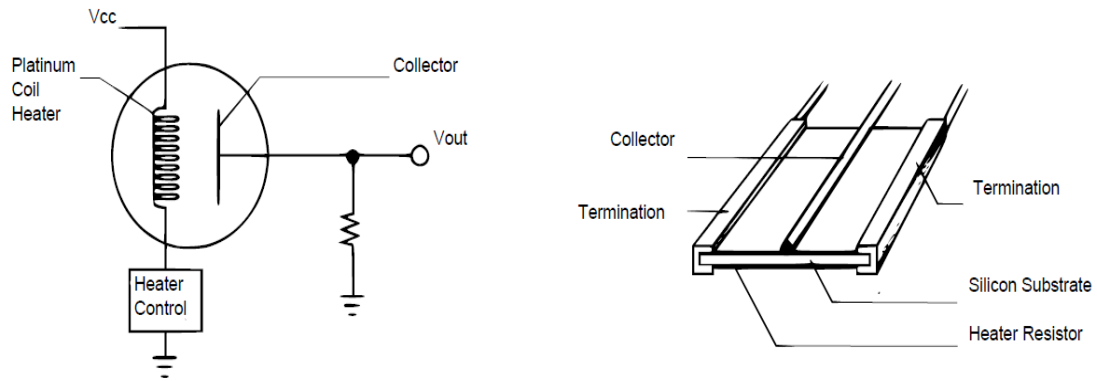

Figure 4 Toxic and combustible gas sensor

Semiconductor sensors are good for detecting low ppm levels of gases, as well as high combustible levels, they are also robust with a life expectancy of at least 10 years [75], they are also flexible in that same gas sensor can measure toxic and combustible gas, they operate in wide range of temperature and humidity [76]. Huge energy consumption and false alarm are some of semiconductor sensor's drawbacks.

Yayavaram et al. [77] reported that semiconductor sensors readings in general follow the power law as shown by Equation 3.1 .

$$R = K * C^{\pm n} \quad (3.1)$$

$$R = \frac{R_s}{R_o} \quad (3.2)$$

Where

R = Electrical resistance of the sensor

K = measurement constant of the sensor material

C = Concentration of the target gas in ppm

n=sensitivity index of the material (between 0.3-0.8)

Table 4 Comparison of sensing technology

Sensing Technology	GC	NDIR	conductive polymer	electrochemical	metal oxide semiconductor
Sensitivity	Excellent	Good	Bad	Good	Good
reliability	Excellent	Good	Bad	Moderate	Moderate
Power consumption	Bad	Bad	Good	Good	Moderate
Low cost	Bad	Bad	Good	Good	Good
Fast response	Bad	Good	Good	Moderate	Good

CHAPTER 4

SYSTEM ARCHITECTURE

4.1 Introduction

The development of system consists of both hardware and software requirements. The working environment to build the application is setup with all the required hardware components. Software application is then developed which will later be tested on the hardware platform thoroughly. This chapter explains step-by-step development of hardware system followed by software development and its implementation.

4.2 System hardware design

This system is basically a stack of several boards starting with Arduino board as a base, GPS module on top of it, then XBee module on top of XBee shield , and sensor board shield on top level, which makes system looks compact in size and very handy to use (Fig.5). This chapter gives detailed review of each of this part along with its working principle.

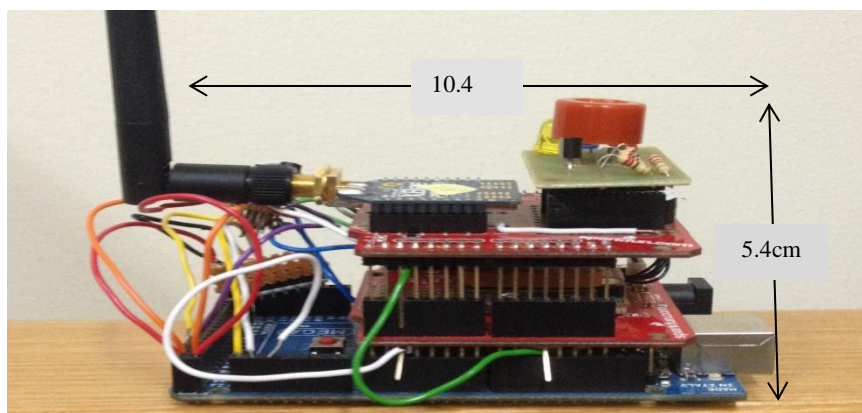

Figure 5 designed end node

4.2.1 Arduino Mega 2560

A few decades ago electronic devices were very complicated and difficult to deal with and also more expensive. However, nowadays with advances in the developments of hardware as well as the emerging of open-source hardware, it has become easier to build an electronic device yourself. Arduino is a well-known microcontroller board (Figure 6) that is quite easy to program and integrate with a variety of other hardware.

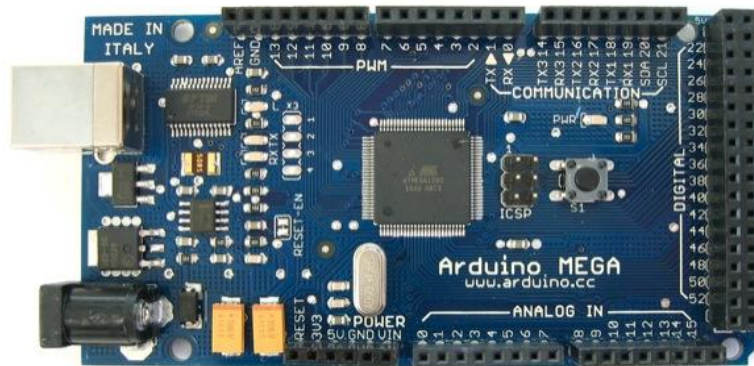

Figure 6 ARDUINO MEGA 2560

One powerful aspect of the open-source electronic device (Arduino) is its flexibility and it has easy to use hardware and software. For anyone interested in creating an interactive prototype or sensing the environment, Arduino would be a good option to create these objects. Arduino is used to sense the environment by receiving the signals from the sensor and can make a reaction by controlling alarms or any actuators. The heart of Arduino board is the microcontroller which can be programmed using The IDE (Integrated Development Environment) platform that allows writing sketches for the Arduino board in a simple language.

Arduino Mega 2560 has ATmega2560 [78] CMOS 8-bit microcontroller that consumes a low power base on AVR Reduced instruction set computing (RISC). The

throughput is around 1 MIPS per MHz which is achieved by executing many instructions in one clock cycle leading to an optimization in power consumption as well as speed. It consumes 20mA for DC current in input and output pins and 50mA for 3.3V pin. Arduino provides many features as following: operating at 5V, 54 digital input pins 15 of them provide PWM, 16 analog input pins, 16 MHz clock speed, 256 KB flash memory, 8 KB SRAM, 4KB for EEPROM [79]. Figure 7 illustrate the schematic diagram of Arduino Mega 2560 [80].

Arduino™ MEGA 2560

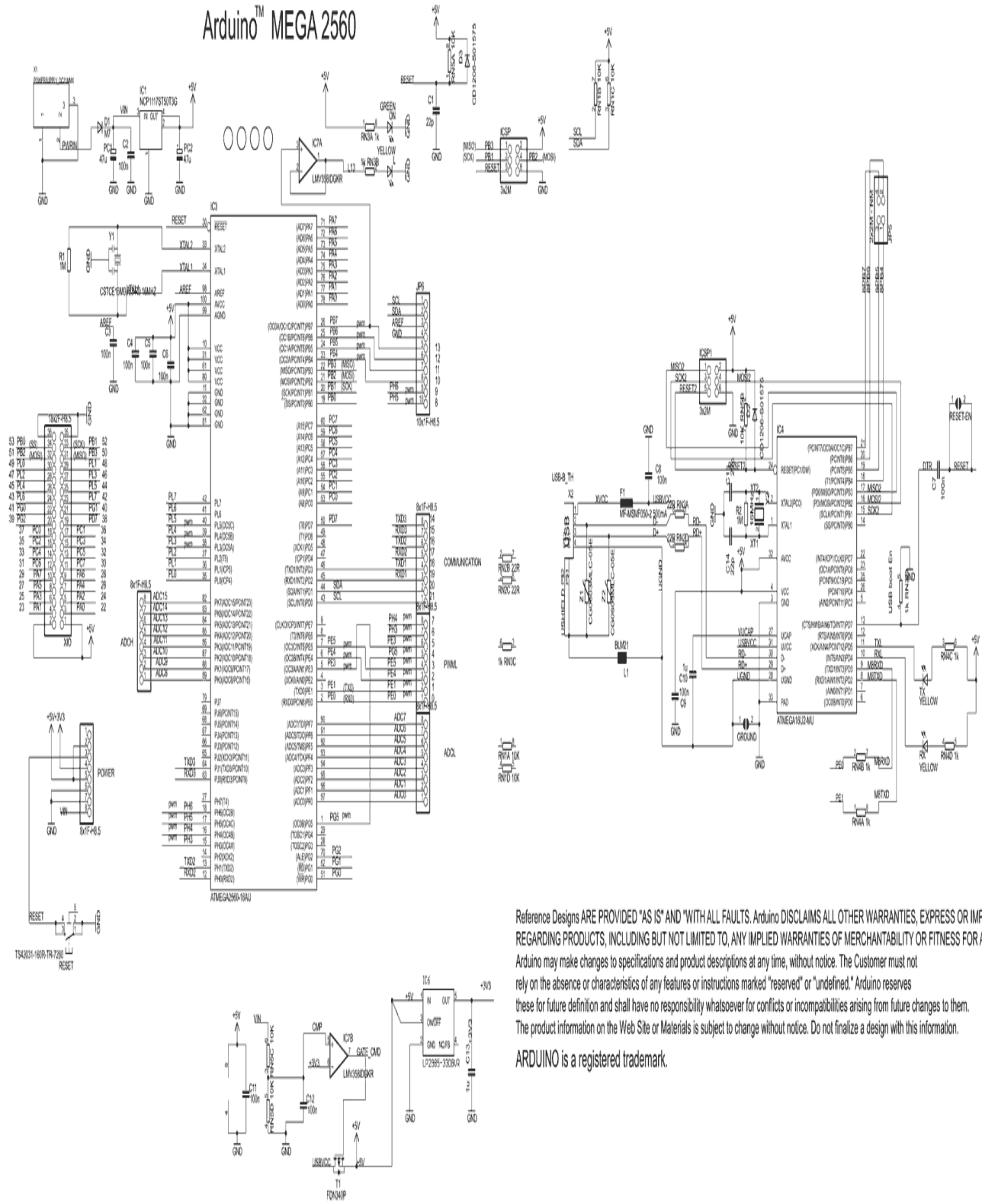

Reference Designs ARE PROVIDED "AS IS" AND "WITH ALL FAULTS." Arduino DISCLAIMS ALL OTHER WARRANTIES, EXPRESS OR IMPLIED, REGARDING PRODUCTS, INCLUDING BUT NOT LIMITED TO, ANY IMPLIED WARRANTIES OF MERCHANTABILITY OR FITNESS FOR A PARTICULAR PURPOSE. Arduino may make changes to specifications and product descriptions at any time, without notice. The Customer must not rely on the absence or characteristics of any features or instructions marked "reserved" or "undefined." Arduino reserves these for future definition and shall have no responsibility whatsoever for conflicts or incompatibilities arising from future changes to them. The product information on the Web Site or Materials is subject to change without notice. Do not finalize a design with this information.

ARDUINO is a registered trademark.

Figure 7 Arduino Mega 2560 schematic

4.2.2 Xbee communication module

To build a reliable and robust system to monitor toxic or combustible gases in oil field, it is very important to have robust wireless sensor network that covers all parts of oil and/or gas field. So while choosing components for such network, cost and distance covered are the main factors that need to be considered. XBee is such module having highly reliable data transmission and receiver modes. The version used in this thesis is The XBee pro S2B [81] as shown in figure8.

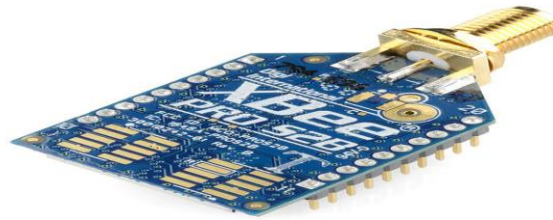

Figure 8 XBee PRO S2B Module

The XBee RF Modules interface with another device through a logic-level asynchronous serial port. If there is a logic and voltage support Universal Asynchronous Receiver/Transmitter (UART) as shown in figure 9, it can communicate with it or through a level translator to any serial device such as RS-232 or USB. The pins of RF module can be connected directly to any device has a UART interface figure9 illustrate the data flow in UART environment.

Serial communications depend on the two UARTs (the microcontroller's and the RF module's) to be configured with compatible settings (baud rate, parity, start bits, stop bits, data bits). The UART baud rate, parity, and stop bits settings on the XBee module can be configured with the BD, NB, and SB commands respectively.

There are five different operation modes of XBee:

1. Idle mode: the module is on but no data to transmit or receive.
2. Transmit mode: data from serial received in data input pin.
3. Receive mode: data received to the module from antenna.
4. Sleep mode: most parts of the module are switched off and it enter a low power state.
5. Command mode: the receiving data is translated into commands to modify the module parameters.

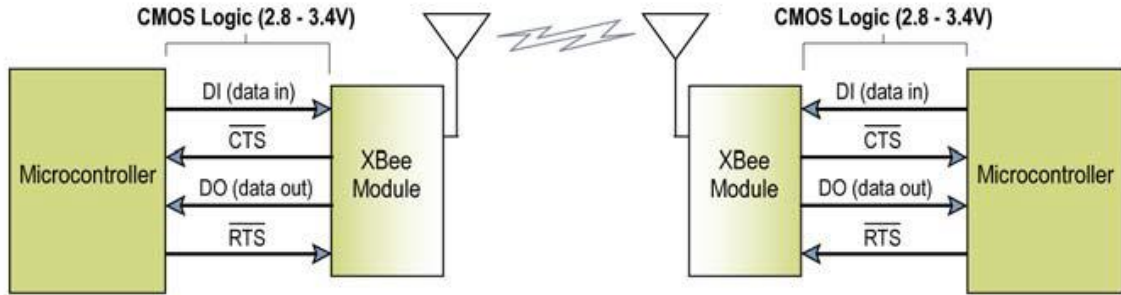

Figure 9 Data flow diagram in UART

4.2.2.1 Xbee routing

Mesh topology is used to establish a route between the coordinator and end devices. The network devices participate in forming a route between source and destination. Ad-hoc On-demand Distance Vector (AODV) routing protocol performs the basis for routing discovery. The routing discovery is established when a source node sends data to a destination node. The source node sends a broadcast route request which contains its address, destination address and a cost of path. When this request reaches to neighborhoods, they rebroadcast the request and store the path in its route table and update the path cost.

When the route request receives to the destination node, it distinguishes the better path cost by comparing the received route requests. Then the destination node transmits a route reply packet to the source node. Figure 10 illustrate the AODV protocol.

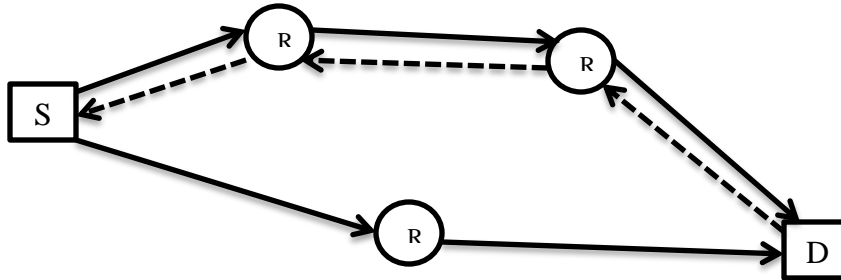

Figure 10 AODV route request and route reply mechanism

In order to have reliable connection, Zigbee includes different acknowledgements. One is at MAC layer between the neighbors when one node transmits to its neighbor node an acknowledgement packet is transmitted to the opposite side of the data packet to make sure that the transmission is successful. If the acknowledgement is not received, the data packet will be retransmitted up to 4 times. The other acknowledgement is at the application layer between the source and destination. This acknowledgement follows the same path of the data packet on the opposite side. If the source does not receive the acknowledgement, it will retransmit the data packet up to two times [82].

4.2.2.2 Building wireless mesh network

Xbee devices build an Xbee network automatically. One coordinator and several routers are used to form out mesh network. We have assigned a specific Personal Area Network ID (PAN) to the coordinator node which scans the available channel to begin a Zigbee mesh network. Also a router can join the network (either a coordinator or another router) by scanning available PAN ID in its range. If it discovers a device operate with

the same PAN ID, it transmits a request for association. On the other hand, the receiver replies with a respond frame to allow the sender to join the network. After that a broadcast frame is sent by the joining router to discover the coordinator 64 bits address. A maximum of 8 end nodes can join each coordinator or router. Figures 11, 12 show the coordinator settings and network working mode in XCTU software.

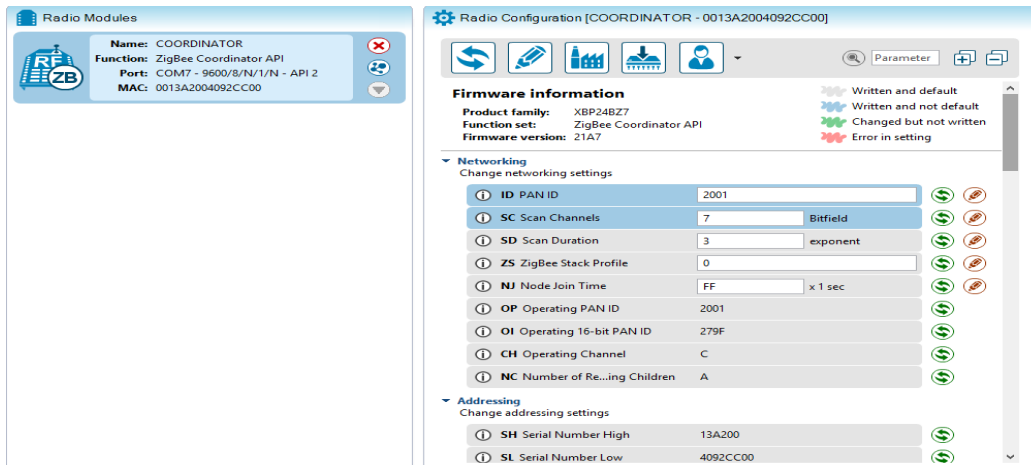

Figure 11 Coordinator settings

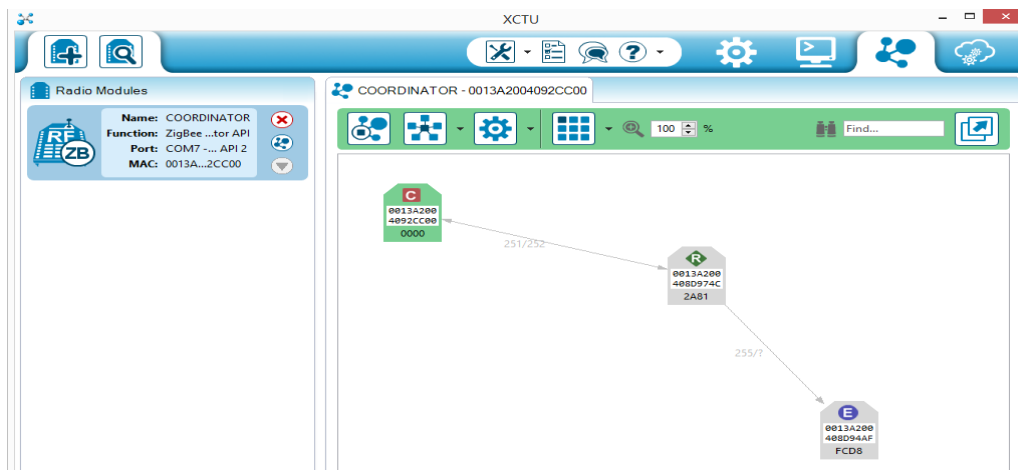

Figure 12 Network working mode

4.2.2.3 XBee shield

Xbee shield (see figure 13) is used to provide an interface between the Arduino board and the Xbee wireless module. It is compatible with all versions of Xbee modules including series one and two either standard or Pro [83].

The single-pole, double-throw (SPDT) switch connect the serial pins (DIN, DOUT) of the Xbee to either the digital pins (2, 3) on the Arduino or UART pins (D0, D1). A regulator regulates the 5V that comes from Arduino to 3.3V DC to provide Xbee with its operation power. In addition, The Xbee shield contain LEDs to indicate usage of RSSI, DIO5, DIN, DOUT pins of the Xbee module. The reset button on the Arduino is transferred on the shield, and a grid of holes that we use it to connect our prototype of sensor. Figure14 shows the schematic of the Xbee shield [84].

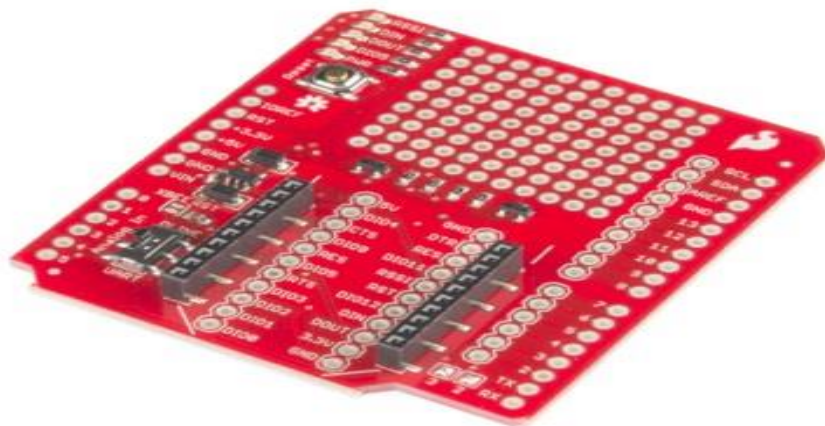

Figure 13 XBee Shield

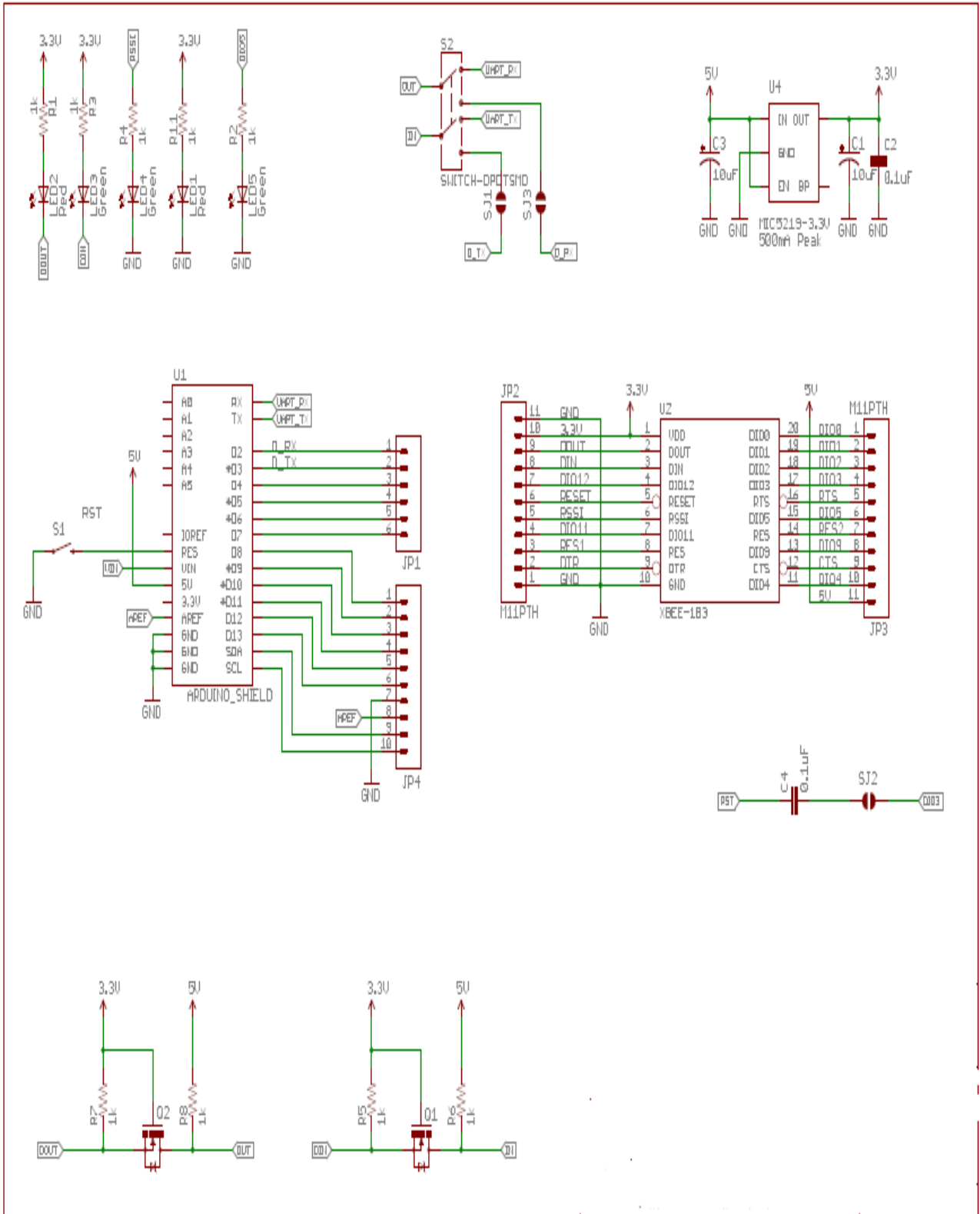

Figure 14 XBee shield schematic

4.2.3 GPS module

A GPS module is added to locate where the gas detection occurred. It includes a power regulator, LED to indicate it has received data from satellite, interface pins, and built-in antennas. This module is supported by SiRFstarV, and provides good sensitivity even in dense environments. The time needed to obtain data from this GPS module is less than 15 seconds because it uses GCEE (client Generated Extended Ephemeris) technology. To adopt GPS module with Arduino board, a GPS shield acts as interface between the two was added as in Figure 15.

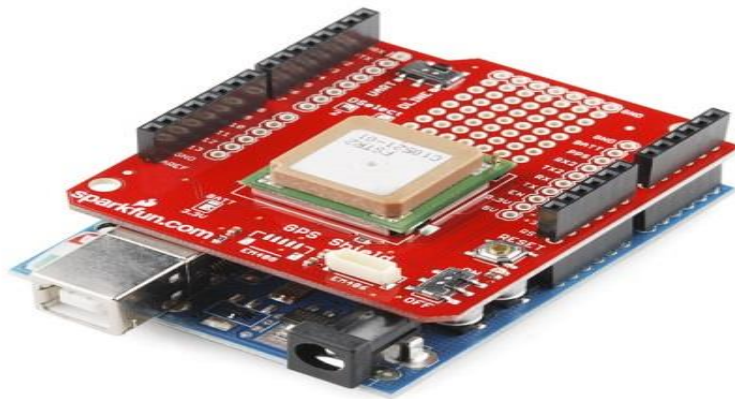

Figure 15 GPS module and GPS shield on top of arduino

In addition, GPS coordinates is used to calculate the distance between the location of the detecting sensor and notified sensor by using Haversine formula as following:

$$a = \sin^2\left(\frac{\Delta latitudes}{2}\right) + \cos(Latitude1) * \cos(Latitude2) * \sin^2\left(\frac{\Delta lonitudes}{2}\right) \quad (4.1)$$

$$c = 2 * \sin^{-1}(a) \quad (4.2)$$

$$d = R * c \quad (4.3)$$

Where R is the earth radius 3956.6 km and d is the distance between the two coordinates.

4.2.4 Accelerometer

The MPU-6050 has the ability to detect motions, using the 3-axis accelerometer. It is used in the design of sensor to detect mobility of the moving target. If the wearer moves, the sensor sends data more frequent and takes more sample of sensing data. Also it can be used to save power by putting the sensor in a sleep mode when it is idle.

An I2C communication bus is used to transfer data to Arduino at 400 kHz. It contains three analog to digital converters (ADCs) outputs for digitalizing the accelerometer data.

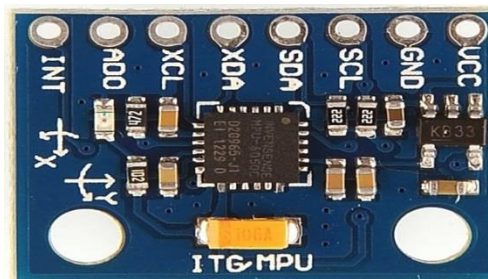

Figure 16 MPU-6050 motion detector module

4.2.5 Gas sensor

A semi-conductor gas sensor acts as a variable resistor whose resistance either falls or rises (depending on the semi-conduction's doping) during gas leakage. As such each of the sensors is connected in a potential divider with 10k resistor and the voltage is measured with reference to the ground. Figure 17 shows the Printed Circuit Board (PCB) of the sensor used in the proposed sensor node.

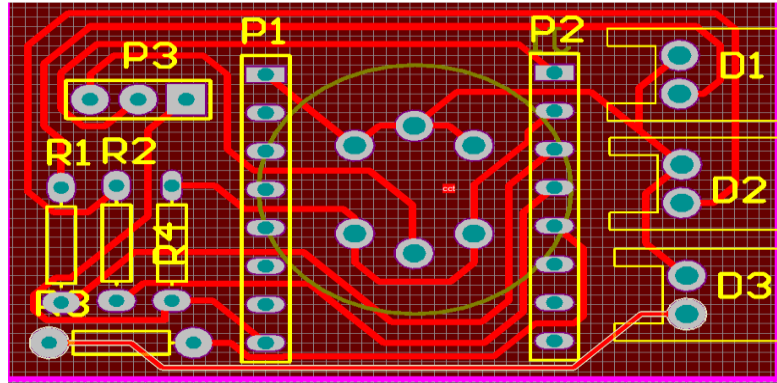

Figure 17 Gas sensor board

The sensor used in sensor node is MQ-7 (Figure 18), which provides high sensitivity and fast response. The sensor contains coil for heating, load resistance, and analog output connected to ADC to the Arduino.

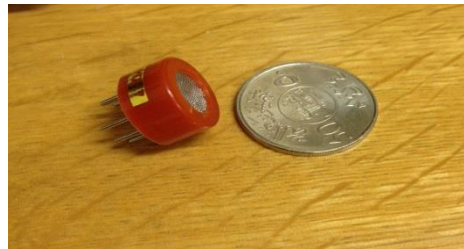

Figure 18 MQ-7 sensor

The sensor constructed of Al_2O_3 ceramic tube, sensing material of Tin Dioxide (SnO_2), electrode for measuring, and heater to provide conditions of sensing. All these components are put into a plastic crust with stainless steel grid. The MQ-7 has six pins, two of them used for heater and the other four for signals. Figures 19 and 20 show the circuit diagram of the sensor board.

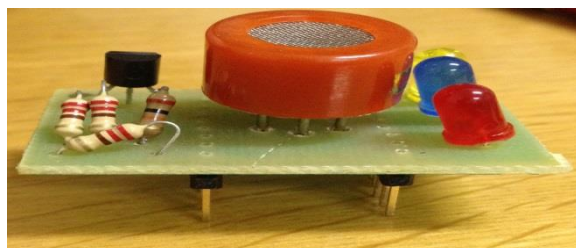

Figure 19 Sensor board

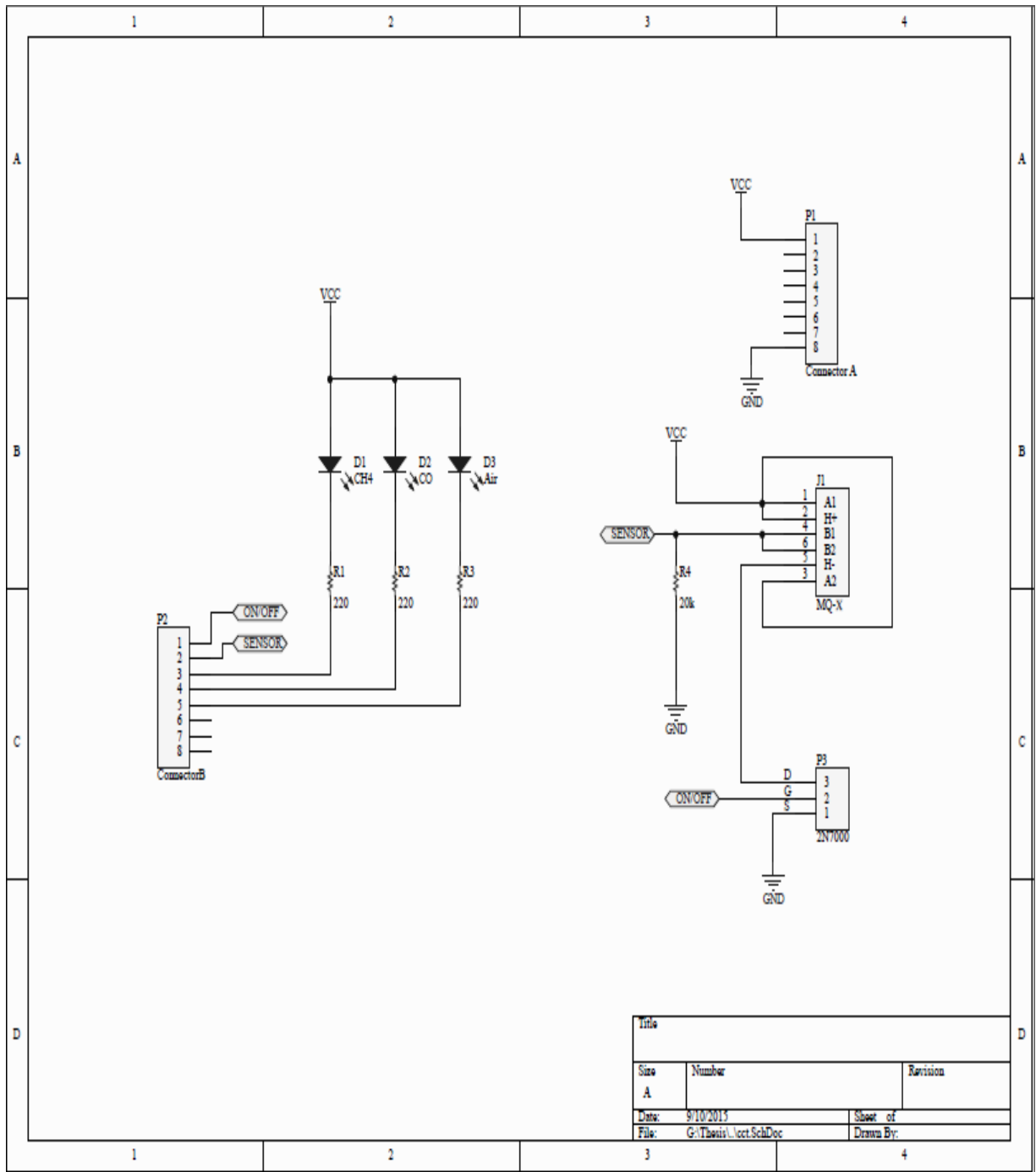

Figure 20 Circuit diagram of gas sensor board

4.3 System software design

Software design of this system has mainly two parts. Arduino boards need to be programmed in order to measure sensor readings and forward them, and a coordinator program should be installed on a PC. Each type of nodes has their own application tailored for the function they are designed to carry out. In next subsection, functionality of those are explained.

4.3.1 Sensor node software

The software developed for gas sensor nodes are installed in the Arduino microcontroller board. Figure 21 depicts a flowchart designed for the program of the sensor node. At the beginning, the sensor listens for 30 seconds to detect if whether coordinator sends another sensor's reading. If the sensor receives data, it checks whether this data is within the concerned area, in order to start an alarm and to check a sensor movement. On the other hand, if no data is received, the sensor node tracks the movement. If no movement, it goes to sleep for 30 seconds (this is a tunable parameter according to the nature of the application); otherwise it turns on the gas sensor and the GPS is also powered. The node then allows the gas sensor to heat up and the GPS module to synchronize with GPS satellites while it carries out other activities. After getting sensing readings from MQ-7 sensor, it sets the alarm on if the readings are above a threshold and broadcasts the data. Then it detects the sensor movement to send data more frequently. If the reading is below the threshold, it broadcasts directly through the Xbee module and goes to sleep for one minute to save power (this is a tunable parameter according to the nature of the application).

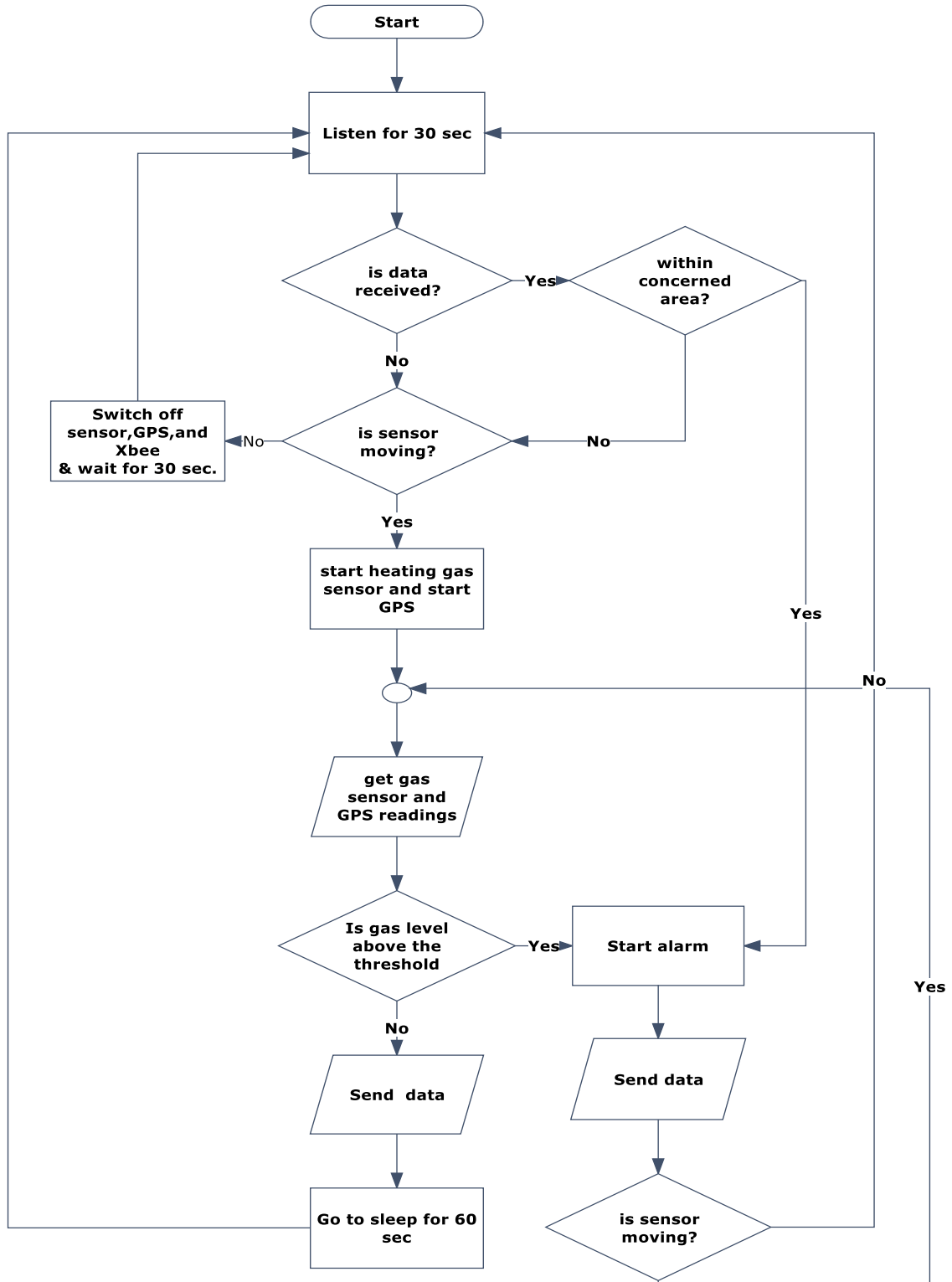

Figure 21 Flowchart of sensor node software

The API packet format that is transmitted by the sensor node is formatted as shown in figure 22. The first 16 bytes are headers files that include payload size, 64 bits MAC address and 16 bits network address of the sensor. After that n bytes will represent sensor readings divided into 2 cells (CO, and CH₄) and GPS data (longitude and latitude). The last byte is the checksum.

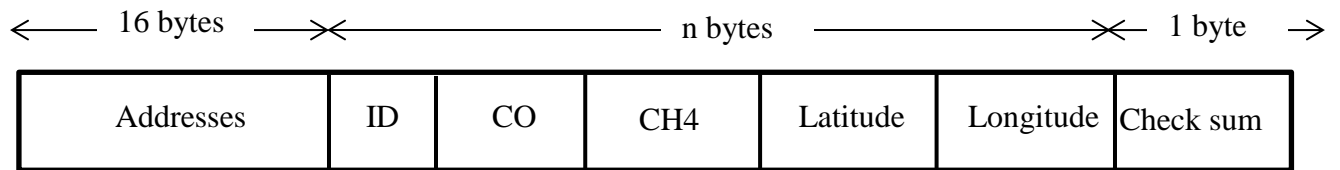

Figure 22 API packet format

4.3.2 Coordinator software

The coordinator node acts as a sink to the sensor network and gateway between the network and coordinator's PC. It collects data form the network and sends it to the coordinator's PC via serial connection. It is constructed from an Arduino board and Xbee module.

The Coordinator's PC is programmed to receive data from the sensor network and process it as shown in Figure 23. The program listens to the COM port selected where the data will come from. As soon as serial data is received, checksum is calculated using the formula of Equation 4.1. The calculated checksum is compared with the received checksum (i.e. the value in the last field of the frame) and the system returns to its listening state when the data is received with errors. After receiving correct data, the coordinator node starts an alarm and sends notification to the other end nodes if the gas data is above the threshold. Then it adds a node record in case that the node is sending to the coordinator node for a first time. If it is already added, it updates the node record and

checks the existence of nodes which mean that all workers are in their positions. It reports the missing node if it is not receiving its data for a long time.

$$\text{Checksum} = 0xFF - \left(\sum_{k=3}^{n-1} \text{receivedByte}_k \right) \bmod 0xFF \quad (4.1)$$

4.4 Router node

To increase the distance of communication between the sensor node and the coordinator, a router node can be deployed in field to ensure that the concern area is covered. Router nodes consists of Arduino module with Xbee module and do not require any special programming. It is responsible for moving data for one node to another

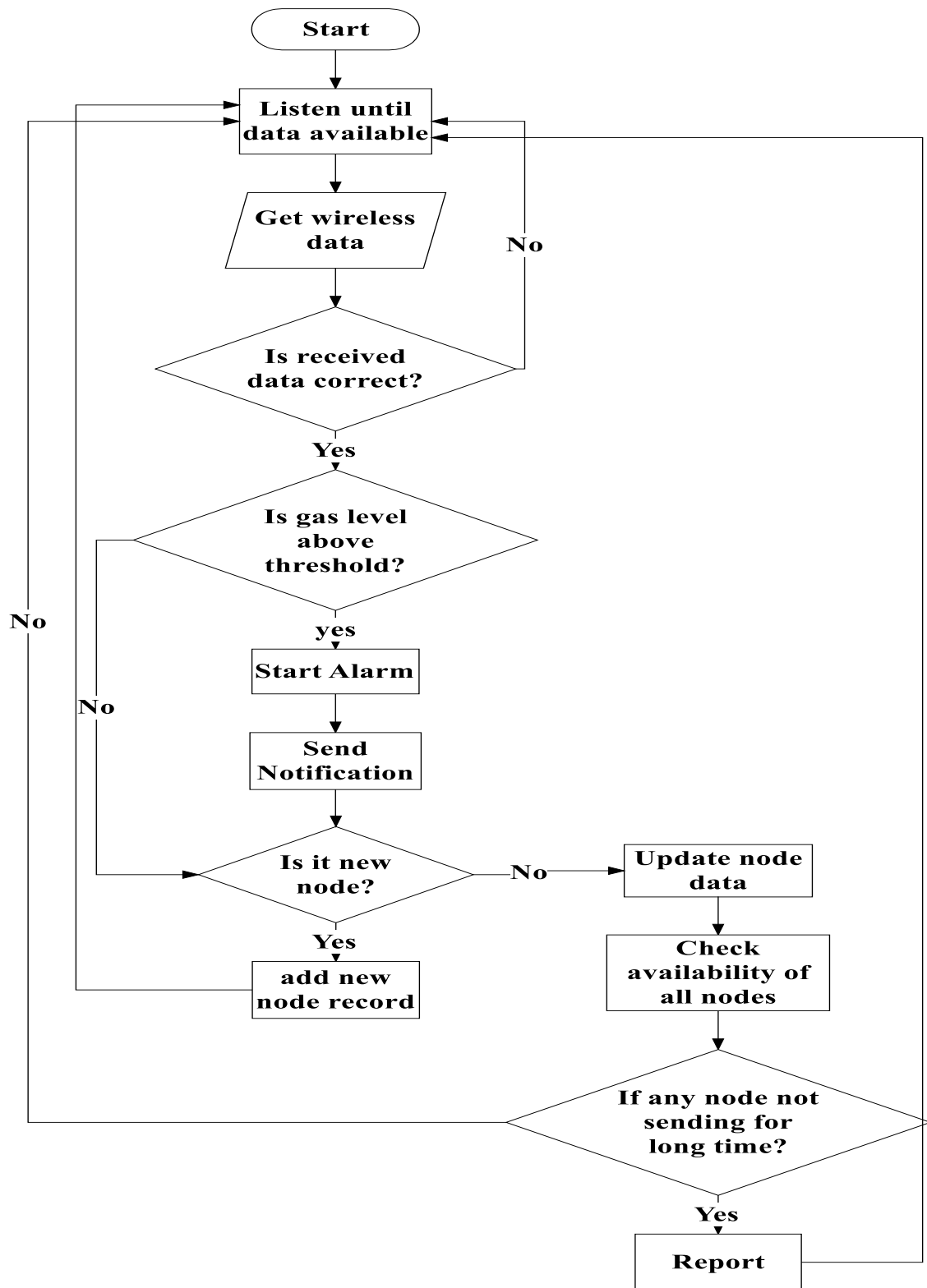

Figure 23 coordinator flowchart

CHAPTER 5

RESULTS AND CONCLUSION

5.1 Introduction:

This chapter outlines the experiments conducted with the system. The first experiment explains the practicality of the system. The second experiment investigates the power consumption of the designed sensor node.

5.2 System Experiment

For any system it is very important to be working properly as desired. The proposed system needs to pass this hurdle by giving good results during its initial testing period. The electrical characteristics of the gas sensor are from the datasheet in [85]. Mathematical models are derived in order to determine the concentration of gas in a given area. The graph from datasheet is used to obtain (R_s/R_o) where R_o is sensor resistance at 100ppm of CO in the clean air and R_s is sensor resistance at different concentrations of gases. It should be noted that R_s is described in terms of voltage drop across the resistor instead of Ohms. This is possible because the earlier and the latter are directly proportional. The used of a voltage drop allows us to easily derive the gas readings from the microcontroller perspective. These models are represented by the equations 5.1 and 5.2.

$$CO_C = 106.73 * \left(\frac{R_s}{R_o}\right)^{-1.508} (\text{PPM}) \quad (5.2)$$

$$CH4_C = 2E13 * \left(\frac{R_s}{R_o}\right)^{-10.13} (\text{PPM}) \quad (5.2)$$

5.2.1 Calibrating MQ-7:

The ideal way to calibrate the gas sensor (MQ-7) is to obtain measurements in known concentrations of CO. However, due to toxicity of the gas it is quite difficult to setup this environment. The other way is to obtain gas measurements in absence of CO, the equation below illustrates that using voltage divider:

$$I_{R_L} = I_{R_s} \quad (5.3)$$

$$\frac{V_{R_L}}{R_L} = \frac{V_{R_s}}{R_s} \quad (5.4)$$

$$\frac{V_{R_L}}{R_L} = \frac{(V_{in} - V_{R_L})}{R_s} \quad (5.5)$$

$$R_s = \frac{(V_{in} - V_{R_L}) * R_L}{V_{R_L}} \quad (5.6)$$

Where I_{R_L} and I_{R_s} is current pass through the load resistance and sensor resistance respectively, V_{R_L} is the voltage drop on the load resistance, V_{in} is the input voltage. Now R_o indicates the resistance of MQ-7 at low concentration of CO so that the value of R_s/R_o should be near the value when there is no existence of toxic gases.

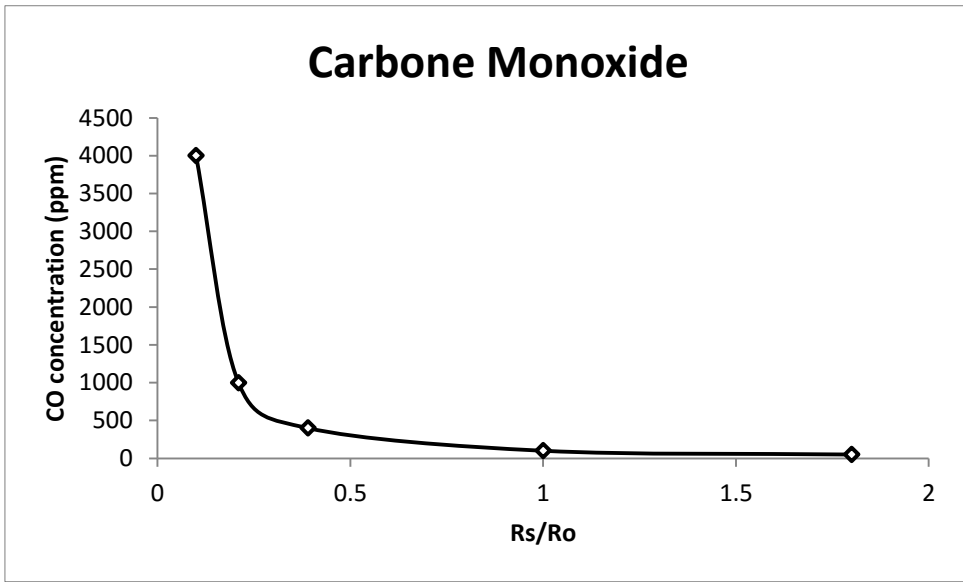

Figure 24 CO concentration in part per million

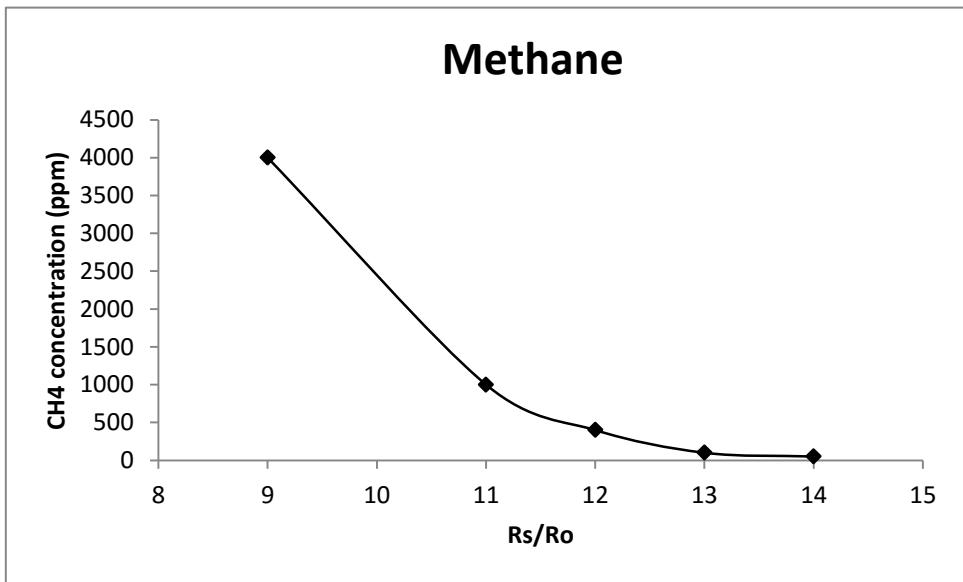

Figure 25 CH₄ concentration in part per million

5.2.2 System test

The first system test experiment is conducted outside collage of computer science and engineering at King Fahd University of Petroleum and Minerals (KFUPM). The sensor node is placed in different locations, which are at distance of 70-80 meters form the coordinator. The coordinator program collected the sensor node data and displayed it on a serial monitor in coordinator PC. Figure 26 and 27 outline CH4 and CO concentration in air with time.

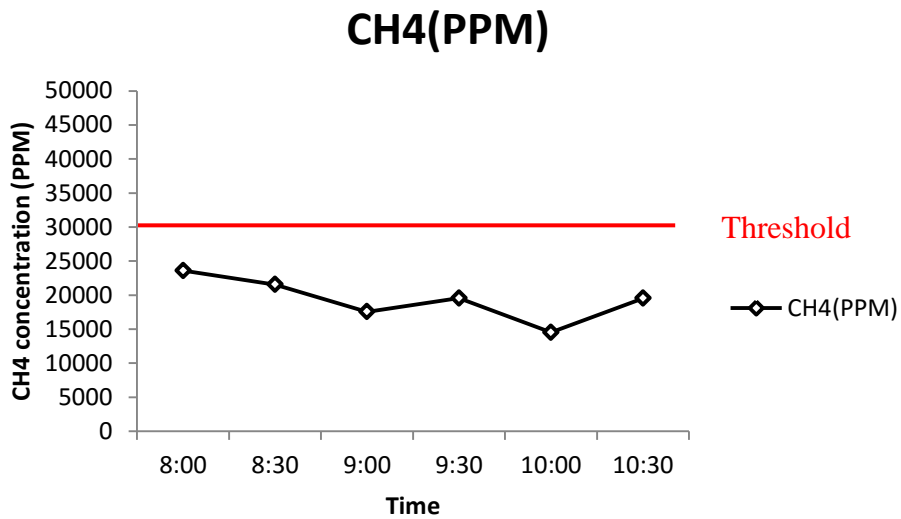

Figure 26 CH4 concentration results

CO(PPM)

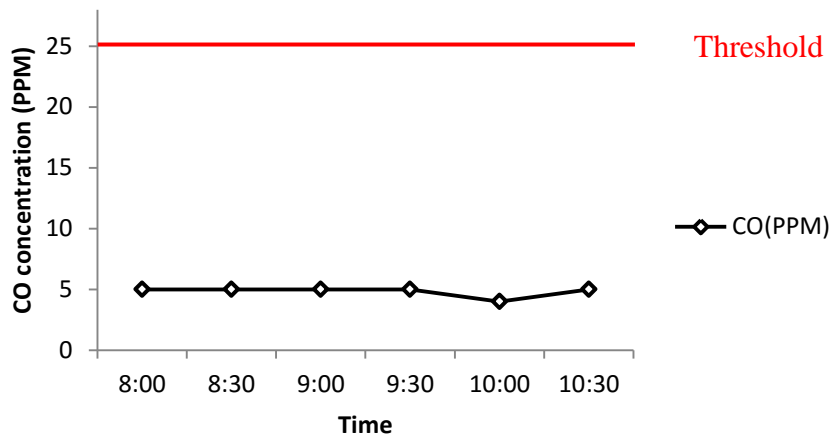

Figure 27 CO concentration results

To ensure the communication reliability between the end node and the coordinator, the Received Signal Strength Indicator (RSSI) is measured, which indicates an approximate value for the strength of a signal received. This measurement is helpful to determine the quality of connection between nodes. RSSI is measured in decibel-milliwatts. This unit is inversely proportional to the distance between the coordinator and the end node. For instance, if the distance between nodes increases, the RSSI value decreases, which indicates that the received signal is weak. Likewise, if the nodes move closer to each other, the signal strength increases and the connection between them is more reliable. Figure 28 illustrates the signal strength when the distance between the coordinator and the sensor node is around 35m whereas figure 29 shows the measurement when the distance is 75m. In the RSSI graphs the blue line represents the success communication, green line represents local RSSI and the red line represents the remote RSSI. In addition figure 30 shows the GPS coordinates of the sensor node in the experiment.

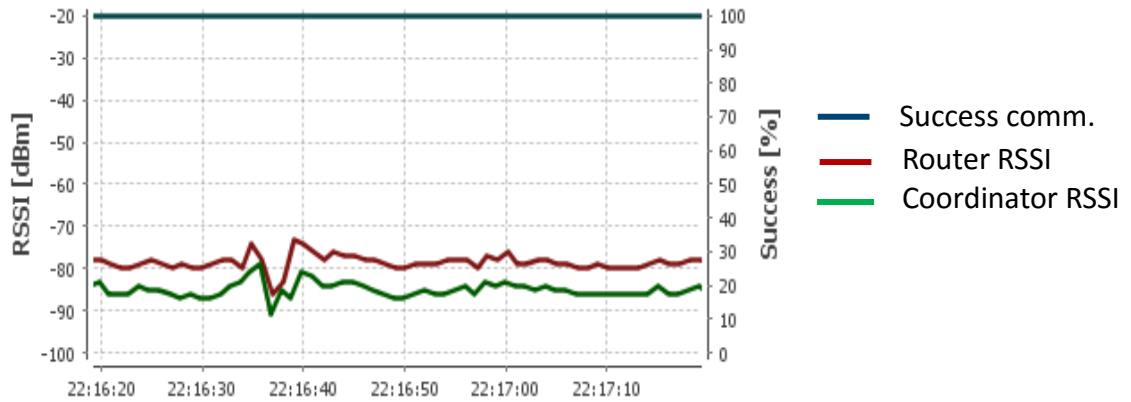

Figure 28 Signal strength at distance of 35 meter

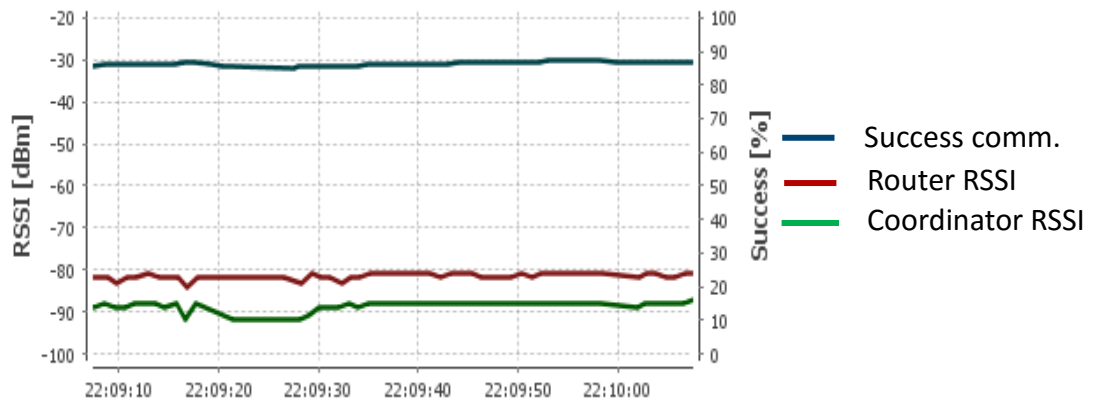

Figure 29 Signal strength at distance of 70 meter

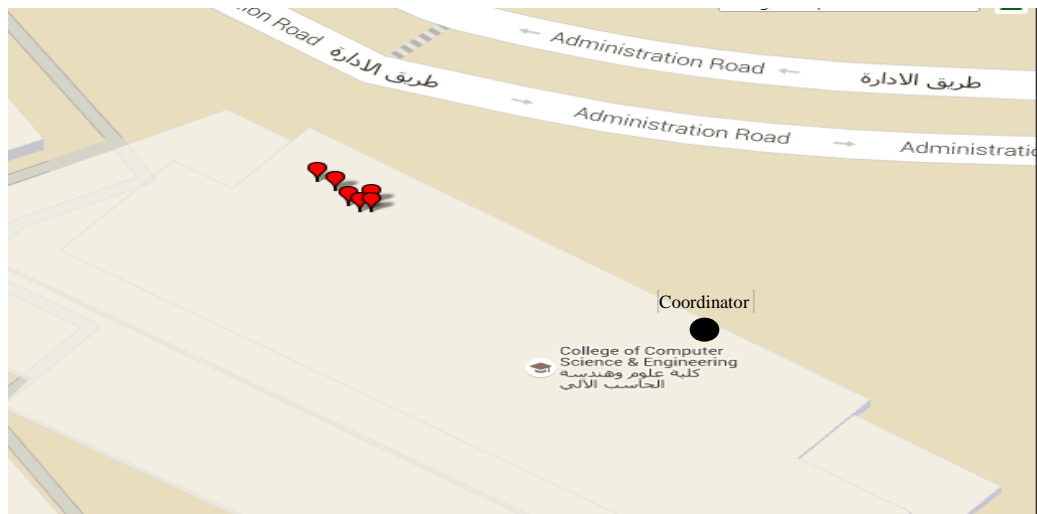

Figure 30 GPS data

The second experiment is conducted in a free space in student housing area. This experiment tests a multi-hop connection where a router node is placed between the coordinator and the sensor node. The router node is approximately 55m far from the coordinator and between 50-70m from the sensor node, due to the movements of sensor node. In this experiment, CH₄ is applied to the sensor to prove that the alarm notification system is working properly, which can tell the worker that there is a high level of CH₄ concentration in the air. Figure 31 shows the concentration of CH₄ which remains stable at around 2000 ppm on average at first. Then, when CH₄ is applied to the sensor, it shows significant rise in the concentration of CH₄, which means detection of toxic gas and the sensor starts alarm and turns on CH₄ LED. In addition, Figure 32 illustrates the concentration of CO overtime during this experiment. It shows slightly increase with reference to the time when the CH₄ was applied to the sensor, however it still below the threshold (i.e. 25 ppm and 10000 ppm for CO and CH₄ respectively). Moreover, figure 33 describes the quality of communication of the experiment.

CH4(PPM)

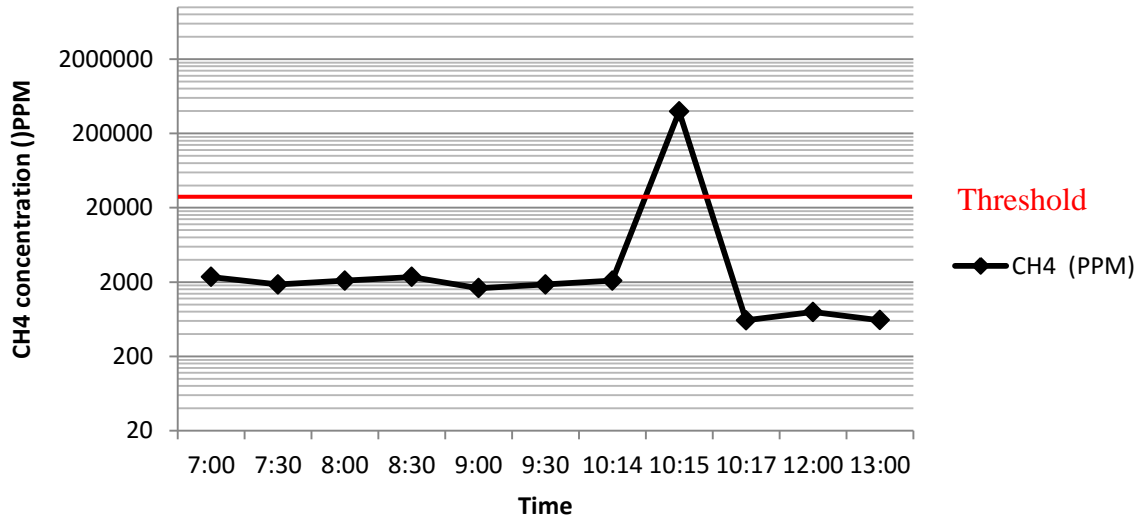

Figure 31 CH4 concentration when it was applied to the sensor

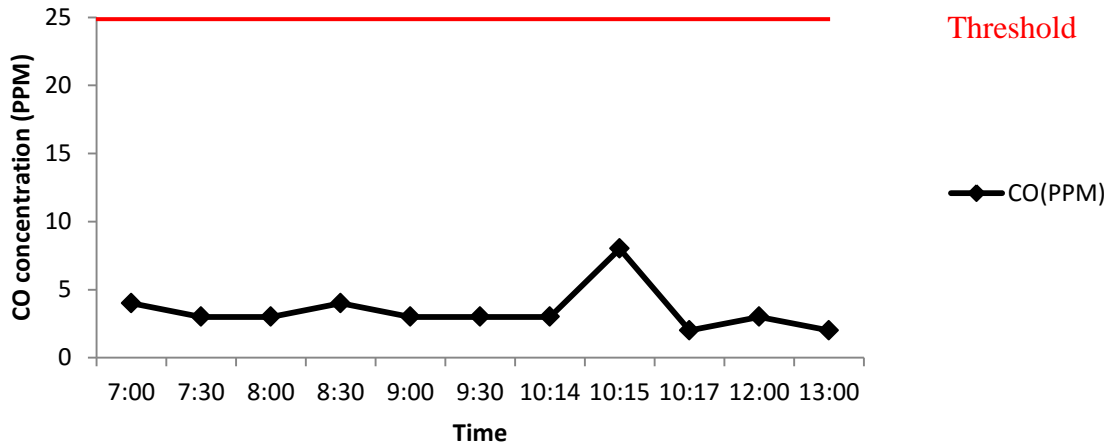

Figure 32 CO concentration when CH4 was applied to the sensor

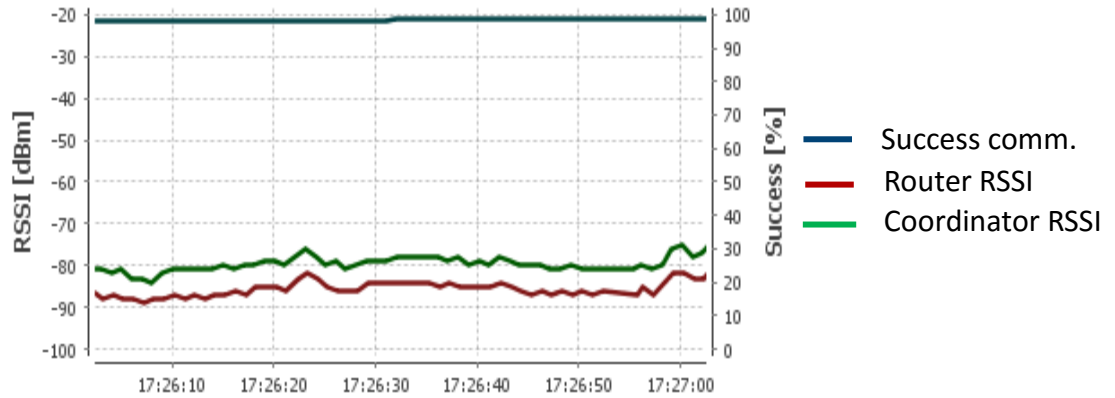

Figure 33 Signal strength between router node and coordinator

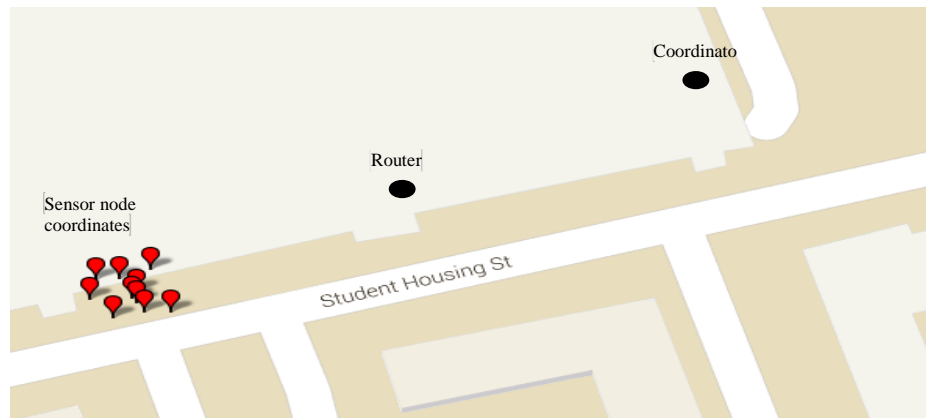

Figure 34 GPS data

In the second experiment the CO was not applied to the sensor node due to its high toxicity. However, because of the sensor node sense the existence of CH₄ it will intuitively detect the existence of CO.

5.3 Power consumption

This experiment investigates power consumption of the sensor node as well as each of its components (Arduino board, Gas sensor, GPS module, Xbee module, and accelerometer). The experiment setup is shown in figure 35. The Agilent oscilloscope [86] was used which provide 100MHz sampling resolution. A one ohm resistance was connected in

series with the sensor node in order to measure current because the current pass through the resistance is proportional to the voltage dropped across the resistance. While the gas sensor heating needs 60 secs of high voltage and 90 secs of low voltage, a sleep period of 60 secs, listening period of 30 secs, and wake up period of one minute were chosen to accommodate sensor's standard operation conditions. However this duty cycle can change depending on the gas detection and the movement of sensor. If there is gas detection, the sensor check and decide to either take another readings if sensor move or go to sleep if it is in the same place.

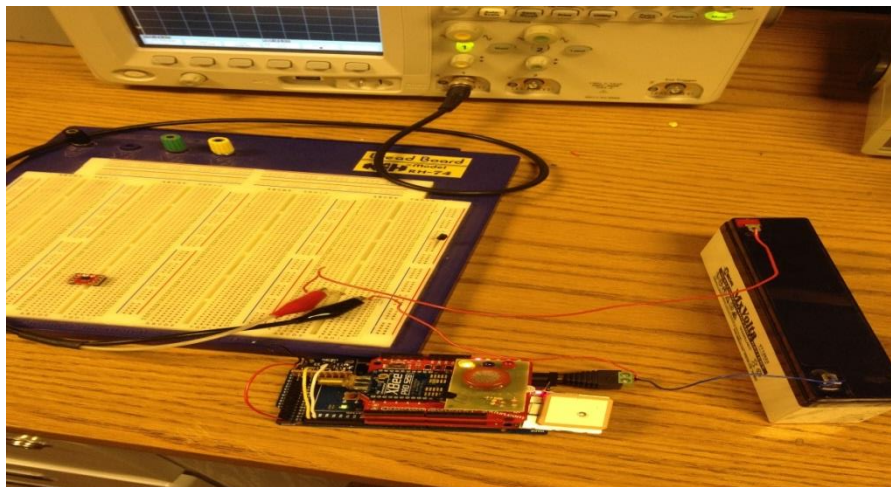

Figure 35 Experiment setup of end node power consumption

The power consumption of the sensor node during a wake up period is around 1.6W (320mA). To further investigate the extent of energy consumption of the key components of the sensor (Arduino board, Gas sensor, GPS module, Xbee module, and accelerometer) each component is examined alone. Then all components are investigated together when each of them is switched on as shown in figure 41.

Figure 36 shows the power consumption of Arduino in sleep mode which consume around 30 mA and wake mode with 89 mA. Xbee module in figure 37 consumes around 51 mA in a listening mode and 55mA in transmitting mode whereas GPS module operates with about 40 mA illustrated in figure 38. Two states for heating MQ-7 sensor, low heating voltage and high heating voltage which uses 48 mA and 140 mA respectively shown in figure 39. The least power hungry module is accelerometer. It can only take 1.9 mA (figure 40). Without using the accelerometer, the sensor will keep sends data and consumes power by switching on the gas sensor and GPS module when the sensor in a static state. However, accelerometer can postpone acquiring data from gas sensor and GPS module and instead it switches them off for a while and sets a timer. Then the sensor node returns back to the listening state. When the timer is finished, the sensor node starts gas sensor and GPS module and collects data.

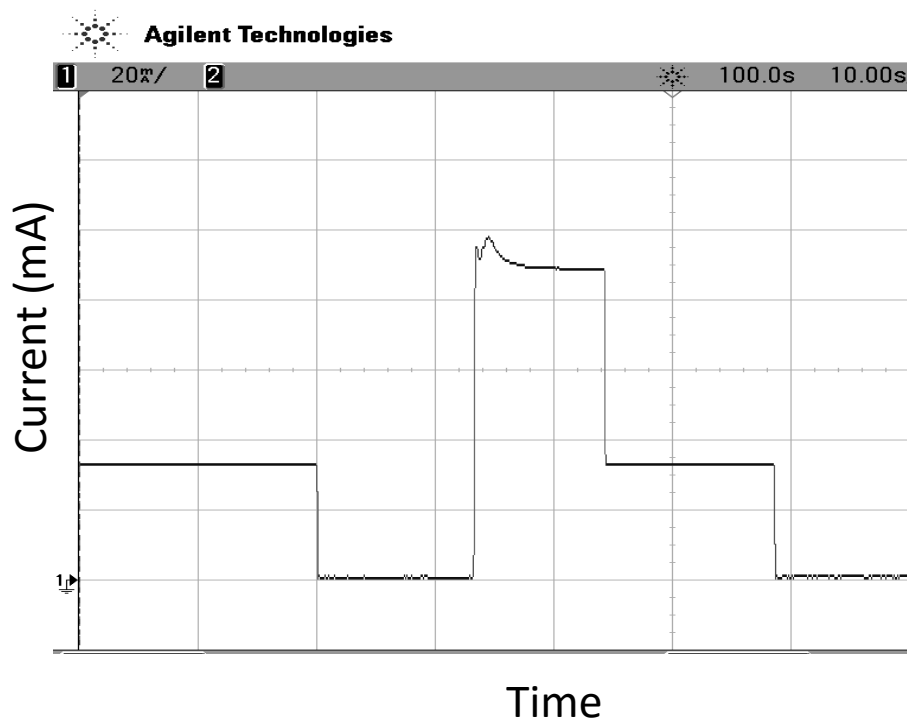

Figure 36 Arduino power consumption in sleep and wake modes

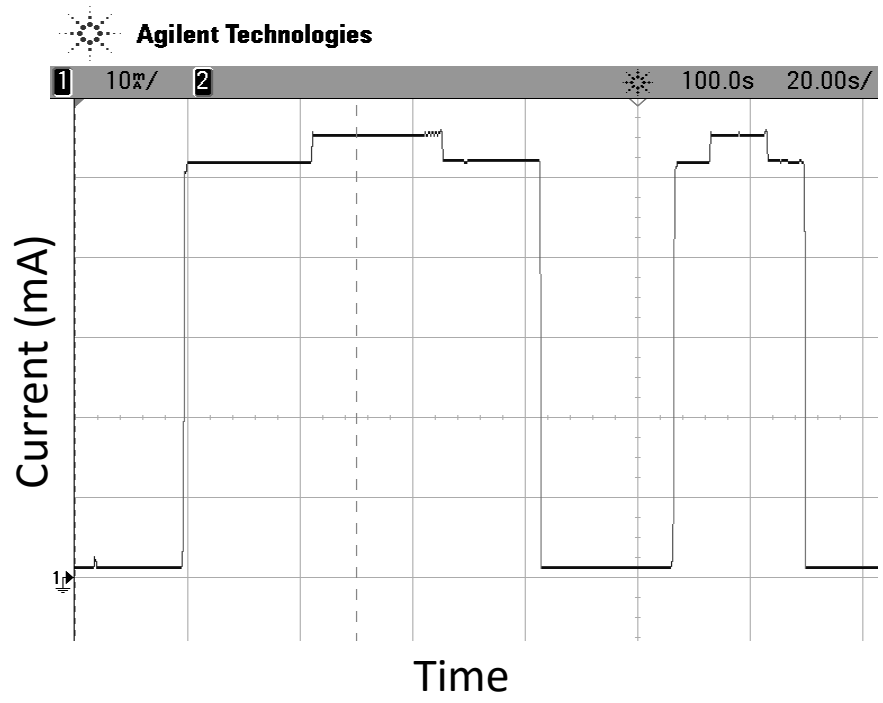

Figure 37 Xbee module power consumption in listening and transmitting mode

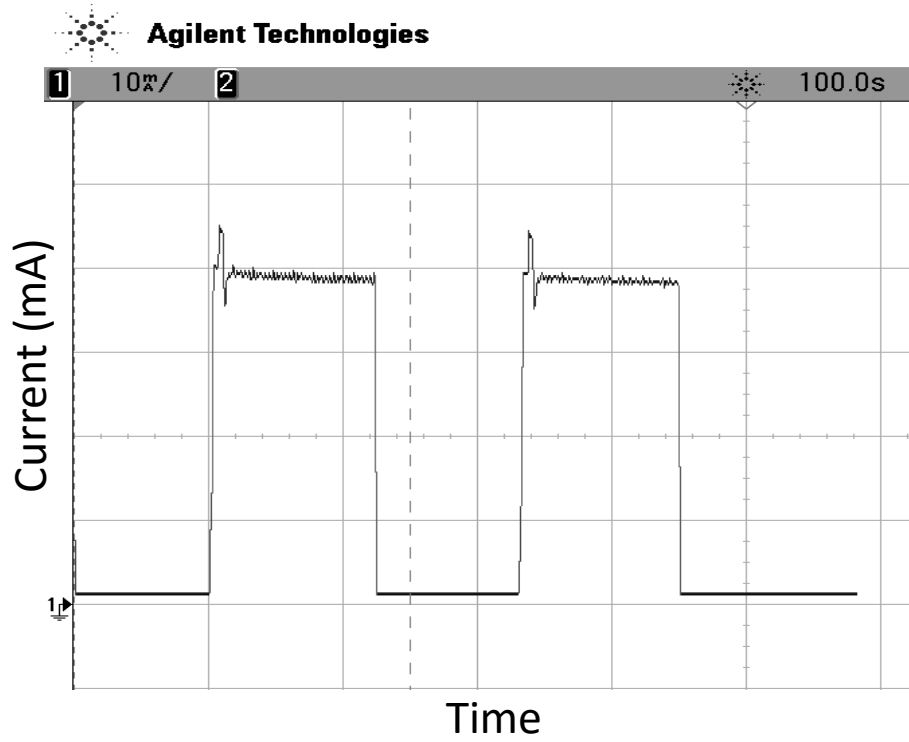

Figure 38 GPS module power consumption

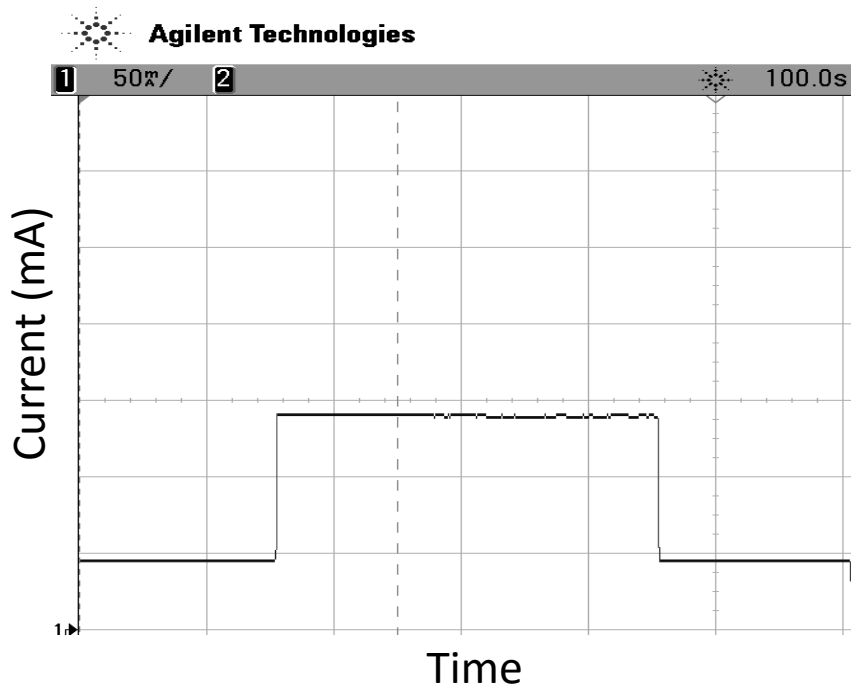

Figure 39 MQ-7 power consumption in low heating and high heating voltage

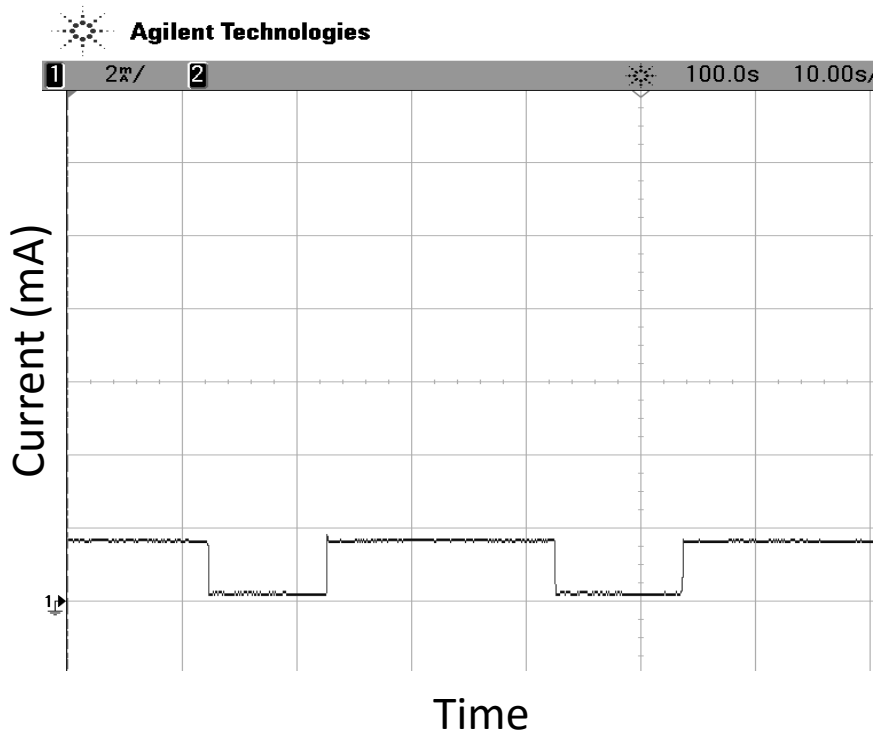

Figure 40 Accelerometer power consumption

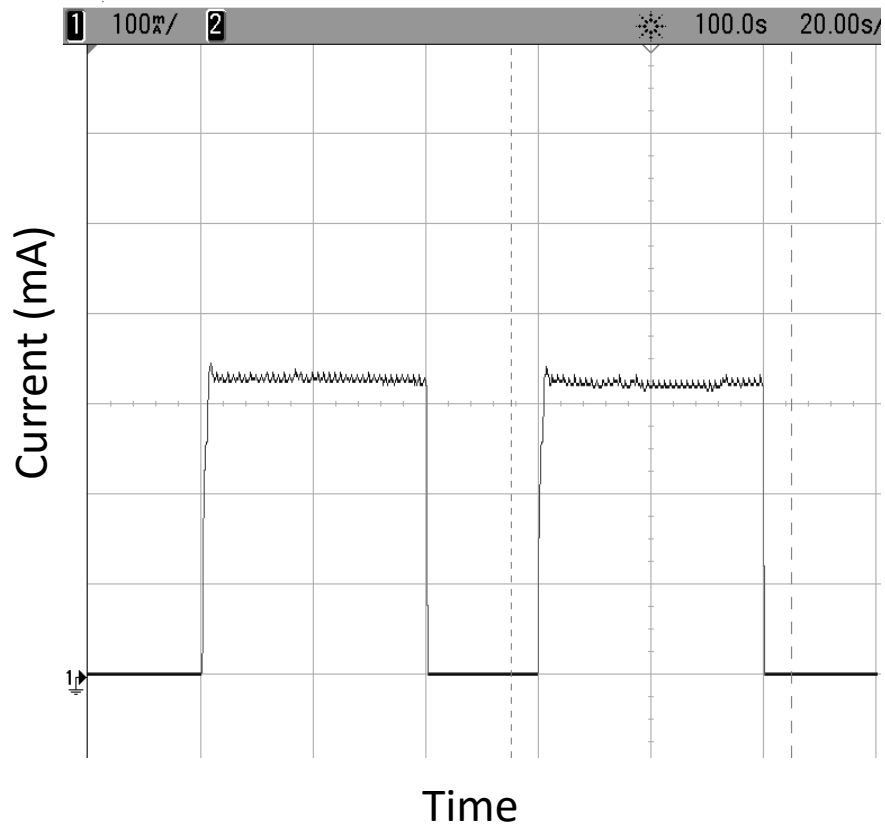

Figure 41 wake up state of all components of sensor node

CHAPTER 6

CONCLUSION

6.1 Conclusion

This research developed a wearable gas sensor network that overcomes the come of the challenges of implementing an inexpensive, low maintenance, and rapidly responding network to measure several toxic gases (i.e. CO and CH₄). The system consists of sensor nodes, routers, and a coordinator. Firstly, a sensor node is an end node responsible for sensing the environment. It activates an alarm when toxic gas in the site is more than a threshold and sends the data to the coordinator. In addition, sensor node adapts the movement of worker. In other words, the sensor node sends more frequent packets about the location than in static state. Secondly a router node is used to relay data from one node to another. Lastly a coordinator node is responsible for collecting data and overseeing the activity of the network.

There are several contributions in this research. First of all, the system can measure the existence of CO and CH₄ around workers and send notifications to others through the coordinator. Second, the MQ-7 is used to sense CO and CH₄ instead of CO only. Last, an effective power system of sensor node to reduce the power consumption by using accelerometer and on demand switching on/off the sensor node components.

The design of the system was presented in chapter 4 by giving details about the system hardware and software. Chapter 5 reports the experiment carried out to test the system. Beside the workability test, the power consumption was tested, which shows the

energy aware of the system. The system is easy to use so that it can compete modern sensors.

6.2 **Future work**

More sensors can be added, such as H₂S, NO, HCl, NO₂, . to make the product more useful in many industries for gas detection.

Web portal creation can be developed in this system in order to make all data available in public domain. This is a reference database for researchers who are working in the field of toxic gases monitoring and also help to increase awareness about gas monitoring among people.

CHAPTER 6

REFERENCES

- [1] W. Dargie and C. Poellabauer, *Fundamentals of Wireless Sensor Networks: Theory and Practice*, 1 edition. Chichester, West Sussex, U.K.; Hoboken, NJ: Wiley, 2010.
- [2] H. Saeed, S. Ali, S. Rashid, S. Qaisar, and E. Felemban, “Reliable monitoring of oil and gas pipelines using wireless sensor network (WSN) #x2014; REMONG,” in *2014 9th International Conference on System of Systems Engineering (SOSE)*, 2014, pp. 230–235.
- [3] M. R. Akhondi, A. Talevski, S. Carlsen, and S. Petersen, “Applications of Wireless Sensor Networks in the Oil, Gas and Resources Industries,” in *2010 24th IEEE International Conference on Advanced Information Networking and Applications (AINA)*, 2010, pp. 941–948.
- [4] A. Willig, K. Matheus, and A. Wolisz, “Wireless Technology in Industrial Networks,” *Proc. IEEE*, vol. 93, no. 6, pp. 1130–1151, Jun. 2005.
- [5] J. A. Bernstein, N. Alexis, C. Barnes, I. L. Bernstein, J. A. Bernstein, A. Nel, D. Peden, D. Diaz-Sanchez, S. M. Tarlo, and P. B. Williams, “Health effects of air pollution,” *J. Allergy Clin. Immunol.*, vol. 114, no. 5, pp. 1116–1123, Nov. 2004.
- [6] B. Brunekreef and S. T. Holgate, “Air pollution and health,” *Lancet Lond. Engl.*, vol. 360, no. 9341, pp. 1233–1242, Oct. 2002.
- [7] H. Heimann, “Effects of air pollution on human health,” *Air Pollut.*, vol. 159, 1961.

- [8] F. Jian and L. Wei, "Harmful Gases Wireless Network Monitoring System Design," in *2014 International Symposium on Computer, Consumer and Control (IS3C)*, 2014, pp. 551–553.
- [9] C. Hou, J. Li, D. Huo, X. Luo, J. Dong, M. Yang, and X. Shi, "A portable embedded toxic gas detection device based on a cross-responsive sensor array," *Sens. Actuators B Chem.*, vol. 161, no. 1, pp. 244–250, Jan. 2012.
- [10] L. Buryakovsky, N. A. Eremenko, M. V. Gorfunkel, and G. V. Chilingarian, *Geology and Geochemistry of Oil and Gas*. Elsevier, 2005.
- [11] A. Bakas and R. Creemers, *Living Without Oil: The New Energy Economy Revealed*. Infinite Ideas, 2010.
- [12] C. Ngo and J. Natowitz, *Our Energy Future: Resources, Alternatives and the Environment*. John Wiley & Sons, 2012.
- [13] "Refinery blast at Exxon facility in Torrance, Calif., injures 4," *Mail Online*. [Online]. Available: <http://www.dailymail.co.uk/news/article-2959036/Refinery-blast-Exxon-refinery-Torrance-Calif-injures-3.html>. [Accessed: 29-Aug-2015].
- [14] A. Hopkins, "Management walk-arounds: Lessons from the Gulf of Mexico oil well blowout," *Saf. Sci.*, vol. 49, no. 10, pp. 1421–1425, Dec. 2011.
- [15] "mocando-well_lessons_2011.pdf." [Online]. Available: https://docs.google.com/viewer?url=http%3A%2F%2Fdocs.lib.noaa.gov%2Fnoaa_documents%2FNNOAA_related_docs%2Foil_spills%2Fmocando-well_lessons_2011.pdf. [Accessed: 29-Aug-2015].
- [16] "Seven Key Lessons to Prevent Worker Deaths During Hot Work In and Around Tanks - Investigations | the U.S. Chemical Safety Board." [Online]. Available:

- <http://www.csb.gov/seven-key-lessons-to-prevent-worker-deaths-during-hot-work-in-and-around-tanks/>. [Accessed: 29-Aug-2015].
- [17] “About the CSB, History | the U.S. Chemical Safety Board.” [Online]. Available: <http://www.csb.gov/about-the-csb/>. [Accessed: 29-Aug-2015].
- [18] “About OSHA Page.” [Online]. Available: <https://www.osha.gov/about.html>. [Accessed: 29-Aug-2015].
- [19] J. Smulko, M. Trawka, C. G. Granqvist, R. Ionescu, F. E. Annanouch, E. Llobet, and L. B. Kish, “New approaches for improving selectivity and sensitivity of resistive gas sensors: A review,” in *8th International Conference on Sensing Technology (ICST 2014), Liverpool, UK, 2-4 September, 2014*, pp. 1–6.
- [20] A. Somov, A. Baranov, A. Savkin, M. Ivanov, L. Calliari, R. Passerone, E. Karpov, and A. Suchkov, “Energy-Aware Gas Sensing Using Wireless Sensor Networks,” in *Proceedings of the 9th European Conference on Wireless Sensor Networks*, Berlin, Heidelberg, 2012, pp. 245–260.
- [21] M. Shanmugaraj, C. M. Ramya, and R. Prabakaran, “Industrial Monitoring Using Zigbee Network,” in *Computer Networks and Information Technologies*, V. V. Das, J. Stephen, and Y. Chaba, Eds. Springer Berlin Heidelberg, 2011, pp. 663–665.
- [22] S. C. Mukhopadhyay, “Wearable Sensors for Human Activity Monitoring: A Review,” *IEEE Sens. J.*, vol. 15, no. 3, pp. 1321–1330, Mar. 2015.
- [23] M. M. Alam and E. B. Hamida, “Surveying Wearable Human Assistive Technology for Life and Safety Critical Applications: Standards, Challenges and Opportunities,” *Sensors*, vol. 14, no. 5, pp. 9153–9209, May 2014.

- [24] M. M. Rodgers, V. M. Pai, and R. S. Conroy, "Recent Advances in Wearable Sensors for Health Monitoring," *IEEE Sens. J.*, vol. PP, no. 99, pp. 1–1, 2014.
- [25] H. Li, X. Mu, Y. Yang, and A. J. Mason, "Low Power Multimode Electrochemical Gas Sensor Array System for Wearable Health and Safety Monitoring," *IEEE Sens. J.*, vol. 14, no. 10, pp. 3391–3399, Oct. 2014.
- [26] M. M. Mahmud, J. Li, J. E. Lunsford, X. Zhang, F. Y. Yamaner, H. T. Nagle, and O. Oralkan, "A low-power gas sensor for environmental monitoring using a capacitive micromachined ultrasonic transducer," in *2014 IEEE SENSORS*, 2014, pp. 677–680.
- [27] R. Sindhuja, K. Sivadhivya, and J. S. Sadiq, "Vitality of sensors in life saving technique of mine workers," in *2014 International Conference on Advanced Communication Control and Computing Technologies (ICACCCT)*, 2014, pp. 935–939.
- [28] J. B. Forsyth, T. L. Martin, D. Young-Corbett, and E. Dorsa, "Feasibility of Intelligent Monitoring of Construction Workers for Carbon Monoxide Poisoning," *IEEE Trans. Autom. Sci. Eng.*, vol. 9, no. 3, pp. 505–515, Jul. 2012.
- [29] N. Nikzad, N. Verma, C. Ziftci, E. Bales, N. Quick, P. Zappi, K. Patrick, S. Dasgupta, I. Krueger, T. Š. Rosing, and W. G. Griswold, "CitiSense: Improving Geospatial Environmental Assessment of Air Quality Using a Wireless Personal Exposure Monitoring System," in *Proceedings of the Conference on Wireless Health*, New York, NY, USA, 2012, pp. 11:1–11:8.
- [30] A. de Nazelle, E. Seto, D. Donaire-Gonzalez, M. Mendez, J. Matamala, M. J. Nieuwenhuijsen, and M. Jerrett, "Improving estimates of air pollution exposure

- through ubiquitous sensing technologies,” *Environ. Pollut.*, vol. 176, pp. 92–99, May 2013.
- [31] R. R. Fletcher, N. M. Oreskovic, and A. I. Robinson, “Design and clinical feasibility of personal wearable monitor for measurement of activity and environmental exposure,” in *2014 36th Annual International Conference of the IEEE Engineering in Medicine and Biology Society (EMBC)*, 2014, pp. 874–877.
- [32] K. Hu, T. Davison, A. Rahman, and V. Sivaraman, “Air Pollution Exposure Estimation and Finding Association with Human Activity Using Wearable Sensor Network,” in *Proceedings of the MLSDA 2014 2Nd Workshop on Machine Learning for Sensory Data Analysis*, New York, NY, USA, 2014, pp. 48:48–48:55.
- [33] K. Heurtefeux, E. Ben Hamida, and H. Menouar, “Design and Implementation of a Sustainable Wireless BAN Platform for Remote Monitoring of Workers Health Care in Harsh Environments,” in *2014 6th International Conference on New Technologies, Mobility and Security (NTMS)*, 2014, pp. 1–5.
- [34] “Shimmer,” 2015. [Online]. Available: <http://www.shimmersensing.com/>.
- [35] “beagleboard XM.” [Online]. Available: <http://beagleboard.org/hardware-xm>.
- [36] Z. Wang and Z. Huang, “Wearable health status monitoring device for electricity workers using ZigBee-based wireless sensor network,” in *2014 7th International Conference on Biomedical Engineering and Informatics (BMEI)*, 2014, pp. 602–606.
- [37] L. Senyurek, K. Hocaoglu, B. Sezer, and O. Urhan, “Monitoring workers through wearable transceivers for improving work safety,” in *2011 IEEE 7th International Symposium on Intelligent Signal Processing (WISP)*, 2011, pp. 1–3.

- [38] G. Manes, G. Collodi, R. Fusco, L. Gelpi, and A. Manes, "A Wireless Sensor Network for Precise Volatile Organic Compound Monitoring," *Int. J. Distrib. Sens. Netw.*, vol. 2012, p. e820716, Apr. 2012.
- [39] G. Manes, G. Collodi, R. Fusco, L. Gelpi, and A. Manes, "Continuous Remote Monitoring in Hazardous Sites Using Sensor Technologies," *Int. J. Distrib. Sens. Netw.*, vol. 2012, p. e317020, Jul. 2012.
- [40] M. I. Mead, O. A. M. Popoola, G. B. Stewart, P. Landshoff, M. Calleja, M. Hayes, J. J. Baldovi, M. W. McLeod, T. F. Hodgson, J. Dicks, A. Lewis, J. Cohen, R. Baron, J. R. Saffell, and R. L. Jones, "The use of electrochemical sensors for monitoring urban air quality in low-cost, high-density networks," *Atmos. Environ.*, vol. 70, pp. 186–203, May 2013.
- [41] M. KhaledHossain, S. M. Ariful Haque, and S. Bhattacharyya, "GSM based Wireless Sensor Network to Measure Global Warming, Humidity and CO₂," *Int. J. Comput. Appl.*, vol. 76, no. 14, pp. 23–29, Aug. 2013.
- [42] *Getting Started with Arduino*. O'Reilly Media.
- [43] S. Manna, S. S. Bhunia, and N. Mukherjee, "Vehicular pollution monitoring using IoT," in *Recent Advances and Innovations in Engineering (ICRAIE), 2014*, 2014, pp. 1–5.
- [44] S. Metkar, P. Khapare, and A. Palve, "Web Enabled Remote Toxic Gas Monitoring and Controlling System," *Int. J. Comput. Appl.*, vol. 90, no. 9, 2014.
- [45] "Gas sensors," 2015. [Online]. Available: http://www.futurlec.com/Gas_Sensors.shtml.

- [46] E. Sazonov and M. R. Neuman, *Wearable Sensors: Fundamentals, Implementation and Applications*. Elsevier, 2014.
- [47] P. Salvo, *Wearable technologies for sweat rate and conductivity sensors: design and principles*. Anchor Academic Publishing (aap_verlag), 2013.
- [48] S. Petersen, P. Doyle, S. Vatland, C. S. Aasland, T. M. Andersen, and D. Sjong, “Requirements, drivers and analysis of wireless sensor network solutions for the Oil Gas industry,” in *IEEE Conference on Emerging Technologies and Factory Automation, 2007. ETFA, 2007*, pp. 219–226.
- [49] B. P. Crow, I. Widjaja, J. G. Kim, and P. T. Sakai, “IEEE 802.11 Wireless Local Area Networks,” *IEEE Commun. Mag.*, vol. 35, no. 9, pp. 116–126, Sep. 1997.
- [50] “Approved IEEE Draft Standard for Information Technology– Telecommunications and Information Exchange Between Systems– Local and Metropolitan Area Networks– Specific Requirements Part 15.1Reva: Wireless Medium Access Control (MAC) and Physical Layer (PHY) Specifications for Wireless Personal Area Networks (WPANs) (Replaced by IEEE 802.15.1-2005),” *IEEE Std P802151D6*, 2004.
- [51] “IEEE Standard for Information technology-Telecommunications and information exchange between systems-Local and metropolitan area networks-Specific requirements Part 15.4: Wireless Medium Access Control (MAC) and Physical Layer (PHY) Specifications for Low-Rate Wireless Personal Area Networks (WPANs) Amendment 3: Alternative Physical Layer Extension to support the Japanese 950 MHz bands,” *IEEE Std 802154d-2009 Amend. IEEE Std 802154-2006*, pp. c1–27, Apr. 2009.

- [52] “WirelessHART Technical Notes.” [Online]. Available:
http://en.hartcomm.org/hcp/tech/articles/wiHART_resources/witech_witechnote.html
. [Accessed: 05-Sep-2015].
- [53] “ISA100, Wireless Systems for Automation- ISA.” [Online]. Available:
<https://www.isa.org/isa100/>. [Accessed: 03-Sep-2015].
- [54] N. A. Somani and Y. Patel, “Zigbee: A Low Power Wireless Technology For Industrial Applications,” *Int. J. Control Theory Comput. Model. IJCTCM Vol*, vol. 2, 2012.
- [55] H. Hayashi, T. Hasegawa, and K. Demachi, “Wireless technology for process automation,” in *ICCAS-SICE, 2009*, 2009, pp. 4591–4594.
- [56] R. Zurawski, *Industrial Communication Technology Handbook, Second Edition*. CRC Press, 2014.
- [57] S. F. Singer, Ed., *Global Effects of Environmental Pollution*. Dordrecht: Springer Netherlands, 1970.
- [58] L. S. Jaffe, “Sources, Characteristics, and Fate of Atmospheric Carbon Monoxide,” *Ann. N. Y. Acad. Sci.*, vol. 174, no. 1, pp. 76–88, Oct. 1970.
- [59] “CDC - NIOSH Publications and Products - Criteria for a Recommended Standard: Occupational Exposure to Carbon Monoxide (73-11000).” [Online]. Available: <http://www.cdc.gov/niosh/docs/1970/73-11000.html>. [Accessed: 06-Sep-2015].
- [60] E. N. Ramsden, *A-Level Chemistry*. Nelson Thornes, 2000.
- [61] E. N. Ramsden, *Chemistry of the Environment*. Nelson Thornes, 1996.

- [62] J. Kotz, P. Treichel, J. Townsend, and D. Treichel, *Chemistry & Chemical Reactivity*. Cengage Learning, 2014.
- [63] D. Pavia, G. Lampman, G. Kriz, and J. Vyvyan, *Introduction to Spectroscopy*. Cengage Learning, 2008.
- [64] “Infrared gas analyzer,” *Wikipedia, the free encyclopedia*. 17-Jan-2015.
- [65] H. Bai and G. Shi, “Gas Sensors Based on Conducting Polymers,” *Sensors*, vol. 7, no. 3, pp. 267–307, Mar. 2007.
- [66] “Chemical Sensors: Comprehensive Sensor Technologies Volume 5: Electrochemical and Optical Sensors | Momentum Press.” [Online]. Available: <http://www.momentumpress.net/books/chemical-sensors-comprehensive-sensor-technologies-vol-5-electrochemical-and-optical-sensors>. [Accessed: 07-Sep-2015].
- [67] G. F. Fine, L. M. Cavanagh, A. Afonja, and R. Binions, “Metal Oxide Semiconductor Gas Sensors in Environmental Monitoring,” *Sensors*, vol. 10, no. 6, pp. 5469–5502, Jun. 2010.
- [68] S. K. Kim, D. R. Burris, J. Bryant-Genevier, K. A. Gorder, E. M. Dettenmaier, and E. T. Zellers, “Microfabricated Gas Chromatograph for On-Site Determinations of TCE in Indoor Air Arising from Vapor Intrusion. 2. Spatial/Temporal Monitoring,” *Environ. Sci. Technol.*, vol. 46, no. 11, pp. 6073–6080, Jun. 2012.
- [69] Z. Ouyang and R. G. Cooks, “Miniature Mass Spectrometers,” *Annu. Rev. Anal. Chem.*, vol. 2, no. 1, pp. 187–214, 2009.
- [70] J. Kim, B. Bae, J. Hammonds, T. Kang, and M. A. Shannon, “Development of a micro-flame ionization detector using a diffusion flame,” *Sens. Actuators B Chem.*, vol. 168, pp. 111–117, Jun. 2012.

- [71] W. H. Brattain and J. Bardeen, "Surface Properties of Germanium," *Bell Syst. Tech. J.*, vol. 32, no. 1, pp. 1–41, Jan. 1953.
- [72] T. Seiyama and S. Kagawa, "Study on a Detector for Gaseous Components Using Semiconductive Thin Films.," *Anal. Chem.*, vol. 38, no. 8, pp. 1069–1073, Jul. 1966.
- [73] G. Heiland, "Homogeneous semiconducting gas sensors," *Sens. Actuators*, vol. 2, pp. 343–361, 1981.
- [74] A. Tricoli, M. Righettoni, and A. Teleki, "Semiconductor Gas Sensors: Dry Synthesis and Application," *Angew. Chem. Int. Ed.*, vol. 49, no. 42, pp. 7632–7659, Oct. 2010.
- [75] B. Doyle, *Hazardous Gases Underground: Applications to Tunnel Engineering*. CRC Press, 2001.
- [76] J. A. Ferdousi, S. E. Ananto, and M. N. Ahmed, "Development of Carbon Monoxide detecting device using MQ-7 sensor along with its statistical analysis," Thesis, BRAC University, 2014.
- [77] N. M. Yayavaram, S. Rajan, and V. Vardhan, "ARM Processor Based Multisensor System Design for the Measurement of Environmental Parameters," *Sens. Transducers*, vol. 136, no. 1, pp. 59–71, Jan. 2012.
- [78] "Atmel-2549-8-bit-AVR-Microcontroller-ATmega640-1280-1281-2560-2561_datasheet.pdf." [Online]. Available: https://docs.google.com/viewer?url=http%3A%2F%2Fwww.atmel.com%2FImages%2FAtmel-2549-8-bit-AVR-Microcontroller-ATmega640-1280-1281-2560-2561_datasheet.pdf. [Accessed: 09-Sep-2015].

- [79] “Arduino - ArduinoBoardMega2560.” [Online]. Available:
<https://www.arduino.cc/en/Main/ArduinoBoardMega2560>. [Accessed: 09-Sep-2015].
- [80] “Arduino board schematic.” [Online]. Available:
https://www.arduino.cc/en/uploads/Main/arduino-mega2560_R3-sch.pdf. [Accessed:
08-May-2016].
- [81] “90000976_W.pdf.” [Online]. Available:
https://docs.google.com/viewer?url=http%3A%2F%2Fftp1.digi.com%2Fsupport%2Fdocumentation%2F90000976_W.pdf. [Accessed: 09-Sep-2015].
- [82] “Product Manual: XBee / XBee-PRO ZB RF Modules.” [Online]. Available:
<http://www.digi.com/support/productdetail?pid=4549&type=documentation>.
- [83] “SparkFun XBee Shield - WRL-12847 - SparkFun Electronics.” [Online].
Available: <https://www.sparkfun.com/products/12847>. [Accessed: 09-Sep-2015].
- [84] “Xbee sheild.” [Online]. Available:
<https://www.arduino.cc/en/uploads/Main/XbeeShieldSchematic.pdf>. [Accessed: 08-
May-2016].
- [85] *MQ-7 Datasheet*. [Online]. Available:
<https://www.sparkfun.com/datasheets/Sensors/Biometric/MQ-7.pdf>.
- [86] “DSO5012A 5000 Series Oscilloscope: 100 MHz, 2 channels.” [Online].
Available: <http://cp.literature.agilent.com/litweb/pdf/54695-97015.pdf>.

Vitae

Name : Adel Mohammed Binajjaj

Nationality : Yemeni

Date of Birth : 3/10/1986

Email : a.ajjaj@gmail.com

Address : Hadhramaut, Yemen

Academic Background :M.S in Computer Engineering, April 2016
King Fahd University of Petroleum and Minerals
Dhahran, Saudi Arabia

B.S in Computer Engineering, July 2010
Hadhramaut University for Science and Technology,
Hadhramaut, Republic of Yemen

Publications: M., Farouq, Yahya Osais, Ismail Keshta, and Adel Binajjaj.
“Maximizing Throughput of SW ARQ with Network
coding through Forward Error Correction.” International
Journal of Advanced Computer Science and Applications 6,
no. 6 (2015). doi:10.14569/IJACSA.2015.060640.