

**A WSN BASED PROTOTYPE FOR WATER
CONSERVATION IN A SMART HOME**

BY
MOHAMMED YOUNUS SIDDIQUI

A Thesis Presented to the
DEANSHIP OF GRADUATE STUDIES

KING FAHD UNIVERSITY OF PETROLEUM & MINERALS

DHAHRAN, SAUDI ARABIA

In Partial Fulfillment of the
Requirements for the Degree of

MASTER OF SCIENCE

In

COMPUTER NETWORKS

May, 2015

KING FAHD UNIVERSITY OF PETROLEUM & MINERALS

DHAHRAN- 31261, SAUDI ARABIA

DEANSHIP OF GRADUATE STUDIES

This thesis, written by **Mohammed Younus Siddiqui** under the direction his thesis advisor and approved by his thesis committee, has been presented and accepted by the Dean of Graduate Studies, in partial fulfillment of the requirements for the degree of **MASTER OF SCIENCE IN COMPUTER NETWORKS**.



Dr. Yahya Osais
(Advisor)

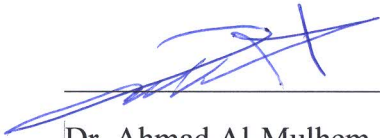

Dr. Ahmad Al-Mulhem
Department Chairman



Dr. Ashraf S. Hasan Mahmoud
(Member)



Dr. Salam A. Zummo
Dean of Graduate Studies



Dr. Jihad Al-Sadah
(Member)

Date

23/5/15

© Mohammed Younus Siddiqui

2015

[To my beloved Mother]

ACKNOWLEDGMENTS

Indeed, all thanks and praise is due to Allah, the Lord of the worlds. We praise Him, repent to Him and seek His forgiveness and help. We seek refuge in Allah from the evil of our own selves and of our wicked deeds. Whomsoever Allah guides, none can lead astray; and whomsoever Allah leads astray, none can guide. And I bear witness that none has the right to be worshiped except Allah alone, and He has no partner; and I bear witness that Muhammed is His slave and Messenger. May Allah's Peace and Blessings be upon our Prophet Muhammad, his pure family, his noble companions, and all those who follow them with righteousness until the Day of Judgment.

I would like to express my gratitude to my thesis advisor Dr. Yahya Osais for his constant support and immense patience. He constantly helped in research and writing of this thesis. I could not have thought of having a better mentor and advisor.

I would like to extend my deepest gratitude to Dr. Jihad Al-Sadah for his guidance and understanding during my research work. I thank him for his insightful comments and generous help in the completion of my thesis. I would also like to thank Dr. Ashraf S. Mahmoud for being in my thesis committee and spending his valuable time in reading and evaluating my thesis.

I am also very thankful to my friends at KFUPM who have helped through these years. Special mention goes out to Tayyab and Razi for their tremendous help when I needed it the most. Thank you for your encouragement, support and most importantly your company.

Last, but not the least, I would also like to thank my parents for taking care of me, for their unconditional support and instilling in me admirable qualities. It was only due to my mother's desire and continuous insistence that I decided to get a master's degree. I am forever indebted to them. May Allah bestow mercy on them as they took care of me when I was little.]

TABLE OF CONTENTS

ACKNOWLEDGMENTS	V
TABLE OF CONTENTS	VII
LIST OF TABLES	X
LIST OF FIGURES	XI
LIST OF ABBREVIATIONS	XIII
ABSTRACT	XV
ARABIC ABSTRACT	XVI
CHAPTER 1 INTRODUCTION	1
1.1 Water Scarcity	1
1.2 Wireless Sensor Networks	3
1.3 Cyber Physical System	4
1.4 Internet of Things	5
1.5 Applications of CPS and IoT in Water Conservation	5
1.6 Problem Statement	7
1.7 Thesis Objectives	7
1.8 Contribution	8
1.9 Organization of Thesis	8
CHAPTER 2 LITERATURE REVIEW	9
2.1 Water Monitoring System	9
2.2 Water-Based Activity Sensing Systems	11

2.3	Water/Energy Conservation Systems	15
2.4	On-Demand Hot Water Recirculation.....	16
CHAPTER 3 SYSTEM DESIGN		17
3.1	Thermal Rejection System Design	18
3.1.1	Tank-less System	20
3.1.2	Tank-based System.....	22
3.1.3	Winter Operation	23
3.1.4	Summer Operation.....	24
CHAPTER 4 HARDWARE		26
4.1	Arduino.....	26
4.2	Arduino MEGA 2560.....	28
4.3	ZigBee	29
4.4	XBEE-PRO.....	32
4.5	XBEE Shield	34
4.6	XBEE Explorer.....	35
4.7	Flow Meter	37
4.8	Solenoid Valve	38
4.9	Relay Board.....	40
4.10	Temperature Sensor	41
CHAPTER 5 PROTOTYPE AND EXPERIMENTAL RESULTS.....		43
5.1	Tank-less Physical Setup	43
5.2	Tank-based Physical Setup	45
5.3	Tank-less Experimental Results	46
5.4	Tank-based Experimental Results	49

5.5 Water Saving Estimation	51
CHAPTER 6 CONCLUSION AND FUTURE WORK	54
APPENDIX A IMAGES OF THE BUILT PROTOTYPE	56
APPENDIX B ARDUINO CODE	78
B.1 Front Box	78
B.2 Back Box.....	87
REFERENCES.....	99
VITAE	102

LIST OF TABLES

Table 4-1: Specification of Arduino Mega 2560	29
Table 4-2: XBEE-PRO Module Specification	33
Table 4-3: XBEE Shield's LED Functions	35
Table 4-4: Specifications of the Solenoid Valves	40
Table 5-1: Water Saving Estimates.....	53

LIST OF FIGURES

Figure 1-1: Total Annual Renewable Water Resources by Country	2
Figure 3-1: Traditional WDN	18
Figure 3-2: HWR with pump	19
Figure 3-3: On-demand HWR	20
Figure 3-4: Tank-less System - Normal Operation.....	21
Figure 3-5: Tank-less System – Thermal Rejection Operation	22
Figure 3-6: Tank System: Normal Operation	23
Figure 3-7: Tank System - Winter Operation	24
Figure 3-8: Tank Operation - Summer Mode	25
Figure 4-1: Registered Logo of Arduino	27
Figure 4-2: Arduino Mega 2560 R3 Front.....	28
Figure 4-3: Various Application of ZigBee.....	30
Figure 4-4: Various ZigBee Topologies	32
Figure 4-5: XBEE-PRO RF Module.....	32
Figure 4-6: XBEE Shield without pin headers	34
Figure 4-7: XBEE Explorer	36
Figure 4-8: XBEE Explorer with XBEE RF Module	36
Figure 4-9: Pinwheel Flow Meter	37
Figure 4-10: Operation of a Normally Closed Solenoid Valve	38
Figure 4-11: Brass Solenoid Valve	39
Figure 4-12: Plastic Solenoid Valve	39
Figure 4-13: 4-Channel Relay Board.....	41
Figure 4-14: 8-Channel Relay Board.....	41
Figure 4-15: Waterproof Temperature Sensor.....	42
Figure 5-1: Layout Design of the Prototype	44
Figure 5-2. Layout of Tank-based Prototype.....	45
Figure 5-3: Temperature variation at the sensors during the thermal rejection process...	47
Figure 5-4: Flow rate during Thermal Rejection Process.....	48
Figure 5-5: Total Amount of water saved during the thermal rejection process	48
Figure 5-6: Temperature variation during Winter Mode Operation	50
Figure 5-7: Flow Rate in the Rejection Line during Winter Mode Operation.....	51
Figure 5-8: Amount of Water sent back to the Tank during Winter Mode Operation	51
Figure 5-9: Climate Data for Dhahran	52
Figure 5-10: Average number of showers versus the number of residents per home	53
Figure A-1: 64L Container as the Water Source	57
Figure A-2: Connection Leading from the Container to the Supply Pump	58
Figure A-3: Water Supply Mains Pump	59
Figure A-4: Solenoid Valve places after the Mains.....	60

Figure A-5: One Way Valve on the Supply line to Heater	61
Figure A-6: Hot Water Supply Line	62
Figure A-7: Heater's Inlet (Blue) and Outlet (Red)	63
Figure A-8: Temperature Sensor Attached at Heater's Outlet	64
Figure A-9: Front View of the Water Heater	65
Figure A-10: Heater's Outlet connects to the 25m pipe inside the Orange Container	66
Figure A-11: Solenoid Valve at the User's End	67
Figure A-12: Temperature Sensor at the User's End	68
Figure A-13: One Way Valve on the Reject Loop	69
Figure A-14: Top View of the Reject Loop with Solenoid Valve and Reject Pump.....	70
Figure A-15: Flow Meter installed on the outlet of the Reject Pump.....	71
Figure A-16: Side View of the Prototype	72
Figure A-17: Solenoid Valve and TEE on the cold line	73
Figure A-18: Reject Line to the Tank containing a Solenoid Valve and a Flow Meter ...	74
Figure A-19: Front Box with Arduino MEGA, XBEE PRO, RELAY and BUTTON.....	75
Figure A-20: Back Box with Arduino Mega and XBEE PRO	76
Figure A-21: Relay Board connected to Back Box	77

LIST OF ABBREVIATIONS

CIT	:	Communication and Information Technology
CPS	:	Cyber Physical Systems
HWR	:	Hot Water Recirculation
IDE	:	Integrated Development Environment
IEEE	:	Institute of Electrical and Electronics Engineers
IoT	:	Internet of Things
LCD	:	Liquid Crystal Display
LED	:	Light-Emitting Diodes
MOSFET	:	Metal–Oxide–Semiconductor Field-Effect Transistor
PAN	:	Personal Area Network
PSI	:	Pounds per Square Inch
PVC	:	Polyvinyl Chloride
PWM	:	Pulse Width Modulation
QoS	:	Quality of Service
RF	:	Radio Frequency
RSSI	:	Received Signal Strength Indication

UART	:	Universal Asynchronous Receiver/Transmitter
USB	:	Universal Serial Bus
WDN	:	Water Delivery Network
WSN	:	Wireless Sensor Network

ABSTRACT

Full Name : Mohammed Younus Siddiqui
Thesis Title : A WSN Based Prototype for Water Conservation in a Smart Home
Major Field : Computer Networks
Date of Degree : May, 2015

Dwindling fresh water supplies and growing demands compel us to find ways to conserve water. One opportunity to conserve is saving thermally rejected water. When water running through pipes is either too cold or too hot for comfortable or safe use, it is let down the drain until desired temperature water arrives to the user. This water is perfectly clean but wasted due to its temperature. This process of thermal rejection is repeated several times during a typical winter day. In this thesis, we propose an innovative solution that uses a wireless sensor network on top of the home water distribution network to create an intelligent cyber physical system which can be used for water as well as energy saving. The newly proposed system saves water by thermally rejecting unfit water back into the system along the other line until water at a comfortable temperature arrives. A working prototype is built using Arduino microcontroller and solenoid valves. Two different designs of the rejection process were implemented. Experimental results show significant water savings by the proposed system.

ARABIC ABSTRACT

ملخص الرسالة

الاسم الكامل: محمد يونس صديقي

عنوان الرسالة: نموذج حفظ المياه في المنازل الذكية باستخدام شبكة الاستشعار اللاسلكية

التخصص: شبكات الحاسوب

تاريخ الدرجة العلمية: مايو 2015

تضاؤل إمدادات المياه العذبة، وتزايد المطالب عليها تدفعنا إلى البحث عن سبل الحفاظ على المياه. إحدى الفرص للمحافظة على المياه العذبة هي حفظ المياه المرفوضة حرارياً. عندما تمر تلك المياه من خلال الأنابيب تكون إما مياه باردة جداً أو ساخنة جداً نسبة للاستخدام مناسب وآمن. الطريقة المعتادة لحل هذه المشكلة هي ترك الماء ينسكب حتى يصل لدرجة الحرارة المطلوبة لمستخدمه. هذه المياه نظيفة تماماً ولكن تهدر بسبب ارتفاع درجة حرارتها. يتم تكرار عملية الهدر هذه عدة مرات يومياً خصوصاً خلال فصل شتاء. في هذه الأطروحة، قمنا باقتراح حلاً مبتكراً يستخدم شبكة استشعار لاسلكية على رأس شبكة توزيع المياه المنزلية لإنشاء نظام سايبير ذكي يساهم في حفظ استهلاك المياه والطاقة. النظام الجديد المقترح يقوم برد المياه غير صالحة حرارياً بالمرور إلى النظام حتى تصل المياه إلى درجة حرارة مناسبة للمستخدم. تم بناء نموذج متكامل باستخدام متحكم اردوينو والملف اللولبي الصمامات. وتم القيام بتنفيذ تصميمين مختلفين من عملية النموذج. إظهرت نتائج التجارب توفير كمية كبيرة من المياه نتيجة لاستخدام النظام المقترح.

CHAPTER 1

INTRODUCTION

Water is a natural resource on which all lifeforms depend on. The ever increasing demand has decreased the supply of available fresh water. Water scarcity has become a prominent issue across the world. Hence, water conservation should be the prerequisite for any intelligent water control and monitoring system. Water is typically wasted in homes when it is either too hot or too cold for comfortable use. This perfectly clean water is wasted down the drain until water of desired temperature arrives. The main objective of this thesis is to propose and implement a new water conservation system for home which is highly efficient and provides the user with the specified temperature.

1.1 Water Scarcity

Water is the need of every living organism on the earth. It is an essential natural resource on which the world's economic and social functions depend. By 2050, the world population is expected to grow to 9.1 billion [1]. This unprecedented growth in population has led to an ever-increasing demand for fresh water. Seawater constitutes 97% of available water but it is too salty either for consumption or agricultural use. Hence, only a small portion of the available water is useable. Most of the usable water is either trapped in ice caps or is present in unattainable sources.

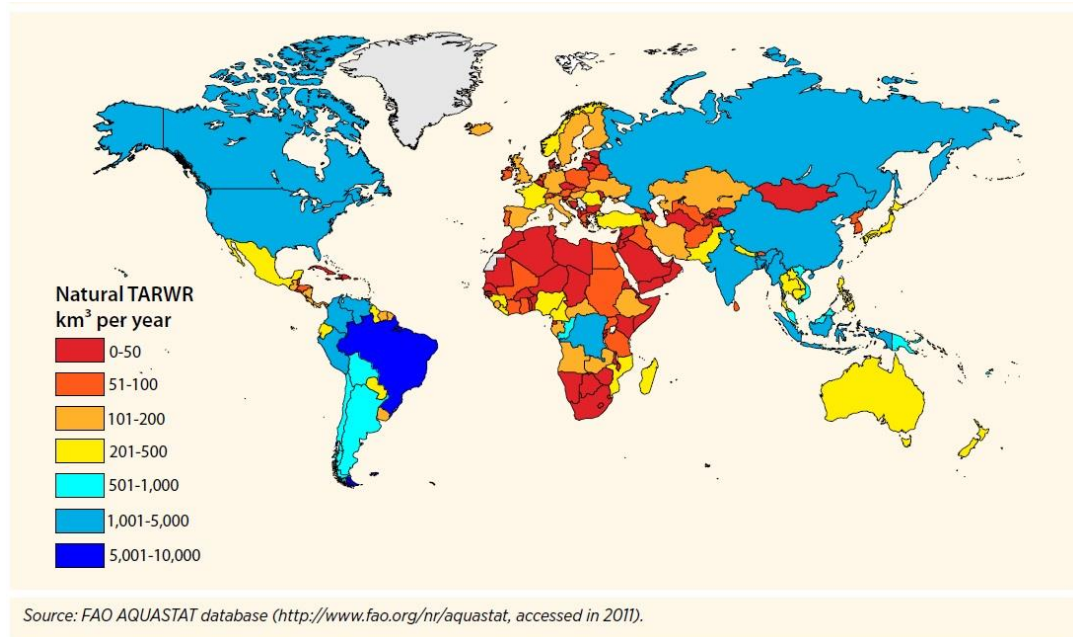

Figure 1-1: Total Annual Renewable Water Resources by Country

Saudi Arabia is one of the most water scarce countries in the world; see Figure 1-1. It has no perennial rivers or permanent water bodies and receives a very low annual rainfall. The main sources of useable water in Saudi Arabia are desalinated seawater and underground water. As for the underground water, it is receding at an alarming rate and most of it has already been depleted. This is due to the population in the Arab region which has increased by 43% in past two decades [2]. Water consumption due to household in Saudi Arabia is more than eight million cubic meter per day and this demand is increasing by 7.5% annually [3]. The receding underground water meets the 40% of water demand and the rest is met by desalinating seawater. The cost of desalinating seawater is 1-2\$/m³ which is likely to increase as the price of the fossil energy increases. The desalination process as it stands is

not sustainable in the near future due to the ever-increasing demand and increasing cost per unit of desalinated water. An efficient water saving measures using Communication and Information Technology (CIT) should be seriously considered. Wireless Sensor Networks (WSNs) could be one such tool for conserving water.

1.2 Wireless Sensor Networks

In the recent years, there have been significant technological advances in the creation of low cost sensors which have enabled easy deployment of ubiquitous communication everywhere. A Wireless Sensor Network (WSN) is defined as a network which consists of small low powered sensors which can be used to sense environmental characteristics such as light, temperature, sound and motion. The sensors are used to collect data in real time and they can communicate with each other wirelessly. The data collected is then sent to a base station sensor known as the sink using a multi hop routing protocol. WSNs can be deployed indoor and outdoor, and can also be fixed or mobile. The applications of WSN are numerous and diverse ranging from military operations [4], medical health monitoring [5], real time industrial monitoring [6], and environmental monitoring [7]. Extensive research on WSN have played a key role in the development of Cyber Physical System (CPS) and Internet of Things (IoT). Wireless sensors are used in our thermal rejection systems.

1.3 Cyber Physical System

The term CPS was first used by Helen Gill to refer to the integration of physical system with computation system at the National Science Foundation in 2006 [8]. A CPS consists of sensors, network embedded controllers and actuators which make any physical system that adapts itself according to the system's state and its interaction with humans. An actuator is a device, which is used to alter a physical quantity and is controlled by a voltage input. The sensors monitor the physical layer and periodically collect information about the physical layer. This information is also periodically sent to the software/computation layer where it is analyzed and a decision is made about the state of the physical layer. The actuators/controllers then change the state of the physical layer based on the input from the software layer. Thus, the two layers form a feedback loop where the computations affect the physical state and vice versa.

Designing a CPS requires one to have understanding of the physical process, wireless sensor and networks; and the dynamics of joining the two layers. It is the intersection of these layers not the union that sets CPS apart from other systems. Recently CPS are often packaged with network interfaces which allows them to be a part of the internet. It is this trend of connecting the physical world with the information world using CPS and internet that has given rise to IoT. Our thermal rejection system can be classified as a cyber-physical system because it involves sensing and actuation based on the sensed data.

1.4 Internet of Things

IoT is an innovative vision in which everyday objects are interconnected to each other and the internet using latest communication technologies. The “thing” in IoT can be a man-made or naturally occurring object, living or nonliving thing such as human with a heart implant or a car with a tire pressure sensor. Any “thing” can be a part of IoT as long as it has a uniquely identifiable IP address and is connected to any network. This has been made possible by the advent of IPv6 which has solved the limited address space issue. With IPv6 address space, we can now assign unique addresses to all the atoms on earth and yet have enough left to do more 100 earths. The first such implementation of such a concept was done way back in early 1980s at Carnegie Melon University on a Coke vending machine. The status of the machine was available over the internet and one could enquire whether the machine was working and the drinks were available. The number of interconnected objects has now overtaken the number of humans on the planet and is expected to reach 24 billion by 2020 [9].

1.5 Applications of CPS and IoT in Water Conservation

CPS and IoT applications have already started to impact various application domains. These domains can be classified based upon the number of users, user’s involvement, network coverage and scale. The three most prominent domains are Enterprise, Utilities and; Personal and Home.

Many have already started using sensors and Wifi to make their homes more intelligent. Intelligent homes is an emerging market which presently tailor made and very expensive for most people. Simple task of automating switching on and off water heater, air conditioners can yield better energy management. Energy conservation should be the main focus of any CPS and IoT system. New research will enable more energy efficient homes which will save energy lost due to human factor. Most common example of this is climate control which is usually the most energy wasting and consuming task in any home. With a smart climate control in home, the room temperature can be adjusted according to the climate outside and can also be fine-tuned as per an individual preferences. This will prevent excessive cooling or heating and in turn save energy.

Another critical application is that of water network monitoring which has huge potential for water saving and thus having the most positive impact on the environment. Residential homes and flats have been identified as having a potential for great water savings [10].

In a case study, high efficiency fixtures were proved to save a considerable amount of water [11]. Unfortunately, however, such solutions have not been extended to the heart of the WDN. This is why sensor devices provide an essential technological infrastructure on top of which smart WDNs can be built. A smart WDN is simply defined as a system that uses CIT for monitoring its constituent parts and fine-tuning its operation to achieve the required Quality-of-Service (QoS) level at the consumer side.

1.6 Problem Statement

Significant amount of water is wasted at residential buildings and others because water is not at a suitable temperature. In winter, the water between the consumption point (sink or shower) and the water heater is cold due to lack of insulation. The common practice is to run the water down the drain until it is warm enough. In the gulf region, a similar practice is done to the hot water in summer especially if the pipes are exposed to direct sunlight. In both situations, the water is clean but is wasted because it does not have acceptable temperature. The volume of water wasted depends on the length and diameter of the pipe between the consumption point and the water heater and the frequency of water use.

1.7 Thesis Objectives

In this thesis, we aim to achieve the following objectives:

1. Design a water conservation system that will recirculate thermally rejected water by reversed flow mechanism.
2. Implement a working prototype of the designed water conservation system using microcontroller and a wireless means of communication.
3. Assess the system in terms of water saving under realistic conditions.

1.8 Contribution

There are two main contributions of this research. The first contribution is the design of an intelligent water monitoring system for a household that minimizes water wastage due to extreme or unsatisfactory temperature. The second contribution is a fully working prototype of the said design using Arduino microcontroller and XBEE communication device.

1.9 Organization of Thesis

The thesis is organized into the following chapters. After this introductory chapter, the second chapter is the literature review in which the most recent and relevant research is discussed. In the third chapter, the design of the system is presented and explained. The fourth chapter lists the hardware and their specification used in the building of the prototype. The fifth chapter describes the prototype and its working is described. In the sixth chapter we present and discuss the experimental results. Seventh chapter then concludes the research and proposes the future work. |

CHAPTER 2

LITERATURE REVIEW

In the past decade, wireless sensor networks have found a widespread acceptance and they are already being used in monitoring and information gathering applications. There is a lot of research on using WSNs for water monitoring, metering and conservation. In this section, some of the recent works in this area are reviewed. Further, their advantages and limitations are highlighted. We also take a look at the current commercial systems available in the market.

2.1 Water Monitoring System

A WSN-based system for monitoring overhead tanks was proposed in [12]. The system controls the pumping of water into the water tanks based on the level of water in the tanks. The objective was to detect the water scarcity in the tank and to control the distribution based on the available water source. The system consists of a master node that monitors the overhead tanks and remote nodes that are attached to the overhead tanks. ZigBee based network was used to transmit data from remote node to coordinator nodes. Every overhead tank has one fixed sensor node that uses a sensor to measure the level of water, a ZigBee module for wireless communication, a motor pump for pumping water into the tank and a microcontroller that controls the sensor node. Proteus Integrated Development Environment (IDE) was used to simulate the proposed prototype. A three-tank model with

three level sensors and three motors was simulated to test the proposed monitoring and distribution system. The motors were configured to switch on and off at 25% and 75% of the capacity of the tank, respectively. The results show the feasibility of the proposed system.

Another intelligent water supply management system designed only for education institutions was proposed in [13]. The system prevents water wastage by metering the water supply. It is estimated that 20 to 40 percent of the water can be saved by metering. In educational institutions, water usage is not constant rather it decreases and increases during class hours and recess time, respectively. The proposed system assigns different water flow rates to different time slots, i.e., peak and odd hours. An alarm is activated if the flow rate exceeds the preset flow rate for that particular time slot. The excessive flow rate can be due to either unattended water taps or leaks in the water pipelines. If, on inspection, it is found that all the taps are closed, then the high water rate can be due to pipeline leakage. The hardware of the device consists of a microcontroller, flow rate sensor, real time clock, matrix keypad, LCD module, status LEDs, alarm buzzer, buttons and switches. It is wall mountable and needs 5V power supply. The device has two modes of operation: settings mode and normal mode. In the settings mode, the flow rate for two time slots have to be manually entered. The device will start monitoring in normal mode. The device was tested by attaching it to a half-inch water tap. A three quarter inch ball valve is used to simulate the water leakage. In all the test conditions, the device worked as expected. However, more time slots and solar cells need to be added to the system. The main drawback of this device is that the flow rate for each time slot has to be manually programmed. The device was

tested in a controlled environment and only on a single pipe. The details of the experiments were not mentioned.

2.2 Water-Based Activity Sensing Systems

Many researchers have used different techniques to address the challenge of recognizing human activities in homes using approaches such as the installation of multiple sensors. For example, in [14], unobtrusive sensors were set up and installed in an elderly's home in order to gather several water-related activities. All the data collected by the sensors were sent and stored at a central server. The data were processed by machine learning algorithms to learn water-related behaviors. The initial setup lacked sensors for detection of water flow and monitoring electrical appliance usage. Therefore, an acoustic water flow sensor was developed for monitoring water usage activities. The noise generated when water flows through a constriction can be used to detect water activities. Frequencies below 10 kHz were excluded using a high pass filter and noise generated for less than two seconds were ignored. This helps in separating other noises, which could falsely trigger water activity detection. It should be pointed out that this method of detecting water flow is not accurate and can generate many false positives.

However, installing multiple sensors or using body-worn sensors is not a sustainable approach due to its high cost and complexity. For instance, in [15] the authors implemented a newly introduced method referred to as Infrastructure-Mediated Sensing (IMS) combined with a vector space model learning technique to recognize water-related activities in homes. IMS makes use of home infrastructure such as water lines, power lines and gas

lines, as sensors to collect information about the human actions and activities carried out on that infrastructure. The purpose of using IMS is to recognize human activities such as showers, taps and toilet flush. The system was deployed in a domestic home setting and the laundry room was selected in which two pressures sensors were installed. The data collected by the sensors was then processed and the system was able to recognize the activities related to water with an accuracy of 82.69% in case of single individual and 70.11% in case of multiple individuals.

A better water flow sensing can be achieved by sensing the vibration caused by the flow of water through the pipes. It is empirically proven in [16] that vibration in a pipe is proportional to the average water flow. A cross sectional study of a water flow rate monitoring system based on this concept was done and it was deployed in actual environments [17]. The proposed system can automatically estimate the calibration parameters and optimize them and can recalibrate itself, if necessary. A two-tiered architecture was implemented with a pre-calibrated accurate sensor on the main water pipe in the first tier and in the second tier. Uncalibrated sensors were placed on the rest of the pipes. The monitoring system consists of a base station laptop, main water flow sensor, relay nodes and wireless vibration sensors. Individual calibration parameters for each sensor is calculated and the real-time flow of water is then mapped. The system was implemented in a public restroom, a one-story building, a small apartment and in a laboratory test bed. Each implementation's duration was different but sufficient to test the proposed system validity. The experiments performed show that the system works for any type of pipes. The estimation error was less than 5% in all the cases. It was also observed that the placement of sensors on any pipe segment and the external sources of noise do not

affect the operation of the system. Vibrations from other pipes also do not affect the performance of the system. The sensors were sampled at an interval of one second, which gave a lifetime of 270 days, but the lifetime extrapolated from the collected data was 435 days. After analyzing the collected data, it was observed that 92% of the water consumed was used for sprinklers and pool related activities. In addition, hot water was used in a ratio of 1:0.23 to cold water. In the future, the authors plan to find the optimal sampling rate and implement predictive and adaptive sampling approach. They also plan to use cheaper main water pipe meter and implement this system for high rise buildings. The author's claim that "this system requires no plumbing" is not accurate. In fact, plumbing is required for the first tier sensor on the main water pipe line. This is a huge drawback as in many cases the main water pipeline is usually outside the building and not easily accessible by the customer. Another drawback of the system is that it works on the assumption that there are no water leaks. If a water leak occurs, then the system will not work as described. It will also fail to detect the water leak.

Many water-sensing systems have the problem of disaggregation, i.e., how much water usage is done by each individual fixture. By using inexpensive motion sensors, a technique referred to as WaterSense performs fixture level disaggregation [18]. The system consists of a water flow meter that is installed on the main water line and a motion sensor in each room, which has a water fixture. The algorithm used for sensing has three tiers where in the first tier, edge detection is performed on water flow data to find the sequence of water flow events. In the second tier, the water flow events are grouped according to the motion sensor. Finally, in the last tier, each fixture's flow event is separated from the data according to the flow signatures. The WaterSense system was deployed in two homes for

a period of seven days and was able to achieve 86% classification accuracy in disaggregating water flows and estimating the individual fixture's water flow with an accuracy of 81.5% and 89.9% for first and second homes, respectively. The main drawback of this system is that it is unable to distinguish water flow from identical fixtures in the same room.

Another important concern when using sensors is energy consumption. As the energy consumption of the sensor increases, the lifetime of the network decreases. This problem was addressed by WATTR [19] and DoubleDip [20]. WATTR is a self-powered sensor that is designed to monitor and transmit water usage data without using battery power. The sensor is powered by the same water pressure signals that it measures. In addition, it does not waste water to power itself, as it is not an inline flow meter. A rotational power harvester is used to generate electricity by converting water pressure to rotational motion. The energy and the sampling capacity of the sensor was analyzed using data from three sources, i.e. sink, bathtub and laundry machine over a period of 10 trials. WATTR was able to classify with an accuracy of 93% and hence making it a viable replacement for sensors used in the Hydrosense system [21]. However, the test data and the test time were very limited and the applicability of the system for general use is not analyzed.

DoubleDip is another water flow monitoring system that harvests energy, consumes low power and is non-intrusive. In this case, a thermoelectric generator is used to gather energy by using the thermal gradients in the hot and cold pipes. The authors observed that water use is sporadic and hence continuous water monitoring is a waste of energy. DoubleDip stays in a deep sleep state when there is no water flow to conserve energy. It uses the vibrations caused by a water flow in the pipe to wake up and start monitoring. The system

was evaluated over a period of four weeks across five locations, i.e., 3 residences and 2 university restrooms. The system was able to detect water flow with high accuracy and with no false positives. However, in some occasions, it missed some water flow events and had a latency of 4 seconds.

2.3 Water/Energy Conservation Systems

Circulo [22] is a system which is similar to our system. Circulo learns the usage patterns of hot water in a home and then the hot water is circulated as per specified program. Whenever the taps are used, the water is initially cold and has to be flushed until the hot water arrives from the heater. This delay in hot water leads to user frustration and wastage of water due to flushing. The existing solution to these problems is to use a Hot Water Recirculation (HWR) pump, which makes the hot water available instantaneously by recirculating the hot water continuously. The drawback of using HWR is wastage of electrical energy in continuously pumping water. There is a continuous heat loss from the un-insulated hot pipes; which the electrical water heater must compensate. Circulo takes advantage of the fact that hot water in many homes is used at certain times. A Naïve Bayes model is used to model the hot water usage. The prediction models are built to detect chronographic patterns of hot water usage without knowing the absolute time or day. Circulo's setup consists of a microcontroller to operate the pump and a Zigbee sensor to detect hot water usage. It was setup in five different homes for about 7 to 10 days and the data about water and energy usage was collected. The results show that the total energy usage was reduced to 12 KWh/day from 18 KWh/day. It was observed that 90% of the time

the hot water was available for use. However, the wait time per user and effects of mis-predictions on hot water usage time is left for future research.

2.4 On-Demand Hot Water Recirculation

Circulo was an example of Enhanced Timer Controlled HWR. The disadvantage of such a system is that user does not get hot water during the ‘off’ period of the pump. During the ‘on’ period of the pump, if the user does not need the hot water then water is unnecessarily recirculated. Such a system still wastes water and energy but less compared to always on HWR. A better solution is to use an on-demand HWR. In such a system, hot water is circulated only when the user demands it. The pump is installed at the furthest user end point. The cold water present in the line is returned to the water heater either through the dedicated return line or the cold water line by the pump. A thermal sensor is used in order to shut off the system when hot water reaches the user. The system can be activated either using a hardwired push button, motion sensor or a remote push button. ReadyTemp [23], Taco [24], Enovative[25] and Chillpepper [26] are examples of commercial on-demand HWR. These commercial systems are only available in the United States. The disadvantage of these systems is that the pump is installed at the user’s end point. This creates unnecessary noise pollution and can cause irritation to the user. Another disadvantage is that the water is circulated against the flow of the water from the main water supply. This causes the pump to use more energy to recirculated water. This illustrated and explained in the next chapter.

CHAPTER 3

SYSTEM DESIGN

Significant amount of water is wasted at residential buildings and others because of water is not at a suitable temperature. In winter, the water between the consumption point (sink or shower) and the water heater is cold due to lack of insulation. The common practice is to run the water down the drain until it is warm enough. In the gulf region, a similar practice is done to the hot water in summer especially if the pipes are exposed to direct sunlight. In both situations, the water is clean but is wasted because it does not have acceptable temperature. The volume of water wasted depends on the length and diameter of the pipe between the consumption point and the water heater and the frequency of water use.

The solutions to this problem are either costly or ineffective. One solution is to use a Hot Water Recirculation (HWR) which is also expensive not in terms of energy but sometimes in in terms of water as well.

We propose a thermal rejection system [27] that addresses both hot water and cold-water needs in buildings in the gulf region. It can be retrofitted to most buildings. The system design and operation is explained in further details below.

3.1 Thermal Rejection System Design

In this section, we first present the existing design of the WDN found in homes and then present our system design which makes minimal modification to the existing system. Existing homes have their water supplied from a water source such as the mains supply or a central water tank (placed either on top of the building or underground). A pump may be installed after the water source to provide adequate pressure as per the consumer requirement. The water supply is split into two lines, one for cold (normal) water and other for the hot water (energized) as seen in Figure 3-1. The supply cold line feeds the water heater then both the cold water line and the hot line run directly to the end user points such as wash basins, shower, washing machines, dish washers, taps etc.

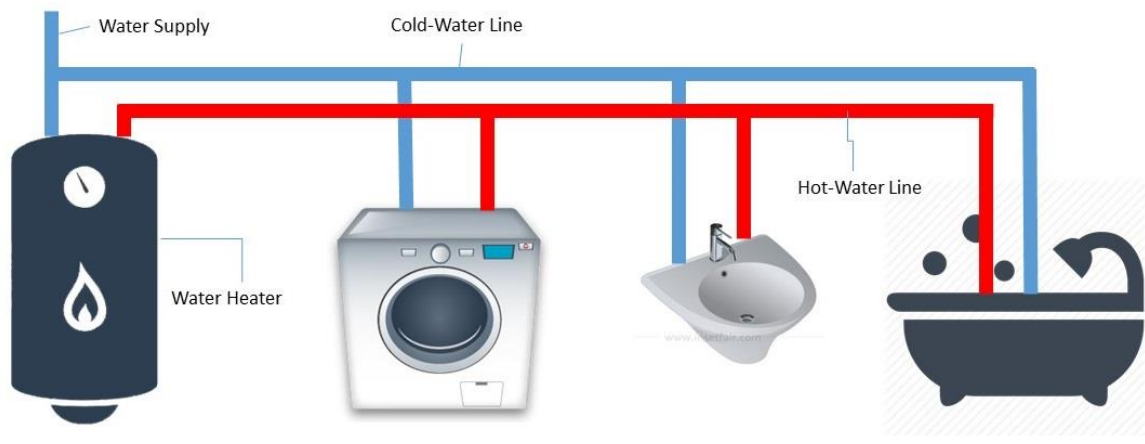

Figure 3-1: Traditional WDN

However, some domestic WDN are installed with a return line to the water heater with a recirculation pump as shown in Figure 3-2. The hot water is continuously circulated. This reject-line forms a loop in the water supply back to the heater and a pump must be installed

on the loop. The pump is operated all the time ensuring that the hot water is always available to the user at any given time. The disadvantage of such a system is that a lot of energy is consumed by the pump for always recirculating the water and by the water heater compensating for the heat loss from the uninsulated pipes.

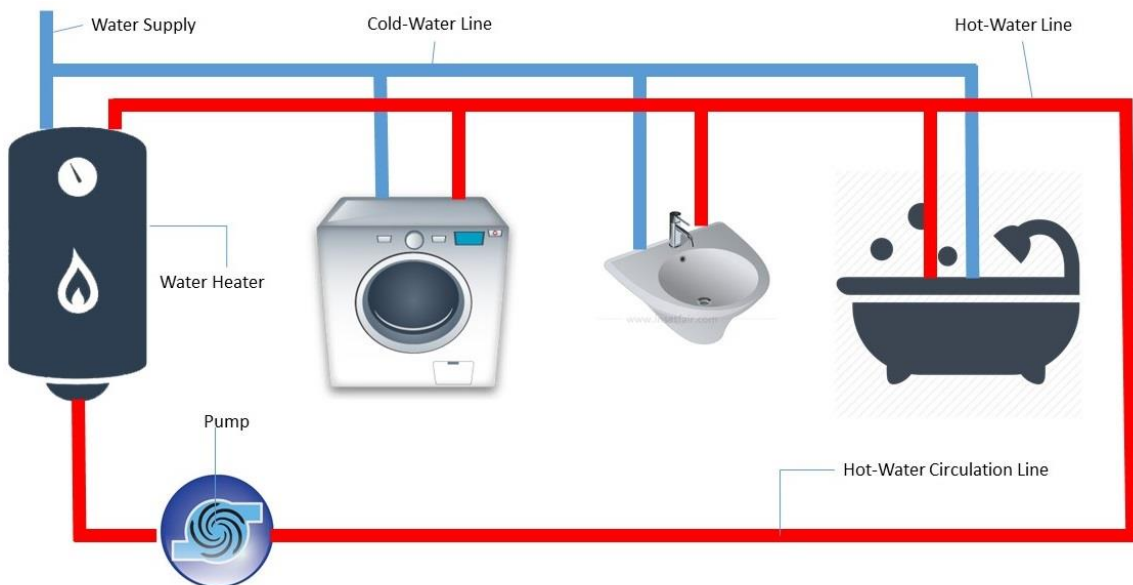

Figure 3-2: HWR with pump

On-demand HWR has the pump installed at the farthest user fixture from the water heater as seen in Figure 3-3. The pump is attached to the hot and cold lines using a tee. Whenever the user's requires hot water, the pump is started. The pump pushes the cold water in the hot line back to the water heater through the cold line. However, since the main's supply is still open, the pump has to push against the flow from the mains. Because of this, the pump expends more energy than needed to recirculate.

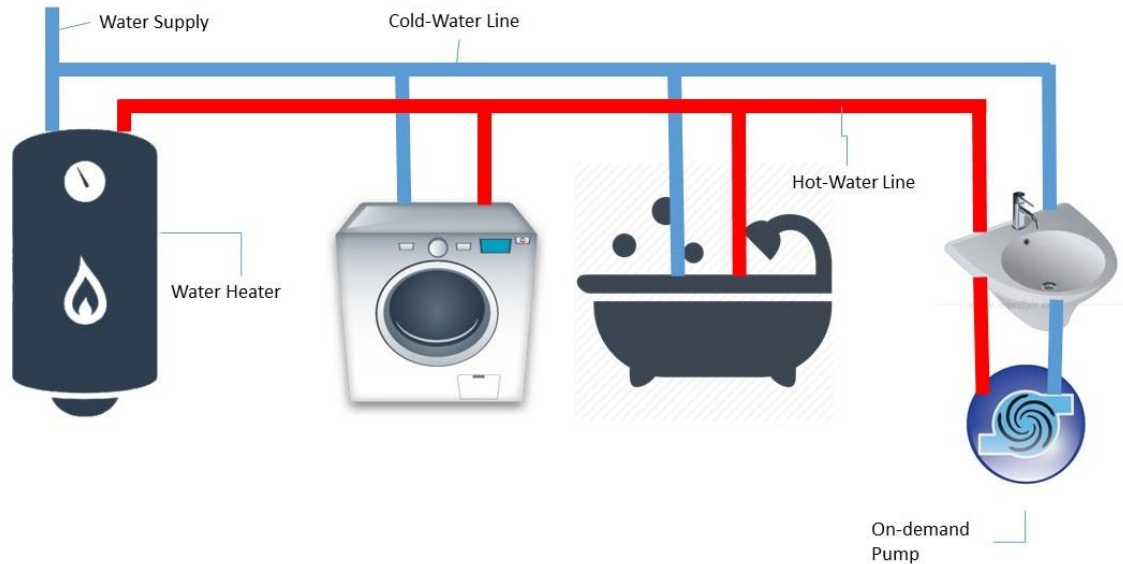

Figure 3-3: On-demand HWR

We propose two unique design for the domestic WDN i.e. for tank and tank-less systems. These designs make minimal changes to the existing WDN and ensure that no water is wasted because of its unsatisfactory temperature.

3.1.1 Tank-less System

The most common WDN in homes is to have the water supplied directly from the mains water supply. In our conservation system, we propose to add two control boxes as seen in Figure 3-4. One box is installed near the user’s end and the other is near the water heater called the front and back boxes respectively. The “front box” adds a bridge connecting the hot and cold line via a controllable valve. The “back box” is installed right near the inlet and outlet of the water heater. The back box also bridges the hot and cold line via a controllable valve and a pump. Another controllable valve is installed right after the mains supply point and a one-way check valve on the supply line feeding to the water heater.

Both the boxes are equipped with a temperature sensor and wireless means of communication.

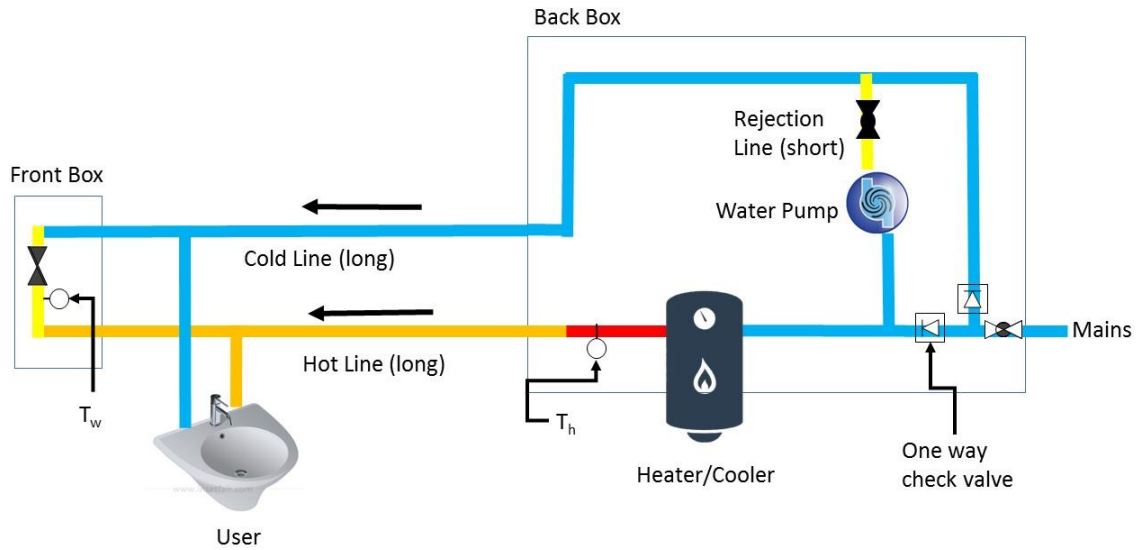

Figure 3-4: Tank-less System - Normal Operation

The water that is normally wasted due to it being of uncomfortable temperature (also called thermally rejected water) is conserved using the thermal rejection process as seen in Figure 3-5. The user initiates the thermal rejection process where both front box and the back box perform the process together. The back box closes the valve on the main line isolating the network after it. The valves in the front and back box are opened creating a loop between the hot and cold water lines. The pump then becomes a part of the loop and starts to recirculate water from the hot line (too cold-water) back into the water heater through the cold line. The temperatures of the water flowing out of the water heater and at the front box are continuously measured. This process is continued until all the hot water reaches the front box. The old cold water has been returned over the cold line to the water heater.

This is how the thermal rejection process saves water of unsatisfactory temperature. The same process can also be used to reject hot water during summer as well. The cold water will be either the heater acting like a cold-water tank.

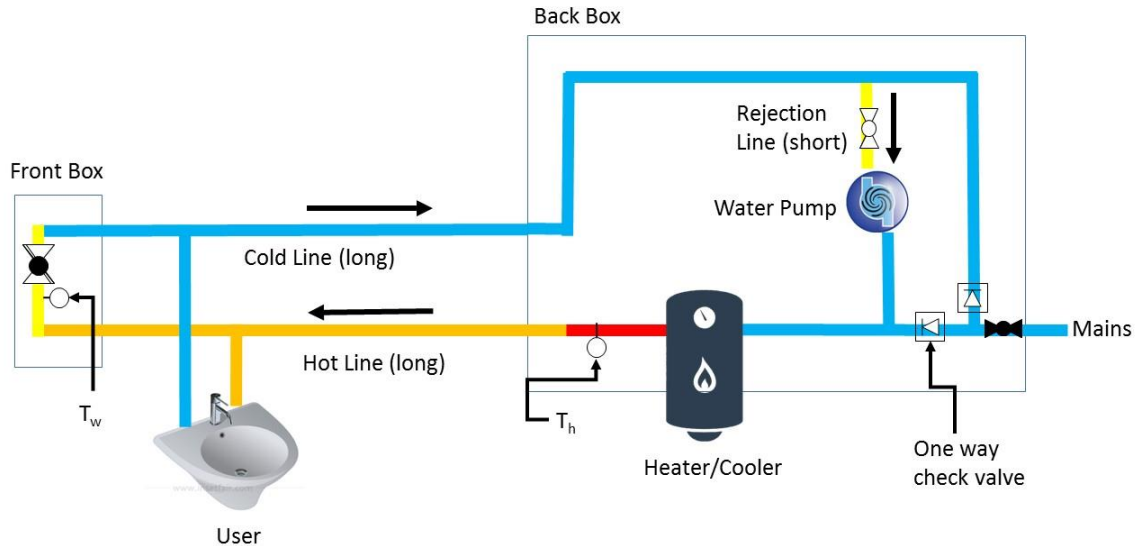

Figure 3-5: Tank-less System – Thermal Rejection Operation

3.1.2 Tank-based System

For domestic WDN, which has a main tank (Figure 3-6), we propose a thermal rejection system that uses a short reject line. The reject line runs from near the water heater to the water tank as seen in Figure 3-6. The reject line connects both the hot and cold line to the water tank. It connects to the hot line right after the outlet of the water heater. In this system design, the front box bridges the hot and cold lines via a controllable valve. However, the back box bridges the hot and cold lines to the return line via two controllable valves for each line. In addition, the two control boxes are fitted with temperature sensors. The unfit water is thermally rejected from both the lines and that water by the back box and is

returned back to the water tank. There are two modes of thermal rejection i.e. summer mode and winter mode which are described next.

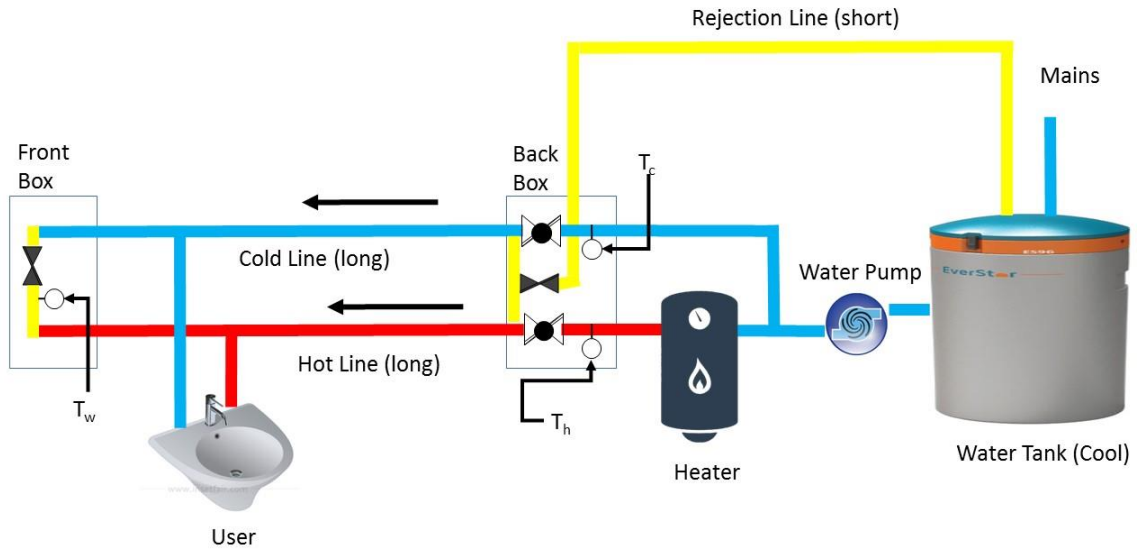

Figure 3-6: Tank System: Normal Operation

3.1.3 Winter Operation

In the winter, the water left in the water pipe after usage is cooled due to the pipe exposure to the natural coldness. The water then becomes too cold for use especially for showering. This water then becomes uncomfortable and is wasted drain until the hot water arrives from the water heater. The user initiates the rejection process by using a button connected to the front box. The front box first opens the valve connecting the hot line to the cold line. The back box closes the valve that connects the hot line to the reject line but opens the valve that connects the cold line to the reject line. The pump is then switched on which pushes the cold water in the hot line toward the tank via the cold line. This process is continued until all the cold water in the hot line is removed and the hot water from the water heater

reaches the front box. This is how the winter operation of the thermal rejection for the tank system avoids water wastage.

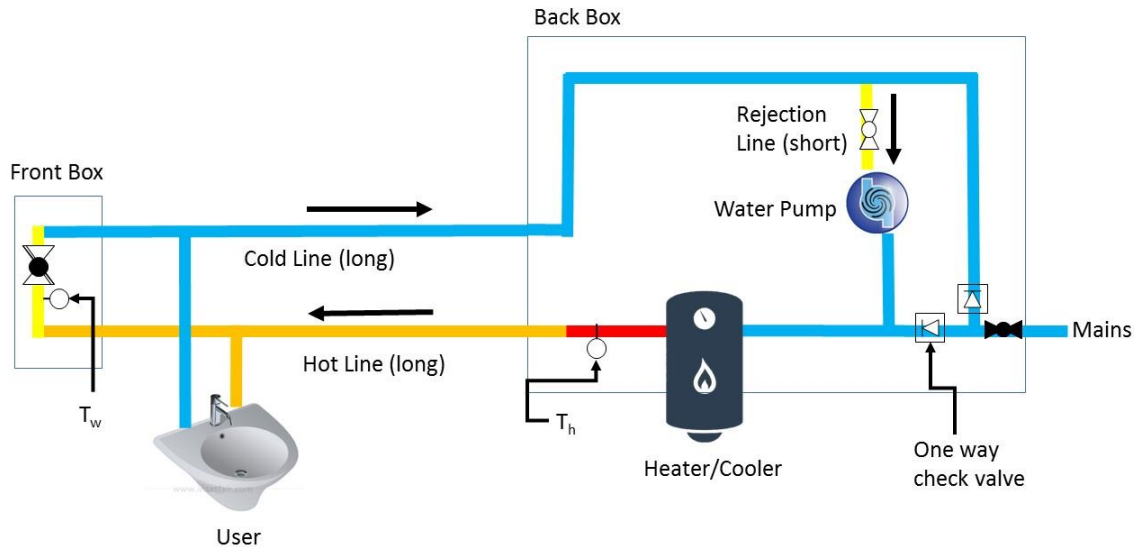

Figure 3-7: Tank System - Winter Operation

3.1.4 Summer Operation

In the summer, the water left in the water pipe after usage is heated up due to the pipes being exposed to extreme heat. The water in the cold line then becomes too hot for usage and is normally flushed down the drain until cold water from the tank arrives. In the summer operation mode, the user or a button on front box first initiates the thermal rejection process. The front box opens the valve thereby connecting the cold line to the hot line at the user's end. The back box closes the valve that connects the cold line to reject line and opens the valve that connects the hot line to the reject line. The back box then switches on the water pump, which pushes the cool water from the tank to clear the water, which is too

hot in the cold line. That water passes through the bridge of the front box into the hot line. The water then flows through the hot line until it reaches the back box and it is then diverted in to the reject line and ends ultimately in the water tank. This process is continued until acceptably cool water reaches the front box thermometer. This is how the summer mode of the thermal rejection for the tank system prevents water wastage.

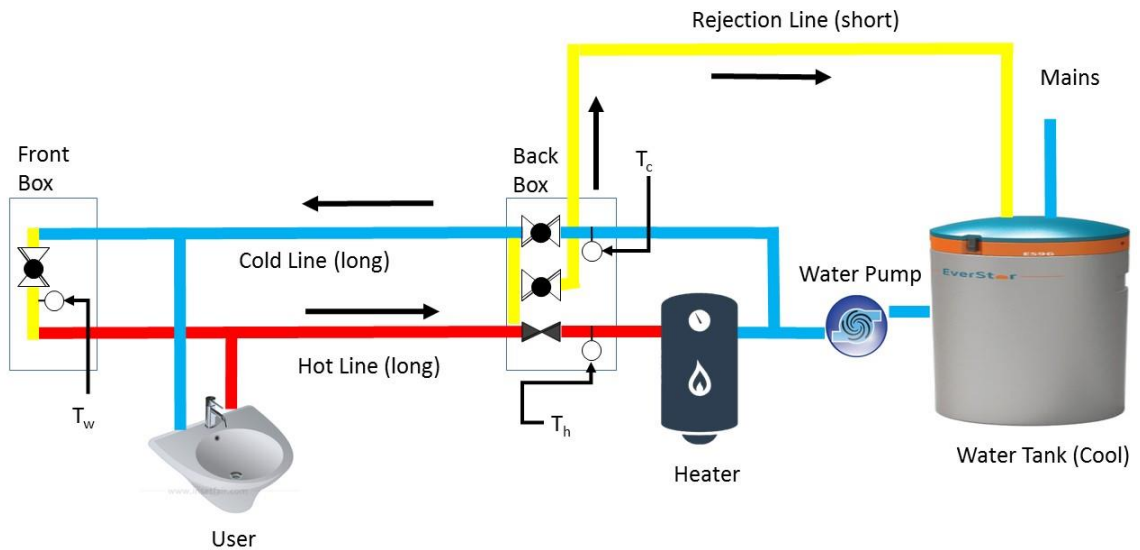

Figure 3-8: Tank Operation - Summer Mode

CHAPTER 4

HARDWARE

In this chapter we present the hardware components and modules used in the research and building of the prototypes. The list of hardware is as follows: Arduino microcontroller, Relay Board, XBEE Pro, XBEE Explorer, XBEE Shield, Flow Meter, Solenoid Valves and Temperature Sensor.

4.1 Arduino

Arduino is an electronics prototyping platform that is open source, simple to learn and use. Arduino is a tool, which allows the computers to sense and control the physical world. It is also the name of the company that designs and manufactures the microcontroller board and kits, which can be used to create interactive environments. Compared to the existing microcontroller platforms in the market; Arduino is inexpensive, operating system independent, open source, extensible, simple and easy to program. Appendix B contains the code used to program the Arduino microcontrollers in the front and back box.



Figure 4-1: Registered Logo of Arduino

The platform consists of both software and hardware. The hardware consists of a simple microcontroller board and the software is an integrated development environment that can be used to program the microcontroller. A typical Arduino board contains an ATMEL microcontroller and other components that enable programming and addition of more circuits. The microcontroller is based on Atmel's ATMEGA168 and ATMEGA8 microcontrollers. It is preprogrammed with a boot loader that makes it easy to upload program directly onto the on-chip flash memory. The board comes equipped with standard connectors, which allows the user to add-on interchangeable modules called "Shields". These Shields extend the functionality of the board such as wireless connectivity, GPS, LCD or motor control.

The Arduino software consists of an integrated development environment (IDE) and core libraries. The IDE is derived from the Processing language development environment and is written in JAVA. But the core libraries are written in C/C++ language

4.2 Arduino MEGA 2560

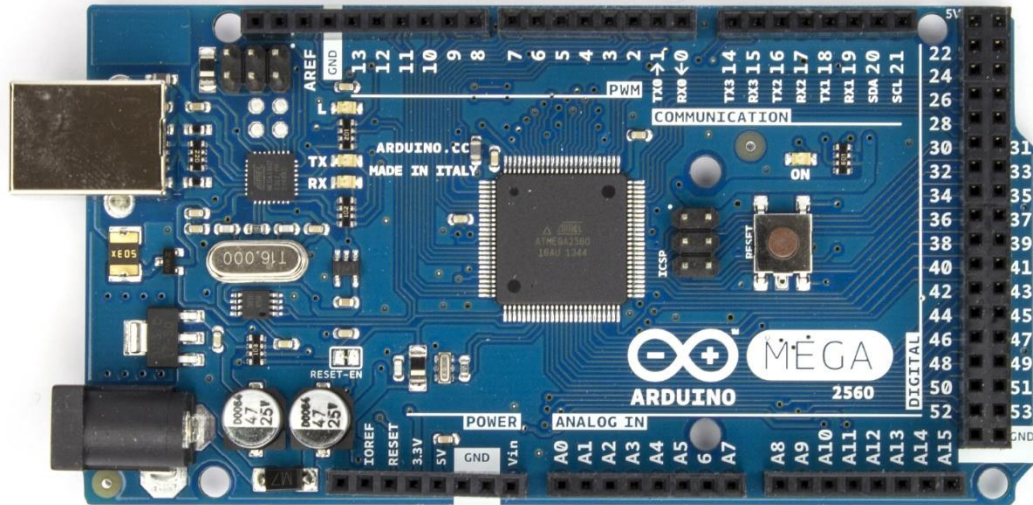

Figure 4-2: Arduino Mega 2560 R3 Front

Arduino MEGA 2560 microcontroller board shown in Figure 4-2 is based on the ATmega2560. The feature of this microcontroller is that it has 16 analog input pins, 54 digital input/output pins, 4 UARTs [define], a power jack, a reset button and a USB connection. This is the 3rd revision to the original Arduino Mega. A USB cable connected to a computer is simply need to power it up and use it. It can also be powered by an external power supply of 7 to 12 volts. The digital pins can used either as input or output and can receive or provide a maximum current of 40mA. The analog pins can measure from ground to 5 volts and provide at most 1024 different values (10 bit resolution). Table 4-1 gives a brief summary about its specifications.

Microcontroller	ATmega2560
Maximum Input Voltage	20V
Recommended Input Voltage	7-12V
Operating Voltage	5V
I/O Pins (Digital)	54
Digital I/O Pin DC Current	40 mA
Analog Input Pins	16
Clock Speed	16 MHz
Memory (Flash)	256 KB
SRAM	8 KB
EEPROM	4 KB

Table 4-1: Specification of Arduino Mega 2560

4.3 ZigBee

ZigBee is an open global wireless standard used as the foundation for many local WSN. Wikipedia [28] defines it as “a specification for a suite of high-level communication protocols”. It is based on Institute of Electrical and Electronics Engineers (IEEE) 802.15.4 standard and uses its physical radio specification. ZigBee operates on the unlicensed radio frequency bands such as 868 MHz, 900 MHz and 2.4 GHz. It was created in 1998 but was standardized in 2003 and last updated in 2006. This protocol is maintained and updated by the ZigBee Alliance. This alliance is an organization of various companies that works to keep an open global standard.

The protocol was created to enable high data throughput in networks with devices that have limited power and low power consumption is a prerequisite for the network. It is a packet based radio protocol developed for inexpensive battery powered devices. It supports a variety of network topologies and can extend a network lifetime to several years. It can even transfer data through hostile radio frequency environment commonly found in the industrial physical plant and automation. The advantages of using ZigBee protocol include:

- Provides long battery life by using low duty cycle
- Supports secure data connections by using 128-bit AES encryption
- Collision avoidance, retries and acknowledgements
- Supports up to 65,000 nodes in a network
- Supports various network topologies such as point-to-point, star, cluster tree and mesh networks



Figure 4-3: Various Application of ZigBee

Normally ZigBee is used to create a Personal Area Network (PAN) and each PAN can have only one coordinator device. ZigBee protocol defines three types of devices: Coordinator, Router and End Device.

Coordinator is the most capable device in the ZigBee network. It is the root of the network and acts a bridge between other PANs. There can only be one Coordinator per network as it is the device the initially created the network. Because of this it has to be continuously on and never be put to sleep. A radio channel and a unique PAN is selected by the coordinator when starting the network. It is then responsible for allowing end devices and routers to join the network and assist routing of data.

Router is the next most capable device in the network after the coordinator. It, as the name suggests, acts as an intermediate router transferring data between devices. Also like the coordinator device, it can never go to sleep.

End Device should be capable enough to communicate with a parent node i.e. a Coordinator or a Router. It must be a part of the PAN in order to receive and send data but is unable to add other devices to the network. It cannot transfer data from other devices and must use parent node to communicate with other devices. Because of this functionality, End Device can be put to sleep thereby increasing its and the networks lifetime.

The main feature of ZigBee is its capability to create mesh networks in which multiple nodes are connected to each other with multiple paths connecting each node. The node's interconnections are dynamic in nature. They are optimized and updated through a sophisticated mesh routing table. These networks are decentralized and each device is able to self-discovery in the network. As the nodes leave and join the network, the network topology changes and routing paths are reconfigured based on the new topology. These characteristics of self-discovery and ad hoc routing give the mesh network great tolerance for failure of single nodes. ZigBee protocol also supports star and cluster tree network

topology. A star topology contains a coordinator node at the center of the network and all data is passed through the coordinator node. A cluster tree topology is formed when multiple star topology are connected to each other. The various topologies is shown in the Figure 4-4.



Figure 4-4: Various ZigBee Topologies

4.4 XBEE-PRO



Figure 4-5: XBEE-PRO RF Module

XBEE is the name for the family of compact small form Radio Frequency (RF) modules manufactured by Digi International. These modules are used to receive and transmit radio

signal on various frequencies and can also be used to setup ZigBee mesh networks. They can be used for a wide variety of monitoring and controlling applications such as home automation systems, smart grid, tank monitoring and lighting controls. Little or no programming/configuration is required. They come in two form factors i.e. Surface Mount and Through Hole with 20 pin socket.

XBEE-PRO modules are different from the regular XBEE modules. They have a high range of transmission (2 miles compared to 400ft) but consume more power. The specifications of the XBEE-PRO module are given in Table 4-2.

RF line of-sight range (Outdoor)	Up to 2 miles (3200 m)
Indoor/urban range	Up to 300 ft. (90 m)
Dimensions	2.438 cm x 3.294 cm
Operating frequency band	2.4 GHz
Number of channels	15 Direct sequence channels
Transmit power output	63mW (+18 dBm)
Data throughput	up to 35000 b/s
RF data rate	250,000 b/s

Table 4-2: XBEE-PRO Module Specification

4.5 XBEE Shield

The XBEE shield extends the capability of an Arduino board to use XBEE RF modules. This allows it to communicate wirelessly using ZigBee protocol. Its form factor enables it to fit directly on top of the Arduino and works with all popular varieties of XBEE RF modules.

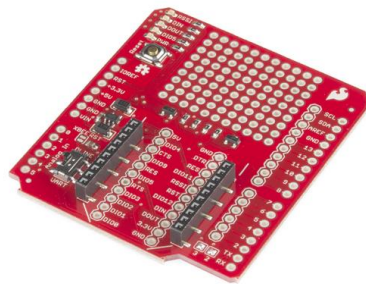

Figure 4-6: XBEE Shield without pin headers

The shield comes equipped with an UART/SoftwareSerial Switch which determines how the XBEE's serial communication connects with the USB-to-serial chip on the Arduino or the serial communication of the microcontroller on the Arduino Board. This is necessary as the Arduino has a single UART either used for communication with the serial monitor or for programming at any given time. This leads to bus contention on the serial port. By using the UART switch and Software Serial library, we can switch connection of the XBEE serial pins (DOUT and DIN) between software serial port pins and the hardware serial port.

The shield provides the XBEE with regulated 3.3V DC from the 5V pin of Arduino. The level shifting of the DOUT and DIN pins of the XBEE is also performed using a MOSFET level shifter. There are five LEDs on the shield, which are very useful for debugging. The LEDs indicate power and activity on the DOUT, DIN, DIO5 and RSSI pins of the XBEE.

Table 4-3 explains each of the LEDs function.

LED Label	LED Color	XBee Pin Connection	Default Operation Notes
PWR	Red	3.3V	Indicates power is present.
DOUT	Red	DOUT	Indicates wireless data is being received.
DIN	Green	DIN	Indicates wireless data is being transmitted.
RSSI	Green	PWM0/RSSI	Indicates relative signal strength (RSSI) of last received transmission.
DIO5	Green	Associate/DIO5	Associated indicator -- blinks when the XBee is associated with another XBee.

Table 4-3: XBEE Shield's LED Functions

4.6 XBEE Explorer

XBEE explorer is an easy to use base unit that converts USB connection to serial so that it can be used with the XBEE RF modules. A mini USB cable is needed to program XBEE using the explorer. The main component of this board is the FT231X USB-to-Serial converter. Similar to the XBEE shield it also comes with a voltage regulator and four LEDs for TX, RX, RSSI and power. The explorer without and with a XBEE RF module is shown in the Figures 4-7 and 4-8 respectively.

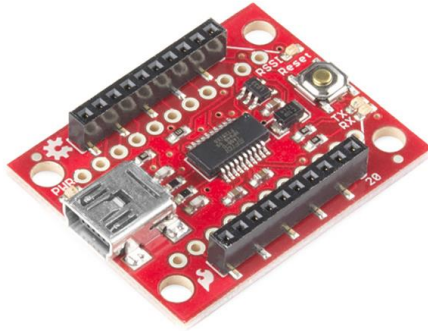

Figure 4-7: XBEE Explorer

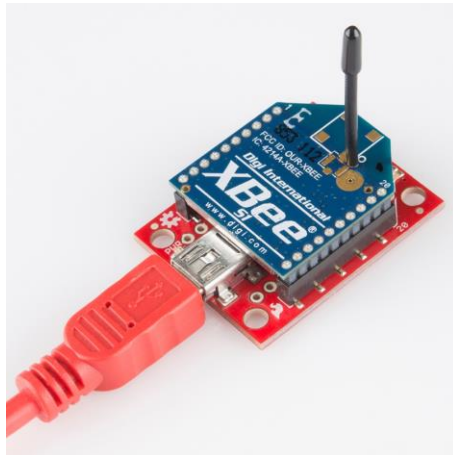

Figure 4-8: XBEE Explorer with XBEE RF Module

4.7 Flow Meter



Figure 4-9: Pinwheel Flow Meter

Flow meter is a device used to measure the flow rate of a liquid or gas in a pipe. There are three types of flow meters i.e. mechanical, pressure-based and optical. We will be using a pinwheel mechanical type of meter. The number of spins the pinwheel makes is measured by a Hall Effect magnetic sensor attached on the other side of the plastic tube. As seen in Figure 4-9, the flow meter comes with three wires: yellow for the Hall Effect pulse output, red for the 5-18V DC power supply and black for the ground. The flow of the fluid can be tracked by counting the pulses from the output. Each pulse is about 2.25 millimeters but has a 10% precision. It can measure flow rate from 1 to 30 liters/minute

4.8 Solenoid Valve

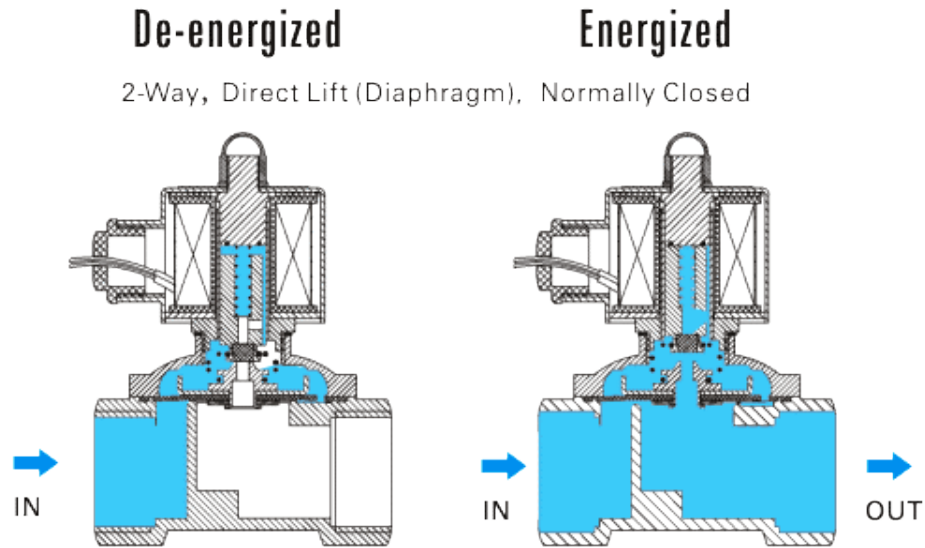

Figure 4-10: Operation of a Normally Closed Solenoid Valve

A solenoid valve is a valve that is operated electromechanically. As the name suggest, it has two main parts i.e. the valve and the solenoid. As shown in Figure 4-10. , the electrical energy supplied to the solenoid is converted to mechanical energy which then mechanically opens the valve in normally closed valve. The normally open solenoid valves, energy is used to close them. A spring is used to hold the valve closed or open when it not activated depending on the type of the valve i.e. normally closed or normally open respectively. The valve's body can be made up of various materials such as plastic, stainless steel or brass.



Figure 4-11: Brass Solenoid Valve



Figure 4-12: Plastic Solenoid Valve

We have used both plastic and brass solenoid valves shown in Figures 4-11 and 4-12 respectively. But the plastic solenoid valve requires a minimum pressure of 3 PSI (0.02 Mpa) to activate. Whereas the brass solenoid valve does not require any minimum pressure as it does not have a gasket unlike the plastic solenoid valve. The specification for both the valves is given in the Table 4-4.

Technical Specification	Plastic Solenoid Valve	Brass Solenoid Valve
Normal/de-energized State	Open	Closed
Working Pressure	0.02 Mpa to 0.8 Mpa	0 Mpa
Actuating voltage	12VDC	12VDC
Working Temperature	1 °C - 75 °C	-5°C - 80 °C
Dimensions	3" x 2.25" x 2"	105mm x 55mm x 65mm
Weight	4.3 oz	1.7lbs

Table 4-4: Specifications of the Solenoid Valves

4.9 Relay Board

The solenoid valves are operated using electrically operated switch called Relay. They are used in many applications that require control switching. They are known for their reliability, long life and simplicity. An electromagnet is used in the relay to mechanically operate the switch. Whenever the applied voltage or current reaches a certain value, the switch activated either to close or open the contacts.

The 4-channel relay board manufactured by Sainsmart shown in Figure 4-13 is used in the prototype. A 15-20mA driver current and 5V is needed to operate the relay. The relay can handle voltages up to 250V AC and 30V DC at 10A. The board has opto-isolated inputs by which it can be safely controlled by a microcontroller.



Figure 4-13: 4-Channel Relay Board

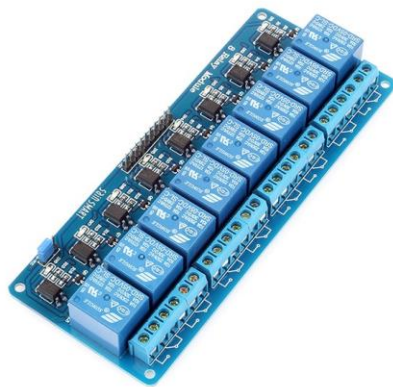

Figure 4-14: 8-Channel Relay Board

4.10 Temperature Sensor

A waterproof and pre-wired version of the DS18B20 shown in Figure 4-14 is used as the temperature sensor. DS18B20 is a digital thermometer providing 12-bit to 9-bit temperature measurements in Celsius. It uses 1-Wire bus for communication, which means that a single data line is needed. It does not require a separate power supply as it obtains power directly from the data line. It can operate in a temperature range from 125° C to -

55° C with an accuracy of 0.5° C. It is advised to use it under 100° C due to the presence of the PVC jacket. Each sensor has a unique 64-bit ID and because of which multiple sensors can be used on a single digital pin. The cable is 91 cm long and the stainless tube is 30mm long with diameters 30mm and 4mm respectively.



Figure 4-15: Waterproof Temperature Sensor

CHAPTER 5

PROTOTYPE AND EXPERIMENTAL RESULTS

5.1 Tank-less Physical Setup

The physical prototype is built based on the design (Figure. 5-1) using the above-mentioned hardware. A 64 liters (17 gallon) container is used as the water source and it represents a tank. A pump is used to provide pressure in the system. A solenoid valve is fixed right after the pump. This valve is controlled by the back box and is used to shut off the water source during the thermal rejection process. The line is then split into hot and cold water supply lines. Both the lines are fitted with a one-way valve that prevents any back flow. A bridging pipe connects the cold and hot lines through two tees near the heater (back box). Another bridge is installed near the user outlet (front box). The hot line goes to the inlet of the heater but not before the back bridge. In this way, the back box bridges the hot and cold line near the water heater and source. The back box controls a solenoid valve and a pump, which takes parts in the thermal rejection process. A flow meter is present to calculate the amount of water the pump recirculates in the rejection process. This flow meter is not needed for operation but we used it to characterize water savings.

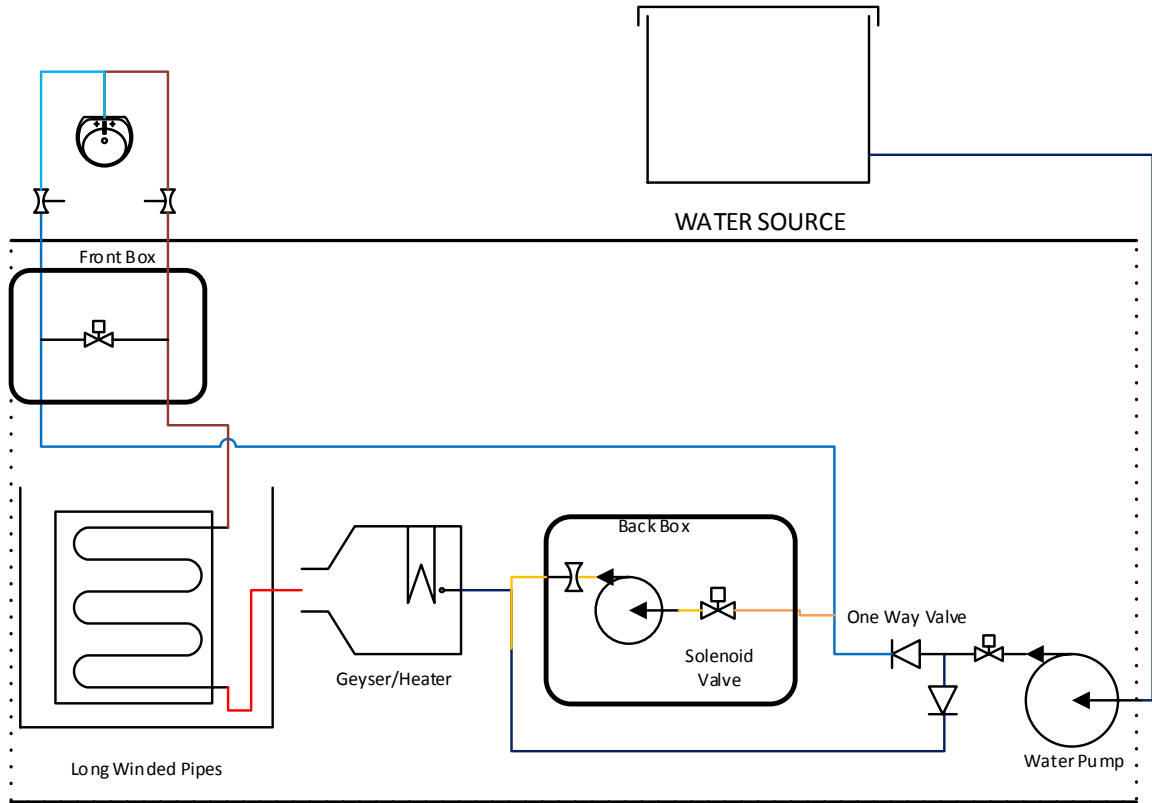

Figure 5-1: Layout Design of the Prototype

The outlet of the water heater is connected to a 25m winded hose placed inside a cold container. The container is filled with ice and cold water in order to simulate the cooling of the hot pipes during winter. The hot line continues to the user outlet. It forks just before the user to the front box, which contains two tees, are used to bridge the hot and cold lines just before the user outlet. A solenoid valve is fixed on the bridge, which is controlled by the front box during the thermal rejection process. The hot and cold pipes then continue on to the user end, which in our case is a tap. A mixer type tap is used in which the user can swivel the handle to get the proper mix of hot and cold water.

Appendix A contains images of the physical system. The pipes were tape-colored to illustrate functions: blue for cold, red for hot and yellow for rejection.

5.2 Tank-based Physical Setup

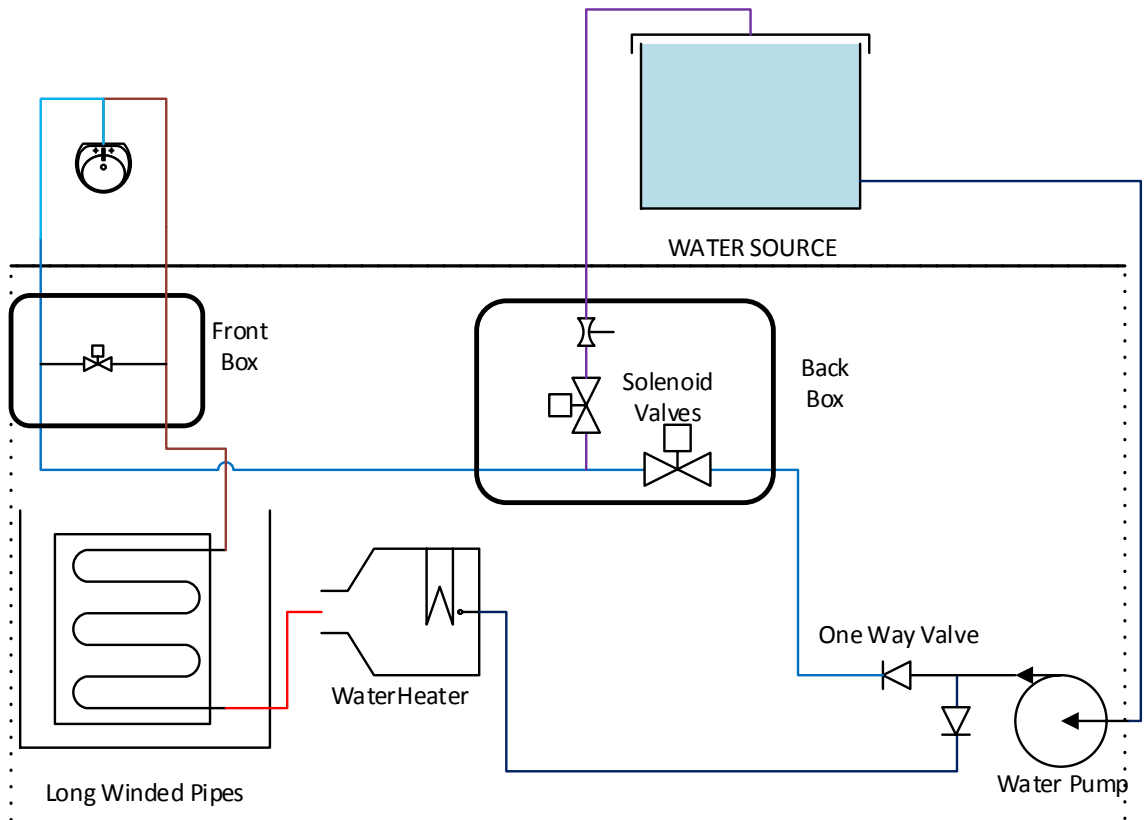

Figure 5-2. Layout of Tank-based Prototype

We also built a prototype based on the Tank-based thermal rejection design. The previously built tank-less prototype was modified as shown in Figure 5-2. A tee is installed on the cold line and a short rejection line is then connected to that tee. This rejection line then connects the cold line back to the tank. A solenoid valve is installed on the rejection line and on the cold line just before the tee. A flow meter is also installed on the cold line in order to calculate the amount of water returned back to the tank. These valves and the mains water pump are controlled by the back box. The winter mode operation is

implemented by closing the valve on the cold line and opening the valve on the rejection line.

5.3 Tank-less Experimental Results

To evaluate the effectiveness of the thermal rejection process, various data was logged during the process. The data was collected from the temperature and flow sensors attached to the prototype during the rejection process. Figure 5-3 displays the variation of the temperature as recorded by the sensors at the heater's outlet and at the user's end. The x-axis displays the time in seconds and milliseconds and the y-axis displays the temperature in degree Celsius. Initially the temperature is 38.5 °C and 23.37 °C at the heater's outlet and user's end respectively. It takes a few seconds for the hot water to start flowing from the heater as the pumping starts. This can be seen after 10 seconds when the temperature at the heater's end rises to 42 °C. The temperature at the user's end remains fairly the same for 15 seconds then starts to rise. This is because all the cold water in the hot-water line is being flushed out during the rejection process. It can be seen in the graph that the user's end temperature then increases steadily as the hot water starts to arrive. The rejection process is programmed to terminate when the user's end temperature is five degrees less than that of the heater's outlet. This value at which the process terminates can be set as per the user's requirement. At the end of the rejection process, the temperatures are 41.38 °C and 38.56 °C at the heater's outlet and user's end respectively. The complete rejection process takes about 30 seconds. This graph does reflect the realistic operation of the thermal system. The temperature at the user's end should have a sharp increase compared

to the gradual increase seen in the prototype. This is due to the prototype design not the system design. The long winded pipe the carries hot water to the user is only cold inside the bucket. There are parts of the hot water line which are not cold and this causes the described behavior of the temperature variation. The drawback of this behavior is that after the thermal rejection process is completed, there will be warm water present in the cold line. It is expected that such behavior will not occur in a real time deployment of the thermal rejection system.

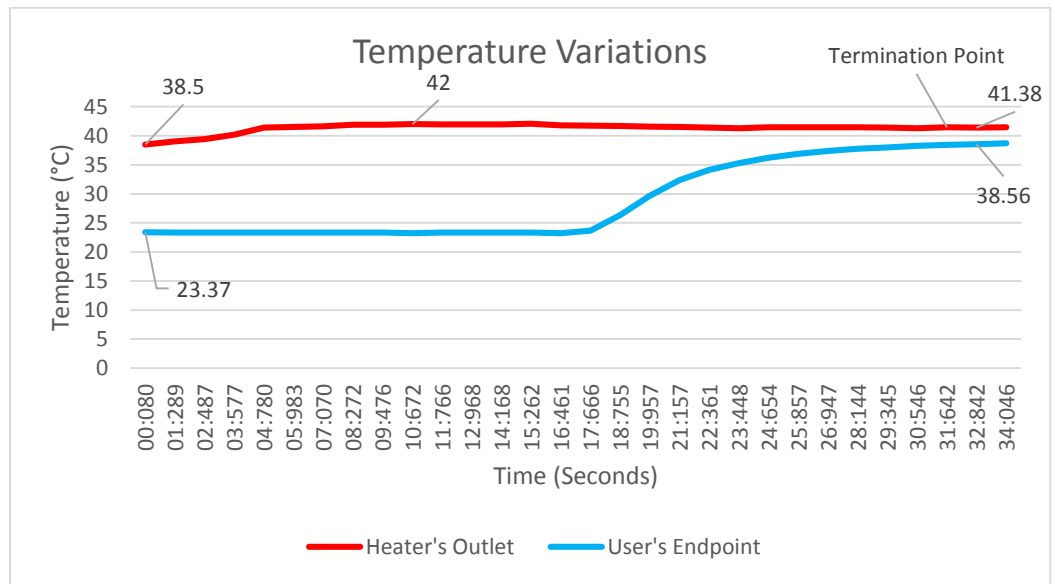

Figure 5-3: Temperature Variation at the heater and user's end during the thermal rejection process

The details of the flow rate and amount of water saved were also logged from the water flow sensor. Figure 5-4 shows the graph of the flow rate during the thermal rejection process. The x-axis shows the time in seconds, milliseconds, and y-axis the flow rate at any given time in liters per minute. The flow rate starts from 0.9 l/min and then mostly remains constant at 11 liters/min with minor fluctuations. Figure 5-5 shows the total amount of water saved during the rejection process. The y-axis shows the amount in liters

and x-axis the time in seconds. The amount of water saved is calculated from the flow rate per minute. The graph shows that the amount of water saved increases as the time passes.

At the end of thermal rejection process, around 4.5 liters of water is saved.

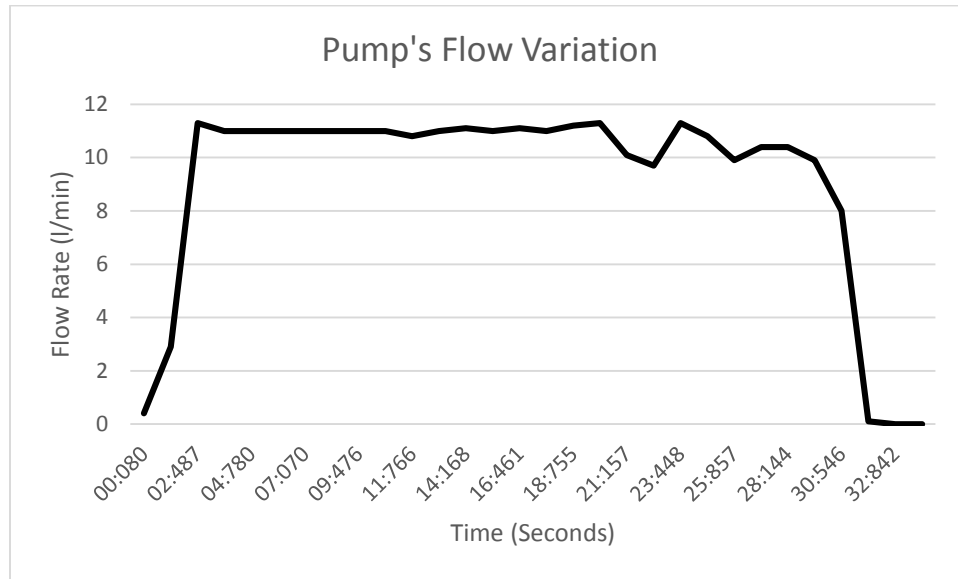

Figure 5-4: Flow rate during Thermal Rejection Process

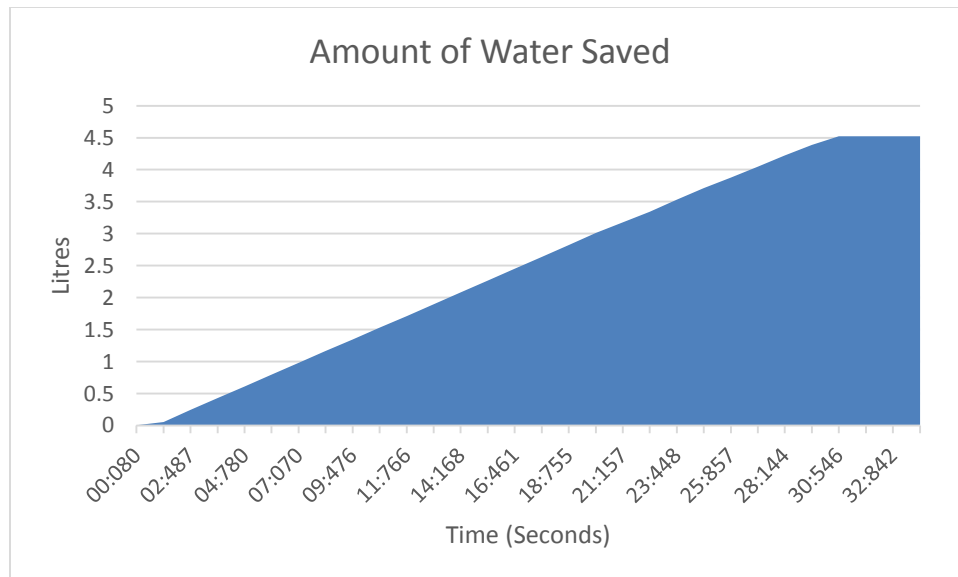

Figure 5-5: Total Amount of water saved during the thermal rejection process

5.4 Tank-based Experimental Results

Figure 5-6 shows the temperature variation at the heater's outlet and the user's endpoint during the winter mode operation. The x-axis displays the time in seconds and milliseconds and the y-axis displays the temperature in degree Celsius. When the rejection process is started, the temperature at the heater's outlet and the user's endpoint is 30.56 °C and 25.75 °C respectively. As hot water is pushed out of the heater, the temperature at the outlet starts to rise till it reaches 52.44 °C. As the rejection process goes on, the temperature of the hot water then starts to fall. This because water is pushed out at a faster rate from the heater than which it can be heated up. At the end of the rejection process, the temperature at the heater's outlet is 48.88 °C. The temperature at the user's end remains the same for about 20 seconds. This is because all the water in the pipe is at the same temperature. It's only after this water is rejected to the tank that the temperature starts to rise. At the end of the rejection process, the temperature at the user's end has risen to 45.5 °C. The whole winter mode operation of the rejection takes about 31 seconds. As similar to the tank-less thermal rejection, the graph does reflect the realistic operation. The temperature at the user's end should have a sharp increase compared to the gradual increase seen in the prototype. This is due to the prototype design not the system design. The long winded pipe the carries hot water to the user is only cold inside the bucket. There are parts of the hot water line which are not cold and this causes the described behavior of the temperature variation. The drawback of this behavior is that after the thermal rejection process is completed, the part of the cold line from the user to the tee will contain warm water. It is expected that such behavior will not occur in a real time deployment of the thermal rejection system

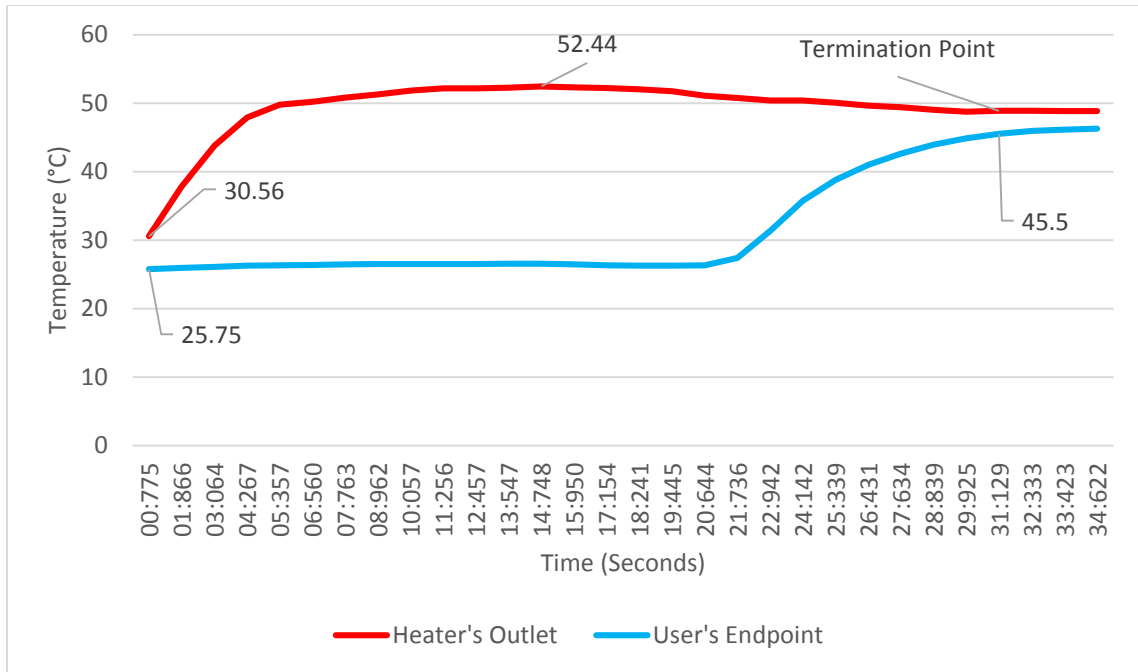

Figure 5-6: Temperature variation during Winter Mode Operation

Figure 5-7 shows the flow rate of water through the rejection line during the winter mode operation. The flow rate averages to about 10. l/min during the rejection process. The two spikes on the graph are at the times when the rejection process is initiated and stopped. Figure 5-8 shows the amount of water saved during the rejection process. This is calculated from the flow rate of the water in the reject line. A total of 4.8 liters is saved using the winter operation mode.

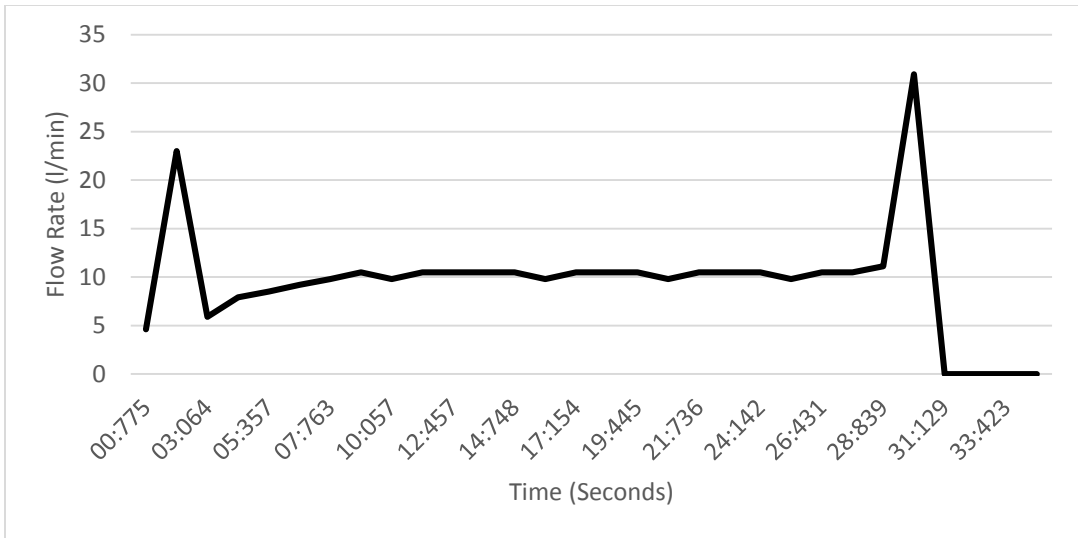

Figure 5-7: Flow Rate in the Rejection Line during Winter Mode Operation

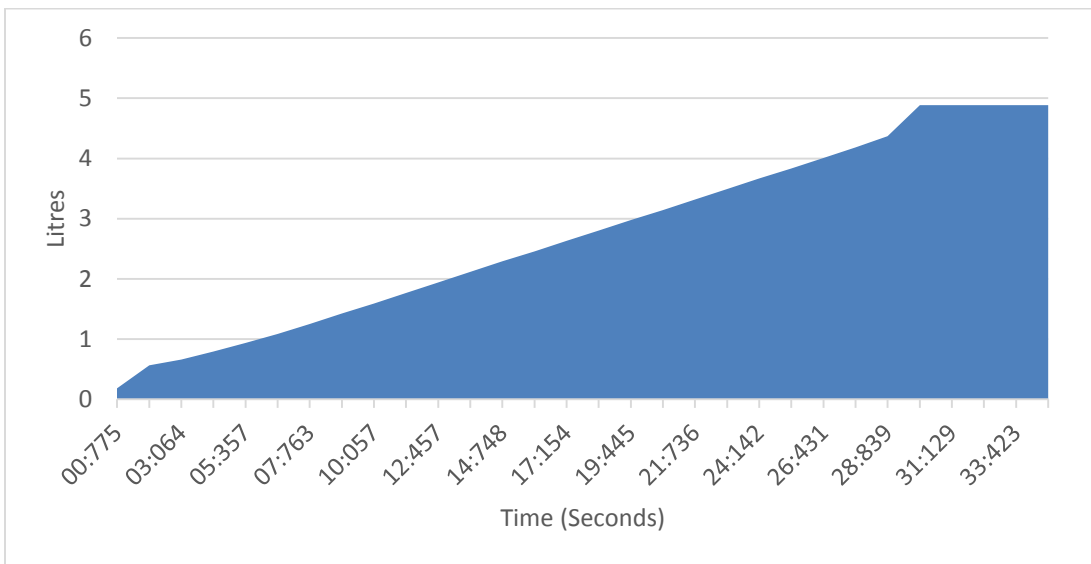

Figure 5-8: Amount of Water saved and circulated back to the Tank during Winter Mode Operation

5.5 Water Saving Estimation

Saudi Arabia's climate is marked by extreme hot summer and mildly cold winter. The Figure 5-9 displays the climate data [29] for the city of Dhahran which is known for its humid summer and mild winter. It can be seen that for the months from November to April

that the daily mean is less than 25 °C. Therefore, for the period of 6 months the rejection process done in the experiment can be applied.

Climate data for Dhahran, Saudi Arabia													
Month	Jan	Feb	Mar	Apr	May	Jun	Jul	Aug	Sep	Oct	Nov	Dec	Year
Record high °C (°F)	30 (86)	36.2 (97.2)	38.8 (101.8)	45 (113)	49.5 (121.1)	49 (120)	49 (120)	48.5 (119.3)	46.6 (115.9)	44.5 (112.1)	37.5 (99.5)	31 (88)	49.5 (121.1)
Average high °C (°F)	20.8 (69.4)	22.3 (72.1)	25.6 (78.1)	32.4 (90.3)	38.7 (101.7)	41.7 (107.1)	43.3 (109.9)	42.4 (108.3)	40.3 (104.5)	35.6 (96.1)	28.9 (84)	23.2 (73.8)	32.93 (91.28)
Daily mean °C (°F)	15.5 (59.9)	16.7 (62.1)	20.6 (69.1)	25 (77)	30.6 (87.1)	33.4 (92.1)	35.2 (95.4)	34.4 (93.9)	31.9 (89.4)	27.9 (82.2)	22.3 (72.1)	17 (63)	25.88 (78.61)
Average low °C (°F)	10.2 (50.4)	11.5 (52.7)	14.7 (58.5)	19.7 (67.5)	24.6 (76.3)	27.5 (81.5)	28.9 (84)	28.7 (83.7)	25.6 (78.1)	22 (72)	17.1 (62.8)	12.4 (54.3)	20.24 (68.48)
Record low °C (°F)	-1 (30)	3 (37)	6 (43)	10 (50)	14 (57)	19.4 (66.9)	21 (70)	19.5 (67.1)	18.5 (65.3)	13.4 (56.1)	8 (46)	3.4 (38.1)	-1 (30)
Average precipitation mm (inches)	17.7 (0.697)	15.2 (0.598)	35.3 (1.39)	3.5 (0.138)	1.2 (0.047)	0 (0)	0 (0)	0 (0)	0 (0)	0.3 (0.012)	18.6 (0.732)	15.7 (0.618)	107.5 (4.232)
Avg. precipitation days	11	9.7	16.2	7.6	2.2	0.1	0.1	0	0.1	0.6	4.9	10.2	62.7
Average relative humidity (%)	73	68	60	55	43	34	36	44	53	60	64	66	54.7

Figure 5-9: Climate Data for Dhahran

A telephonic survey [30] was done across 1000 randomly chosen households in Tasmania and the details of hot water usage i.e. the average number of shower taken daily. The results are shown in Figure 5-10. From the results, it can be inferred that a household family greater than two, will have the average number of showers equal to that of the number of the family members.

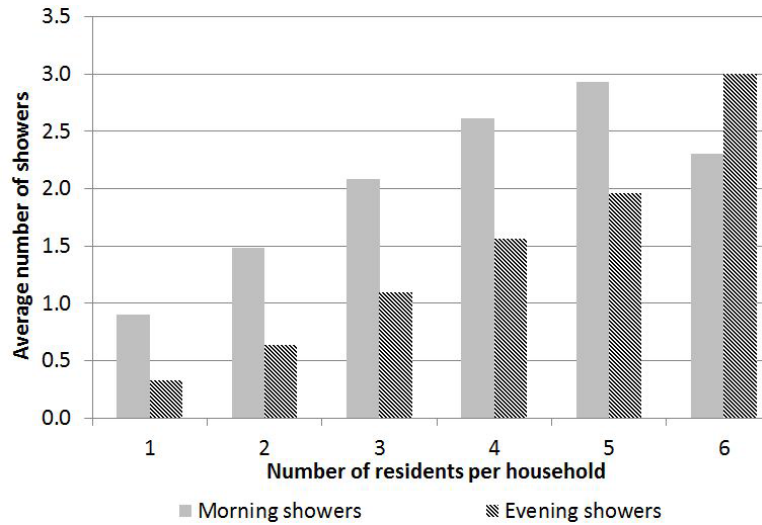

Figure 5-10: Average number of showers versus the number of residents per household [30]

Using the data from the above two figures and the amount saved during the rejection process, we can estimate the savings for a household family as shown in the Table 5-1. Anywhere between 1300 and 3300 liters can be saved just for one household for the duration of five months of winter.

Household Members	Number of Showers	Water Saved During Rejection Process (Litres)		
		Per Day	Per Month	5 Months
2	2	9	270	1350
3	3	13.5	405	2025
4	4	18	540	2700
5	5	22.5	675	3375

Table 5-1: Water Saving Estimates

CHAPTER 6

CONCLUSION AND FUTURE WORK

In this thesis, we presented an innovative solution to prevent common water wastage in homes. Water is wasted when it is not at the right temperature and it is let to flow down the drain. This occurs during both summer and winter when the pipes of the WDN are exposed to extreme temperatures. In order to save this water, we propose unique designs for the different WDN found in homes from those with and without tanks. Our system design is superior to the existing HWR systems as it is on-demand. The user initiates the thermal rejection process either by a push button or a motion sensor. system can be retrofitted to any building without much alteration. In these designs, we create an intelligent CPS that saves water by thermally rejecting unfit water back into the system until water at a comfortable temperature arrives. A prototype was then built based on the said designs using microcontrollers and solenoid valves. The prototype demonstrated successfully two designs of the rejection process. Data was collected using temperature and flow sensors during the thermal rejection process. The results indicate that significant amount of water is saved during the process and at the same time delivering optimal temperature water to the user within a short wait time.

In the future, the thermal rejection system can be installed in a home and real time data can be collected. Data such as the amount of water and the temperature of the water at which it is wasted can be recorded. The user interaction and behavior can also be used to improve the rejection system.

APPENDICES

APPENDIX A

IMAGES OF THE BUILT PROTOTYPE

This appendix contains the images of the prototype which was built using the hardware mentioned in the Chapter 5. The pipes were tape-colored to illustrate functions: blue for cold, red for hot and yellow for rejection.



Figure A-1: 64L Container as the Water Source



Figure A-2: Connection Leading from the Container to the Supply Pump



Figure A-3: Water Supply Mains Pump



Figure A-4: Solenoid Valve places after the Mains



Figure A-5: One Way Valve on the Supply line to Heater

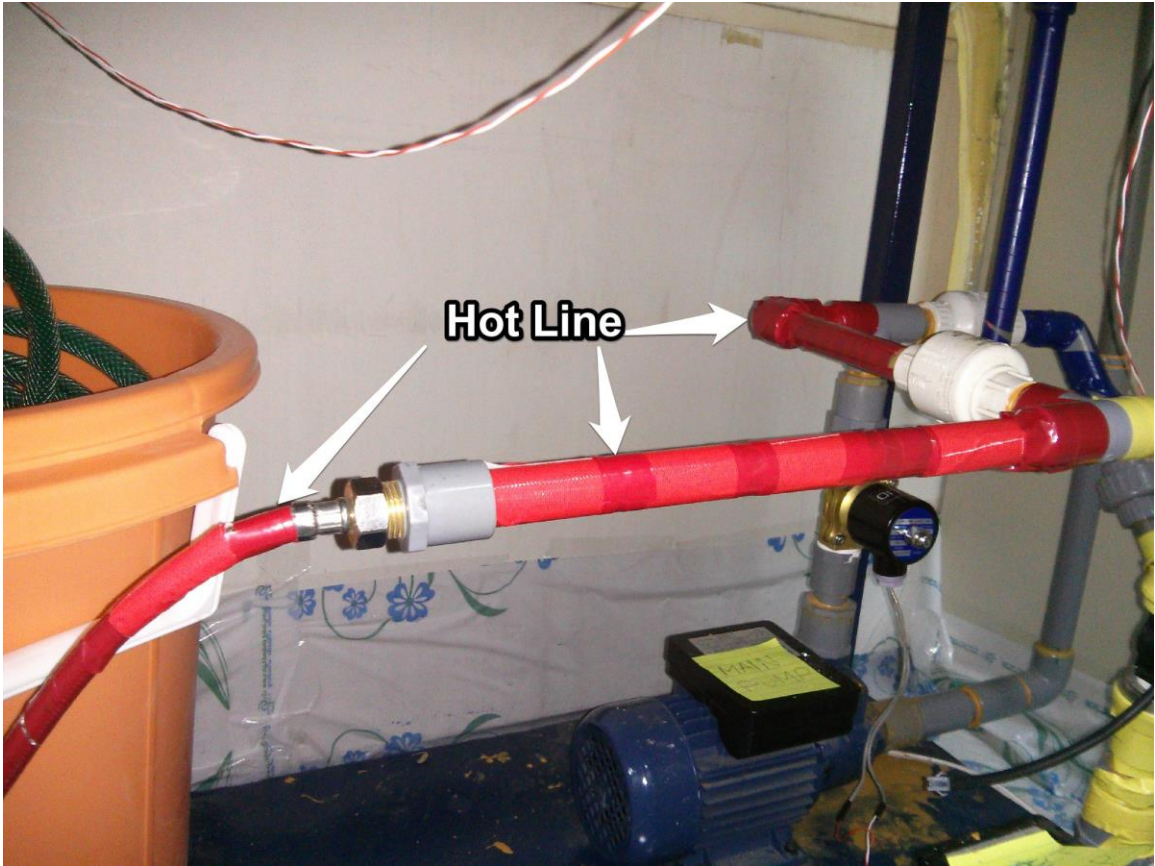

Figure A-6: Hot Water Supply Line

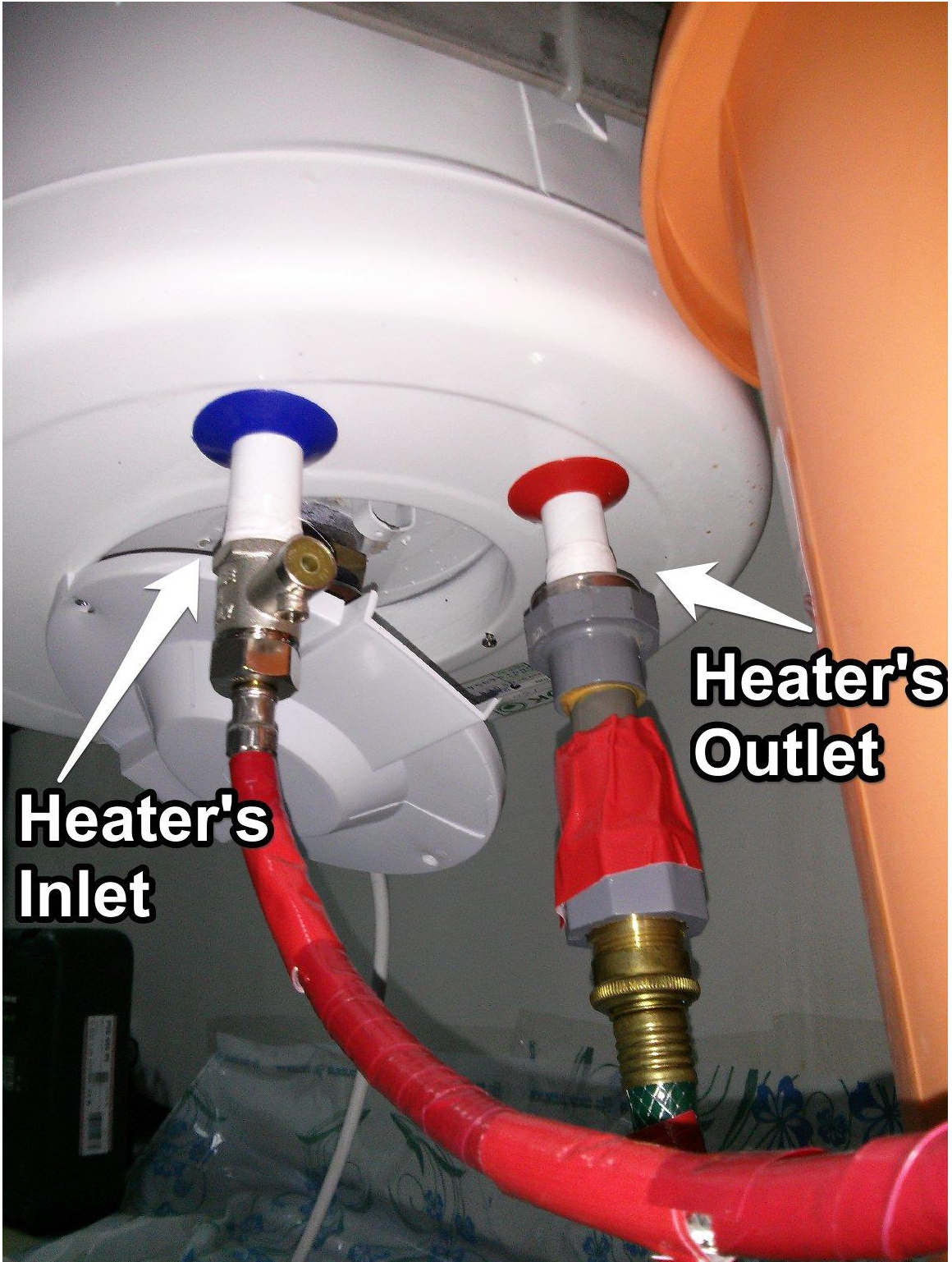

Figure A-7: Heater's Inlet (Blue) and Outlet (Red)



Figure A-8: Temperature Sensor Attached at Heater's Outlet



Figure A-9: Front View of the Water Heater



Figure A-10: Heater's Outlet connects to the 25m pipe inside the Orange Container

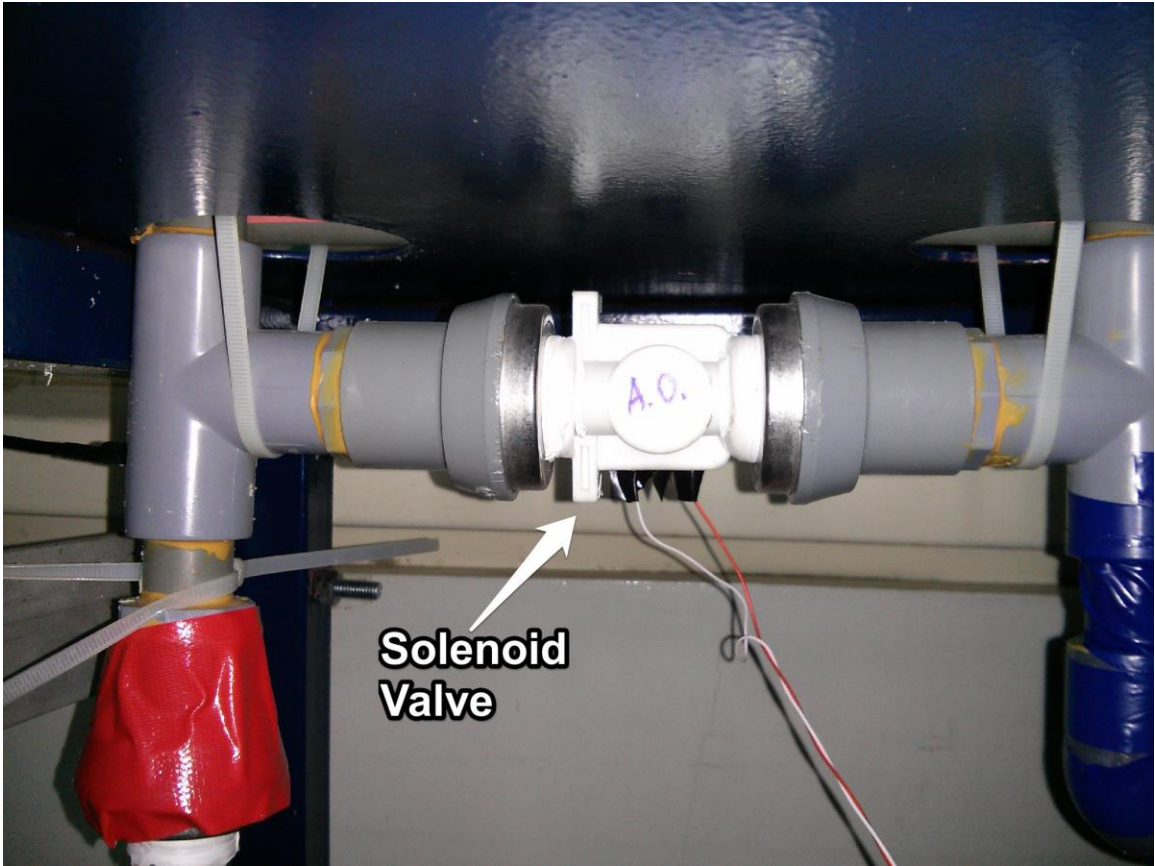

Figure A-11: Solenoid Valve at the User's End

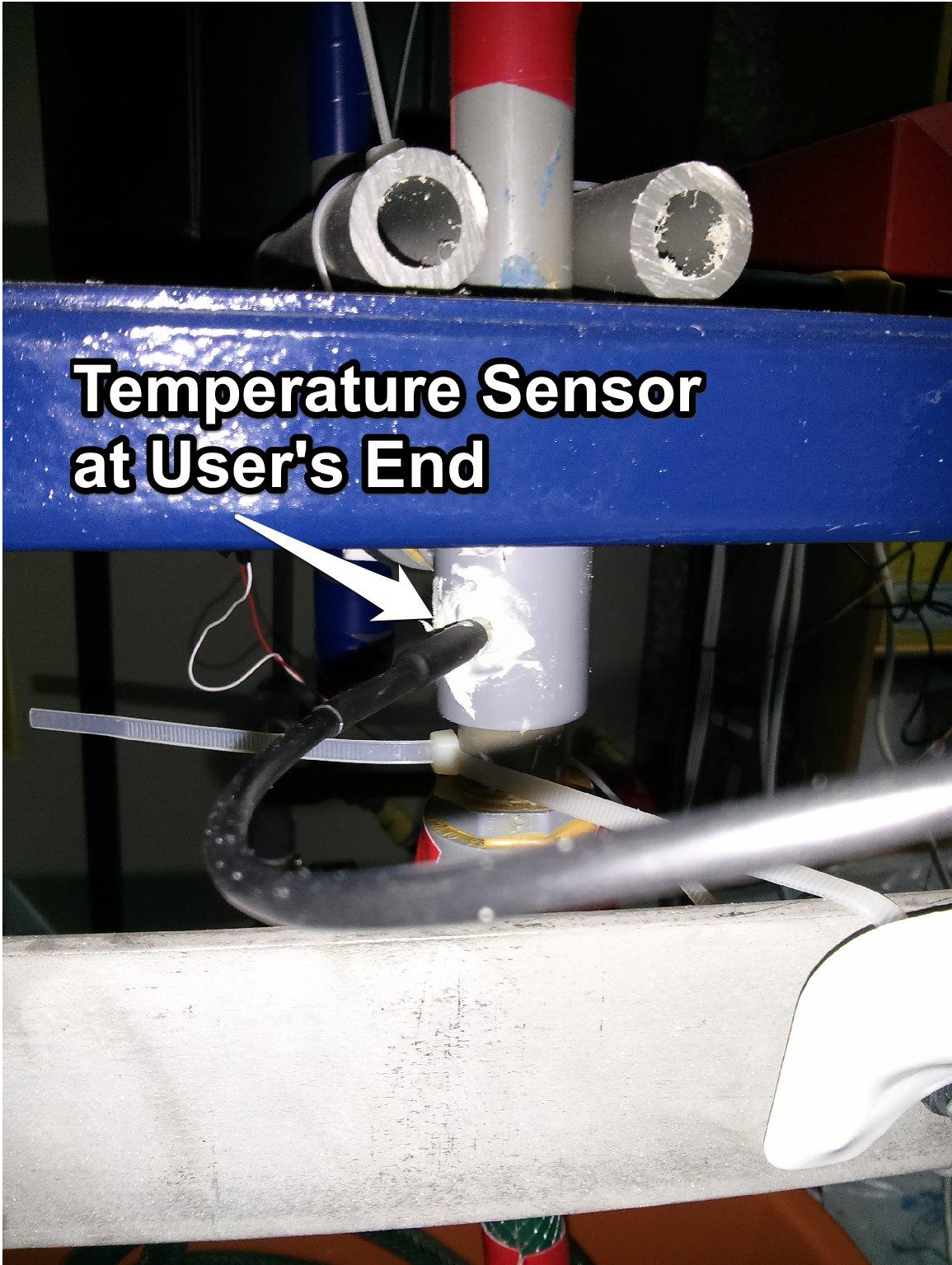

Figure A-12: Temperature Sensor at the User's End

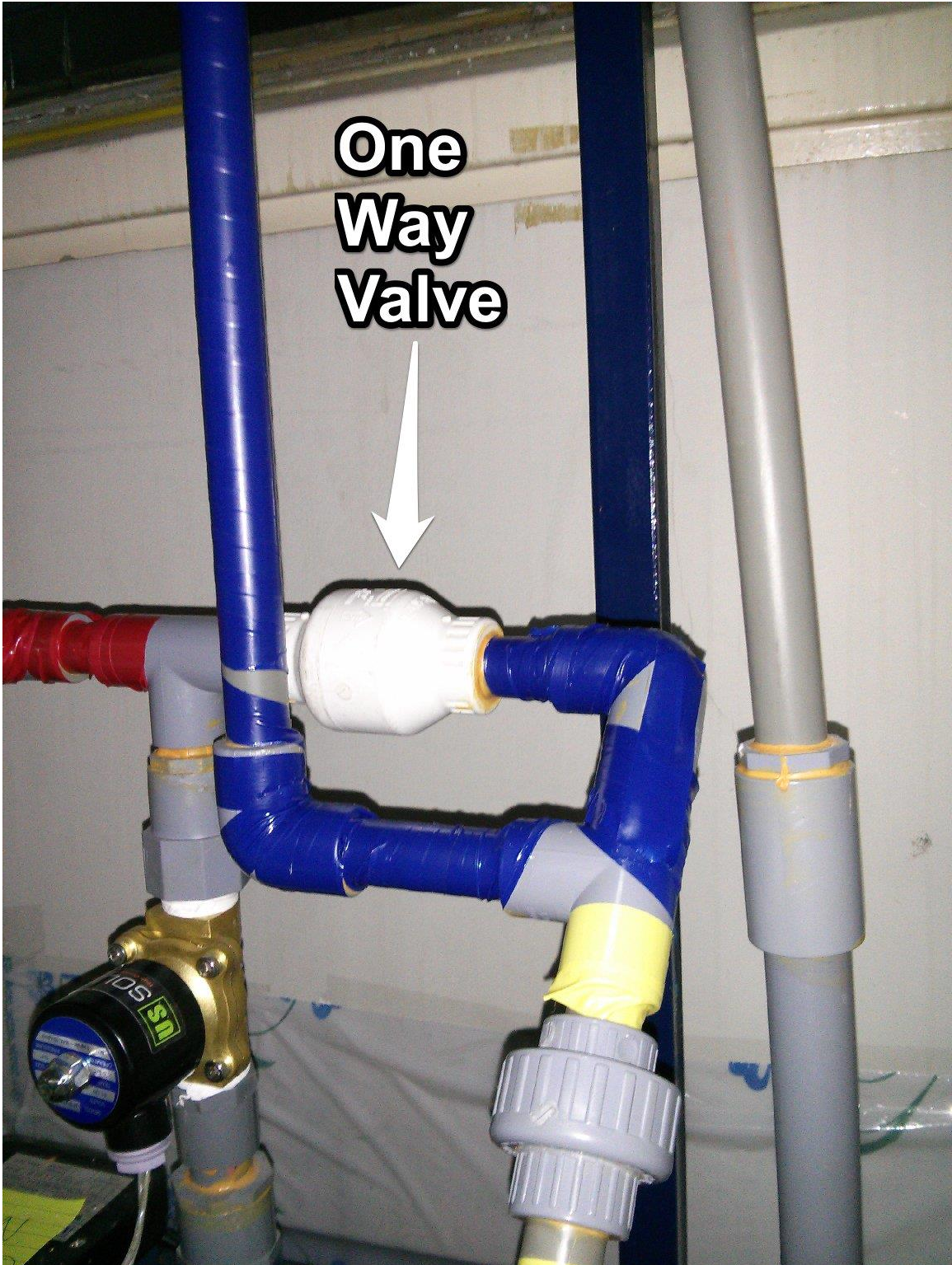

Figure A-13: One Way Valve on the Reject Loop

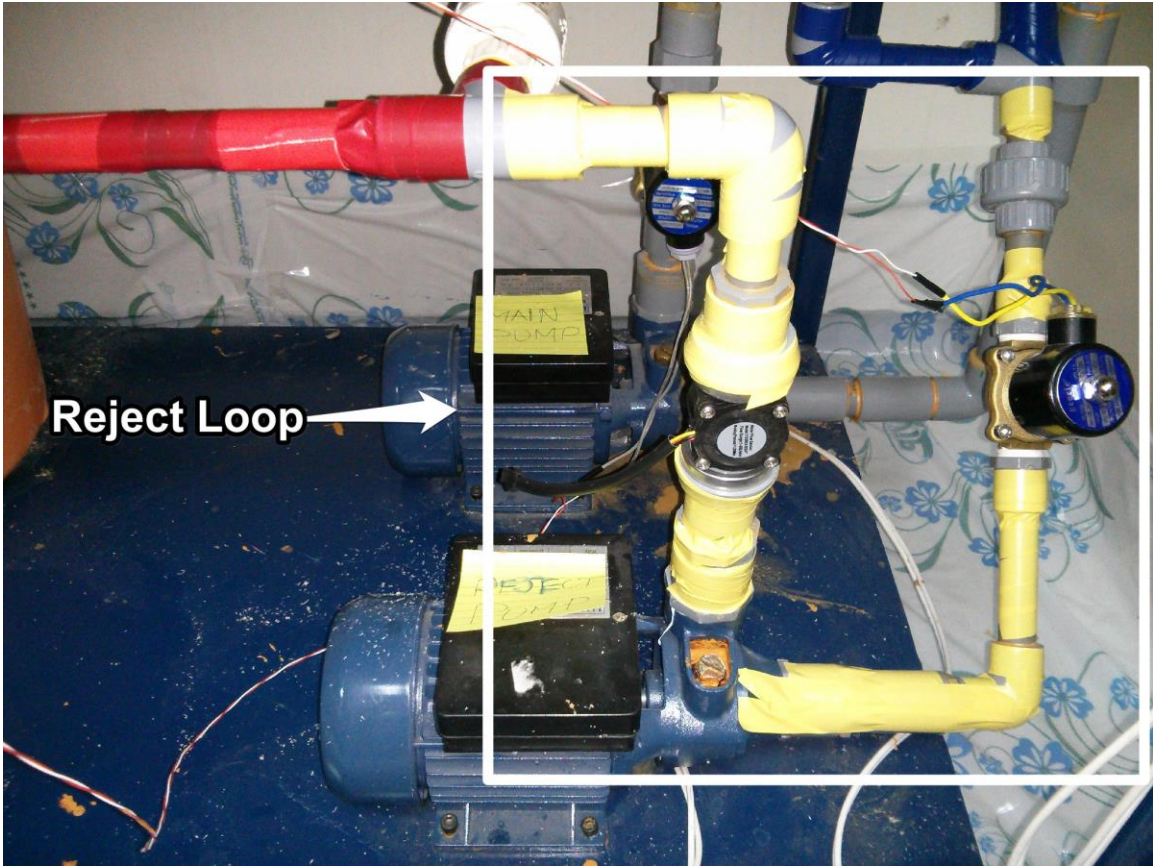

Figure A-14: Top View of the Reject Loop containing Solenoid Valve and Reject Pump



Figure A-15: Flow Meter installed on the outlet of the Reject Pump



Figure A-16: Side View of the Prototype



Figure A-17: Solenoid Valve and TEE on the cold line

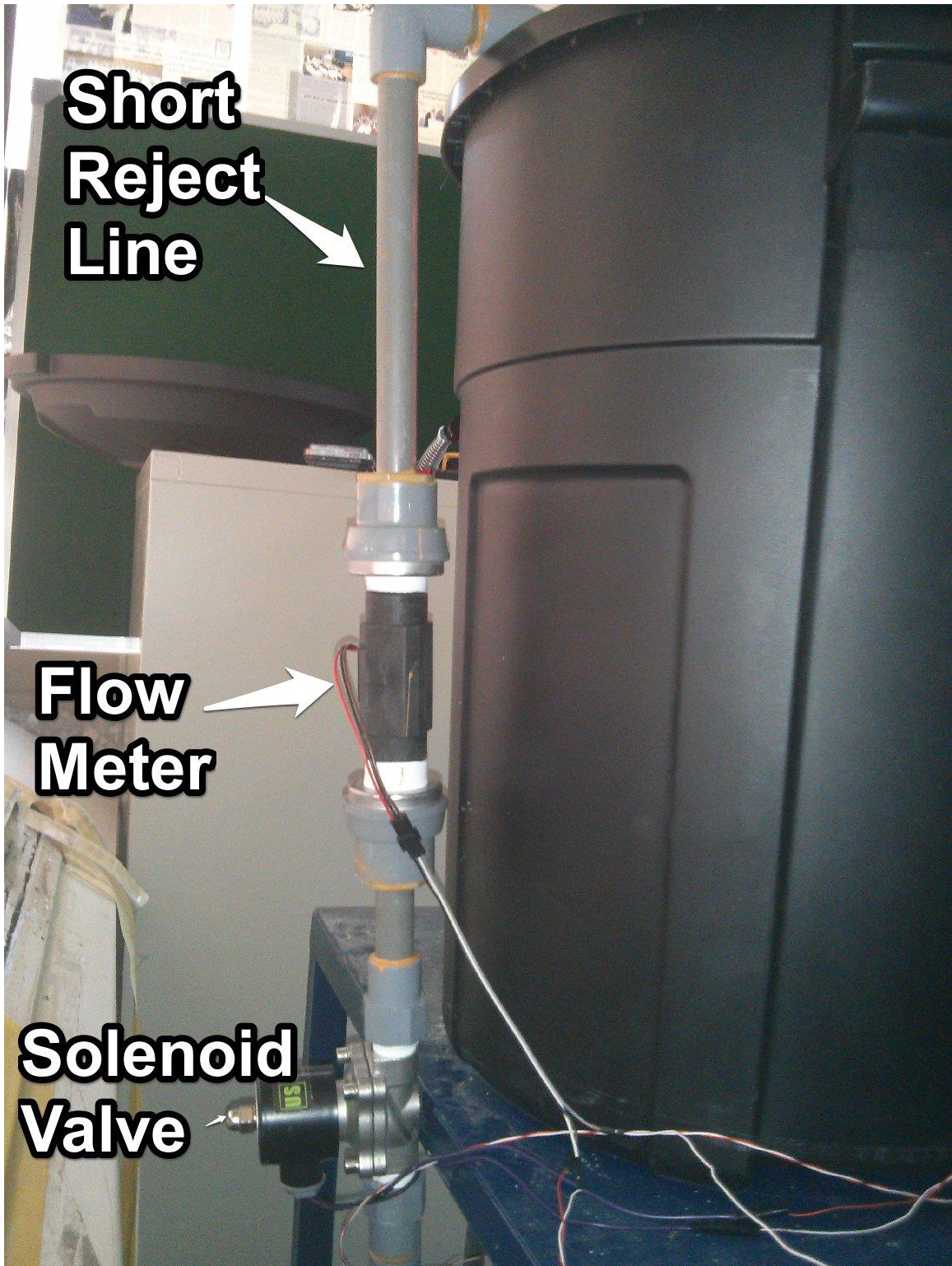

Figure A-18: Short Reject Line to the Tank containing a Solenoid Valve and a Flow Meter

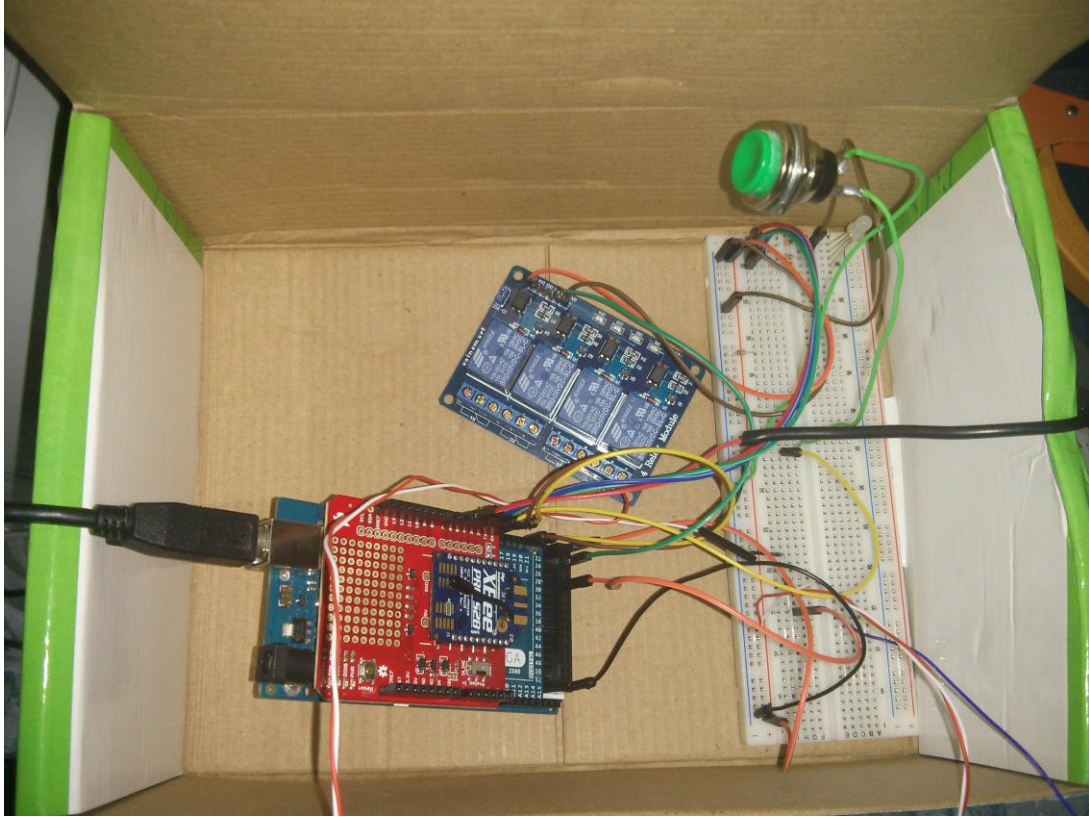

Figure A-19: Front Box with Arduino MEGA, XBEE PRO, RELAY and BUTTON

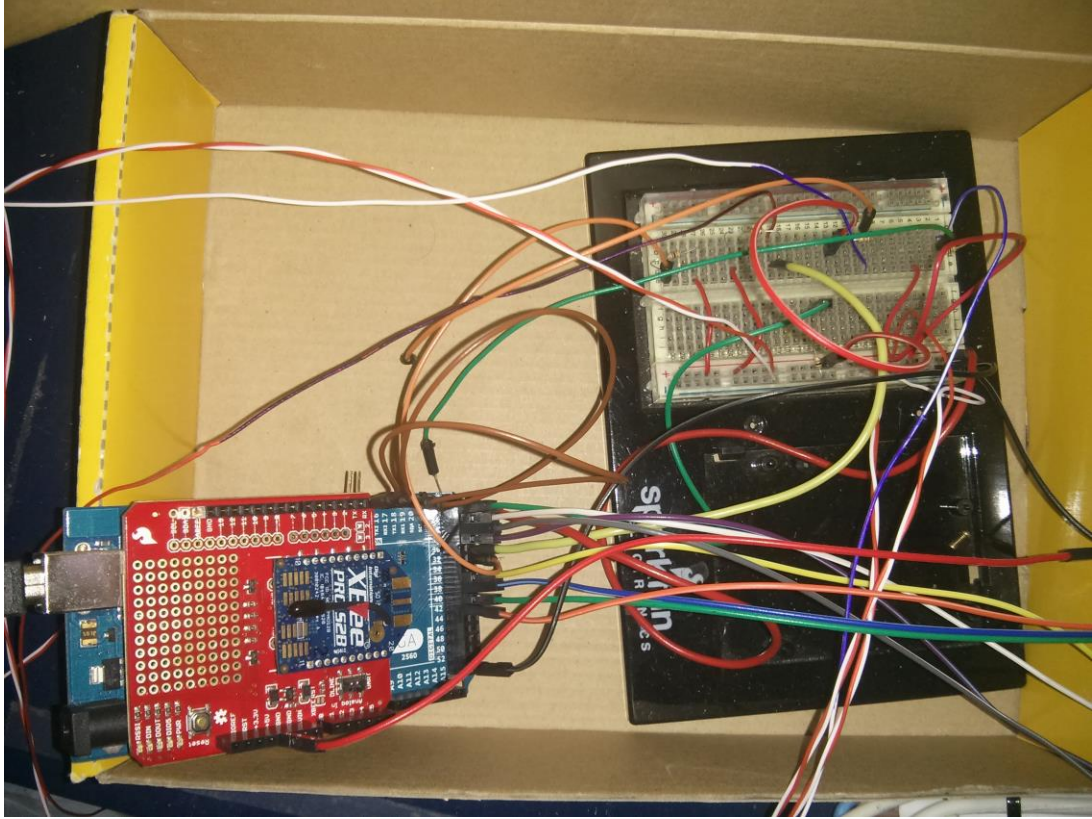

Figure A-20: Back Box with Arduino Mega and XBEE PRO

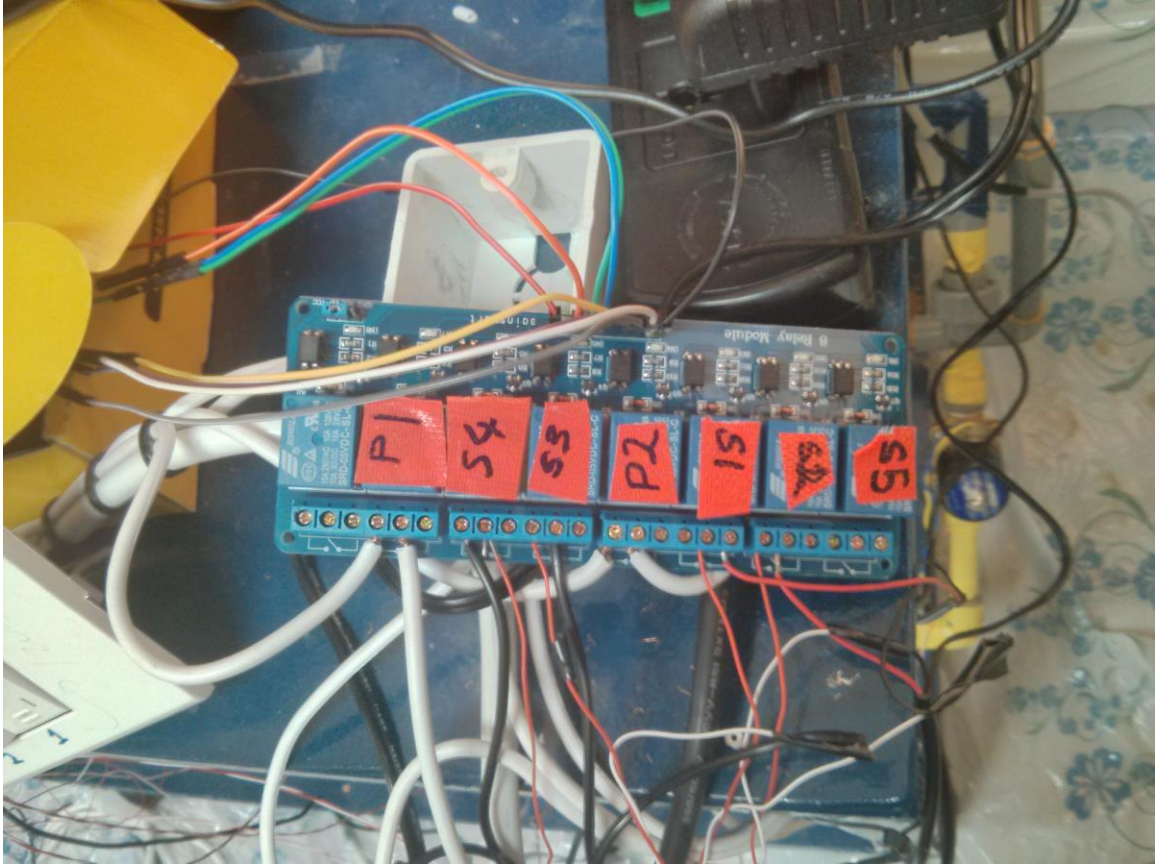

Figure A-21: Relay Board connected to Back Box

APPENDIX B

ARDUINO CODE

B.1 Front Box

```
//FrontBox.ino
#include <OneWire.h>

const int connectionLED = 13;      // the number of the LED pin
const int userTempPin = 30;       //DS18S20 Signal pin on digital
30

int redPin = 6;
int greenPin = 3;
int bluePin = 5;

#define RELAY1 24                  // the number of the first relay
control pin

int reject_state = 0;
const int buttonPin = 2;         // the number of the pushbutton pin
const int ledPin = 13;          // the number of the LED pin

// Variables:
```

```

int ledState = HIGH;           // the current state of the LED
int lastButtonState = LOW;    // the previous reading from the
button

int buttonState;              // the current reading from the
button

//The below variables are long as time is measured in
milliseconds

long debounceDelay = 50;     // the debounce time
long lastDebounceTime = 0;   // the last time the button was
toggled
long lastXbeeTime = 0;
long xbeetimeout = 3000;
long lastRejectTime = 0;
long rejectDelay = 10000;

float HeaterTemp = 0;
float UserTemp = 0;
float diffTemp = 0;
float Temp = 0;

//Temperature Function
OneWire ds1(userTempPin); // on digital pin 31

int count = 0;

```

```

void setup() {

    pinMode(buttonPin, INPUT);
    pinMode(connectionLED, OUTPUT);
    pinMode(RELAY1, OUTPUT);

    pinMode(greenPin, OUTPUT);
    pinMode(redPin, OUTPUT);
    pinMode(bluePin, OUTPUT);

    digitalWrite(RELAY1, LOW);

    Serial.begin(9600);
    Serial1.begin(9600);      //XBEE Serial Connection

}

void loop() {

    SwitchState();

    // Store the current time
    long currentTime = millis();

    //Perform the while if data is available from back box
    while (Serial1.available() > 0) {

```



```

int reading = digitalRead(buttonPin);

// Wait some time since the last press and then check
// if the button has been pressed otherwise just ignore

// Because of either noise or pressing, the state of the
button
// has changed.
if (reading != lastButtonState) {
    // reset the debouncing timer
    lastDebounceTime = millis();
}

if ((millis() - lastDebounceTime) > debounceDelay) {
    // If the reading has been the same longer
    // than the debounce delay, then store it as the actual
current state:

    // if the button state has changed:
    if (reading != buttonState) {
        buttonState = reading;

        // If the button state is HIGH then set reject state to 1
        if (buttonState == HIGH) {

```

```

        ledState = !ledState;
        reject_state = 1;
        break; //exit the while loop
    }
}
}

// set the LED:
digitalWrite(ledPin, ledState);

//For the next loop save this reading as lastbuttonstate
lastButtonState = reading;

UserTemp = getTempUser();

if (UserTemp < 30) {
    setColor(0, 0, 255); // blue
} else if (UserTemp >= 40) {
    setColor(255, 0, 0); // red
}

Temp = Serial1.parseFloat();
if (Temp > 0 && Temp < 70) {
    HeaterTemp = Temp;
}

```

```

Serial.print(UserTemp);
Serial.print(",");
Serial.print(HeaterTemp);
Serial.print(",");
diffTemp = HeaterTemp - UserTemp;
// Serial.print("Difference:");
Serial.println(diffTemp);
if (reject_state == 1) {
    long rejectStartTime = millis();
    if ( rejectStartTime - lastRejectTime > rejectDelay ) {
        lastRejectTime = rejectStartTime;
        if ( diffTemp <= 6) {
            reject_state = 0;
        }
    }
}

lastXbeeTime = millis();
}

if (!Serial.available()) {

```

```

long xbeeTime = millis();

if (xbeeTime - lastXbeeTime > xbeetimeout) {
    lastXbeeTime = xbeeTime;
    reject_state = 0;
    SwitchState();
}
}
delay(1000); //Slow the output to make it easy to read
}

```

```

void SwitchState() {
    Serial.println(reject_state);
    switch (reject_state)
    {
        case 0:
            digitalWrite(RELAY1, LOW);
            Serial1.println("a");

            //      Serial.println("In Normal Mode.");
            break;
        case 1:
            digitalWrite(RELAY1, HIGH);
            Serial1.println("b");
    }
}

```

```

        //      Serial.println("In Rejection Mode.");
        break;
        /* case 1:
            digitalWrite(RELAY1, HIGH);
            Serial1.println("c");
            //      Serial.println("In Rejection Mode.");
            break;*/
    }

}

```

```

void setColor(int red, int green, int blue)
{
    analogWrite(redPin, red);
    analogWrite(greenPin, green);
    analogWrite(bluePin, blue);
}

```

```

float getTempUser() {
    //Temperature from DS18S20 is return in DEG Celsius

    byte data[12];
    byte addr[8];
}

```

```

if ( !ds1.search(addr)) {
    //reset search if no sensors are found
    ds1.reset_search();
    return -1000;
}

if ( OneWire::crc8( addr, 7) != addr[7]) {
    Serial.println("CRC is not valid!");
    return -1000;
}

if ( addr[0] != 0x10 && addr[0] != 0x28) {
    Serial.print("Device is not recognized");
    return -1000;
}

ds1.reset();
ds1.select(addr);
ds1.write(0x44, 1);

byte present = ds1.reset();
ds1.select(addr);
ds1.write(0xBE);

```

```

    for (int i = 0; i < 9; i++) {
        data[i] = ds1.read();
    }

    ds1.reset_search();

    byte MSB = data[1];
    byte LSB = data[0];

    float tempRead = ((MSB << 8) | LSB);
    float TemperatureSum = tempRead / 16;

    return TemperatureSum;

}

```

B.2 Back Box

```

//BackBox.ino
#include <OneWire.h>

const int heaterTempPin = 31; //DS18S20 Signal pin on digital 31
const int flowPin = 2;

```

```

#define RELAY1 24
#define RELAY2 26
#define RELAY3 28
#define RELAY4 36
#define RELAY5 38
#define RELAY6 40
#define RELAY7 42

// Variables
int ledState = HIGH;      // the current state of the LED
int reject_state = 0;

long lastXbeeTime = 0;
long xbeetimeout = 3000;

float HeaterTemp = 0;
float UserTemp = 0;
float diffTemp = 0;

//Temperature Function
OneWire ds1(heaterTempPin); // on digital pin 31

byte sensorInterrupt = 1; // 0 = pin 2; 1 = pin 3
// The 1 ince hall-effect flow sensor calibration factor is given
below

```



```

float calibrationFactor = 1.3;

volatile byte pulseCount;

float flowRate;
unsigned int flowMilliLitres;
unsigned long oldTime;
unsigned long totalMilliLitresA;

void setup() {
  pinMode(RELAY1, OUTPUT);
  pinMode(RELAY2, OUTPUT);
  pinMode(RELAY3, OUTPUT);
  pinMode(RELAY4, OUTPUT);
  pinMode(RELAY5, OUTPUT);
  pinMode(RELAY6, OUTPUT);
  pinMode(RELAY7, OUTPUT);

  //and the interrupt is attached to the flow sensor
  attachInterrupt(sensorInterrupt, pulseCounter,RISING);

  pulseCount      = 0;
  flowRate        = 0.0;

```

```

    flowMilliLitres    = 0;
    totalMilliLitresA = 0;

    oldTime            = 0;

    digitalWrite(RELAY1, LOW);
    digitalWrite(RELAY2, HIGH);
    digitalWrite(RELAY3, HIGH);
    digitalWrite(RELAY4, HIGH);
    digitalWrite(RELAY5, HIGH);
    digitalWrite(RELAY6, HIGH);
    digitalWrite(RELAY7, HIGH);

    Serial.begin(9600);
    Serial1.begin(9600);
}

void loop() {

    HeaterTemp = getTempHeater();
    // Serial.print(" Heater Temperature: ");
    Serial1.println(HeaterTemp);
    Serial.println(HeaterTemp);
    //Serial.print(", ");
    delay(10);
}

```

```

WaterFlow();

while (Serial1.available() > 0) {
    char c = Serial1.read();    //Read the character state sent
    by Front Box
    Serial.print(c);

    switch (c) {
        case 'a':
            reject_state = 0;
            SwitchState();
            break;
        case 'b':
            reject_state = 1;
            SwitchState();
            break;
        /* case 'c':
            reject_state = 1;
            SwitchState();
            break;
        */
    }

    lastXbeeTime = millis();

```

```

}

if (!Serial.available()) {
    long xbeeTime = millis();

    if (xbeeTime - lastXbeeTime > xbeetimeout) {
        lastXbeeTime = xbeeTime;
        reject_state = 0;
        SwitchState();
    }
}

delay(500); //Slow the output make it easier to read
}

```

```

void SwitchState() {
    switch (reject_state)
    {
        case 0:
            digitalWrite(RELAY1, LOW);
            digitalWrite(RELAY2, HIGH);
            digitalWrite(RELAY3, HIGH);
            digitalWrite(RELAY4, HIGH);
            digitalWrite(RELAY5, HIGH);
            digitalWrite(RELAY6, HIGH);

```

```
    digitalWrite(RELAY7, HIGH);  
    //      Serial.println("In Normal Mode.");  
    break;  
case 2:  
    digitalWrite(RELAY1, HIGH);  
    digitalWrite(RELAY2, LOW);  
    digitalWrite(RELAY3, LOW);  
    digitalWrite(RELAY4, LOW);  
    digitalWrite(RELAY5, LOW);  
    digitalWrite(RELAY6, HIGH);  
    digitalWrite(RELAY7, HIGH);  
    //      Serial.println("In Rejection Mode.");  
    break;  
case 1:  
    digitalWrite(RELAY1, HIGH);  
    digitalWrite(RELAY2, HIGH);  
    digitalWrite(RELAY3, HIGH);  
    digitalWrite(RELAY4, HIGH);  
    digitalWrite(RELAY5, LOW);  
    digitalWrite(RELAY6, LOW);  
    digitalWrite(RELAY7, LOW);  
    //      Serial.println("In Rejection Mode.");  
    break;  
}
```

```

}

void WaterFlow() {
  if((millis() - oldTime) > 1000)    // The counter is processed
  once per second
  {
    // The interrupt is disabled while calculating the flow rate
    detachInterrupt(sensorInterrupt);

    //The number of milliseconds is calculated since the last
    execution of this function

    // The output is scaled using that number and the calibration
    faction as well to

    // obtain the reading in liters/minute

    flowRate = ((1000.0 / (millis() - oldTime)) * pulseCount) /
    calibrationFactor;

    //We also note the time take for the above line to process.
    This will return the

    //value of time before it was interrupted.

    oldTime = millis();

    // The calculate flow rate is then divided by 60

    // This gives the amount of litres passed in the 1 second
    interval
  }
}

```

```

    // It is then multiplied by 1000 to get the value in
millilitres

    flowMilliLitres = (flowRate / 60) * 1000;

    // The millilitres is then added to the cumulative total
totalMilliLitresA += flowMilliLitres;

    //The calculated value is then printed to the serial port in
order to display

    //with floating point
    unsigned int frac;

    // Print the flow rate for this second in litres / minute
    Serial.print(int(flowRate)); // Print the integer part of
the variable
    Serial.print(".");           // Print the decimal point
    // Determine the fractional part. The 10 multiplier gives us
1 decimal place.
    frac = (flowRate - int(flowRate)) * 10;
    Serial.print(frac, DEC) ;    // Print the fractional part
of the variable

    // Print the number of litres flowed in this second
    Serial.print(" ");          // Output separator
    Serial.print(flowMilliLitres);

    // Print the cumulative total of litres flowed since starting

```

```

Serial.print(" ");          // Output separator
Serial.println(totalMilliLitresA);

// Reset the pulse counter so we can start incrementing again
pulseCount = 0;

// Enable the interrupt again now that we've finished sending
output
attachInterrupt(sensorInterrupt, pulseCounter, RISING);
}
}

//Invoked by interrupt0 once per rotation of the hall-effect
sensor.
void pulseCounter()
{
// Increment the pulse counter
pulseCount++;
}

float getTempHeater() {
//Temperature from DS18S20 is returned in DEG Celsius

```



```

byte data[12];
byte addr[8];

if ( !ds1.search(addr)) {
    //no more sensors on chain, reset search
    ds1.reset_search();
    return -1000;
}

if ( OneWire::crc8( addr, 7) != addr[7]) {
    Serial.println("CRC is not valid!");
    return -1000;
}

if ( addr[0] != 0x10 && addr[0] != 0x28) {
    Serial.print("Device is not recognized");
    return -1000;
}

ds1.reset();
ds1.select(addr);
ds1.write(0x44, 1);

byte present = ds1.reset();

```

```
ds1.select(addr);
ds1.write(0xBE);

for (int i = 0; i < 9; i++) {
    data[i] = ds1.read();
}

ds1.reset_search();

byte MSB = data[1];
byte LSB = data[0];

float tempRead = ((MSB << 8) | LSB);
float TemperatureSum = tempRead / 16;

return TemperatureSum;

}
```

References

- [1] J. Bremner, A. Frost, C. Haub, M. Mather, K. Ringheim, and E. Zuehlke, *World Population Highlights: Key Findings From PRB's 2010 World Population Data Sheet*. Population Reference Bureau, 2010.
- [2] T. H. E. United and N. World, *Managing Water under Uncertainty and Risk*, vol. 1. .
- [3] A. A. ALUWAISHEG, "Runaway water consumption alarming for Saudi Arabia," *Arab News*, 2013. [Online]. Available: <http://www.arabnews.com/news/460158>.
- [4] L. Lamont, M. Toulgoat, M. D. Ezie, and G. Patterson, "Tiered Wireless Sensor Network Architecture for Military Surveillance Applications," in *SENSORCOMM 2011, The Fifth International Conference on Sensor Technologies and Applications*, 2011, pp. 288–294.
- [5] H. Yan, H. Huo, Y. Xu, and M. Gidlund, "Wireless sensor network based E-health system - Implementation and experimental results," *IEEE Trans. Consum. Electron.*, vol. 56, pp. 2288–2295, 2010.
- [6] S. E. Yoo, P. K. Chong, D. Kim, Y. Doh, M. L. Pham, E. Choi, and J. Huh, "Guaranteeing real-time services for industrial wireless sensor networks with IEEE 802.15.4," *IEEE Trans. Ind. Electron.*, vol. 57, pp. 3868–3876, 2010.
- [7] F. Ingelrest, G. Barrenetxea, G. Schaefer, M. Vetterli, O. Couach, and M. Parlange, "SensorScope: Application-specific sensor network for environmental monitoring," *ACM Trans. Sen. Netw.*, vol. 6, pp. 1–32, 2010.
- [8] E. A. Lee and S. A. Seshia, *Introduction to Embedded Systems, A Cyber-Physical Systems Approach*. 2011.
- [9] J. Gubbi, R. Buyya, S. Marusic, and M. Palaniswami, "Internet of Things (IoT): A vision, architectural elements, and future directions," *Futur. Gener. Comput. Syst.*, vol. 29, no. 7, pp. 1645–1660, Sep. 2013.
- [10] R. M. Willis, R. a. Stewart, K. Panuwatwanich, S. Jones, and A. Kyriakides, "Alarming visual display monitors affecting shower end use water and energy conservation in Australian residential households," *Resour. Conserv. Recycl.*, vol. 54, no. 12, pp. 1117–1127, Oct. 2010.

- [11] M. Lee, B. Tansel, and M. Balbin, "Influence of residential water use efficiency measures on household water demand: A four year longitudinal study," *Resour. Conserv. Recycl.*, vol. 56, no. 1, pp. 1–6, Nov. 2011.
- [12] B. Reddy and P. Eswaran, "Metro overhead tanks monitoring system using ZigBee based WSN," in *Information Communication Technologies (ICT), 2013 IEEE Conference on*, 2013, no. Ict, pp. 367–371.
- [13] L. Philip, V. S. Rakesh, P. R. Sreesh, N. R. Hemalatha, and C. V Raghu, "Electronic water supply management system for educational institutions," *2013 Int. Mutli-Conference Autom. Comput. Commun. Control Compress. Sens.*, pp. 73–77, Mar. 2013.
- [14] P.-V. Mekikis, G. Athanasiou, and C. Fischione, "A Wireless Sensor Network Testbed for Event Detection in Smart Homes," *2013 IEEE Int. Conf. Distrib. Comput. Sens. Syst.*, pp. 321–322, May 2013.
- [15] E. Thomaz, V. Bettadapura, G. Reyes, M. Sandesh, G. Schindler, T. Plotz, G. D. Abowd, and I. Essa, "Recognizing water-based activities in the home through infrastructure-mediated sensing," in *Proceedings of the 2012 ACM Conference on Ubiquitous Computing*, 2012, vol. UbiComp '11, pp. 85–94.
- [16] Y. Kim, T. Schmid, Z. M. Charbiwala, J. Friedman, and M. B. Srivastava, "NAWMS : Nonintrusive Autonomous Water Monitoring System," in *6th ACM conference on Embedded network sensor systems (SenSys '08)*, 2008, pp. 309–322.
- [17] Y. Kim, H. Park, and M. B. Srivastava, "A longitudinal study of vibration-based water flow sensing," *ACM Trans. Sens. Networks*, vol. 9, no. 1, pp. 1–28, Nov. 2012.
- [18] V. Srinivasan, J. Stankovic, and K. Whitehouse, "WaterSense: Water Flow Disaggregation Using Motion Sensors," in *Proceedings of the Third ACM Workshop on Embedded Sensing Systems for Energy-Efficiency in Buildings*, 2011, pp. 19–24.
- [19] T. Campbell, E. Larson, G. Cohn, J. Froehlich, R. Alcaide, and S. N. Patel, "WATTR: A Method for Self-powered Wireless Sensing of Water Activity in the Home," in *Proceedings of the 12th ACM International Conference on Ubiquitous Computing*, 2010, pp. 169–172.
- [20] P. Martin, Z. Charbiwala, and M. Srivastava, "DoubleDip: Leveraging Thermoelectric Harvesting for Low Power Monitoring of Sporadic Water Use," in *Proceedings of the 10th ACM Conference on Embedded Network Sensor Systems*, 2012, pp. 225–238.

- [21] J. Froehlich, E. Larson, T. Campbell, C. Haggerty, J. Fogarty, and S. N. Patel, "HydroSense: Infrastructure-Mediated Single-Point Sensing of Whole-Home Water Activity," in *Proceedings of the 11th international conference on Ubiquitous computing*, 2009, vol. 9, pp. 235–244.
- [22] A. Frye, M. Goraczko, J. Liu, A. Prodhan, and K. Whitehouse, "Circulo: Saving Energy with Just-In-Time Hot Water Recirculation," in *Proceedings of the 5th ACM Workshop on Embedded Systems For Energy-Efficient Buildings*, 2013, pp. 16:1–16:8.
- [23] "Hot Water Circulator on-Demand Circulation Recirculation Pump." [Online]. Available: <http://www.redytemp.com/>. [Accessed: 09-May-2015].
- [24] "Taco-Hvac." [Online]. Available: <https://www.taco-hvac.com/>. [Accessed: 09-May-2015].
- [25] "Enovative - AutoHot - On-Demand Recirculation Controls." [Online]. Available: <http://www.enovativegroup.com/>. [Accessed: 09-May-2015].
- [26] "Chilipepper Water Heater Pump and Hot Water Demand System Pump For Faster Hot Water!" [Online]. Available: <http://www.chilipepperapp.com/>. [Accessed: 09-May-2015].
- [27] J. AlSadah, "FLUID SUPPLY SYSTEM WITH TEMPERATURE CONTROL FOR FLUID CONSERVATION," Invention Disclosure, KFUPM Docket 36000.10.
- [28] "ZigBee." [Online]. Available: <https://en.wikipedia.org/wiki/ZigBee>. [Accessed: 13-May-2015].
- [29] *Climatological Information for Dhahran, Saudi Arabia*. Hong Kong Observatory.
- [30] M. Negnevitsky, "Development of an evaluation tool for demand side management of domestic hot water load," in *2013 IEEE Power & Energy Society General Meeting*, 2013, pp. 1–5.

Vitae

- Name : Mohammed Younus Siddiqui |
- Nationality : Indian |
- Date of Birth : 9/22/1987|
- Email : younus_siddiqui@yahoo.com|
- Address : 261/3rt, Vijayanagar Colony, Hyderabad-500057,
Telangana, India.|
- Academic Background : B.S. in Computer Science, (May, 2009) from Osmania
University, Hyderabad, Telangana, India. |
- Publications :
- **Mohammed Younus Siddiqui**, Faizuddin Mohammad, Ahmad Almulhem, "Supplementing Live Forensics with Traditional Forensics for Cloud Computing", *The 26th Annual IEEE Software Technology Conference (STC2014)*, Long Beach, California, USA, 29 March - 3 April 2014.
 - Mohammed H. Sqalli, Mohammed Al-saeedi, Farid Binbeshr, and **Mohammed Siddiqui**, "UCloud: A Simulated Hybrid Cloud for A University Environment", *The 1st IEEE International Conference on Cloud Networking (IEEE CLOUDNET 2012)*, Paris, France, November 28-30, 2012.