

# A COMPUTERIZED FORECASTING SYSTEM FOR STUDENT ENROLLMENT IN KFUPM

**M.F.S. Pulak, Mamdouh M. Najjar and Ahmad A. Al-Dharrab**

King Fahd University of Petroleum & Minerals, Dhahran, Saudi Arabia

**ABSTRACT.** Any higher education institute like a university should have a tentative future plan. The first step in establishing such a plan is to get the required information concerning the projected student enrollment for the next few years. Though an enrollment forecasting is a specific type of estimation - one that uses past information in some manner to arrive at an estimate of future enrollments. The basic assumptions are that some historical pattern exists, that this pattern can be identified and data can be collected to measure it, and that it reflects what is to occur in the future. In this paper, we will show a systematic analysis of students data to identify the hidden historical pattern and its important parameters which is essential for the forecasting. A computer program will be developed based on that historical pattern. The computer program then can be used as a powerful simulation tool to project the future enrollment.

## 1. INTRODUCTION

National center for Higher Education Management Systems (NCHEMS) at Western Interstate Commission on Higher Education (WICHE) have published a number of articles on the subject student enrollment forecasting for an institution of higher education. There are some other individuals who also worked in this area (for example see Gardner[1], Lins[2], Mangelson et al.[3], Parker[4], Parker et al.[5], Saddarth[7], Wing[8], Harvey[9], Mcknight[10]). Most forecasting methods can be categorized within four basic types:

### 1.1 Pattern-Based

Methods in this category attempt to identify an underlying pattern in historical data, described in mathematical terms and then extrapolate it into the future. Specific examples range in complexity from simple averaging and ratio methods to cohort survival, Markov - chain, and various curve fitting formulas.

### 1.2 Correlation Analysis

This approach is based on the numerical values of important indicator variables which have been demonstrated e.g., through the use of multiple regression to have a strong relationship to enrollment level. Commonly used methods express the enrollment as a percentage of high school graduates, the population in a specific age group, or births in a specified earlier period.

### 1.3 Intention Surveys

Intention surveys involve sampling specific groups to determine college attendance plans. Although this method can be relatively costly, it has been shown to be useful and reliable in some situation, as demonstrated by Russel & Hoffman[6].

### 1.4 Professional Judgment

Although this is probably the most commonly used approach, it is perhaps the most underrated. The lack of objectivity of this method may be more than offset by the benefit of experienced judgment and interpretation of subtle factors influencing enrollment not easily captured by mathematical models.

## 2. DEMERITS OF PATTERN-BASED & CORRELATION ANALYSIS METHOD

Because of the abundance and inherent complexity of factors influencing university enrollments, pattern based and correlation based forecasting must always be used with caution. These methods starts with the generally erroneous assumption that the observed pattern will continue into the future. Pinpoint accuracy is not be expected and, when it occurs, should be viewed as coincidental and suspect. Severe impending discontinuities in the underlying pattern will not be anticipated by any pattern - based formula.

## 3. PROPOSED METHOD

In spite of the shortcomings stated above in the pattern based method- it provides a baseline estimate of future data. That is why we will incorporate a pattern based method in our work and at the same time to overcome the limitations of this method we will provide option for professional judgment. Therefore the proposed method is a mixture of Pattern based method and professional judgment method. The proposed method is pattern based in the sense that it attempts to find a existing historical pattern in student enrollment data through data analysis. A computer program can be developed based on the identified historical pattern. But the dynamic future may not always follow the past historical pattern. Considering this, the computer program will be made interactive so that a professional judgment can also be incorporated in the program.

## 4. DATA ANALYSIS AND FORECASTING METHODOLOGY

To maintain high quality education and research, historically the total number of new admissions in KFUPM have been essentially controlled. Therefore an input is required for the proposed method for the total number of new students. Most of the new students are admitted into the Prep-Year (PY) class while rest of them are admitted directly into Freshman (FR) class. If we concentrate same consecutive term semesters (i.e. all fall semesters or all winter semesters) for the one Prep-Year, four undergraduate classes and one graduated students, a six by six (6X6) matrix is produced where the  $X_{i,j}$ 's are student enrollments by class (see Table-1). Where  $i$  refers to term. For example  $i=1$  means 911 term;  $i=2$  means 921 terms and so on. Similarly  $j$  refers to class. So  $j=0$  means Prep-Year (PY) class,  $j=1$  means Freshman (FR) class and so on.

Table 1. Student enrollment by class

Term	PY	FR	SO	JR	SR	GR
911	$X_{1,0}$	$X_{1,1}$	$X_{1,2}$	$X_{1,3}$	$X_{1,4}$	$X_{1,5}$
921	$X_{2,0}$	$X_{2,1}$	$X_{2,2}$	$X_{2,3}$	$X_{2,4}$	$X_{2,5}$
931	$X_{3,0}$	$X_{3,1}$	$X_{3,2}$	$X_{3,3}$	$X_{3,4}$	$X_{3,5}$
941	$X_{4,0}$	$X_{4,1}$	$X_{4,2}$	$X_{4,3}$	$X_{4,4}$	$X_{4,5}$
951	$X_{5,0}$	$X_{5,1}$	$X_{5,2}$	$X_{5,3}$	$X_{5,4}$	$X_{5,5}$
961	$X_{6,0}$	$X_{6,1}$	$X_{6,2}$	$X_{6,3}$	$X_{6,4}$	$X_{6,5}$

The 6X6 matrix of historical information in Table-1 provides a way of developing estimates of future enrollments. Students who failed to promote to the next class will be called retained student (RX). RX will be calculated as follows:

$$RX_{i,2} = X_{i-1,2} - X_{i,3} \tag{1}$$

In fact RX is a mixture of failed , readmitted , dropout and transfer students. In KFUPM, failed students mostly contribute in RX. Now a reasonable assumption would be that the student enrollment in a classification level is the function of the student enrollment of the prior classification level and the enrollment of the retained student from the same classification level for the previous semester (see Appendix A).

Concentrating on the matrix of the sophomore level students, the historical 6x5 matrix enables the following estimation equations to be used:

$$\begin{aligned} X_{2,2} &= A_2 X_{1,1} + B_2 RX_{2,2} \\ X_{3,2} &= A_2 X_{2,1} + B_2 RX_{3,2} \\ X_{4,2} &= A_2 X_{3,1} + B_2 RX_{4,2} \\ X_{5,2} &= A_2 X_{4,1} + B_2 RX_{5,2} \\ X_{6,2} &= A_2 X_{5,1} + B_2 RX_{6,2} \end{aligned} \tag{2}$$

In general we can write following equation :

$$X_{i,2} = A_2 X_{i-1,1} + B_2 RX_{i,2} + NX_{i,2} \tag{3}$$

A<sub>2</sub> and B<sub>2</sub> can be estimated by least squares method if RX and NX are known. NX is the total number of directly admitted new students. For KFUPM, values of NX<sub>i,2</sub> , NX<sub>i,3</sub> and NX<sub>i,4</sub> are zero (0) because normally there are no provision of direct new admission to classes upper than the freshman level. Using equation (1) RX can be estimated by the following way:

$$\begin{aligned} \%RX_{i,2} &= RX_{i,2} / X_{i-1,2} * 100 \\ \text{where } i &= 1,2,3,4,5,6 \end{aligned} \tag{4}$$

From KFUPM, it has been observed that %RX<sub>i,2</sub> is reasonably stable for the last few terms. Due to this reason, for the purpose of forecasting, we will assume that the most recent value of %RX<sub>i,2</sub> will also be stable for the next few terms. So, the most recent result will be used as an estimate of RX for forecasting. Here most recent value of %RX<sub>i,2</sub>=%RX<sub>6,2</sub> . therefore :

$$\begin{aligned} RX_{i,2} &= \%RX_{6,2} * X_{i-1,2} \\ \text{where } i & \geq 6 \end{aligned} \tag{5}$$

Thus the anticipated major enrollment for the sophomore class would be:

$$\begin{array}{l}
X_{7,2} = A_2 X_{6,1} + B_2 RX_{6,2} \\
X_{8,2} = A_2 X_{6,1} + B_2 RX_{6,2} \\
X_{9,2} = A_2 X_{6,1} + B_2 RX_{6,2} \\
----- \\
-----
\end{array} \quad (6)$$

and continuing as many equations is necessary in accord with the desired span of enrollment.

Now to make the above procedure general for any classes we can write the following equation :

$$\begin{aligned}
X_{i,j} &= A_i X_{i-1,j-1} + B_i RX_{i-1,j} + NX_{i,j} & (7) \\
&\text{where } i=2,3,4,5,6 \text{ and } j=0,1,2,3,4
\end{aligned}$$

To make the above relation useful for forecasting still we need to estimate two unknown values of  $NX_{i,0}$  and  $NX_{i,1}$  which are the total number of directly admitted new students in Prep-Year and Freshman classes respectively.

$$NX_{i,1} = TNX_i - NX_{i,0} \text{ where } i=1,2,3,4,5,6 \quad (8)$$

$$\text{and } \%NX_{i,1} = (TNX_i - NX_{i,0}) / TNX_i * 100 \quad (9)$$

where  $TNX$  = Total number of directly admitted new students per year.

From KFUPM, it has been observed that like  $\%RX_{i,2}$ ,  $\%NX_{i,1}$  is also reasonably stable for the last few terms. Accordingly, for the purpose of forecasting, we will assume that the most recent value of  $\%NX_{i,1}$  will also be stable for the next few terms. So, most recent value of  $\%NX_{i,1}$  will be used as an estimate of  $NX_{i,1}$ . Here most recent value of  $\%NX_{i,1} = \%NX_{6,1}$ ; therefore

$$NX_{i,1} = \%NX_{6,1} * TNX_i \quad (10)$$

$$NX_{i,0} = TNX_i - NX_{i,1} \quad (11)$$

where  $i \geq 6$

Using the above general relation the forecast for students enrollment by class for each semester would be determined.

## 5. COMPUTER PROGRAM

A computer program has been developed considering the general equation no. (7). The program has been made interactive so that an experienced professional can run the program and edit the value of the default estimated parameters otherwise the program will run by the default values. In the appendix A, the student enrollment flow chart has been shown by class. In the appendix B, proposed program flow chart has been shown.

## 6. COMPUTATIONAL EXPERIENCE

For the purpose of illustration, let us forecast student enrollment in 971 in the KFUPM's sophomore (SO) class. Student enrollment in the FR, SO and JR classes for the last six terms has shown in Appendix C.

Using equation (1)

$$RX_{2,2} = X_{1,2} - X_{2,3} = 863 - 750 = 113$$

Similarly,  $RX_{3,2} = 93$ ,  $RX_{4,2} = 112$ ,  $RX_{5,2} = 190$ ,  $RX_{6,2} = 182$

Using the estimation equations (2)

$$\begin{aligned} 828 &= 964 A_2 + 113 B_2 \\ 942 &= 1086 A_2 + 93 B_2 \\ 1155 &= 1316 A_2 + 112 B_2 \\ 1294 &= 1552 A_2 + 190 B_2 \\ 1430 &= 1555 A_2 + 182 B_2 \end{aligned}$$

Using least squares method, the estimate of  $A_2 = 0.897$  and  $B_2 = -0.22$

Percentage of retained Sophomore students are %  $RX_{2,2} = 13$ , %  $RX_{3,2} = 11$ , %  $RX_{4,2} = 12$ , %  $RX_{5,2} = 16$ , %  $RX_{6,2} = 14$ . This result shows that the value of % $RX_{i,2}$  is reasonably stable over time. Therefore, for the purpose of forecasting we will assume the value  $RX_{i,2} = 14\% * X_{i-1,2}$  (see the section 4).

The forecast value of the SO class enrollment for the term 971 will be determined by the following way using equation (6):

$$\begin{aligned} X_{7,2} &= 0.897 * 1672 + (-0.22)(14\% * 1294) \\ &= 1460 \end{aligned}$$

In a like manner, the future enrollment for each classification level for each term can be determined. If the forecast value is not of satisfaction then a professional can rerun the computer program and can edit the value of  $RX_{i,2}$  to simulate the forecast. This situation is specially important in the case of a dynamic environment where new factors can change the usual trend.

## 7. CONCLUSION

The difference between forecasting and planning must be understood. An enrollment forecasting is a useful tool in planning but it must be recognized that the forecasting itself may generate planned actions which will affect future enrollments, thus, making the forecasting appear erroneous as the projected time period arrives. For example, a forecast indicating decreased enrollments might initiate administrative decisions and plans which could reverse the projected trend. Therefore, the forecast would ultimately appear to be incorrect, but without it, the changes could not have occurred. Finally, the forecasting of enrollments should be viewed as a continual process-not a project to be completed. The process must be continually rolling ahead while incorporating the most current information

regarding institutional student enrollment trends. After each term is underway, the recent enrollment for that term should be analyzed and corrected for use in the next forecasting as well as planning period.

## **ACKNOWLEDGEMENTS**

The authors would like to acknowledge the support provided by the King Fahd University of Petroleum and Minerals, Saudi Arabia. The authors are also grateful to an anonymous referee for comments that have improved the presentation of the paper.

## **REFERENCES**

- [1] Gardner, D. E., "Weight factor selection in double exponential smoothing enrollment forecasts." *Research In Higher Education*, Vol. 14, No. 1, 1981.
- [2] Lins, L. J., "Methodology of enrollment projections for colleges and universities." AACRAO Committee on Enrollment Projections, 1960
- [3] Mangelson, W.L., Norris, D. M., Poulton, N. L., and Seeley, J. A. "Projecting college and university enrollments: analyzing the past and focusing the future." Ann Arbor: Center for the Study of Higher Education, The University of Michigan, 1974.
- [4] Parker, G. G. "Enrollment Projections for Registrars and Admissions Officers." *College and University*, Volume 52, No. 2, Winter, 1977.
- [5] Parker, J. D., Gardner, D. E., and Matt, J. J. "Objective weight factor selection for double exponential smoothing enrollment forecasts." Paper presented at the annual conference of the California Association for Institutional Research, San Francisco, March 1979.
- [6] Russell, C.N., and Hoffman, B. B. "Three years into the future and beyond with a postsecondary demand and enrollment model." *Proceedings of the 16<sup>th</sup> annual forum of the Association for Institutional Research*, Los Angeles, May 1976, 109-111.
- [7] Suddarth, Betty M., "Enrollment Projections." *College and University*, Summer, 1975.
- [8] Wing, P. A., "Higher education enrollment forecasting: a manual for state level agencies." Boulder, Colo.: NCHEMS, 1974.
- [9] Winters, M.D., "An economic model for kindergarten enrollment forecasting" Dissertation, University of LA Verne, 1992.
- [10] Mcknight, J.H., "The Gradient Cohort-Survival Method: A Refinement of The Ratio Forecasting Method for Determining School District Enrollments" Dissertation, North Carolina State University, 1991.

Appendix A

**Student Enrollment by class**

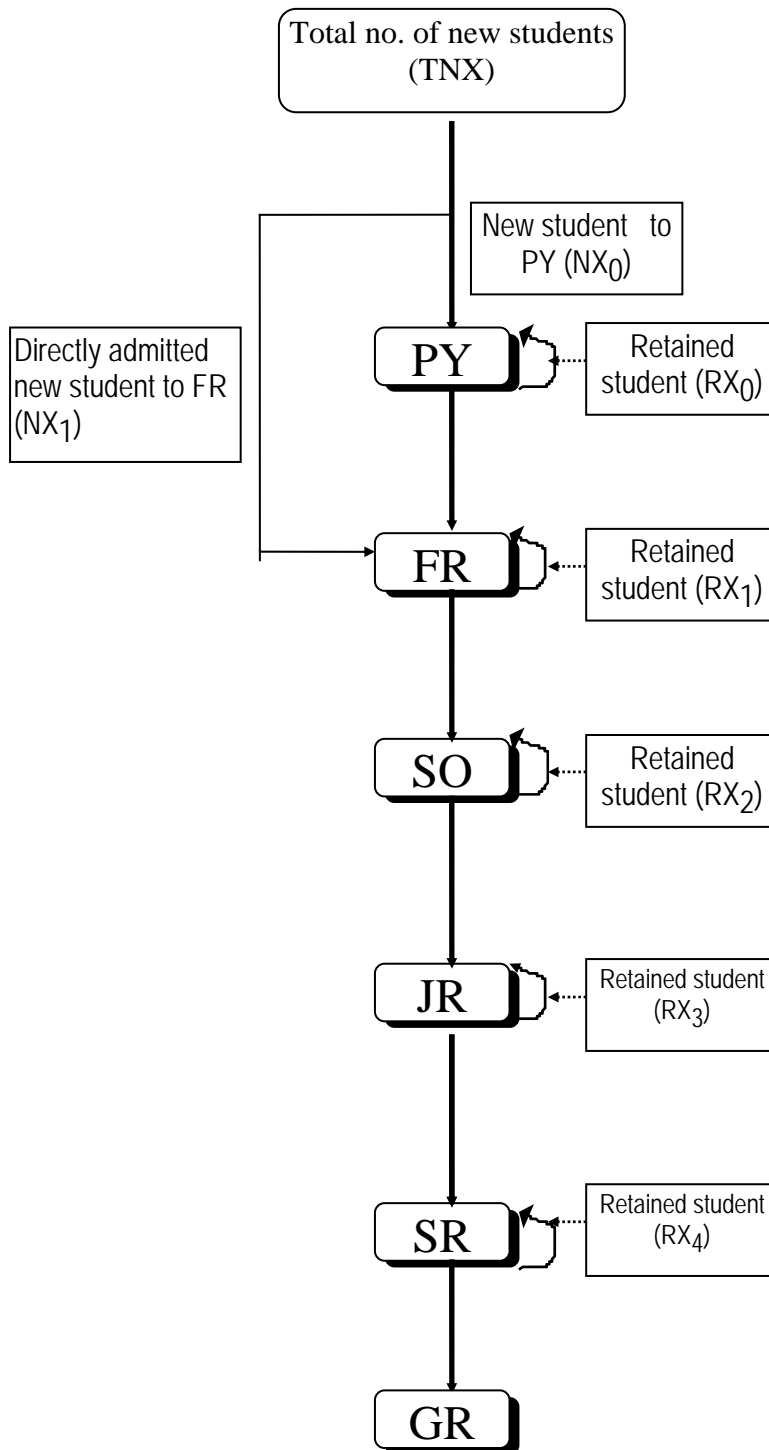

Appendix B  
**Program flow chart**

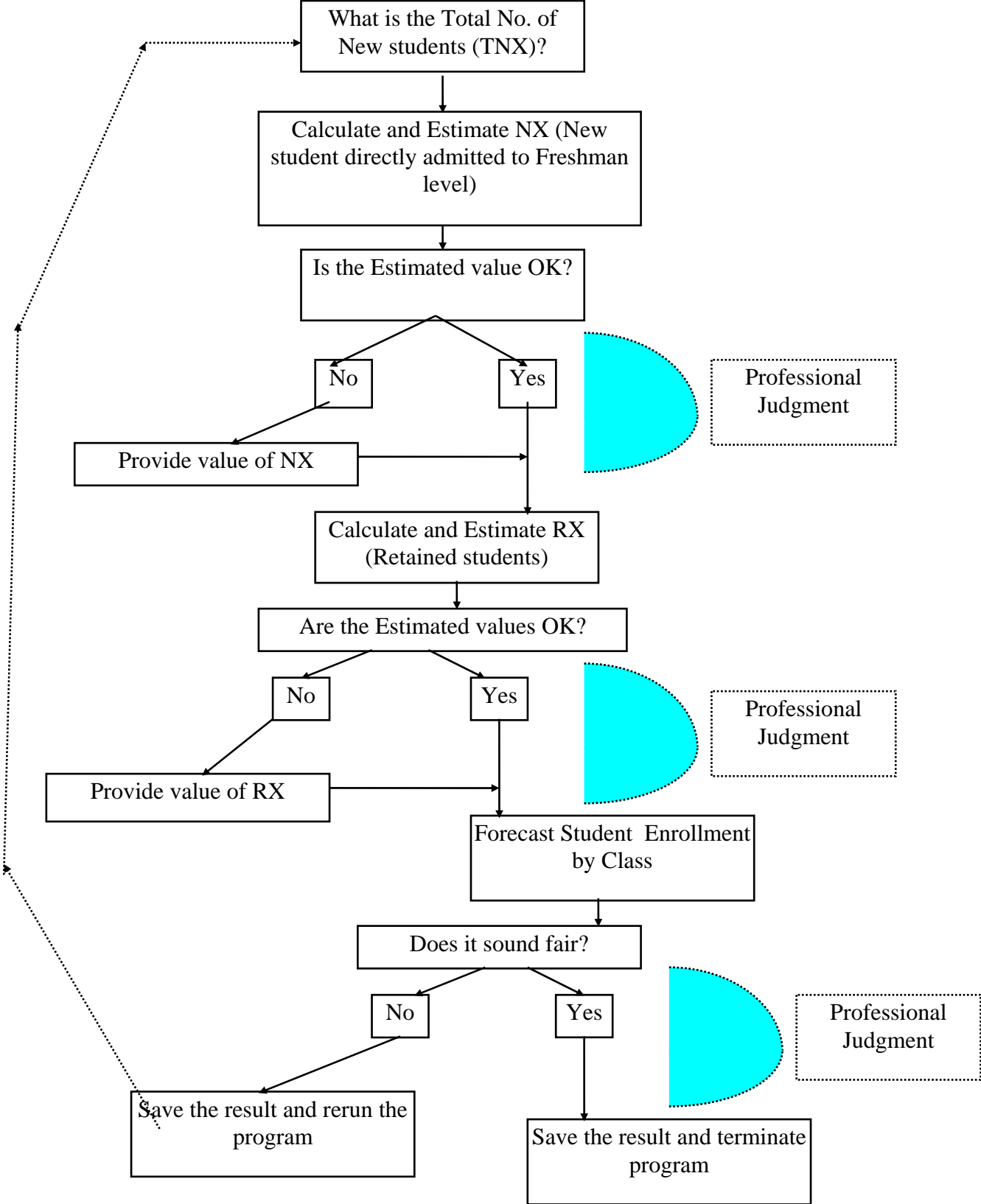

Appendix C



**KFUPM student enrollment in the freshman (FR), sophomore (SO) and junior (JR) classes**

<b>Term</b>	<b>FR</b>	<b>SO</b>	<b>JR</b>
<b>911</b>	964	863	661
<b>921</b>	1086	828	750
<b>931</b>	1316	942	735
<b>941</b>	1552	1155	830
<b>951</b>	1555	1294	965
<b>961</b>	1672	1430	1112