

noise; combustion engine;  
technical condition**Tomasz FIGLUS\***, Andrzej WILK, Kamil KRAJZEL

Department of Automotive Vehicle Construction, Faculty of Transport

Silesian University of Technology

8 Krasinskiego Street, 40-019 Katowice, Poland

\*Corresponding author. E-mail: [tomasz.figlus@polsl.pl](mailto:tomasz.figlus@polsl.pl)

## THE INFLUENCE OF DRIVE PARAMETERS AND TECHNICAL CONDITION ON THE VIBROACTIVITY OF DEVICES WITH SINGLE-CYLINDER INTERNAL COMBUSTION ENGINES

**Summary.** The study presents the important issue of the noise emission, generated by single-cylinder internal combustion engine constructions. This type of engine is used in drives of different types of machines and devices, including transport machines. In the study, the measurements and results analysis were conducted, which aim was to estimate the influence of the engine capacity, their power and the change of the technical condition on the generated noise. The researches of exemplary lawnmowers, equipped in this type of drive, showed the reduction of the sound level, together with the increase of the engines capacity and power decrease, and the increase of the noise (a few decibels) caused by the change of the technical condition during the operation.

## WPLYW PARAMETRÓW NAPĘDU I STANU TECHNICZNEGO NA WIBROAKTYWNOŚĆ URZĄDZEŃ Z JEDNOCYLINDROWYMI SILNIKAMI SPALINOWYMI

**Streszczenie.** Artykuł przedstawia ważny problem emisji hałasu generowanego przez urządzenia wyposażone w jednocylindrowe silniki spalinowe. Ten rodzaj silników stosowany jest do napędu różnego typu maszyn i urządzeń, w tym także maszyn transportowych. W artykule przeprowadzono pomiary i analizy wyników, których celem była ocena wpływu objętości skokowej silników spalinowych, ich mocy oraz zmiany stanu technicznego na poziom generowanego hałasu. Badania przykładowych kosiarek do koszenia trawy, wyposażonych w ten typ napędu, wykazały zmniejszanie poziomu dźwięku wraz ze wzrostem objętości skokowej silników i spadkiem ich mocy oraz kilkunastu-decybelowy wzrost hałasu spowodowany zmianą stanu technicznego podczas eksploatacji.

### 1. INTRODUCTION

There are many phenomena occurring in the environment, which may have a negative influence on the human body [1-6]. The use of machines and devices, additionally influences on the growth of danger of our health owing to the emission of vibration and noise, which occurs during work [5-11].

Single-cylinder combustion engines are the source of drive of different types of machines, including transport machines. However, their construction causes that during the operation they generate high level of vibration and noise which is treated as a threat in the environment and causes the decrease of comfort in the workplace. The internal combustion engines, as a source of drive,

however, deliver higher mobility but the noise level is much higher than with the use of electric engines [12-15].

As the example of very popular domestic device, which uses this type of drive we can take lawnmowers. The big number of lawnmowers and the extended time of their use make [10-11], that the vibration and noise are more dangerous for the environment and the operator.

In the study, the measures and the results analysis were conducted, in the framework of which the influence of the engines capacity, their power and the changes of the technical condition on the generated noise level were estimated. The sound level measures were conducted for the exemplary devices equipped in single-cylinder internal combustion engines, that is the lawnmowers. On the basis of the measures, the harmfulness of the noise level on the operator was estimated.

## 2. THE RANGE OF RESEARCH

The noise emission of examples manual lawnmowers with the internal combustion engines was investigated. These are, according to the definition enclosed in the directive 2000/14/WE of the European Parliament and in the Council of the European Union dated on 8<sup>th</sup> May 2000, machines having cutting element working on plain and using the ground level to specify the height of cutting regulated by wheels, air bag, etc.

For the research they used lawnmowers equipped with single-cylinder internal combustion engines, new and the worn ones, having inflexible cutting element. In table 1 the comparison of chosen lawnmowers was presented.

The estimation of their condition was carried out in the subjective way by the service as there is no possibility to read the time of their use. During the initial examination lawnmowers were grouped - according to their year of production, estimated number of hours of their use (from the last repair), estimated working hours in the season, current technical condition. The technical condition of new lawnmowers (without any trace of use) marked with value 0 (sign TC0), whereas the technical condition of the most used of lawnmower marked 4 (sign TC4).

Table 1

List of chosen lawnmowers

No	Make	Model	Year	Engine capacity [cm <sup>3</sup> ]	Engine Power [kW]	Rotation max [rpm]	Technical condition (TC)	Before / after repair
1	Husqvarna	M145SV	2007	158	2,1	2925	2	before
2	Husqvarna	LC48V	2010	190	2,4	2900	4	after
3	Partner	P53-675 DWA	2008	190	2,4	2950	3	after
4	Wolfgarten	2.42 B	2006	158	2,4	2800	4	after
5	Husqvarna	LB48V	2010	190	2,4	2900	1	before
6	Partner	P53-625 DE	2009	190	2,4	2950	2	after
7	Husqvarna	LC48V(2)	2010	190	2,4	2900	0	before
8	Power Performance	WYZ18	2010	158	2,4	2800	1	after
9	Husqvarna	JET50RP	2005	148	2,6	3200	3	after
10	NAC	C460	2009	140	2,7	3000	2	after
11	Husqvarna	R152SV	2008	161	2,8	2950	1	before
12	Elektrolux	553CME	2006	190	3,5	3050	3	after
13	COMAG	VSS53K60	2009	196	3,6	2900	2	before

The measurements of equivalent sound level ( $L_{Aeq}$ ) was carried out with the use of digital sound analyser SONOPAN DSA-50 with setting the filtration mode 1/3 octave and with A characteristics. During the measurements the weather condition was controlled, using to the weather station Terdens Moon BSP 1201.

The noise emission measurement was carried out in the following weather conditions:

- ambient temperature 14,2 - 16,5 °C,
- air-pressure 983 – 985,7 hPa,
- air humidity 62 – 87%,
- wind velocity 1 – 1,5 m/s.

With regard to comparatively narrow changes range of atmospheric conditions, which perturb the measurements, it was accepted that they were not important for the research.

In the research it was accepted that the microphone would be placed on a tripod on the level of 167cm above the ground that is on the level of the operator's ear (the man average height 178cm). The microphone was set in the distance of 0,4 m from the handle and was directed to the axis passing through the source of noise (internal combustion engine).

The research of the noise emission was carried out on the site, which was prepared in accordance with the diagram presented in figure 1.

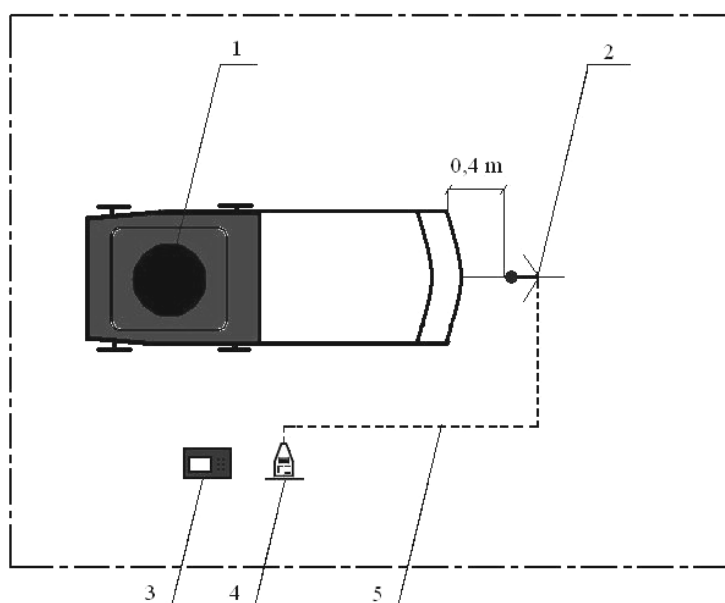

Fig. 1. The diagram of the measurement site: 1 – lawnmower with single-cylinder internal combustion engine, 2 – measurement microphone set on the tripod on the level of 167 cm above the ground, 3 – the weather station, 4 – the sound level meter, 5 – wire connecting the meter with the microphone

Rys. 1. Schemat stanowiska pomiarowego, gdzie: 1 – kosiarka z jednocylindrowym silnikiem spalinowym, 2 – mikrofon pomiarowy, zamocowany na statywie na wysokości 167 cm od podłoża, 3 – stacja pogodowa, 4 – miernik poziomu dźwięku, 5 – przewód łączący miernik z mikrofonem

The measure of each lawnmower was carried out 5 times. On the basis of obtained results the average value was calculated, concerning:

$$L_{Aeq} = 10 \cdot \log\left(\frac{1}{n} \sum_{k=1}^n 10^{0,1 \cdot L_k}\right)$$

$n$  – number of the elementary measurements in the measured set,  $L_k$  – the equivalent sound level during  $k$  of the measured period [dB(A)].

### 3. THE RESULTS OF RESEARCH AND THE ANALYSIS

In the first part of the research, the measure of the background surrounding was conducted in order to define the possibilities of its influence on the quality and quantity changes of the acoustic pressure, around the lawnmowers with single-cylinder internal combustion engine.

The example results of the measures of the equivalent background sound level  $L_{Aeq}$  and the temporary efficient value  $L_A$  of these measures are presented in table 2. Similarly, the results of the obtained measurements have not fundamental influence on the possibility of introducing errors during proper lawnmowers measurements.

Table 2  
The equivalent sound level and the efficient value level  
of the background surround

No of measurements	$L_{Aeq}$ [dB]	$L_A$ [dB]
1	44,2	42,5
2	42,4	42,8
3	43,2	45,6

The research results confirmed the essential influence of the engine extent use on the level of noise emission. It is particularly visible in case of Husqvarna lawnmowers LC48V and LC48V(2) which were produced in the same year (2010) by the same producer; the only difference was the extent of use. The engine of the first one was in a very good technical condition (the degree of use TC0) whereas in the second, the engine extent use was the highest among the examined lawnmowers (the degree – TC4). In spite of the fact that the engines of the lawnmowers have the same parameters, such as: power (2,4 kW), capacity (190 cm<sup>3</sup>), the clear differences in the equivalent sound level  $L_{Aeq}$  were stated for both lawnmowers, which is presented in fig. 2.

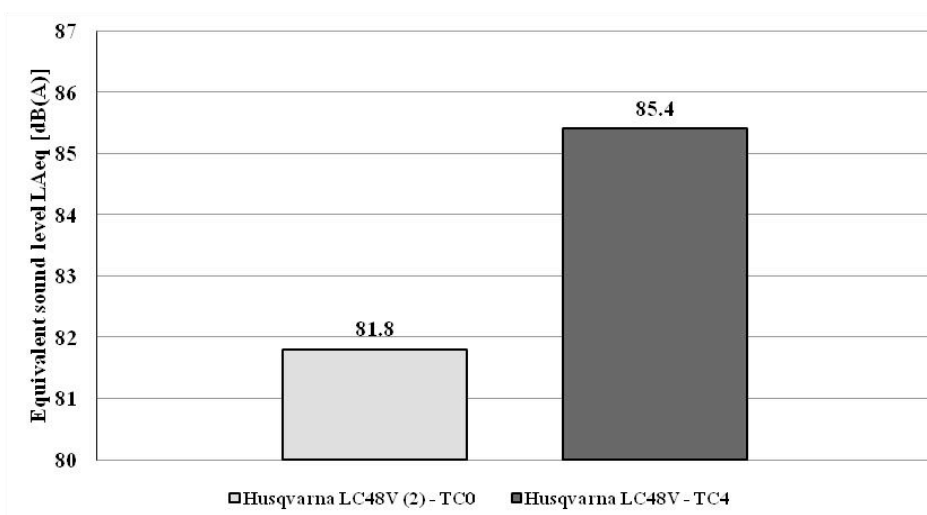

Fig. 2. The influence of the engine technical condition of Husqvarna lawnmowers LC48V(2) and LC48V on the equivalent sound level  $L_{Aeq}$

Rys. 2. Wpływ stanu technicznego silnika kosiarek Husqvarna LC48V (2) i Husqvarna LC48V na równoważny poziom dźwięku  $L_{Aeq}$

Moreover, the influence of the engine extent use was also confirmed by the analysis of equivalent sound level  $L_{Aeq}$  for the lawnmowers with the power of 2,4 kW and capacity – 190 cm<sup>3</sup>. The influence is presented in fig. 3.

Among the lawnmowers equipped in the engine – with the above mentioned parameters – only the deviation is evident in Husqvarna LB48V, for which the sound level  $L_{Aeq}$  is lower about 1dB than for Husqvarna LC48V(2), however, the extent use for the first one was estimated at TC1, and the second one at TC0. The reason of that may be the improvement by the producer, connected with reducing the noise level which was used in Husqvarna LB48V in relation to Husqvarna LC48V(2).

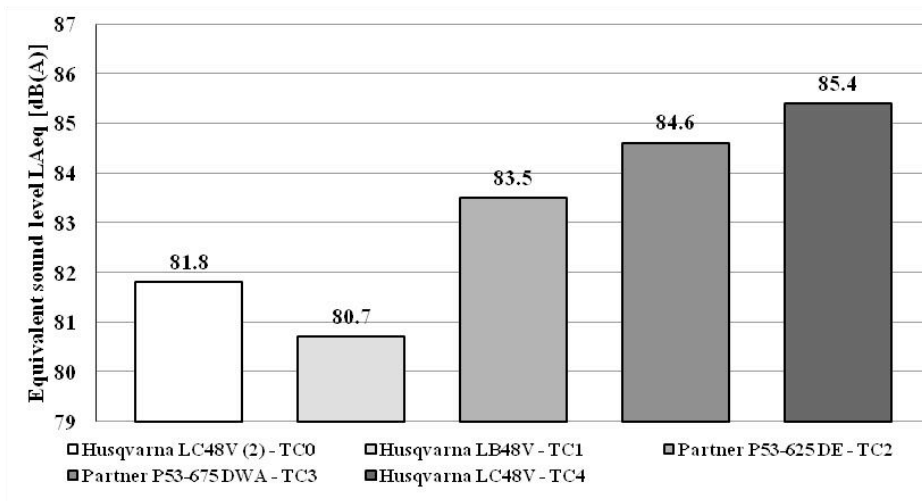

Fig. 3. The influence of the engine technical condition of the lawnmowers with the power – 2,4 kW and capacity – 190 cm<sup>3</sup> on the equivalent sound level  $L_{Aeq}$

Rys. 3. Wpływ stanu technicznego silnika kosiarek o mocy 2,4 kW i pojemności 190 cm<sup>3</sup> na równoważny poziom dźwięku  $L_{Aeq}$

The results of the measurement of the equivalent sound level for the Power Performance WYZ18 lawnmowers and Husqvarna LB48V also point at the influence of engine capacity with the same extent use (TC1) on the level of noise emission for the engines with the same power (2,4 kW). Shown in fig. 4.

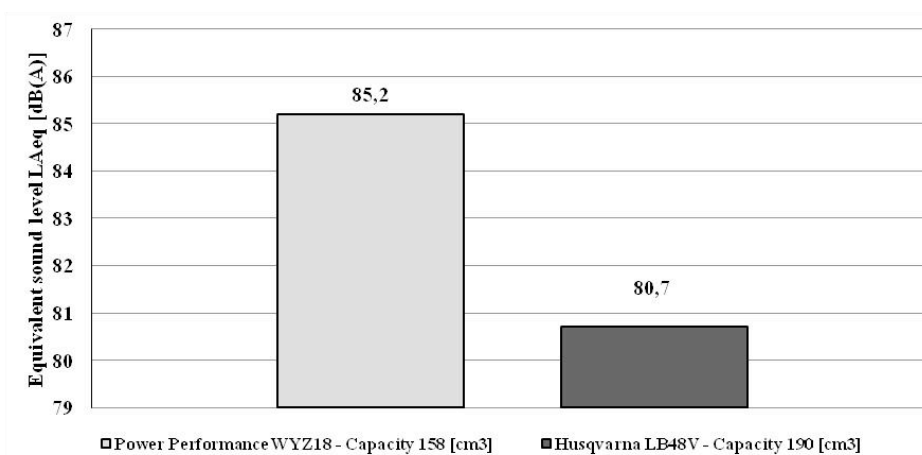

Fig. 4. The influence of the engine capacity with the power of 2,4 kW (the use degree 1) on the equivalent sound level  $L_{Aeq}$

Rys. 4. Wpływ pojemności silnika kosiarek o mocy 2,4 kW (stopień zużycia 1) na równoważny poziom dźwięku  $L_{Aeq}$

Comparing the equivalent sound level  $L_{Aeq}$  of the lawnmower Partner P53-625DE with higher use degree (TC2) with proper level  $L_{Aeq}$  of the lawnmower Power Performance WYZ18 (the extent use TC1) it is observed that there is an increase of equivalent sound level  $L_{Aeq}$  (1,7 dB) together with reducing the engine capacity with 190 cm<sup>3</sup> to 158 cm<sup>3</sup>.

The research results point at the increase of the equivalent sound level  $L_{Aeq}$  together with the increase of the engine power, in case when the lawnmowers are equipped in engines with the similar capacity. The influence for different engine capacities was stated (148 – 158 cm<sup>3</sup> and 190 – 196 cm<sup>3</sup>) which was presented in fig. 5 and 6.

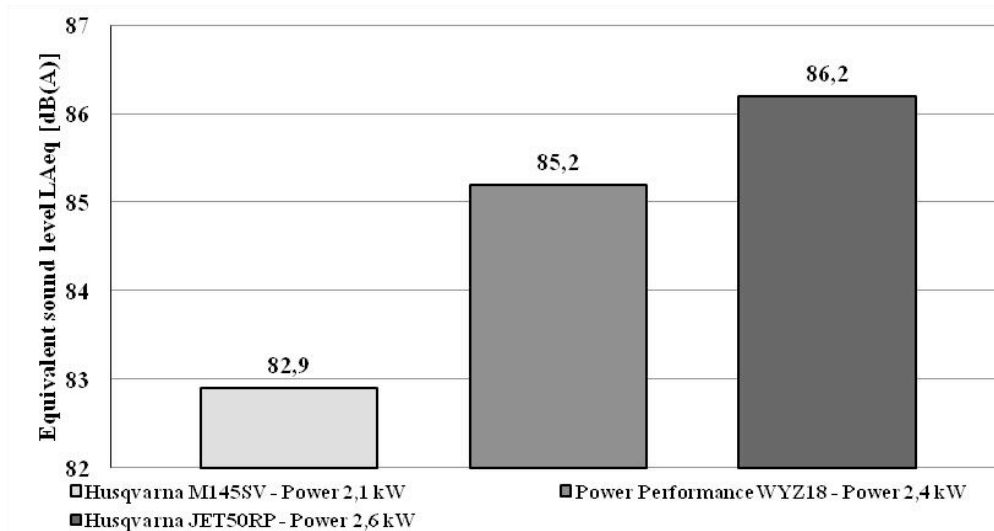

Fig. 5. The influence of engine power with the capacity of 148 – 158 cm<sup>3</sup> on the equivalent sound level  $L_{Aeq}$   
Rys. 5. Wpływ mocy silnika kosiarek o pojemności w zakresie 148 – 158 cm<sup>3</sup> na równoważny poziom dźwięku  $L_{Aeq}$

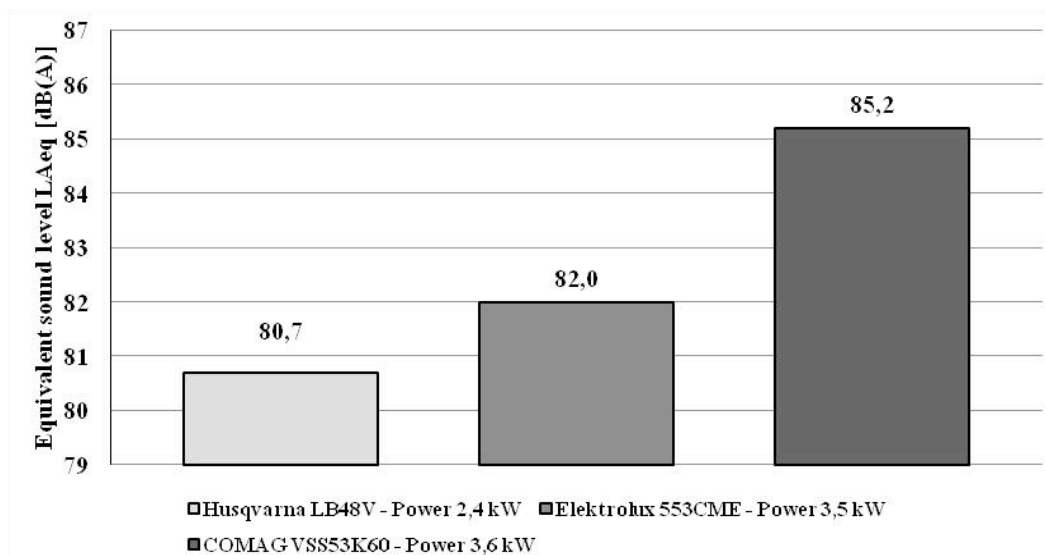

Fig. 6. The influence of engine power with the capacity of 190 – 198 cm<sup>3</sup> on the equivalent sound level  $L_{Aeq}$   
Rys. 6. Wpływ mocy silnika kosiarek o pojemności w zakresie 190 – 198 cm<sup>3</sup> na równoważny poziom dźwięku  $L_{Aeq}$

#### 4. CONCLUSION

1. The measures results confirmed the significant influence of the extent use of the same types of single-cylinder combustion engines on the level of noise emission.
2. The research results point at the influence of the equivalent sound level  $L_{Aeq}$  for the lawnmowers together with the power increase of their combustion engines for the lawnmowers equipped with engines with similar capacity.
3. The influence of the combustion engine capacity on the equivalent sound level was stated.
4. According to the directive 2003/10/WE of the European Parliament and the Council of the European Union dated on 6<sup>th</sup> February 2003, while using any of the examined lawnmowers by the specialised companies, which mow the lawn during 8 man-hour, there is necessity to use ear protectors during the exploitation.

#### Bibliography

1. Augustyńska, D. & Zawieski, W. *Ochrona przed hałasem i drganiami w środowisku pracy*. Warszawa: Centralny Instytut Ochrony Pracy. 1999. [In Polish]
2. Engel, Z.W. & Sadowski, J. (eds.) *Ochrona środowiska przed hałasem w Polsce w świetle przepisów europejskich*. Warszawa: Centralny Instytut Ochrony Pracy. 2005. [In Polish]
3. Makarewicz, R. *Dźwięki i Fale*. Poznań: Wydawnictwo Naukowe UAM. 2011. [In Polish]
4. Figlus, T. & Wilk, A. Comparison of the sound pressure measurement and the speed measurement of the gearbox vibrating surface. *Transport Problems*. 2012. Vol. 7. No. 1. P. 37-42.
5. Wilk, A. & Madej, H. & Figlus, T. *Analysis of the possibility to reduce vibroactivity of the gearbox housing*. Eksploatacja i Niezawodność. 2011. Vol. 50. No. 2. P. 42-49.
6. Burdzik, R. Monitoring system of vibration propagation in vehicles and method of analysing vibration modes. In: Mikulski, J. (ed.) *TST 2012, CCIS 329*, Heidelberg: Springer. 2012. P. 406-413.
7. Dudarewicz, A. & Toppila, E. & Pawlaczyk-Łuszczynska, M. & Śliwiska-Kowalska M. The influence of selected risk factors on the hearing threshold level of noise exposed employees. *Arch. Acoust.* 2010. Vol. 35. No. 3. P. 371-382.
8. Starck, J. & Toppila, E. & Pyykkö, I. Hearing protectors. In: Luxon, L. & Linda, M. & Prasher, D. (eds.) *Noise and Its Effects*. London: John Wiley & Sons Ltd. 2007. P. 667-680.
9. Daniell, W.E. & Stover, B.D. & Takaro, T.K. Comparison of criteria for significant threshold shift in workplace hearing conservation programs. *J. Occup. Environ. Med.* 2003. Vol. 45. No. 3. P. 295-304.
10. Leinert, J. & Griffin, R. & Blackburn, J. & McGwin, G.Jr. The epidemiology of lawn trimmer injuries in the United States: 2000-2009. *Journal of Safety Research*. 2012. Vol. 43. P. 137-139.
11. Nguyen, A. & Raymond, S. & Morgan, V. & et al. Lawn mower injuries in children: A 30-year experience. *ANZ Journal of Surgery*. 2008. Vol. 78. No. 9. P. 759-763.
12. Ying Hao, K. & Xin Mei, L. & Mohd Ripin, Z. Tuned vibration absorber for suppression of hand-arm vibration in electric grass trimmer. *International Journal of Industrial Ergonomics*. 2011. Vol. 41. P. 494-508.
13. Ying Hao, K. & Lu Ean, O. & Mohd Ripin, Z. *The design and development of suspended handles for reducing hand-arm vibration in petrol driven grass trimmer*. International Journal of Industrial Ergonomics. 2011. Vol. 41. P. 459-470.
14. Weiss-Cohen, M. & Sirotin, I. & Rave, E. Lawn mowing system for known areas. In: *2008 International Conference on Computational Intelligence for Modelling Control and Automation, CIMCA 2008*. No. 5172683. P. 539-544.
15. Ahn, Y.K. & Song, J.D. & Bo-Suk, Y. Optimal design of engine mount using an artificial life algorithm. *Journal of Sound and Vibration*. 2003. Vol. 261. P. 309-328.