



Design and realization of a multisamples rotating high cycle fatigue machine

Domenico Gentile

DICeM – University of Cassino – via G. Di Biasio, 43 – 03043 Cassino, Italy

Massimo Martorelli

DiME – University of Naples Federico II – School of Engineering, P.le V. Tecchio 80 - 80125 Naples, Italy

massimo.martorelli@unina.it

ABSTRACT. In this work the design and the technical characteristic of a Moore rotating bending machine are presented. The machine has been realized at the University of Cassino in order to run tests on multiple specimens at different temperature. The user can choose independently the load and the temperature for each specimen. The machine has been designed to produce in short time a several numbers of data of materials fatigue strength at low costs. The machine is in assembling step at the Laboratory of Industrial Design of the University of Cassino.

KEYWORDS. Fatigue; Wholer; Test machine; Product design process.

INTRODUCTION

Fatigue research has been conducted on a multitude of testing machine ranging from rotating bending loading, axial loading, repeating bending loading and torsional loading. The design varies according to the nature and combination of load and components, to the type of fatigue test (high cycle, low cycle, thermal fatigue), to the scale (small specimens, full scale components).

In this work the design of a low-cost and reliable rotating bending fatigue testing machine that meets the following criteria has been issued:

1. Minimum mass so that high cycle fatigue testing can be done on this machine.
2. Constant bending moment on specimen throughout testing.
3. Up to 5 samples tested in the same time.
4. Commercially available components adopted where possible.
5. Designs, material selection, machinery specifications for unavailable components.
6. Possibility to update easily the machine.
7. Possibility to run tests at different temperature

The idea is to realize a low cost machine that should be extremely adaptable.

Rotating machine configuration is one of the simplest and efficient in order to test a sample by a time variable load under constant amplitude, Fig. 1.

First machine has been design by Wöhler [1]. The simplest configuration has been proposed from Moore and Krouse [2] that reached speed of the order of 30.000 rpm. The machine, using four point bending system, allows to load the sample with a constant stress on the full measure zone. Leher [3] and next Moore developed solutions in this way. This

configuration can be adapted easily in order to test more samples together. Prot [4] developed a machine able to test up to 30 samples in the same time.

Basically a simple bending moment is applied to a specimen gripped at both ends to a rotating shafts, Fig. 1. This configuration has been modified every time following the needed.

Recently Irfan et al. [5], has been realized a rotating bending fatigue machine able to test at the same time up to 16 laminated composite samples. New machines, D. Brandolisio et al. [6], realized recently show that design process requires a specific analysis of the new mechanical components available commercially. A previous analysis on the materials used to realize the shaft has been conducted following a methodology proposed from Bonora et al. [7-10].

Today the use of parametric CAD models plays an essential role in the product design process, mainly, but not only [11], in the industrial field [12, 13].

Having the parametric CAD model of the product, it is possible to make any virtual simulations on it, also in terms of fatigue lifetime [14].

Although the fatigue virtual simulations are very useful, the experimental tests are fundamental to validate the results.

In the paper the analysis have been carried out using CAD parametric models and electronic calculus sheets formatted following the project desiderata.

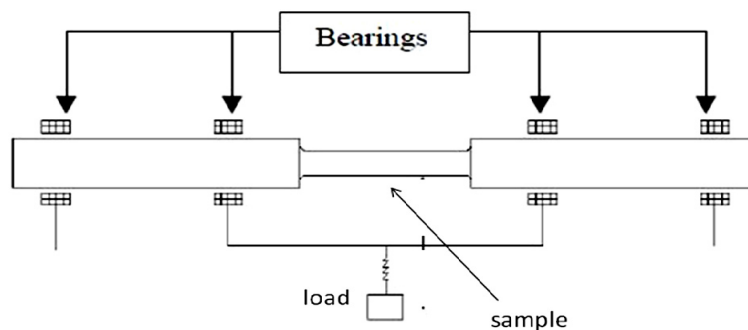

Figure 1: basic design of a R.R. Moore fatigue testing machine.

GEOMETRY AND COMPONENTS DEFINITION

In order to take into account all the specifications required has been realized an electronic work sheet containing all the calculations and all the characteristic of the components adopted for the design. In this way every time there was a needed of a change of component in order to, for example, minimize cost, all the analysis come out automatically. In order to calculate the bending moment and rotation, the bearing life, the spring requirements and the chassis design, has been used the classic mechanical laws such as:

$$\frac{16}{\pi d^3} (4M^2 + 3T^2)^{1/3} \leq \frac{S_y}{n} \quad (1)$$

where M is the bending moment, T is the torsional moment, S_y is the yield stress of the material, n is the safety factor and d is the minimum diameter. Or the more useful following equation that allows to estimate an initial shaft size early in the design process:

$$d = \left[\frac{32n}{\pi} \sqrt{\left(\frac{k_f M}{S_e} \right)^2 + \frac{3}{4} \left(\frac{T}{S_{yt}} \right)^2} \right]^{1/3} \quad (2)$$

where S_e is the material ultimate endurance limit, S_{yt} is the yield stress to torsion and k_f is the stress intensity factor under cyclic load. This equation gives the minimum diameter shaft that will result in infinite fatigue life, and appears in the ANSI Standard.

First question was to ensure the constant bending load. This specification can be met if the specimen grips can avoid inflection and rotation of the specimen. For this reason commercial grips have been adopted These grips are produced



from CEPI (commercial code 32, patented) according to DIN 6499 class 2 standards in order to grant seal and centering and that was also able to allow different specimen's geometry, Fig. 2.

Next step has been to design the shafts. Analyses have been conducted following the classical mechanical laws, realizing parametric CAD models that allow to change one or more dimensions.

Electronic sheets have been implemented in order to take into account the mechanical materials parameters and all the costs: commercial part, machine working of components, etc.

In Tab. 1 is reported a worksheet sample of stress analysis; in Tab. 2 a sample of cost analysis.

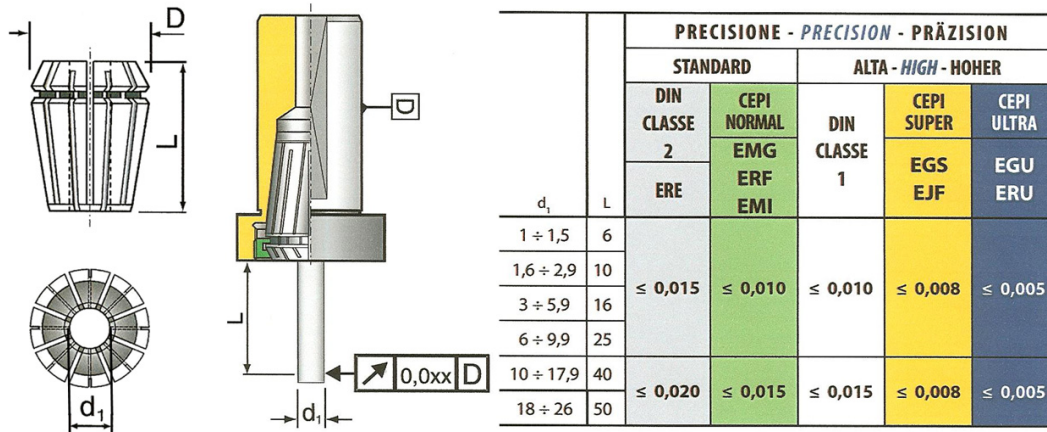

Figure 2: Grips: a) geometry; b) dimension as DIN6499 standard (all the measure are in millimeter). CEPI Catalog.

Material data				
commercial name	Elastic Modulus E [MPa]	failure stress [MPa]	yield stress [MPa]	endurance limit [MPa]
material 1	210000	400	250	180
material 2	210000	600	480	300
geometrical data				
diameter 1	25 mm	Von Mises stress		
diameter 2	28 mm	section 1/2		296 MPa
diameter 3	30 mm	section 2/3		195 MPa
diameter 4	32 mm	section 3/4		173 MPa
radius 2/1	2 mm			
radius 3/2	2 mm			
radius 4/3	2 mm			
d2/d1	1,12			
d3/d2	1.07			
d4/d3	1.07			
Load				
Load	1800 N	stress concentration factors	Bending	Torsion
distance	100 mm	Kt (2/1)	1.80	1.60
Bending	180000 Nmm	Kt (3/2)	1.70	1.45
Torsion	400000 Nmm	Kt (4/3)	1.82	1.61

Table 1: Example of the work sheet implemented for calculus.



COMPONENT	UNIT. COST (€)	TOTAL NUMBER	TOTAL AMOUNT (€, NO TAX)	TOTAL AMOUNT (€, 21% VAT)
carriage 4 linear recirculating ball bearing units	31.56	20	631.20	763.75
Linear guidance systems with recirculating ball bearing units	24.48	10	244.80	296.21
self-lubricating kit	27.91	20	558.24	675.47
cover 15	0.16	50	8.00	9.68
ring nut	14.69	10	146.88	177.72
belt 340	4.80	1	4.80	5.81
belt 525	5.70	1	5.70	6.90
belt 400	5.10	4	20.40	24.68
pulley 30	3.90	10	39,00	47.19
timing-belt pulley	4.80	2	9.60	11.62
bearing	3.30	2	6.60	7.99
choke ring	1.50	20	30.00	36.30
bearing 3203	17.79	20	355.80	430.52
bearing 22206	39.81	20	796.20	963.40
choke ring A25	1.20	5	6.00	7.26
encoder+fan	1050.00	1	1050.00	1270.50
LSMV 80	222.30	1	222.30	268.98
sub-total			4135.52	5003.98
	MIN (€)	MAX (€)	MIN + tax (€)	MAX + tax (€)
machinery	10000.00	€ 10000.00	€ 12000.00	€ 12100.00
software	3000.00	€ 5000.00	€ 3600.00	€ 6050.00
			€ 15600.00	€ 18876.00
total amount			€ 20603.98	€ 23879.98

Table 2: Example of the work sheet implemented for cost analysis.

This procedure allowed to have a clear process of realization: clear components, clear machinery work, clear costs, clear assembling and verification.

Components that were not possible or convenient to have commercially, have been designed and realized very accurately in order to ensure constant bending at high fatigue cycles.

One of these parts is the spindle body with the related shafts and supports. Part of spindle is reported on Fig. 3.

Also shafts have been realized in house. Following classical mechanical formulae in order to verify strength and stiffness the shaft reported in Fig. 4 has been defined.

Other fundamental components are the bearings. Among the solutions available bearings by SKF have been used. From SKF catalogue have been selected the following: spherical roller bearings SKF 22206 E (CCW33), angular contact ball bearings, double row SKF 3203 ATN9 in order to support spindle's shaft, and deep groove ball bearings, single row SKF 6004-2RSH as support of connectors between engine and pulleys.

In order to have a very useful machine in different conditions, as for example fatigue tests at high temperature, a system with a single engine has been preferred to realize, five different load cells have been used, one for each sample. This allowed to realize a modular machine able to work for one or "n" samples depending of the mounted spindles.

Concerning the fatigue tests a different temperatures, this machine is able to test each specimen at different temperature in a single test.



In Fig. 5 the spindles group has been reported. All the spindles are connected at the same asynchronous engine capable to reach a 4500 rpm speed.
Load cells are connected under the spindles plane, (not reported in the figure), counterbalanced by special gas springs in order to grant better applying load method.
Best operating conditions for this machine are: 5 specimens and 3000 rpm engine's speed.

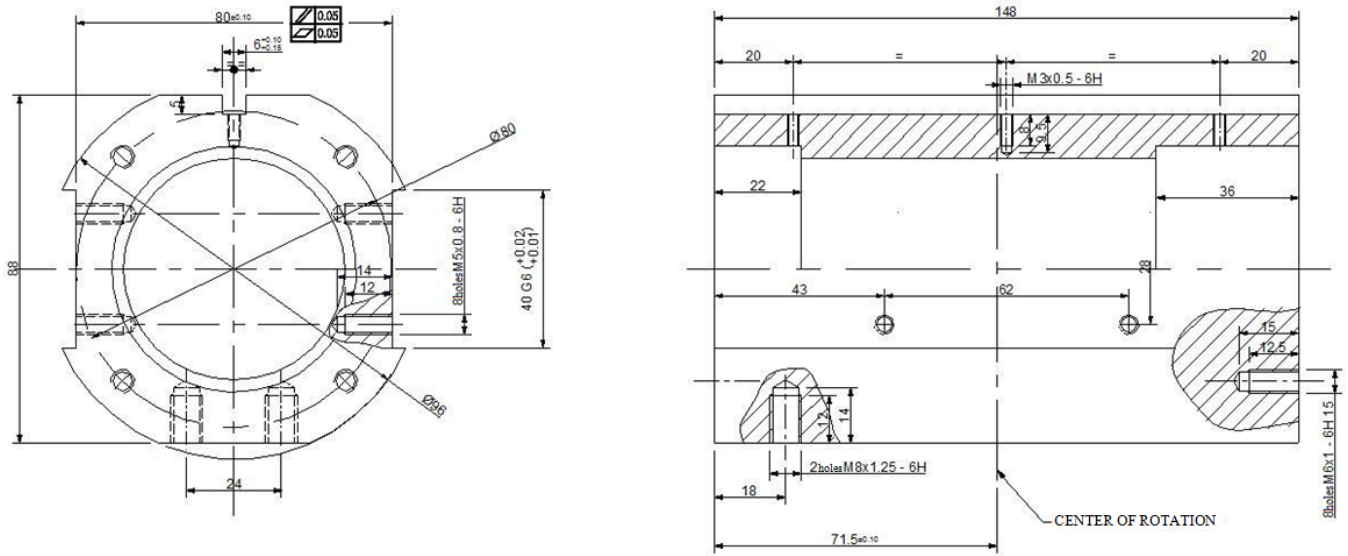

Figure 3: Spindle body.

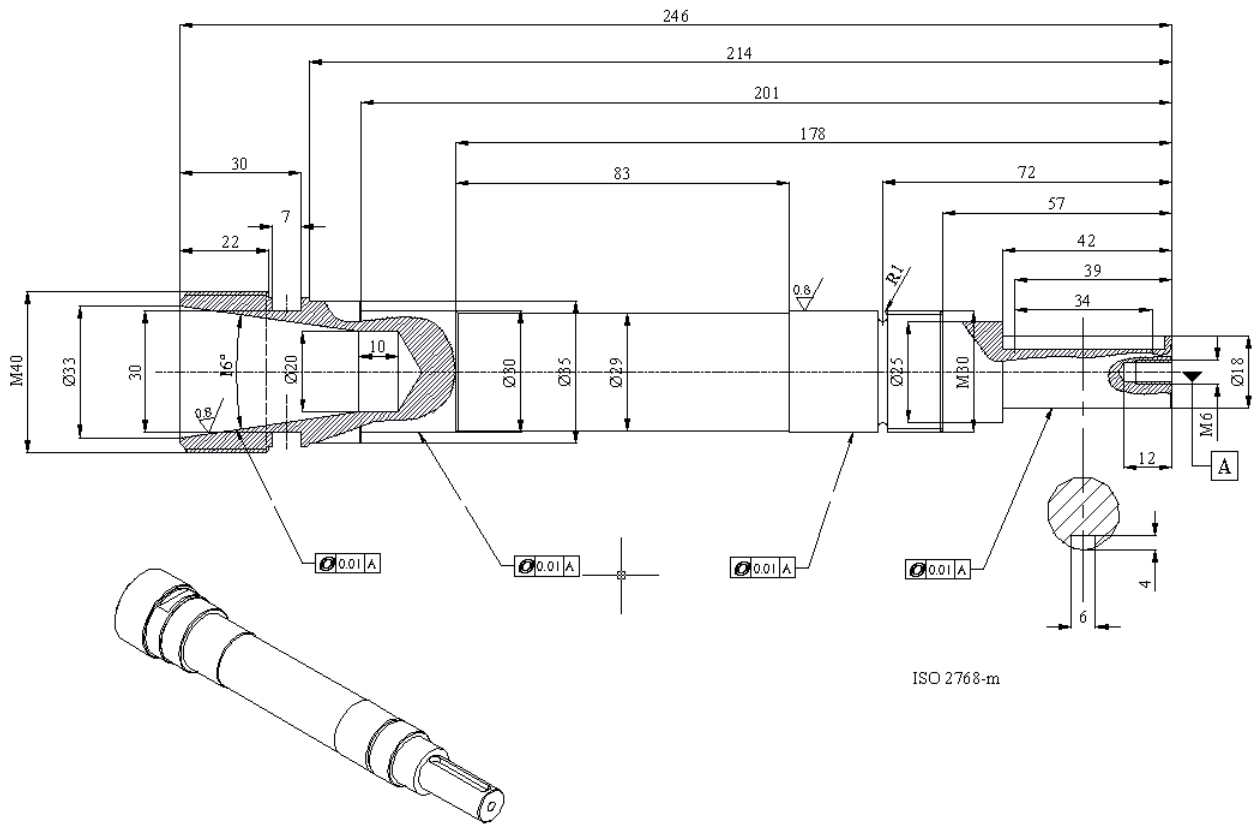

Figure 4: Driven shaft.

Gas spring has been selected from commercial catalogue by ACE: maximum extension range 100 mm, maximum load 1440 N, Fig. 6.

Power transmission has been realized by a system of toothed belts and pulleys, Fig. 7.

Belts are made in “polychloroprene” with steel core. Pulleys has type HDT (European standards) with 5 mm pitch for belts 15 mm width.

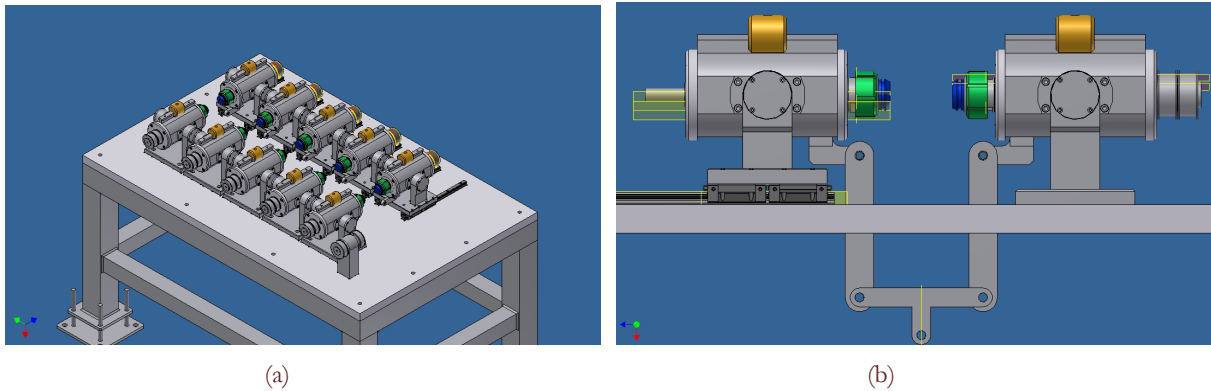

Figure 5: Spindles group: a) total view; b) load system details.

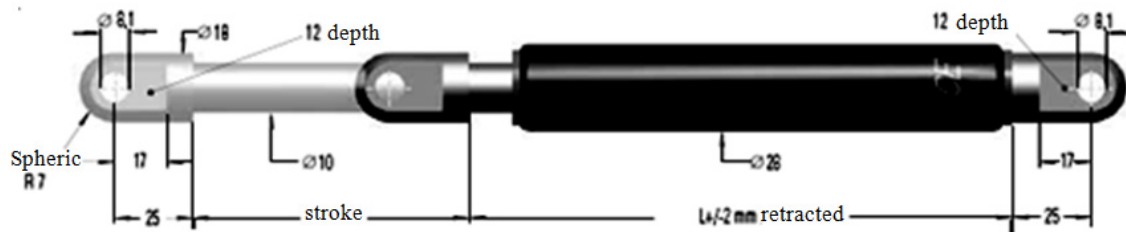

Figure 6: Gas spring. (ACE commercial catalog).



Figure 7: Belts and Pulleys.

Most of the commercial components, like load cells or springs has been assembled in order to allow their substitution for eventual upgrades.

Spindles are mounted on rails to allow different sample's length.

Also the control system has been designed in order to allow easy upgrade: for each sample there is a cycles counter and an encoder connected with a computer that allows to control separately each related load cell by a dedicated software.

Control system provides the possibility to send external trigger at defined numbers of cycles in order to allow measure by video camera or other kind of instruments.



A schema of a possible configuration has been reported in Fig. 8.

As a sample break, cycles counting will stop. The related shaft will stop leaving the others shafts to run without changing load or speed. Gas spring and related connectors will avoid load cell drop and will allow his repositioning to a virtual zero. The machine is equipped with a spindle's safety blocking system by a micrometer screw that prevents shaft bending up to defined limits.

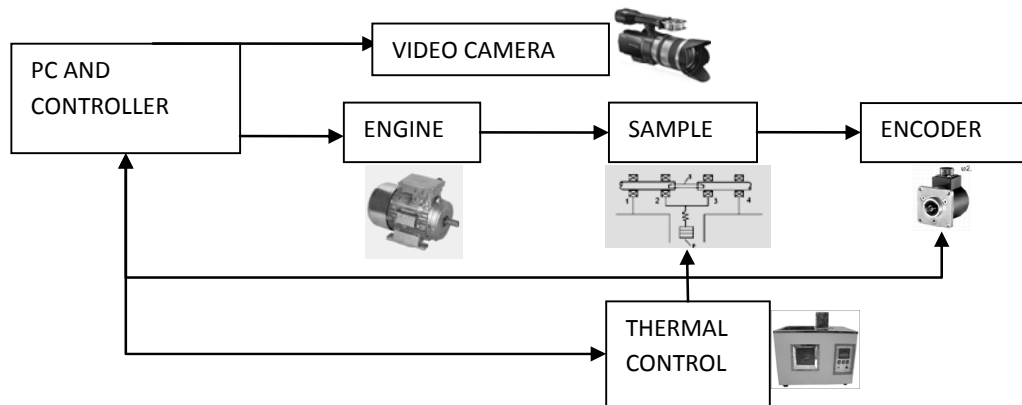

Figure 8: Functional Scheme.

Complete system is mounted on a single steel chassis, which is possible to fix on the floor by screws and dumping interfaces.

In order to run tests at different temperature a system using oil is in the process design at the moment (a procedure to obtain a patent has been started). The idea is that different temperature can be applied to specimens by oil in different heaters, one for each specimen.

CONCLUSION

In this work the executive project has been presented in order to realize a rotating fatigue bending machine. The aim was to develop a machine at low costs and capable to test many specimens at the same time and eventually at different temperature. At the present the machine is being tested at the Lab. of Industrial Design of the University of Cassino in collaboration with CREA (Center of Reverse Engineering Applications) Lab. of the University of Naples Federico II for CAD/FEM simulations. Cost and construction time are less than similar commercial machine that are able to test only one specimen. The machine can be used changing many parameter's test and is already predisposed to run test at high temperature. This part will be completed after the preliminary tests. The possibility to combine different loads and temperature with a single test controlling independently the load cells and the warming room with a single asynchronous engine is very interesting.

REFERENCES

- [1] Wöhler, Z. Baaw. 8 (1858-1870) 641.
- [2] H. F. Moore, G. N. Krouse University of Illinois, Engng. Exp. Sta. Circ., 23 (1934) 7.
- [3] F. Lehr Die Abkürzungsverfahren zur Ermittlung der Schwingungsfestigkeit von Materialien, Dr. - Ing. Diss. TH., Stuttgart (1925)
- [4] F. M. Prot, Rev. Métall., 34 (1937) 440.
- [5] A. Irfan, S. Raif, O. Güven, Materials and Design, 29 (2008) 397.
- [6] D. Brandolisio, G. Poelman, G. De Corte, J. Symynck, M. Juwet, F. De Bal, FATIMAT project, <http://mechanics.kahosl.be/fatimat/>, (2009)
- [7] N. Bonora, A. Ruggiero, D. Gentile, S. De Meo, Strain, 47 (2011) 241, doi: 10.1111/j.1475-1305.2009.00678.x 253
- [8] N. Bonora, A. Ruggiero, L. Esposito, D. Gentile, Int. J. of Plasticity, 22(11) (2006) 2146.
- [9] N. Bonora, A. Ruggiero, Int. J. of Solids and Structures, 42(5-6) (2005) 1401.



- [10] N. Bonora, A. Ruggiero, *Composites Science and Technology*, 66 (2) (2006) 323.
- [11] P. Ausiello, P. Franciosa, M. Martorelli, D. C. Watts, *Dental Materials*, 28(8) (2012) 919.
- [12] S. Gerbino, M. Martorelli, D. Oliviero, In: *Proc. of International Design Conference, Design 2006, Dubrovnik, May 15-18, ISBN 953-6313-82-0 (2006)*
- [13] M. Martorelli, D. Oliviero, *Journal of Mechanics Engineering and Automation*, 2(4) (2012) 213.
- [14] P. Ausiello, P. Franciosa, M. Martorelli, D. C. Watts, *Dental Materials*, 27(5) (2011) 423.