



ANALELE UNIVERSITĂȚII  
“EFTIMIE MURGU” REȘIȚA  
ANUL XII, NR. 1, 2005, ISSN 1453-7394

---

Răduca Mihaela, Răduca Eugen, Tătucu Iancu

## Hydrogenerator Stator Rehabilitation Methods

*In this paper are presented the hydrogenerator stator rehabilitation methods, stator forming the followings subassemblies: frame, stator core, stator winding, terminals and terminals box. The stator rehabilitation are execute after the guaranteed time established by supplier firms or if in function time was appear different defects, defects that can out in function of hydrogenerator. Stator rehabilitation can be make through changing stator subassemblies parts or through by replacement existent subassemblies with new subassemblies compatible with hydrogenerator.*

### 1. Introduction

The stator rehabilitation are execute after the guaranteed time established by supplier firms or if in function time was appear different defects, defects that can out in function of hydrogenerator.

The components of stator hydrogenerator are:

- Frame
- Stator core
- Stator winding
- Terminals and terminals box

The main defects that will be appear in function of hydrogenerator stator are the followings:

- Deformation of stator frame
- Deformation and buckling of stator core, because the core can not to dilate
- Putting at mass of stator winding
- Friction of rotor in stator
- Slot wedges may be burn
- Stator packing wedges may be fall down
- Burning of terminals insulating

This defects are major defects which going out the damage of hydrogenerator.

For this defects are removed, to impose the stator rehabilitation.

In figure 1 is presented a completely assembled stator sector.

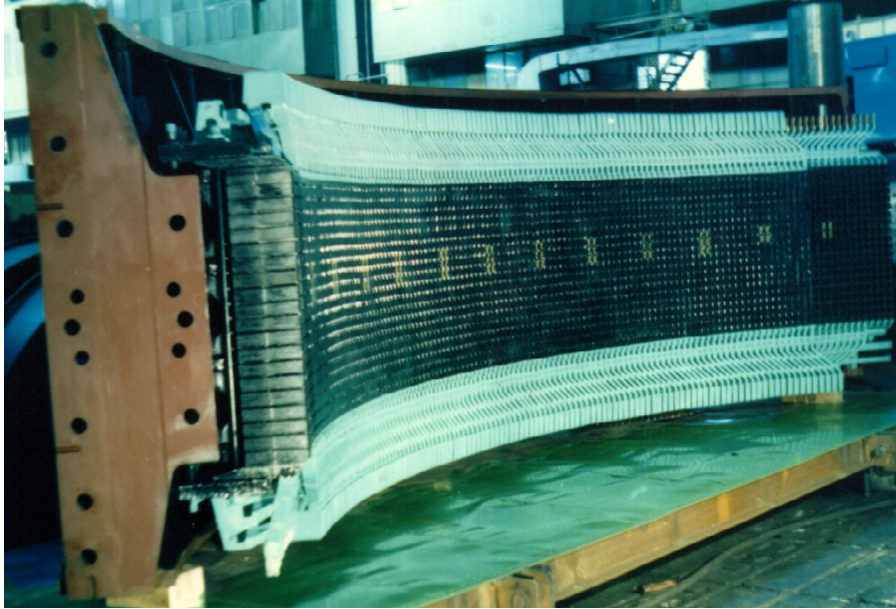

**Figure 1.** Completely assembled stator sector

Stator rehabilitation can be made through changing stator subassemblies parts or through by replacement existent subassemblies with new subassemblies compatible with hydrogenerator.

## **2. Contents of paper**

### 2.1. Frame rehabilitation

Usefully, the frame will be rehabilitation and not execute as well as a new component.

After the dismantling of winding and stator core, the frame will be centering on the foundation with help a centering device.

The fixing wedges of stator core will be welding of frame racks. The centering this will be making by help of centering column.

The place with this wedges was replaced will be coated.

If the frame is new subassemblies, this is redesigned with a high rigidity, but this must be re-correlated by dimensions of stator core.

### 2.2. Stator core rehabilitation

The stator core may be rehabilitation or may be completely new component, in function of defects appear. In figure 2 is show the stator core.

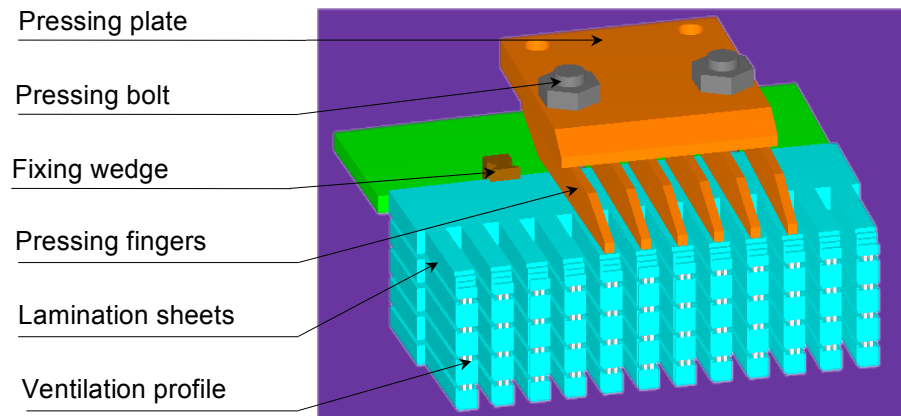

**Figure 2.** Stator core

The rehabilitation of stator core consist in the followings:

- Checking of stator core at inner
- Straighten of lamination sheet of damage zone
- Elimination of lamination sheet contact in cleaning zones through treating with acid, neutralization, washing, impregnation.
- Remaking of protection coated.

If the stator core is very damage, this is completely new. This operation will be make the followings:

- Changing the actual lamination sheet with a high lamination sheet, with low losses
- Stator core pressing with pressing plate. This plate is with pressing fingers by nonmagnetic material, being pressing with pressing bolts, with elastic washers, which assure kept out in time a residual pressure of core.
- Packing in ring, out of separation planes, on wedges with double dovetails, which enable radial dilatation of core in frame
- Number of stator core packing wedges will be optimally choose thus the critical sollicitation values in stator core will be minimum.
- Pressing fingers will be optimally designed, point of view mechanical and for to reduce a losses in these
- Optimal dimensioning point of view of ratio between height elementary pack and a ventilation duct
- Radial ventilation ducts, making with "I" profile by inox

### 2.3. Stator winding rehabilitation

The stator winding, usually, will be rehabilitation, with keeping actual winding bars (stator cooper).

In figure 3 is show the stator winding.

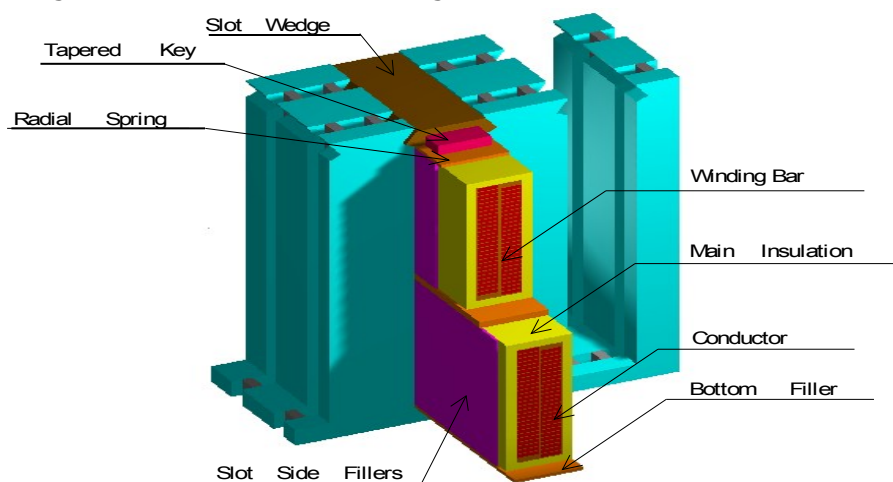

**Figure 3.** Stator winding

All pieces and insulations used the stator winding will be make a new materials, based by advanced technologies, thus:

- New insulating system, performed, making with ISOVOLTA materials, with insulating bars, conducting and semi conducting
- Slot slide fillers are with conductor sticlotextolite
- Radial filler are with wave sticlotextolite by Ripple Spring type
- Closing wedges are fibroplast or sticlotextolite type
- Distance pieces and consolidation frontal heads are with a advanced geometry point of view of rigidity and of ventilation air circulation
- Frontal head cover are fibroplast
- Wedge fixing system for migration braking in pack length.

After the insulation bars changing, they will be test by a special program of tests and checking by quality program, thus the electric field inside the insulation have optimally values.

In figure 4 is show the distribution of electric field inside the insulation.

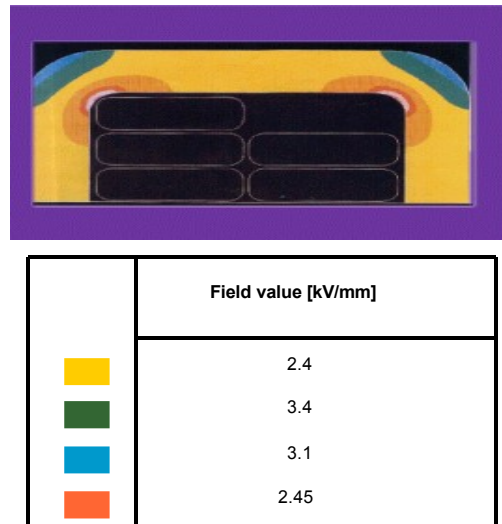

**Figure 4.** Distribution of electric field inside the insulation

After the tests all the bars, these will be classified, marked and distribution in winding, after the followings: winding bars will be classified on three quality class, in function of test results and will be distributed in stator winding in function of they quality.

The distribution on each phase of bars will be make beginning from null at terminals in quality function.

In the slots beginning from null are low quality bars and in the slots from principal terminal will be high quality bars. In the slots where are phase changing will be good quality bars.

#### 2.4. Terminals and terminals box rehabilitation

The rehabilitation of terminals supposes the followings:

- Dismantling the connections
- Restoration of defect zones
- Insulation of rotor connections with a new materials
- Replacement of consolidation elements

### 3. Conclusion

The guaranteed period for a hydrogenerator is maximum 20 years. In this time, because of different defects, defects that can out in function of hydrogenerator, the stator hydrogenerator must be rehabilitation. The stator rehabilitation has a lower cost and have necessary a short time of work.

### References

- [1]\*\*\*, IEC Standards Collection Electrical Machine.
- [2]\*\*\*, IEEE Collections for Electrical Machines.
- [3]R. Radulet, M. Opaschi, "Proiectarea hidrogeneratoarelor si a motoarelor sincrone", Editura Tehnica, Bucuresti, 1980.
- [4]Novac I., "Masini si actionari electrice" - Ed. Didactica si Pedagogica, Bucuresti, 1982)

#### *Addresses:*

- Eng. Mihaela Răduca, "Eftimie Murgu" University of Romania, Piața "Traian Vuia", nr. 1-4, Reșița
- Prof. Dr. Eugen Răduca "Eftimie Murgu" University of Romania, Piața "Traian Vuia", nr. 1-4, Reșița, [e.raduca@uem.ro](mailto:e.raduca@uem.ro)
- Prof. Dr. Iancu Tătucu "Eftimie Murgu" University of Romania, Piața "Traian Vuia", nr. 1-4, Reșița, [i.tatucu@uem.ro](mailto:i.tatucu@uem.ro)