

NASA/TP-97-206234



# Development of Stitched, Braided and Woven Composite Structures in the ACT Program and at Langley Research Center (1985 to 1997)

## *Summary and Bibliography*

*Marvin B. Dow and H. Benson Dexter*

---

November 1997

## ***The NASA STI Program Office . . . in Profile***

Since its founding, NASA has been dedicated to the advancement of aeronautics and space science. The NASA Scientific and Technical Information (STI) Program Office plays a key part in helping NASA maintain this important role.

The NASA STI Program Office is operated by Langley Research Center, the lead center for NASA's scientific and technical information. The NASA STI Program Office provides access to the NASA STI Database, the largest collection of aeronautical and space science STI in the world. The Program Office is also NASA's institutional mechanism for disseminating the results of its research and development activities. These results are published by NASA in the NASA STI Report Series, which includes the following report types:

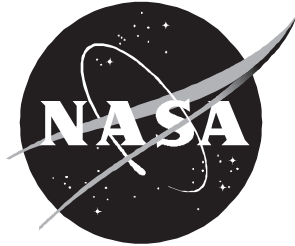
- **TECHNICAL PUBLICATION.** Reports of completed research or a major significant phase of research that present the results of NASA programs and include extensive data or theoretical analysis. Includes compilations of significant scientific and technical data and information deemed to be of continuing reference value. NASA counter-part or peer-reviewed formal professional papers, but having less stringent limitations on manuscript length and extent of graphic presentations.
- **TECHNICAL MEMORANDUM.** Scientific and technical findings that are preliminary or of specialized interest, e.g., quick release reports, working papers, and bibliographies that contain minimal annotation. Does not contain extensive analysis.
- **CONTRACTOR REPORT.** Scientific and technical findings by NASA-sponsored contractors and grantees.
- **CONFERENCE PUBLICATION.** Collected papers from scientific and technical conferences, symposia, seminars, or other meetings sponsored or co-sponsored by NASA.
- **SPECIAL PUBLICATION.** Scientific, technical, or historical information from NASA programs, projects, and missions, often concerned with subjects having substantial public interest.
- **TECHNICAL TRANSLATION.** English-language translations of foreign scientific and technical material pertinent to NASA's mission.

Specialized services that help round out the STI Program Office's diverse offerings include creating custom thesauri, building customized databases, organizing and publishing research results . . . even providing videos.

For more information about the NASA STI Program Office, see the following:

- Access the NASA STI Program Home Page at ***<http://www.sti.nasa.gov>***
- Email your question via the Internet to [help@sti.nasa.gov](mailto:help@sti.nasa.gov)
- Fax your question to the NASA Access Help Desk at (301) 621-0134
- Phone the NASA Access Help Desk at (301) 621-0390
- Write to:  
NASA Access Help Desk  
NASA Center for AeroSpace Information  
800 Elkridge Landing Road  
Linthicum Heights, MD 21090-2934

NASA/TP-97-206234



# Development of Stitched, Braided and Woven Composite Structures in the ACT Program and at Langley Research Center (1985 to 1997)

## *Summary and Bibliography*

*Marvin B. Dow and H. Benson Dexter  
Langley Research Center, Hampton, Virginia*

National Aeronautics and  
Space Administration

Langley Research Center  
Hampton, Virginia 23681-2199

---

November 1997

The use of trademarks or names of manufacturers in this report is for accurate reporting and does not constitute an official endorsement, either expressed or implied, of such products or manufacturers by the National Aeronautics and Space Administration.

---

Available from the following:

NASA Center for AeroSpace Information (CASI)  
800 Elkridge Landing Road  
Linthicum Heights, MD 21090-2934  
(301) 621-0390

National Technical Information Service (NTIS)  
5285 Port Royal Road  
Springfield, VA 22161-2171  
(703) 487-4650

**Contents**

Abstract . . . . . 1

Introduction . . . . . 1

NASA Langley Research in Textile Composites . . . . . 2

    Advanced Material Forms . . . . . 2

    Woven Preforms . . . . . 2

    Multiaxial Knitted Preforms . . . . . 2

    Braided Preforms . . . . . 2

    Powder-Coated Braided Preforms . . . . . 3

    Stitched Preforms . . . . . 3

    Resin Flow Processes and Models . . . . . 3

    Mechanics of Textile Preform Composites . . . . . 3

NASA ACT Program (1988-97) . . . . . 4

    Lockheed Martin Textile Structures Development . . . . . 4

        Wing and Fuselage Concepts . . . . . 4

        Textile Subcomponents for Fuselage Panels . . . . . 4

        Textile Fuselage Structures . . . . . 5

    Northrop Grumman Textile Structures Development . . . . . 5

        Wing Spars . . . . . 5

        Cross-Stiffened Window Belts . . . . . 5

        Fuselage Side Panel . . . . . 5

    McDonnell Douglas Stitched Wing Development . . . . . 6

        Approach to Wing Development . . . . . 6

        Wing Stub Box . . . . . 6

        Semi-Span Wing . . . . . 6

        Advanced Stitching Machine . . . . . 7

        Semi-Span Wing Tests . . . . . 7

        Full-Scale Wing Development . . . . . 7

        Future Wing Manufacturing . . . . . 7

Concluding Remarks . . . . . 8

References . . . . . 9

Appendix A—Definition of Textile Terms . . . . . 31

Appendix B—Bibliography of Composites Reports . . . . . 32

Langley Textiles Research . . . . . 33

    Braiding and Weaving Technology . . . . . 33

    Test Methods for Textile Laminates . . . . . 34

    Tests of Braided and Woven Laminates and Elements . . . . . 36

    Tests of Stitched Laminates and Elements . . . . . 39

    Resin Processing and Modeling Technology . . . . . 43

    Mechanics of Textile Materials and Structures . . . . . 45

    Overviews and Summaries . . . . . 48

ACT Textile Composites Program . . . . .	50
Dow Chemical Company - RTM Resins . . . . .	50
Lockheed Martin - Material and Structural Concepts . . . . .	50
Lockheed Martin - Fabrication Studies . . . . .	51
Northrop Grumman - Material and Structural Concepts . . . . .	53
Rockwell - Mechanics of Materials Studies . . . . .	53
McDonnell Douglas - Structural Design and Analysis . . . . .	54
McDonnell Douglas - Manufacturing Methods Development . . . . .	56
McDonnell Douglas - Advanced Stitching Machine Development . . . . .	58
McDonnell Douglas - Stitched Laminate Test Results . . . . .	58
McDonnell Douglas and Langley - Structural Tests and Analyses . . . . .	59
ACT Program Overviews . . . . .	61
Other Textile Composites Research . . . . .	62
Mechanics of Materials and Structures . . . . .	62
Manufacturing Studies . . . . .	65
Experimental Studies . . . . .	69
Fatigue Studies . . . . .	71
Overviews and Summaries . . . . .	72
Author Index . . . . .	73

## List of Figures

Figure 1. Carbon-epoxy upper aft rudder for DC-10 transport aircraft. . . . .	12
Figure 2. Elements of the Langley Research Center investigation of textile composite materials and structures. . . . .	12
Figure 3. Advanced textile material forms—biaxial knit, multiaxial knit and triaxial weave. . . . .	13
Figure 4. Advanced textile material forms—multiaxial warp knit, triaxial braid, three-dimensional braid and knitted stitched. . . . .	13
Figure 5. Schematic of multiaxial warp knitting machine. . . . .	14
Figure 6. Compression strength data for composite laminates reinforced with multiaxial warp knit carbon tow preforms. . . . .	14
Figure 7. Photograph of a 2-D triaxial braiding machine (typ.). . . . .	15
Figure 8. Schematic of process for making stitching-reinforced composites. . . . .	15
Figure 9. Process steps for making the stitched preform for a damage-tolerant stiffened panel. . . . .	16
Figure 10. Schematic of resin film infusion (RFI) process. . . . .	16
Figure 11. Elements of processing science for textile reinforced composites. . . . .	17
Figure 12. Elements of Langley mechanics of textile-reinforced-composite materials program. . . . .	17
Figure 13. Application of textile reinforced composites in transport fuselage structures. (Lockheed Martin contract). . . . .	18
Figure 14. Three-dimensional integrally woven preform (epoxy-powder-coated tow) for a fuselage panel window belt component. . . . .	18
Figure 15. Completed fuselage panel window belt component. . . . .	19
Figure 16. Completed braided and woven window frames. . . . .	19
Figure 17a. Honeycomb-stiffened fuselage side panel with joggled braided frames. . . . .	20
Figure 17b. Honeycomb-stiffened fuselage side panel with constant-section braided frames. . . . .	20
Figure 18. Woven preform (carbon-PEEK tow) for a wing Y-spar. (Northrop Grumman contract). . . . .	21
Figure 19. Cross-stiffened fuselage window belt component. . . . .	21
Figure 20. Picture frame shear test of cross-stiffened fuselage window belt component. . . . .	22
Figure 21. Cross-stiffened woven/stitched fuselage side panel. . . . .	22
Figure 22a. Stitched/RFI wing panel in Langley 1,200-kip machine for discrete damage tolerance test. . . . .	23
Figure 22b. Stitched/RFI wing panel in Langley 1,200-kip machine for damage repair test. . . . .	23
Figure 23. Stitched/RFI upper cover for wing stub box test component. . . . .	24
Figure 24. Assembly of wing stub box test component. . . . .	24
Figure 25. Stitched/RFI wing stub box test set-up at the Langley Structures and Materials Laboratory. . . . .	25
Figure 26. Design features of stitched/RFI semi-span wing. . . . .	25
Figure 27. Main landing gear attachment test article for stitched/RFI wing. . . . .	26
Figure 28. Advanced stitching machine at Huntington Beach Facility. . . . .	26
Figure 29. Expected evolution of composite stitching technology. . . . .	27
Figure 30. Schematic of stitched/RFI semi-span wing test set-up at the Langley Structures and Materials Laboratory. . . . .	27

Figure 31. Design features of stitched/RFI full-scale wing. . . . . 28  
Figure 32a. Design development test articles for full-scale wing. . . . . 29  
Figure 32b. Design development test articles for full-scale wing—concluded. . . . . 29  
Figure 33. Full-scale wing test arrangement. . . . . 30  
Figure 34. Factory-of-the-future concept for stitched/RFI wings. . . . . 30



## Abstract

*Summary results are presented from the research conducted on woven, braided, knitted and stitched (textile) composites at the Langley Research Center and under the NASA Advanced Composites Technology (ACT) Program in the period from 1985 to 1997. The report also includes an annotated bibliography of 270 U.S. publications on textile composites (with their abstracts). Two major research areas are discussed: (1) the general research in textile composites performed throughout the period under the direction of the Langley Research Center and (2) the development of textile composite aircraft structures by industry under the NASA ACT Program. The annotated bibliography is organized in three subsections: (1) general textiles R&D under the auspices of Langley, (2) ACT Program development of textile structural components, and (3) textiles research by individuals and organizations not associated with the ACT Program. An author index is provided for the reports and documents.*

## Introduction

Since the early 1970s NASA has led the research and development of advanced composite structures for U.S. commercial transport aircraft. Throughout the years, NASA's strategic goal has been to provide the commercial transport builders with the technology and confidence required to make production commitments to composite structures. From modest beginnings at the Langley Research Center, composites became part of a major national program when, in 1976, NASA launched the Aircraft Energy Efficiency (ACEE) Program. The rationale and implementation of the ACEE Program are discussed in reference 1. Conceived in response to a pending fuel cost crisis due to foreign oil embargoes, the ACEE Program aimed to achieve dramatic reductions in airlines fuel consumption by developing energy efficient structures, engines and aerodynamics for U.S. commercial transports.

From 1976 until it ended in 1985, the ACEE Program was the centerpiece of NASA composites research. The goal of the program was to accelerate the application of composite primary structures in new civil transport aircraft. To meet that goal, research contracts were let with Boeing, Douglas and Lockheed to (1) develop design and manufacturing methods for empennage, wing and fuselage structures and (2) conduct flight service evaluations of composite structures. Figure 1 shows a carbon-epoxy rudder, developed by Douglas, being readied for flight service. Also during the ACEE period, traditional, or base, research was performed at Langley or under numerous grants and contracts. The goal was to provide an engineering and science base for composite materials and structures. A summary of NASA research and development in the ACEE era (1975 to 1986) is given in reference 2 which also contains an annotated bibliography of over 600 technical reports produced in the period.

Without question, the ACEE Program provided the airframe companies with important technology, but the program ended without accomplishing its original goal of developing composite primary wing and fuselage structures. Without a NASA technology program, industry lacked the confidence to proceed with production of high-risk primary structures. The barrier issues were high acquisition costs and low damage tolerance. Cost data extrapolated from the ACEE development contracts showed that wings and fuselages would cost considerably more than aluminum structures. The industry position on production commitment was that composite primary structures must be demonstrated to cost less than aluminum structures. Low damage tolerance remained a characteristic of composite structures despite major efforts to develop and use toughened matrix resins. Industry wanted robust structures able to withstand the rigors of flight service with minimal damage.

The cost and damage tolerance barriers to composite primary structures became forcing functions as researchers turned to new concepts in composites which would incorporate the manufacturing methods of the textiles industry and which would incorporate through-the-thickness reinforcements. Supporters of the new concepts argued that only breakthrough technology could overcome the long standing problems with conventional laminated composites. The new composite structures would be made using woven, knitted, braided or stitched (textile) carbon tows to make a dry preform which, after resin transfer molding, would produce a composite with through-the-thickness reinforcements. In theory, the new composites could be made cost effective by adapting the automated fabrication processes and quality control methods of the existing textiles industry. By 1985, research engineers at NASA Langley were holding conferences to explore the potential of textile composites, reference 3. But, it was the start of NASA's Advanced

Composites Technology (ACT) Program in 1988, reference 4, that gave major impetus to textile structures. The ACT Program funded contracts with major aerospace companies for textile structural components and funded a concurrent research effort by government, industry and universities to provide an engineering and science base for textile composites.

This report presents a summary of the achievements and problems during the development of woven, braided and stitched composites in the period from 1985 to 1997; it includes an annotated bibliography of the publications on textile composites (with their abstracts). The report is organized to cover two major research areas: (1) the general research in textile composites performed throughout the period under the direction of the Langley Research Center and (2) the development of textile composite aircraft structures by industry under the NASA ACT Program. The annotated bibliography of over 290 publications is organized in three subsections: (1) general textiles R&D under the auspices of Langley, (2) ACT Program development of textile structural components, and (3) textiles research by individuals and organizations not associated with the ACT Program. An author index is also provided for the reports and documents.

Note: As an aid to readers, Appendix A provides definitions of textiles terminology used in subsequent sections of this report.

## **NASA Langley Research in Textile Composites**

In the early 1980s, Langley Research Center began to explore the potential of textile processes for producing cost-effective and damage tolerant aircraft primary structures. Langley concentrated on adapting industry methods to make textile composites with a reinforcement preform of dry carbon tows made using weaving, knitting, braiding, or stitching processes. The preform would be filled with epoxy resin in a resin transfer molding (RTM) or resin film infusion (RFI) operation. Finally, as with conventional composites, the part would be cured using heat and pressure. Figure 2 depicts the broad scope of the Langley investigation which included textile preforms and processes, fabrication studies, analysis development and extensive experiments. The following paragraphs are a summary of the Langley efforts to develop the science of textile composites.

### **Advanced Material Forms**

From the outset, the approach was to use materials and processes that could be automated in actual production and, thus, eliminate labor intensive operations from all phases of composites fabrication. The various advanced material forms shown in figures 3 and 4 were examined and evaluated for use in carbon tow preforms.

Despite their serious deficiencies as stand-alone preforms, biaxial woven and knitted fabrics were considered because they were available from commercial sources.

### **Woven Preforms**

In order for woven preforms to be useful in practical composite laminates, they had to provide the shear stiffness lacking in the biaxial fabrics readily available from the textiles industry. The requirements for a useful multi-axial weave were determined in a study reported in reference 5. Because a triaxial weave of the desired configuration (see figure 3) was not available from commercial sources, Langley researchers sought industry expertise, money and machines to produce practical multi-axial woven carbon tow preforms. For that purpose, several Fiber-Tex conferences and workshops were held to acquaint the textiles industry with the Langley requirements (see reference 6 for example). However, the textiles industry viewed woven carbon fabrics as a minuscule market and not worth the investment of their money and expertise. NASA opted to stop attempts to develop multi-axial carbon tow weaves.

### **Multiaxial Knitted Preforms**

Although the concept of multi-axial weaves was discarded, the desired triaxial preform properties were available in multi-axial warp knit fabric, figure 4. This knitted preform consists of warp ( $0^\circ$ ), fill ( $90^\circ$ ) and bias ( $\pm 45^\circ$ ) tows held together by knitting through the thickness of the fabric. An example of a commercial warp knitting machine is shown in figure 5. Warp knitting combined with stitching for through-the-thickness reinforcement lends itself to forming useful preforms. Assemblies of tows that represent repeating elements, called stacks, can be oriented and stitched together to form the desired preform thickness and orientation. Langley compiled test data, figure 6, from warp knit preform composites to identify the preforms providing the best combination of strength and damage tolerance properties. Subsequently, McDonnell Douglas used these data in selecting a warp knit fabric for composite wing fabrication.

### **Braided Preforms**

Braiding of carbon tows (see figure 7) provides a multi-axial preform and in the 3-D configuration provides through-the-thickness reinforcement which, in turn, produces composite laminates with excellent damage tolerance, reference 7. However, the reinforcement feature of 3-D braids which provides damage tolerance results in low in-plane strengths. Early on the Langley researchers determined that existing commercial braiding machines could not economically produce large area

preforms. Later investigations of aircraft fuselage and wing structures by Lockheed Martin and Northrop Grumman showed that braids are extremely useful in special applications such as window belts, curved fuselage frames and wing stiffening elements where flexibility and damage tolerance are essential. McDonnell Douglas Aerospace adopted braiding for the preforms of the blade-section stiffeners on wing covers.

### **Powder-Coated Braided Preforms**

Seeking means to make composites without recourse to RTM, Langley devoted considerable effort to the development of epoxy-powder-coated carbon tow technology. The approach was to coat carbon tows with epoxy powder, braid the tows into a preform, place the preform in tooling and cure a net-shape part. Numerous problems attended the development including quality control of the coating, abrasion and friction during the braiding, and the preform bulk factor during processing. By using clever fabrication techniques, some success was achieved in overcoming the problems. Under NASA direction, Lockheed Martin was able to use the epoxy-powder coated carbon tow technology developed by Langley, reference 8, for fabricating braided structures.

### **Stitched Preforms**

Stitching has long been known to have important uses in enhancing the strength and damage tolerance of composite structures. Saunders, an English builder, obtained a patent in 1898 for a process of using copper wires to stitch thin layers of wood for a boat hull. Results are reported in reference 9 from an investigation of carbon/epoxy composites reinforced by steel wires. Several military aircraft programs have stitched carbon/epoxy prepreg with Kevlar thread to enhance the structural integrity and damage tolerance of thin composite structures. But attempts to stitch thick prepregs required for transport wing structures, reference 10, revealed serious limitations to the method.

From the early to mid-1980s, Douglas Aircraft Company, references 11 and 12, investigated and patented revolutionary stitched preforms and reinforced composite laminates. The Douglas process, depicted in figure 8, consists of stitching a dry carbon fabric preform, filling the preform with epoxy resin and curing the laminate under heat and pressure. Langley tests of Douglas laminates, reference 13, showed that stitched laminates had outstanding damage tolerance, acceptable fatigue performance and good strength properties. Among the competing textile processes, NASA judged stitching to have the greatest potential for the manufacture of cost-effective and damage tolerant structures.

In a cooperative effort, the Langley research was expanded to provide an engineering basis for stitching designs, reference 14. These tests also included stiffened panels, figure 9, in which the entire structure was reinforced with through-the-thickness stitching to provide global damage resistance. For stiffened panels, Douglas adopted an epoxy resin film infusion process, figure 10. Results are reported in reference 15 from tests to determine stiffener pull-off strengths and failure modes. Also, Langley tested, reference 16, warp knit fabrics and braids to provide a materials database for wing design modifications. Later sections of this report cover Langley tests and analyses of large structural panels and a wing stub box, see references 16 and 17 for example. Engineers at Langley and McDonnell Douglas made substantial advancements in the structural analysis of stitched wing components.

### **Resin Flow Processes and Models**

From the outset of investigating textile composites, Langley researchers recognized that computer models of resin flow into the preforms and sensors to measure the location and state of the resin flow front were essential for the practical manufacture of textile composite aircraft structures. Under NASA grants, Professors Loos (VPI&SU) and Kranbuehl (William and Mary) began early research, references 19 and 20, in resin flow model and sensor development. The types of investigations involved in the process modeling are depicted in figure 11. At Langley, researchers provided experimental data for the modeling and sensor efforts, reference 21, and investigated resin transfer molding (RTM) and resin film infusion (RFI) tooling concepts and processes. Part of the investigation dealt with new and developmental epoxy resins. Although several resins exhibited useful properties, none produced a combination of properties and cost advantages equal to the Hercules 3501-6 resin, the baseline in all evaluations. Considering the enormous database of properties required for a new resin to be used in a commercial transport, 3501-6 resin remained unchallenged for actual applications.

### **Mechanics of Textile Preform Composites**

As reported in reference 22, Langley planned and implemented a multifaceted (see figure 12) mechanics-based design methodology program for textile composites. First, standard test methods were established for measuring material properties and design allowables. Existing standard test methods for tension, compression and shear properties were evaluated and specialized for textile composites. New test methods were developed to measure impact damage resistance and through-the-thickness strength. Second, mechanics models were developed to predict how fiber preform architectures and

constituent properties affect engineering moduli, strength, damage resistance and fatigue life. Micromechanics models (see reference 23 for example) were developed to predict the effects of fiber architecture on local stress and strain behavior. Third, an extensive experimental program was conducted to identify damage mechanisms and to provide data for semi-empirical methods for predicting strength and fatigue life, reference 24.

### **NASA ACT Program (1988-97)**

After the ACEE Program ended in 1985, NASA and industry managers began rallying support for renewed development of composite wing and fuselage primary structures. By 1987, funds were available for a modest expansion of the Langley composites program. A NASA Research Announcement (NRA) was issued seeking proposals for innovative approaches to cost-effective fabrication, enhanced damage tolerance designs, and improved analysis methods. Forty-eight proposals were submitted by companies and universities; fifteen proposals were selected for contracts. Then, in 1988, NASA launched its Advanced Composites Technology (ACT) Program, a major new program for composite wing and fuselage primary structures. The program incorporated the existing NRA contracts with significant increases in funding for wing and fuselage hardware developments. A small Structures Technology Program Office at Langley provided administrative management for the ACT Program.

The objective of the ACT Program was to develop an integrated "affordable" composites technology data base that will provide the impetus for a more rapid and timely transition of this technology into production aircraft. Besides textile composites, the ACT program provided funds for wide ranging investigations of composite materials and structures. The contractors and their areas of investigation are listed in Table 1. The Boeing Company chose to focus its fuselage work on the application of automated tow placement as a low-cost fabrication method. Several other contractors investigated design methods or new RTM materials and processes, e.g. powder coated prepreg. Under the Rockwell contract, important achievements were made in the structural mechanics of stitched composites and the reports are included in the annotated bibliography. Subsequent sections of this report summarize contract work by Lockheed Martin, Northrop Grumman and McDonnell Douglas which dealt directly with the design and fabrication of textile composite aircraft structures. Except for the two wing development contracts with McDonnell Douglas where work continues, the ACT contracts are completed.

### **Lockheed Martin Textile Structures Development**

**Wing and Fuselage Concepts.** Early in its contract work, Lockheed (later Lockheed Martin) investigated new and innovative concepts for wing and fuselage primary structures. The new concepts were aimed to secure the advantages of improved organic matrix composite materials and evolving fabrication techniques. In a concept assessment of wing and fuselage structures, Lockheed Martin examined four wing and three fuselage concepts using the L-1011 transport as a design baseline. As described in reference 25, four wing concepts were studied: No. 1 was a modular wing consisting of automatic tape placed cover skins, pultruded stiffeners, filament wound spars and press formed ribs; No. 2 was a stitched/woven wing made up of upper and lower pieces each formed by resin transfer molding; No. 3 was an advanced tow placement wing; and No. 4 was a braided wing formed of 2-D and 3-D braids. The stitched/woven wing concept was rejected because it posed major tooling uncertainties and cost risk. The braided one-piece wing was rejected because no existing machine was anywhere near the size required nor was any such machine planned. On the basis of cost and weight trade studies, the advanced tow placement wing was selected as the preferred structural candidate. The three fuselage concepts studied are also described in reference 25. No. 1 was a sandwich stiffened shell consisting of a sandwich using braided triangular tubes as the core; No. 2 was a geodesic fuselage using an isogrid stiffened shell; and No. 3 was a hat stiffened design consisting of tow placed skins with pultruded hat stiffeners. On the basis of cost and weight trade studies, Concept No. 3 was selected as the preferred structural candidate. Given the considerable maturity of tow placement technology, NASA judged the preferred structural concepts as deficient in innovative characteristics and not suitable for development.

#### ***Textile Subcomponents for Fuselage Panels.***

NASA directed Lockheed Martin to investigate textile preforms, resin transfer molding and powder resins for application in fuselage structures, and to fabricate textile structural subcomponents for large test panels Boeing would fabricate under its ACT contract. To that end, Lockheed Martin participated on Boeing Design Build Teams for keel and window belt panels on the Boeing 767X baseline airplane. Lockheed Martin investigated seven textile preforms including woven fabrics, braids, multiaxial warp knit fabric and near-net-fiber placement and the results are reported in reference 26. Also, Lockheed Martin evaluated candidate epoxy resins for resin transfer molding and for dry powder prepregging. Details of the evaluation tests and results obtained are given in reference 27.

**Textile Fuselage Structures.** Using Boeing baseline loads and fuselage sizes, Lockheed designed, built and tested the textile preform structural subcomponents, figure 13, including circumferential fuselage frames, window belt reinforcement, keel frames, skin/stiffened and honeycomb stiffened fuselage side panels. For composite frames, Lockheed evaluated various 2-D and 3-D braiding processes and designs and chose a 2-D triaxial braiding process for fabrication trials. Frames were fabricated for large test panels to be built by Boeing and by Lockheed. Production plans were developed and cost analyses were performed which showed significant cost advantages for the braided frames.

For skin-stringer fuselage side panels, window belt designs were devised incorporating braided and woven preforms and several window belt panels were fabricated using epoxy-powder coated carbon tows, figures 14 and 15. Using Boeing keel panel designs, Lockheed designed frames and beams incorporating textile preforms for the keel panels. Details of this work are presented in reference 28. Later, window belts were designed for honeycomb stiffened fuselage side panels and braided and woven window frames, figure 16, were made and tested.

As part of a cooperative effort with Boeing to develop honeycomb fuselage panels, Lockheed fabricated the two large honeycomb panels shown in figures 17a and 17b. The panels incorporate two different designs for the window belt region. In one design, figure 17a, the window belt region consists of skin material without honeycomb core material. The design requires joggled fuselage frames. In the second design, figure 17b, honeycomb extends through the window region with individual window frames inserted through the honeycomb. The design accommodates constant-section fuselage frames. Lockheed textile concepts were used for the circumferential fuselage frames and window frames whereas the skins were made using advanced tow placement methods developed under the ACT Program. The NASA Langley Research Center will test the panels in special test fixtures which will apply combined pressure loads and in-plane loads.

### **Northrop Grumman Textile Structures Development**

**Wing Spars.** In its ACT contract, Grumman (later Northrop Grumman) devised advanced wing designs that integrated new material forms with innovative structural concepts and cost-effective fabrication methods. A representative wing spar selected from a baseline aircraft was designed to be fabricated using carbon tows in textile preforms. Knitting, weaving and stitching processes were employed in making the preforms. The preforms were made into spars through resin transfer molding, resin

film infusion or consolidation of commingled thermoplastic and carbon tows. To validate the structural performance predictions, the spars were subjected to four-point beam bending tests. Details are given in reference 29.

Because of inherent limitations with the weaving process and machines, preforms for the woven spars required stitching to attach the  $\pm 45^\circ$  degree plies to a central woven carcass of  $0^\circ/90^\circ$  tows. Grumman investigated woven stitched preforms made with various material combinations. Figure 18 shows a section from the Grumman concept for a woven Y-spar preform made from commingled carbon/thermoplastic (PEEK) tows. After fabrication and tests were completed, Grumman concluded that the best manufacturing approach was to make the spars using a knitted/stitched preform and the resin film infusion process. It is noted that this recommended manufacturing method is similar to the method McDonnell Douglas Aerospace chose for making composite wing boxes.

**Cross-Stiffened Window Belts.** In the technology development contract, Northrop Grumman sought innovative means to design and fabricate composite structures having intersecting stiffening members. This construction, which Northrop Grumman identifies as cross stiffening, is common in airframe components such as bulkheads, doors, skin panels and window belts. The goal of the Northrop Grumman investigation (see reference 30 for details) was to provide structural continuity through the stiffener intersections of a cross-stiffened composite structure. A transport fuselage window belt panel was chosen as the technology demonstration structure. For evaluation of the concept, a 38-in. by 62-in. test component was fabricated. The preform was an assembly consisting of two primary longitudinal members, six transverse stiffeners and a skin. The intersections of the longitudinal and transverse members had continuous carbon tows through the intersections to provide structural continuity. The entire assembly was stitched to stabilize the dry preform and to add damage tolerance to the final structure. Figure 19 shows the cured window belt component with two window cutouts. A successful picture frame shear test, figure 20, was performed on the component.

**Fuselage Side Panel.** Northrop Grumman applied the cross-stiffened stiffening concept to a fuselage side panel sized for transport loads provided by Boeing. Details of the panel design and fabrication are presented in reference 31. Figure 21 is a photograph of the completed curved panel which has dimensions of 60-in. by 90-in. and a radius of 122-in. The panel skin is stitched with strong thread in a closely spaced array of through-the-thickness reinforcements. The woven stringers and

frames have continuous tows through the intersections to provide structural continuity. The panel awaits testing at the Langley Research Center in a new test fixture that will simultaneously apply longitudinal compression loads, internal pressure loads and in-plane shear loads.

### **McDonnell Douglas Stitched Wing Development**

Under its ACT contract, Douglas Aircraft Company (later McDonnell Douglas Aerospace) developed the stitched/resin film infusion (RFI) process into a manufacturing method for making primary wing structures for transport aircraft. Douglas pursued a “design-build-team” approach to devise a damage tolerant and cost competitive composite structure. In the process, compromises were established between design, reference 32, and manufacturing, reference 33. Examples of this integration approach are: wing cover panels have blade stiffeners to simplify the fabrication tools; skin and stiffeners have the same lay-up to lessen thermal distortion; skin and stiffeners have dense stitching for damage tolerance and for resin infiltration; and stiffener flanges are stitched to the skin to help improve location accuracy and to help prevent separations due to out-of-plane loads.

**Approach to Wing Development.** Douglas/MDA used a building block approach in progressing from elements, to panels, to a wing stub box. Although various epoxy resins were evaluated, none were found to have properties and cost advantages matching the Hercules 3501-6 resin used from the outset of the development. Test articles, of ever increasing size, were built to demonstrate that stitched/RFI structures could be fabricated and that they met the design requirements for strength, damage tolerance and repairability. As part of the demonstration, large tension and compression panels were fabricated at Long Beach, California and tested at NASA Langley. Tests procedures and the results are described and discussed in reference 34. In the technology demonstration, considerable attention was given to showing that stitched panels could meet FAA damage criteria requirements and that damaged panels could be restored to design ultimate strength. For example, figures 22a and 22b show a discrete damage test panel and a repair test panel, respectively, in the Langley 1,200 kip compression-tension machine. To promote realism in some of the repair tests, aircraft technicians from the American Airlines facility in Tulsa, Oklahoma traveled to Langley to install mechanical repairs.

**Wing Stub Box.** Successful design, fabrication and testing of the wing stub box were major accomplishments in the ACT Program. The stub box (with a span of 12-ft. and a side-of-body chord of 8-ft.) was designed with stitched upper and lower covers (including skin,

blade-stiffeners, spar caps and intercostals as integral structures). Cover preforms were stitched on two machines, reference 33, made for MDA by Pathe Technologies, Inc. The integral cover design permitted the use of relatively simple stiffened plates for the spar and rib webs. Fabrication of the wing demonstrated successful scale-up of the stitched/RFI process from panels to an integral wing cover, figure 23, featuring heavy spar caps, intercostals and stiffeners with runouts. Moreover, the stub box incorporated lessons learned in the fabrication of panels and from an ongoing process development. For example, the uniweave fabric used for panel preforms caused many handling and lay-up problems; and, therefore, it was replaced with multiaxial warp knit fabric. The stub box fabrication and assembly are described in reference 35 and the assembled stub box is shown in figure 24 with the steel test attachment fixture at one end.

The assembled stub box was shipped to Langley where, in July 1995, NASA performed a series of static loading tests. Figure 25 shows the box ready for testing after being bolted to the massive steel backstop in the Structures and Materials Laboratory. Upbending loads were applied to the tip of the steel loading fixture which was designed to apply the correct load distribution to the composite structure. The tests included a Design Limit Load (DLL) test with easily visible impact damage at a design critical location. Prior to an ultimate load test, the visible damage was repaired in-place by American Airlines technicians using mechanically fastened repair plates. The stub box failed at a load of 143 percent of DLL in the region near the attachment to the steel loading fixture; a location well away from the repair site. Details of the tests are presented in reference 36. Pre-test and post-test analyses of the wing box are reported in reference 37.

**Semi-Span Wing.** In 1993, the stitched/RFI wing development contract was expanded to include the design, fabrication and test of a 41-ft. semi-span composite wing shown schematically in figure 26 with some of its design features. NASA and MDA consider this wing a necessary step in the building block approach to a full-scale wing. In size and complexity, the semi-span wing is a major scale-up of the wing stub box technology. In contrast to the composite stub box which had flat covers, the semi-span wing, reference 38, will have aerodynamically contoured covers, a lower cover with an aerobreak along the span, a simulated engine pylon attachment and a simulated landing gear attachment. New tooling concepts and computer models are being devised and verified to meet the fabrication challenge posed by the semi-span wing. Design verification is being achieved from large design development test articles such as the main landing gear attachment shown in figure 27. But, the

most complex and difficult task in the fabrication scale-up is the advanced machine required to stitch the large, integral covers of the semi-span wing.

**Advanced Stitching Machine.** MDA awarded a contract for design, fabrication and checkout of the advanced stitching machine to Ingersoll Milling Machine Co. which subcontracted with Pathe Technologies, Inc. for the four stitching heads and bobbins. Details of the machine and its capabilities are presented in references 39 and 40. Figure 28 shows the completed machine which is installed at the MDA manufacturing facility in Huntington Beach, California. The machine features high speed stitching capability with advanced automation allowing it to stitch large, thick, complex wing structures without manual intervention. The machine is capable of computer controlled stitching of integral preforms (covers, stiffeners, spar caps and rib caps) for aerodynamically contoured wings up to fifty feet in span and ten feet wide. Various aspects of the stitching operation are controlled by the 38 individual computers on the machine. Computers simulate and confirm the stitching patterns prior to the actual operations. Other computers control and synchronize the motions and stitching by the four heads and time the stitching with movement of the 50 lift tables which support the heavy preform during stitching. Despite its capabilities, the present machine is an engineering prototype and, as depicted in figure 29, is a step in the evolution of stitching from a laboratory curiosity to the serial production of wing preforms.

**Semi-Span Wing Tests.** After assembly at MDA, the semi-span wing box will be shipped to Langley for a series of tests by NASA. Figure 30 shows a schematic of the Langley test set-up. The wing will be mounted on the same steel backstop used in testing the wing stub box. The testing, expected to begin in 1998, will include up-bending, down-bending and torsion loads applied to the structure in accordance with a detailed test plan. Strain measurements will be made at several hundred interior and exterior locations on the structural box. Impact damage will be induced at design critical locations on the wing box. Repairs will be made to the induced damage to demonstrate restoration of the full design load capability. In addition to validating design and fabrication approaches, the semi-span wing will provide vital data to validate the predictions of wing cost and structural behavior.

**Full-Scale Wing Development.** In 1994, NASA obtained authority to proceed with the final phase of the wing program—the technology verification of a full-scale wing. McDonnell Douglas Corporation proposed to use their stitched/RFI process in a design and build approach to a full-scale composite wing for a twin-

engine derivative transport with fuselage mounted engines. MDC design studies had shown that a high aspect ratio, supercritical composite wing could provide major performance benefits for the derivative transport. Indeed, without a composite wing, the transport would have little market value. NASA viewed the derivative transport as a near-term target of opportunity for the first production application of composite wing technology. Work on the full-scale wing began in September 1995.

Figure 31 shows the design configuration of the full-scale composite wing which includes left and right hand outer wing boxes, each with a span of 41 feet, and the center wing section with a length of 10 feet. Wing design is in progress and details are presented in references 41 and 42. The design of the wing includes studies of the materials and structural details of the substructure elements, i.e. spar and rib webs, concentrated load transfer details, etc. The wing development includes a large effort on design development test articles intended to provide critical data to validate the design and fabrication approaches. As shown in figures 32a and 32b, these articles cover a diverse array of issues ranging from major load transfer, to fuel leakage to lightning protection. Under terms of a Memorandum of Agreement with Langley, MDC is responsible for the entire cost of several of the design development test articles.

To provide the proper boundary conditions for structural tests, the composite wing will be joined as shown in figure 33 to a barrel section from an aluminum fuselage salvaged from a MD-80 transport. Jacks will be used to apply test loads in accordance with a test plan that will explore the strength and repair capabilities of the composite wing. Tests will be performed in MDC facilities; the present schedule calls for the completion of tests in 2001.

**Future Wing Manufacturing.** To the extent practical, each step in making the semi-span and full-scale wings reflects an approach to wing serial production. Figure 34 shows the wing manufacturing plan in a factory-of-the-future. In addition to the stitching machine, the MDA facility at Huntington Beach houses state-of-the-art wing manufacturing equipment purchased with McDonnell Douglas Corporation money as part of a cooperative effort to advance manufacturing technology. The equipment includes precision cutting equipment, preform stacking tables, laser positioning devices and preform handling fixtures.

MDA cost studies show that their fabrication concept will produce transport wings that provide the known attributes of composites, e.g., reduced weight, fatigue and corrosion resistance, at costs substantially lower than conventional aluminum construction. But to achieve the

cost advantage it is essential to incorporate real-time quality control and assurance in every step of the fabrication process. To that end, MDA will incorporate the following procedures in the wing manufacture:

- The warpknit carbon fabric preform stacks will be machine made and certified for quality.
- The preform stacks will be cut and placed by computer controlled machines.
- A computer controlled stitching machine will locate the preform details with aerospace precision, insert thousands of reinforcing stitches and make a permanent record of actual stitch insertions.
- The tooling will be of a type adaptable for later handling by robots.
- The resin film infusion process will be guided by verified 3-D computer models of the time-temperature and pressure profiles.
- The post-cure inspection will be done using an existing machine which looks only for large area defects.

## Concluding Remarks

In the period from 1985 to 1997, NASA conducted a comprehensive development of woven, knitted, braided and stitched materials and structures for application on the primary structures of commercial transport aircraft. This report presents a summary of the achievements, problems and failures in the development of textile composites; and it includes an annotated bibliography of 270 publications on textile composites (with their abstracts). The textiles development supports the following conclusions.

- The most cost-effective and structurally practical application of textiles is a combination of the stitching of dry carbon fabrics and resin film infusion molding.
- Practical textile structures will be a combination of materials and processes. The stitched wing incorporates multi-axial warp knit preform stacks, braided stiffeners and global stitching for damage tolerance and ease of assembly.
- The use of an integral stitched carbon preform and the resin film infusion process eliminates problems with worker exposure and resin shelf life during manufacturing operations.
- Multi-axial woven carbon tow materials are not available from commercial sources and, therefore, do not warrant further development.

- Braided materials are extremely useful in special applications such as window belts, curved fuselage frames and wing stiffening elements where flexibility and damage tolerance are essential. But, braided structures are not practical for large, planar structures.
- Several new commercial epoxy resins are suitable for resin transfer molding or resin film infusion but none challenge the old, well characterized resins in terms of properties combined with cost.
- Important advances have been made in the structural analysis of primary wing structures and in predicting the response of composite structures under various loads.
- Research remains to be done in the area of fracture mechanics methodology to establish a solid engineering basis for predicting failure modes and mechanisms in stitched structures.

Research and development by Lockheed Martin and by Northrop Grumman showed that textile structural concepts were particularly adaptable for application in fuselage frames and window belts which are subjected to complex loads in service. But, the ACT Program no longer includes full-scale fuselage development. Thus, it appears that a composite transport fuselage is a distant dream for its proponents.

However, the successes achieved in developing a stitched/resin film infused wing lend near-term reality to the dreams of wing proponents. McDonnell Douglas Corporation has chosen a revolutionary fabrication concept to make cost-competitive composite wings. Stitched structures have been demonstrated to carry design loads in compression and tension, to withstand discrete source damage, and to be easily repaired to ultimate load capability with bolted-on repair plates. NASA should press on and complete the work and, thus, verify the cost and performance of composite wings in the only way acceptable to the transport builders and their customers.

For decades, a NASA goal has been a production commitment to composite primary structures in U.S. commercial transports. With a material density one-half that of aluminum, composite airframe structures offer major weight savings in transports. Weight savings translate into transport operating performance gains unmatched by any other known technology improvements. The textile composites technology which NASA is developing in the ACT Program provides the means to overcome past barriers to acceptance and will, when completed, make primary structures a practical reality.



## References

1. Povinelli, F. P.; Klineberg, J. M.; and Kramer, J. J.: Improving Aircraft Energy Efficiency. *Astron. & Aeron.*, vol. 14, no. 2, Feb. 1976, pp. 18–31.
2. Dow, M. B.: *The ACEE Program and Basic Composites Research at Langley Research Center (1972–1986)*. NASA RP-1177, 1987.
3. Dexter, H. B.; Campaniles, E. T.; and Peebles, L., compl. and eds.: *3-D Composite Materials*. NASA CP-2420, 1985.
4. Davis, J. G., Jr.: *Overview of the ACT Program*. NASA CP-3154, 1992, pp. 3–25.
5. Dow, N. F.; and Henstenburg, R. B.: *Development of Through-the-Thickness Reinforced Triaxially Woven Composites Laminated Reinforcements*. NASA CR-187511, 1991.
6. Dexter, H. B.; and Stein, B. A.: *Advanced Composite Materials for Airframe Structures. Fiber-Tex 1987*. NASA CP-3001, Part 1, 1988, pp. 1–29.
7. Fedro, M. J.; Gunther, C.; and Ko, F. K.: *Mechanical and Analytical Screening of Braided Composites*. NASA CP-3104, Part 1, 1991, pp. 677–704.
8. Hugh, M. K.; Marchello, J. M.; Hartness, J. T.; Goodwin, S.; Shukla, J. G.; and Johnson, N. J.: Textile Composites From Powder-Coated Towpreg: Yarn Treatment for Braiding. *Moving Forward With 50 Years of Leadership in Advanced Materials—Proceedings of the 39th International Symposium and Exhibition*, Book 1, SAMPE, Apr. 1994, pp. 551–559.
9. Huang, S. L.; Richey, R. J.; and Deska, E. W.: Cross Reinforcement in a GR/EP Laminated. *American Society of Mechanical Engineers, Winter Meeting*, Dec. 1978.
10. Smith, P. J.; Wilson, R. D.; and Gibbins, M. N.: *Damage Tolerant Wing Panels for Transport Aircraft*. NASA CR-3951, 1985.
11. Palmer, R. J.: Resin Impregnation Process. U.S. Patent 4,311,661, Jan. 1982.
12. Palmer, R. J.: Woven Layered Cloth Reinforcement for Structural Components. U.S. Patent 4,410,577, Oct. 1983.
13. Dow, M. B.; Smith, D. L.; and Lubowinski, S. J.: An Evaluation of Stitching Concepts for Damage Tolerant Composites. *Fiber-Tex 1988*. NASA CP-3038, 1989, pp. 53–73.
14. Dow, M. B.; and Smith, D. L.: Damage-Tolerant Composite Materials Produced by Stitching Carbon Fibers. *Advanced Materials. The Big Payoff—21st International Technical Conference*, SAMPE, 1989, pp. 595–605.
15. Deaton, J. W.; Kullerd, S. M.; Madan, R. C.; and Chen, V. L.: Test and Analysis Results for Composite Transport Fuselage and Wing Structures. *Ninth DOD/NASA/FAA Conference on Fibrous Composites in Structural Design*. NASA CP-3154, 1992, pp. 169–193.
16. Dexter, H. B.; Hasko, G. H.; and Cano, R. J.: Characterization of Multiaxial Warp Knit Composites. *First NASA/DOD Advanced Composites Technology Conference*. NASA CP-3104, Part 1, 1991, pp. 589–619.
17. Jegley, D. C.; and Waters, W. A., Jr.: *Test and Analysis of a Stitched/RFI Graphite-Epoxy Panel With a Fuel Access Door*. NASA TM-108922, 1994.
18. Wang, J. T.: *Global and Local Stress Analyses of McDonnell Douglas Stitched/RFI Composite Wing Stub Box*. NASA TM-110171, 1996.
19. Claus, S. J.; and Loos, A. C.: RTM Process Modeling for Textile Composites. *Fiber-Tex 1988*. NASA CP-3038, 1989, pp. 349–365.
20. Kranbuehl, D. E.; Eichinger, D.; Williamson, A.; Levy, D.; Reyser, M.; Kingsley, P.; Hart, S.; and Loos, A. C.: On-Line, In-Situ Control of the Resin Transfer Molding Process. *Advanced Materials: The Challenge for the Next Decade—35th International Symposium and Exhibition*, Book 1, SAMPE, 1990, pp. 825–834.
21. Hasko, G. H.; Dexter, H. B.; and Weideman, M. H.: Resin Transfer Molding of Textile Preforms for Aircraft Structural Applications. *Ninth DOD/NASA/FAA Conference on Fibrous Composites in Structural Design*, FAA Report DOT/FAA/CT-92-25, III, Nov. 1991, pp. 1303–1317.
22. Poe, C. C., Jr.; and Harris, C. E., eds.: *Mechanics of Textile Composites Conference*, Parts 1 and 2, NASA CP-3311, 1995.
23. Naik, R. A.: Failure Analysis of Woven and Braided Fabric Reinforced Composites. *Fifth NASA/DOD Advanced Composites Technology Conference*, NASA CP-3294, Vol. 1, Part 2, 1995, pp. 571–613.
24. Poe, C. C., Jr.; Harris, C. E.; Coats, T. W.; and Walker, T. H.: Tension Strength With Discrete Source Damage. *Fifth NASA/DOD Advanced Composites Technology Conference*, NASA CP-3294, Vol. 1, Part 1, 1995, pp. 369–436.
25. Chu, R. L.; Bayha, T. D.; Davis, H.; Ingram, J. E.; and Shukla, J. G.: *Advanced Composite Structural Concepts and Materials Technologies for Primary Aircraft Structures—Design/Manufacturing Concept Assessment*. NASA CR-4447, 1992.
26. Shukla, J. G.; and Wu, S. Y.: *Advanced Composite Structural Concepts and Materials Technologies for Primary Aircraft Structures—Textile Preform Development and Processing*. NASA CR-4728, 1996.
27. Shukla, J. G.; Wu, S. Y.; and Bayha, T. D.: *Advanced Composite Structural Concepts and Materials Technologies for Primary Aircraft Structures—Advanced Resin Systems for Textile Preforms*. NASA CR-194968, 1994.
28. Jackson, A. C.; Barrie, R. E.; Adams, L. T., Jr.; Chu, R. L.; Kwon, Y. S.; Ott, L. M.; Shah, B. H.; Shukla, J. G.; and Skolnik, D. Z.: *Advanced Composite Structural Concepts and Materials Technologies for Primary Aircraft Structures—Design, Analysis, Fabrication and Test*. NASA CR-4726, 1996.
29. Suarez, J. A.; and Buttitta, C.: *Novel Composites for Wing and Fuselage Applications: Task 1—Novel Wing Design Concepts*. NASA CR-198347, 1996.

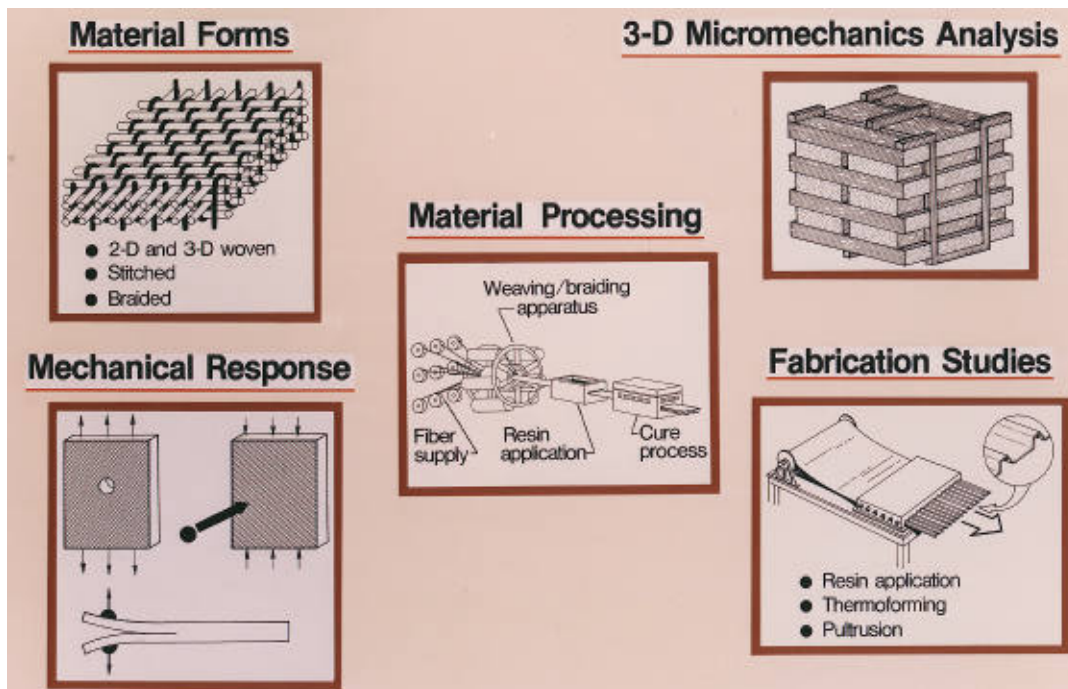
30. Suarez, J. A.; and Buttitta, C.: *Novel Composites for Wing and Fuselage Applications: Textile Reinforced Composites and Design Guidelines*. NASA CR-201612, 1996.
31. Suarez, J. A.; Sobel, L. H.; Egensteiner, W. A.; and Feldman, S. M.: Design, Analysis and Fabrication of Cross-Stiffened Primary Structure. *Fifth NASA/DOD Advanced Composites Technology Conference*. NASA CP-3294, Vol. 1, Part 2, 1995, pp. 649–679.
32. Hawley, A. V.: *Development of Stitched/RTM Primary Structures for Transport Aircraft*. NASA CR-191441, 1993.
33. Markus, A. M.: *Fabrication Processes, Analysis Methods, and Test Results for Stitched Composite Structures*. NASA CR-191599, 1994.
34. Hinrichs, S. C.; Kropp, Y.; and Jegley, D. C.: Analysis and Testing of Stitched/RFI Subcomponents. *Sixth NASA/DOD Advanced Composites Technology Conference*. NASA CP-3326, Vol. 1, Part 1, 1996, pp. 209–233.
35. Markus, A.; Thrash, P.; and Rohwer, K.: Progress in Manufacturing Large Primary Aircraft Structures Using the Stitching/RTM Process. *Third NASA Advanced Composites Technology Conference*. NASA CP-3178, Part 1, 1993, pp. 453–479.
36. Hinrichs, S.; Jegley, D. C.; and Wang, J. T.: Structural Analysis and Test of Stitched Composite Wing Box. *Sixth NASA/DOD Advanced Composites Technology Conference*. NASA CP-3326, Vol. 1, Part 1, 1996, pp. 279–309.
37. Wang, J. T.; Jegley, D. C.; Bush, H. G.; and Hinrichs, S. C.: *Correlation of Structural Analysis and Test Results for the McDonnell Douglas Stitched/RFI All-Composite Wing Stub Box*. NASA TM-110267, 1996.
38. Hawley, A. V.: Detail Design Development of a Transport Aircraft Composite Wing. *Sixth NASA/DOD Advanced Composites Technology Conference*. NASA CP-3326, Vol. 1, Part 1, 1996, pp. 131–154.
39. Thrash, P. J.; and Miller, J. I.: Design of a Stitching Machine for Transport Aircraft Composite Wings. *Sixth NASA/DOD Advanced Composites Technology Conference*. NASA CP-3326, Vol. 1, Part 1, 1996, pp. 191–208.
40. Miller, J. L.; and Thrash, P. J.: Fabrication, Assembly and Checkout of an Advanced Stitching Machine. *11th DOD/NASA/FAA Conference on Fibrous Composites in Structural Design—Seventh NASA ACT Conference*, Aug. 1996.
41. Drenth, S. E.; and Renieri, M. P.: Cover Panel and Substructure Design for a Full-Scale Composite Transport Wing. *11th DOD/NASA/FAA Conference on Fibrous Composites in Structural Design—Seventh NASA ACT Conference*, Aug. 1996.
42. Sutton, J. O.: A Proposed Method of Compliance to Damage Tolerance Requirements for Commercial Aircraft Composite Primary Wing Structure. *Sixth NASA/DOD Advanced Composites Technology Conference*, NASA CP-3326, Vol. 1, Part 1, 1996, pp. 155–189.

Table 1. ACT Contractors

<b>Contract No.</b>	<b>Contractor</b>	<b>Research Emphasis</b>
<b>ADVANCED MATERIALS AND PROCESSES</b>		
NAS1-18841	Dow Chemical Co.	Toughened thermosets, RTM systems
NAS1-18834	BASF	Powder coated tow, thermoplastics
NAS1-18883	University of Utah	Interphase technology
NAS1-18887	Hercules	Advanced fiber placement
NAS1-18899	Sikorsky	Therm-X tooling methods
NAS1-18858	University of Delaware	Ordered staple manufacturing methods
<b>MECHANICS OF MATERIALS AND STRUCTURES</b>		
NAS1-18833	University of Utah	Fracture mechanics, laminate failure mechanics
NAS1-18878	Stanford University	Damage tolerance sensitivity, durability
NAS1-18854	Cal-Davis University	Aeroelastic tailoring technology
<b>DESIGN &amp; MFG. DEVELOPMENT OF FUSELAGE PANELS</b>		
NAS1-18842	Northrop Corp.	Innovative designs, structural scaling, verification
NAS1-18889	The Boeing Company	Pressurized structures, ATP mfg., structural tests
<b>DEVELOPMENT OF TEXTILE COMPOSITE STRUCTURES</b>		
NAS1-18840	Rockwell International Corp.	Textile failure response, fracture and fatigue
NAS1-18888	Lockheed Martin Corp.	Textile frames, window belts and panels
NAS1-18884	Northrop Grumman Corp.	Cross-stiffened structures, woven/stitched panels
NAS1-18862	McDonnell Douglas Corp.	Stitched/RFI wing boxes for transport aircraft
NAS1-20546	McDonnell Douglas Corp.	Stitched/RFI semi-span and full-span wing boxes

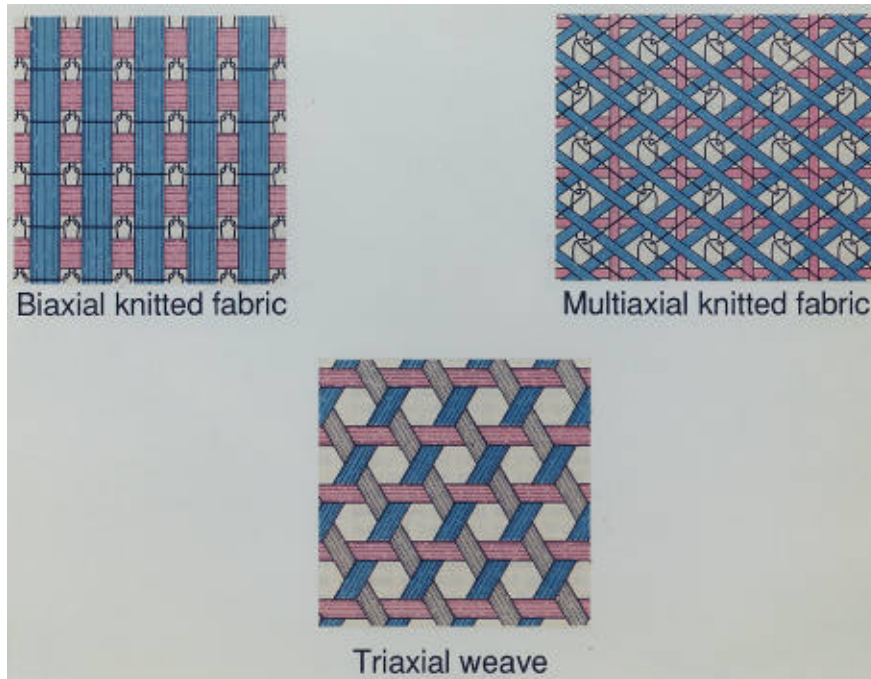


Figure 1. Carbon-epoxy upper aft rudder for DC-10 transport aircraft.



L-85-693

Figure 2. Elements of the Langley Research Center investigation of textile composite materials and structures.



L-89-7965

Figure 3. Advanced textile material forms—biaxial knit, multiaxial knit and triaxial weave.

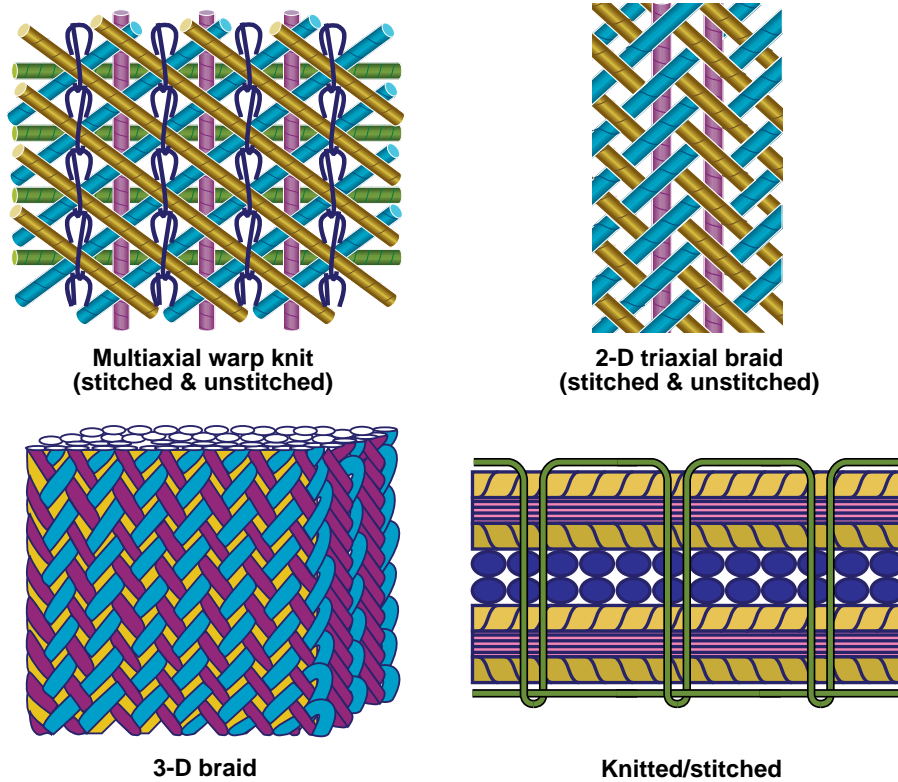


Figure 4. Advanced textile material forms—multiaxial warp knit, triaxial braid, three-dimensional braid and knitted stitched.

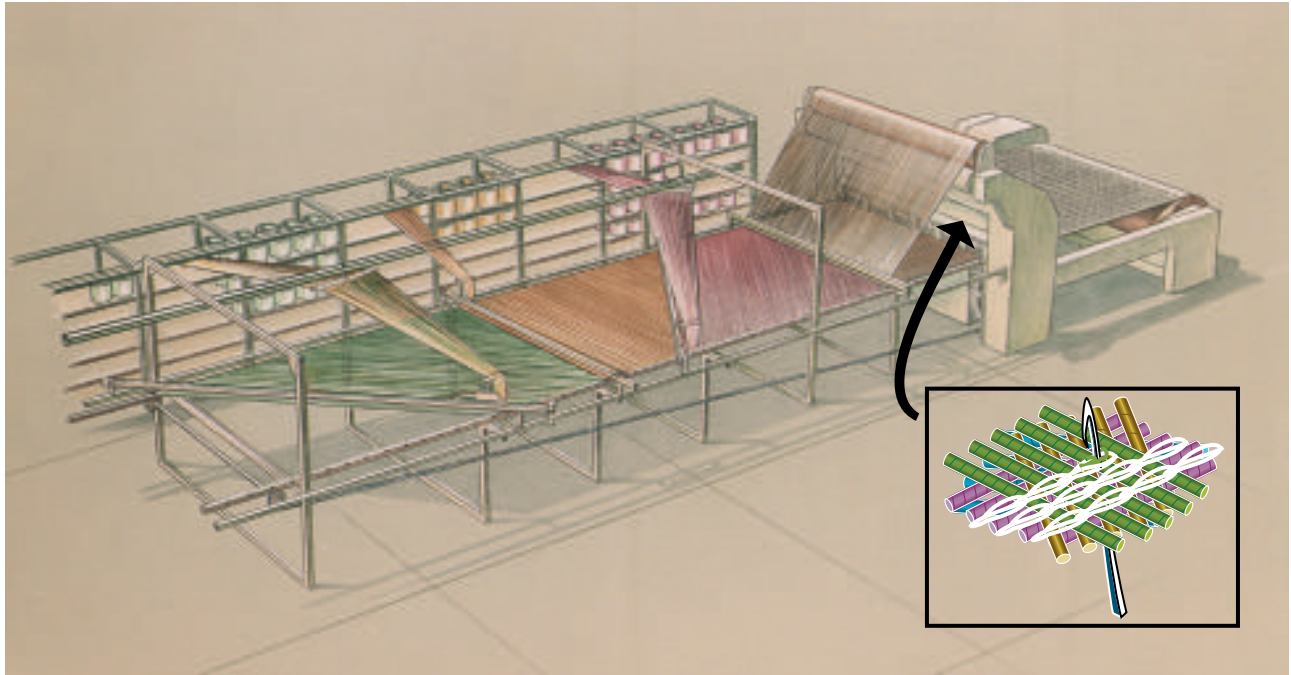


Figure 5. Schematic of multi-axial warp knitting machine.

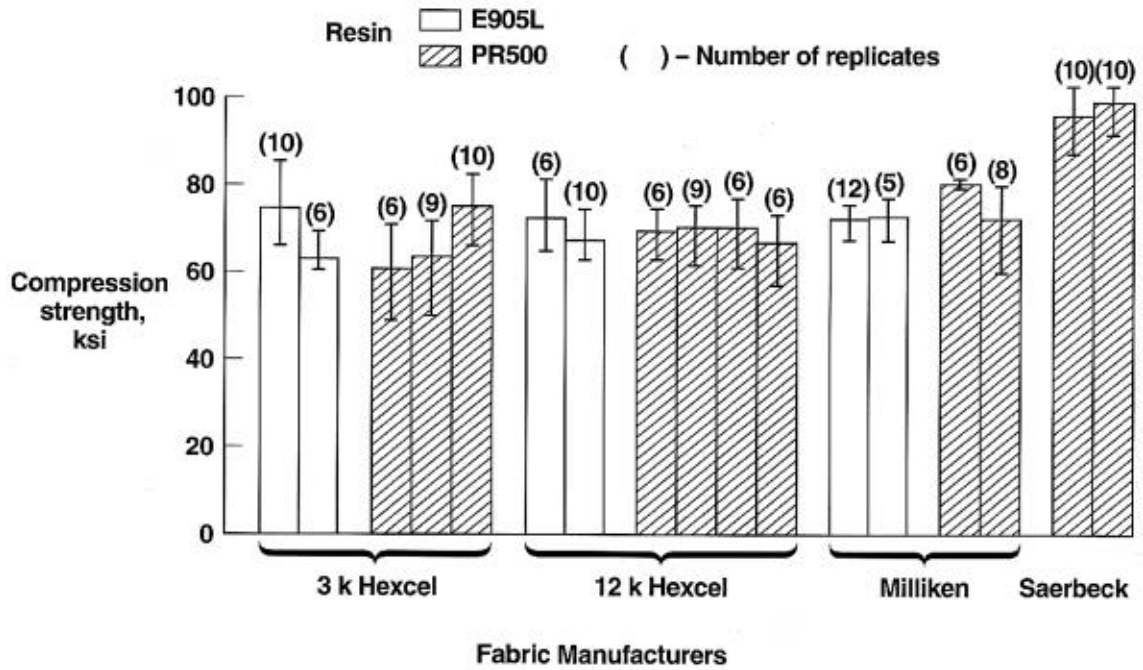


Figure 6. Compression strength data for composite laminates reinforced with multi-axial warp knit carbon tow preforms.

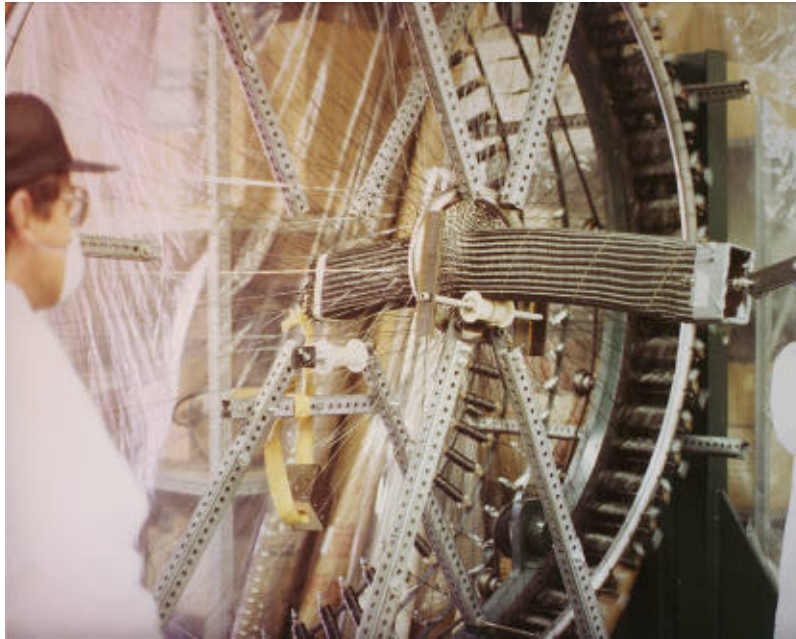


Figure 7. Photograph of a 2-D triaxial braiding machine (typ.).

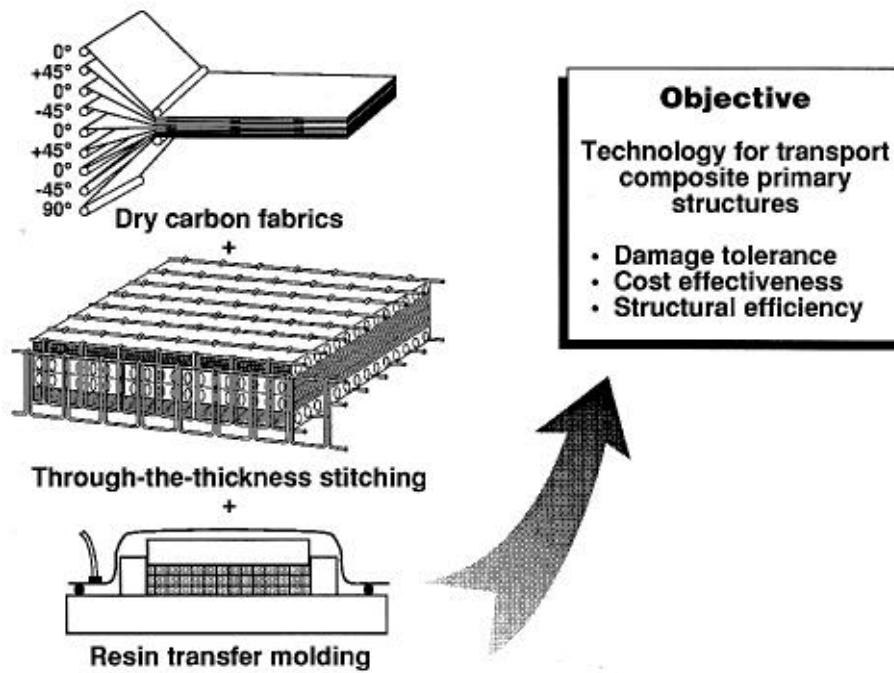


Figure 8. Schematic of process for making stitching-reinforced composites.

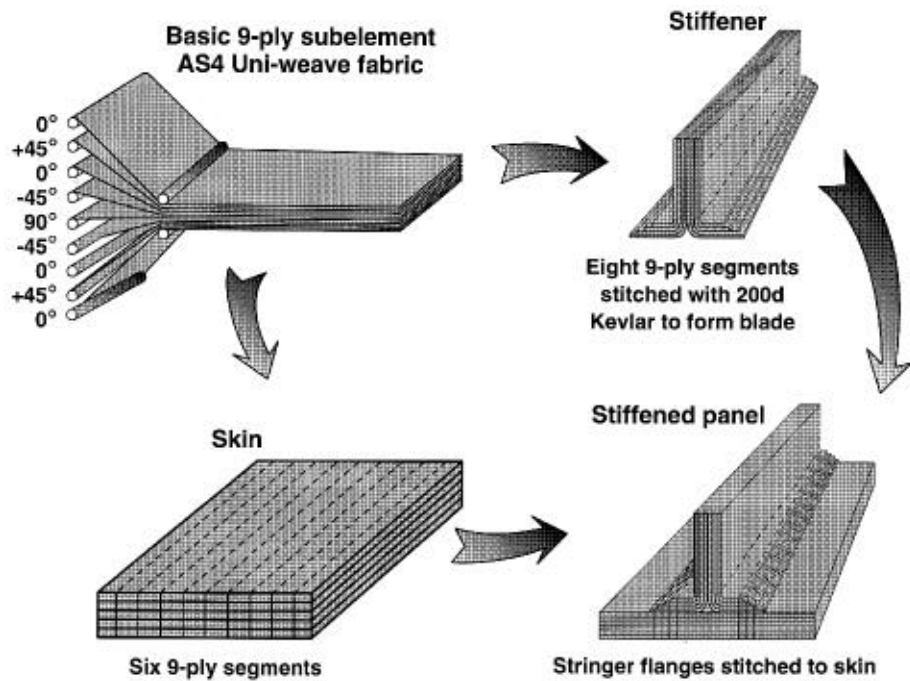


Figure 9. Process steps for making the stitched preform for a damage-tolerant stiffened panel.

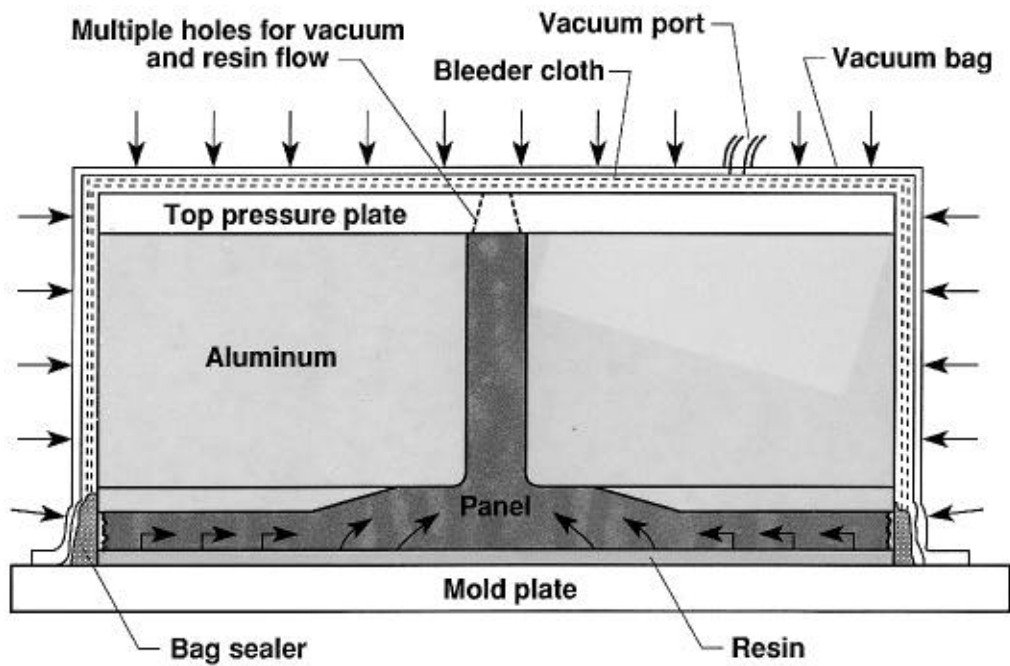


Figure 10. Schematic of resin film infusion (RFI) process.



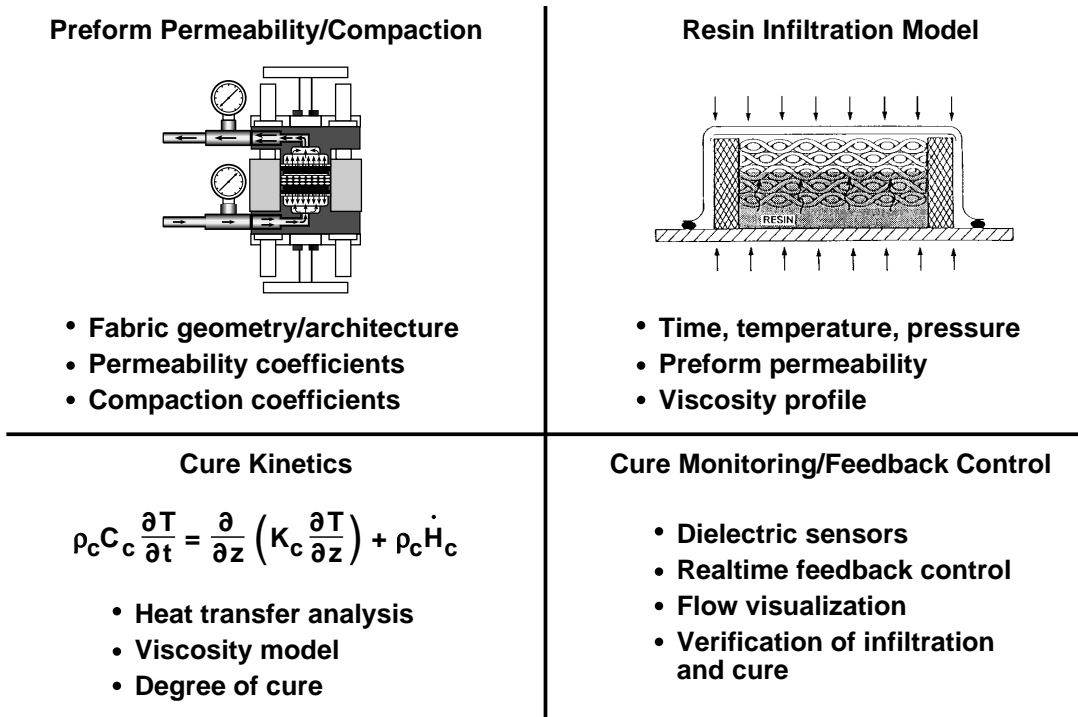


Figure 11. Elements of processing science for textile reinforced composites.

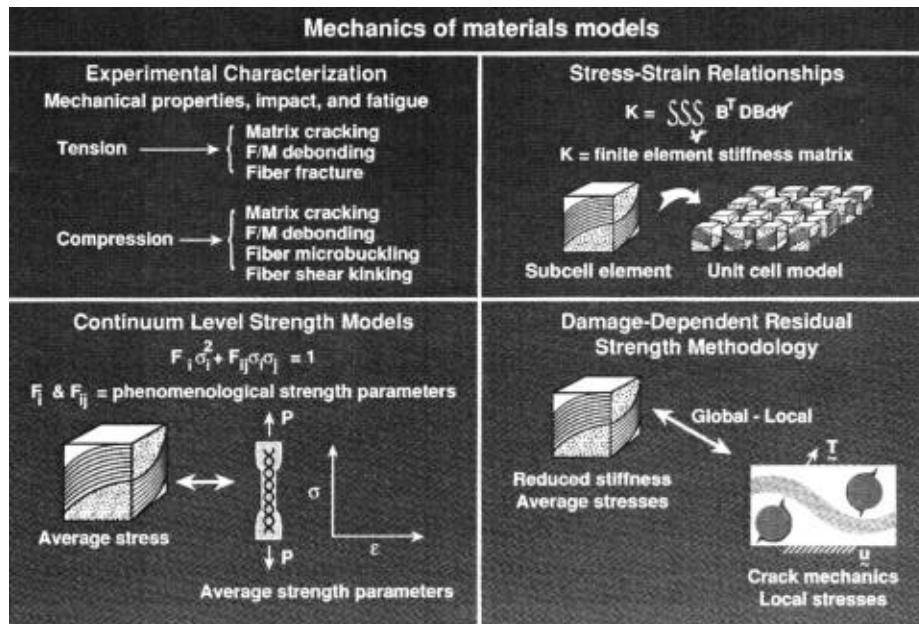


Figure 12. Elements of Langley mechanics of textile-reinforced-composite materials program.

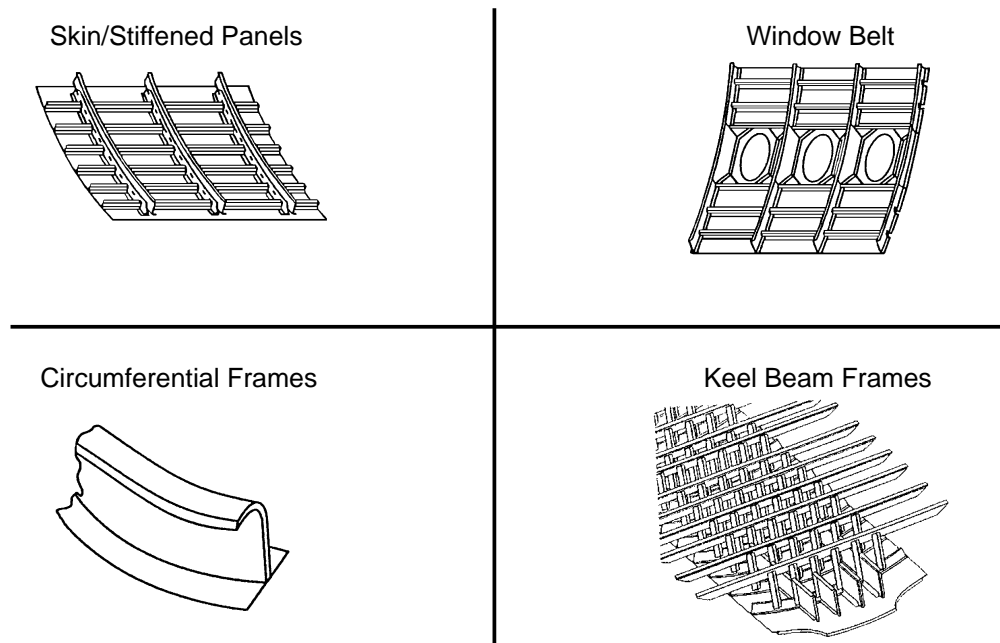


Figure 13. Application of textile reinforced composites in transport fuselage structures. (Lockheed Martin contract)



Figure 14. Three-dimensional integrally woven preform (epoxy-powder-coated tow) for a fuselage panel window belt component.



Figure 15. Completed fuselage panel window belt component.



Figure 16. Completed braided and woven window frames.

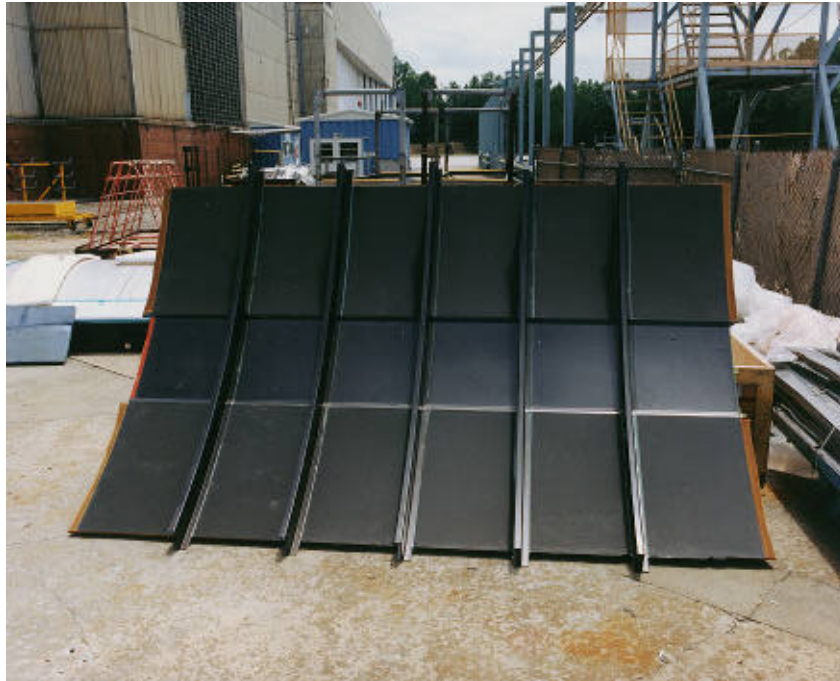


Figure 17a. Honeycomb-stiffened fuselage side panel with joggled braided frames.



Figure 17b. Honeycomb-stiffened fuselage side panel with constant-section braided frames.



L-90-859

Figure 18. Woven preform (carbon-PEEK tow) for a wing Y-spar. (Northrop Grumman contract)



Figure 19. Cross-stiffened fuselage window belt component.

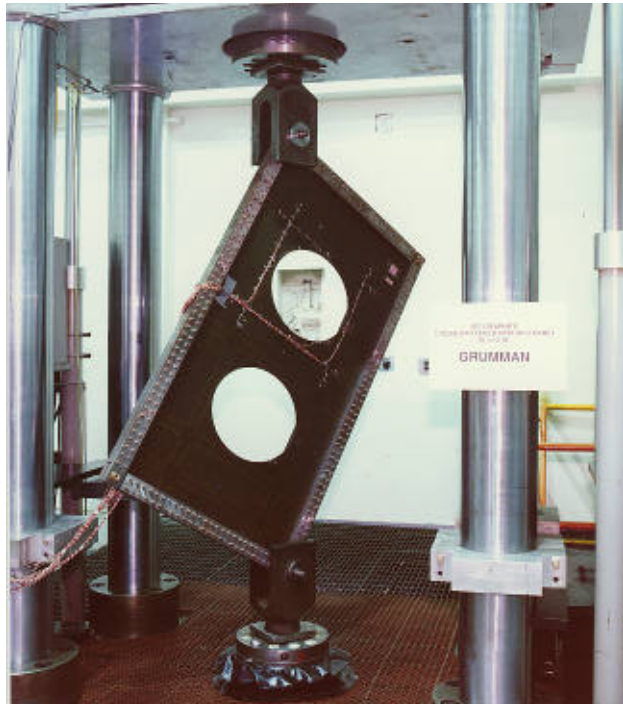


Figure 20. Picture frame shear test of cross-stiffened fuselage window belt component.

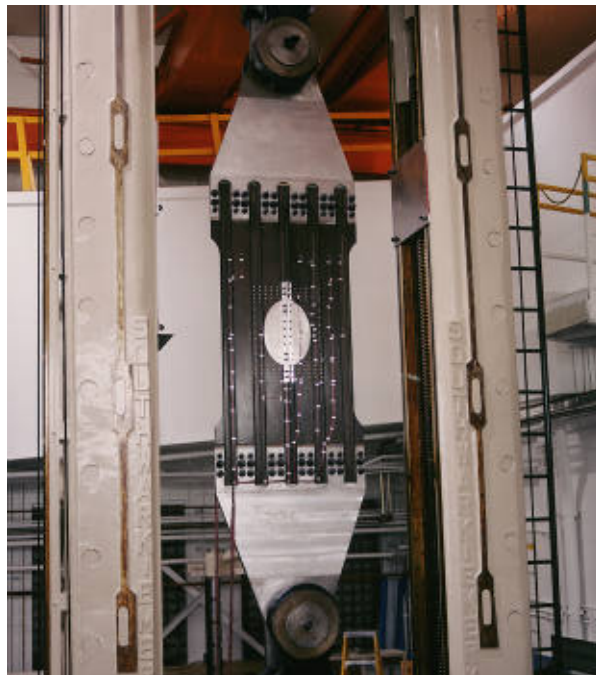


Figure 21. Cross-stiffened woven/stitched fuselage side panel.



L-94-02396

Figure 22a. Stitched/RFI wing panel in Langley 1,200-kip machine for discrete damage tolerance test.



L-95-03065

Figure 22b. Stitched/RFI wing panel in Langley 1,200-kip machine for damage repair test.



Figure 23. Stitched/RFI upper cover for wing stub box test component.



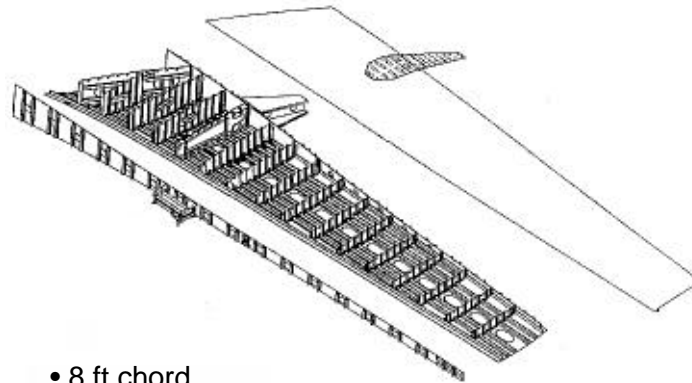
Figure 24. Assembly of wing stub box test component.





L-95-03782

Figure 25. Stitched/RFI wing stub box test set-up at the Langley Structures and Materials Laboratory.



- 8 ft chord
- 41 ft length
- 3 ft maximum depth
- Full scale, full loft definition
- All-composite construction
- Simulated engine pylon and landing gear

Figure 26. Design features of stitched/RFI semi-span wing.

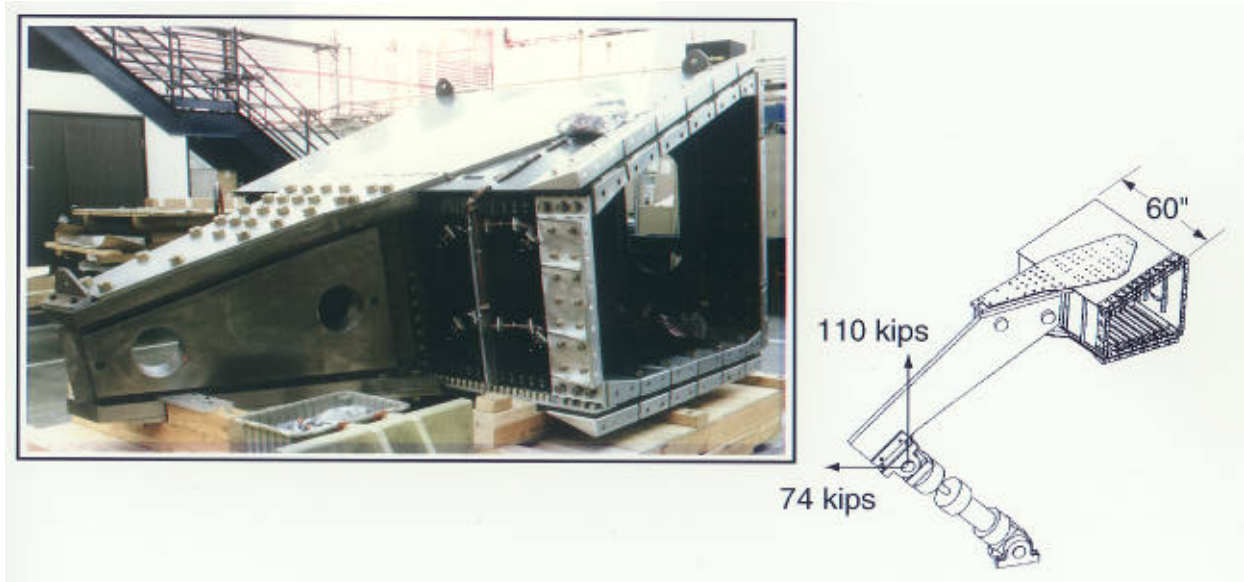


Figure 27. Main landing gear attachment test article for stitched/RFI wing.

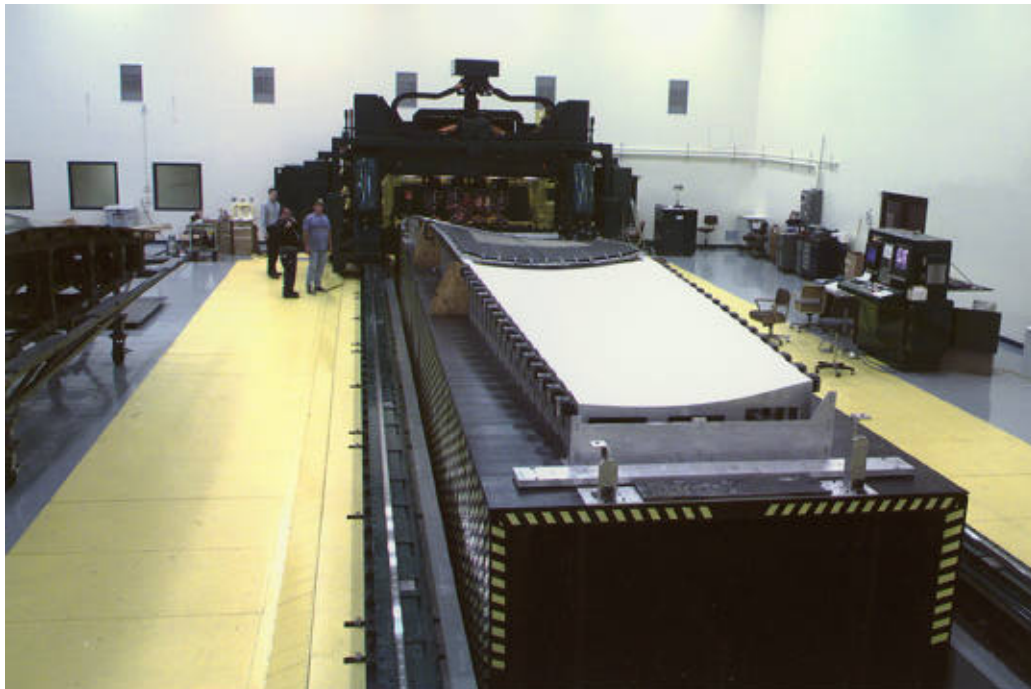


Figure 28. Advanced stitching machine at Huntington Beach Facility.

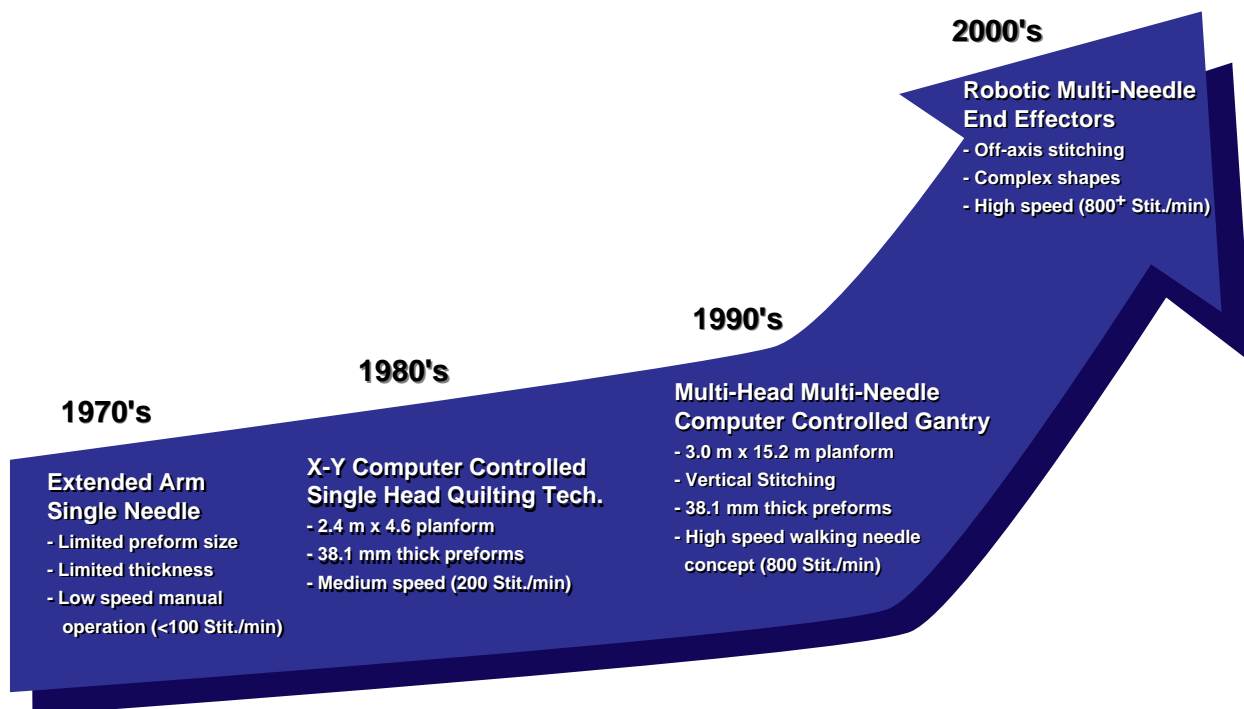


Figure 29. Expected evolution of composite stitching technology.

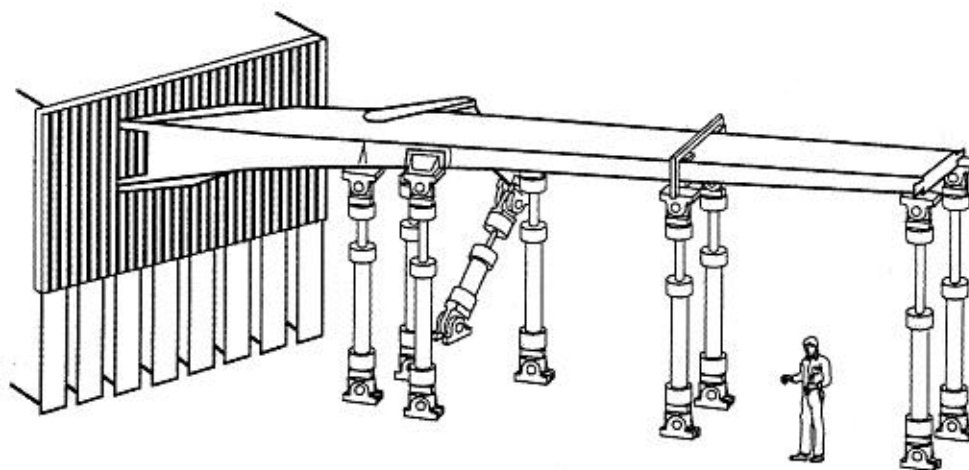


Figure 30. Schematic of stitched/RFI semi-span wing test set-up at the Langley Structures and Materials Laboratory.

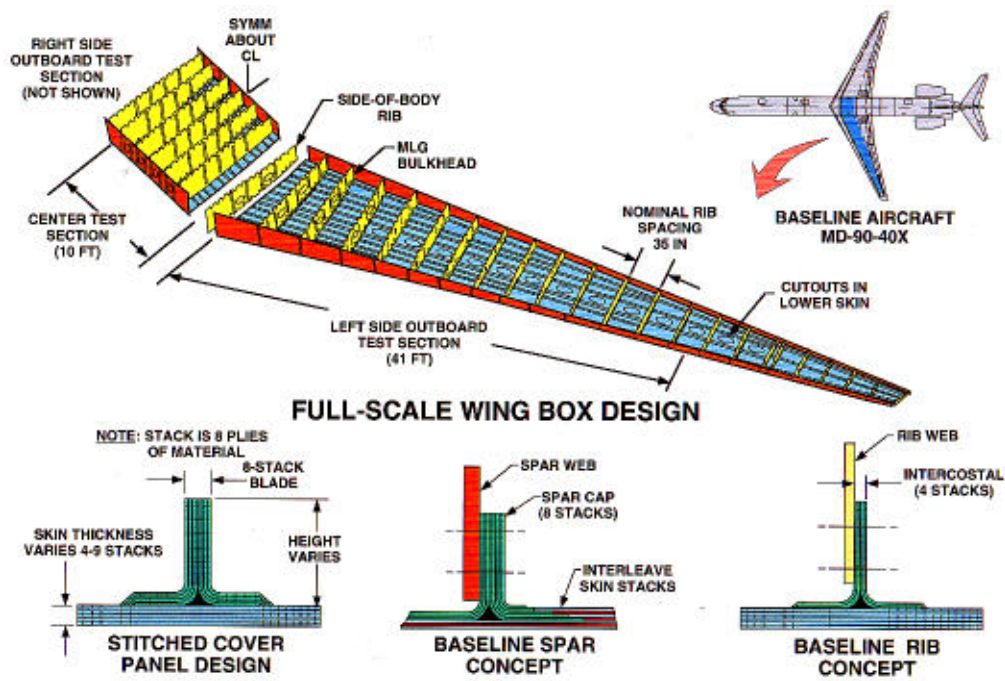


Figure 31. Design features of stitched/RFI full-scale wing.

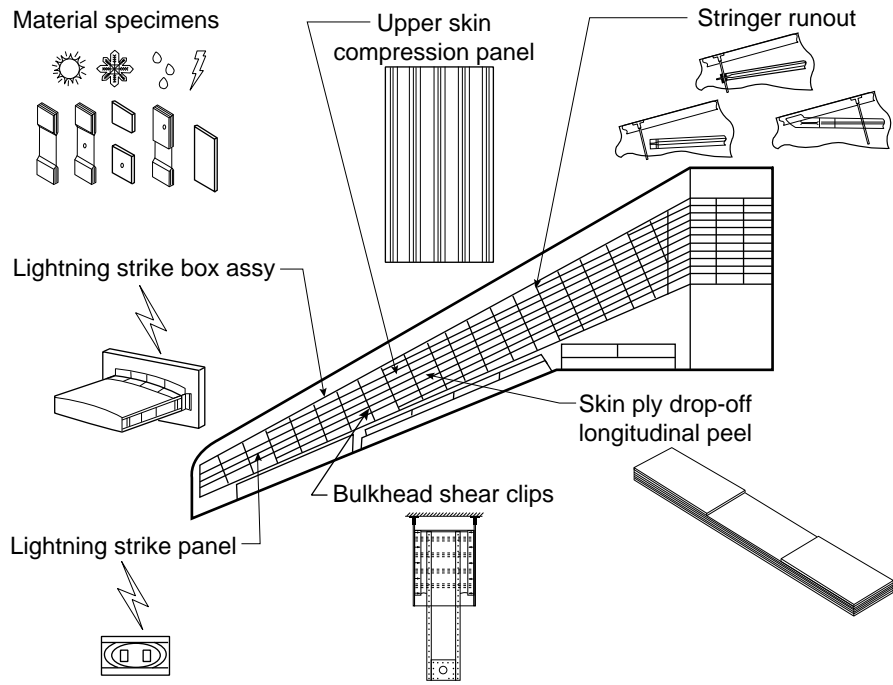


Figure 32a. Design development test articles for full-scale wing.

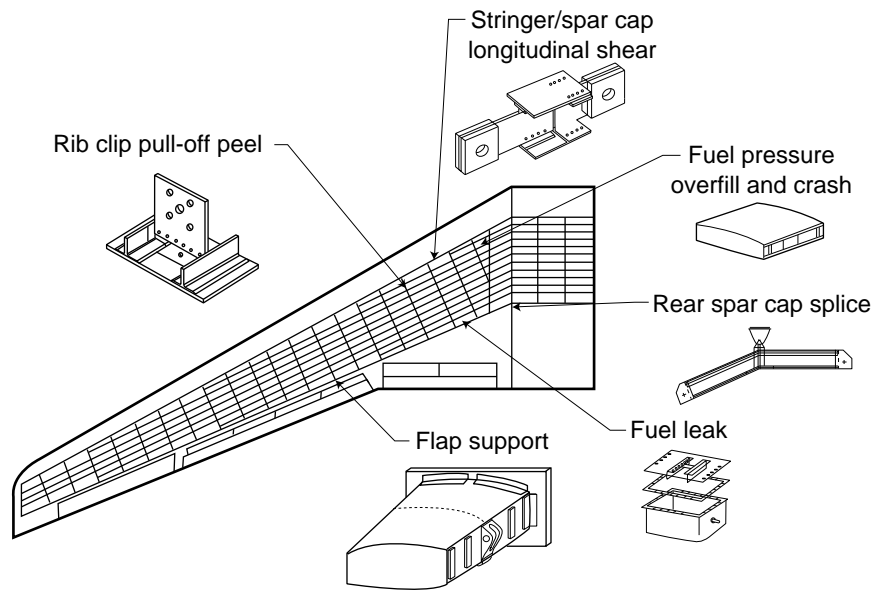


Figure 32b. Design development test articles for full-scale wing—concluded.

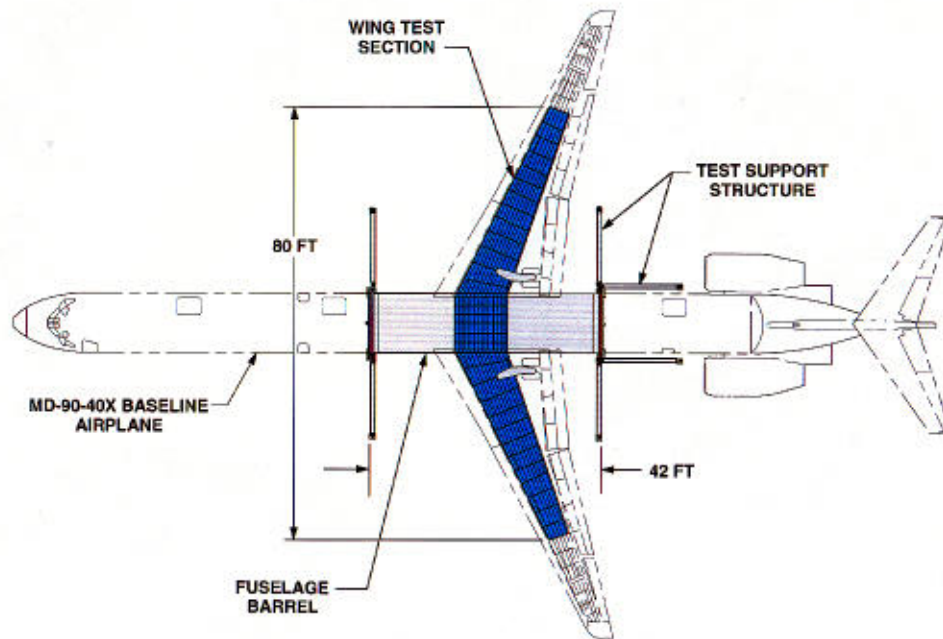


Figure 33. Full-scale wing test arrangement.

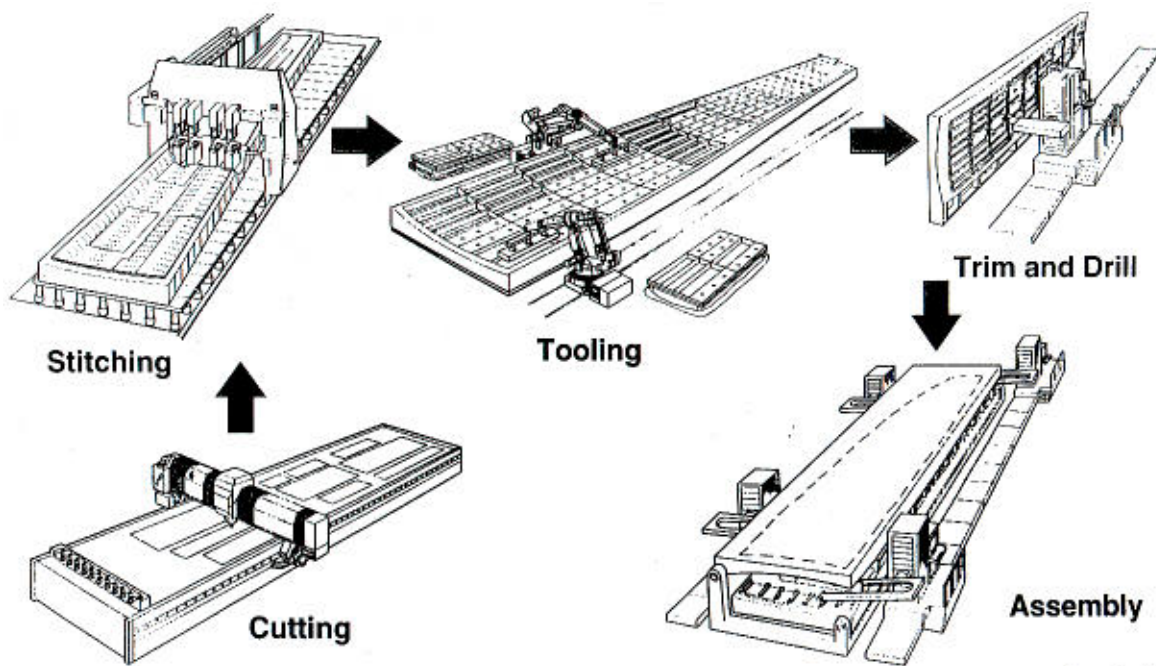


Figure 34. Factory-of-the-future concept for stitched/RFI wings.

## Appendix A

### Definition of Textile Terms

**Biaxial Braiding**—A two-dimensional fabric structure formed from two sets of tows interwoven symmetrically about an axis, one tow woven at an angle of  $+\Phi$  and the other set at an angle of  $-\Phi$ . The tows form a closed reinforcement. Braids can be flat like a doormat, tubular, or rectangular in cross section. Braids are susceptible to tow crimping which can reduce composite strength.

**Chain Stitching**—A class of stitching formed with one thread that has interlooping as a general characteristic. A stitch is formed by passing a loop of thread through the material and securing it by interlooping with succeeding loops, after they are passed through the material.

**Denier**—A term used to define thread size; it is the weight in grams of 9,000 meters of the thread.

**Fabric Crimp**—The angulation or distortion induced in a tow by the braiding or weaving process.

**Fill**—In a woven carbon fabric, the tows running at right angles to the warp or longitudinal tows.

**Knitting**—A method of constructing carbon fabric by interlocking series of loops of one or more tows.

**Lock Stitching**—A class of stitching formed with a heavy denier needle thread and a light denier bobbin thread that has interlacing as a general characteristic. Loops of the needle thread are passed through the material and secured by the bobbin thread to form a stitch. The stitch knots are pulled to the material surface by the bobbin thread to minimize the disturbance of the carbon tows.

**Loom**—A machine for weaving carbon fabric by interlacing a series of warp (longitudinal) tows with a series of fill (transverse) tows.

**Multiaxial Warp Knitting**—Fabrics made on special purpose machines consisting of linear warp ( $0^\circ$ ), fill ( $90^\circ$ ) and bias ( $\pm\Phi$ ) tows held together by a chain or tricot stitch through the thickness of the fabric. The load carrying tows are straight.

**Plain Weave**—One of the three fundamental weaves: plain, satin and twill. The plain weave is the simplest with one warp tow running over and under one fill tow. The plain weave is the most stable; it holds its shape and prevents tow slippage.

**Preform**—A pre-shaped fibrous reinforcement of carbon fabric incorporating various structural details and formed to the desired shape before being placed in tooling to be filled with resin.

**Resin Film Infusion (RFI)**—A fabrication process whereby epoxy resin films of measured thickness are placed in tooling, the preform is placed on the films, and the assemblage is bagged and cured in an autoclave.

**Resin Transfer Molding (RTM)**—A fabrication process whereby catalyzed epoxy resin is transferred or injected into a mold or tooling containing the preform.

**Stack**—An assemblage of unidirectional plies or layers of fabric that form a repeating element. Multiple stacks are stitched together to form the desired material thickness.

**Three-Dimensional Braiding**—A fabric structure formed by the continuous intertwining of tows. It is similar to two-dimensional braiding with the addition of a third set of tows that run in the longitudinal direction.

**Three-Dimensional Weaving**—A carbon fabric formation process used to produce three dimensional textile preforms. The tows are simultaneously woven in three directions (length, width and thickness) rather than in the conventional two directions. The fabric is formed of three basic components, axial, filling and weavers.

**Tow**—A large strand of continuous manufactured carbon filaments without definite twist, collected in a loose rope-like form. A tow typically contains 3, 6 or 12 thousand (3K, 6K OR 12K) filaments.

**Triaxial Weave**—Three tows are interwoven typically at  $60^\circ$  angles to one another in a single plane. Triaxial weaving is a type of two-dimensional weave that resists shearing and tearing.

**Tricot**—A generic term for the most common type of warp-knit fabric.

**Uniweave Fabric**—A type of plain weave fabric consisting of load bearing carbon tows in the warp direction with a small amount of glass thread (5 percent) in the fill direction which make it possible to handle the dry fabric.

**Warp Knitting**—A type of knitting in which the straight carbon warp tows run lengthwise and are locked in place by surrounding them with a skeleton of knit threads.

**Warp**—In a woven carbon fabric, the tows running at right angles to the fill or transverse tows.

## Appendix B

### Bibliography of Composites Reports

The technical publications listed herein (with their abstracts) were generated in the United States primarily in conjunction with the ACT Program, under the auspices of the Langley Research Center, and by other organizations. Within these three main categories, the documents are grouped into subsections according to subject matter and listed alphabetically by author. The

subsection titles, given in the “Contents” parallel the subject areas discussed in the text. An index by author is provided to increase the usefulness of this compilation.

License was taken to modify or shorten abstracts in the literature. Accession numbers, report numbers, and other identifying information are included in the citations to facilitate filling of requests for specific documents.

Availability sources of the different types of material are as follows:

#### Availability

Accession number	Type of material	Where obtained
00A00000 Example: 94A-25583	AIAA paper and published literature available from AIAA or in journals, conferences, etc., as indicated	American Institute of Aeronautics and Astronautics Technical Information Service 55 West 57th Street, 12th Floor New York, NY 10019
00N00000 Example: 94N-37604	Report literature having no distribution limitation	National Technical Information Service (NTIS) 5285 Port Royal Road Springfield, VA 22161

For Early Domestic Dissemination (FEDD) Restrictions—Because of its significant early commercial potential, information developed under a U.S. Government program is disseminated within the United States in

advance of general publication. Foreign release may be made only with prior NASA approval and appropriate export licenses. Abstracts under FEDD restrictions are identified with their dates for general release.



## Langley Textiles Research

### Braiding and Weaving Technology

1. Allen, L. E.; McCollum, J. R.; Edie, D. D.; and Lickfield, G. C.: Thermoplastic Coated Carbon Fibers for Textile Preforms. *Fiber-Tex 1988—Second Conference on Advanced Engineering Fibers and Textile Structures for Composites*, NASA CP-3038, 1989, pp. 367–373.

A novel process has been developed at Clemson University for prepreg formation using LARC-TPI, a thermoplastic polyimide created by NASA Langley Research Center. The prepreg formed by the process is highly flexible, does not require drying, and contains no major impurities. The flexibility of the material should allow it to be processed by weaving, braiding, and even knitting equipment.

2. Clarke, S.; and Morales, A.: A Comparative Assessment of Textile Preforming Techniques. *Fiber-Tex 1990—Fourth Conference on Advanced Engineering Fibers and Textile Structures for Composites*, NASA CP-3128, 1991, pp. 125–134.

An overview is given of textile preforming techniques suitable for the aerospace industry. Emphasis is placed on the several factors that must be considered to transition textile processing techniques from the laboratory to actual aerospace production.

3. Fedro, M. J.; and Willden, K.: Characterization and Manufacture of Braided Composites for Large Commercial Aircraft Structures. *Second NASA Advanced Composites Technology Conference*, NASA CP-3154, 1992, pp. 387–429.

Results are reported from a Boeing investigation of braided composite materials for fuselage structural components. The evaluation included 2-D braids, 3-D weaves, and 3-D braid patterns. Analytical methods were also developed and applied to predict material architectures and properties. Also, results are presented from the mechanics of materials work and the manufacturing demonstration.

4. Foley, M. F. and Bernardon, E.: Automation for the Manipulation of Flexible Materials. *Fiber-Tex 1990—Fourth Conference on Advanced Engineering Fibers and Textile Structures for Composites*, NASA CP-3128, 1991, pp. 97–110.

This paper presents a discussion of the relationship between the flexible materials manipulation task and the hardware required to perform the task. Automated systems developed to handle non-rigid materials are discussed as potential automation solutions for composite preforms. Finally, the paper emphasizes the importance of developing an appropriate control system.

5. Huey, C. O., Jr.; and Farley, G. L.: Development of Generalized 3-D Braiding Machines for Composite Preforms. *Fiber-Tex 1991—Fifth Conference on Advanced Engineering Fibers and Textile Structures for Composites*, NASA CP-3176, 1992, pp. 67–76.

Results are presented from the development of two prototype machines for the production of generalized 3-D braids. One prototype, the Farley braider, consists of an array of turntables that can be made to oscillate in 90 degree steps. The second machine, the shuttle plate braider, consists of a braiding surface formed by an array of stationary square sections.

6. Hugh, M. K.; Marchello, J. M.; Hartness, J. T.; Goodwin, S.; Shukla, J. G.; and Johnston, N. J.: Textile Composites from Powder-Coated Towpreg: Yarn Treatment for Braiding. *Moving Forward with 50 Years of Leadership in Advanced Materials—Proceedings of the 39th International Symposium and Exhibition*, Book 1, SAMPE, 1994, pp. 551–559.

Compression or autoclave molding of textile preforms made from polymer powder-coated yarns offers an alternative to resin transfer molding for the fabrication of net-shape parts. Results are reported from a study to establish a braiding protocol for powder-coated yarns by determining ways to maintain yarn integrity and to reduce tow-to-tow friction.

7. Hugh, M. K.; Marchello, J. M.; Maiden, J. R.; and Johnston, N. J.: Weavability of Dry Polymer Powder Prepreg. *Third NASA Advanced Composites Technology Conference*, NASA CP-3178, Part 1, Jan. 1993, pp. 175–189.

Results are presented from an investigation of carbon fiber yarns impregnated with thermoplastic polyimide powder. Parameters for weaving these yarns were established. Eight-harness satin fabrics were successfully woven from each of the three classes of yarns and consolidated into test specimens to determine mechanical properties. It was observed that for optimum results warp yarns should have flexural rigidities between 10,000 and 100,000 mg-cm. No apparent effect of tow size or twist was observed on either tension or compression modulus. However, fiber damage and processing costs favor the use of 12k yarn bundles in the weaving of powder-coated towpreg.

8. Kaufmann, J. R.: Industrial Applications of Multi-axial Warp Knit Composites. *Fiber-Tex 1991—Fifth Conference on Advanced Engineering Fibers and Textile Structures for Composites*, NASA CP-3176, 1992, pp. 77–86.

This paper examines the industrial applications of multi-axial warp knit fabrics. The paper contains a discussion of fabric properties.

**9.** Li, W.; Hammad, M.; and El-Shiekh, A.: Automation and Design Limitations of 3-D Braiding Processes. *Fiber-Tex 1989—Third Conference on Advanced Engineering Fibers and Textile Structures for Composites*, NASA CP-3082, 1990, pp. 115–140.

Results are reported from a study of the feasibility of automating the two-step and four-step 3-D braiding technologies. Two lab scale automatic machines, one for each process, have been designed, constructed and computer controlled. The results indicate that automation of both processes is feasible.

**10.** Mohamed, M. H.; and Zhang, Z.: Weaving of 3-D Preforms. *Fiber-Tex 1988—Second Conference on Advanced Engineering Fibers and Textile Structures for Composites*, NASA CP-3038, 1989, pp. 193–215.

This paper presents a review of 3-D weaving processes and discusses a process developed at North Carolina State University to weave 3-D multi-layer carbon fabrics. Also, discussed are the parameters which govern the physical properties of the composites. These parameters include fiber orientation, volume fraction and yarn density.

**11.** Morales, A.: Design and Cost Drivers in 2-D Braiding. *Fiber-Tex 1992—Sixth Conference on Advanced Engineering Fibers and Textile Structures for Composites*, NASA CP-3211, 1993, pp. 69–77.

This paper presents a description of the key cost drivers of 2-D braiding, i.e., part geometry, machine design, materials used, and operating parameters. Braiding is described as a highly efficient process for making continuous sleeving. However, this braiding approach shows little promise of reducing the cost of complex structural preforms.

**12.** Morales, A.; and Pastore, C.: Computer Aided Design Methodology for Three-Dimensional Woven Fabrics. *Fiber-Tex 1990—Fourth Conference on Advanced Engineering Fibers and Textile Structures for Composites*, NASA CP-3128, 1991, pp. 85–96.

This paper describes a computer aided design methodology for 3-D woven fabrics. With this design tool, the woven fabric can be designed directly on the computer screen where 3-D representations of the yarns within the fabric are transformed directly into weaving patterns. At the same time predictions are made for volume percent of each yarn type, fiber volume fraction, fabric thickness and yarn angles.

**13.** Rives, J. S.; and El-Shiekh, A.: Productivity in Manufacturing Preforms for Composites Part 1: The 3-D Braiding Process. *Materials Challenge Diversification and the Future—Proceedings of the 40th International Symposium and Exhibition*, Book 1, SAMPE, 1995, pp. 831–837.

Research reveals a direct correlation between productivity and preform design, machine size, and the number of fiber tows involved in braiding. The resulting data enable predictions of production time required for preform manufacturing.

**14.** Thaxton, C.; Reid, R.; and El-Shiekh, A.: Advances in 3-Dimensional Braiding. *Fiber-Tex 1991—Fifth Conference on Advanced Engineering Fibers and Textile Structures for Composites*, NASA CP-3176, 1992, pp. 43–65.

This paper presents an overview of the history of 3-D braiding and an in-depth survey of the most recent technological advances in machine design and implementation.

#### Test Methods for Textile Laminates

**15.** Fedro, M. J.; Coxon, B. R.; Einarson, M.; Poe, C. C., Jr.; Masters, J. E.; and Ifju, P. G.: Development of Mechanical Testing Guidelines for Textile Composites Targeted for Commercial Transport Applications. *Fourth NASA/DoD Advanced Composites Technology Conference*, NASA CP-3229, Part 2, 1993, pp. 757–771.

Results are presented from work-in-progress to develop test methods and procedures for 2-D and 3-D textile composites. In the experimental investigation, a 1,200 specimen test program was completed to develop testing procedures for tension, open-hole tension, compression, open-hole compression, and in-plane shear. Specimen instrumentation techniques were investigated.

**16.** Hartranft, D.; Pravizi-Majidi, A.; and Chou, T.-W.: Modeling and Characterization of Through-the-Thickness Properties of 3-D Woven Composites. *Mechanics of Textile Composites Conference*, NASA CP-3311, Part 2, 1995, pp. 251–313.

Results are reported from an investigation of the through-the-thickness properties of 3-D woven carbon/epoxy composites. For measuring these properties, the investigation aimed to establish test methods. Specimens were designed and tested for tensile, compressive and shear properties in the thickness direction. Measured elastic properties compared well with analytical predictions made using a volume averaging model.

**17.** Ifju, P. G.: Experimental Investigation of Textile Composite Materials Using Moir. *Mechanics of Textile*

*Composites Conference*, NASA CP-3311, Part 1, 1995, pp. 141–173.

Test methods for laminated composites may not be optimum for textile composites because the architecture of the textile induces nonuniform deformation characteristics. As a means to improve textile test methods, Moirated in studies conducted at the Langley Research Center to investigate the tensile behavior of 2-D braids and 3-D weaves. The results show that Moirated to document the surface strain on textile composites.

**18.** Masters, J. E.: *Compression Testing of Textile Composite Materials*. NASA CR-198285, 1996.

N96-21459

This report provides a review of efforts to establish a compression test method for textile reinforced composite materials. Experimental data were gathered from several sources and evaluated to assess the effectiveness of a variety of test methods. However, experimental results obtained by the Boeing Defense and Space Group for 2-D triaxially braided materials were used to establish the recommended test method and specimen dimensions.

**19.** Masters, J. E.: *Strain Gage Selection Criteria for Textile Composite Materials*. NASA CR-198286, 1996.

Results are reported from efforts to establish strain gage selection guidelines for textile reinforced composite laminates. Tension tests of a diverse collection of textile composite laminates were used to evaluate a variety of strain gages. Strain gages are recommended for braided, woven and stitched laminates.

**20.** Masters, J. E.; and Portanova, M. A.: *Standard Test Methods for Textile Composites*. NASA CR-4751, 1996.

Standard test methods are recommended for composite laminates reinforced with continuous networks of braided, woven, or stitched fibers. The recommended methods result from evaluations of testing methods currently used in the aerospace industry, and the current practices established by ASTM and the MIL-HDBK-17 Committee. Test methods are suggested for unnotched tension and compression, open-hole tension, filled-hole tension, open-hole compression, bolt bearing, and interlaminar tension.

**21.** Masters, J. E.; Ifju, P. G.; and Fedro, M. J.: Development of Test Methods for Textile Composites. *Fiber-Tex 1992—Sixth Conference on Advanced Engineering Fibers and Textile Structures for Composites*, NASA CP-3211, 1993, pp. 249–269.

Results are reported from research to establish a set of test methods for textile composites and, thus, help ensure accurate measurements of material properties. Initial research has concentrated on investigations of exist-

ing test methods. For application in aircraft laminates, a wide variety of 2-D and 3-D braided, woven, knit and stitched preforms have been studied.

**22.** Masters, J. E.; Ifju, P. G.; Pastore, C. M.; and Bogdanovich, A. E.: The Effects of Specimen Width on the Tensile Properties of Triaxially Braided Textile Composites. *Third NASA Advanced Composites Technology Conference*, NASA CP-3178, Part 2, 1993, pp. 523–536.

This study examined the effect of unit cell architecture on the mechanical response and tensile properties of 2-D triaxially braided composites. Based on test results from coupons of different widths, no width effect was observed on tensile properties for this braid architecture.

**23.** Minguet, P. J.; Fedro, M. J.; and Gunther, C. K.: *Test Methods for Textile Composites*. NASA CR-4609, 1994.

Various test methods commonly used for measuring the properties of tape laminate composites were evaluated to determine their suitability for measuring the properties of textile composites. Three types of textile composites were tested: 2-D triaxial braids, stitched uniweave fabric and 3-D interlock woven fabric. Ten categories of material properties were investigated: tension, open-hole tension, compression, open-hole compression, in-plane shear, filled-hole tension, bolt bearing, interlaminar tension, interlaminar shear and interlaminar fracture toughness. The report presents recommendations for test methods.

**24.** Portanova, M. A.: *Evaluation of the Impact Response of Textile Composites*. NASA CR-198265, 1995.

Results are reported from tests to measure the impact damage resistance and damage tolerance of laminates fabricated using stitched and unstitched uniweave fabric, 2-D braids, or 3-D weaves. All the laminates were subjected to either quasi-static indentation or falling weight impact and then tested in either tension or compression to measure residual strength.

**25.** Portanova, M. A.: *Standard Methods for Unnotched Tension Testing of Textile Composites*. NASA CR-198264, 1995.

The ACT Program funded research by the Boeing Defense & Space Group to investigate the effects of specimen size on test results from textile composite laminates. To determine the appropriate size and shape, tests were made using specimens covering a range of lengths, widths, and thicknesses. The results show that acceptable data will be obtained using the specimen configurations described in ASTM D3039.

26. Portanova, M. A.; and Masters, J. E.: *Standard Methods for Bolt Bearing Testing of Textile Composites*. NASA CR-198266, 1995.

Results are reported from an investigation of the applicability of existing bolt bearing specimen configurations to textile composite laminates. Most of the test data used were generated by the Boeing Defense & Space Group. The investigation found that the test methods have considerable influence on the data obtained in tests of braided composites. For guidance, investigators should consult MIL-HDBK-17.

27. Portanova, M. A.; and Masters, J. E.: *Standard Methods for Filled Hole Tension Testing of Textile Composites*. NASA CR-198262, 1995.

This paper presents the results of research to establish a standard filled-hole test method. Test results from independent studies performed by Lockheed Aeronautical Systems Co. and Boeing Defense & Space Group are compared and evaluated herein. The evaluation shows that existing methods for open hole tension tests (ASTM D5766) should provide adequate results.

28. Portanova, M. A.; and Masters, J. E.: *Standard Methods for Open Hole Tension Testing of Textile Composites*. NASA CR-198262, 1995.

The ACT Program funded research by the Boeing Defense & Space Group to investigate the effects of specimen geometry and loading on the measurement of mechanical properties in textile composite laminates. This paper presents the procedure and the recommendations of the Boeing work. Existing standard practices such as ASTM D5766 were determined to be adequate for textile composites.

29. Portanova, M.: Impact Testing of Textile Composite Materials. *Mechanics of Textile Composites Conference*, NASA CP-3311, Part 2, 1995, pp. 391–423.

N96-17710

Results are reported from an evaluation of the impact damage resistance and damage tolerance of a variety of textile composite materials. Static indentation and impact tests were performed on the stitched and unstitched uni-weave composites constructed from AS4/3501-6 carbon/epoxy. Compression and tension strengths were measured after the impacts to determine the damage resistance, residual strength and the damage tolerance of the specimens.

#### **Tests of Braided and Woven Laminates and Elements**

30. Burr, S. T.; and Morris, D. H.: Characterization of Two-Dimensionally Braided Composites Subject to

Static and Fatigue Loading. *Mechanics of Textile Composites Conference*, NASA CP-3311, Part 1, 1995, pp. 33–53.

Results are presented from a characterization of the damage processes in four different 2-D braids. Damage mechanisms in static compression testing were observed to range from matrix cracking to fiber bundle kinking and splitting. In static tension and tension-tension fatigue loading all laminates experienced bundle splitting followed by bundle disbonding from the matrices.

31. Deaton, J. W.; and Dexter, H. B.: Evaluation of Braided Stiffener Concepts for Transport Aircraft Wing Structure Applications. *Mechanics of Textile Composites Conference*, NASA CP-3311, Part 1, 1995, pp. 61–97.

Data are presented from compression tests of three-stiffener wide panels and from individual stiffener crippling tests. The tests determined the compressive behavior of three braided stiffener preform fabric constructions and of one stitched preform construction. Stiffener and panel fabrication are described and data are presented for specimens with and without impact damage.

32. Deaton, J. W.; Kullerd, S. M.; and Portanova, M. A.: Mechanical Characterization of 2-D, 2-D Stitched, and 3-D Braided/RTM Materials. *Third NASA Advanced Composites Technology Conference*, NASA CP-3178, Part 1, 1993, pp. 209–230.

N95-29038

Results are presented from a characterization of 2-D triaxial braid, 2-D triaxial braid plus stitching, and 3-D (through-the-thickness) braid composite materials. The braided preforms all had the same carbon tow size, the same braid architecture and were resin transfer molded using the same mold. Data include unnotched and notched compression and tension strengths, compression after impact, and tension and compression fatigue strengths for one resin/braid material.

33. Delbrey, J.: *Database of Mechanical Properties of Textile Composites*. NASA CR-4747, Aug. 1996.

The database contains results for about 3,500 coupon level tests, of ten different fiber/resin combinations, and seven different textile architectures such as braids, weaves and knits. Also, the database contains some prepreg tape composites data from NASA ACT contracts.

34. Dexter, H. B.; and Hasko, G. H.: Performance of Resin Transfer Molded Multiaxial Warp Knit Composites. *Third NASA Advanced Composites Technology Conference*, NASA CP-3178, Part 1, 1993, pp. 231–261.

Results are presented from NASA studies of resin transfer molding (RTM) and mechanical property

measurements of composites reinforced with three multi-axial warp knit fabrics. Test results presented include tension, open hole tension, compression, open hole compression, and compression after impact. Compared to prepreg tape laminates, the tension and compression strengths of the knitted fabrics were 30 percent lower, the open hole strengths were similar and the CAI strengths were 50 percent higher.

**35.** Dexter, H. B.; Hasko, G. H.; and Cano, R. J.: Characterization of Multiaxial Warp Knit Composites. *First NASA Advanced Composites Technology Conference*, NASA CP-3104, Part 1, 1991, pp. 589–619.

Results are presented from an investigation to characterize the mechanical behavior and damage tolerance of two multi-axial warp knit fabrics. Test results show that textile reinforced composites with through-the-thickness reinforcement have excellent damage tolerance compared to state-of-the-art laminated tape composites. The potential for significant cost savings for textile composites has increased aerospace interest in these materials.

**36.** Fedro, M. J.; Gunther, C.; and Ko, F. K.: Mechanical and Analytical Screening of Braided Composites for Transport Fuselage Applications. *First NASA Advanced Composites Technology Conference*, NASA CP-3104, Part 2, 1991, pp. 677–704.

This paper summarizes a mechanics of materials approach to predict the stiffness and strength of braided laminates for application in a transport fuselage. Composites consisting of both 2-D and 3-D braid patterns were investigated. Mechanical tests were made to obtain the following properties: unnotched tension, open hole tension, compression, compression after impact, in-plane shear, transverse shear, out-of-plane tension, bearing, and crippling.

**37.** Furrow, K. W.: *Material Property Evaluation of Braided and Braided/ Woven Wing Skin Blade Stiffeners*. NASA CR-198303, 1996.

Mechanical properties and processing characteristics of braided and braided/woven composites were evaluated and compared to warp knit composites to determine their suitability for wing cover blade stiffeners on the stitched/RFI wings being developed by McDonnell Douglas Aerospace. Three triaxial braids with angles of 53°, 60° and 70° were evaluated plus one 45° triaxial braid/plain weave combination. The results show that, for wing panel stiffeners, braided preforms offer an acceptable alternative to warp knit preforms.

**38.** Furrow, K. W.: Material Property Evaluation of Braided and Braided/ Woven Wing Skin Blade Stiffeners. *Sixth NASA/DoD Advanced Composites Technology*

*Conference*, NASA CP-3326, Vol. 1, Part 1, 1996, pp. 257–278.

Braided and braided/woven composites were evaluated to determine their suitability for use as composite wing panel stiffeners. Three triaxial braids with angles of 53°, 60° and 70° were evaluated plus one 45° triaxial braid/plain weave combination. The mechanical properties and processing characteristics were measured and compared to warp knit composites. The results show that, for wing panel stiffeners, braided preforms offer an acceptable alternative to warp knit preforms. FEDD restricted until June 30, 1998.

**39.** Hammad, M.; El-Messery, M.; and El-Shiekh, A.: Structural Mechanics of 3-D Braided Preforms for Composites. *How Concept Becomes Reality—Proceedings of the 36th International Symposium and Exhibition*, Book 1, SAMPE, 1991, pp. 114–128.

This paper presents the fundamentals of the 4-step 3-D tubular braiding process and the structure of the preforms produced. Based on an idealized structural model, geometric relations between the structural parameters of the preform are analytically established. The effects of machine arrangement and operating conditions are discussed.

**40.** Hardee, H. A.; Black, K.; Reid, R.; and El-Shiekh, A.: Flexural Properties of 2-D and 3-D Braided Carbon/Epoxy Composites. *Materials Challenge Diversification and the Future—Proceedings of the 40th International Symposium and Exhibition*, Book 1, SAMPE, 1995, pp. 821–830.

Data are reported from flexure tests of 2-D and 3-D braided laminates. The tests were conducted in accordance with ASTM D790.

**41.** Jackson, W. C.; and Portanova, M. A.: Impact Damage Resistance of Textile Composites. *Technology Transfer in a Global Community—Proceedings of the 28th International Technical Conference*, SAMPE, 1996, pp. 339–350.

This report summarizes the results from a series of tests made to characterize the impact resistance of a variety of textile composites including 2-D braids, 3-D weaves, and stitched and unstitched uniweave fabrics. Laminates were evaluated using a quasi-static indentation test method. The damage resistance was summarized in terms of the contact force required to initiate large delaminations and a delamination resistance parameter.

**42.** Jackson, W. C.; and Portanova, M. A.: Out-of-Plane Properties. *Mechanics of Textile Composites Conference*, NASA CP-3311, Part 2, 1995, pp. 315-348.

N96-17707

Results are reported from three experimental investigations to measure the out-of plane properties of textile composite materials. In the first investigation, tests were run on specimens made using 2-D braids, 2-D and 3-D weaves, and prepreg tapes. A new test method based on a curved beam was evaluated. In the second investigation, a new impact test method, based on quasi-static indentation, was verified which is able to directly measure damage resistance. In the third investigation, the new impact test method was used to measure the damage resistance of textile laminates.

**43.** Li, W.; Hammad, M.; and El-Shiekh, A.: Effect of Braiding Process on the Damage Tolerance of 3-D Braided Graphite/Epoxy Composites. *Tomorrows Materials: Today—Proceedings of the 34th International Symposium and Exhibition*, Book 2, SAMPE, 1989, pp. 2109–2117.

Results are reported from an experimental study of the effect of different processing methods on the damage tolerance of 3-D braided composite material. Test specimens were prepared from material braided by the 2-step and 4-step process. Material made with the 2-step process was observed to have the better damage tolerance.

**44.** Li, W.; Hammad, M.; Reid, R.; and El-Shiekh, A.: Bearing Behavior of Holes Formed Using Different Methods in 3-D Graphite/Epoxy Composites. *Advanced Materials: The Challenge for the Next Decade—Proceedings of the 35th International Symposium and Exhibition*, Book 2, SAMPE, 1990, pp. 1638–1646.

Results are presented from bolt bearing tests of braided composites with holes formed by three different methods. The three methods were: (1) cutting or drilling the hole after consolidation, (2) opening the hole by inserting pins during impregnation, and (3) directly braiding the hole into the preform. The braided holes gave the best bearing performance.

**45.** Masters, J. E.; Fedro, M. J.; and Ifju, P. G.: Experimental and Analytical Characterization of Triaxially Braided Textile Composites. *Third NASA Advanced Composites Technology Conference*, NASA CP-3178, Part 1, 1993, pp. 263–284.

Results are presented from a NASA and Boeing experimental and analytical investigation of triaxially braided textile composite materials. Experimental data presented include longitudinal and transverse tensile moduli, Poisson's ratio, and strengths. The analytical portion of the investigation utilized the Textile Composites Analysis (TECA) model to predict modulus and strength. The TECA model was accurate in modeling both the moduli and strengths of the braided composites.

**46.** Masters, J. E.; Foye, R. L.; Pastore, C. M.; and Gowayed, Y. A.: Mechanical Properties of Triaxially Braided Composites: Experimental and Analytical Results. *Ninth DoD/NASA/FAA Conference on Fibrous Composites in Structural Design—Second NASA ACT Conference*, FAA Report DOT/FAA/CT-92-25, I, pp. 99–124.

Results are reported from an experimental and analytical investigation of the unnotched tensile properties of 2-D triaxial braid reinforced composites. Three reinforcing architectures were investigated. Experimental strains correlated reasonably well with analytical predictions in the fiber direction but not in the transverse direction. Tensile strengths were generally unpredictable.

**47.** Masters, J. E.; Naik, R. A.; and Minguet, P. J.: Effects of Preform Architecture on Modulus and Strength of 2-D Triaxially Braided Textile Composites. *Mechanics of Textile Composites Conference*, NASA CP-3311, Part 2, 1995, pp. 349–378.

Results are reported from an experimental investigation of how braid yarn size, braid angle and axial yarn content influence the properties of braided textile composites. Experimental data are compared with predictions obtained from a TEXCAD program which successfully predicted mechanical properties.

**48.** Minguet, P. J.: A Comparison of Graphite/Epoxy Tape Laminates and 2-D Braided Composites Mechanical Properties. *Mechanics of Textile Composites Conference*, NASA CP-3311, Part 2, 1995, pp. 379–390.

In this paper the mechanical properties of tape laminates are compared to those of a 2-D triaxial braided composite laminate. The results are: longitudinal moduli are similar, tapes are stiffer in the transverse direction, the tapes are stronger in the unnotched form, in compression, all the braid properties are lower than those of tape laminates.

**49.** Norman, T. L.; and Anglin, C.: Tension Strength, Failure Prediction and Damage Mechanisms in 2-D Triaxial Braided Composites with Notch. *Mechanics of Textile Composites Conference*, NASA CP-3311, Part 1, 1995, pp. 131–140.

The unnotched and notched (open hole) tensile strength and failure mechanisms of 2-D triaxial braided composites were examined. Theory developed to predict the normal stress distribution near an open hole and failure for a tape laminate was evaluated for its applicability to the braided composites.

**50.** Poe, C. C., Jr.; Portanova, M. A.; Masters, J. E.; Sankar, B. V.; and Jackson, W. C.: Comparison of Impact Results for Several Polymeric Composites Over a Wide Range of Low Impact Velocities. *First NASA Advanced*

*Composites Technology Conference*, NASA CP-3104, Part 2, 1991, pp. 513–547.

Results are reported from residual strength tests of clamped composite plates subjected to static indentation, falling weight, or ballistic impact. The plates were made of AS4/3501-6 or IM7/8551-7. In addition, results are reported from pendulum and ballistic impact tests conducted on simply supported plates braided with Celion 12000. No significant differences were observed in the test data from clamped plates made using different fiber/resin combinations. Strength loss as a fraction of the undamaged strength was least for the braided laminate.

**51.** Portanova, M. A.: Impact Damage Tolerance of Textile Composites. *Technology Transfer in a Global Community—Proceedings of the 28th International Technical Conference*, SAMPE, 1996, pp. 351–362.

Results are presented from tests to characterize how textile composites respond to impact damage. Stitched and non-stitched uniweave fabrics, 2-D braids and 3-D weaves were evaluated. Damage tolerance was determined as the ratio of damaged to undamaged strength.

**52.** Smith, D. L.; and Dexter, H. B.: Woven Fabric Composites with Improved Fracture Toughness and Damage Tolerance. *Fiber-Tex 1988—Second Conference on Advanced Engineering Fibers and Textile Structures for Composites*, NASA CP-3038, 1989, pp. 75–89.

Results are reported from an investigation of a new woven fabric (Thornel T300) designed with interlocking plies and fabricated as a composite with a toughened resin system (Hercules 8551-7). Mechanical property testing was performed on the composite laminate to measure tension and compression strengths, and damage tolerance and interlaminar fracture toughness. Strength values were less than from conventional composite laminates but damage tolerance values were much better.

**53.** Swanson, S. R.; and Smith, L. V.: Multiaxial Stiffness and Strength Characterization of 2-D Braid Carbon/Epoxy Fiber Composites. *Mechanics of Textile Composites Conference*, NASA CP-3311, Part 1, 1995, pp. 175–249.

Results are reported from a comprehensive study of the stiffness and strength properties of 2-D braids. Tubular specimens made with the RTM process were used in the testing program. The biaxial loadings involved both compression-compression and tension-tension tests.

#### Tests of Stitched Laminates and Elements

**54.** Ambur, D. R.; and Dexter, H. B.: Structural Performance of a Compressively Loaded Foam-Core Hat-Stiffened Textile Composite Panel. *37th AIAA Structures*,

*Structural Dynamics and Materials Conference*, 1996. Available as AIAA Paper 96-1368.

A96-30767

Results are reported from tests of a hat-stiffened panel made with textile composite skins and stiffened with hats filled with structural foam. This foam-filled hat-stiffener concept is structurally more efficient than most other prismatically stiffened panel configurations in a load range that is typical for both fuselage and wing structures. Buckling and postbuckling behavior of the panel was determined with and without low-speed impact damage. The results showed the panel responds to loading as expected and that it has excellent damage tolerance characteristics compared to a similar panel constructed from prepregged graphite-epoxy tape material.

**55.** Cano, R. J.; and Furrow, K. W.: Effects of Temperature and Humidity Cycling on the Strengths of Textile Reinforced Carbon/Epoxy Composite Materials. *Third NASA Advanced Composites Technology Conference*, NASA CP-3178, Part 1, 1993, pp. 191–208.

N95-29037

Results are presented from an experimental evaluation of the combined effects of temperature and humidity cycling on AS4/3501-6 laminates (unstitched, stitched and braided). Data presented include compression strengths and compression-compression fatigue results for uncycled composites and cycled composites (160, 480, 720, and 1280 cycles from 140°F at 95 percent relative humidity to –67°F).

**56.** Deaton, J. W.; Kullerd, S. M.; Madan, R. C.; and Chen, V. L.: Test and Analysis Results for Composite Transport Fuselage and Wing Structures. *Second NASA Advanced Composites Technology Conference*, NASA CP-3154, 1992, pp. 169–193.

N94-33129

Data are presented from tests to assess the damage tolerance of automated tow placement (ATP) fuselage elements and stitched/RTM fuselage elements with stitched-on stiffeners. Also, data are presented to assess the damage tolerance of wing elements made using the stitched/RTM process for skin and stiffeners. The stitched fuselage elements demonstrated superior stiffener-to-skin integrity in stiffener pull-off tests. They were two times stronger than ATP elements without damage and ten times stronger than ATP elements with damage. Stitched/RTM wing panels met design load requirements after 100 ft-lb impacts at critical locations.

**57.** Dexter, H. B.; and Funk, J. G.: Impact Resistance and Interlaminar Fracture Toughness of Through-the-Thickness Reinforced Graphite/Epoxy. *27th AIAA*

A86-38877

Five through-the-thickness stitch configurations were analyzed to determine the effect of stitching on the impact resistance and interlaminar fracture toughness of T300/3501-6 graphite/epoxy laminates. The test specimens were stitched in various patterns using either polyester or Kevlar yarns. It was observed that the stitched laminates had tension and compression strengths 20–25 percent lower than the strengths of unstitched laminates. The impact data revealed that the Kevlar stitched laminates have less damage than unstitched laminates. The mode I critical strain energy release rate for the Kevlar stitched laminate was calculated as 30 times higher than that of the unstitched laminate.

**58.** Dickinson, L. C.: A Designed Experiment in Stitched/RTM Composites. *Third NASA Advanced Composites Technology Conference, NASA CP-3178, Vol. 1, Part 1, 1993, pp. 381–397.*

N95-29046

Results are reported from a statistically designed experiment (a fractional factorial, also known as a Taguchi L16 test matrix) used to evaluate five important parameters in stitched/RTM composites. The effects and interactions of stitch thread material, stitch thread strength, stitch row spacing and stitch pitch are examined for both thick (48 ply) and thin (16 ply) laminates.

**59.** Dickinson, L. C.: Effects of Stitching Parameters on Mechanical Properties and Damage Tolerance of Stitched/RTM Composites. *Fourth NASA Advanced Composites Technology Conference, NASA CP-3229, Vol. 1, Part 1, 1993, pp. 379–407.*

A statistically designed experiment was used to evaluate the strength effects and interactions of five stitching parameters. Stitch thread material, stitch thread breaking strength, stitch row density, stitch pitch were examined for both thick (48-ply) and thin (16-ply) carbon-epoxy laminates. Stitching was found to significantly improve laminate compression-after-impact strength but it decreased in-plane tension and compression strength. The results show that trade-offs must be made between in-plane strengths and damage tolerance to meet specific design requirements.

**60.** Dow, M. B.; and Smith, D. L.: Damage-Tolerant Composite Materials Produced by Stitching Carbon Fibers. *Advanced Materials: The Big Payoff—21st International Technical Conference, SAMPE, 1989, pp. 595–605.*

Results are reported from an experimental evaluation of composites tailored for damage tolerance by stitching layers of dry carbon-fiber fabric with closely-spaced threads, in order to furnish through-the-thickness reinforcement. With flat plate specimens, various stitching patterns and thread materials were evaluated and blade-stiffened panel elements were fabricated and tested. The results indicate that stitched laminates made using 3501-6 epoxy resin have damage tolerance performance comparable to that of more expensive, toughened-matrix composites. A90-33116

**61.** Dow, M. B.; Smith, D. L.; and Lubowinski, S. J.: An Evaluation of Stitching Concepts for Damage-Tolerant Composites. *Fiber-Tex 1988—Second Conference on Advanced Engineering Fibers and Textile Structures for Composites, NASA CP-3038, 1989, pp. 53–73.*

Results are presented from a Langley investigation of stitching combined with resin impregnation molding for both improved damage tolerance and economical fabrication. Composite laminates were tailored for damage tolerance by stitching layers of dry carbon fabric with various arrays of closely spaced threads to provide through-the-thickness reinforcement. Epoxy resin was infused into the preforms and cured to complete the processing. Compression strength, damage tolerance and constant amplitude fatigue data are reported.

**62.** Falcone, A.; and Dow, M. B.: The Effects of Aircraft Fuel and Fluids on the Strength Properties of Resin Transfer Molded (RTM) Composites. *Third NASA Advanced Composites Technology Conference, NASA CP-3178, Part 1, 1993, pp. 399–413.*

Results are presented from fluids exposure tests of four carbon/epoxy composites and one carbon/bismaleimide composite. The strongest material tested was AS4/3501-6 and that material was used as a measure of merit in evaluating the other matrix resins. As expected, all the matrix resins suffered severe strength degradation from exposure to paint stripper. In terms of the percentage strength reductions, all of the RTM resins compared favorably with 3501-6 epoxy.

**63.** Farley, G. L.: A Mechanism Responsible for Reducing Compression Strength of Through-the-Thickness Reinforced Composite Material. *J. Compos. Mater.*, vol. 26, no. 12, 1992, pp. 1784–1795.

A92-56521

Thick (0°/90°) laminates with stitched and integrally woven reinforcements were fabricated and statically tested. In both the stitching and weaving processes, a surface loop of reinforcement yarn is created between successive penetrations. The surface loop of the reinforcement 'kinked' the in-plane carbon fibers and



reduced their effectiveness in carrying compressive load. Machining off the surface loop and 'kinked' in-plane fibers improved the strength between 7 and 35 percent.

**64.** Farley, G. L.; Smith, B. T.; and Maiden, J. L.: Compression Response of Thick Layer Composite Laminates with Through-the-Thickness Reinforcement. *J. Reinf. Plast. & Compos.*, vol. 11, no. 7, July 1992, pp. 787–810.

A92-47217

Results are reported from compression and compression-after-impact (CAI) tests conducted on seven different composite laminates. Four of the seven laminates had through-the-thickness reinforcement, i.e., stitching or integral weaving made from Kevlar or carbon thread. The three laminates without reinforcements were tested to establish a baseline for comparison purposes. The compression strengths of the reinforced laminates were approximately one half those of the baseline laminates. However, the CAI strengths of the reinforced materials were approximately twice those of materials without reinforcements.

**65.** Funk, J. G.; and Dexter, H. B.: Experimental Evaluation of Stitched Graphite/Epoxy Composites. *3-D Composite Materials—NASA/Navy Working-Group*, NASA CP-2420, 1986, pp. 185–205.

Data are presented from tests of composite laminates with stitching in the through-the-thickness direction. Tension and compression tests were made to determine the effects of stitching on strength properties of the laminates. Residual strength after impact, open hole compression strength and interlaminar fracture strength were measured to assess the damage tolerance and delamination resistance of the stitched laminates. The test results indicate that stitching is an effective means to increase the damage tolerance of otherwise easily damaged laminates.

**66.** Furrow, K. W.; Loos, A. C.; Dexter, H. B.; and Cano, R. J.: *Environmental Effects on Stitched/RTM Composites*. NASA CR-193221.

N93-29107

Results are reported from an investigation of the effects of temperature and humidity cycling on the mechanical properties of AS4/3501-6 quasi-isotropic textile composites. Resin transfer molded composites were made from unstitched, Kevlar 29 stitched, and S-2 glass stitched uniweave carbon fabric preforms. Temperature cycling ranged from 60 to  $-55^{\circ}$  C while the relative humidity simultaneously varied between 95 and 0 percent. Data presented include photomicrographs, compression strengths, and compression-compression fatigue results for environmentally cycled and uncycled composites.

**67.** Kullerd, S. M.: The Combined Effect of Glass Buffer Strips and Stitching on the Damage Tolerance of Composites. *Third NASA Advanced Composites Technology Conference*, NASA CP-3178, Part 1, 1993, pp. 433–451.

Results are presented from an investigation of the damage tolerance characteristics of composite laminates containing stitching and glass buffer strips. The interim findings are that buffer strip laminates have good damage tolerance; buffer strip laminates have acceptable open-hole compression strength which is unaffected by stitching; laminates with buffer strips have marginal open hole tension strengths which are unaffected by stitching; and strengths are not improved by careful alignment of the buffer strips. N95-29049

**68.** Kullerd, S. M.; and Dow, M. B.: Development of Stitched/RTM Composite Primary Structures. *Ninth DoD/NASA/FAA Conference on Fibrous Composites in Structural Design—Second NASA ACT Conference*, FAA Report DOT/FAA/CT-92-25.II, pp. 689–713 (Available in NASA CP-3154, June 1992, pp. 115–139).

N94-33127

Data are presented from evaluation tests of thick (96-ply) and thin (16-ply) stitched laminates and from selection tests of RTM resins. Tension strength, compression strength and post-impact compression strength data are reported. Also presented are the elements of a NASA Langley program to expand the science base for stitched/RTM. Completed tests on stitched laminates showed outstanding damage tolerance, and acceptable fatigue and hot, wet performance.

**69.** Lubowinski, S. J.; and Poe, C. C., Jr.: Fatigue Characterization of Stitched Graphite/Epoxy Composites. *Fiber-Tex 1987—First Conference on Advanced Engineering Fibers and Textile Structures for Composites*, NASA CP-3001, Part 1, 1988, pp. 253–271.

Results are presented for the fatigue response of non-woven fabric composites with various amounts of through-the-thickness stitching. Forty ply unnotched laminates were tested in tension-compression and compression-compression fatigue at 10 Hz. Stitching was observed to improve the fatigue life of laminates.

**70.** Palmer, R. J.; Dow, M. B.; and Smith, D. L.: Development of Stitching Reinforcement for Transport Wing Panels. *First NASA Advanced Composites Technology Conference*, NASA CP-3104, Part 2, 1991, pp. 621–646.

Researchers at Douglas Aircraft Company and NASA Langley Research Center are investigating stitching reinforcement combined with resin transfer molding to produce improvements in composite materials. Empirical guidelines are being established for stitching

reinforcements in structures designed to carry heavy loads. Results are presented from tests investigating stitching types, thread material and density (penetrations per square inch). Tension strength, compression strength, and compression strength after impact data are reported.

**71.** Poe, C. C., Jr.; Jackson, W. C.; Portanova, M. A.; and Masters, J. E.: Damage Tolerance of Textile Composites. *Fourth NASA Advanced Composites Technology Conference*, NASA CP-3229, Vol. 1, Part 2, 1993, pp. 629–664.

Results are presented from residual tension and compression strength tests of composite laminates that were impacted by falling weights or were statically indented. The textile composites were made from dry carbon fabric preforms using resin transfer molding. The fabric preforms were made by braiding, weaving and stitching. Test results from the textile materials are compared to conventional laminates made using toughened epoxy resin. Some stitched composites demonstrated damage resistance nearly equal to that of the toughened resin laminates.

**72.** Portanova, M. A.; Poe, C. C., Jr.; and Whitcomb, J. D.: *Open-Hole and Post-Impact Compression Fatigue of Stitched and Unstitched Carbon/Epoxy Composites*. NASA TM-102676. Also available as ASTM Proceedings, Vol. 10, 1992, pp. 37–53.

N90-25370

Results are reported from a study of the fatigue behavior of a stitched uniweave fabric composite and a toughened prepreg tape composite. Post impact compression fatigue and open hole fatigue tests were run on an AS4/3501-6 uniweave with stitching and a toughened IM7/8551-7 tape without stitching. The two materials were compared on an equal carbon content basis as well as on an equal weight basis. Comparison of fatigue lives on an equal carbon content basis indicated that puncture or crimp type damage from stitching has very little effect on compression failure. The increase in thickness from stitching results in a weight penalty.

**73.** Reeder, J. R.: Stitching vs. a Toughened Matrix: Compression Strength Effects. *J. Compos. Mater.*, vol. 29, no. 18, 1995, pp. 2464–2487.

The compression strength of a stitched and a toughened matrix graphite/epoxy composite was determined and compared to a baseline unstitched untoughened composite. Two different lay-ups with a variety of test lengths were tested under both ambient and hot/wet conditions. At longer gage lengths where failure was due to global buckling, no significant difference in strength was found between the different materials. For shorter specimens, a 30% reduction in strength due to stitching was

found for both lay-ups, presumably due to an increase in fiber misalignment. The toughened material showed a small increase in strength over the baseline material. A hot/wet environment reduced the strength of the baseline and stitched material by 30% and the toughened material by 20%.

**74.** Reeder, J. R.: *Comparison of the Compressive Strengths for Stitched and Toughened Composite Systems*. NASA TM-109108.

The compression strength of a stitched and a toughened matrix graphite/epoxy composite was determined and compared to a baseline unstitched untoughened composite. Two different lay-ups with a variety of test lengths were tested under both ambient and hot/wet conditions. No significant difference in strength was seen for the different materials when the gage lengths of the coupons were long enough to lead to a buckling failure. For shorter coupons, stitching caused a 30 percent reduction in strength from the baseline value. Analysis of the results suggested that the decrease in strength was due to increased fiber misalignment caused by the stitches.

N94-32939

**75.** Reid, R. L.; Hardee, H.; and El-Shiekh, A.: Joining Composite Materials: Bearing Behavior of 2-D and 3-D Braided Composites. *Materials Challenge Diversification and the Future—Proceedings of the 40th International Symposium and Exhibition*, Book 1, SAMPE, 1995, pp. 802–809.

Results are reported from tension bearing tests of braided coupons with mechanical fasteners. The test results show that the ranges for width-to-diameter ratio and edge distance-to-diameter ratio recommended for tape laminates are also suitable for braided composites.

**76.** Sankar, B. V.; and Sharma, S.: *Effects of Stitching on Fracture Toughness of Uniweave Textile Graphite/Epoxy Laminates*. NASA CR-195042.

Results are reported from experimental studies of the effects of through-the-thickness stitching on impact damage resistance, impact damage tolerance, and Mode 1 and Mode 2 fracture toughness of textile graphite/epoxy laminates. The results show that CAI strength can be improved up to 400 percent by through-the-thickness stitching. Double Cantilever Beam tests showed that Mode 1 fracture toughness is increased 30 times for a low stitching density of 16 stitches/sq. in.).

**77.** Sankar, B. V.; and Sharma, S.: Effects of Stitching on Fracture Toughness of Uniweave Textile Graphite/Epoxy Laminates. *Mechanics of Textile Composites Conference*, NASA CP-3311, Part 2, 1995, pp. 481–507.

N96-17713

The effects of through-the-thickness stitching on impact damage resistance, impact damage tolerance, and Mode I and Mode II fracture toughness of textile graphite/epoxy laminates were studied experimentally. The cloths were stitched with Kevlar and glass yarns before resin infusion. Delaminations were implanted during processing to simulate impact damage. The results show that CAI strength can be improved up to 400 percent by through-the-thickness stitching. Double Cantilever Beam tests showed that Mode I fracture toughness increased 30 times for a low stitching density of 16 stitches/sq. in.

**78.** Sharma, S. K.; and Sankar, B. V.: Effect of Stitching on Impact and Interlaminar Properties of Graphite/Epoxy Laminates. *9th American Society for Composites Technical Conference*, Technomic Publ. Co., Inc., 1994, pp. 700–708.

Stitching was not observed to have any significant effect on impact damage resistance. However, stitching leads to significant improvement (25-40 percent) in impact damage tolerance as measured by CAI strength and impact damage area. Mode I fracture toughness as characterized by critical strain energy release rate was found to be at least an order of magnitude higher than the unstitched laminates. Mode II fracture toughness increased by 5-15 times over the unstitched laminates. New methods are presented to estimate Mode II critical strain energy release rate in the stitched laminates. A95-20876

**79.** Sharma, S. K.; and Sankar, B. V.: Sublaminar Buckling and Compression Strength of Stitched Uniweave Graphite/Epoxy Laminates. *10th Technical Conference of the American Society for Composites*, Technomic Publishing Co., Inc., 1995, pp. 143–151.

A96-19740

Effects of through-the-thickness stitching on the sublaminar buckling and residual compression strength of graphite/epoxy uniweave laminates were experimentally investigated. Three stitching variables: type of stitch yarn, weight of stitch yarn, and stitching density were studied. The improvement in the CAI strength of the stitched laminates was up to 400 percent compared to the unstitched laminates.

**80.** Vanderney, N. E.; Masters, J. E.; Poe, C. C., Jr.; and Morris, D. H.: Compression-Compression Fatigue of a Stitched Uniwoven Graphite/Epoxy Composite. *Compression Response of Composite Structures*—Proceedings of the Symposium, ASTM, 1994, pp. 258–277.

A95-41420

Results are reported from an experimental characterization of the fatigue response of stitched uniweave com-

posite materials. The performance of a stitched uniweave material system with an underlying AS4/3501-6 quasi-isotropic lay-up subjected to compression-compression fatigue loading was investigated. Stitched uniwoven graphite/epoxy laminates show great promise as a damage-tolerant composite material which is easily fabricated into large net-shaped parts and structures.

### Resin Processing and Modeling Technology

**81.** Claus, S. J.; and Loos, A. C.: RTM Process Modeling for Textile Composites. *Fiber-Tex 1988—Second Conference on Advanced Engineering Fibers and Textile Structures for Composites*, NASA CP-3038, 1989, pp. 349–365.

Results are presented from analytical modeling of the infiltration and cure of composite materials by resin transfer molding (RTM). The model considers changes in the permeability of the dry carbon fiber preform due to compaction pressure. Significant effects on resin infiltration times result from compaction pressure and temperature. With this model, production of a laminate by RTM can be analytically simulated.

**82.** Eichinger, D. A.; Kranbuehl, D. E.; Loos, A. C.; Weideman, M. H.; and Claus, S. J.: Resin Transfer Molding Processing Cycle Optimization. *Fiber-Tex 1989—Third Conference on Advanced Engineering Fibers and Textile Structures for Composites*, NASA CP-3082, 1990, pp. 217–226.

The resin transfer molding process is described and its benefits for textile composites are outlined. Results are presented from a sensor-model system for closed-loop control of the processing cycle. In actual structural fabrication, it is expected that sensor output will be compared to model predictions to provide direct control of the temperature-pressure cycle.

**83.** Hasko, G. H.; Dexter, H. B.; and Weideman, M. H.: Resin Transfer Molding of Textile Preforms for Aircraft Structural Applications. *Ninth DoD/NASA/FAA Conference on Fibrous Composites in Structural Design*—Second NASA ACT Conference, FAA Report DOT/FAA/CT-92-25, III, pp. 1303–1317.

N94-33121 N95-28276

This paper discusses experimental and analytical techniques that are under development at NASA Langley. Included are experimental techniques to characterize preform and resin behavior, and analytical methods developed to predict resin flow and cure kinetics. Resin transfer molding (RTM) of dry textile material forms appears to have considerable potential as a cost-effective fabrication method for primary composite aircraft structures. Textile composites have been shown to

offer significant improvements in damage tolerance compared to laminated tape composites.

**84.** Kranbuehl, D. E.; Hood, D.; Rogozinski, J.; Limburg, W.; Loos, A. C.; and MacRae, J.: In Situ FDEMS Sensing for Intelligent Automated Cure in Resin Transfer Molding of Advanced Architecture Textile Preforms. *Materials Challenge Diversification and the Future—Proceedings of the 40th International Symposium and Exhibition, Book 2, SAMPE, 1995, pp. 1466–1477.*

Frequency dependent electromagnetic sensing had been developed for in situ measurement of resin position, viscosity and degree of cure process. A science based multi-dimensional model of RTM has been developed which can successfully predict resin behavior during the resin flows into a dry carbon fiber preform.

**85.** Kranbuehl, D.; Eichinger, D.; Williamson, A.; Levy, D.; Reyzer, M.; Kingsley, P.; Hart, S.; and Loos, A. C.: On-Line In-Situ Control of the Resin Transfer Molding Process. *35th International Symposium and Exhibition, Book 1, SAMPE, 1990, pp. 825–834.*

A90-50119

This paper discusses the use of in-situ frequency-dependent electromagnetic sensors and the Loos-Springer model for selecting and controlling the processing properties of the resin transfer molding resin during impregnation and cure. Resin transfer molding of stitched fabrics promises to be a cost effective process for obtaining composite parts of exceptional strength.

**86.** Loos, A. C.; Hammond, V. H.; Kranbuehl, D. E.; and Hasko, G. H.: Textile Composite Processing Science. *Fiber-Tex 1992—Sixth Conference on Advanced Engineering Fibers and Textile Structures for Composites, NASA CP-3211, 1993, pp. 151–166.*

Results are presented from research to develop a multi-dimensional model for the resin transfer molding (RTM) process for fabricating textile composite structures. The model is intended to predict the infiltration behavior of an epoxy resin into an anisotropic carbon fabric preform. Frequency dependent electromagnetic sensing has been developed for in-situ monitoring of the RTM process. Test results are presented showing good agreement between model predictions, sensor readings and experimental data.

**87.** Loos, A. C.; MacRae, J. D.; Hammond, V. H.; Kranbuehl, D. E.; Hart, S. M.; Hasko, G. H.; and Markus, A. M.: Analytical Modeling and Sensor Monitoring for Optimal Processing of Advanced Textile Structural Composites by Resin Transfer Molding. *Third NASA Advanced Composites Technology Conference, NASA CP-3178, Part 1, 1993, pp. 361–379.*

A model of the resin transfer molding (RTM) process was developed which can be used to simulate the infiltration of resin into an anisotropic fibrous preform. Frequency dependent electromagnetic sensing (FDEMS) has been developed for in situ monitoring of the RTM process. Flow visualization tests were performed to obtain data which can be used to verify the sensor measurements and the model predictions. Results of the tests showed that FDEMS can accurately detect the position of the resin flow-front during mold filling, and that the flow-front patterns predicted with the model agreed well with the measured patterns.

**88.** Loos, A. C.; Weideman, M. H.; Long, E. R., Jr.; Kranbuehl, D. E.; Kinsley, P. J.; and Sean, M. H.: Infiltration/Cure Modeling of Resin Transfer Molded Composite Materials Using Advanced Fiber Architectures. *First NASA Advanced Composites Technology Conference, NASA CP-3104, Part 1, 1991, pp. 425–441.*

A model was developed to simulate infiltration and cure of textile composites by resin transfer molding. Fabric preforms were resin infiltrated and cured using optimized one-step infiltration/cure protocols generated by the model. Frequency dependent electromagnetic sensing (FDEMS) was used to monitor in situ resin infiltration and cure during processing. FDEMS measurements of infiltration time, resin viscosity, and resin degree of cure agreed well with values predicted by the simulation model. Textile composites fabricated using a one-step infiltration/cure procedure were uniformly resin impregnated and void free. Fiber volume fraction measurements by the resin digestion method compared well with values predicted using the model.

**89.** Weideman, M. H.; Loos, A. C.; Dexter, H. B.; and Hasko, G. H.: *An Infiltration/Cure Model for Manufacture of Fabric Composites by the Resin Infusion Process.* NASA CR-190154, Feb. 1992.

N92-21174

Results are reported from the development of a one-dimensional infiltration/cure model developed to simulate fabrication of advanced textile composites by the resin film infusion process. The simulation model relates the applied temperature and pressure processing cycles, along with the experimentally measured compaction and permeability characteristics of the fabric preforms, to calculate the temperature distribution, the resin degree of cure and viscosity, and the infiltration flow front position as a function of time. The model also predicts the final panel thickness, fiber volume fraction, and resin mass for full saturation as a function of compaction pressure.

## Mechanics of Textile Materials and Structures

**90.** Bogdanovich, A. E.: Three-Dimensional Analysis of Anisotropic Spatially Reinforced Structures. *Fiber-Tex 1992—Sixth Conference on Advanced Engineering Fibers and Textile Structures for Composites*, NASA CP-3211, 1993, pp. 271–304.

A material-adaptive three-dimensional analysis is proposed for inhomogeneous structures based on the meso-volume concept and application of deficient spline functions for displacement approximations. The application of the methodology to textile composite materials is described. Results are presented from several numerical calculations for woven and braided rectangular composite plates and stiffened panels under transverse bending. Some typical effects of stress concentrations due to the material inhomogeneities are demonstrated.

**91.** Chen, P.; and El-Shiekh, A.: Designing 3-D Braided Preforms for Composites: A Process Model. *Materials Challenge Diversification and the Future—40th International Symposium and Exhibition*, Book 1, SAMPE, 1995, pp. 810–820.

A process model had been developed to describe the relationship among fiber volume fraction, braid angle, preform dimensions, and machine set-up. The model predicts directional volume fractions and braid-braidability of preforms consistent with machine limitations.

**92.** Dellinger, G.; and Foye, R. L.: An Approximate Method of Stress Analysis for Fabric Reinforced Composites. *Fiber-Tex 1989—Third Conference on Advanced Engineering Fibers and Textile Structures for Composites*, NASA CP-3082, 1990, pp. 315–329.

Results are presented from an analysis of intermediate complexity based on finite element treatment of a relatively simple unit cell model. The mathematical model does not require matching element nodes and boundaries to the material boundaries within the unit cell. Based on the work completed, it is concluded that special purpose stress codes can be developed for textile composites.

**93.** Dickinson, L. C.: Trans-Laminar-Reinforced (TLR) Composites. Ph.D. Thesis, The College of William and Mary, Virginia, 1997.

A Trans-Laminar-Reinforced (TLR) composite is defined as a composite laminate with up to five percent volume of fibrous reinforcement oriented in a “trans-laminar” fashion in the through-thickness direction. It has been repeatedly documented in the literature that adding TLR to an otherwise two dimensional laminate results in the following advantages: substantially improved compression-after-impact response, increased fracture toughness, and reduced growth of delaminations. The objective of this research was to characterize the

effects of TLR on the in-plane and inter-laminar mechanical response of undamaged composite laminates. Finite element analyses showed that adding a few percent TLR has a small negative effect on in-plane extensional and shear moduli but had a large positive effect (up to 60 percent) on the thickness direction extensional modulus.

**94.** Dow, N. F.; and Henstenburg, R. B.: *Development of Through-the-Thickness Reinforced Triaxially Woven Composite Laminate Reinforcements*. NASA CR-187511, 1991.

Results are reported from a design study of triaxially woven, multi-layer fabric reinforcement concepts. Several new designs are reported and their properties are predicted. Multi-layer woven fabrics can be designed to have a significant portion of the fibers running through the thickness to improve both the interlaminar shear and damage tolerance.

**95.** Dow, N. F.; and Ramnath, V.: *Analysis of Woven Fabrics for Reinforced Composite Materials*. NASA CR-178275, 1987.

Results are reported from studies (1) to identify advances in analysis required for the complex woven configurations becoming available including crimp effects; (2) progress toward development of criteria for through-the-thickness reinforcement; and (3) generation of guidelines for improved three-dimensional (multi-directional) weaves.

**96.** Dow, N. F.; and Ramnath, V.: Evaluations and Criteria for 3-D Composites. *3-D Composite Materials—Proceedings of a NASA/Navy Working-Group*, NASA CP-2420, 1986, pp. 5–30.

Material Sciences Corp. has performed studies to develop realistic models and approaches for the structural characterization of complex textile composites. For elastic properties, the most successful approach is the NDPROP prediction code. Analysis results indicate that straight through-the-thickness reinforcement is preferred. Hybrid constructions with Kevlar should be exploited for lower material cost and better damage resistance.

**97.** Dzenis, Y. A.; Bogdanovich, A. E.; and Pastore, C. M.: Stochastic Damage Evolution in Textile Laminates. *Fiber-Tex 1992—Sixth Conference on Advanced Engineering Fibers and Textile Structures for Composites*, NASA CP-3211, 1993, pp. 235–248.

A probabilistic model is described that uses random material characteristics to predict damage evolution in textile laminates. The model is based on a division of each ply into two sublaminas consisting of cells. The probability of cell failure is calculated using stochastic function theory and maximal strain failure criterion. A

numerical algorithm was developed to predict the damage evolution in textile composites.

**98.** Flanagan, G.; and Furrow, K.: Parametric Studies of Stitching Effectiveness in Preventing Substructure Disbond. *Mechanics of Textile Composites Conference*, NASA CP-3311, Part 2, 1995, pp. 539–554.

The analysis approach is to treat substructure disbond as a crack propagation problem. The strain-energy-release-rate (G) is calculated using a code which interconnects higher order plates to model built-up composite cross-sections. A series of tests were performed to exercise the analysis methodology. Design charts are given for simple part geometries.

**99.** Foye, R. L.: The Mechanics of Fabric-Reinforced Composites. *Fiber-Tex 1988—Second Conference on Advanced Engineering Fibers and Textile Structures for Composites*, NASA CP-3038, 1989, pp. 237–247.

A description is given of a proposed analysis for predicting the elastic moduli of fabric-reinforced composites. The proposed analysis places no restrictions on fabric micro-geometry except that it be determinate within some repeating rectangular pattern.

**100.** Foye, R. L.: Thermal Expansion of Fabric Reinforced Composites. *Fiber-Tex 1990—Fourth Conference on Advanced Engineering Fibers and Textile Structures for Composites*, NASA CP-3128, 1991, pp. 167–178.

An analytical method is presented for estimating coefficients of thermal expansion for textile composites. Several analytical methods exist for calculating the 3-D elastic constants of textile composites. The present method is based on the existing methods for elastic constants and involves the application of a single thermal load case to the unit cell structure. A limited amount of experimental correlation is presented.

**101.** Glaessgen, E. H.; and Griffith, O. H., Jr.: Finite Element Based Micro-Mechanics Modeling of Textile Composites. *Mechanics of Textile Composites Conference*, NASA CP-3311, Part 2, 1995, pp. 555–586.

Traditional approaches to the study of textile composites neglect many of the geometric details that influence the performance of the material. The present 3-D analysis, based on the representative volume element of a plain weave, permits the analyst to predict the internal details of displacement, strain, stress and failure. This analysis allows study of the effect of geometric and material parameters.

**102.** Gowayed, Y. A.; and Pastore, C. M.: Analytical Techniques for Textile Structural Composites: A Comparative Study of US-USSR Research. *Fiber-Tex 1990—Fourth Conference on Advanced Engineering Fibers and*

*Textile Structures for Composites*, NASA CP-3128, 1991, pp. 145–166.

A discussion is made of different analytical techniques for the analysis of textile structural composites. The discussion covers the assumptions and limitations of various continuum and discrete models and includes comparisons of the techniques. Analytical methods for structural composites developed by American and Soviet researchers are presented and evaluated on the basis of published data.

**103.** Hyer, M. W.; Lee, H. H.; and Knott, T. W.: *A Simple Evaluation of Thermally-Induced Stresses in the Vicinity of the Stitch in a Through-Thickness Reinforced Cross-Ply Laminate*. NASA CR-196317, 1994.

N94-37653

The stresses are computed in the vicinity of a single stitch through the thickness of an infinite cylindrical cross-ply laminate subjected to a unit temperature decrease. Interest centers on the potential for microcracking in the vicinity of the through-thickness reinforcement. Both glass and Kevlar stitches are considered, as is the possibility of resin pockets forming near the stitch.

**104.** Li, W.; and El-Shiekh, A.: Structural Mechanics of 3-D Braided Preforms for Composites Part 2: Geometry of Fabrics Produced by the Two-Step Process. *Fiber-Tex 1988—Second Conference on Advanced Engineering Fibers and Textile Structures for Composites*, NASA CP-3038, 1989, pp. 249–265.

This paper presents the structural geometries of the composite preforms produced by the two-step, 3-D process. Based on an idealized structural model, geometric relations between the structural parameters of the preform are calculated and related to the machine operating conditions. The braider orientation, braider retraction, preform contour size, and yarn volume fraction are predicted and compared with experimental results. Fair agreement is achieved between predictions and experimental results.

**105.** Long, E. R., Jr.; Kullerd, S. M.; Johnston, P. H.; and Madaras, E. I.: Ultrasonic Detection and Identification of Fabrication Defects in Composites. *First NASA Advanced Composites Technology Conference*, NASA CP-3104, Part 2, 1991, pp. 705–720

Results are presented from a study of methods for introducing porosity in carbon/epoxy composite panels and the influence of three-dimensional stitching on the detection of porosity. Two methods of introducing porosity were investigated: inclusion of glass microspheres, and deliberate use of low pressure during consolidation. The panels were ultrasonically scanned and the frequency slope of the ultrasonic attenuation coefficient was

used to evaluate the two forms of porosity. The influence of stitching on the detection of porosity was studied using panels which were resin transfer molded from stitched plies of knitted carbon fabric and epoxy resin.

**106.** Naik, R. A.: Failure Analysis of Woven and Braided Fabric Reinforced Composites. *Fifth NASA/DoD Advanced Composites Technology Conference*, NASA CP-3294, Vol. 1, Part 2, 1995, pp. 571–613.

Results are presented from a general purpose micro-mechanics analysis for textile composites. The analysis discretely models the yarn architecture within the textile repeating unit cell. It was developed to predict properties (overall, three dimensional, thermal and mechanical), damage initiation and progression, and strength. The calculated tension, compression, and shear strengths correlate well with available test data for both woven and braided composites. Parametric studies were performed on both woven and braided architectures.

**107.** Naik, R. A.: TEXCAD—Textile Composite Analysis for Design. *Mechanics of Textile Composites Conference*, Part 2, NASA CP-3311, 1995, pp. 587–596.

The TEXCAD code provides a desktop computer tool for the analysis of fabric reinforced woven and braided composites. It can be used to calculate overall thermal and mechanical properties along with engineering estimates of damage progression and strength. The code also calculates laminate properties for stacked, oriented fabric.

**108.** Pastore, C. M.: Quantification of Processing Artifacts in Textile Composites. *Fiber-Tex 1992—Sixth Conference on Advanced Engineering Fibers and Textile Structures for Composites*, NASA CP-3211, 1993, pp. 215–234.

A model has been developed for idealized reinforcements to provide an insight into the local behavior. However, observations of micrographical images reveals that the actual material deviates considerably from the idealized models. Deviations and causes are described for triaxial braids and 3-D woven textile composites. The modeling steps are presented to account for the variations.

**109.** Pastore, C. M.; Birger, A. B.; and Clyburn, E.: Geometric Modeling of Textile Reinforcements. *Mechanics of Textile Composites Conference*, NASA CP-3311, Part 2, 1995, pp. 597–531.

Results are presented of work to develop a methodology for characterizing the geometry of yarns within a textile preform. Experimental techniques for evaluating the models are discussed. Applications of the geometric results to mechanical property prediction models are demonstrated.

**110.** Poe, C. C., Jr.: Mechanics Methodology for Textile Preform Composite Materials. *Technology Transfer in a Global Community—Proceedings of the 28th International Technical Conference*, SAMPE, 1996, pp. 324–338.

NASA and its subcontractors have completed a program to develop a basic mechanics underpinning for textile composites. Three major deliverables were: test methods for measuring material properties and design allowables; mechanics models for moduli, strength, damage resistance, and fatigue life; and an electronic data base of coupon type test data. Results are contained in three NASA reports: Standard Test Methods for Textile Composites, Handbook of Analytical Methods for Textile Composites, and Database of Mechanical Properties for Textile Composites.

**111.** Poe, C. C., Jr.; Harris, C. E.; Coats, T. W.; and Walker, T. H.: Tension Strength with Discrete Source Damage. *Fifth NASA/DoD Advanced Composites Technology Conference*, NASA CP-3294, Vol. 1, Part 1, 1995, pp. 369–437.

This paper presents the results of applying linear elastic fracture mechanics (LEFM) to predict the strength of wing and fuselage panels. Contractors in the NASA ACT program fabricated several large unstiffened and stiffened flat panels which were tested with simulated discrete source damage. Predictions using LEFM were found to be overly conservative and a new method using a pseudo R-curve was developed to improve predictions. A prediction with the new method, however, seriously underestimated the tension strength of a stitched wing panel in which crack turning occurred.

**112.** Raju, I. S.; and Wang, J. T.: Classical Laminate Theory Models for Woven Fabric Composites. *J. Compos. Technol. & Res.*, JCTRER, vol. 16, no. 4, Oct. 1994, pp. 289–303.

Improved classical laminate theory models are presented for woven fabric preform composites. These models retain the simplicity of the fiber undulation model and the bridging model developed by Chou and Ishikawa but do not have the restrictive assumptions made to simplify their analysis. The present model results for moduli and Poisson's ratio agree well with results from other models and with the limited experimental data.

**113.** Sankar, B. V.; and Marrey, R. V.: Micromechanical Models for Textile Composites. *Mechanics of Textile Composites Conference*, NASA CP-3311, Part 2, 1995, pp. 625–31.

Numerical and analytical micromechanical models are presented to predict the thermo-elastic behavior of a textile composite. The numerical model is used to predict

the properties of a thin textile laminate and extended to compute processing stresses.

**114.** Sankar, B. V.; and Sonik, V.: Modeling End-Notched Flexure Tests of Stitched Laminates. *10th Technical Conference of the American Society for Composites*, Technomic Publ. Co., Inc., 1995, pp. 172–181.

A96-19743

Results are presented from an experimental and finite element analysis of unidirectional graphite/epoxy laminates fabricated using stitched AS4 fabric and 3501-6 epoxy resin. Starter delaminations were implanted in the middle layer of the plate. Some of the laminates were stitched through-the-thickness using Kevlar (400 denier) needle yarn and Kevlar (1600 denier) and glass (3570 and 5950 denier) bobbin yarns. End notched flexure tests were performed to determine the effects of stitching on the Mode II fracture toughness of the laminates.

**115.** Sankar, B. V.; and Sonik, V.: Pointwise Energy Release Rate in Delaminated Plates. *AIAA J.*, vol. 1, no. 1, 1955.

A95-19099

A laminated plate theory has been derived which is suitable for analyzing delaminations. The theory is used to study the interaction between the top and bottom sublaminates in the intact region of a delaminated plate. Expressions are derived for the jump in force and moment resultants that occur across the delamination front. Using Irwin's crack closure integral, a simple expression for pointwise strain energy release rate along the delamination front has been derived.

**116.** Shahid, I.; Lee, S.; Chang, F. K.; and Shah, B. M.: Impact Damage in Composite Plates. *Mechanics of Textile Composites Conference*, NASA CP-3311, Part 2, 1995, pp. 509–538.

The approach is described for linking a progressive damage analysis code, PDCOMP, with an impact prediction code, 3DIMPACT, in order to predict damage accumulated inside composites as a function of applied loads; and estimate residual ply properties as a function of damage state and failure mode. The analysis is limited to symmetric laminates and ignores edge effects.

**117.** Wei, L.; Kang, T. J.; and El-Shiekh, A.: Structural Mechanics of 3-D Braided Preforms for Composites. *Fiber-Tex 1987—First Conference on Advanced Engineering Fibers and Textile Structures for Composites*, NASA CP-3001, Part 1, 1988, pp. 115–133.

This paper presents the microstructure of 3-D braided composite preforms produced by a four step machine process. The effects of machine operating

parameters on yarn orientation, yarn crimp, preform dimensions, and yarn volume fraction are theoretically predicted and compared with experimental observations.

**118.** Wigent, D. E.; Mohamed, M. H.; and Fahmy, A. A.: Fracture and Fatigue in a 3-D Carbon Fiber/Epoxy Composite. *Material and Process Challenges: Aging Systems, Affordability, Alternative Applications—Proceedings of the 41st International Symposium and Exhibition*, Book 2, SAMPE, 1996, pp. 1217–1229.

Results are reported from an experimental investigation of fracture and fatigue in 3-D composite. Compact tension specimens were prepared and tested by methods based in part on ASTM E 647-78T. The failure modes observed were much different than those of conventional laminates. Fatigue loading did not result in fiber failure or delaminations. The 3-D materials demonstrated toughness, resistance to delamination and resistance to edge induced failures.

**119.** Whitcomb, J.; and Srengan, K.: Effect of Various Approximations on Predicted Progressive Failure in Plain Weave Composites. *Mechanics of Textile Composites Conference*, NASA CP-3311, Part 2, 1995, pp. 665–681.

Three-dimensional finite element analysis was used to simulate progressive failure of a plain weave composite subjected to in-plane extensions. The effects were examined of various characteristics of the finite element model on predicted behavior. Also studied was the effect of tow waviness on the sensitivity of the predictions. The predicted strength decreased considerably with increases in tow waviness.

### Overviews and Summaries

**120.** Bohon, H. L.; and Davis, J. G., Jr.: Advanced Composites Technology Status and Opportunities. *Fiber-Tex 1989—Third Conference on Advanced Engineering Fibers and Textile Structures for Composites*, NASA CP-3082, 1990, pp. 3–22.

As the principal factors which prevent the widespread use of composites in transport primary structures, the aircraft industry has identified an inadequate data base, lack of confidence in structural performance and uncertain costs. This overview paper discusses how these inhibiting factors may be removed with emerging new material forms and innovative manufacturing processes. Use of these advanced materials and processes should result in integrated design and manufacture of structures with acceptable damage tolerance capabilities and structural performance predictable by analyses. Areas of research are identified which require strong government support.



**121.** Dexter, H. B.: An Overview of the NASA Textile Composites Program. *Fiber-Tex 1992—Sixth Conference on Advanced Engineering Fibers and Textile Structures for Composites*, NASA CP-3211, 1993, pp. 1–31.

A summary overview is presented of the program being conducted and managed by the NASA Langley Research Center to explore the benefits of textile reinforced composites for civil transport aircraft primary structures. In addition to Langley in-house research, the program includes major participation by the aircraft industry and aerospace textile companies. The major program elements include development of textile preforms, processing science, mechanics of materials, characterization of materials, and evaluation of structural elements and subcomponents. Included in the subcomponents are braided frames and woven/stitched wing and fuselage panels.

**122.** Dexter, H. B.: Innovative Textile Reinforced Composite Materials for Aircraft Structures. *Technology Transfer in a Global Community—Proceedings of the 28th International Technical Conference*, SAMPE, 1996, pp. 404–416.

During the past 15 years NASA has played the lead role in exploiting the benefits of textile reinforced composites for aircraft applications. The structural elements developed under the NASA Advanced Composites Technology Program are discussed in this paper. Among the elements discussed are: braided fuselage frames and window-belt reinforcements, woven/stitched lower fuselage side panels, stitched multiaxial warp knit wing skins, and braided wing stiffeners. A description is presented of analytical models to predict epoxy resin flow and cure in textile preforms. Selected test results are discussed.

**123.** Dexter, H. B.; and Maiden, J.: Application of Textile Material Forms to Composite. Aircraft Structures. *Fiber-Tex 1987—First Conference on Advanced Engineering Fibers and Textile Structures for Composites*, NASA CP-3001, Part 1, 1988, pp. 91–113.

This paper addresses the application of automated textile technologies for the production of composite material forms which possess inherent damage tolerance. Fiber interlacing and through-the-thickness reinforcement of woven, braided, knitted, and stitched materials provide improvements in damage tolerance and fracture toughness compared to conventional tape laminate composites. Limitations of textile processes and key technology development needs are discussed.

**124.** Dexter, H. B.; and Stein, B. A.: Advanced Composite Materials for Airframe Structures. *Fiber-Tex 1987—First Conference on Advanced Engineering Fibers and Textile Structures for Composites*, NASA CP-3001, Part 1, 1988, pp. 1–29.

If the full potential of composite materials is to be achieved, changes are required in materials, design concepts, and fabrication methods. The changes required include: new analytical tools to extrapolate to the next generation of structural designs; new material architectures such as stitching, braiding and weaving. An expanded composites research and development activity is essential, if we are to maintain world wide competitiveness in aircraft manufacturing,

**125.** Dexter, H. B.; Harris, C. E.; and Johnston, N. J.: Recent Progress in the NASA Langley Textile Reinforced Composites Program. *Second NASA Advanced Composites Technology Conference*, NASA CP-3154, 1992, pp. 295–323.

A research program is described that aims to explore the benefits of textile reinforced composites for civil transport aircraft primary structures. The participants are identified from industry, academic and government. Test results are presented from a comparison of textile laminates made using woven, braided and stitched preforms with conventional tape laminates. The goal of the NASA program is to demonstrate technology readiness with subscale components by 1995 and full-scale primary structure components by 1997. N95-28475

**126.** Dexter, H. B.; Camponeschi, E. T.; and Peebles, L.: Compilers and Editors of *3-D Composite Materials*, NASA CP-2420, 1986.

Proceedings of a working-group meeting sponsored by the NASA Langley Research Center and the Office of Naval Research; held at Annapolis, MD, Nov. 5-7, 1985.

**127.** Freeman, W. T., Jr.: Advanced Composites Technology Program Overview. *Fiber-Tex 1989—Third Conference on Advanced Engineering Fibers and Textile Structures for Composites*, NASA CP-3082, 1990, pp. 23–50.

This paper provides the background, schedule and program content for the NASA Advanced Composites Technology (ACT) Program. The program involving NASA and 15 companies and universities will perform research in materials and material form to improve structural performance and reduce processing and manufacturing costs. Analytical methodologies will be developed. Methods will be verified by tests at the element, subcomponent and component level. Innovative structural concepts and fabrication methods will be explored and selected.

**128.** Poe, C. C., Jr.; and Harris, C. E.: Mechanics Methodology for Textile Preform Composite Materials. *Sixth NASA/DoD Advanced Composites Technology Conference*, NASA CP-3326, Vol. 1, Part 1, 1996, pp. 95–130.

NASA Langley Research Center planned and managed a program to provide basic science underpinnings for textile composites. The program had three primary objectives: first, develop test methods; second, develop mechanics models; and third, conduct extensive tests. This paper identifies the participants and summarizes the results of the completed program. FEDD restricted until June 30, 1998.

**129.** Poe, C. C., Jr.; and Harris, C. E.: Compilers and Editors of *Mechanics of Textile Composites Conference*. NASA CP-3311, Parts 1 and 2, 1995.

Proceedings of a conference sponsored by NASA; held at Hampton, VA, Dec. 6-8, 1994.

**130.** Wilson, D. W.: Potential Effects of Regulatory Issues on Textile-Based Composites Applications. *Fiber-Tex 1990—Fourth Conference on Advanced Engineering Fibers and Textile Structures for Composites*, NASA CP-3128, 1991, pp. 3–24.

Fundamental materials science and manufacturing technology are clearly the technical keys to the future of the advanced composites materials business. However, the regulatory process significantly influences the cost and time for developing the business. Full characterization and qualification of a material or manufacturing process is very expensive and time consuming. This paper discusses a Suppliers of Advanced Composite Materials Association (SACMA) supported initiative to bring about industry wide standards for materials specification and characterization.

## ACT Textile Composites Program

### Dow Chemical Company - RTM Resins

**131.** Woo, E. P.; Puckett, P. M.; and Maynard, S. J.: Development of Resins for Composites by Resin Transfer Molding. *First NASA Advanced Composites Technology Conference*, NASA CP-3104, Part 2, 1991, pp. 647–658.

The Dow Chemical Company was awarded a NASA contract for the development of resins with improved processibility and properties for primary aircraft structures. The contract has three objectives: (1) RTM resins with improved processibility and properties, (2) prepreg systems with high toughness and service temperature, and (3) new resin matrix concepts. This paper presents progress toward meeting the objectives and plans for future work.

### Lockheed Martin - Material and Structural Concepts

**132.** Chu, R. L.: Braided Frame Design Trade Studies. *50 Years of Progress in Materials Science and Technology—Proceedings of the 26th International Technical Conference*, SAMPE, 1994, pp. 142–151.

Lockheed investigated the use of 2-D triaxial braiding and 3-D through-the-thickness braiding as a means of reducing the cost of producing circumferential fuselage frames. This paper describes the design, analysis and structural testing performed to evaluate these braided frames. The results show that the 2-D braiding costs less and is lighter than the 3-D braiding for fuselage frames.

**133.** Chu, R. L.; Bayha, T. D.; Davis, H.; Ingram, J. E.; and Shukla, J. G.: *Advanced Composite Structural Concepts and Materials Technologies for Primary Aircraft Structures - Design/Manufacturing Concept Assessment*. NASA CR-4447, 1992.

Results are presented from design/manufacturing trade studies of a composite wing and a fuselage sized for application on the L-1011 transport aircraft. In developing the concepts no restrictions were placed on the choice of composite materials, processes or structural arrangement. Emphasis was placed on automated processes to reduce hand labor and manufacturing costs. Tooling requirements were considered but the emphasis was on reducing recurring costs, with tooling costs being amortized over a production run.

**134.** Dorris, W. J.; Hairr, J. W.; Huang, J. T.; Ingram, J. E.; and Shah, B. M.: *Advanced Composite Structural Concepts and Materials Technologies for Primary Aircraft Structures - Structural Response and Failure Analysis*. NASA CR-4448, 1992.

Results are reported from work to develop analysis methods and modeling techniques to accurately evaluate the response of stiffened structures under combined in-plane and out-of-plane loadings. The finite element approach was taken to address the complex interaction of nonlinearities due to pressurization, postbuckling and geometric configurations for stiffened structures representative of wing cover panels, fuselage shells, spar webs, bulkheads, and ribs.

**135.** Jackson, A. C.: *Advanced Composite Structural Concepts and Materials Technologies for Primary Aircraft Structures - Design, Analysis, Fabrication and Test - Executive Summary*. NASA CR-4727, 1996.

Textile composite preforms were developed for primary aircraft structural applications. Fuselage circumferential frames and window frames were braided and resin transfer molded for test and evaluation. Window belt reinforcements were designed and fabricated using

woven epoxy-powder-coated tows. Large, 8-foot by 10-foot panels were fabricated by automated tow placement and cobonded with braided frames. Tests were conducted to verify designs. Analytical methods were developed for the prediction of textile composite properties; the methods were verified by tests.

**136.** Jackson, A. C.; Barrie, R. E.; Adams, L. T., Jr.; Chu, R. L.; Kwon, Y. S.; Ott, L. M.; Shah, B. H.; Shukla, J. G.; and Skolnik, D. Z.: *Advanced Composite Structural Concepts and Materials Technologies for Primary Aircraft Structures - Design, Analysis, Fabrication and Test*. NASA CR-4726, 1996.

Textile composite preforms were developed for primary aircraft structural applications. Fuselage circumferential frames and window frames were braided and resin transfer molded for test and evaluation. Window belt reinforcements were designed and fabricated using woven epoxy-powder-coated tows. Large, 8-foot by 10-foot panels were fabricated by automated tow placement and cobonded with braided frames. Tests were conducted to verify designs. Analytical methods were developed for the prediction of textile composite properties; the methods were verified by tests.

**137.** Kuykendall, M. A.: Braided Frames Testing and Analysis. *50 Years of Progress in Materials Science and Technology—Proceedings of the 26th International Technical Conference*, SAMPE, 1994, pp. 746–758.

Lockheed created a design development test program, including an impact damage tolerance test, to evaluate 2-D and 3-D braided fuselage frames under bending loads. Details are presented of the design and analysis of the frames, bending test results, and the correlation of test results and analytical predictions.

**138.** Shah, B. M.: Textile Technology Development. *Mechanics of Textile Composites Conference*, NASA CP-3311, Part 2, 1995, pp. 425–455.

A summary is given of the approach and results obtained by Lockheed Aeronautical Systems in developing textile composites for fuselage applications. The goal was to identify and verify cost-effective textile composites for fuselage window frame and belt uses.

**139.** Shah, B. M.; Dorris, W. J.; and Kwon, Y. S.: Characterization of Textile Composites for Aircraft Structures. *Fourth NASA/DoD Advanced Composites Technology Conference*, NASA CP-3229, Part 2, 1993, pp. 665–682.

Results are presented from mechanical properties tests and limited tests to characterize failure modes in composites made from 3-D braids, 3-D layer-to-layer, and 3-D through-the-thickness weaves. A preliminary assessment of the test results indicates that the longitudi-

nal tension and compression strengths of 3-D textile composites are better than composites made with 8 harness satin fabric. No significant difference was observed in the low-impact-velocity damage tolerance of the textiles and 8HS composites. Shear failure was observed to be the dominate failure mode for the 3-D textiles composites.

**140.** Shah, B. M.; Pochiraju, K.; Bynum, J-H.; Parvizi-Majidi, A.; and Chou, T-W.: *Advanced Composite Structural Concepts and Materials Technologies for Primary Aircraft Structures - Design, Analysis, Fabrication and Test Appendices*. NASA CR-198301, 1996.

This report contains documentation of software for textile strength and stiffness prediction, plus user manuals for the software and the 3-D code IMPACT. Data summaries are given for the allowables tests conducted on various textile laminates.

**141.** Shukla, J. G.; and Bayha, T. D.: Advanced Resin Systems and 3-D Textile Preforms for Low-Cost Composite Structures. *Third NASA Advanced Composites Technology Conference*, NASA CP-3178, Part 1, 1993, pp. 159–173.

Under its ACT contract, Lockheed Aeronautical Systems Co. is investigating resin systems for resin transfer molding and powder epoxy towpreg materials. Information is presented for three developmental epoxy resins for RTM and three resins for powder prepregging. Various 3-D textile preforms incorporating advanced weaving and braiding process are also being evaluated. A review is presented of progress in advanced resin screening and textile preform development.

**142.** Shukla, J. G.; and Wu, S. Y.: *Advanced Composite Structural Concepts and Materials Technologies for Primary Aircraft Structures - Textile Preform Development and Processing*. NASA CR-4728, 1996.

Seven advanced textile processes (weaves, braids and knits) were evaluated for their mechanical performance, their process advantages and limitations, and their application in composite primary structures. All processing was done using PR-500 epoxy resin in either resin transfer molding or as powder-coated tow.

#### Lockheed Martin - Fabrication Studies

**143.** Adams, L. T.; Barrie, R. E.; Leger, C. A.; and Skolnik, D. Z.: Braided/RTM Fuselage Frame Development. *Fifth NASA/DoD Advanced Composites Technology Conference*, NASA CP-3294, Vol. 1, Part 2, 1995, pp. 615–634.

Based on Boeing design requirements, circumferential fuselage frames have been developed by Lockheed using 2-D braided preforms and resin transfer molding

(RTM). Frame segments were fabricated and tested to evaluate their integrity and the potential for cost and weight reductions. The test results are presented and fabrication lessons are discussed. Scale-up issues for 2-D braiding and RTM are addressed.

**144.** Barrie, R. E.; and Skolnik, D. Z.: Evaluation of Textile Composites for Fuselage Frames. *Fourth NASA/DoD Advanced Composites Technology Conference*, NASA CP-3229, Part 2, 1993, pp. 719–734.

Progress is reported on the application of textile composites in circumferential fuselage frames as a means of increasing the damage tolerance and reducing the cost. Work to date has concentrated on braiding with uncoated tows and RTM processing.

**145.** Barrie, R. E.; Chu, R. L.; Shukla, J. G.; Hugh, M. K.; Marchello, J. M.; and Johnston, N. J.: Advances in Powder-Coating Technology and Its Application to Fuselage Structures. *Fifth NASA/DoD Advanced Composites Technology Conference*, NASA CP-3294, Volume 1, Part 2, 1995, pp. 525–548.

Efforts at Lockheed Aeronautical Systems Company have led to the development of primary fuselage design concepts that utilize established textile technologies. Industry and NASA Langley have developed several methods of prepregging carbon tows with dry thermoplastic and thermosetting polymer powder and have evaluated the towpregs for textile processing. Significant progress has been made in weaving towpreg, but many of the lessons learned do not seem to apply to braiding towpregs.

**146.** Bayha, T. D.; Osborne, P. P.; Thrasher, T. P.; Hartness, J. T.; Johnston, N. J.; Baucom, R. M.; Marchello, J. M.; and Hugh, M. K.: Processing, Properties and Applications of Composites Using Powder-Coated Epoxy Towpreg Technology. *Fourth NASA/DoD Advanced Composites Technology Conference*, NASA CP-3229, Part 2, 1993, pp. 735–755.

Results are reported from studies of 2-D braiding and weaving using powder-coated towpreg to determine the effect of resin content, towpreg size and twist on composite properties. Studies have been made to customize the towpreg to reduce friction and bulk factor. Processing parameters are discussed for three epoxy resins on eight-harness satin fabric and on 3-D fabric architectures. Processing effects and the resultant mechanical properties are presented and compared.

**147.** Jackson, A. C.: Resin Coated Tow Materials for Structural Textile Preforms. *Technology Transfer in a Global Community—Proceedings of the 28th International Technical Conference*, SAMPE, 1996, pp. 417–426.

Powder-coated tow technology has been advanced significantly in the last few years. Woven preforms of epoxy-coated tows produce excellent quality structural components. Improvements in the coating process have reduced the preform bulk factor (a serious problem early in the development cycle) and have greatly improved the tow smoothness.

**148.** Jackson, A. C.; Barrie, R. E.; Shah, B. M.; and Shukla, J. G.: Advanced Textile Applications for Primary Aircraft Structures. *Ninth DoD/NASA/FAA Conference on Fibrous Composites in Structural Design—Second NASA ACT Conference*, FAA Report DOT/FAA/CT-92-25, II, pp. 875–901. (NASA CP-3154, 1992, pp. 325–352).

Results are reported by Lockheed Aeronautical Systems Company from their investigation of: material systems, near-net-shape textile preforms, four structural components (fuselage frames, window belt insert, keel beam/frame intersections, and a skin/stiffened fuselage panel), and innovative tooling concepts.

**149.** Jackson, A. C.; Barrie, R. E.; Shah, B. M.; Shukla, J. G.; and Skolnik, D. Z.: Development of Advanced Composite Textile Structures with RTM and Powder Coated Tows. *Tenth DoD/NASA/FAA Conference on Fibrous Composites in Structural Design*, Report No. NAWCADWAR-94096-60, Volume I, pp. IV-61–IV-81.

Lockheed Aeronautical Systems Company reports good progress in the development of braided textile preforms for resin transfer molding fuselage frames. Keel frames have been fabricated using 2-D braided preforms. Both 2-D and 3-D braided side panels have been fabricated and tested. Developments are lagging in textile preforms using powder-coated tows because the tows lack the required flexibility and low coefficient of friction.

**150.** Shukla, J. G.; Wu, S. Y.; and Bayha, T. D.: *Advanced Composite Structural Concepts and Materials Technologies for Primary Aircraft Structures - Advanced Resin Systems for Textile Preforms*. NASA CR-194968, 1994.

Results are reported from an investigation of candidate epoxy resins for resin transfer molding (RTM) and for powder-coated towpreg to use in constructing primary aircraft structures. Three resins were evaluated for RTM and PR-500 was selected for its superior mechanical performance, processibility, and cost effectiveness. Similarly, three powder coating resins were evaluated and PS-501 was selected for its mechanical performance, processibility, and cost effectiveness.

**151.** Skolnik, D. Z.; Shukla, J. G.; Wu, S. Y.; and Osborne, P. P.: *Advanced Composite Structural Concepts and Materials Technologies for Primary Aircraft*

*Structures - Low-Cost Fabrication Development*. NASA CR-4729, 1996.

Computer software for a liquid injection molding system was enhanced to include resin cure kinetics and a constant resin injection rate. Powder coated tow process development included bagging, caul plate requirements and debulking trials. A toughened resin, PR-520 was evaluated. A light-weight mandrel was devised for fabricating full-scale fuselage frames.

### **Northrop Grumman - Material and Structural Concepts**

**152.** Ewen, J. R.; and Suarez, J. A.: Cross-Stiffened Continuous Fiber Structures. *Third NASA Advanced Composites Technology Conference*, NASA CP-3178, Part 1, 1993, pp. 287–308.

Grumman Aircraft Systems is evaluating the structural efficiency of carbon/epoxy cross-stiffened panel elements fabricated using innovative textile preforms and cost effective resin transfer molding and resin film infusion processes. Two 3-D woven preform assembly concepts have been defined for application to a representative window belt design in a commercial transport airframe. One 3-D preform is vertically woven in the plane of the window belt and the other is loom woven in a compressed state similar to an unfolded egg crate.

**153.** Suarez, J. A.; and Buttitta, C.: *Novel Composites for Wing and Fuselage Applications; Task 1 - Novel Wing Design Concepts*. NASA CR-198347, 1996.

Under its ACT contract, Grumman conducted design trade studies for wing designs that incorporated textile materials with innovative design concepts and advanced fabrication methods. Textile processes such as knitting, weaving, and stitching were used to produce carbon fiber preforms that were made into composite spars by RTM processing. The various material form/processing combinations were rated for structural efficiency and cost.

**154.** Suarez, J. A.; and Buttitta, C.: *Novel Composites for Wing and Fuselage Applications - Textile Reinforced Composites and Design Guidelines*. NASA CR-201612, 1996.

Northrop Grumman completed design development of textile preforms for continuous cross-stiffened panels with cut-outs. Design guidelines/analysis methodology are given for such textile structures. The development was expanded to include a fuselage side-panel component of a subsonic commercial airframe.

**155.** Suarez, J. A.; Sobel, L. H.; Egensteiner, W. A.; and Feldman, S. M.: Design, Analysis and Fabrication of Cross-Stiffened Primary Structure. *Fifth NASA/DoD*

*Advanced Composites Technology Conference*, NASA CP-3294, Vol. 1, Part 2, 1995, pp. 649–679.

Northrop Grumman describes the fabrication of 60 by 90-in. AS4 carbon fiber cross stiffened preforms with a 122-in. radius of curvature. The preforms were made using a 3-D weaving approach that provides continuous tows through the frame intersections. The preforms are processed by resin film infusion (RFI) using 3501-6 resin. Data are presented from element tests to assess the structural efficiency of the designs. A comparison is made of actual and projected acquisition costs for cross-stiffened fuselage structure.

**156.** Suarez, J.; and Dastin, S.: Comparison of Resin Film Infusion, Resin Transfer Molding and Consolidation of Textile Preforms for Primary Aircraft Structure. *Second NASA Advanced Composites Technology Conference*, NASA CP-3154, 1992, pp. 353–386.

N95-28477

Grumman Aircraft Systems is developing innovative design concepts and fabrication processes for damage tolerant primary structures. Attention is focused on the use of resin film infusion (RFI), resin transfer molding (RTM) and thermoplastic forming concepts. The fabrication of wing “Y” spars is described wherein four materials/processing methods are used. A comparison is presented of the structural efficiency, processibility, and projected acquisition cost of these representative spars.

### **Rockwell - Mechanics of Materials Studies**

**157.** Carter, W. C.; Cox, B. N.; Dadkhah, M. S.; and Morris, W. L.: An Engineering Model of Woven Composites Based on Micromechanics. *Third NASA Advanced Composites Technology Conference*, NASA CP-3178, Part 1, 1993, pp. 309–322.

This paper presents a review of the recently acquired knowledge of damage accumulation in woven composites and describes a practicable model of the macroscopic behavior in these and other complex composite architectures. Discussion is limited to uniaxial compressive loading.

**158.** Cox, B. N.: Delamination and Buckling in 3-D Composites. *J. Compos. Mater.*, vol. 28, no. 12, 1994, pp. 1114–1126.

Elementary analyses are applied to the buckling of stitched laminates and woven graphite-epoxy composites with three-dimensional (3-D) reinforcement that contain delamination cracks. The through-the-thickness fibers are assumed to provide continuous, linear restoring tractions opposing the deflection of the delaminated layer adjacent to the crack. A simple expression is derived for

the minimum density of through-the-thickness reinforcement required to suppress buckling of the delamination layer prior to failure by other mechanisms. It is shown that the quantity of through-the-thickness reinforcement in typical present laminates is considerably more than needed to suppress buckling.

**159.** Cox, B. N.: Modeling the Properties of 3-D Woven Composites. *Mechanics of Textile Composites Conference*, NASA CP-3311, Part 1, 1995, pp. 455–479.

The results and models summarized in this paper are the outcome of several years work funded by the NASA ACT Program. An extensive study has been completed of the internal geometry, the mechanisms of failure, and the micromechanics of local failure events in graphite/epoxy composites with 3-D woven reinforcement. This work has led to the development of models for predicting elastic constants, strength, notch sensitivity, and fatigue life.

**160.** Cox, B. N.; Carter, W. C.; Dadkhah, M. S.; Fleck, N. A.; Flintoff, J.; Morris, W. L.; and Xu, J.: A Failure Model for Textile Composites. *Fourth NASA/DoD Advanced Composites Technology Conference*, NASA CP-3229, Part 2, 1993, pp. 705–717.

Progress is reported towards predicting the elastic properties, strength, damage tolerance, and fatigue lives of woven or braided composites with 3-D reinforcement. Composite elastic properties are predicted very well by rules of mixtures corrected for irregularity or waviness in the reinforcement. Strengths can be predicted fairly well by simple micromechanical arguments. Predicting structural failure requires a new computational model. A model called the “Binary Model” is presented for this purpose.

**161.** Cox, B. N.: Fundamental Concepts in the Suppression of Delamination Buckling by Stitching. *Ninth DoD/NASA/FAA Conference on Fibrous Composites in Structural Design—Second NASA ACT Conference*, FAA Report DOT/FAA/CT-92-25.II, pp. 1105–1121.

Elementary results are presented for the buckling of stitched, laminated composites containing delamination cracks. The stitching fibers are assumed to provide continuous, linear restoring tractions opposing the deflection of the delaminated layer adjacent to the crack. Simple expressions are derived for the critical buckling load and the minimum stitching density required to suppress buckling of the delaminated layer. N95-28424

**162.** Cox, B. N.; Carter, W. C.; Dadkhah, M. S.; and Morris, W. L.: *Micromechanics of Fatigue in Woven and Stitched Composites*. NASA-CR-4626.

N95-11246

The goals of this research program were to: determine how microstructural factors control stiffness, strength, and fatigue life in 3-D woven composites, identify mechanisms of failure, model composite stiffness and strength, and model fatigue life. Extensive testing has revealed that these 3-D woven composites possess an extraordinary combination of strength, damage tolerance, and notch insensitivity in compression and tension and in monotonic and cyclic loading.

**163.** Cox, B. N.; Dadkhah, M. S.; Inman, R. V.; Morris, W. L.; and Schroeder, S.: Mechanisms of Compressive Failure in Woven Composites and Stitched Laminates. *Ninth DoD/NASA/FAA Conference on Fibrous Composites in Structural Design—Second NASA ACT Conference*, FAA Report DOT/FAA/CT-92-25.I, pp. 125–138.

N95-28424

Stitched laminates and angle interlock woven composites have been studied in uniaxial, in-plane, monotonic compression. Failure mechanisms have been found to depend strongly on both the reinforcement architecture and the degree of constraint imposed by the loading grips. Stitched laminates display higher compressive strength, but are more brittle than the woven composites.

**164.** Cox, B. N.; Dadkhah, M. S.; Inman, R. V.; Morris, W. L.; and Zupon, J.: Mechanisms of Compressive Failure in 3-D Composites. *Acta Metallurgica et Materialia*, Dec. 1992, pp. 3285–3298.

A93-17402

The present study of angle-interlock woven polymer matrix composite behavior under uniaxial monotonic compression shows these materials to be macroscopically ductile, with compressive failure strains that can exceed 15 percent. Some of the tests conducted on stitched laminates indicated brittle behavior. Woven composite failure mechanisms have been studied by a combination of optical microscopy, Moiré comparisons.

### McDonnell Douglas - Structural Design and Analysis

**165.** Drenth, S. E.; and Renieri, M. P.: Cover Panel and Substructure Design for a Full-Scale Composite Transport Wing. *11th DoD/NASA/FAA Conference on Fibrous Composites in Structural Design—Seventh NASA ACT Conference*. Proceedings are pending.

Results are reported for the design development of full-scale wing cover panels. Key issues are highlighted that govern the use of resin film infused stitched carbon fabric. The integrated design features of the cover panels and substructure development efforts are presented.

**166.** Flanagan, G.; and Furrow, K.: Parametric Studies of Stitching Effectiveness for Preventing Substructure Disbond. *Fifth NASA/DoD Advanced Composites Technology Conference*, NASA CP-3294, Vol. 1, Part 2, 1995, pp. 681–696.

The analysis approach is to treat substructure disbond as a crack propagation problem. Strain-energy-release-rate calculations are performed using a code which uses interconnected higher-order plates to model built-up composite cross-sections. The code, called SUBLAM, is limited to structures that have a constant cross-section in one dimension. A series of tests were performed with specimens incorporating an attached flange such that the sudden change in thickness initiated a delamination. These data were used with the code to predict the load required to delaminate stitched specimens.

**167.** Hawley, A. V.: Detail Design Development of a Transport Aircraft Composite Wing. *Sixth NASA/DoD Advanced Composites Technology Conference*, NASA CP-3326, Vol. 1, Part 1, 1996, pp. 131–154.

Results are reported from the detail design of a 41-foot long semi-span wing structural test box sized for transport aircraft loads. Significant changes have been made to the test box design since the preliminary design was completed. These changes resulted from lessons learned from previous work, i.e., recently available test results, human factors studies, modified design criteria and lower cost fabrication approaches. This paper presents the design changes and the rationale for the changes. FEED restricted until June 30, 1998.

**168.** Hawley, A. V.: Development of Stitched/RTM Primary Structures for Transport Aircraft. NASA CR-191441, 1993.

Results are reported in the development of stitched dry carbon fabric preforms and resin transfer molding (RTM) for application in primary structures of transport aircraft. McDonnell Douglas design criteria and philosophy are discussed as they pertain to wing and fuselage structures. Fabrication of stitched/RTM wing panels is discussed in detail and test data are presented.

**169.** Hawley, A. V.: Preliminary Design of a Transport Aircraft Composite Wing. *Fifth NASA/DoD Advanced Composites Technology Conference*, NASA CP-3294, Vol. 1, Part 2, 1995, pp. 717–771.

The preliminary design, design issues, and design trade-offs for a full-scale composite wing structural box are described. The manufacturing approach selected to achieve weight and cost target improvements makes use of stitched dry carbon fabric preforms and resin film infusion. Fabrication and test of the full-scale box are

expected to provide the technical data required for the application of composite wing structures in new commercial transport aircraft.

**170.** Hawley, A. V.: Preliminary Design of an Advanced Technology Composite Wing for a Transport Aircraft. *Proceedings of the 53rd Annual International Conference of the SAWE*, 1994. Published in SAWE Paper 2235.

A95-17197

The McDonnell Douglas Corporation is developing the technology to allow the incorporation of an all-composite wing on a commercial transport aircraft. This program seeks to combine the performance gains available from composite primary structure with a breakthrough cost reduction from a new manufacturing approach involving the use of dry stitched preforms and resin film infusion (RFI). The discussion in the paper centers on the cover panels since these account for approximately 75 percent of the total wing weight and they will be made using the new manufacturing process.

**171.** Kropp, Y.: Automated Design and Analysis of Bolted Joints for a Composite Wing. *11th DoD/NASA/FAA Conference on Fibrous Composites in Structural Design—Seventh NASA ACT Conference*, 1996. Proceedings are pending.

Results are reported from the development of a new method for predicting the strength of bolted composite joints. The method calculates an effective composite stress at various points around the circumference of a bolt hole and establishes a relationship between calculated stress and the uniaxial material strength obtained from a series of coupon tests. McDonnell Douglas has developed software consisting of the CFAN and BOLTFAST computer programs.

**172.** Page, M.; Sutton, J. O.; and Wakayama, S.: Multi-Disciplinary Optimization of a Composite Wing for a Transport Aircraft Application. *11th DoD/NASA/FAA Conference on Fibrous Composites in Structural Design—Seventh NASA ACT Conference*, 1996. (Proceedings are pending).

A composite wing design for a twin-engine commercial transport aircraft was developed using multi-disciplinary optimization. The wing-tail combination was optimized by automated methods to minimize takeoff weight. In addition to drag, weight, and maximum lift, the following considerations were included in the optimization process: buffet, elastic aileron effectiveness, aircraft weight and balance, terminal gate compatibility, fuel capacity and placement, landing gear storage, and efficient structural manufacturing processes. Because the composite material has less torsional stiffness than

aluminum, elastic aileron effectiveness was found to be a particularly important constraint.

**173.** Sutton, J. O.: A Proposed Method of Compliance to Damage Tolerance Requirements for Commercial Aircraft Composite Primary Wing Structure. *Sixth NASA/DoD Advanced Composites Technology Conference*, NASA CP-3326, Vol. 1, Part 1, 1996, pp. 155–189.

Current Federal Airworthiness Regulations (FARs) call for a specific level of damage tolerance for aircraft structure. The regulations, however, do not specify the actual nature of the damage. For metal structures, abundant historical experience provides confidence in presuming specific sizes and types of representative service damage. For composite structures, historical experience is lacking and the presumed damage state must depend upon analytical reasoning. In this paper, readily reproducible damages are proposed which will produce a conservative simulation of service-related damage. The approach uses two standardized damages which will accurately represent a broad spectrum of real damages likely to occur during commercial airline service. FEDD restricted until June 30, 1998.

#### **McDonnell Douglas - Manufacturing Methods Development**

**174.** Ghumman, A.; and Loos, A. C.: Manufacturing Development and Characterization of the RFI Process Using Analytical Process Models and Dielectric Sensor Technology. *11th DoD/NASA/FAA Conference on Fibrous Composites in Structural Design—Seventh NASA ACT Conference*, 1996. Proceedings are pending.

Results are reported from the development of analytical and numerical process modeling, and dielectric sensors to control and monitor the resin film infusion (RFI) process. In order for the RFI process to be a practical manufacturing process, it is essential to model the resin kinetics and flow, and the preform compaction characteristics. Dielectric sensors that provide “in-situ” information on the state of the resin are used for monitoring the resin kinetics during processing.

**175.** Ghumman, A.; Stewart, T.; Goodwin, S.; and Dexter, H. B.: Characterization and Development of Tri-Axially Braided Stiffeners for Primary Transport Aircraft Wing Structures. *11th DoD/NASA/FAA Conference on Fibrous Composites in Structural Design—Seventh NASA ACT Conference*, 1996. Proceedings are pending.

This paper describes the manufacturing developments that produce high quality and low cost triaxially braided stiffeners that will be used on the stitched/RFI wing covers. McDonnell Douglas selected triaxially braided composite stiffeners because they conform to the highly contoured lower wing cover without buckling or

bulging. Specific developments discussed are: contoured stiffener manufacturing; quality control of the braiding and stitching process; continuous braiding and stitching of triaxially braided stiffeners; and single step stitching for thick complex contoured stiffeners.

**176.** Loos, A. C.; Fingerson, J. C.; and MacRae, J. D.: Verification of a Three-Dimensional RTM/RFI Model. *Technology Transfer in a Global Community—Proceedings of the 28th International Technical Conference*, SAMPE, 1996, pp. 393–403.

This paper presents a discussion of the approach to a model of the RTM/RFI flow process and the results obtained using the model. The model is for use in tool design and process cycle optimization of complex shaped textile preforms. A single blade-stiffened preform was infiltrated in an instrumented mold in an experiment to verify the accuracy of the flow model and the preform permeability measurements. Results of the experiment indicated that the model closely predicted the total time for resin infiltration; however, the model predicted a mold inlet pressure considerably lower than the measured value.

**177.** Loos, A. C.; MacRae, J. D.; Hammond, V. H.; Kranbuehl, D. E.; Hart, S. M.; Hasko, G. H.; and Markus, A. M.: Analytical Modeling and Sensor Monitoring for Optimal Processing of Advanced Textile Structural Composites by Resin Transfer Molding. *Third NASA Advanced Composites Technology Conference*, NASA CP-3178, Part 1, 1993, pp. 361–379.

A two-dimensional model of the resin transfer molding (RTM) process was developed which can be used to simulate the infiltration of resin into an anisotropic fibrous preform. Frequency dependent electromagnetic sensing (FDEMS) has been developed at William and Mary for in situ monitoring of the RTM process. Flow visualization tests were performed to obtain data which can be used to verify the sensor measurements and the model predictions. Results of the tests showed that FDEMS can accurately detect the position of the resin flow-front during mold filling, and that the flow-front patterns predicted with the model agreed well with the measured patterns.

**178.** Loos, A. C.; MacRae, J. D.; Kranbuehl, D. E.; Husmann, C. H.; Rohwer, K. M.; and Deaton, J. W.: Resin Film Infusion (RFI) Process Simulation of Complex Wing Structures. *Fifth NASA/DoD Advanced Composites Technology Conference*, NASA CP-3294, Vol. 1, Part 2, 1995, pp. 811–833.

Results are reported from using a three-dimensional model to simulate the stitched/RFI manufacturing process. The model includes submodels which describe resin flow, heat transfer, preform compaction and resin



kinetics during the RFI process. In a verification experiment, a complex shaped stitched carbon fabric preform was RFI processed and cured in an instrumented mold which allowed monitoring of the resin flow front position and the state of the resin cure. The results indicate the model accurately predicts the thermal behavior of the preform/tooling assembly. Less accuracy was achieved on predicting resin flow behavior.

**179.** Markus, A. M.; and Palmer, R. J.: Resin Transfer Molding for Advanced Composite Aircraft Primary Structures. *First NASA Advanced Composites Technology Conference*, NASA CP-3104, Part 1, 1991, pp. 271–292.

This paper describes the stitched/RFI process in which a resin film is placed on the tool, a stitched carbon fabric preform is placed over the resin, the entire assembly is vacuum bagged and oven cured at 350°F. Resin film infusion (RFI) has been identified by Douglas Aircraft Company as one of the composites processing methods which has the potential for breaking the cost barrier preventing the application of composite primary structures in commercial transports. The expected manufacturing benefits of the stitched/RFI process are discussed using available test data.

**180.** Markus, A. M.; and Grossheim, B. G.: Manufacturing Development of Stitched/RFI Transport Wing Stub Box Structures. *Fifth NASA/DoD Advanced Composites Technology Conference*, NASA CP-3294, Vol. 1, Part 2, 1995, pp. 773–786.

This paper describes the manufacturing approach for an 8-ft. by 12-ft. stub box wing. The wing box is designed for the loads at the side-of-body region of a transport wing. The stub box materials, RFI tooling and assembly tooling are discussed. The wing box is part of a building block approach by McDonnell Douglas Aerospace to develop a materials, manufacturing and cost base for stitched/resin film infusion (RFI) composite structures.

**181.** Markus, A. M.; Rohwer, K. M.; Sutton, J. O.; Thrash, P. J.; and Madan, R. C.: *Fabrication, Analysis Methods and Test Results for Stitched Composite Structures*. NASA CR-191599, 1994.

Results are reported for: structural mechanics of stitched structures, stitching machines for dry carbon fabric preforms, process models for RTM and RFI, wing and fuselage panel tooling and fabrication methods, wing and fuselage panel tests, and fabrication cost data.

**182.** Markus, A. M.: Resin Transfer Molding for Composite Primary Wing and Fuselage Structures. *Ninth DoD/NASA/FAA Conference on Fibrous Composites in Structural Design—Second NASA ACT Conference*, NASA CP-3154, 1992, pp. 141–167. N94-33128

This paper presents stitching/RTM developments, cost analyses and test data obtained by Douglas Aircraft Company under the ACT Program. The findings: RTM/stitching process goals are achievable; high quality preforms with tight tolerances are absolutely necessary; test results on stiffened wing panels show a 16-24 percent increase in post-impact compression strength compared to toughened resins; and process scale-up has been achieved in fabricating 4 ft by 6 ft stiffened wing panels.

**183.** Markus, A. M.; Thrash, P. J.; and Rohwer, K.: Progress in Manufacturing Large Primary Aircraft Structures Using the Stitching/RTM Process. *Third NASA Advanced Composites Technology Conference*, NASA CP-3178, Part 1, 1993, pp. 453–479.

N95-29050

Progress to date by Douglas Aircraft Company is discussed in the area of manufacturing and associated cost values of stitched/RTM composites. For the stitched/RTM wing development, the conclusions are: high quality carbon fabric preforms can be produced using automated stitching equipment; RTM processing works well for complex wing structures; use of RTM resulted in a 50 percent reduction in touch labor vs. prepreg lay-up; and process scale-up to large wing structures is possible.

**184.** Palmer, R. J.; and Freeman, W. T.: Low-Cost Damage-Tolerant Composite Fabrication. *National Technical Specialists' Meeting on Advanced Rotorcraft Structures*, AHS, 1988, p. 15.

A89-29471

A review is presented of methods for fabricating complex shaped composite parts using stitched graphite fabrics to increase damage tolerance, and using resin transfer molding (RTM) to reduce fabrication cost. Stitched graphite fabric composites have demonstrated compression after impact failure performance that equals or exceeds that of thermoplastic or tough thermoset matrix composites.

**185.** Rohwer, K. M.; Markus, A. M.; Wheeler, M.; and Grant, C.: Advanced Tooling Concept Development for Composite Wing Fabrication. *Fifth NASA/DoD Advanced Composites Technology Conference*, NASA CP-3294, Vol. 1, Part 2, 1995, pp. 835–855.

Results are reported from development of an advanced inner mold line (IML) tooling concept (by McDonnell Douglas Aerospace and Hercules, Inc.) for composite wing covers. A discussion is presented of the tooling issues which led to the present development. A description is given of the design and fabrication of the advanced carbon/epoxy IML tooling.

**186.** Rohwer, K. M.; Ghumman, A.; Markus, A. M.; and Polimeno, M.: Stitched/Resin Film Infusion (S/RFI) Manufacturing Technology Development. *11th DoD/NASA/FAA Conference on Fibrous Composites in Structural Design—Seventh NASA ACT Conference*, 1996. Proceedings are pending.

This paper discusses the innovative stitched/resin film infusion (S/RFI) manufacturing process developed to fabricate composite primary wing structures. To date, the S/RFI process has been successfully demonstrated through various transport wing sub-components with the culmination being the fabrication of an 8-ft by 12-ft, integrally stiffened, composite wing stub box. MDA has identified the following specific S/RFI manufacturing technologies for further development: preform detail fabrication and assembly methodology; RFI process control; and RFI sealing and bagging methodology.

#### **McDonnell Douglas - Advanced Stitching Machine Development**

**187.** Markus, A. M.; Miller, J. L.; and Thrash, P. J.: Development of Advanced Automated Stitching Techniques for Carbon Fiber Preform Manufacture. *Technology Transfer in a Global Community—Proceedings of the 28th International Technical Conference*, SAMPE, 1996. (Closed Session)

This paper describes an advanced stitching machine which will be capable of making the preforms for 45-foot long transport wing cover panels. Also, the paper provides a historical perspective and the current status of the stitching technology being developed for complex contoured carbon fiber preforms. For over 10 years McDonnell Douglas has been developing the technology for stitched textile composites for primary aircraft structure applications. Areas of development covered are: stitch type and formation requirements, thick preform stitching, automated stitching equipment and computer controlled stitching hardware.

**188.** Miller, J. L.; and Thrash, P. J.: Fabrication, Assembly and Checkout of an Advanced Stitching Machine. *11th DoD/NASA/FAA Conference on Fibrous Composites in Structural Design—Seventh NASA ACT Conference*, 1996. Proceedings are pending.

This paper describes an advanced stitching machine (ASM) being developed by McDonnell Douglas Aerospace, Ingersoll Milling Machine Company, and Pathe Advanced Composites, Inc. to stitch carbon fiber preforms for transport aircraft wings. In the design of the ASM, special emphasis was given to incorporating elements which automate many of the traditionally manual steps involved in stitching and fabric support. The result of the design effort is a machine specifically designed for

the manufacture of three dimensional carbon fiber preforms. The machine incorporates a combination of modern machine tool elements, computer control systems, and advanced sewing components.

**189.** Thrash, P. J.; and Miller, J. L.: Design of a Stitching Machine for Transport Aircraft Composite Wings. *Sixth NASA/DoD Advanced Composites Technology Conference*, NASA CP-3326, Vol. 1, Part 1, 1996, pp. 191–208.

This paper discusses the advances in stitching technology required in order to achieve the potential of increased damage tolerance and reduced fabrication costs from the stitched/RFI manufacturing process. McDonnell Douglas Aerospace, Ingersoll Milling Machine Co. and Pathe Technologies, Inc. are working to design, build and demonstrate an advanced stitching machine that will be used to assemble integral carbon fabric preforms 50-feet long by 10-feet wide. This paper presents the design and manufacturing requirements for the wing preforms, and the stitching machine requirements and fabrication. FEDD restricted until June 30, 1998.

#### **McDonnell Douglas - Stitched Laminate Test Results**

**190.** Hinrichs, S.; Chen, V. L.; Jegley, D.; Dickinson, L. C.; and Kedward, K. T.: Effect of Impact on Stitched/RFI Compression Panels. *Fifth NASA/DoD Advanced Composites Technology Conference*, NASA CP-3294, Vol. 1, Part 2, 1995, pp. 879–912.

Results are reported from an investigation to determine the effect of different variables (thickness, impact energy and boundary conditions) on the CAI strength of stitched laminates. These data are used to describe the impact damage formation in stitched material and an explanation is given of the effects of impact damage on the compression strength of stitched laminates. A method is proposed for using CAI coupon data to predict the CAI strength of structural panels. A design philosophy is presented for dealing with impact damage in composite structures.

**191.** Hinrichs, S.; Palmer, R. J.; Ghumman, A.; Deaton, J. W.; Furrow, K.; and Dickinson, L. C.: Mechanical Property Evaluation of Stitched/RFI Composites. *Fifth NASA/DoD Advanced Composites Technology Conference*, NASA CP-3294, Vol. 1, Part 2, 1995, pp. 697–716.

This paper presents a summary of mechanical property test data for composite material made using stitched carbon fabrics and resin film infusion. The results are compared to data from conventional tape prepreg composites. The test results show that a multiaxial warp knit preform provides the best properties for wing cover applications.

**192.** Walker, J.; Roundy, L.; and Goering, J.: Effects of Thermal and Moisture Cycling on the Internal Structure of Stitched/RTM Laminates. *Third NASA Advanced Composites Technology Conference*, NASA CP-3178, Part 1, 1993, pp. 415–432.

N95-29048

This paper reports an experimental and analytical investigation in progress at McDonnell Douglas Aerospace in St. Louis to determine causes, effects and possible means to minimize microcracking in stitched laminates. Results are reported from cycling test of stitched laminates. Cracks and voids have been observed at the thread/resin interface in laminates stitched with fiberglass thread. Microscopic examinations reveal two distinct kind of cracks in the resin-rich areas at the thread/resin interface: resin separation cracks and matrix cracks.

#### **McDonnell Douglas and Langley - Structural Tests and Analyses**

**193.** Hinrichs, S. C.; and Kropp, Y.: Analysis and Testing of Stitched/RFI Structural Subcomponents. *11th DoD/NASA/FAA Conference on Fibrous Composites in Structural Design—Seventh NASA ACT Conference*, 1996. Proceedings are pending.

Results are reported from the structural analysis and testing of stitched/RFI wing subcomponents performed by McDonnell Douglas Aerospace. In the composite wing the rib intercostals are stitched and cocured with the cover panel. In order to improve their pull-off and shear strength, special reinforcement was added and evaluated in tests. Also, test results are presented from an access hole tension panel simulating the man-sized access holes in the lower cover, and from a compression repair panel in which the stringer and skin had been severed.

**194.** Hinrichs, S. C.; Kropp, Y.; and Jegley, D. C.: Analysis and Testing of Stitched/RFI Subcomponents. *Sixth NASA/DoD Advanced Composites Technology Conference*, NASA CP-3326, Vol. 1, Part 1, 1996, pp. 209–233.

Results are presented from subcomponent tests performed to provide data for use in the design of a stitched/RFI transport wing. Tests and analyses were performed on several compression and tension subcomponents representative of important design features of the wing covers. The analysis results for the subcomponents are compared with the experimental results and with the composite wing structural requirements. The study conclusions and lessons learned are presented. FEDD restricted until June 30, 1998.

**195.** Hinrichs, S. C.; Madan, R. C.; Voldman, M.; Wu, H-Y.; Jegley, D. C.; and Waters, W. A., Jr.: Analysis and

Test Results from Static Testing of Wing and Fuselage Subcomponents. *Tenth DoD/NASA/FAA Conference on Fibrous Composites in Structural Design*, Report No. NAWCADWAR-94096-60, 1994, Vol. 1, pp. III-47–III-61.

Static test results are reported for wing panels made with the stitched/RFI process and one fuselage panel made by conventional tow placement. One wing panel was constructed with a man-sized access hole which is one of the critical design regions on a composite wing. To simulate discrete source damage, other panels were damaged with various length saw cuts which severed the middle stiffeners and the adjoining skin. The fuselage panel was damaged with a saw cut in a manner similar to the wing panel. The damaged panels carried the design loads.

**196.** Hinrichs, S. C.; Jegley, D. C.; and Wang, J. T.: Structural Analysis and Test of a Stitched Composite Wing Box. *Sixth NASA/DoD Advanced Composites Technology Conference*, NASA CP-3326, Vol. 1, Part 1, 1996, pp. 279–309.

Results are reported from the structural analysis and tests of a stitched composite wing box with a 12-foot span and an 8-foot side-of-body chord. The wing stub was designed for the loads on the inboard portion of a full-scale transport wing torque box. The stub box was designed and constructed by McDonnell Douglas Aerospace; testing was performed by NASA at the Langley Research Center. The upper and lower covers of wing stub box were constructed using the stitched/RFI manufacturing process whereas the substructure components were constructed using conventional composite prepreg materials and processing. The box was designed so that certain important structural features were strength critical. The successful test was a major step in the verification of stitched/RFI wing cover panels for transport aircraft. FEDD restricted until June 30, 1998.

**197.** Jegley, D. C.: *Analysis of Selected Compression Splice-Joint Locations in a Graphite-Epoxy Transport Wing Stub Box*. NASA TM-110170, 1995.

N96-16229

Results are presented from a finite element analysis of three critical compression splice-joint locations in a stitched graphite-epoxy transport wing stub box. The wing box is representative of a section of a commercial transport wing box and was designed and constructed by McDonnell Douglas Aerospace Company as part of the ACT Program. The joints have been analyzed to determine their expected structural performance. The analysis results indicate that failure will not occur in the splice-joint regions for loads less than the Design Ultimate Load of the wing box.

**198.** Jegley, D. C.; and Bush, H. G.: *Test Documentation and Results of the Structural Tests on the All-Composite McDonnell Douglas Wing Stub Box*. NASA TM-110204, 1997.

Results are presented from a series of tests conducted at the Langley Research Center to evaluate the behavior of an all-composite wing box. The wing stub box is representative of a section of a commercial transport aircraft wing box; it was designed and constructed by McDonnell Douglas Aerospace Company as part of the ACT Program. Tests were conducted with and without low-speed impact damage and repairs. The structure with non-visible damage carried 140 percent of Design Limit Load prior to failure through an impact site.

**199.** Jegley, D. C.; and Waters, W. A., Jr.: *Test and Analysis of a Stitched/RFI Graphite-Epoxy Panel with a Fuel Access Door*. NASA TM-108992, 1994.

N94-29100

Results are presented from the test and analysis of a stitched/RFI graphite-epoxy panel with a fuel access door. The panel was initially 56-inches long and 36.75-inches wide and the oval access door was 18-inches long and 15-inches wide. The panel was impact damaged with impact energy of 100 ft-lb prior to compressive loading; however, no impact damage was detectable visually or by A-scan. The panel carried a failure load of 695,000 lb. and global failure strain of .00494 in/in. Finite element analysis indicated the panel would fail due to collapse at a load of 688,100 lb. The test data indicate that the maximum strain in a region near the access door was .0096 in/in and analysis indicates a local surface strain of .010 in/in at the panel's failure load. The panel did not fail through the impact damage, but instead failed through bolt holes for attachment of the access door in a region of high strain.

**200.** Madan, R. C.; and Hinrichs, S. C.: *Fatigue Testing of Stitched/RFI Wing Subcomponents*. *Tenth DoD/NASA/FAA Conference on Fibrous Composites in Structural Design*, Report No. NAWCADWAR-94096-60, Vol. 1, Apr. 1994, pp. II-125–II-150.

Results are reported for wing subcomponent specimens representing critical regions of a composite wing which were tested in spectrum fatigue followed by a static test to failure. The subcomponents tested included: a cover access door, an upper splice joint and a lower cover splice joint. It was observed that the fatigue loading did not degrade the residual strengths of the subcomponents.

**201.** Madan, R. C.; and Voldman, M.: *Test Results from Large Wing and Fuselage Panels*. *Third NASA Advanced*

*Composites Technology Conference*, NASA CP-3178, Part 1, 1993, pp. 481–502.

Test results are presented from wing and fuselage panels made by the Douglas Aircraft Company. A six-stringer wing panel made by using the stitched/RTM process was tested in compression after a 100 ft-lb impact. The panel failure occurred at a strain level which exceeded the requirements for bolted repairs. The fuselage panels were made using conventional tape prepreg processing.

**202.** Sutton, J. O.; Kropp, Y.; Jegley, D.; and Banister-Hendsbee, D.: *Design, Analysis, and Tests of Composite Primary Wing Structural Repairs*. *Fifth NASA/DoD Advanced Composites Technology Conference*, NASA CP-3294, Vol. 1, Part 2, 1995, pp. 913–934.

Results are reported from a test program which demonstrates that stitched/RFI panels with damage can be rapidly restored to the required strength using simple mechanically fastened repairs. McDonnell Douglas Aerospace fabricated several stitched/RFI panels representative of actual wing structure designs and subjected them to various levels of damage. Following demonstrations of the required levels of residual tension and compression strengths, the panels were repaired and subjected to verification testing. A correlation is made of the analytical predictions of residual strength with the panel test results.

**203.** Voldman, M.; Grossheim, B.; and Hayman, E.: *Composite Wing Main Landing Gear Attachment Design, Manufacture and Test*. *11th DoD/NASA/FAA Conference on Fibrous Composites in Structural Design—Seventh NASA ACT Conference*, 1996. Proceedings are pending.

This paper reports on the last phase of the development of a main landing gear (MLG) attachment for a composite wing. The development was concluded in February 1996 with a successful testing of the MLG attachment test article. A short overview is given of the MLG attachment design concept and the analytical methods used to predict test results. The test set-up and the test procedure, as well as the sequence of events during the test, are discussed in detail. A comparison is made between the test results and the analytical predictions.

**204.** Voldman, M.; Wyhowanee, P.; Rohwer, K. M.; Kropp, Y.; and Grossheim, B.: *Design, Analysis, Manufacture and Test of a Stitched, Resin Film Infused Main Landing Gear Attachment Article*. *Sixth NASA/DoD Advanced Composites Technology Conference*, NASA CP-3326, Vol. 1, Part 1, 1996, pp. 233–255.

This paper describes the development and test of a main landing gear (MLG) attachment article. As part of

the McDonnell Douglas Aerospace funded effort in support of the development of stitched/RFI composite wings, a MLG was designed, fabricated and tested. In addition, a new analytical treatment of bolted joints is presented and compared with test data. FEDD restricted until June 30, 1998.

**205.** Wang, J. T.: *Global and Local Stress Analyses of McDonnell Douglas Stitched/RFI Composite Wing Stub Box*. NASA TM-110171, 1996.

Results are reported from the pretest structural analysis of a stitched composite wing box with a 12-foot span and an 8-foot side-of-body chord. McDonnell Douglas Aerospace Company designed the wing stub for the loads on the inboard portion of a full-scale transport wing torque box. Geometrically nonlinear structural responses of the wing stub box were predicted by using the finite element analyses and a global/local approach in which the global model contains the entire test article while the local model contains a large nonlinearly deformed region in the upper cover of the wing stub box. In the global analysis, an upward load was applied at the tip of the box to induce bending. Numerous global and local analysis results such as deformed shapes, displacements at selected locations, and strains at critical locations are included in this report.

**206.** Wang, J. T.; Jegley, D. C.; Bush, H. G.; and Hinrichs, S. C.: *Correlation of Structural Analysis and Test Results for the McDonnell Douglas Stitched/RFI All-Composite Wing Stub Box*. NASA TM-110267, 1996.

Analytical and experimental results are presented for a composite wing stub box with a 12-foot span and an 8-foot side-of-body chord. McDonnell Douglas Aerospace Company designed the wing stub for the loads on the inboard portion of a full-scale transport wing torque box. The wing stub box was fabricated using the stitched/RFI process. For testing, the root end of the stub box was attached to a vertical reaction structure and an upward load was applied to the tip to induce bending. A finite element model was created which represented properly the geometrically nonlinear structural behavior and predicted the strains accurately. The analytical and experimental results for deflections and strains are in good agreement.

**207.** Wang, J. T.; Jegley, D. C.; Bush, H. G.; and Hinrichs, S. C.: *Correlation of Structural Analysis and Test Results for the McDonnell Douglas Stitched/RFI All-Composite Wing Stub Box*. *11th DoD/NASA/FAA Conference on Fibrous Composites in Structural Design*, 1996.

Analytical and experimental results are presented for a composite wing stub box with a 12-foot span and an 8-foot side-of-body chord. McDonnell Douglas Aero-

space Company designed the wing stub for the loads on the inboard portion of a full-scale transport wing torque box. The wing stub box was fabricated using the stitched/RFI process. For testing, the root end of the stub box was attached to a vertical reaction structure and an upward load was applied to the tip to induce bending. A finite element model was created which represented properly the geometrically nonlinear structural behavior and predicted the strains accurately. The analytical and experimental results for deflections and strains are in good agreement.

### ACT Program Overviews

**208.** Chen, V. L.; Hawley, A. V.; Klotzsche, M.; Markus, A. M.; and Palmer, R. J.: *Composites Technology for Transport Primary Structure*. *First NASA Advanced Composites Technology Conference*, NASA CP-3104, Part 1, 1991, pp. 71–126.

The initial plans are presented for the Douglas Aircraft Company (DAC) program “Innovative Composite Aircraft Primary Structures, (ICAPS).” The ICAPS program includes wing and fuselage developments. DAC has decided to focus on composite structures made by stitching dry carbon fabric preforms followed by resin film infusion (RFI) and autoclave curing. Tests show that through-the-thickness stitching provides outstanding damage tolerance in coupons and elements made by the stitched/RFI process.

**209.** Davis, J. G., Jr.: *Advanced Composites Technology Program*. *Third NASA Advanced Composites Technology Conference*, NASA CP-3178, Part 1, pp. 49–78.

A brief overview is presented for the NASA Advanced Composites Technology (ACT) Program. Critical technology issues are identified that must be addressed and solved to develop composite primary structures for aircraft. The program schedule and milestones are presented. Work completed in the first three years of the ACT Program indicates a potential for achieving composite structures that are weight and cost effective compared to conventional aluminum structures. Selected technical accomplishments are noted.

**210.** Davis, J. G., Jr.: *NASA/Advanced Composites Technology*. *Tenth DoD/NASA/FAA Conference on Fibrous Composites in Structural Design*, Report No. NAWCADWAR-94096-60, Vol. I, 1994, pp. IV-1–IV-58.

This paper presents the status and plans of the NASA ACT Program. A summary is made of analysis and design of selected fuselage and wing structural elements under development by Boeing, Lockheed and McDonnell Douglas.

**211.** Davis, J. G., Jr.: Overview of the ACT Program. *Ninth DoD/NASA/FAA Conference on Fibrous Composites in Structural Design—Second NASA ACT Conference*, FAA Report DOT/FAA/CT-92-25, II, pp. 577–599. (NASA CP-3154, June 1992, pp. 3–25).

N94-33121

The NASA Advanced Composites Technology (ACT) Program was started in 1988. A NASA Research Announcement was issued seeking innovative concepts for cost-effective composite primary structures for transport aircraft. Fifteen contracts were awarded by the Spring of 1989 to airframe manufacturers, materials suppliers, universities and government laboratories. An overview is presented of the ACT Program status, plans and selected technical accomplishments.

**212.** Gill, D. R.: Merits of Stitched, Resin Infused, Composite Products. *Technology Transfer in a Global Community—Proceedings of the 28th International Technical Conference*, SAMPE, 1996. (Closed Session)

This overview paper presents a discussion of the stitched/resin film infusion (S/RFI) technology being developed by McDonnell Douglas under contract to NASA. The S/RFI process is explained in detail; the current maturity and limitations of the process are explained. Additional technology needs and the rationale of manufacturing cost projections are discussed.

**213.** Jackson, A. C.: Development of Textiles for Airplane Primary Structures - An Overview. *Sixth NASA/DoD Advanced Composites Technology Conference*, NASA CP-3326, Vol. 1, Part 1, 1996, pp. 77–93.

Lockheed's role in the NASA ACT Program has been the development of textile composite concepts for primary aircraft fuselage structures. Excellent progress has been achieved in the braiding of circumferential frames. Resin transfer molding has been demonstrated as a low-cost manufacturing approach. Powder-coated tow materials appear suitable for weaving and woven reinforcement of window belt structures. FEDD restricted until June 30, 1998.

**214.** Janicki, G. C.; and Gill, D.: Advanced Composites Wing Technology for Future Transport Aircraft. *Sixth NASA/DoD Advanced Composites Technology Conference*, NASA CP-3326, Vol. 1, Part 1, 1996, pp. 1–19.

This paper covers the economic health of the transport industry, cost as the measure of technology merit, and current technology programs. The findings include: attempts to standardize composites acceptance tests have become a fruitless endeavor; reductions in operating cost are essential for new aircraft sales; technology must provide substantial operating advantage without adding to aircraft cost. FEDD restricted until June 30, 1998.

**215.** Kinder, R. H.: Impact of Composites on Future Transport Aircraft. *Third NASA Advanced Composites Technology Conference*, NASA CP-3178, Part 1, 1993, pp. 3–24.

In the economic environment of the 1990s, new technology must be cost effective in addition to improving operability. An easily understood figure of merit and one used by our airline customers is improvement in direct operating cost per seat mile. Sales of new aircraft will go to builders who offer the best economics. Ownership costs will continue to dominate the economics equation. To find application on new transport aircraft, composite primary structures must provide production cost reduction as well as fuel consumption and maintenance benefits.

**216.** Kropp, Y.: Development of a Stitched/RFI Composite Transport Wing. *Mechanics of Textile Composites Conference* (Hampton, VA, Dec. 6-8, 1994). NASA CP-3311, Part 2, 1995, pp. 457–479.

N96-17712

An overview is presented of the program for a composite wing by McDonnell Douglas under NASA contract. The paper describes the key features of the composite wing design and addresses major issues in analysis and manufacturing. The wing is made using a stitched/RFI manufacturing process during which the dry fiber preforms consisting of several stacks of warp-knit material are stitched together, impregnated with resin and cured. The stitched/RFI wing skin panels have exceptional damage tolerance and fatigue characteristics, are easily repairable, and can carry higher gross stress than their metal counterparts.

**217.** Palmer, R. J.: Techno-Economic Requirements for Composite Aircraft Components. *Fiber-Tex 1992—Sixth Conference on Advanced Engineering Fibers and Textile Structures for Composites*, NASA CP-3211, 1993, pp. 305–341.

In this paper, the author discusses the cost and weight benefits textile composite offer for aircraft applications. Present and future aircraft applications are discussed and the critical technical and cost issues are addressed. A brief review is made of the Douglas Aircraft Company's stitched preform/resin film infusion approach to low-cost manufacturing.

## Other Textile Composites Research

### Mechanics of Materials and Structures

**218.** Adams, D. O.: *Idealized Textile Composites for Experimental/Analytical Correlation*. Hampton University, 1994 NASA-HU American Society for Engineering

Education (ASEE) Summer Faculty Fellowship Program, p. 57.

N95-23277

Due to random architectures of textile composites, the experimental data obtained have been of limited use for verifying the accuracy of analytical models and codes. Results are presented from research focused on woven textile composites with highly aligned and accurately placed fiber tows that closely represent the idealized nesting architectures assumed in analytical models. Compression testing results have identified strength variations as a function of nesting.

**219.** Adams, D. O.; Brieling, K. B.; and Verhulst, M. A.: Effects of Nesting on Compression-Loaded 2-D Woven Textile Composites. *Mechanics of Textile Composites Conference*, NASA CP-3311, Part 1, 1995, pp. 5–31.

Layer nesting, usually assumed in analysis models, was investigated in textile composite laminates under static compression loading. Laminates were fabricated with three idealized nesting cases: stacked, split-span and diagonal. Similar strength reductions due to the effects of idealized nesting were observed for each material.

**220.** Camponeschi, E. T., Jr.; and Crane, R. M.: A Model for the Fiber Geometry and Stiffness of Multidirectional Braided Composites. *3-D Composite Materials*, NASA CP-2420, 1986, pp. 75–89.

Results are reported from research to develop a model for the fiber geometry in braided composites in terms of the braiding parameters and to develop a laminate stiffness model using the fiber geometry and plate theory. This work was performed at the David Taylor Naval Ship Research and Development Center.

**221.** Cholakara, M. T.; Jang, B. Z.; and Wang, C. Z.: Deformation and Failure Mechanisms in 3-D Composites. *Tomorrow's Materials: Today—Proceedings of the 34th International Symposium and Exhibition*, Vol. 34, Book 2, SAMPE, 1989, pp. 2153–2160.

A90-31641

Test results show that through-the-thickness stitching increases interlaminar shear strength and fracture toughness in composite laminates. Observations were made of the failure mechanisms occurring under different types of static and dynamic loading. The mechanical behavior of the composites was studied with tests of short beam shear, impact fatigue, and 3-point bending fatigue.

**222.** Dransfield, K.; Baillie, C.; and Mai, Y-W.: On Stitching as a Method for Improving the Delamination Resistance of CFRPs. *Advanced Composites '93—Proceedings of the International Conference on*

*Advanced Composite Materials (ICACM)*, Minerals, Metals & Materials Society, 1993, pp. 351–357.

A95-40842

Stitching is a method by which through-the-thickness reinforcement can be introduced into conventional composite laminates. Relevant literature on stitched composites is reviewed and the advantages and disadvantages of stitching are identified. Results show that the extent to which the mechanical properties of the composite laminate are affected by stitching is dependent on both the stitching and testing parameters, and on the fabrication techniques.

**223.** Du, G.-W.; Popper, P.; and Chou, T.-W.: Analysis and Automation of Two-Step Braiding. *Fiber-Tex 1988—Second Conference on Advanced Engineering Fibers and Textile Structures for Composites*, NASA CP-3038, 1989, pp. 217–233.

A description is presented of a mathematical model developed for the structural geometry of 3-D braids made by the two-step process. The model relates the process variables with the structural features of the fabric preform. Model predictions demonstrated excellent agreement with experiments on rectangular slabs. Also described is a new concept for automating the process by motorized braiding carriers moving on a special track.

**224.** Fowser, S.; and Wilson, D.: Analytical and Experimental Investigation of 3-D Orthogonal Graphite/Epoxy Composites. *3-D Composite Materials*, NASA CP-2420, 1986, pp. 91–108.

Results are reported from an investigation of the analytical, numerical and experimental behavior of orthogonal fabric composites. The numerical work consists of 3-D finite element analysis of a unit cell of the fabric to determine in-plane and out-of-plane elastic properties. Using composites made with two different fabric geometries tests were performed to measure mechanical properties, fiber volume fraction and fracture energy release rates.

**225.** Jang, B. Z.; and Chung, W. C.: Structure-Property Relationships in Three Dimensionally Reinforced Fibrous. *Advanced Composites: The Latest Developments—Proceedings of the Second Conference*, ASM Int., 1986, pp. 183–191.

A88-18241

The deformation and failure processes in 3-D composites were investigated. Samples of 3-D composites were prepared by stitching third direction fibers through two-dimensional fabrics or prepreg layers. Third direction fibers were found to be very effective in inhibiting delamination and arresting propagating cracks in

composites. Deformation and failure mechanisms were studied using the techniques of *in situ* light microscopy and scanning electron microscopy.

**226.** Lei, C. S.; and Ko, F. K.: A Strength Theory for Failure of 3-D Braided Composites. *Material and Process Challenges: Aging Systems, Affordability, Alternative Applications—41st International Symposium and Exhibition*, Book 1, SAMPE, 1996, pp. 443–449.

A methodology is presented for strength consideration of 3-D braided composites under general loading conditions. A mechanics of materials approach is used to adopt a fabric geometry model for strength prediction. Iso-strain and iso-stress models are used to determine the strength of 3-D braids with various failure criteria.

**227.** Liao, D.; Tan, T. M.; and Ko, F. K.: Compressive Behavior of 3-D Braided Composites Part I, Experimental Observations. *How Concept Becomes Reality—36th International Symposium and Exhibition*, Book 1, SAMPE, 1991, pp. 114–128.

The role of fiber material properties and fiber architecture on the compressive behavior of 3-D braided composites was examined in terms of compressive modulus, compressive strength, Poisson's ratio and fractography. Results from experiments show that compressive modulus is dominated by material properties whereas compressive strength was highly sensitive to the percentage of longitudinal fibers in the composite.

**228.** Liu, D.: Photoelastic Study on Composite Stitching. *Experimental Techniques*, vol. 14, 1990, pp. 25–27.

A90-26056

In addition to mechanical bolting and adhesive bonding methods, fiber-reinforced composite fabrics can also be stitched together. From the experimental results presented the following conclusions are drawn: (1) it is possible to use photoelasticity to study the efficiency of the stitching technique in composite joining, (2) the stress-optic coefficient can be used as an indicator of joining rigidity, (3) the ratio of the stress-optic coefficient in a nonuniform area to that in a uniform area can be used as an indicator of composite damage or stitching efficiency, and (4) the residual stress increases as the joining rigidity increases.

**229.** Mohajerjasbi, S.: Modeling and Analysis of 4-Step 3-D Cartesian Braided Composites. *10th DoD/NASA/FAA Conference on Fibrous Composites in Structural Design*, NAWCADWAR-94096-60, Vol. 1, Apr. 1994, pp. II-3–II-22.

A finite element based method is proposed for modeling the structure of a 3-D braided composite and deter-

mining its thermoelastic constants. The method treats without smearing the fiber and matrix as distinct elements constituting two separate models. The model of the braided composite is obtained by superposition of the fiber and resin models.

**230.** Norman, T. L.; Allison, P.; Baldwin, J. W.; Gracias, B. K.; and Seesdorf, D.: Effect of Tow Alignment on the Mechanical Performance of 3-D Woven Textile Composites. *Fiber-Tex 1992—Sixth Conference on Advanced Engineering Fibers and Textile Structures for Composites*, NASA CP-3211, 1993, pp. 97–113.

Results are presented from a study comparing the mechanical properties of uniform and nonuniform angle interlock 3-D weave constructions. The effect of adding layers of laminated tape to the outer surfaces of the textile preform was examined. Damage mechanisms were investigated and test methods were evaluated.

**231.** Pastore, C. M.; Bogdanovich, A. E.; Kumar, V.; and German, M.: 3-D Stress Analysis in Textile Composite Plates Using a Combination of ANSYS and Sub-Element/Deficient Approximation Function Analysis. *Advanced Composites X—10th Annual ASM/ESD Advanced Composites Conference*, ASM International, 1994, pp. 389–399.

A95-36790

Three dimensional stress calculations for textile composites are improved by incorporating a novel 3-D Sub-Element/Deficient Approximation Function (SEDAF) analysis in commercial finite element codes. Using SEDAF in combination with commercial finite element codes (using the SEDAF analysis as a post-processor) seems to be a promising option for improving the local stress predictions in textile composite structural parts. The methodology proposed is demonstrated in this paper.

**232.** Redman, C. J.; and Douglas, C. D.: Theoretical Prediction of the Tensile Elastic Properties of Braided Composites. *Advanced Materials: Performance Through Technology Insertion—Proceedings of the 38th International Symposium and Exhibition*, Book 1, SAMPE, 1993, pp. 719–727.

This paper reports the development of a theoretical model which predicts the tensile elastic properties of tri-axially braided composites. The model uses the rule of mixtures and classical lamination theory. The braid is separated into its three components and the stiffness of each is analyzed separately; then, the individual stiffnesses are combined to provide a braid stiffness.



**233.** Tsai, G. C.: Global/Local Stress Analysis of Stitched Composite Laminate. *Advanced Materials/Affordable Processes—Proceedings of the 23rd International Technical Conference*, SAMPE, 1991, pp. 297–312.

A92-51523

The problem of using 3-D finite element analysis to investigate the stitching thread effect on the stress distribution of composite laminates is addressed. The thread was modified to be the 3-D spar element in the finite element model. The effect of the stitched pattern on the stress distribution was studied in depth. The results showed that the stitched thread only contributes in the local stress and did not affect the global stress distribution.

**234.** Tsai, J. S.; Li, S. J.; and Lee, L. J.: Performing Analysis and Mechanical Properties of Composite Parts Made from Textile Preform RTM. *Material and Process Challenges: Aging Systems, Affordability, Alternative Applications—Proceedings of the 41st International Symposium and Exhibition*, Book 2, SAMPE, 1996, pp. 1230–1237.

A geometrical model has been developed describing the relationship among fiber orientation, local fiber volume fraction, and RTM mold geometry. The model prediction is compared with preforming experiments based on a plain weave fabric and a box shaped mold. A micro-mechanics model is applied to predict the strength of composite tubes made of braided fiber preforms and RTM processed.

**235.** Whitney, T. J.; Chou, T.; Taske, L.; and Majidi, A. P.: Performance Maps of 3-D Textile Structural Composites. *Fiber-Tex 1987—First Conference on Advanced Engineering Fibers and Textile Structures for Composites*, NASA CP-3001, Part 1, 1988, pp. 153–167.

A model has been developed to predict the inplane properties of 3-D textile structural composites. The usefulness of the model, however, depends on knowledge of the actual fiber bundle locations after consolidation. The model appears to serve as a qualitative lower bound on axial modulus and a qualitative upper bound on Poisson's ratio.

### Manufacturing Studies

**236.** Bennett, G.; Rais-Rohani, M.; Hall, K.; Holifield, W.; Sullivan, R.; and Brown, S.: Rapid Prototyping of Composite Aircraft Structures. *SAE—General, Corporate & Regional Aviation Meeting and Exposition*, SAE Paper 931219, 1993.

A94-14121

The use of computer graphics and a 5-axis gantry robotic router are among the more recent elements incorporated by the present research laboratory-scale implementation of a rapid prototyping system for experimental and unmanned aircraft structures derived from wet lay-up/autoclave-cured composites. Stitched-reinforcement composite preforms and resin-transfer molding techniques are currently being explored. The structural configuration of the aircraft in question must be established within the framework of concurrent engineering, through detailed analysis and design optimization.

**237.** Brookstein, D. S.: A Comparison of Multilayer Interlocked Braided Composites with Other 3-D Braided Composites. *How Concept Becomes Reality—Proceedings of the 36th International Symposium and Exhibition*, Book 1, SAMPE, 1991, pp. 141–150.

During the 1980s, two distinctly different methods were developed for producing 3-D braided preforms. These methods were the track and column or four-step, and the two-step processes. Both processes use discrete non-continuous braider movements. This paper details a new 3-D braiding process which has the capability to produce layer-to-layer interlocking with or without axial yarns.

**238.** Brookstein, D. S.: Interlocked Fiber Architecture: Braided and Woven. *Advanced Materials: The Challenge for the Next Decade—Proceedings of the 35th International Symposium and Exhibition*, Book 1, SAMPE, 1990, pp. 746–756.

Braided and woven fabric preforms are widely used as reinforcement media in composite structures. Traditionally these preforms are configured as two-dimensional planar lamina and have severe limits to their ability to transfer interlaminar stresses. This paper provides some interlocking method alternatives which generate fiber interconnections between layers yet do not substantially reduce the amount of fiber remaining in the plane of each lamina.

**239.** Brown, R. T.: 3-D Braiding: From the Laboratory to the Factory. *3-D Composite Materials*, NASA CP-2420, 1986, pp. 271–288.

Atlantic Research and other companies have made prototype structural preforms using 3-D weaving but the methods are not mature. Weaving 3-D preforms is a high risk venture which desperately needs a clearly defined aerospace application for the technology.

**240.** Brown, R. T.; and Crow, E. C., Jr.: Automatic Through the Thickness Braiding. *Materials Working for You in the 21st Century—Proceedings of the 37th*

*International Symposium and Exhibition, SAMPE, 1992*, pp. 832–842.

This paper summarizes the state-of-the art and approaches to braider actuation and control. The authors illustrate techniques by describing the fabrication of complex structural shapes such as I-beams, ribs, and blade stiffened panels.

**241.** Cai, Z.; and Berdichevsky, A. L.: Influence of Fiber Packing Structure on Permeability. *Fiber-Tex 1992—Sixth Conference on Advanced Engineering Fibers and Textile Structures for Composites*, NASA CP-3211, 1993, pp. 167–181.

Results are presented from a study of the variation of permeability of a fiber bundle under practical processing conditions. Fiber bundles are considered as containing openings and fiber clusters within the bundle. Numerical simulations on the influence of various openings on the permeability were conducted.

**242.** Crawford, J. A., Jr.: Recent Developments in Multi-directional Weaving. *3-D Composite Materials*, NASA CP-2420, 1986, pp. 259–269.

A discussion is presented of the multidirectional weaves which can be made with existing technology and the benefits and limitations of each weave type.

**243.** Drummond, T.: Automated Near-Net Preform Manufacturing for Resin Transfer Molding. *Fiber-Tex 1990—Fourth Conference on Advanced Engineering Fibers and Textile Structures for Composites*, NASA CP-3128, 1991, pp. 135–142.

An automated preform manufacturing machine has been developed which shows promise for the composites industry. The features of the machine are explained and the cost benefits expected from its use are discussed.

**244.** Drummond, T.; and Krasnitz, R.: Advanced Stitching Technology for the Composite Industry. *Fiber-Tex 1989—Third Conference on Advanced Engineering Fibers and Textile Structures for Composites*, NASA CP-3082, 1990, pp. 141–160.

With sketches, summary information is given on stitch types, stitching machine bed styles, material feeding systems, types of needles, and a comparison of the attributes of lock stitching vs. chain stitching.

**245.** Harris, H.; Schinske, N.; Krueger, R.; and Swamson, B.: Multiaxial Stitched Preform Reinforcements for RTM Fabrication. *Technology Transfer in a Global Community—Proceedings of the 36th International Symposium and Exhibition*, Book 1, SAMPE, 1991, pp. 521–535.

A discussion is presented of the uses and the benefits of preforms which incorporate stitched unidirectional fibers. Particular attention is given to the improvement in compression after impact properties and the manufacturing and the design flexibility with the use of unidirectional stitched preforms. Labor costs of the stitched preforms/resin transfer molding process are compared to the traditional autoclave process.

**246.** Hess, J. P.: Two-Dimensional Braided Composite Materials and Structures. *Fiber-Tex 1989—Third Conference on Advanced Engineering Fibers and Textile Structures for Composites*, NASA CP-3082, 1990, pp. 199–202.

A brief summary is made of the attributes of braiding and its potential application in aircraft structures.

**247.** Hotz, L. E.: Application of Quilting and Stitching Technology. *Fiber-Tex 1989—Third Conference on Advanced Engineering Fibers and Textile Structures for Composites*, NASA CP-3082, 1990, pp. 161–166.

This paper presents a thumbnail history of stitching and the evolution of the stitching machine. Modern lock and chain stitching fundamentals are discussed using figures.

**248.** Hunston, D.; Phelan, F.; and Parnas, R.: Flow Behavior in Liquid Molding. *Fiber-Tex 1991—Fifth Conference on Advanced Engineering Fibers and Textile Structures for Composites*, NASA CP-3176, 1992, pp. 23–42.

This paper briefly outlines a National Institute of Standards and Technology (NIST) program in liquid molding (LM) and presents several examples to illustrate the work. LM includes both resin transfer molding and reaction injection molding. The NIST program includes materials characterization, process models, on-line process monitoring and control, and the fabrication of test specimens.

**249.** Kaufmann, J. R.: Industrial Applications of Multi-axial Warp Knit Composites. *Fiber-Tex 1991—Fifth Conference on Advanced Engineering Fibers and Textile Structures for Composites*, NASA CP-3176, 1992, pp. 77–86.

This paper examines the industrial applications of multi-axial warp knit fabrics. Also included in the paper is a discussion of fabric properties.

**250.** Ko, F. K.: Manufacturing, Structure, and Properties of Multi-axial Warp Knit Composites. *Fiber-Tex 1989—Third Conference on Advanced Engineering Fibers and Textile Structures for Composites*, NASA CP-3082, 1990, pp. 173–187.

A92-10165

This paper examines the nature of the family of warp knit fabrics covering a range of structural geometry and stress strain response. To provide a basis for design and analysis, a fabric geometry model was derived and experimentally verified. Based on the model, design curves are given for warp knit fabrics.

**251.** Ko, F. K.; and Pastore, C. M.: Design and Formation of 3-D Fabrics for Advanced Composites. *3-D Composite Materials*, NASA CP-2420, 1986, pp. 207–227.

Design and fabrication methods are reviewed for making 3-D carbon fabrics. It is demonstrated that computer-aided design is an effective means to define the internal geometry of laminates, form the structural shapes and relate processing parameters to composite properties.

**252.** Kranbuehl, D. E.; Hood, D. O.; Rogozinski, J.; Limburg, W.; Loos, A. C.; and MacRae, J.: Smart Manufacturing for Resin Transfer Molding of Advanced Fiber Architecture Preforms. *9 emes Journees Nationales sur les Composites* (Saint-Etienne, France, Nov. 1994). *Mater. Tech. (Paris)* 80, Nov.-Dec. 1994, pp. 18–22.

Resin transfer molding (RTM) of stitched preforms is being developed as a smart cost-effective manufacturing technique for composite structures. Dry textile preforms are infiltrated with resin and cured in a single step process. In-situ cure monitoring sensors and an analytical processing model are a superior alternative for the determination of optimum processing cycles, quality assurance and automated process control.

**253.** LaMattina, B.; and Parvizi-Majidi, A.: The Fabrication and Processing of 3-D Woven Composites Using Resin Transfer Molding. *Advanced Materials/Affordable Processes—Proceedings of the 23rd International Technical Conference*, SAMPE, 1991, pp. 870–884.

Results are reported from a study of angle interlock weaving and resin transfer molding of composites. These composites exhibit improved impact and delamination resistance over traditional 2-D fabric composites. The weave parameters that govern preform geometry and fiber architecture are discussed.

**254.** Lynch, T.: The Fabrication of Low-Cost Structural Shapes for Composite Reinforcement. *3-D Composite Materials*, NASA CP-2420, 1986, pp. 251–257.

Angle interlock braiding is described and is identified as having the potential to accurately position carbon fibers, minimize fiber damage, and reduce labor costs. The author makes a plea for new concepts and machines for making 3-D preform weaves.

**255.** Maiden, J. R.; and Ebersole, T. S.: Development of Composite Structures with Enhanced Damage

Tolerance. *Advanced Materials/Affordable Processes—Proceedings of the 23rd International Technical Conference*, SAMPE, 1991, pp. 855–869.

A92-51555

A novel approach has been developed for damage-tolerant composite structures which applies existing textile technology to an interply stitching system which enhances a laminate's ability to withstand out-of-plane loading. The stitching mechanism interlocks multiple noncrimped fabric layers, and has been designated the 'mock-stitched woven' fiber architecture. By using stitching yarn that is independent of the in-plane carbon fabric, the in-plane reinforcing fibers are not impaled and in-plane properties are not degraded. The process has been verified to be applicable to various fiber diameters and moduli.

**256.** Morales, A.: Design Methodology of 3-D Woven Structures. *Advanced Materials/Affordable Processes—Proceedings of the 23rd International Technical Conference*, SAMPE, 1991, pp. 913–921.

A review is presented of a novel computer-aided design methodology for 3-D woven fabrics. With this design tool, the 3-D woven preform can be designed directly on the computer screen whereon 3-D representations of the yarns within the fabric are transformed directly into weaving patterns.

**257.** Munjal, A. K.; and Maloney, P. F.: Braiding for Improving Performance and Reducing Manufacturing Costs of Composite Structures for Aerospace Applications. *Advanced Materials: Looking Ahead to the 21st Century—Proceedings of the 22nd International Technical Conference*, SAMPE, 1990, pp. 1231–1242.

This paper discusses how braiding can be used to improve performance and reduce manufacturing costs of composite structures. Braiding is compared to other manufacturing methods namely filament winding, manual and automated tape lay-up, tape winding and pultrusion in terms of versatility, reproducibility, quality and manufacturing cost.

**258.** Palmer, R. J.: 3-D Composite Materials: Resin Impregnation Process. *3-D Composite Materials*, NASA CP-2420, 1986, pp. 289–293.

A cursory description is presented of the patented resin impregnation process developed by Douglas Aircraft Company for consolidating thick layers of carbon fabric.

**259.** Palmer, R. J.; and Curzio, F.: Cost-Effective Damage-Tolerant Composites Using Multi-Needle Stitching and RTM/VIM Processing. *Fiber-Tex 1988—Second Conference on Advanced Engineering Fibers and Textile*

*Structures for Composites*, NASA CP-3038, 1989, pp. 25–52.

A manufacturing process is described that includes (1) a semi-automated weaving/stitching operation of dry layers of carbon fabric to produce a near net shape preform, (2) resin vacuum impregnation molding and (3) in-tool curing in an autoclave. The manufacturing process is projected to both lower the cost of composites fabrication and produce structural elements with significantly improved damage tolerance.

**260.** Redman, C. J.; and Douglas, C. D.: Theoretical Prediction of the Tensile Elastic Properties of Braided Composites. *Advanced Materials: Performance Through Technology Insertion—Proceedings of the 38th International Symposium and Exhibition*, Book 1, SAMPE, 1993, pp. 719–727.

This paper reports the development of a theoretical model which predicts the tensile elastic properties of triaxially braided composites. The model uses the rule of mixtures and classical lamination theory. The braid is separated into its three components and the stiffness of each is analyzed separately; then, the individual stiffnesses are combined to provide a braid stiffness.

**261.** Scardino, F. L.: Advanced Stitching Technology. *Fiber-Tex 1991—Fifth Conference on Advanced Engineering Fibers and Textile Structures for Composites*, NASA CP-3176, 1992, pp. 11–22.

Fabric preforms can be made by stitching together several layers of yarn at various angles or plies of skewed fabric. The major advantages of multi-axial stitched-through fabric preforms are high density, control of yarn orientation and integration of layers. The major disadvantage is the loss of strength from impaling the yarns during stitching.

**262.** Schooneveld, G. Van: Potential of Knitting/Stitching and Resin Infusion for Cost-Effective Composites. *Fiber-Tex 1988—Second Conference on Advanced Engineering Fibers and Textile Structures for Composites*, NASA CP-3038, 1989, pp. 113–131.

Textile manufacturing methods are available for cost-effective and damage tolerant composites. The key to success is assembling the reinforcements dry via textile processing. Resin infusion and near-net processing minimize material waste and subsequent processing steps.

**263.** Shim, S. B.; Ahn, K.; Seferis, J. C.; Berg, A. J.; and Hudson, W.: Cracks and Microcracks in Stitched Structural Composites Manufactured with Resin Film Infusion Process. *J. Adv. Mater.*, vol. 26, no. 4, July 1995, pp. 48–62.

Stitched structural composites were fabricated to study cracking in resin-rich areas as well as microcracking in the intralaminar regions. Recent material developments have included homogeneous toughened resin systems and new bendable stitching fibers. The study focused on examining various epoxy resin matrices introduced by the resin film infusion process into stitched unidirectional carbon fiber or woven reinforcements. Microcracking mechanisms were identified and related to the stitching fibers used.

**264.** Slotte, S. G.; Karbhari, V. M.; and Wilkins, D. J.: Effect of Fiber Architecture on Performance and Manufacturability of RTM Parts. *Advanced Materials/Affordable Processes—Proceedings of the 23rd International Technical Conference*, SAMPE, 1991, pp. 900–912.

This paper presents the results of a study on the effects of a variety of fiber architectures on the performance and manufacturability of a stiffened plate. The stiffener was formed of two foam cores with reinforcement around each, and embedded within a stamped preform. The implications of the findings are examined in the context of a full-scale prototype.

**265.** Steenkamer, D. A.; Wilkins, D. J.; and Vistasp, M. K.: Strategies for Designing Multi-Element Preforms for RTM. *Advanced Materials/Affordable Processes—Proceedings of the 23rd International Technical Conference*, SAMPE, 1991, pp. 885–899.

This paper addresses the issue of preform joining. The major drawback to the use of RTM stems from the inability of the preforming process to form net shapes. These limitations often dictate a decomposition of the structure into sections that can be preformed satisfactorily. However, these multi-element sections must be joined to provide load path continuity.

**266.** Weller, R. D.: AYPEX: A New Method of Composite Reinforcement Braiding. *3-D Composite Materials*, NASA CP-2420, 1986, pp. 111–124.

This paper describes the development of adjacent yarn position exchange (AYPEX) as a basic approach to the braiding of composite preform fabrics. AYPEX has the potential to permit braiding patterns not previously possible within the geometry of structures and to promote a new family of braiding machines.

**267.** Zawislak, S. P.; and Maiden, J. R.: Advanced Weaving Concepts for Complex Structural Preforms. *Fiber-Tex 1988—Second Conference on Advanced Engineering Fibers and Textile Structures for Composites*, NASA CP-3038, 1989, pp. 91–111.

Significant advances are reported in weaving technology for structural composite reinforcement. It is dem-

onstrated that structural preforms can be used to enhance damage tolerance, provide near-net shape reinforcement and reduce fabrication costs. A comprehensive glossary of textile terms is included.

### Experimental Studies

**268.** Avery, J. G.; Allen, M. R.; Sawdy, D.; and Avery, S.: Survivability Characteristics of Composite Compression Structure. *Eighth DoD/NASA/FAA Conference on Fibrous Composites in Structural Design*. NASA CP-3087, Part 2, 1990, pp. 455–478.

Test and evaluation were performed to determine the compression residual capability of graphite reinforced composite panels following perforation by high-velocity fragments representative of combat threats. Several fiber/matrix systems were investigated including high-strain fibers, tough epoxies, and APC-2 thermoplastic. Additionally, several laminate configurations were evaluated including hard and soft laminates and the incorporation of buffer strips and stitching for improved damage resistance and tolerance. The evaluation generally showed small differences in the responses of the material systems tested. The soft laminate configurations with concentrated reinforcement exhibited the highest residual strength. N92-32578

**269.** Billaut, F.: Mechanical Behavior of 3-D Graphite/Epoxy Composites. *American Society for Composites—Proceedings of the 9th Technical Conference*, Technomic Publ. Co., Inc., 1994, pp. 223–230.

A95-20826

Results are reported from an experimental study of two stitched laminates and two kinds of angle-interlock architectures in which the interlacement occurs between adjacent layers. The effects on the mechanical properties of the various architecture characteristics such as the stitch density and the fiber undulation were investigated in tension, in-plane shear, and interlaminar shear tests. Stitching did not affect the in-plane elastic constants whereas a decrease of 20-35 percent in modulus was observed for the interlocks. All the through-the-thickness reinforcements had a detrimental effect on the tensile strength.

**270.** Chan, W. S.; and Dan-Jumbo, E.: A Comparison of the Structural Behavior of Laminates Made of Knitted Nonwoven Fabric and Laminates Made of Conventional Unidirectional Tapes. *Proceedings of the 31st International SAMPE Symposium and Exhibition*, SAMPE, 1986, pp. 1154–1165.

A87-13136

The structural properties of AS4/3501-6 nonwoven fabric laminates were evaluated and are compared with conventional AS4/3501-6 tape laminates. The nonwoven fabric consists of unidirectional roving fibers knitted together with polyester thread into plies. The plies are then stacked at the desired angles and stitched with Kevlar thread to form laminates. In general, the test results indicate that nonwoven fabric laminates are comparable to conventional tape laminates in damage tolerance and energy-absorption capability, but are inferior in ultimate strength and fatigue life.

**271.** Chang, C-W.; and Young, W-B.: Experimental Investigation on Blade-Stiffened Panel with Stiffener-to-Skin Fiber Stitching. *AIAA J.*, vol. 34, no. 9, Sep. 1996, pp. 1964–1966.

Results are reported from an investigation of the reinforcing effect of stiffener-to-skin stitching on flat blade-stiffened composite panels. Several types of stitching configurations were tested to evaluate the influence of stitching. Test results showed that stitching both the stiffener blade and the flange increased the failure pull-off load by about 25 percent. A96-36775

**272.** Du, X.; Xue, F.; and Gu, Z.: Experimental Study of the Effect of Stitching on Strength of a Composite Laminate. *International Symposium on Composite Materials and Structures*, Technomic Publ. Co., Inc., 1986, pp. 912–918.

A86-50203

Test results demonstrate that stitching a laminate will increase its interlaminar shear strength. However, the laminate's in-plane strength may be degraded to some extent by the stitching. Results are presented from both tension tests of unidirectional reinforced laminates and compression tests of quasi-isotropic specimens. The loss of in-plane strength is observed to be due to fiber breakage induced by the stitching process itself.

**273.** Gause, L. W.; and Alper, J. M.: Buckling and Crippling Behavior of Braided Composite Shapes. *3-D Composite Materials*, NASA CP-2420, 1986, pp. 143–170.

Results are reported from mechanical tests of aircraft structural shapes made from braided composites. The tests have been used to establish strength, stiffness, buckling stability, and stiffener pull-off loads. The braided materials provided major improvements in stiffener pull-off loads compared to conventional laminate constructions.

**274.** Herrick, J. W.; and Dexter, H. B.: Impact Resistance of Multidirectional Graphite/Epoxy Composites. *3-D Composite Materials*, NASA CP-2420, 1986, pp. 111–124.

A review is presented of post-impact residual strength data for 3-D and 4-D composites. The 3-D material had fibers in the three major directions, x, y, and z whereas the 4-D composites had fibers in the three major directions, x, y, and z plus fibers through-the-thickness.

**275.** Jang, B. Z.; Shih, W. K.; and Chung, W. C.: Mechanical Properties of Multidirectional Fiber Composites. *J. Reinf. Plast. & Compos.*, vol. 8, Nov. 1989, pp. 538–564.

A90-16087

Results are reported from an evaluation of structure-property relationships in both 3-D and 2-D composites. In particular, the influence of the stitched through-the-thickness fibers on mechanical behavior was investigated. The stitching fibers effectively reduce the extent of delamination by increasing the interlaminar surface energy. The third directional fibers are found to have a profound effect on the failure mechanisms.

**276.** Kwon, Y. S.: Performance of 3-D Textile Composites in Bolted Joints. *Fifth NASA/DoD Advanced Composites Technology Conference*, NASA CP-3294, Vol. 1, Part 2, 1995, pp. 635–647.

Data are presented on the behavior of bolted joints constructed using four types of 3-D textile composites: through-the-thickness braided; through-the-thickness woven; multi-axial warp knitted and multi-layer woven. Bolt bearing capacities and failure modes are presented for single and double lap shear specimens. Also presented are data on the effects of simultaneous bearing and bypass loading, and the resistance to fastener push-through.

**277.** Liu, D.: Delamination in Stitched and Nonstitched Composite Plates Subjected to Low-Velocity Impact. *American Society for Composites—Technical Conference, 2nd*, Technomic Publ. Co., Inc., 1987, p. 147–155.

A88-39662

The potential of delamination in a composite laminate subjected to low-velocity impact is hypothesized by the mismatching of bending stiffness between the laminae on both sides of an interface. The effects due to the material property, stacking sequence, and thickness on the delamination have been investigated. Specimens with through-the-thickness stitching have been tested and the results show the importance of stitching in improving delamination resistance.

**278.** Munjal, A. K.: Damage Tolerance Improvement Approaches for Composite Components. *Proceedings of the American Helicopter Society*, 1988, pp. 931–938.

A89-18927

This paper presents various damage-tolerant designs, materials, and manufacturing/processing approaches for composite components, with emphasis on impact tolerance. Particular attention is given to the optimization of composite lay-up (i.e., fiber orientation, stacking sequence) and damage containment using stitching, interleaving, three-dimensional reinforcements, hybrid concepts, and the use of external protection materials. Material factors discussed include the effects of strength, modulus, strain to failure, fracture toughness, and environmental resistance. The discussion includes the importance of optimal cure cycles and cure temperature in manufacturing damage-resistant composites.

**279.** Pelstring, R. M.; and Madan, R. C.: Stitching to Improve Damage Tolerance of Composites. *Tomorrow's Materials: Today—Proceedings of the 34th International Symposium and Exhibition*, Vol. 34, Book 2, SAMPE, 1989, pp. 1519–1528.

A90-31606

Through-the-thickness stitching is evaluated for the improvement of damage tolerance. An effort is made to correlate the toughness characteristics of stitched panels to stitching parameters, and analytical techniques for the prediction of damaged structure failure under conditions of static and impact loadings. Stitching is shown to limit the damage area caused by impact by arresting delamination and furnishing a low-energy path for matrix cracking, as well as by preventing delamination growth in static compression-after-impact loading.

**280.** Ratwani, M. M.: Impact of Composite Materials on Advanced Fighters. *17th National SAMPE Technical Conference—SAMPE Proceedings*, 1985, p. 232–241.

A86-21722

This paper presents a discussion of the impact of composite materials on the performance, durability and life cycle costs of advanced fighter aircraft. The advantages of using high strain fibers, high toughness resin and hybrids in the structural design of advanced composites are discussed. Stitching has an important role in retarding delamination growth in composites.

**281.** Shu, D.; and Mai, Y-W.: Effect of Stitching on Interlaminar Delamination Extension in Composite Laminates. *Composites Science and Technology*, vol. 49, no. 2, 1993, pp. 165–171.

A94-12331

Results are presented from an investigation of the influence of stitching on the buckling of and delamination extension in laminates. It was assumed that the stitches follow a Winkler elastic foundation type of stress-separation relation. Delamination extension is

governed by the Griffith fracture criterion in which the total elastic strain energy release rate,  $G$ , calculated from the sum of contributions from bending, axial compression, stitching and residual axial compression exceeds the fracture toughness,  $G_c$ , of the matrix material. The results obtained show that stitching can significantly increase the strength of composite laminates under edge-wise compression.

**282.** Stinchcomb, W.; Simonds, R. A.; and Jones, R. M.: Mechanical Behavior of Braided Composites. *3-D Composite Materials*, NASA CP-2420, 1986, pp. 125–141.

Results are reported from tests of braided laminates made by Milliken and Company of Spartanburg, South Carolina. Test data are presented for tensile and compressive strength and stiffness of the Milliken braid, and its fatigue life and stiffness when subjected to fully reversed fatigue loading.

**283.** Tan, T. M.; Sun, C. T.; and Mignery, L. A.: The Use of Stitching to Suppress Delamination in Laminated Composites. *Delamination and Debonding of Materials—Proceedings of the American Society for Testing and Materials*, 1985, pp. 371–385.

Results are reported from an investigation of the effect of stitching on edge delamination and ultimate strength in graphite/epoxy laminates. The results show that stitching effectively arrests delamination, but has varying effects on tensile strength. A two-dimensional finite element is used to calculate interlaminar normal stress and strain energy release rate for stitched and unstitched laminates. The introduction of stitching causes little change in interlaminar normal stress. However, it reduces the strain energy release rate as the delamination crack approaches the stitch line.

A86-20643

### Fatigue Studies

**284.** Cholakara, M. T.; Jang, B. Z.; and Wang, C. Z.: Deformation and Failure Mechanisms in 3-D Composites. *Tomorrow's Materials: Today—Proceedings of the 34th International Symposium and Exhibition*, Book 2, SAMPE, 1989, pp. 2153–2160.

A90-31641

Through-the-thickness stitching increased interlaminar shear strength and fracture toughness in composite laminates. The failure mechanisms occurring under different types of static and dynamic loading were investigated in this paper. Short beam shear test, impact fatigue test, and 3-point bending fatigue tests were conducted to study the mechanical behavior of the composites.

**285.** Moon, D. G.: Characterization and Prediction of Post-Impact Fatigue Damage in Stitched Composites. Ph.D. Thesis, Clemson Univ., South Carolina, 1993.

N95-30826

The post-impact fatigue response of stitched carbon/epoxy composite materials was characterized and modeled in this investigation. Five composite laminate configurations were evaluated. Four laminates were made using cross-ply layers of carbon fabric which were reinforced by dense arrays of through-the-thickness stitches at 8 penetrations per inch in rows spaced at 1/4, 3/16, or 1/8 inches. Of these four laminates, three were consolidated using a conventional brittle epoxy resin whereas the fourth was made with an advanced toughened epoxy resin. For test comparison purposes, the fifth laminate was unstitched and consolidated using the brittle resin. Statistical analysis of the undamaged compressive properties shows no strength penalty from the stitching. Compared to the unstitched laminate, stitching reduced the elastic moduli and increased the compression strains. All the post-impact fatigue coupons displayed stable damage growth with the stitched laminates developing narrow damage zones transverse to the loading direction. The propagation of these narrow zones is empirically predicted with a non-dimensional parameter,  $P$ , which allows the post-impact fatigue data to be correlated with an exponential damage growth model.

**286.** Moon, D. G.; and Kennedy, J. M.: Predicting Post-Impact Damage Growth and Fatigue Failures in Stitched Composites. *American Society for Composites—Proceedings of the 9th Technical Conference*, Technomic Publ. Co., Inc., 1994, pp. 991–998.

Models were devised for the post-impact fatigue failure and damage growth response of stitched carbon/epoxy panels. Laminates with four stitch densities were evaluated. All the post-impact panel specimens developed stable damage growth emanating from the damage site during fatigue loading. While circular delaminations are known to elongate into ellipses in unstitched samples, the stitched samples propagated narrow damage zones transverse to the loading direction. Experimental data are used to predict panel failure. A95-20905

**287.** Moon, Darwin G.; and Kennedy, John M.: Post-Impact Fatigue Response of Stitched Composites. *Composite materials: Fatigue and Fracture—Fifth Volume: 5th Symposium*, ASTM Special Technical Publ., No. 1230, 1995, pp. 351–367.

A96-14354

The post-impact fatigue response of stitch-reinforced carbon/epoxy composite materials was evaluated. Five different material configurations (all based on a 48-ply

quasi-isotropic laminate), three stitch densities (penetrations per unit area), and two resins were used in the study. For baseline comparison purposes, an unstitched baseline laminate was also evaluated. Although the lightly stitched toughened resin material had the best fatigue performance, a highly stitched brittle system behaved almost as well. The current generation of stitched material was found to provide twice the fatigue load-carrying capability of the baseline unstitched laminate.

**288.** Wolterman, R. L.; Kennedy, J. M.; and Farley, G. L.: Fatigue Damage in Thick, Cross-Ply Laminates with a Center Hole. *1993 Composite Materials—Fatigue and Fracture*, vol. 4, ASTM, 1993, pp. 473–490.

A94-19023

Results are reported from tests of thick cross-ply laminates made using AS/4 carbon fabric and a brittle matrix with and without stitching; and a tough-matrix material. Quasi-static tension and compression tests were conducted on specimens with and without circular holes to determine strength, modulus, and failing strain. Results showed that the measured static mechanical properties were insensitive to the type of matrix material because the laminate response was dominated by the 0 degree fibers. The stitched specimens had significantly lower static compressive strengths. A series of fatigue tests (tension-tension, compression-compression, and tension-compression) showed that the matrix material and stitching influenced the fatigue behavior of the composite.

## Overviews and Summaries

**289.** Munjal, A. K.: Damage Tolerance Improvement Approaches for Composite Components. *44th Annual American Helicopter Society Forum*, AHS, 1988, pp. 931–938.

A89-18927

The paper presents various damage-tolerant designs, materials, and manufacturing approaches for composite components, with emphasis on impact damage tolerance. Particular attention is given to the optimization of composite lay-ups, and to damage containment using stitching, interleaving, three-dimensional reinforcements, hybrid concepts, and external protection materials. The discussion includes material factors such as strength, modulus, strain to failure, fracture toughness, and environmental resistance.

**290.** Piellisch, R.: Weaving an Aircraft. *Aerosp. America*, vol. 30, Feb. 1992, p. 54, 55.

A92-24911

Composites manufacturing technologies under development by NASA's Advanced Composite Technology program are essential to the commercialization of composite primary structures for aircraft. The technologies include several advanced fiber placement methods (3-D weaving, advanced braiding, through-the-fabric stitching, and textile preforms). Efforts are being made to harness the most highly automated techniques of the textiles industry to create near-net-shape preforms and, thus, to obtain major reductions in labor costs compared to conventional laminate composite lay-ups.



## Author Index

	Entry		Entry
A			
Adams, D. O. . . . .	218, 219	Chen, V. L. . . . .	56, 190, 208
Adams, L. T. . . . .	143	Cholakara, M. T. . . . .	221, 284
Adams, L. T., Jr. . . . .	136	Chou, T. . . . .	235
Ahn, K. . . . .	263	Chou, T.-W. . . . .	16, 223
Allen, L. E. . . . .	1	Chou, T-W. . . . .	140
Allen, M. R. . . . .	268	Chu, R. L. . . . .	132, 133, 136, 145
Allison, P. . . . .	230	Chung, W. C. . . . .	225, 275
Alper, J. M. . . . .	273	Clarke, S. . . . .	2
Ambur, D. R. . . . .	54	Claus, S. J. . . . .	81, 82
Anglin, C. . . . .	49	Clyburn, E. . . . .	109
Avery, J. G. . . . .	268	Coats, T. W. . . . .	111
Avery, S. . . . .	268	Cox, B. N. . . . .	157, 158, 159, 160, 161, 162, 163, 164
B			
Baillie, C. . . . .	222	Coxon, B. R. . . . .	15
Baldwin, J. W. . . . .	230	Crane, R. M. . . . .	220
Banister-Hendsbee, D. . . . .	202	Crawford, J. A., Jr. . . . .	242
Barrie, R. E. . . . .	136, 143, 144, 145, 148, 149	Crow, E. C., Jr. . . . .	240
Baucom, R. M. . . . .	146	Curzio, F. . . . .	259
Bayha, T. D. . . . .	133, 141, 146, 150	D	
Bennett, G. . . . .	236	Dadkhah, M. S. . . . .	157, 160, 162, 163, 164
Berdichevsky, A. L. . . . .	241	Dan-Jumbo, E. . . . .	270
Berg, A. J. . . . .	263	Dastin, S. . . . .	156
Bernardon, E. . . . .	4	Davis, H. . . . .	133
Billaut, F. . . . .	269	Davis, J. G., Jr. . . . .	120, 209, 210, 211
Birger, A. B. . . . .	109	Deaton, J. W. . . . .	31, 32, 56, 178, 191
Black, K. . . . .	40	Delbrey, J. . . . .	33
Bogdanovich, A. E. . . . .	22, 90, 97, 231	Dellinger, G. . . . .	92
Bohon, H. L. . . . .	120	Dexter, H. B. . . . .	31, 34, 35, 52, 54, 57, 65, 66, 83, 89, 121, 122, 123, 124, 125, 126, 175, 274
Brieling, K. B. . . . .	219	Dickinson, L. C. . . . .	58, 59, 93, 190, 191
Brookstein, D. S. . . . .	237, 238	Dorris, W. J. . . . .	134, 139
Brown, R. T. . . . .	239, 240	Douglas, C. D. . . . .	232, 260
Brown, S. . . . .	236	Dow, M. B. . . . .	60, 61, 62, 68, 70
Burr, S. T. . . . .	30	Dow, N. F. . . . .	94, 95, 96
Bush, H. G. . . . .	198, 206, 207	Dransfield, K. . . . .	222
Buttitta, C. . . . .	153, 154	Drenth, S. E. . . . .	165
Bynum, J-H. . . . .	140	Drummond, T. . . . .	243, 244
C			
Cai, Z. . . . .	241	Du, G.-W. . . . .	223
Camponeschi, E. T. . . . .	126	Du, X. . . . .	272
Camponeschi, E. T., Jr. . . . .	220	Dzenis, Y. A. . . . .	97
Cano, R. J. . . . .	35, 55, 66	E	
Carter, W. C. . . . .	157, 160, 162	Ebersole, T. S. . . . .	255
Chan, W. S. . . . .	270	Edie, D. D. . . . .	1
Chang, C-W. . . . .	271	Egensteiner, W. A. . . . .	155
Chang, F. K. . . . .	116	Eichinger, D. . . . .	85
Chen, P. . . . .	91	Eichinger, D. A. . . . .	82
		Einarson, M. . . . .	15

	Entry
El-Messery, M. ....	39
El-Shiekh, A. ....	9, 13, 14, 39, 40, 43, 44, 75, 91, 104, 117
Ewen, J. R. ....	152

F

Fahmy, A. A. ....	118
Falcone, A. ....	62
Farley, G. L. ....	5, 63, 64, 288
Fedro, M. J. ....	3, 15, 21, 23, 36, 45
Feldman, S. M. ....	155
Fingerson, J. C. ....	176
Flanagan, G. ....	98, 166
Fleck, N. A. ....	160
Flintoff, J. ....	160
Foley, M. F. ....	4
Fowser, S. ....	224
Foye, R. L. ....	46, 92, 99, 100
Freeman, W. T. ....	184
Freeman, W. T., Jr. ....	127
Funk, J. G. ....	57, 65
Furrow, K. ....	98, 166, 191
Furrow, K. W. ....	37, 38, 55, 66

G

Gause, L. W. ....	273
German, M. ....	231
Ghumman, A. ....	174, 175, 186, 191
Gill, D. ....	214
Gill, D. R. ....	212
Glaessgen, E. H. ....	101
Goering, J. ....	192
Goodwin, S. ....	6, 175
Gowayed, Y. A. ....	46, 102
Gracias, B. K. ....	230
Grant, C. ....	185
Griffith, O. H., Jr. ....	101
Grossheim, B. ....	203, 204
Grossheim, B. G. ....	180
Gu, Z. ....	272
Gunther, C. ....	36
Gunther, C. K. ....	23

H

Hairr, J. W. ....	134
Hall, K. ....	236
Hammad, M. ....	9, 39, 43, 44
Hammond, V. H. ....	86, 87, 177
Hardee, H. ....	75
Hardee, H. A. ....	40

	Entry
Harris, C. E. ....	111, 125, 128, 129
Harris, H. ....	245
Hart, S. ....	85
Hart, S. M. ....	87, 177
Hartness, J. T. ....	6, 146
Hartranft, D. ....	16
Hasko, G. H. ....	34, 35, 83, 86, 87, 89, 177
Hawley, A. V. ....	167, 168, 169, 170, 208
Hayman, E. ....	203
Henstenburg, R. B. ....	94
Herrick, J. W. ....	274
Hess, J. P. ....	246
Hinrichs, S. ....	190, 191
Hinrichs, S. C. ....	193, 194, 195, 196, 200, 206, 207
Holifield, W. ....	236
Hood, D. ....	84
Hood, D. O. ....	252
Hotz, L. E. ....	247
Huang, J. T. ....	134
Hudson, W. ....	263
Huey, C. O., Jr. ....	5
Hugh, M. K. ....	6, 7, 145, 146
Hunston, D. ....	248
Husmann, C. H. ....	178
Hyer, M. W. ....	103

I

Ifju, P. G. ....	15, 17, 21, 22, 45
Ingram, J. E. ....	133, 134
Inman, R. V. ....	163, 164

J

Jackson, A. C. ....	135, 136, 147, 148, 149, 213
Jackson, W. C. ....	41, 42, 50, 71
Jang, B. Z. ....	221, 225, 275, 284
Janicki, G. C. ....	214
Jegley, D. ....	190, 202
Jegley, D. C. ....	194, 195, 196, 197, 198, 199, 206, 207
Johnston, N. J. ....	6, 7, 125, 145, 146
Johnston, P. H. ....	105
Jones, R. M. ....	282

K

Kang, T. J. ....	117
Karbhari, V. M. ....	264
Kaufmann, J. R. ....	8, 249
Kedward, K. T. ....	190
Kennedy, J. M. ....	286, 288
Kennedy, John M. ....	287
Kinder, R. H. ....	215

	Entry
Kingsley, P. ....	85
Kinsley, P. J. ....	88
Klotzsche, M. ....	208
Knott, T. W. ....	103
Ko, F. K. ....	36, 226, 227, 250, 251
Kranbuehl, D. ....	85
Kranbuehl, D. E. ....	82, 84, 86, 87, 88, 177, 178, 252
Krasnitz, R. ....	244
Kropp, Y. ....	171, 193, 194, 202, 204, 216
Krueger, R. ....	245
Kullerd, S. M. ....	32, 56, 67, 68, 105
Kumar, V. ....	231
Kuykendall, M. A. ....	137
Kwon, Y. S. ....	136, 139, 276

### L

LaMattina, B. ....	253
Lee, H. H. ....	103
Lee, L. J. ....	234
Lee, S. ....	116
Leger, C. A. ....	143
Lei, C. S. ....	226
Levy, D. ....	85
Li, S. J. ....	234
Li, W. ....	9, 43, 44, 104
Liao, D. ....	227
Lickfield, G. C. ....	1
Limburg, W. ....	84, 252
Liu, D. ....	228, 277
Long, E. R., Jr. ....	88, 105
Loos, A. C. ....	66, 81, 82, 84, 85, 86, 87, 88, 89, 174, 176, 177, 178, 252
Lubowinski, S. J. ....	61, 69
Lynch, T. ....	254

### M

MacRae, J. ....	84, 252
MacRae, J. D. ....	87, 176, 177, 178
Madan, R. C. ....	56, 181, 195, 200, 201, 279
Madaras, E. I. ....	105
Mai, Y-W. ....	222, 281
Maiden, J. ....	123
Maiden, J. L. ....	64
Maiden, J. R. ....	7, 255, 267
Majidi, A. P. ....	235
Maloney, P. F. ....	257
Marchello, J. M. ....	6, 7, 145, 146
Markus, A. M. ....	87, 177, 179, 180, 181, 182, 183, 185, 186, 187, 208

	Entry
Marrey, R. V. ....	113
Masters, J. E. ....	15, 18, 19, 20, 21, 22, 26, 27, 28, 45, 46, 47, 50, 71, 80
Maynard, S. J. ....	131
McCollum, J. R. ....	1
Mignery, L. A. ....	283
Miller, J. I. ....	189
Miller, J. L. ....	187, 188
Minguet, P. J. ....	23, 47, 48
Mohajerjasbi, S. ....	229
Mohamed, M. H. ....	10, 118
Moon, D. G. ....	285, 286
Moon, Darwin G. ....	287
Morales, A. ....	2, 11, 12, 256
Morris, D. H. ....	30, 80
Morris, W. L. ....	157, 160, 162, 163, 164
Munjal, A. K. ....	257, 278, 289

### N

Naik, R. A. ....	47, 106, 107
Norman, T. L. ....	49, 230

### O

Osborne, P. P. ....	146, 151
Ott, L. M. ....	136

### P

Page, M. ....	172
Palmer, R. J. ....	70, 179, 184, 191, 208, 217, 258, 259
Parnas, R. ....	248
Parvizi-Majidi, A. ....	140, 253
Pastore, C. ....	12
Pastore, C. M. ....	22, 46, 97, 102, 108, 109, 231, 251
Peebles, L. ....	126
Pelstring, R. M. ....	279
Phelan, F. ....	248
Piellisch, R. ....	290
Pochiraju, K. ....	140
Poe, C. C., Jr. ....	15, 50, 69, 71, 72, 80, 110, 111, 128, 129
Polimeno, M. ....	186
Popper, P. ....	223
Portanova, M. ....	29
Portanova, M. A. ....	20, 24, 25, 26, 27, 28, 32, 41, 42, 50, 51, 71, 72
Pravizi-Majidi, A. ....	16
Puckett, P. M. ....	131

	Entry
R	
Rais-Rohani, M. ....	236
Raju, I. S. ....	112
Ramnath, V. ....	95, 96
Ratwani, M. M. ....	280
Redman, C. J. ....	232, 260
Reeder, J. R. ....	73, 74
Reid, R. ....	14, 40, 44
Reid, R. L. ....	75
Renieri, M. P. ....	165
Reyzer, M. ....	85
Rives, J. S. ....	13
Rogozinski, J. ....	84, 252
Rohwer, K. ....	183
Rohwer, K. M. ....	178, 181, 185, 186, 204
Roundy, L. ....	192

	Entry
S	
Sankar, B. V. ....	50, 76, 77, 78, 79, 113, 114, 115
Sawdy, D. ....	268
Scardino, F. L. ....	261
Schinske, N. ....	245
Schooneveld, G. Van ....	262
Schroeder, S. ....	163
Sean, M. H. ....	88
Seesdorf, D. ....	230
Seferis, J. C. ....	263
Shah, B. H. ....	136
Shah, B. M. ....	116, 134, 138, 139, 140, 148, 149
Shahid, I. ....	116
Sharma, S. ....	76, 77
Sharma, S. K. ....	78, 79
Shih, W. K. ....	275
Shim, S. B. ....	263
Shu, D. ....	281
Shukla, J. G. ....	6, 133, 136, 141, 142, 145, 148, 149, 150, 151
Simonds, R. A. ....	282
Skolnik, D. Z. ....	136, 143, 144, 149, 151
Slotte, S. G. ....	264
Smith, B. T. ....	64
Smith, D. L. ....	52, 60, 61, 70
Smith, L. V. ....	53
Sobel, L. H. ....	155
Sonik, V. ....	114, 115
Srirengan, K. ....	119
Steenkamer, D. A. ....	265
Stein, B. A. ....	124
Stewart, T. ....	175

	Entry
Stinchcomb, W. ....	282
Suarez, J. ....	156
Suarez, J. A. ....	152, 153, 154, 155
Sullivan, R. ....	236
Sun, C. T. ....	283
Sutton, J. O. ....	172, 173, 181, 202
Swamson, B. ....	245
Swanson, S. R. ....	53

	Entry
T	
Tan, T. M. ....	227, 283
Taske, L. ....	235
Thaxton, C. ....	14
Thrash, P. J. ....	181, 183, 187, 188, 189
Thrasher, T. P. ....	146
Tsai, G. C. ....	233
Tsai, J. S. ....	234

	Entry
V	
Vandermey, N. E. ....	80
Verhulst, M. A. ....	219
Vistasp, M. K. ....	265
Voldman, M. ....	195, 201, 203, 204

	Entry
W	
Wakayama, S. ....	172
Walker, J. ....	192
Walker, T. H. ....	111
Wang, C. Z. ....	221, 284
Wang, J. T. ....	112, 196, 205, 206, 207
Waters, W. A., Jr. ....	195, 199
Wei, L. ....	117
Weideman, M. H. ....	82, 83, 88, 89
Weller, R. D. ....	266
Wheeler, M. ....	185
Whitcomb, J. ....	119
Whitcomb, J. D. ....	72
Whitney, T. J. ....	235
Wigent, D. E. ....	118
Wilkins, D. J. ....	264, 265
Willden, K. ....	3
Williamson, A. ....	85
Wilson, D. ....	224
Wilson, D. W. ....	130
Wolterman, R. L. ....	288
Woo, E. P. ....	131
Wu, H-Y. ....	195
Wu, S. Y. ....	142, 150, 151
Wyhowanee, P. ....	204

	Entry		Entry
		X	
Xu, J. ....	160		
Xue, F. ....	272		
		Y	
Young, W-B. ....	271		
			Z
		Zawislak, S. P. ....	267
		Zhang, Z. ....	10
		Zupon, J. ....	164

## REPORT DOCUMENTATION PAGE

*Form Approved*  
OMB No. 0704-0188

Public reporting burden for this collection of information is estimated to average 1 hour per response, including the time for reviewing instructions, searching existing data sources, gathering and maintaining the data needed, and completing and reviewing the collection of information. Send comments regarding this burden estimate or any other aspect of this collection of information, including suggestions for reducing this burden, to Washington Headquarters Services, Directorate for Information Operations and Reports, 1215 Jefferson Davis Highway, Suite 1204, Arlington, VA 22202-4302, and to the Office of Management and Budget, Paperwork Reduction Project (0704-0188), Washington, DC 20503.

<b>1. AGENCY USE ONLY</b> <i>(Leave blank)</i>	<b>2. REPORT DATE</b> November 1997	<b>3. REPORT TYPE AND DATES COVERED</b> Technical Publication	
<b>4. TITLE AND SUBTITLE</b> Development of Stitched, Braided and Woven Composite Structures in the ACT Program and at Langley Research Center (1985 to 1997) <i>Summary and Bibliography</i>		<b>5. FUNDING NUMBERS</b> WU 538-10-11-02	
<b>6. AUTHOR(S)</b> Marvin B. Dow and H. Benson Dexter			
<b>7. PERFORMING ORGANIZATION NAME(S) AND ADDRESS(ES)</b> NASA Langley Research Center Hampton, VA 23681-2199		<b>8. PERFORMING ORGANIZATION REPORT NUMBER</b> L-17662	
<b>9. SPONSORING/MONITORING AGENCY NAME(S) AND ADDRESS(ES)</b> National Aeronautics and Space Administration Washington, DC 20546-0001		<b>10. SPONSORING/MONITORING AGENCY REPORT NUMBER</b> NASA TP-97-206234	
<b>11. SUPPLEMENTARY NOTES</b> Dow: Distinguished Research Associate, Langley Research Center, Hampton, VA; Dexter: Langley Research Center, Hampton, VA.			
<b>12a. DISTRIBUTION/AVAILABILITY STATEMENT</b> Unclassified-Unlimited Subject Category 24 Distribution: Standard Availability: NASA CASI (301) 621-0390		<b>12b. DISTRIBUTION CODE</b>	
<b>13. ABSTRACT</b> <i>(Maximum 200 words)</i> Summary results are presented from the research conducted on woven, braided, knitted and stitched (textile) composites at the Langley Research Center and under the NASA Advanced Composites Technology (ACT) Program in the period from 1985 to 1997. The report also includes an annotated bibliography of 270 U.S. publications on textile composites (with their abstracts). Two major research areas are discussed: (1) the general research in textile composites performed throughout the period under the direction of the Langley Research Center and (2) the development of textile composite aircraft structures by industry under the NASA ACT Program. The annotated bibliography is organized in three subsections: (1) general textiles R&D under the auspices of Langley, (2) ACT Program development of textile structural components, and (3) textiles research by individuals and organizations not associated with the ACT Program. An author index is provided for the reports and documents.			
<b>14. SUBJECT TERMS</b> Textiles; Composites; Stitching; Braiding		<b>15. NUMBER OF PAGES</b> 86	<b>16. PRICE CODE</b> A05
<b>17. SECURITY CLASSIFICATION OF REPORT</b> Unclassified	<b>18. SECURITY CLASSIFICATION OF THIS PAGE</b> Unclassified	<b>19. SECURITY CLASSIFICATION OF ABSTRACT</b> Unclassified	<b>20. LIMITATION OF ABSTRACT</b>