

Development of Building Heat Detection System: An Improvement Study

M. F. Sulaima¹, Foo Jia En¹, W. M. Bukhari¹, M. H. Jali¹, T. A. Izzuddin¹

¹ Faculty of Electrical Engineering, Universiti Teknikal Malaysia Melaka, 76100, Hang Tuah Jaya, Malacca, Malaysia

ABSTRACT- The increment of the numbers for accidents due to building safety system errors has created a serious disaster over the year. Due to that reason, this paper presents the entitled Building Heat Detection System (BHD System) by the objectives to develop the proper circuit in order to secure the detection device during the building fire attack. A BHD system, also known as fire protection system consists of heat sensing and monitoring system. The sensors detect extreme heat in an area or zone; the control unit processes the signals and sets off evacuation alarms to alert building occupants. This study focused on the design and fabrication of the system prototype to demonstrate the operation of a BHD system in case of fire accidents. Hose reel indicator is included to display the exact location in a building to aid in firefighting. On top of that, exit indicators were added to show the available exits should fire breaks out in a building. This study is hoped to help the system engineers to improve and secure their building safety system in the future.

Keywords: Building heat detection system, fire alarm, fire protection system

I. INTRODUCTION

Through the years, fire accidents have taken numerous lives and led many people homeless. In the earlier half of year 2012, Malaysia's Fire and Rescue Department had reported a total number of 15,360 fire incidents in Malaysia. These incidents had led to 49 deaths and a total property loss of about 0.3 billion MYR [1]. As these statistics were presented, a fire protection system becomes the key in reducing casualties and property losses.

The existing BHD system is made up of two subsystems: a heat detection system and a monitoring system. A heat detection system is capable of sensing the extreme temperature in a specific area or zone; the control cabinet acts as a monitor to relay the sensor information and provide early warning to building occupants [2-4]. However, this system does not display the available exits in a building during the incident. Besides that, firefighting becomes tougher as the hose reel is sometimes located in a hidden corner.

By looking at this system, it can be seen that improvements are vital in increasing the effectiveness of evacuation process. And thus, this study does not only aim at designing and fabricating an existing BHD system prototype, it also serves the purpose of enhancing the conventional system by adding exit and hose reel indicator in the building. As it is impossible to cover all types of buildings, therefore this system will only be demonstrated in a mock building based on the Faculty of Electrical Engineering in Universiti Teknikal Malaysia Melaka (UTeM).

II. FIRE ALARM SYSTEM AND HEAT SENSOR

A fire alarm system is a complex system that performs technical detection and processes, runs and maintains the safety of a building [5-7]. According to [8-10], a well-designed safety fire control system must detect fire before it becomes critical and provide early warning to evacuate people. A fire alarm system detects heat and/or smoke and sends the output to the control cabinet [11-12]. The following are some examples of the existing fire alarm system in the market. From [13], Mitron M900 is a microprocessor-based multiplex type control cabinet. This system comes with a direct linkage to the nearest fire brigade station. The system is designed such that when any sensor detects extreme heat change, the signal will be sent to the control panel and processed by the microprocessor. The alarm and

indicator will be set off to provide evacuation warning. The Sinteso Fire Control FC2060 is a microprocessor based control panel that processes various detectors signals. This device is also capable of monitoring faults occurred in the detectors [14]. Apart from that, Johnson controls intelligent fire alarm has introduced the product that is capable of identifying the specific locations of each detector as well as its activity. This fire alarm control system can be modified in terms of number of sensors to cater users' needs [15].

A heat detector, also known as temperature detector consists of a fixed resistor and a thermistor [11, 16]. When the surrounding temperature increases, the resistance of the thermistor decreases [17-19]. Thermistors are used in the heat sensor often because it is small and responds faster. However, it is not suitable for larger range and does not exhibit linearity in resistance versus temperature graph.

III. METHODOLOGY

To design an improved version the BHD system, the system operation as shown in Figure 1 was considered.

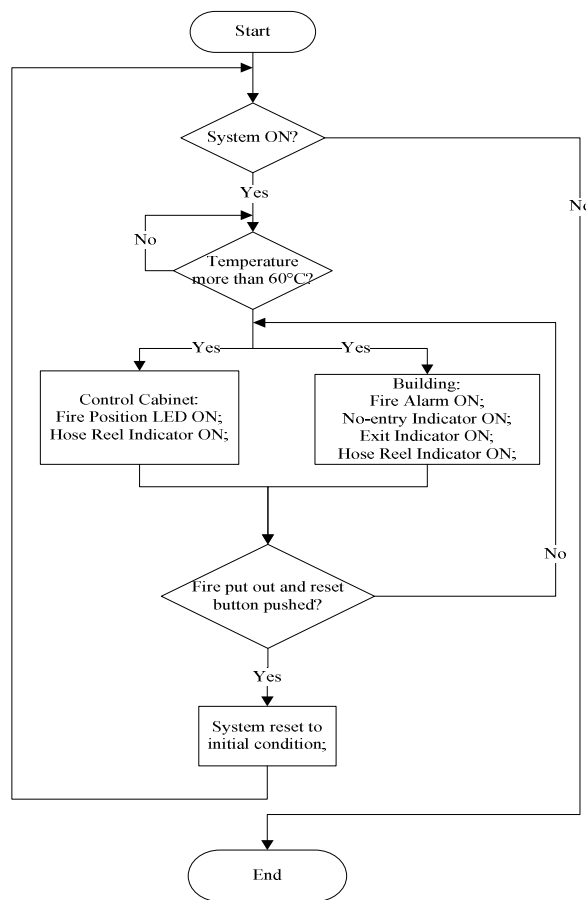

Figure 1: Flowchart of the BHD system operation.

The circuit design was divided into two parts: a sensor circuit and a control circuit. As the project only focused on producing a prototype of this system, thus a NTC thermistor is used to substitute the actual heat sensor in a BHD system as it is part of the components in heat detectors. The completed sensor circuit can be observed from Figure 2.

Development of Building Heat Detection System: An Improvement Study

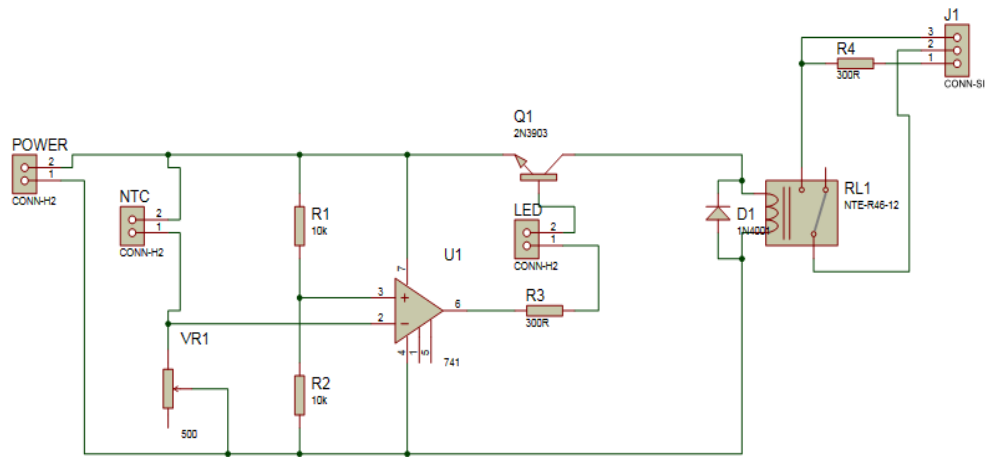

Figure 2: Sensor circuit design.

The main function of the sensor circuit is to detect the surrounding temperature in an area or zone. This circuit consists of NTC thermistor, resistors, operational amplifier, LED, transistor, and a relay control. The op-amp acts as a digital switch to turn on the LED and BJT when NTC detects temperature higher than the threshold temperature, i.e. $T_{\text{threshold}} = 60^{\circ}\text{C}$ while the relay changes its contact from Normally Open (NO) to Normally Closed (NC). The control circuit focuses on receiving signals from the sensor circuit and processes it. When the sensor senses extreme heat, the control circuit processes the signal, turns on the alarm, fire position and hose reel indicator. The control circuit will further process the fire location and determines which are the available exits in that building and display it for evacuations. As these operations involve large scale logic controls, thus a PIC microcontroller, PIC 16F877A was used to reduce the complexity of the circuit design. A LCD display was also added to the circuit to display the room where the fire breaks out. A complete circuit of the control unit is shown in Figure 3. The sensor inputs were replaced with switches for error detection during simulation.

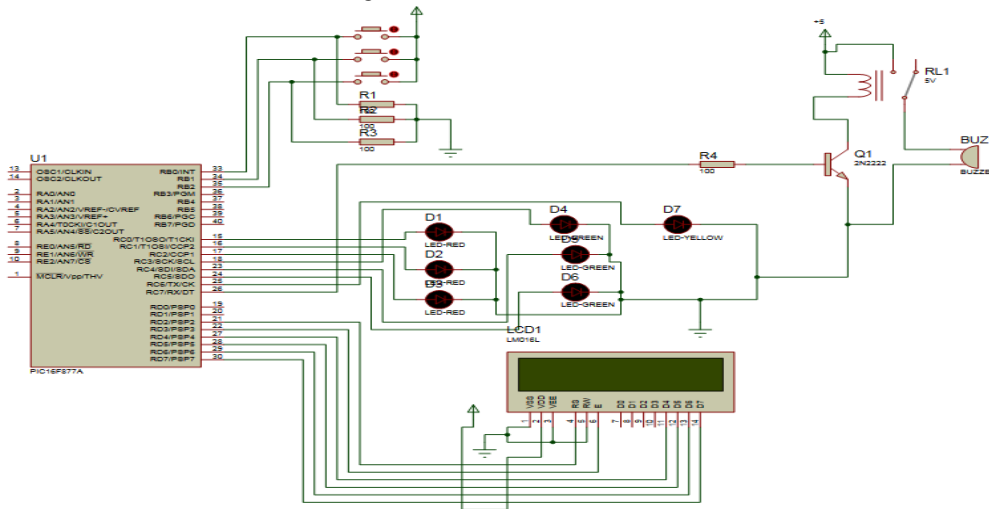

Figure 3: Control circuit.

After designing the circuits using *Proteus 7.8*, the circuits were imported in *ARES* to develop connections for a Printed Circuit Board (PCB). The hardware of this prototype was completed when PCB was printed, etched and soldered with the components as shown in Figure 4 and Figure 5. The program was burned into the microcontroller and installed on the board for full test.

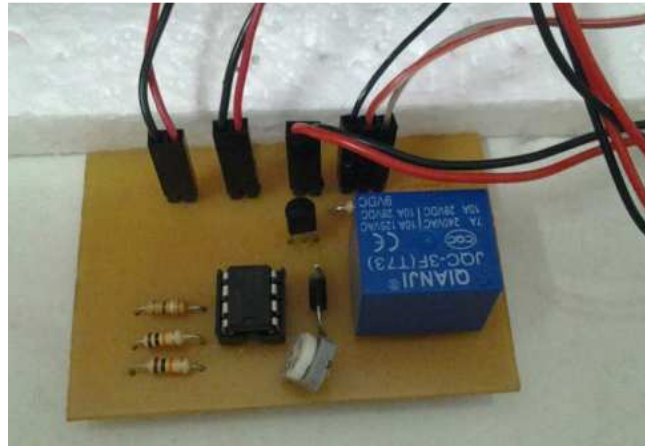

Figure 4: Sensor circuit.

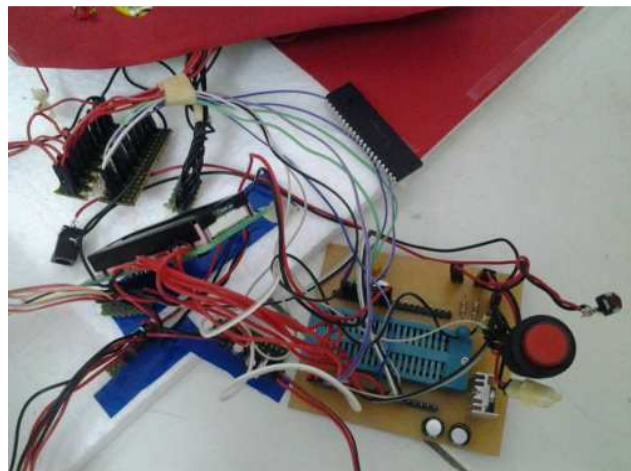

Figure 5: Control circuit with LCD display.

During the test, flowchart in Figure 1 was revised. The sensor circuit was fed with $9V_{dc}$ while the control circuit was fed with $5V_{dc}$. The temperature, corresponding resistance, sensor and control circuit output voltage were recorded for each $10^{\circ}C$ interval when the thermistor was heated with a lighter. The changes of indicators and alarm was observed and recorded. The variable resistors were tuned to compensate the tolerance of NTC.

IV. RESULTS AND ANALYSIS

The system was developed such that whenever a sensor senses temperature higher than the threshold, it will generate output to the control unit circuit for process. The control unit will determine the available escape exits and trigger the alarm and display the fire and hose reel position on the control panel. A model building as shown in Figure 6 was built to display the operation of the system.

Development of Building Heat Detection System: An Improvement Study

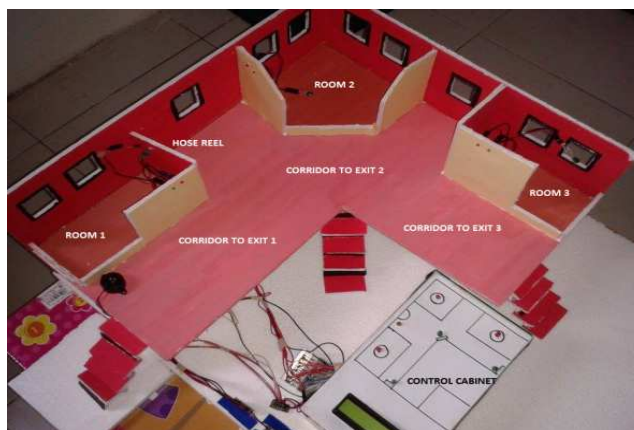

Figure 6: Floor plan for the prototype display.

In Table 1, it can be observed that when NTC thermistor is exposed to increasing temperature, its internal resistance will decrease. As the op-amp was used a digital switch, thus the output will exhibit digital characteristics of 1 and 0 where 1 represents 5V and 0 represents 0V. From Table 2, it can be seen that all the output follows the expected flow. In case of any sensor senses heat, hose reel indicator and buzzer will be turned on.

Table 1: Outputs of sensor and control circuit.

T / °C	$V_{out(sensor)} / V$	$V_{in(sensor)} / V$	R / Ω
22 (initial)	0	0	1000
30	0	0	695
40	0	0	487
50	0	0	305
60 (threshold)	4.98	4.85	207

Table 2: Truth table for the system operation.

Case	Room (sensor)			Corridor to Exit (Colour)			Room Fire Position Indicator (LED)			LCD Display
	1	2	3	1	2	3	1	2	3	
0	0	0	0	Green	Green	Green	0	0	0	OK
1	0	0	1	Green	Green	Red	0	0	1	Room 3
2	0	1	0	Green	Red	Green	0	1	0	Room 2
3	0	1	1	Green	Red	Red	0	1	1	Room 2 and Room 3
4	1	0	0	Red	Green	Green	1	0	0	Room 1
5	1	1	0	Red	Red	Green	1	1	0	Room 1 and Room 2
6	1	1	1	Red	Red	Red	1	1	1	All Rooms

*When sensor senses heat, room sensor = 1.

*When sensor senses heat, room fire position indicator = 1.

In the real time testing, it was found that the value of the variable resistor has to be tuned to a lower due the limitation of the NTC thermistor. In a normal air-conditioned room, the temperature may drop down to 20°C or lower. The thermistor will have problem in sensing the heat accurately as the temperature drops to reach thermal equilibrium before it reaches the thermistor. Besides that, it is also found out that the heat source has to be very close to the sensor to trigger the alarm. In such case, a smoke detector is proposed to be included in the system should there will be a further research on this system.

One of the advantages of this improved control cabinet heat detection system is that the system can be customized according to the structure as well as the sensor positions in a building. As microcontroller is user-friendly and easy to maintain, thus this will reduce the maintenance cost. Besides that, occupants of the building can now determine the safe escape route as it is displayed in the building. Should anyone try aid in putting out the fire, he or she can easily obtain the hose reel as it is now comes with an indicator inside the building.

It can be observed that in case 6, when all the sensors senses heat, there are no available exits. This fault was caused by the condition preset in the program. To overcome this problem, water sprinkler system is recommended to be installed together with this system by putting out part of the fire so that occupants are able to escape the building while the fire are held from spreading out of the room.

V. CONCLUSION

In this paper, an improved version of the building heat detection system prototype was designed and fabricated. This system does not only detects heat and provide early warnings to building occupants, it is also capable of showing the available exits and indicates the position of hose reel inside the building itself. Overall, this study has accomplished its objectives as well as providing a better understanding in order to improve the conventional building safety system in UTeM.

VI. ACKNOWLEDGEMENT

The authors would like to thank the Universiti Teknikal Malaysia Melaka (UTeM) for the all support given.

Development of Building Heat Detection System: An Improvement Study

REFERENCES

- [1] Fire and Rescue Department Malaysia, "Fire, Rescue and Special Service Statistic from January to June", MHLG Statistic, pp. 35, 2012.
- [2] Y.C. Yao, J. Yang, C. Huang, W. Zhu, "Fire monitoring system based on multi-sensor information fusion," in Proceedings of the 2nd International Symposium on Information Engineering and Electronic Commerce, IEEEC, pp. 1-3, 2010.
- [3] Diane K. Davies, Shriram Ilavajhala, Min Minnie Wong, and Christopher O. Justice "Fire Information for Resource Management System: Archiving and Distributing MODIS Active Fire Data", IEEE Trans. on geoscience and remote sensing, Vol. 47, No. 1, pp. 72-79, 2009.
- [4] G.K.Baddewithana, G.A.H.S.Godigamuwa, P.S.Gauder, D.C.N.Hapuarachchi, Udaya Dampage And R. Wijesiriwardana, "Smart and Automated Fire and Power Monitoring System", IEEE 8th International Conference on Industrial and Information Systems, pp. 542-547, 2013.
- [5] J. Li, X. Yao, Q. Kui, "Fire safety assessment technology research," IEEE International Conference on Control and Automation, pp.1314-1317, 2009.
- [6] Richard Jacobsson, "Building Integrated Remote Control Systems for Electronics Boards", IEEE Trans. on nuclear science, Vol. 55, No. 1, pp. 356-361, 2008.
- [7] Thomas Novak and Andreas Gerstinger, "Safety- and Security-Critical Services in Building Automation and Control Systems", IEEE Trans on industrial electronics, Vol. 57, No. 11, pp. 3614-3621, 2010.
- [8] C.N. Bagchi, "A multilevel distribute microprocessor system for a nuclear power plant fire protection system controls, monitoring, and communication," IEEE Trans on Power Engineering Review, Vol.PER-2, No.9, pp.21-22, 1982.
- [9] Yanghou Chen, "Reliability Analysis of a Fire Alarm System", Procedia Engineering, Vol. 24, pp. 731-736, 2011.
- [10] Daniel T. Gottuk, Michelle J. Peatross, Richard J. Roby, CraigL. Beyler, "Advanced Fire Detection Usingmulti-Sig Nature Alarm Algorithms", Fire Safety Journal Vol. 37, pp. 381-39, 2002.
- [11] H.H. Amer, R.M. Daoud, "Fault-Secure Multi-Detector Fire Protection System For Trains", IEEE Instrumentation and Measurement Technology Conference, IMTC, pp. 1664-1668, 2005.
- [12] Ding Hong-jun and Liu Xiao-lu, "Several Ideas on Fire Detecting Alarm for Power Supply and Distribution System", Procedia Engineering , Vol. 11, pp. 75-79, 2011.
- [13] Micro-ctl Automation Sdn. Bhd., "M900 Specifications", Mictron Product, pp. 2-18, 2006.
- [14] Siemens Switzerland Ltd., "FC206-AA catalogue", Siemens Product, pp.1-10, 2012.
- [15] Johnson Control, "Fire Control and Alarm System", Product of Safety, 2010.
- [16] R. S. Saxena, R. K. Bhan, C. R. Jalwania, and Kumkum Khurana, "Effect of Excessive Bias Heating on a Titanium Microbolometer Infrared Detector", IEEE Sensors Journal, Vol. 8, No. 11, pp. 1801-1804, 2008.
- [17] McGraw Hill, "Transducer," in Electronic Instrumentation, 3rd Ref. Book, ed. New Delhi, India, Ch. 13, Sec. 8, pp 427, 2010.
- [18] Axel Guirroy, Anthony Novell, Erling Ringgaard, Rasmus Lou-Moeller, Jean-Marc Gregoire, Andre-Pierre Abellard, Tomasz Zawada, Ayache Bouakaz, and Franck Levassort, "Dual-Frequency Transducer for Nonlinear Contrast Agent Imaging", IEEE Trans on Ultrasonics, Ferroelectrics, and Frequency Control, Vol. 60, No. 12, pp. 2634-2644, 2013.
- [19] Egon J. W. Merks, Ayache Bouakaz, Nicolaas Bom, Charles T. Lanc'ee, Antonius (Ton) F. W. van der Steen, , and Nico de Jong, "Design of a Multilayer Transducer for Acoustic Bladder Volume Assessment", IEEE Trans. On Ultrasonics, Ferroelectrics, And Frequency Control, Vol. 53, No. 10, pp. 1730-1738, 2006.