



POLITECNICO DI TORINO
Repository ISTITUZIONALE

Practical Precision Electrical Impedance Measurement for the 21st Century – EMPIR Project 17RPT04 VersICal

Original

Practical Precision Electrical Impedance Measurement for the 21st Century – EMPIR Project 17RPT04 VersICal / Power, Oliver; Ziolk, Adam; Elmholt Christensen, Andreas; Pokatilov, Andrei; Nestor, Anca; Gumez, Gulay; Kuera, Jan; Kaczmarek, Janusz; Jursza, Jolanta; Callegaro, Luca; Ribero, Luis Filipe; Koszarny, Maciej; Marzano, Martina; Ortolano, Massimo; Koziol, Mirosaw; Tran, Ngoc Thanh Mai; Rybski, Ryszard; D'Elia, Vincenzo; Rzedkiewicz, Witold. - ELETTRONICO. - (2019), p. 02001. ((Intervento presentato al convegno International Congress of Metrology 2019.

Availability:

This version is available at: 11583/2755073 since: 2019-09-25T15:58:01Z

Publisher:

EDP Sciences

Published

DOI:10.1051/metrology/201902001

Terms of use:

openAccess

This article is made available under terms and conditions as specified in the corresponding bibliographic description in the repository

Publisher copyright

(Article begins on next page)

Practical Precision Electrical Impedance Measurement for the 21st Century

– EMPIR Project 17RPT04 VersICaL

Oliver Power^{1}, Adam Ziolk², Andreas Elmholdt Christensen³, Andrei Pokatilov⁴, Anca Nestor⁵, Gulay Gumez⁶, Jan Kučera⁷, Janusz Kaczmarek⁸, Jolanta Jursza², Luca Callegaro⁹, Luis Filipe Ribero¹¹, Maciej Koszarny², Martina Marzano^{9,10}, Massimo Ortolano^{9,10}, Mirosław Koziol⁸, Ngoc Thanh Mai Tran^{9,10}, Ryszard Rybski⁸, Vincenzo D'Elia⁹, Witold Rzodkiewicz²*

¹National Standards Authority of Ireland (NSAI), 1 Swift Square, Santry, Dublin 9, Ireland

²Główny Urząd Miar (GUM), ul. Elektoralna 2, 00-139 Warszawa, Poland

³Trescal A/S, Mads Clausens Vej 12, 8600 Silkeborg, Denmark

⁴AS Metrosert (Metrosert), Teaduspargi 8, 12618 Tallinn, Estonia

⁵Institutul National de Metrologie (INM), 042 122, Bucuresti, Sos. Vitan-Bârzesti, nr. 11, Romania

⁶Türkiye Bilimsel ve Teknolojik Arastırma Kurumu (TUBITAK), Atatürk Bulvarı 221, 06100 Ankara, Turkey

⁷Czech Metrology Institute (CMI), Okružní 31, 638 00 Brno, Czech Republic

⁸University of Zielona Góra (UZG), ul. Licealna 9, 65-417 Zielona Góra, Poland

⁹Istituto Nazionale di Ricerca Metrologica (INRIM), Strada delle Cacce 91, 10135 Torino, Italy

¹⁰Politecnico di Torino (PoliTo), Corso Duca degli Abruzzi, 24, 10129 Torino, Italy

¹¹Instituto Português da Qualidade (IPQ), Rua António Gião 2, 2829-513 Caparica, Portugal

Abstract The core objective of EMPIR project 17RPT04 VersICaL is to improve the European measurement infrastructure for electrical impedance, with particular emphasis on the capabilities of developing NMIs and calibration centres. The project will seek to exploit the results of existing research on digital impedance bridges (DIBs) by designing, constructing and validating simple, affordable versions suitable to realise the impedance scale in the range 1 nF to 10 μF and 1 mH to 10 H with relative uncertainties in the range 10⁻⁵ to 10⁻⁶. The first results of the research project, including the bridge designs and details of a polyphase digitally synthesized multichannel source capable of providing voltage outputs of precise ratio and phase are presented.

1 Introduction

Electrical impedance is an important measurable quantity, not just in the field of electrotechnology but in many other fields of science and technology. From the point of view of its response to an electrical stimulus, any linear physical system can be represented by an interconnected network of impedance elements whose measurement can provide important information about the physical properties of the system. Impedance spectroscopy is a powerful measurement method used in many application fields such as electrochemistry, material science, biology and medicine, semiconductor industry and sensors [1]. To take just one example, an immunosensor for the detection of foodborne pathogens, based on the measurement of the electrical impedance of the sample, has been developed which has advantages over traditional methods in terms of portability, low cost and rapid detection [2]. Electrical impedance tomography, which forms the image of an object based on its local bulk electromagnetic properties, depends on impedance measurement and has found applications in industrial process monitoring and in medical imaging.

A vast array of impedance measuring instruments, sometimes referred to as LCR meters, is available and these instruments must be calibrated in order to ensure that the measurement results are reliable and comparable. This is especially true when the impedance measurements are performed by those without any specialist knowledge of electrical measurement methods. The traceability chain for impedance begins with the primary standards of impedance maintained at large national metrology institutes and proceeds through several intermediate steps, one of which is the calibration of artefact standards for resistance, capacitance and inductance. When it comes to the calibration of impedance meters, these standards are the workhorses upon which the calibration services depend. The joint research project entitled “A versatile electrical impedance calibration laboratory based on digital impedance bridges” (VersICaL) which is introduced in this paper is focused on this step of the calibration chain. That is, it is concerned with the development of methods and measuring systems for the calibration of impedance standards which are flexible, economic and user friendly while achieving the measurement uncertainties necessary to support high level impedance calibration services.

The research builds on the outcome of a previous joint research project “Automated impedance metrology extending the quantum toolbox for electricity” (AIM QuTE) which demonstrated, among other outcomes, that digital impedance bridges have the capacity to rival traditional bridges based on transformer ratios [3]. These novel bridges have the advantages of being economic to build, easy to operate and readily configurable to measure impedances with arbitrary phase angles. The core objective of the present project is to show that laboratories with a modest level of resources and

*Corresponding Author: oliver.power@nsai.ie

expertise can develop digital bridges and use them to realize the local impedance scale at the necessary level of accuracy without the need to depend on the external calibration of artefact standards.

A brief introduction to impedance bridges is provided in section 2. Section 3 is an outline of the VersICaL project including its main technical objectives. Section 4 gives some preliminary results of the project, including the selection of bridge designs to meet specific needs, the design of a reference model bridge that can readily be adopted by those new to the field, and a description of an improved digitally synthesized sinewave source which is used in the reference bridge.

2 Impedance bridges

The accurate measurement of electrical impedance presents many challenges, not least the difficulty in defining the measured quantity. In the 150 years since the necessity to measure impedance arose in the field of telegraphy, many ingenious measuring techniques of ever-increasing accuracy have been developed [4,5]. Almost from the beginning, bridge methods were the favoured approach to the measurement of impedance and impedance ratio. Many variations of this principle were used, and are still in use to this day, to compare like and unlike impedances. A great advance was made with the replacement of two arms of the bridge by a ratio transformer and the adoption of a fully coaxial circuit design [6]. These advances resulted in bridges capable of measuring impedance ratios with a relative accuracy of the order of 10^{-9} . Such bridges are usually employed in the calibration chains linking primary standards of impedance such as the Thomson-Lampard capacitor or the AC Quantum Hall resistance to artefact capacitance standards [7]. The spectacular performance of transformer-based bridges comes at a cost. The set-ups are difficult to build since they include many specially constructed components, they require considerable experience and expertise to operate, and are not amenable to automation. Moreover, an individual bridge configuration is required to compare any given pair of impedances with the result that the coverage of the impedance plane is severely limited. As a consequence of this the calibration services offered by NMIs rarely employ such bridges.

Recently, the advent of high resolution analogue-to-digital and digital-to-analogue converters (ADCs, DACs) has provided an alternative method for accurately generating the complex voltage ratio needed to balance an impedance bridge. These measurement set-ups are referred to as digital impedance bridges (DIBs). While DIBs cannot achieve the very low measurement uncertainties of transformer ratio bridges, they have several practical advantages. They can be built using commercially available components, they can be readily automated, and they can compare impedances with arbitrary phase angles without any significant reconfiguration. Some DIBs still rely on transformers to generate the complex voltage ratio and are referred to as digitally assisted bridges. Fully digital bridges, however, depend on high resolution DACs in the case of source bridges or ADCs in the case of sampling bridges.

3 Project Overview

VersICaL is a three year joint research project that was launched in June 2018. It is coordinated by the National Standards Authority of Ireland and, in total, nine European national metrology institutes (NMIs) from Czech Republic, Denmark, Estonia, Ireland, Italy, Poland, Portugal, Romania and Turkey and two academic institutions Politecnico di Torino and University of Zielona Gora are contributing to the work.

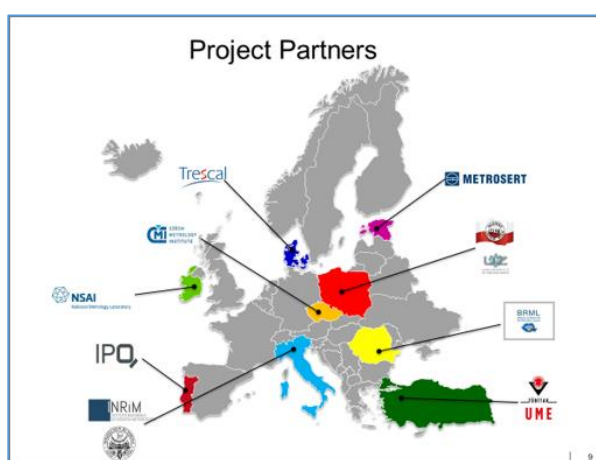

Figure 1 VersICaL Project Consortium

It is fortunate that the consortium includes some of the foremost experts on digital impedance bridges. On the other hand, some of the partners are new to the field and their experiences will show whether or not digital techniques can be readily adopted for the realization of an impedance scale in smaller NMIs and calibration centres. A stakeholder committee

comprising members from instrument manufacturers, academic research bodies, and test and calibration laboratories has been established to provide guidance and advice. This will ensure that the project focuses on real practical outcomes.

The project seeks to improve the measurement infrastructure for electrical impedance in Europe. It has three main technical objectives which are:

- (1) To review the developments in digital impedance bridges in previous research projects, including e.g. EMRP JRP SIB53 AIM QuTE, and to determine the most suitable approach(es) to be adopted in this project based on industrial and stakeholder needs.
- (2) To realise and validate inductance scales in the range 1 mH - 10 H with relative uncertainties of the order of 10^{-5} , and capacitance scales in the range 1 nF - 10 μ F with relative uncertainties of the order of 10^{-6} , (frequency: 0.12 – 1.592 kHz) suitable for primary dissemination to industry and calibration centres.
- (3) To develop a good practice guide for the application of digital impedance bridges and the realization of inductance and capacitance scales as well as a software tool for modelling uncertainties.

The work on this project is organised in five work packages (WPs), three of which are concerned with technical and scientific matters. The first WP deals with the identification of stakeholder needs and the selection of suitable DIB designs to address these needs. The construction and validation of the bridges will take place in WP2. One reference model bridge, which can serve as a model for newcomers to the field, will be built and a novel virtual training laboratory will allow remote access to it for those who wish to gain experience with using DIBs. The core element of this bridge will be a multichannel digitally synthesized sinewave source with the necessary stability (phase and amplitude) and linearity. Other bridge designs, including sampling bridges, will also be developed to meet specific needs of the partners. Since the ultimate objective of the project is to assist laboratories to efficiently establish an impedance measurement capability that meets their needs, the production of a comprehensive good practice guide, which is the principal task of WP 3, is an important one.

4 Results and achievements so far

4.1 Traceability chains and bridge designs

For most metrology and calibration laboratories, the metrological traceability of their impedance measurement results depends on the external calibration of sets of impedance standards carried out at higher echelon laboratories. This is an expensive task not just in terms of the direct calibration costs but due to the risk of damage to the standards during transit. One desirable outcome of the VersICaL project is that the participating laboratories can achieve in-house realization of impedance scales of the required accuracy so as to minimize their reliance on external calibrations. With this in mind, all the project partners were tasked with outlining internal traceability schemes based on digital impedance bridges which use, as far as possible, equipment and standards already available in the laboratory. A realistic goal of providing capacitance and inductance scales over the ranges 1 nF to 10 μ F and 1 mH to 10 H for frequencies from 100 Hz to 1592 Hz was set. The target uncertainties were in the region of 10^{-6} for capacitance and 10^{-5} for inductance.

All of the proposed traceability chains begin with a reference standard for DC resistance. In the case of the more advanced laboratories a primary realisation of the unit of resistance via the Quantum Hall effect is used. For the developing laboratories calibrated standard resistors are used. The next link in the chain are resistors with a known frequency dependence which may be specially constructed artefacts whose frequency response is calculable or so-called ac-dc standard resistors to whose DC value small, stable frequency corrections may be applied once they have been determined by a competent laboratory. Digital impedance bridges can then be used to measure the value of standard inductors and capacitors.

A number of digital bridge designs have been proposed. The centrepiece of the project will be a source bridge which is described more fully in the following section. This is intended to serve as a template to be used by less experienced laboratories who wish to develop, from scratch, an impedance measurement capability based on digital impedance bridges. A virtual training laboratory, which will permit remote operation of this bridge, is under development.

Some of the project partners, who have previous experience of digital bridges, are using different designs including some who are developing bridges based on sampling methods [9]. The multiplicity of bridge designs within the project will provide the opportunity to compare their characteristics and performance.

4.2 Design of reference model bridge

The reference model bridge is based on the simplified principle schematic of figure 2. The core of the bridge is a polyphase digitally synthesised multichannel source generating the main voltages E_1 and E_2 , the auxiliary currents I_1 and I_2 , and the auxiliary voltage E_L . The detector D , which is a lock-in amplifier, is used to measure the voltages at the detection points DL_1 , DL_2 , DH_1 , and DH_2 . The bridge is balanced when all voltages at the detection points are null, and this condition can be attained by iteratively adjusting, in magnitude and phase, either E_1 or E_2 , and all the auxiliary signals. At balance, the impedance ratio Z_1/Z_2 is directly compared with the voltage ratio E_1/E_2 , with the four-terminal pair impedance definition of Z_1 and Z_2 ensured by the auxiliary elements.

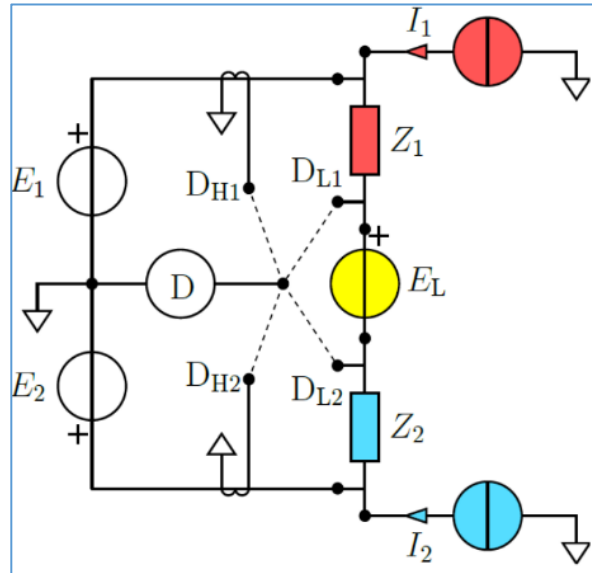

Figure 2 Schematic diagram of reference model bridge

To cancel possible gain errors of the digital source, a measurement cycle consists of two phases, whose results are averaged: in the first phase, the impedances are connected as shown in figure 2, whereas in the second phase the position of the impedances is reversed.

To automate the operation of the bridge, two computer-controlled coaxial switches, not shown in the schematic, allow to reverse the impedances between the two measurement phases and to connect the lock-in amplifier at the various detection points. The multichannel source, the lock-in amplifier and the switch are controlled by a software developed under the National Instruments programming environment LabWindows/CVI.

4.3 Digitally synthesized multichannel source

Central to the reference model bridge is a 7-channel digitally synthesized source of sinusoidal voltages which is needed to provide the signals for the main and auxiliary balances of the bridge. It is an improved version of the source developed in the AIM QuTE project [8].

The main improvement is the increased current drive capacity of the source which has been increased from 20 mA to 100 mA by the addition of a new high performance buffer at the output stage. In addition, other improvements have been made. The structure of the source system has been modified by changing the position of the low-pass filter and the power system has also been redesigned by using ultralow noise linear regulators, with ultrahigh power supply rejection ratio

The structure of the DSS consists of the three units as shown in Figure 3: the analog circuits and DAC converters, the polyphase numerically controlled oscillator (NCO) and the power supply. The analog circuits and DAC converters unit contains the 7-channel DAC stage, high performance low-pass filter stage and precise output buffers. The polyphase NCO is based on commercially available modular components which can be controlled by the bridge operating software or by an embedded controller for stand-alone operation

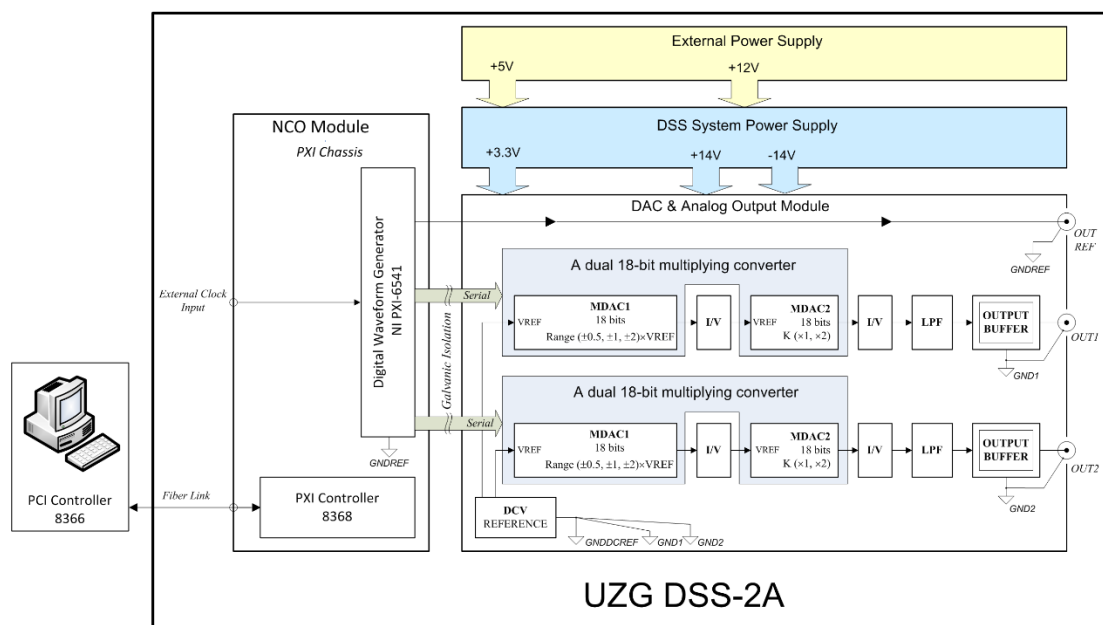

Figure 3 Schematic diagram of DSS

The accuracy of a digital bridge based on a source is directly dependent on the performance of the source. In particular, the ratio of the amplitudes of any pair of the source's outputs, as well as the phase relationship between them, must be extremely stable. Also, the amplitude of harmonics and interharmonics must be very low. These parameters of the source have been tested with satisfactory results



Figure 4 Digitally synthesized source UZG-DSS-2A

The spurious free dynamic range of the output was found to be greater than 97 dBc and 90 dBc in the unloaded and loaded (100 mA) conditions respectively. The stability of the amplitude ratio over a period of 1 hour was less than 1 part in 10^6 and the phase difference was stable to 1 μ rad. The channel crosstalk was less than -150 dB. Testing of the linearity of the output amplitude, which is another factor critical to the accuracy of a digital source impedance bridge, is underway.

5 Conclusion

The core objective of the joint research project VersICaL is to show that digital impedance bridges provide a practical and economic method of constructing and maintaining a local reference scale for electrical impedance. The main advantages of these bridges are ease of construction and operation and their ability to measure impedances with arbitrary phase angles without significant reconfiguration. With the addition of standard resistors with known frequency response an internal traceability chain can be devised which will free the laboratory from the necessity of sending sets of impedance standards to a higher echelon laboratory for calibration. The design for a reference model digital impedance bridge has been drawn up and is under construction. Its core element, a multichannel digitally synthesized sinewave source with a maximum current output of 100 mA has been constructed and tested with satisfactory results.

Acknowledgement

This project has received funding from the EMPIR programme co-financed by the Participating States and from the European Union's Horizon 2020 research and innovation programme. This paper reflects only the authors' views and EURAMET is not responsible for any use that may be made of the information it contains.

References

1. O. Kanuan (ed.) *Lecture Notes on Impedance Spectroscopy*, ISBN 978-0415-6443-03
2. T. Wen et al., *A Portable Impedance Immunosensing System for Rapid Detection of Salmonella*, *Sensors*, 17 (2017)
3. M. Ortolano et al., *An international comparison of phase angle standards between the novel impedance bridges of CMI, INRIM and METAS*, *Metrologia*, 55, pp 499-512 (2018)
4. L. Callegaro, *Electrical Impedance* (2013), ISBN 978-4398-4910-0
5. F. Overney, B. Jeanneret, *Impedance Bridges: from Wheatstone to Josephson*, *Metrologia*, 55, 5, pp. 119-134 (2018)
6. S. Awan, B. Kibble, J Schurr, *Coaxial Electrical Circuits for Interference-free Measurements*, (2011), ISBN978-1-84949-069-5S
7. J. Melcher et al., *The European ACQHE Project: Modular System for the Calibration of Capacitance Standards Based on the Quantum Hall Effect*, *IEEE Trans. Instrum. Meas.*, 52, 2, pp. 563-568 (2003)
8. [https://www.ptb.de/emrp/fileadmin/documents/aimqte/UZG Polyphase ac voltage source.pdf](https://www.ptb.de/emrp/fileadmin/documents/aimqte/UZG_Polyphase_ac_voltage_source.pdf)
9. A. Elmholt Christensen, *A versatile electrical impedance calibration laboratory based on digital impedance bridges*, 19th International Metrology Conference (2019)