



POLITECNICO DI TORINO
Repository ISTITUZIONALE

BIM and Facility Management for smart data management and visualization

Original

BIM and Facility Management for smart data management and visualization / Ugliotti, FRANCESCA MARIA. - (2017 Dec 22).

Availability:

This version is available at: 11583/2696432 since: 2018-01-09T11:54:43Z

Publisher:

Politecnico di Torino

Published

DOI:10.6092/polito/porto/2696432

Terms of use:

openAccess

This article is made available under terms and conditions as specified in the corresponding bibliographic description in the repository

Publisher copyright

(Article begins on next page)



ScuDo

Scuola di Dottorato ~ Doctoral School
WHAT YOU ARE, TAKES YOU FAR

Doctoral Dissertation
Doctoral Program in Urban and Regional Development (30th Cycle)

BIM and Facility Management for smart data management and visualization

By

Francesca Maria Ugliotti

Supervisor:

Prof. A. Osello, Supervisor

Doctoral Examination Committee:

Prof. Carlo Biagini, Università Di Firenze, Referee

Prof. Andrea Zerbi, Università Di Parma, Referee

Prof. Cecilia Bolognesi, Politecnico di Milano

Prof. Alessandro Merlo, Università Di Firenze

Prof. Chiara Vernizzi, Università Di Parma

Politecnico di Torino
2017

Declaration

I hereby declare that, the contents and organization of this dissertation constitute my own original work and does not compromise in any way the rights of third parties, including those relating to the security of personal data.

Francesca Maria Ugliotti

2017

* This dissertation is presented in partial fulfillment of the requirements for **Ph.D. degree** in the Graduate School of Politecnico di Torino (ScuDo).

Acknowledgment

I would like to say a special word of thanks to Professor Dr. Anna Osello who has always believed in my skills, giving me the opportunity to take an active part in several interesting initiatives and research projects, above all the Zero Energy Buildings in Smart Urban Districts National Cluster.

I would like to thank also the guys of DrawingtotheFuture Lab for having shared happy and enjoyable moments with me as well as working nights to get the best from our activities.

I would like to acknowledge the City of Turin for deciding first to invest in BIM methodology for the digitalization of the public heritage of the city. This collaboration has added value to my research, making this project a national reference case study published in a book.

I would also like to thank the Universiti Kuala Lumpur International Office member and my academic supervisor Professor Dr. Nadia Razali who have supported me in getting to know local BIM professionals. The industrial attachment with Telekom Malaysia has given me a great opportunity to explore the application of new technologies and procurement models in the Iskandar Regional Development, hub of innovations and pilot for smart cities in Malaysia.

Moreover, I would like to acknowledge BFORMS, Asset & Engineering Management Company, for involving me in its cutting edge and concrete projects that are a constant source of new ideas and applications.

Finally, special thanks go to my family who supported me all the way.

Abstract

BIM is for all buildings. As a disruptive technology, BIM completely changes the traditional way of working of the Construction Industry, starting from the design stage. However, the challenging issue is to establish a framework that brings together methods and tools for the buildings lifecycle, focusing on the existing buildings management. Smart city means smart data, including, therefore, intelligent use of Real Estate information. Involving Facility Management in the process is the key to ensure the availability of the proper dataset of information, supporting the idea of a BIM-based knowledge management system. According to this approach, BIM Management is achievable applying a reverse engineering process to guarantee the BIM effectiveness and to provide Facility 4.0 smart services.

Keywords: Building Information Modelling, Smart data management, Interoperability, Facility Management, Systems Integration, Cadastre of the Future, BIM Management.

Contents

1. Introduction.....	9
1.1 The problem statement	9
1.2 Motivations, objectives, research questions	11
1.3 Methodological approach	14
1.4 Structure of the Thesis	16
2. BIM and Smart City.....	17
2.1 BIM and Smart Cities Framework	17
2.2 BIM world spread and usage	22
3. BIM for Facility Management	29
3.1 Building process critical analysis and methodology	29
3.2 Case studies identification	41
4. BIM Data Organization	43
4.2 Data collection and survey	43
4.3 BIM model set up	52
5. BIM Data Usage	75
5.1 Building registry	75
5.2 Space Management.....	80
5.3 CAFM integration	87
5.4 Energy simulation.....	92

5.5 Energy modelling and monitoring.....	99
5.6 Fire Engineering and Safety Management	102
5.7 Operations and Maintenance	118
6. BIM Data Visualization	123
6.1 Reporting tools	123
6.2 3D Printing	128
6.3 Virtual and Augmented Reality.....	131
6.4 The cadastre of the future	137
6.5 Gamification approach for user awareness.....	141
7. Results.....	147
8. Conclusion	151
9. References.....	155
Appendix A: List of Publications	169
A.1. International Journals	173
A.2. Book	173
A.3. Book Chapters	174
A.4. Proceedings of International Conferences	175
A.5. Other.....	177

List of abbreviations

Acronym	Full Name
.3ds	3D Studio Max format file
.rvt	Revit file extension
.fbx	Filmbox
AECO	Architecture, Engineering, Construction, and Operations
AIA	American Institute of Architects
AR	Augmented Reality
BEP	BIM Execution Plan
BIM	Building Information Modelling/Building Information Model
BMS	Building Management System
BOMA	Building Owners and Managers Association
CAD	Computer-Aided Design
CAFM	Computer Aided Facility Management
CDE	Common Data Environment
EAM	Energy Analysis Model
EEB	Energy Efficiency Building
EIR	Employer's Information Requirements
ERP	Enterprise Resource Planning
FIEC	European Construction Industry Federation
FM	Facility Management
GDP	Gross Domestic Product
GFA	Gross Floor Area
GIS	Geographical Information System
iBIM	Integrated Building Information Modelling
ICT	Information and Communication Technology
IFC	Industry Foundation Class
IoT	Internet of Thing

IPD	Integrated Project Delivery
KPI	Key Performance Indicator
KKS	Kraftwerk Kennzeichen System
LOD	Level of Development/Level of Detail
MEP	Mechanical, Electrical and Plumbing system
NIST	National Institute of Standards and Technology
NFA	Net Floor Area
NLA	Net Lettable Area
NUA	Net Usable Area
SMEs	Small and Medium sized Enterprises
ROI	Return of Investment
TCO	Total Cost of Ownership
VR	Virtual Reality
WBS	Work Breakdown Structure

List of Figures

Figure 1: BIM for Facility Management.....	12
Figure 2: Structure of the Thesis.....	16
Figure 3: Smart City Framework.....	18
Figure 4: UK government BIM maturity levels.....	22
Figure 5: BIM adoption scenario.....	25
Figure 6: Contractors BIM adoption.....	26
Figure 7: Collaborative framework for BIM adoption in Malaysia.....	28
Figure 8: Stage of implementation of BIM in Malaysia.....	28
Figure 9: Knowledge based system.....	30
Figure 10: BIM-based knowledge management system.....	30
Figure 11: Data lack of information.....	32
Figure 12: Building process properly involving Facility Management.....	32
Figure 13: Building process correctly involving Facility Management.....	35
Figure 14: Building process involving BIM.....	36
Figure 15: Advantages and disadvantages of a FM BIM model.....	38
Figure 16: Conceptual framework of the methodology.....	39
Figure 17: Steps of the operational methodology.....	40
Figure 18: Survey workflow and outputs.....	44
Figure 19: Rooms sheet extract.....	46
Figure 20: Point cloud realized with PhotoScan.....	49
Figure 21: BIM model definition from survey and esisting documentation...50	
Figure 22: Common Data Environment description.....	53
Figure 23: BS 1192 File Naming.....	53
Figure 24: Worksharing through worksets.....	55
Figure 25: File system architecture example.....	57

Figure 26: Matching of the equivalent phases between files.	59
Figure 27: Inclusion of objects from linked files in Coordination schedules.	59
Figure 28: Level and reference grid as a separate Central model.	59
Figure 29: Pala Alpitour linked models example.....	60
Figure 30: Pala Alpitour Central models.	61
Figure 31: Comparable output of the TOBIM project.	62
Figure 32: Articulation of LODs provided by the UNI 11337.....	64
Figure 33: LODs for existing building.....	66
Figure 34: LODs for the city heritage.....	66
Figure 35: Implementation of the UNI 8290:1981 classification system.	67
Figure 36: Shared parameter definition.....	69
Figure 37: As is shared parameter groups.....	70
Figure 38: Example of space subdivision.	71
Figure 39: Building registry.....	76
Figure 40: Example of data associated with parametric objects.....	77
Figure 41: Facility 4.0 Smart services.....	78
Figure 42: Access Revit database.....	79
Figure 43: Space chargeback.	82
Figure 44: Configuration scenarios evaluation through the BIM model.	86
Figure 45: Configuration scenarios management.	86
Figure 46: Space management through the BIM model.	86
Figure 47: Revit-Archibus interoperability process for FM.....	87
Figure 48: Space catalogue and data management.	89
Figure 49: Equipment catalogue and data management.....	90
Figure 50: Space Reporting.....	90
Figure 51: Management structure for BIM models updating.....	91
Figure 52: Revit-Edilclima interoperability process for energy certification.	92
Figure 53: Example of modelling guidelines.	93

Figure 54: Visualization problems of curved walls in the EC770.	94
Figure 55: Interoperability results for the representation of vaults.....	95
Figure 56 Surface-based Revit family for shading values calculation.....	98
Figure 57: EEB project scheme.....	99
Figure 58: Proposed energy modeling optimization process.	100
Figure 59: BIM model validation process.....	101
Figure 60: Simulated and measured indoor air temperature trends.	101
Figure 61: Transversal nature of the fire implementations.	103
Figure 62: BIM Fire strategy implementation.	104
Figure 63: Fire door LODs example.	105
Figure 64: Summary of Fire implementation.....	106
Figure 65: REI wall schedule and themed graphic display.....	107
Figure 66: Fire compartments and systems installed schedule.	107
Figure 67: Escape routes objects and parameters.....	108
Figure 68: Necessary/available egress modules check.	109
Figure 69: Extinguishing means inventory.	110
Figure 70: Aspects of derogation through customized family.....	111
Figure 71: Design offices layout of the new UnipolSai headquarter.	113
Figure 72: Desk parameters for specific fire load calculation.	114
Figure 73: Fire load calculation schedule.	114
Figure 74: Fire rescue vehicles approach.....	115
Figure 75: Occupants egress simulation towards safe place.....	115
Figure 76: Data exchange with CFD specialized software.	116
Figure 77: BIM model visualization through IFC viewer.....	117
Figure 78: BIM model visualization through PDF 3D.....	117
Figure 79: Themmatization of the steel structure by zones.....	120
Figure 80: Themmatization of the steel structure by technical classification. .	121
Figure 81: parametric modelling of steel structural auctions.....	121

Figure 82: Rods in a reticular beam grouped by Assembly.	121
Figure 83: Nodes and connections implementation and management.	122
Figure 84: BIM model display through A360 viewer.	124
Figure 85: Revit-3D PDF interoperability process.	125
Figure 86: FME Exporter for Revit plug-in.	125
Figure 87: Use of Transformers to generate fire thematic view.	126
Figure 88: Example of fire project 3D PDF.	127
Figure 89: Example of fire compartment thematization.	127
Figure 90: Revit-Cura interoperability process for 3D printing.	128
Figure 91: Cura interface and print setup.	129
Figure 92: Infill density control.	129
Figure 93: Menara TM printing process.	130
Figure 94: Revit-Unity interoperability process for VR.	131
Figure 95: AR visualization process.	132
Figure 96: Revit-AR-media interoperability process for AR.	133
Figure 97: AR BIM model visualization.	133
Figure 98: Stereoscopic render visualization.	134
Figure 99: AR process for files visualization.	134
Figure 100: Overlay setting in Aurasma.	135
Figure 101: Marker enabling AR technical data visualization.	136
Figure 102: Marker enabling AR maintenance worksheet visualization.	136
Figure 103: Main idea for the cadastre of the future.	138
Figure 104: Consultation of the map through Augmented Reality.	138
Figure 105: Technologies used in the Turin BIM Interactive Map.	139
Figure 106: 3D BIM Map.	142
Figure 107: Tasks of the EEB 3D BIM Map.	142
Figure 108: Immersive vision through cardboard.	143
Figure 109: Interaction with the map through AR.	143

Figure 110: Color setting on Autodesk 3DS Max.....	144
Figure 111: Marker setting through the AR-media plug-in.	144
Figure 112: AR jig saw puzzle.....	145
Figure 113: Tetris of smart city concept toward gamification approach.	146
Figure 114: BIM management approach.....	151
Figure 115: Potential of BIM correctly involving FM.....	152

List of Tables

Table 1: Construction industry comparison.	27
Table 2: Example of room worksheets.....	47
Table 3: Floor plans and room codes example.....	48
Table 4: Availability of data before and after the TOBIM project.	51
Table 5: Summary of the breakdown strategies of a BIM model.	56
Table 6: Model connection specifications.....	58
Table 7: Example of coding a flexible duct using UNI 8210 and KKS.....	68
Table 8: Room category and type.	83
Table 9 Parameters for specific fire load calculation.....	113
Table 10: Parameters for maintenance.....	118
Table 11: BIM for maintenance summary.	119
Table 12: Summary of the interoperability tests and exchange formats.....	149

Chapter 1

Introduction

1.1 The problem statement

The great challenges of this Millennium – such as urbanization, resource efficiency, climate change, globalization – framing cities as a reference point for the future economic, social and territorial development (European Commission, 2011). In this scenario, the construction industry can provide an effective contribution towards the creation of smart cities, taking advantage of engineering methods and tools, digital workflows and technologies coming from other industrial sectors.

In the “Industry 4.0” era, the construction sector is going through a period of structural change to keep pace with the speed of innovation process. The sector represents 9% of European GDP and employs over 18 million people and 3 million enterprises, most of which are small and medium sized enterprises (SMEs) (FIEC & European Commission, FIEC Annual Report 2017, 2017). The introduction of Building Information Modelling (BIM) is a crucial aspect for the overall digitalization of the sector, improving collaboration, efficiency, and productivity in the entire construction value chain.

“Whether used to refer to a product – Building Information Model (a structured dataset describing a building), an activity – Building Information Modelling (the act of creating a Building Information Model), or a system – Building Information Management (business structures of work and

communication that increase quality and efficiency), BIM is a critical element in reducing industry waste, adding value to industry products, decreasing environmental damage, and increasing the functional performance of occupants.” (United States, 2007).

According to the *Making BIM a global success* Manifesto published by the European Construction Industry Federation, the digital transformation of the industry must be promoted both through a top-down approach, facilitated by the EU and national governments and through a bottom-up approach led by the same construction industry (FIEC, 2017). In this direction, the use of electronic tools such as building information electronic modelling has been encouraged by the European Parliament for public works contracts and design contests through the adoption of the 2014 European Union Public Procurement Directive (EUPPD) (European Parliament, 2014). In line with these European policies and with the dematerialization and digitalization actions taken by the Public Administration, the New Procurement Code was the first legislation of the Italian government including this subject (Repubblica Italiana, 2016).

However, the current approach to the Architecture, Engineering, Construction, and Operations (AECO) industry transformation is largely focused in efforts to optimize design-to-construction phase. While the benefits of BIM are now well documented in those stages, a lifecycle view is required. Most of the costs associated with a facility throughout its lifecycle accrue during operations and for the maintenance of its operative condition. Although it is estimated that the financial opportunity for digitalizing the construction processes can be in the range of 10%–20% of capital project expenditure across vertical construction and infrastructure projects (BCG, 2016), the largest prize for BIM lies in the operational stages of the project life-cycle (BIM Task Group, 2015). Thus, there is a critical need to increase the efficiency of the construction process.

The emergency of the “O” (Facility Management Magazine, 2015), Owners and Facility Management Operators, is a primary issue to be considered in the context of smart cities and BIM can help renew the international debate by promoting solutions for reducing costs and delivering efficiency. Therefore, Facility Management can become a primary driver for making decisions regarding the adoption of BIM for projects both at building and city levels.

1.2 Motivations, objectives, research questions

Against this background, this research is focused on the exploitation of BIM methodology for Facility Management (FM) field to overcome the fragmentation of the building process as well as to make effective the use of BIM models for the entire asset lifecycle. FM “is an umbrella term under which a wide range of property and user related functions are brought together for the benefits of the organization” (Spedding & Holmes, 1994). According to this definition, its aim is to achieve a powerful balance between efficiency and costs. In recent years, several studies and research projects are concerned on one side with the use of BIM for design and construction and on the other with the objectives of resource optimization, energy saving and cost reduction. The separation of these two subjects in literature until a few years ago emphasized the fact that they are traditionally considered as distinct sectors despite the relevance of the Facility Management market, which has significantly grown in the last ten years, with a general tendency of integrated services, long term contracts and expansion of strategic activities (Talamo & Bonanomi, Knowledge Management and Information Tools for Building Maintenance and Facility Management, 2015). Currently, BIM and Facility Management come into contact only after the construction phase of a building or infrastructure, resulting in loss of information during the handover phase. In this sense, BIM represents an opportunity for the AECO industry for the creation of an integrated and interdisciplinary approach oriented to the identification, quantification, and modelling of data necessary for an adequate parametric definition of all the relevant components of a facility. For these reasons, combining BIM with Facility Management represents a global interest research on the topic of information management.

The **need for knowledge** characterizing all stages of the building process represents the guiding thread that led this research activity. The digitalization of the sector initiated by BIM must envisage a full-scale review of processes aimed at organizing building knowledge in a systematic and shared way, focusing not only on the construction process but above all on the management. In fact, another important aspect to consider is that new constructions represent only 1-2% of the total buildings stock in a typical year (Kincaid, 2002). Therefore, the research needs to be addressed to developing method and tools for the built-up environment since the total lifecycle cost of a project is five to seven times higher than the initial investment cost (Lee, An, & Yu, 2012) and three times higher than construction cost (BIM Task Group, The Government Soft Landings Policy,

2012). BIM plays a key role in every building, especially considering large Real Estates, public and private, as well as complex buildings like the recent skyscrapers of modern cities. Historical buildings are also included in this scenario. The relevance of the possible results achievable in this context is decisive to obtain highest construction industry performance.

“Today’s inefficiency is a primary cause of non-value added effort, such as re-typing (often with a new set of errors) information at each phase or among participants during the lifecycle of a facility or failing to provide full and accurate information from designer to constructor.” (National Institute of Building Science & buildingSMARTalliance, 2007). A parametric model can establish a BIM-based knowledge system that can be queried in different ways according to the specific needs allowing FM managers to make better and faster maintenance decisions and provide higher-quality building performance. The BIM database can support the building modification over its life, therefore the benefits come from saving in the collection data over the design and construction process rather than waiting until the completion of the building. Moreover, it can be the starting point for simulations and interventions evaluations; reducing errors and saving in both time and resources when carrying out analysis, as all the professional parties involved into the process can get the building data from a coherent, unique repository. If the BIM FM system is kept up to date by operators, it can give an accurate record of current conditions of the facility both to the owner and the building manager. Through this mode, some of the benefits that can be achieved are (IFMA & IFMA Foundation, 2013): (i) reduced cost of utilities and services because of improved maintenance data that support better preventive maintenance planning and procedures; (ii) improved workforce efficiency thanks to the availability of reliable information and of the asset inventory; (iii) achieved integration with other FM systems.

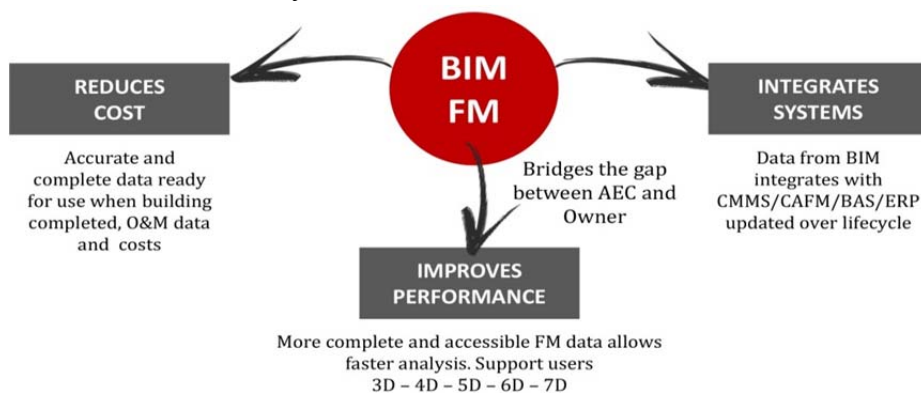

Figure 1: BIM for Facility Management.

By having in mind the idea of creating an integrated process for the heritage management, a successful use of BIM is only possible by establishing a shared protocol through all parties involved and by applying well-defined exchange standards into the process. This means that a wide range of specialized stakeholders must cooperate with each other during the different phases of the building lifecycle, within a shared working environment where the performance of every actuation will be deeply affected by the accuracy and completeness of the parametric model. The use of BIM to support design and construction practice is spreading rapidly, but the implementation for Facility Management is just at the beginning, therefore software, best practices and standards necessary for this integration are in relatively early stages of development.

In the context described above, the value of this study is to **make sense of BIM data** in order to use it effectively for data management and visualization purposes. The main goal is to organize the data in a correct way so that it can be used for lifecycle asset management. This means that the biggest challenge for BIM within FM is to set an operational methodology able to achieve the Integrated Project Delivery (IPD), from design to maintenance and management phases. The starting assumption is that the maintenance know-how is the key to optimize the entire value chain and it must affect all phases of the building process. Therefore, the core objectives of this research are the following.

- Demonstrate the advantages of adopting BIM for Real Estate Management, fully exploring the possible applications.
- Address how to create a BIM model for Facility Management.
- Maximize the interoperability between three-dimensional parametric models and tools for simulations and management.
- Give value to buildings by creating smart services from the intelligent use of the building digital database.
- Make BIM a service for the smart city through smart information management, new data visualization capabilities, and integration with other technological systems.

This research has been conducted in the strong belief that sharing knowledge and making it accessible to users is the only way to make management efficient.

In order to investigate this field of interest, this study will seek to answer the following core research questions:

- How the BIM approach can optimize data management and visualization?
- What are the benefits of BIM for Facility Management?
- What are the gaps that characterize the transition between the construction industry and the Facility Management industry?
- How to establish a collaborative process between the different actors involved in the construction and Facility Management process?
- What data is required by FM professionals in the operation and maintenance phase?
- What are the correlations between BIM and smart cities?

The research fully meets the latest European Union directives and the other provisions by international organizations in the field of digitalization and public property management, participating to the international community effort to create standard and guidelines for BIM adoption.

1.3 Methodological approach

This study addresses the use of BIM models not only as a requirement for the construction process but as methodology and value-creating collaboration tool for building management. In order to promote smart solutions within Facility Management it is necessary to carefully analyse the existing gaps in procedures, to review processes and the methods to collect and manage data as well as to generate proper business models to make the implementation successful. The availability and the updating of data constitute the most widespread issues for the built-up environment management. BIM represents a fundamental step in order to achieve an integrated digital infrastructure, thanks to its powerful modelling capabilities, visualization, analysis and data-based simulation. It can be used to digitally explore the physical and functional characteristics of a project, therefore allows us to understand, evaluate, simulate and solve optimally complex problems associated with various types of new and existing buildings. Starting from a critical analysis of the current use of BIM in the building process and its spread in the world, the research aims to highlight the procedural and operational potential associated with the systematic use of digital innovations in the perspective of

Facility Management. The study tries to answer the identified research questions by activating several projects and case studies in order to embrace different aspects of the process. Furthermore, buildings and structures differ in types of use (e.g. residential, commercial, municipal, infrastructural), in age (e.g. new, existing, historical heritage) and in ownership (e.g. private owner, housing association, authorities, universities). These differing conditions are influencing the application of BIM, its level of information and its supporting functionalities regarding design, construction, and maintenance processes due to stakeholders requirements (Volk, Stengel, & Schultmann, 2014). According to this framework, the study states the need to clarify the meaning and the implications of using BIM within Facility Management field, by promoting a differentiation of BIM model applications depending on the situation. The objective is to correctly set FM BIM models able to collect and manage all the relevant information of facilities (e.g. technical documents, aspects related to energy efficiency, maintenance, space planning), starting from the survey in the case of existing buildings, which can be integrated with building lifecycle management systems. In relation to this, the research is structured around three topics considered essential to ensure an effective data management: *Data Organization*, *Data Usage*, *Data Visualization*. In fact, only a good data organization at the beginning of the process allows the BIM model to be used in contexts and for very different purposes with each other. Direct use of BIM data, as well as systems integration across CAFM and CMMS platforms or simulations software, are tested to ensure connection with facility activities. On the other side, reporting tools, 3D printing and Virtual and Augmented Reality applications are explored to test new ways to communicate both technical and dissemination data. In fact, displaying information in a simple and direct way represent the enabling factor to promote knowledge at all levels, from designers, to managers and citizens as well as from buildings to districts and city. According to this approach, the present research points to extend the meaning of Building Information Model and Modelling, by introducing the more inclusive notion of *BIM Management*, understood not only as an integrated process leading to management, but *as a process* that suffers from management experience to set a practice for the building lifecycle. The most relevant elements of this study, coming from several practical experiences, aim to become conceptual and operative guidelines for BIM Facility Management Models. Real case studies approached during this research, also documented through papers published in journals and presented at national and international conferences, will help to spread the correct methodological approach in this field for both brownfields and new buildings for the improvement of the Italian sector.

1.4 Structure of the Thesis

This study is designed to be read in sequence to gain an understanding of the general concepts before working towards a more detailed description of actions and recommendations, as described below.

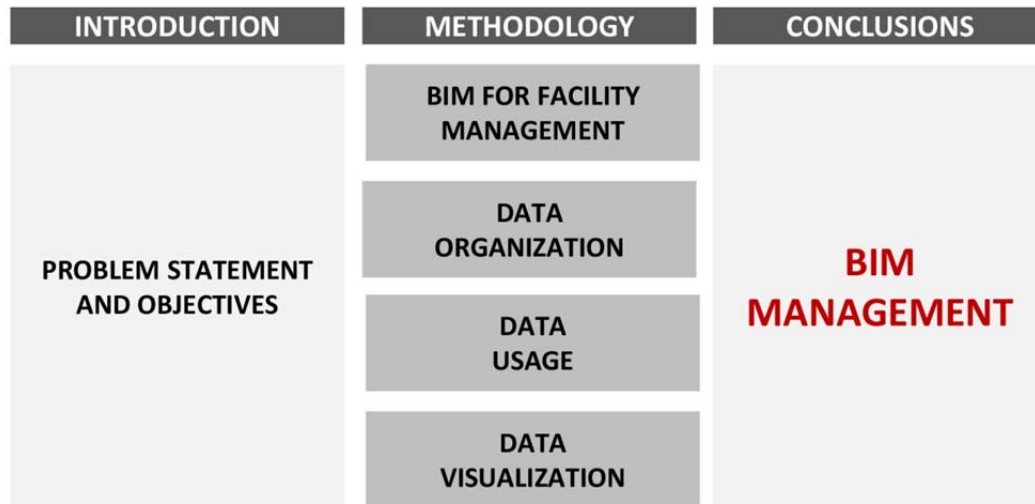

Figure 2: Structure of the Thesis.

Chapter 1 introduces the problem statement and summarizes the key topics covered in the study and the main objectives.

Chapter 2 presents the general framework of the research and the spread of BIM at international level.

Chapter 3 introduces the specific problems addressed in the research following a critical interpretation of the current use of BIM within the building process. The methodology is developed starting from the analysis of the existing research gaps and the definition of Facility Management BIM models.

Chapters 4, 5, 6, constitute the application part of the thesis and consist of an in-depth overview of the core aspects of the methodology that include the organization, usage, and visualization of BIM data, supported by case studies.

Chapter 7 offers a summary and discussion of the research findings, implications for practice, and recommendations for future research.

Chapter 2

BIM and Smart City

2.1 BIM and Smart Cities Framework

Cities play a key role for the future development of the planet. Today more than half of the world's population live in cities and this value rises to over two-thirds in EU28. At the same time, the continuing urbanization and overall growth of the world's population is projected to add 2.5 billion people to the urban population by 2050 (European Parliament, Mapping Smart City in the EU, 2014). Furthermore, the number of **mega-cities** is increasing, particularly in Africa and Asia, and by 2030 it is estimated that there will be 41 urban agglomerations with at least 10 million inhabitants each (United Nations D., 2014). It is a global challenge, where the use of technologies and advanced processes is crucial to provide innovative solutions as well as generating economic prosperity and social wellbeing to meet the long term objectives of Smart Cities.

A **Smart City** provides “the effective integration of physical, digital and human systems in the built-up environment to deliver a sustainable, prosperous and inclusive future for its citizens” (The British Standards Institution, 2014). In that framework, it is not a single system defines an intelligent city, but an interconnected network of innovations, “**a system of systems**” (Mitchell, 2011), focusing on the interaction between network and network and between city and final users with the goal of making sure that the city can be more suitable to the citizen's needs, and the citizen is increasingly active in the creation of new sustainable cities. **Resilience** provides a fresh perspective on sustainable development exploring “the reactive, recovery and adaptive capacities and also the transformability of urban systems” (Chelleri & Olazabal, 2012).

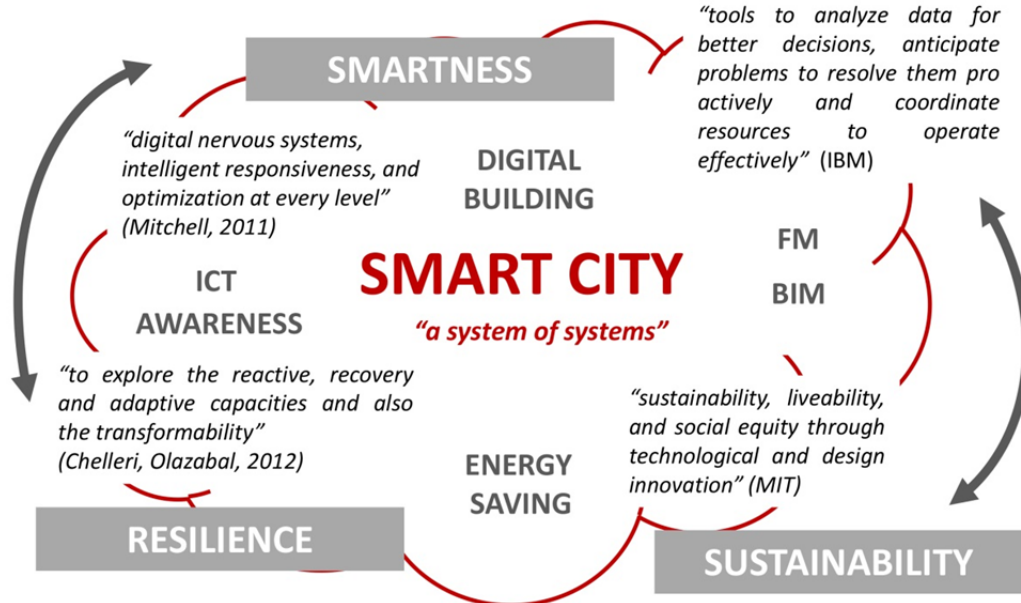

Figure 3: Smart City Framework.

Although often associated with energy efficiency and sustainability, smart cities are more than that; concerning the efficiency of urban operation and services and how these services can be better integrated with real time information and analysis. Information and Communication Technology (ICT) allows us to correlate data, processes, systems and methods often very different from each other with the aim of making them available. At the same time it links and strengthens networks of people, businesses, infrastructures, resources, energy and spaces, besides providing intelligent organizational and governance tools (European Parliament, Mapping Smart City in the EU, 2014). Cities managers need to have tools to analyse data for better decisions, anticipate problems to resolve them pro-actively and coordinate resources to operate effectively (IBM Corporation). In this sense, a better definition of smart cities comes from the Chinese National Smart City Standardisation, which talks about "a new concept and a new model, which applies to the new generation of information technologies such as the internet of things, cloud computing, big data and space/geographical information integration, to facilitate the planning, construction, management and smart services of cities" (ISO/IEC JTC 1, 2014). Therefore, a smart city is structured around an **intelligent data usage** that has to be shared to enable a city to work better. As many aspects of smart environments are already in use through internet-controlled building management systems (e.g. lighting and temperature regulation within buildings, traffic management systems, real-time information about means of transport), managing the physical assets and buildings represent a fundamental field of application of smart technology to enable better decisions about future maintenance and use of those assets. Moreover, according to the European Union Directive on the Energy Performance

of Buildings (European Parliament & Council of European Union, Directive 2002/91/EC of the European Parliament and of the Council of 16 December 2002 on the energy performance of buildings, 2002), buildings use 40% of the total EU energy consumption, for the operations of heating, cooling and lighting in buildings, and generate 36% of greenhouse gases (GHG) in Europe.

The **construction industry** can make a significant contribution to smart city development, both creating new and smarter buildings and infrastructure and upgrading and retrofitting existing buildings, which are the large part of the Real Estate. In addition, the challenge of digitalization, in which the building sector is facing in a late way compared to other fields, promotes new tools and methods to realize the Integrated Project Delivery (IPD) aiming at achieving cost savings and streamlining the construction process. The multi-scale approach, from the building scale to the city, includes: (i) knowledge sharing among players (e.g. contractors, architects, engineers) and stakeholders, (ii) performance monitoring and management, wherein ICT plays a dominant role, (iii) use of collaborative building management tools that integrate the whole lifecycle information from sourcing to building construction, facility management and refurbishing and end-of-life, (iv) a behavioural change of end-users and consumers regarding energy saving as well as data management (European Commission, Energy-Efficient Buildings Multi-annual roadmap for the contractual PPP under Horizon 2020, 2013). Hence, only an integrated approach that includes technology, collaborative tools, digital buildings, facility management and user awareness can have a strong impact on the cities of tomorrow.

Building Information Modelling (BIM) methodology is the way to overcome the inadequate information sharing within the construction industry, both for decision making and operational tasks. Currently, BIM represents the most appropriate management system to support the Building Lifecycle Management (BLM). BIM under different names such as product model, virtual building and intelligent object model has been in use only for the last twenty years, but its history started earlier. In the late 1960s Eastman described BIM as “the ability to represent a fixed set of polyhedral forms - shapes defined by a volume enclosing a set of surfaces - for viewing purposes” and some years later as a “digital representation of the building process to facilitate exchange and interoperability of information in digital format” (Eastman, Teicholz, Sacks, & Liston, 2011). As defined in the original National Building Information Modelling Standards document “BIM is a digital representation of physical and functional characteristics of a facility”, a “shared knowledge resource for information about a facility forming a reliable basis for decisions during its lifecycle from inception onward” (National Institute of Building Sciences & buildingSMARTalliance, National BIM Standard-United States ®, 2015). Parametric tools enable new user groups to interact with, navigate and modify the virtual designs, and to test and experience several options at unprecedented low cost (Ratti, 2014). In addition, BIM enable cross-disciplinary co-location of design information and integration of a range of

platforms (Ratti, 2014). “For a contractor, BIM is the virtual construction of a facility or structure that contains intelligent objects in a single source file that, when shared among project team members, intends to increase the amount of communication and collaboration” (Hardin, 2009). In fact, the acronym BIM can be intended as two different aspects that can be appropriately distinguished by spreading out the following equation: “BIM = BIM + Interoperability” (Osello, Building information modelling. Geographic information system. Augmented reality per il facility management, 2015). As an activity, BIM is composed by the set of processes applied to create, manage, derive and communicate information among stakeholders at various levels, using models created by all players, at different times and for different purposes, to ensure quality and efficiency throughout the entire building lifecycle. Building Information Modelling is a working method based on cooperation between different professionals involved in the construction process from a relational database shared. Instead, the building information model is a digital three-dimensional representation of a building, based on objects, corresponding to real world components (e.g. doors, walls and windows), with associated relationships (with other objects), attributes (e.g. materials) and properties (e.g. cost, construction phases, maintenance information). The possibility to have a unique and coherent three dimensional building model, where all the information coming from the design and construction phases is collected, paves the way for more advanced experimentations for integrating operations and maintenance information and enabling the interoperability within Facility Management systems (Talamo & Bonanomi, Knowledge Management and Information Tools for Building Maintenance and Facility Management, 2015). “BIM can link data from manufacturers, construction data and communications into one fully integrated and robust facility dashboard. Facility managers can use BIM to gather usage data, prepare maintenance schedules using predictive data, manage daily operations and plan for future purchases and construction additions. Full equipment data including operating parameters, predictive data, service history, replacement price and links to other manufacturer data, combined with a fully rendered 3D depiction of the equipment creates a powerful tool for facility managers” (InfoComm International, 2011). In this sense, the information modelling evolves dimensionally - from 3D to 4D for scheduling, 5D for estimating, 6D for sustainability, 7D for Facility Management - becoming a “tool for an effective and sustainable facility management process” (Karlshøj, 2014). “Clearly, all of the data is not entered into one model or one system. This therefore requires the interoperability of systems so that data can be communicated from upstream systems for downstream use” (International Facility Management Association, 2013). The interoperability, achieved by mapping internal data structure of applications in universal data model (National Institute of Building Science & buildingSMARTalliance, 2007), identifies the need to pass data between applications (Eastman, Teicholz, Sacks, & Liston, 2011).

As can be seen from the above definitions, BIM is both a powerful methodology and system for **smart data management of buildings**. Hence the reference context of this thesis, affirms the strong connections of BIM with the concepts of smart city applied at building level. To summarize, the points of strength are the following.

- Buildings have a large impact on cities, both in terms of economic, efficiency and quality of life. Therefore, BIM can contribute one side to better manage the existing heritage focusing on costs and energy saving, and, on the other to, control the development of mega-city and new urban development and the potential use of the assets.
- BIM is a powerful tool for planning, enabling a better quality of projects due to the reduction of errors, disputes, risks, cost and time whether for new construction or renovation. The speed of BIM visualizations and computations allows us to perform accurate simulation scenarios and achieve the best design solutions.
- BIM supports all levels of the communication process, exploiting new ways for data visualization and the presentation of projects. Thanks to the three-dimensionality of space and the interaction with new technologies, designers, public administrations as well as citizens can better understand design solutions and implement knowledge about the heritage.
- Collaboration and data sharing enabled by the BIM methodology are the key words for the entire construction value chain, also improving the relation between the building industry and the other sectors. Moreover, BIM data optimization during the building lifecycle promotes smarter facilities management services.
- BIM provides a wider perspective to analyse the city heritage, promoting analytics tools for asset management, i.e. implementing Geographic Information System (GIS) with building data. This makes effective management of facilities at the city/district levels (e.g. refurbishment but also systems networks evaluation for energy-intensive buildings).
- BIM data can be combined to other data set through ICT, providing a cross-scale dynamics vision. Building manager can access real-time information about the service installed, making accurate assessments of the asset operating condition, enabling its better usage and utilisation.

2.2 BIM world spread and usage

Nowadays BIM has taken a global perspective as it enables the challenge to digitize the construction sector, optimizing the level of the entire industry chain. Although BIM is not new, it requires profound cultural changes that make the use at different stages between countries. The adoption process of BIM necessarily goes through successive implementation steps, which gradually support the transition of the building industry from CAD drawings into the digital age. In this scenario, the concept of *BIM maturity levels*, conceived and promoted at European level by the British Government (British Standards Institution, PAS 1192-2:2013 Specification for information management for the capital/delivery phase of construction projects using building information modelling., 2013), has become the accepted definition of what criteria is required to be considered BIM-compliant. The summary below illustrates the articulation of the levels, highlighting some reflections on the subject (NBS, 2014; Rizzarda & Gallo, La sfida del BIM. Un percorso di adozione per progettisti e imprese, 2017; areo blog, 2017), also considering the implications for handover.

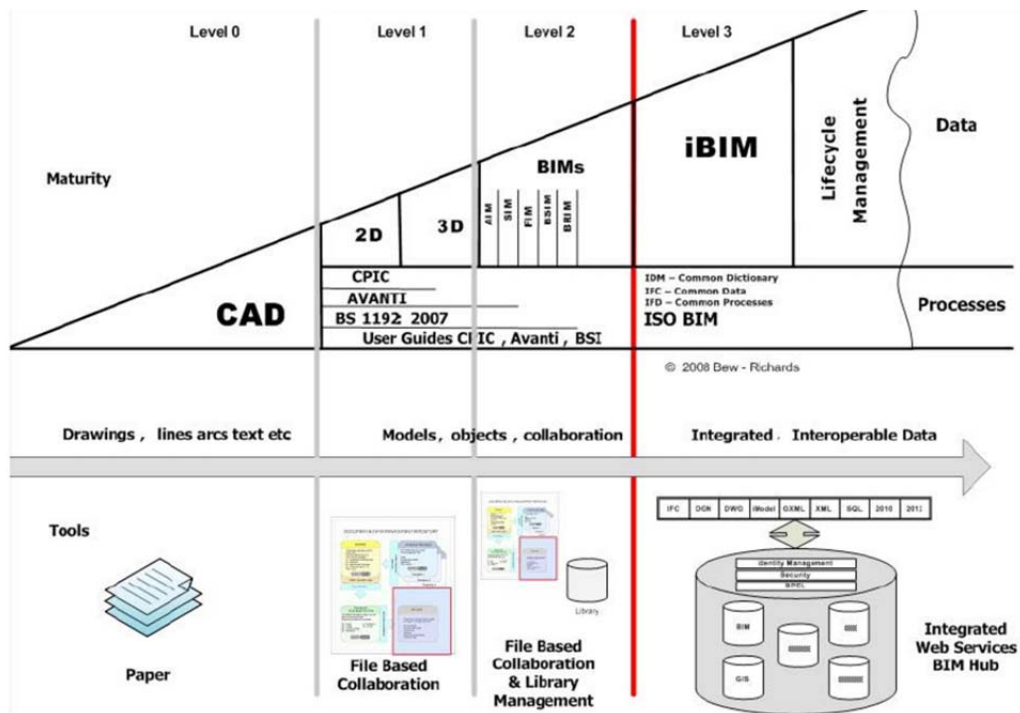

Figure 4: UK government BIM maturity levels.

Source: <http://blog.areo.io/bim-levels-and-asset-information-management/>

- Level 0: It is the 2D CAD level, where standards system for the work organization, such as ISO 128-20, is required. Outputs are shared by traditional paper drawings or electronic prints (e.g. PDF) constituting separate information sources. At this stage there is no form of collaboration. For this reason, it is common that there is no perfect match between the drawings and data. Facility management has only geometry as a starting point and it manages data through spreadsheets and simple databases as a result of a data acquisition process.
- Level 1: It is the first step in using BIM within an organization, without collaboration with other industry professionals. It is a mix of 2D and 3D information and models are not shared among project team members. The work adopts internal or international standards such as the BS 1192:2007, especially for the nomenclature of the elements, and collaboration is introduced for electronic sharing of data by means of a Common Data Environment (CDE), often managed by the contractor. Many organizations are currently operating at this level, each publishes and maintains its own data although there is no collaboration between different disciplines. As there is no link among disciplines models and Operation & Maintenance documentation, manual work is needed to establish those connections. However, architectural models/drawings can be linked to CAFM systems to manage floorplans and allow space management.
- Level 2: It is the collaborative BIM level as all players create and use their own 3D models not necessarily working on a single shared model. The crucial aspect is the exchange of information between different parties which must occur through a common file format (i.e. IFC or COBie) to make a federated BIM model that is used for coordination and project communication. BIM objects with data and documentation can be linked to CAFM systems by the integration of BIM viewer functionality. Spaces and equipment can be part of the CAFM domain but additional properties are accessible only in the BIM model.
- Level 3: This represents full collaboration between all disciplines and professionals by means of using a single shared project model held in a centralized repository. All the team members can work at the same time in the same model, receiving real-time updates, thus realizing the principles of concurrent engineering. Lifecycle management of data is part of the requirements to be addressed and FM systems are able to import BIM data from discipline as-built models, maintaining the links between geometry data and documents. However, there are still several barriers to the adoption of this level, both at the technological level and at the legal level, including copyright and liability.

The **US** is the leading country in adopting BIM followed by UK although neither of these countries AEC industries have fully adopted BIM. From the beginning of its spread, it was clear that standards and guidelines are necessary to work efficiently in a shared way. Therefore, organizations such as Building SMART Alliance, National Institute of Building Science (NIBS) and BIM Task Group, started working for the management and exchange of information from one system to another by intervening at the base of its production process. However, different types of standards are necessary since each region has their own regulations and traditions within the construction industry so they need to be adapted to different cultures. Moreover, the public sector plays a significant role in spreading and implementing this technology and methodology approach to construction and management of buildings, starting from public procurements. So a strong collaboration between governmental and public bodies, industry and educational institutions is necessary to guarantee the success of BIM.

Europe is now host to the greatest regional concentration of government-led BIM programmes in the world (NBS, National BIM Report 2016, 2016). Finland, Norway and UK were first to set standards starting BIM projects since 2000, followed by procurement policies from Sweden, Denmark, Netherlands. In 2009 the Portugal has obliged the *eProcurement* since November 2009, while in 2004 the UK government has been set BIM level 2 as a minimum target for all work on public-sector work by 2016. Most recently joint government and industry initiatives are from France, Germany and Spain. According to a European Commission study, public authorities that have already implemented e-procurement solutions have achieved savings of between 5% and 20% for the procurement cost (European Commission, Communication from the Commission to the European Parliament, the Council, the European Economic and Social Committee and the Committee of the Regions: A strategy for e-procurement (COM(2012) 179 final), 2012). The European Commission, endorsed BIM as an enabler for delivering public works by encouraging its use in the EU Public Procurement Directive (European Parliament, Directive 2014/24/EU of the European Parliament and of the Council of 26 February 2014 on public procurement and repealing Directive 2004/18/EC, 2014). Following this Directive, many states are considering introducing BIM into the legislative system. The newly-formed EU BIM Task Group, co-funded by the European Commission, aims to bring together these national initiatives into a common and aligned approach to develop a world-class digital construction sector.

Italy is also moving in this direction by approving on 18 April 2017 the New Procurement Code (Repubblica Italiana, Decreto Legislativo 18 aprile 2016, n.50 Codice dei Contratti Pubblici, 2016). At the local regulatory level, the UNI 11337:2017 has recently been adopted, which introduces collaborative processes and the use of a shared data exchange environment in addition to the concept of LOD. According to the BIM Report 2015 (Anafyo, 2015) only in 2015 BIM has generated a turnover of € 1 billion between public procurement and large

commissions in Italy. 80% of projects are in the north, 60% concerns public utilities (e.g. hospital construction, infrastructure, public buildings), and 66% are new constructions. Despite this scenario, Bellicini in the latest CRESME report on building industry (CRESME, 2016) states a very low rate of BIM adoption and application. The affected market segments will be the property management sector by non-small size owners and construction companies using BIM as a strategic tool (Samori, 2017). However, the cost of the error is currently a profitability model, representing an obstacle to the spread of the methodology.

In **Asia**, Singapore, Hong Kong and Korea are the most active states in terms of BIM. In Singapore, the BIM adoption rate is as high as 65% and the site productivity increased to 2 percent per annum for the last two years (Phang, 2017). There, the Construction and Real Estate Network (CoreNet), is the main organization involving in the implementation of BIM methodology in governmental projects. Most of the mega-structures such as Gardens by the Bay (Singapore), Dongdaemum Design Plaza (South Korea), Bird's Nest (China), Ngurah Rai International Airport (Indonesia) have constructed using BIM solutions. Japan as well as the Middle East, Dubai and others have invested in BIM-related rail projects and large infrastructure, representing approximately 60 percent of global infrastructure spending by 2025 (Phang, 2017).

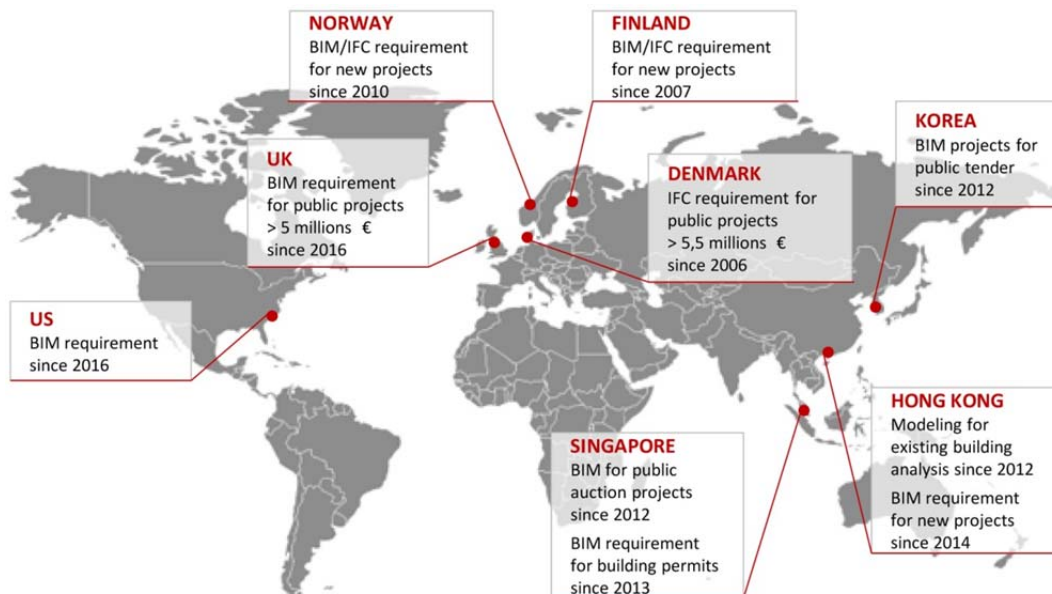

Figure 5: BIM adoption scenario.

According to the McGraw Hill Construction report (McGraw Hill Construction, The business value of BIM for construction in major global markets: how contractors around the world are driving innovation with Building Information Modeling, 2014), 12% of the contractors in France, Germany and UK use BIM since six or more years, while in North America has grown dramatically in recent years, now topping 70%. Japan, South Korea, Australia/New Zealand represent

the next tier of maturity, with the majority of their contractor BIM users falling in the three to five years of experience. This finding reflects the more recent adoption in these regions, but it also shows how rapidly BIM is advancing, with a 65% BIM adoption rate for South Korean contractors as an example.

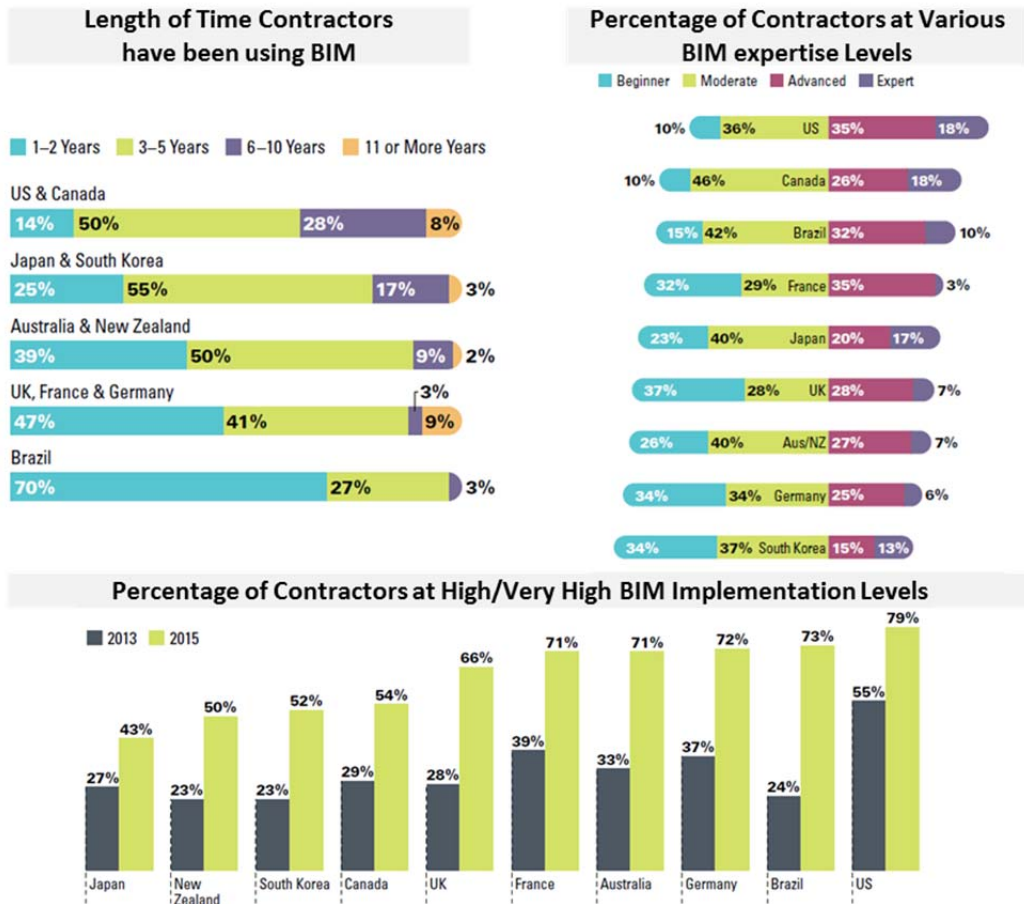

Figure 6: Contractors BIM adoption.
Source: McGraw Hill Construction Report 2014.

As global markets continue to adopt BIM, an increased focus on setting standards for BIM implementation will accelerate world-wide adoption. According to the *World Building Information Modeling (BIM) Market – Opportunities and Forecasts, 2015-2022* report (Allied Analytics LLP, 2016), the world market for BIM will reach \$ 11.7 billion by 2022, recording a 21.6% annual growth rate in the period 2016-2022. However, there are still many barriers that hinder the adoption process, including software and training cost, organizations and owners not familiar with BIM, companies lack technical BIM expertise.

Europe countries vs developing countries

BIM Technology has proven effective and useful across the sectors in the built-up environment. This is critical to promote this emerging technology, particularly in developing countries (Rogers, Chong, Preece, Lim, & Jayasena, 2015). The Erasmus Mundus Exchange Program gave me the opportunity to carry out a comparative study on the use of BIM in Europe and in Malaysia, analysing the strengths and the barriers still existing. As energy issues within the target of Roadmap 2050 (European Climate Foundation), aiming at moving towards a competitive low-carbon economy, and refurbishment are crucial elements for the existing building stock in Europe, the construction industry has been identified as an important area in contributing to the economic growth in Malaysia (Ali Khan, Liew, & Ghazali, 2014). Different resources price and availability, climatic conditions and building typology constitute some of the driver factors of these two environment.

Table 1: Construction industry comparison.

EUROPE	MALAYSIA
BUILDING STOCK	
<ul style="list-style-type: none"> • Market in crisis • Area development • Built-up environment • Historical building 	<ul style="list-style-type: none"> • Growing market • Regional development • New construction • Skyscrapers
RESOURCES	
<ul style="list-style-type: none"> • Limited resources • Heating systems • Responsible use • EU Energy Directive and objectives 	<ul style="list-style-type: none"> • Resources availability • Cooling systems • Not responsible use • Not Energy Directive
BIM	
<ul style="list-style-type: none"> • Public stakeholders • Publicly funded construction projects 	<ul style="list-style-type: none"> • Private stakeholders • Awareness raising program promoted by the government

The Malaysian construction industry contributes significantly to the economy. Several professional bodies and institutions are governing the practice in the industry. Numerous policies have been prescribed that are intended to address chronic, systemic weaknesses within the construction sector (Rogers, Chong, Preece, Lim, & Jayasena, 2015). In Malaysia, BIM's adoption is progressing well driven primarily by the private sectors that realized the significant benefits to be derived from an intelligent adoption of BIM. Beginning in 2011, the Construction Industry Development Board (CIDB) has been complimenting the efforts of BIM initiatives by providing sustainable environments where BIM can survive and thrive. The efforts included an estimated RM1.5 million (USD340,000) investment (Phang, 2017) in BIM awareness programs with the industry and the setting up of the National BIM Steering Committee. The committee consists of the government agencies, professional bodies, academician and relevant industry

players with the intention to chart the way forward for a wider and wiser implementation of BIM.

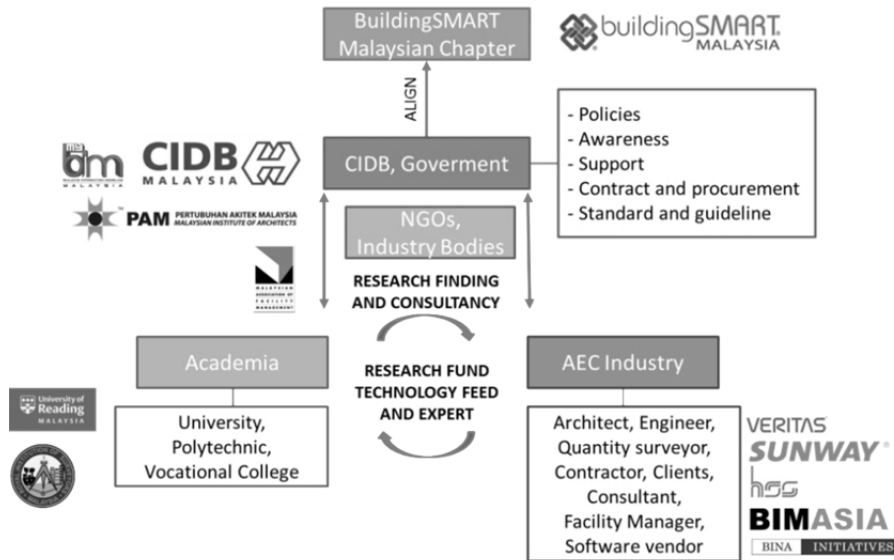

Figure 7: Collaborative framework for BIM adoption in Malaysia

Despite the stage of implementation of BIM in Malaysia being set back from Europe, the impacts on operations optimization are significant combining BIM with Facility Management, both for new development and existing buildings that are more recent and characterized by high vertical development. Unlike in Europe, BIM can help to design entire parts of the new mega-city. In this sense, BIM can provide an integrated multidisciplinary approach to challenge conventional thinking models and to expand the network on the topic of the Greater Kuala Lumpur. Furthermore, Iskandar Malaysia Regional Development represent an ideal place to experiment with new technologies and new procurement models as an hub of innovations and a pilot for Smart Cities project in Malaysia.

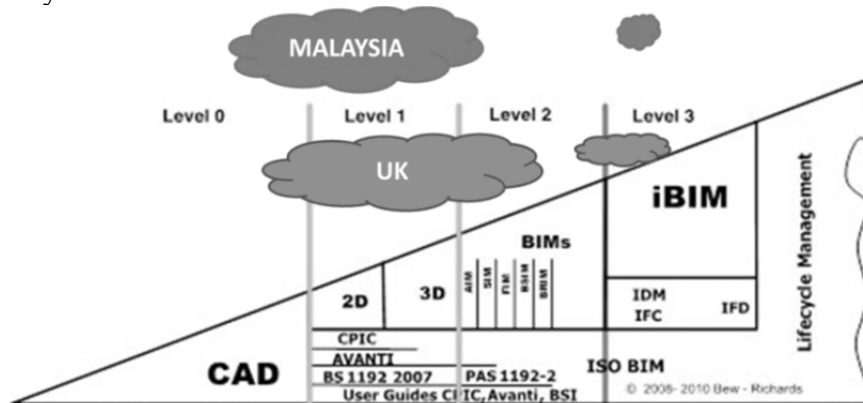

Figure 8: Stage of implementation of BIM in Malaysia.

Chapter 3

BIM for Facility Management

3.1 Building process critical analysis and methodology

The construction industry is a complex and dynamic industrial sector that involves different players at different stages. The construction organisation encompasses functions such as planning and design, construction as well as operations and industrial production. While stakeholders include client, designer, contractor, and manufacturer that are involved from the beginning of the project to its completion, operators and end users. All these phases and expertise have in common a truly critical aspect represented by *knowledge*. If I am a designer, I have to know the best solution for the project according to the context and the specific needs. If I am the project controller, I need to know when and where every single component will be installed. If I want to sell the building, I need to know the main characteristics of the property. If I want to implement energy efficiency I need to know the stratigraphy of the envelope and the installed systems to perform energy simulations. Therefore a knowledge-based system is an essential condition to be able to predict future behaviours and cost, develop indexes for the systematic comparison of process and performance, and have more awareness about criticalities (Talamo & Bonanomi, Knowledge Management and Information Tools for Building Maintenance and Facility Management, 2015).

Accordingly to the need of knowledge, I started working on the idea of a BIM-based knowledge management system, putting the BIM model at the centre of the process. Building Information Modelling represents the most appropriate approach to storing data and making it accessible during the building lifecycle, promoting a smart digitalization process.

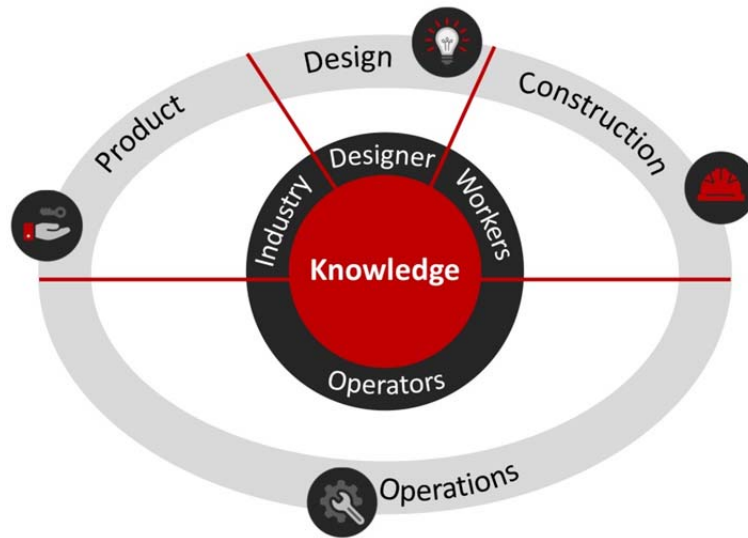

Figure 9: Knowledge based system.

BIM has been conceived to manage complex problems as it intersects both the productive and technological world. Its potential is given by the dual instrumental and processual nature that cannot operate independently, supported by norms that define standard and regulations. It is fundamental to point out that BIM is a work methodology based on the sharing of information throughout the building life cycle, not merely a set of tools for designers. Certainly in the case of new buildings, it is recommended to adopt the BIM workflow since the design phase to gain great benefits during the construction.

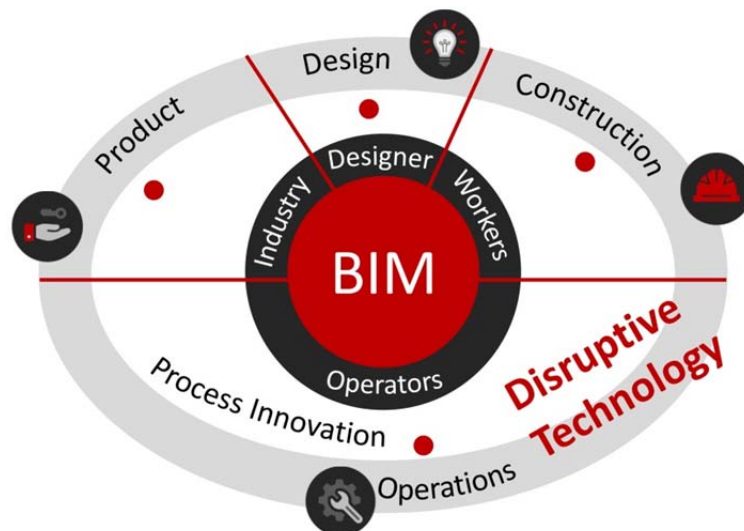

Figure 10: BIM-based knowledge management system.

Prototype modelling also makes it possible to realize components from digital objects to verify the reproducibility of products in the industrial field. It may be useful to set up a model also during the execution phase in the case of complex projects initially not conceived in BIM, to implement an advanced management system integrated with the BIM database. However, the real revolution is to use BIM for the management phase, where existing buildings play an essential role in the national and international scenario.

The first outcome of my research is that the BIM process can start at any time creating an overall process innovation for the building sector.

BIM marks an epochal transition, which cannot simply be compared to the passage from hand-drawn design to CAD of the eighties as it involves a radical change in the way of working. BIM modelling conceives the virtual model as a very close representation of the building realization, thinking in terms of components and three dimensional connections. The approach is collaborative and process-oriented overcoming the conventional practices. Moreover, the close relationship with technology provides a strong context to BIM processes, opening new opportunities to connect buildings with sensors, real-time data, and Cloud computing. In this sense, BIM can be recognized among the *Disruptive Technologies*.

Fragmentation is the most significant problem that characterizes the building process, involving two levels: fragmentation of the construction industry and of the project (Alashwal & Hamzah, 2014; Mohd Nawi, Nazim, & Bahauddin, 2014), which have both relevant influence on project performance and efficiency. The lack of data interoperability between architects, engineers, contractors and owners was quantified, for the first time in this sector, in terms of costs impacts over the building lifecycle in December 2004 by the National Institute of Standards and Technology (NIST). According to the Cost Analysis of Inadequate Interoperability in the U.S Capital Facilities Industry (NIST GCR 04-867) report, it cost \$15.8 billion, of which, two-thirds of this are attributed to Operations & Maintenance phase (NIST, 2004). One of the study's conclusions is that "an inordinate amount of time is spent locating and verifying specific facilities or project information that come from previous activities." (NIST, 2004).

According to several studies (Bayar, Aziz, Tezel, & Arayici, 2016; IFMA & IFMA Foundation, 2013), the chart below summarizes the overall potential of the BIM methodology, which provides for an ideal increasing of information over time thanks to the concept of interoperability. However, this representation is not indicative of the current BIM adoption scenario. From a critical analysis of the building process, the collection of information is much more articulated as shown in the second figure. According to the traditional way of working, the amount of data continues to increase during the construction process, decreasing when the phase changes.

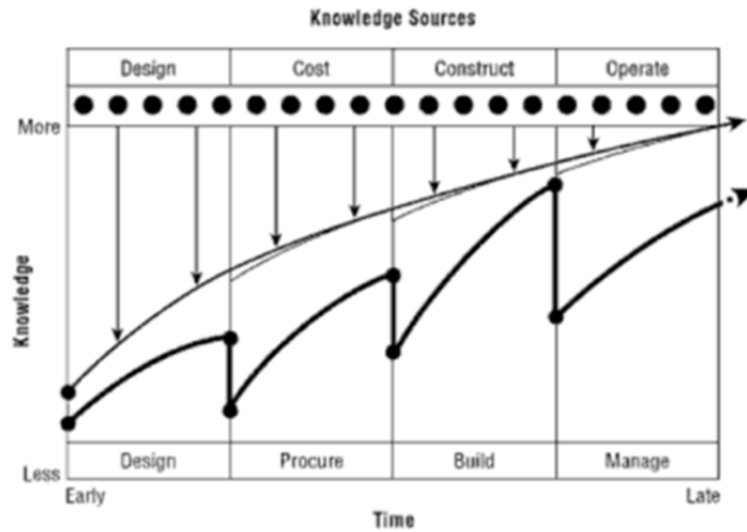

Figure 11: Data lack of information.
Source: <http://bimfix.blogspot.it/2013/05/> (15/05/2017)

The critical period is the handover when the availability of information plummets after reaching the peak, as represented by the black line in the chart. This fact is due to bad storage procedures and management of information that generally is done manually and paper-based. The amount of information is huge but not tailored for upcoming processes and bottlenecks. Consequently, additional costs are required for new data collection, implying a late operation start. Actually the owner should pay twice for the as built information: once for the construction contractor to complete the documents at the end of the construction, and again for the facility maintenance contractor to survey the existing building conditions (East & Brodt, 2007).

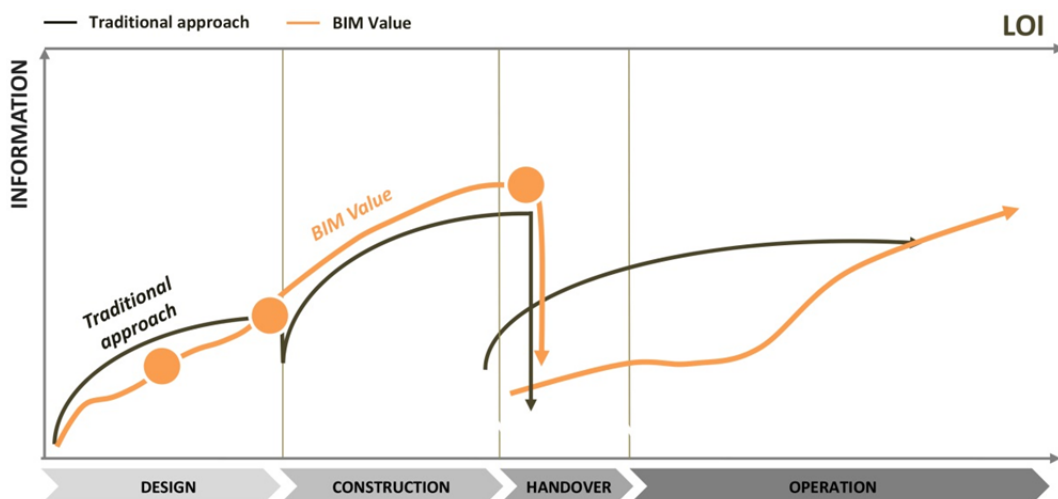

Figure 12: Building process properly involving Facility Management.

With BIM, it is possible to constantly enrich the same model with graphical and non-graphical information among the design stages. In fact, it is “an IT enabled approach that involves applying and maintaining an integral digital representation of all building information for different phases of the project lifecycle in the form of a data repository” (Gu & London, 2010). However, the many stakeholders involved in the building process have very different expectations of BIM outcomes and deliverables. Building owners, architects, engineers or contractors have a very different view of the building. For this reason, the models are developed according to the individual users purposes and this means that the objects are characterized by a different depth of detail in terms of geometry, attributes and information. Although there are valid guidelines that completely define the meaning of LOD, in its dual meaning of Level of Detail and Level of Development, such as those provided by the American Institute of Architect (AIA) (BIM Forum, 2016) and by the UNI 11337:2017 - Part 4 provisions (Stefani, 2017; UNI, 2017), there are usually many difficulties in practicing them, as discussed in the next chapter. This criticality is present in both the design phase of newly constructed buildings and for the management phase in the case of existing buildings. The fact that BIM has enabled a new way of working based on collaboration is not enough to make the construction process efficient if this is used as a mere tool and the information workflow is kept horizontal and consecutive among the stages. According to this approach, it is possible to have several BIM models related to the different stages, as indicated by the blue dots in the previous scheme, or arrive at the handover phase with models that are deficient or inaccurate. Currently, little consideration is given to the quality of BIM models delivered at a project completion so not all of the information is valuable on a day to day basis within the broad range of FM practice. In this case, updating the model may be more expensive in terms of time and work effort than starting again the knowledge process with a new model/system. If the model was not conceived since the beginning with the right approach and the proper settings in the perspective of facility management, it would not be useful and all or most of the information will be lost. For example, a wall with tiles can be correctly represented graphically, but the calculation of surfaces to be cleaned or painted may not be correct. Another issue is the correct recognition of objects at the corresponding level. For a correct BIM that supplies FM needs, it is essential that FM proactively defines the information requirements at the starting point of the project lifecycle, rather than waiting for the project closeout to collect information. Actually stakeholders of the asset data handover have limited BIM knowledge and experience. Therefore there is a clear need to understand better the data requirements for a BIM-based asset management to guide the current handover practices. In fact, recent industry surveys show that the use of BIM is still relatively low both among asset managers and for asset management purposes (McGraw Hill Construction, The business value of BIM for construction in major global markets: how contractors around the world are driving innovation with Building Information Modeling, 2014).

According to my analysis and other studies (Naghshbandi, 2016; Yalcinkaya & Singh, 2014), the major structural deficit and the research gaps are represented by the following issues.

- **The construction industry does not understand FM.** The construction industry requires cultural change to accept FM as part of the process. Traditionally FM is not involved in the construction of a building and there is concern of this separation only in the handover phase, where there are no more interest or optimization possibilities. Additionally, design decision are not usually challenged for their impact on operational cost or maintenance (BIFM, 2012) within futuristic buildings where aesthetic form is considered more important than functionality.
- **Data required and information quality.** To allow the Facility Manager to manage information, reliability, accuracy completeness and updating data are necessary. Successful implementation of FM function depends on the identification of major requirements, function, and communications of the development at the earliest possible time. Actually there is not a correct understanding of which data is required for services purpose.
- **Lack of best practice and guideline.** There are very few practical case studies that show the benefits of BIM for FM (Bocconcino, Del Giudice, & Fabio, 2016; Talamo, La gestione integrata delle informazioni nei processi manutentivi. Dall’anagrafica degli edifici ai sistemi BIM., 2014; Di Giuda, Villa, Eastman, Teicholz, & Rafael, 2016; Ciribini, 2013) often just theoretical. Facility Managers need strong evidence to advise BIM to owners and to collaborate with designers and contractors. This lack is accentuated in the case of existing buildings.
- **Interoperability and data exchange.** Certainly interoperability among software still remains to be strengthened, minimizing the loss of information. The only recognized open standard promoted by Building Smart is IFC, but currently software is not able to correctly display the data structure. Moreover, it is necessary to operate with regard to organizational and procedural interoperability to define a shared framework among the building process.
- **Integration with FM platforms.** Interoperability between BIM technologies and the FM platform is still an issue even though the added value is of undeniable interest. Current FM systems are based on CAD and spreadsheet, so the integration with a graphical database does not have immediate resolution in terms of visualization and correct transposition of data and tables. Moreover, at the moment, it is not clear which information is correct to include in the BIM model and what is more useful, in economic terms and workforce, to insert directly into widely used applications of Computerized Maintenance Management Systems

(CMMS) and Computer Aided Facility Management (CAFM). The Construction Operation Building information exchange (COBie) standard has been introduced as a reference for the transfer of 3D BIM information into spreadsheet format. However, this format is extremely complicated and contains too much information to be included in a model. In addition, the debate concerns who should enter this data during the building process and with what kind of classification.

- **Undervalued economic value.** Probably one of the most critical aspects is that the BIM methodology has started to be cited or required in tender notices, but its value is not recognized in economic terms. In a context where economic deals are down, it is highly unlikely to set valuable processes and tools that can be used throughout the building lifecycle. Professionals are paid for a particular activity. For this reason, the returned models are hardly usable by others. This fact is even more pronounced in the absence of precise instructions from the client.

The key is a process that involves FM from the beginning, ensuring the availability of the right data/information. The importance of robust knowledge sharing between different systems, people, and processes within a project is one of highest priority in such scenarios. As BIM can be the core of the operator's information systems it is necessary that the management experience can penetrate into the previous phases, creating an effective link. BIM has the potential to be the catalyst for efficiency by establishing a relationship between FM and other disciplines. The biggest challenge for BIM enabled FM is to define what information is to be delivered, identify by whom and when the data should be provided.

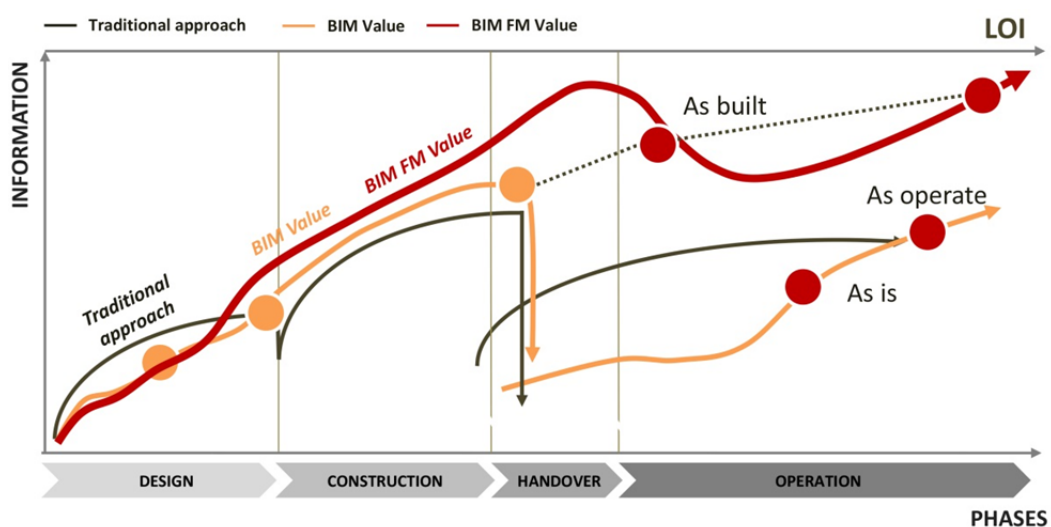

Figure 13: Building process correctly involving Facility Management.

The main benefits of BIM enhancing FM are summarized in the following.

- Facilitating the transfer of data concerning the building from the builder to the facility management contractor. Saving time looking for information and better planning of FM services.
- Optimizing building performance (e.g. space and energy) reducing lifecycle costs through effective asset management.
- Helping users (e.g. maintenance technicians, building manager) to precisely localize facilities and giving them access to their technical documentation and 3D visualization.
- Lowering the operations control and maintenance costs, providing more precise control systems, and consistently delivering cost effective services for the occupants of the buildings (Davtalaba & Delgadob, 2014).
- Fostering augmented maintenance, with gains both in terms of technical operations and performance. Reducing time on technical activities with minimal inconvenience for occupants and operators greater autonomy.
- Integrating data with FM systems (e.g. CAFM, BMS), IoT, and advanced technologies (e.g. AR, VR, 3D printing).
- Giving the owner a real-time vision of the facilities, updated by the operator. Better information about existing conditions reduces the cost and complexity of building renovation and retrofit projects. Improving operation simulation and predictive capacity prior to field interventions.

Considering this potential, a reverse engineering process has been adopted within my study to move from the Building Information Model and Modelling concept to BIM Management process, taking advantage of the maintenance know-how.

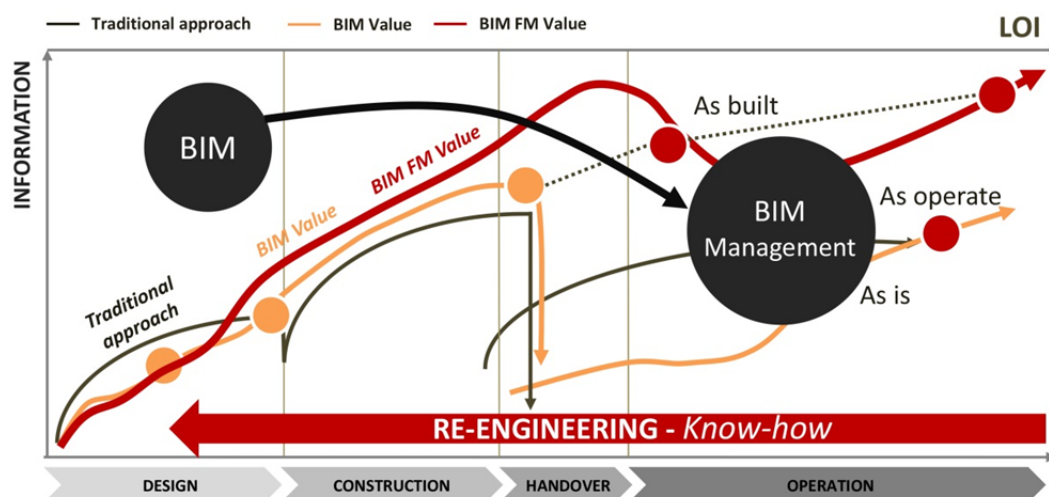

Figure 14: Building process involving BIM.

At this point it is evident that the most effective solution considering the whole process is to set up a BIM model that can be used for Facility Management, regardless of the stage at which it is realized. The value of this application is commonly recognized, but what does it really mean to make a facility management model?

According to my research, there is not a single definition of BIM FM model, but there are at least three possible models: As built – As operate – As is.

Depending on the specific purposes it is fundamental to define which of these is suitable through following criteria that affect the graphics and alphanumeric richness of the model. The initial discriminant is the construction state of the building: new or existing. Subsequently, the complexity of the asset or the consistency of the real estate to be managed is considered.

As built - Complete and detailed model that contains “as constructed” information of all the disciplines. It is only possible if the BIM model is the result of the design and construction phases, properly involving FM. Each object is characterized by all the information available up to that time, including external documents and links with management platform. While information such as technical data sheets of the components are traditionally stored over time, even on paper, one of the most interesting information to collect is performance requirements of components, as defined by the UNI 8290-2:1981 (UNI, UNI 8290-2:1983, 1983). This type of data, usually never available during operations, is valuable as it allows us to know the project design performance of the building in normal condition use providing indicators for maintenance and replacement. As the knowledge of the site is a prerequisite for undertaking maintenance activities, the BIM model can support the preparation of the “Fascicolo del Fabbricato” (Repubblica Italiana, Decreto Legislativo 81/08, Art. 91 and Allegato XVI, 2008) dossier providing a dynamic digital approach rather than just document archiving of information. Considering the large amount of data included, it is necessary to carefully discretise and subdivide the model (see Chapter 4) in order to ensure its manageability being updated. This is a very important issue that can compromise the quality of a model also because of the large size of the file. The As built is probably the ideal Facility Management model but at the same time it requires high costs and development times. It provides the historical memory of the building, including all information from design, construction and management.

As operate - Operational model with advanced but non-detailed geometric representation including elements and parameters needed for Facility Management. It is appropriate for complex buildings, where the spatial and functional relationships of the elements must be monitored. The lack of information that characterizes an existing building is partially offset by the need to represent only the objects to be handled. Although the representation is to be closer to reality, the Level of Information (LOI) of objects is higher than the Level of Geometry (LOG) to establish a consistent database for management. In fact, as

mentioned earlier, the high graphic detail required during design is not necessary to set an existing building model suitable for facility management. If not available, the model contains only information related to visible elements in reality. Systems and technological networks are not drawn. If they are not reliably documented, as they would only result in a waste of time and money. Instead, functional relations such as “is contained in”, “is related to”, “is part of” are essential. In this sense, it is better to know to which electrical panel the switches are connected with respect to their exact position. The model breakdown is central and, being done ex-post, it can be realized taking into account only management principles overcoming the design subdivision of the project. For example, in the case of a high-rise building, it might be more convenient to divide the model in separate floors rather than for disciplines.

As is - Simplified representation of the actual state of the building with a basic dataset of the relevant information useful to start analyzing the asset. Compared to the As operate model, it is recommended for large public or private Real Estate. In these cases, it is better to collect little information easy to update and to obtain comparable data and outputs within the same property portfolio. Using a unified template (see Chapter 4) it is possible to have key performance indicators on quantitative aspects and costs to make comparative evaluations. To be effective, the model must contain information needed to evaluate possible optimization actions on space and energy management. Accordingly, it includes the characterization of the building envelope, the inventory of spaces, and the mapping of system terminals. The objects are reliable in terms of number, size, and qualitative position in the room.

ADVANTAGES	BIM MODEL	DISADVANTAGES
<ul style="list-style-type: none"> • Comparable data and outputs by unified template • Easily upgradable and implementable • Short processing time and cost 	AS IS MODEL	<ul style="list-style-type: none"> • Simplified graphic representation • Basic data-set of information • Objects not visible are not represented
<ul style="list-style-type: none"> • Representation only of the objects to be handled • Management functionalities implementation 	AS OPERATE MODEL	<ul style="list-style-type: none"> • Not comprehensive modeling • Objects not visible are not represented • Medium processing time and cost
<ul style="list-style-type: none"> • Comprehensive modeling of all disciplines • Mapping of all components • Historical memory 	AS BUILT MODEL	<ul style="list-style-type: none"> • Difficulty updating because of its complexity • Not easily manageable operating model • High processing time and cost • Large file size

Figure 15: Advantages and disadvantages of a FM BIM model.

Obviously, this subdivision into categories is indicative, as there may be multiple combinations of typologies of intervention to manage.

From the considerations carried out so far, the application part of the research has been developed. A conceptual framework of the key elements discussed in the following chapters of this thesis is represented in the diagram below.

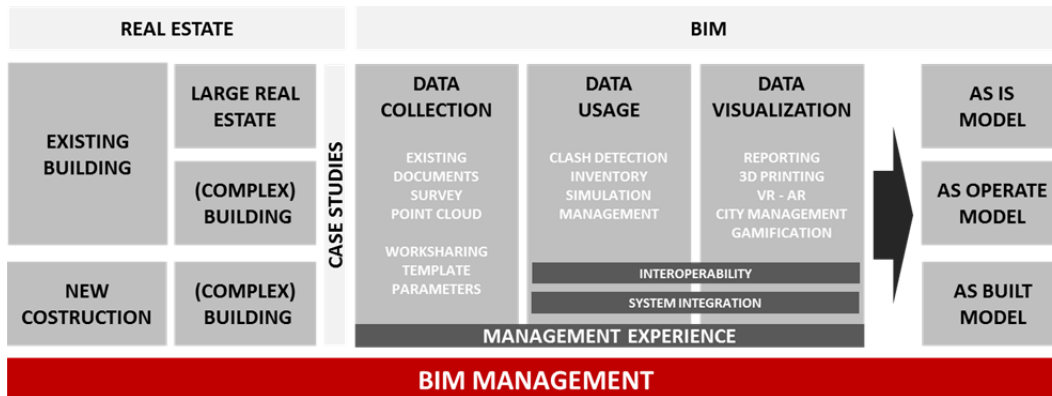

Figure 16: Conceptual framework of the methodology.

The starting point is the smart city and the complexity of the building heritage. Within the scope of digitization it is necessary to explore the connection among buildings, services and the urban environment to obtain a smart data management. Several case studies are selected among different typologies: new/existing, public/private, historical/high-rise complex building, offices/schools, to provide concrete examples. BIM is being investigated as a new frontier of Real Estate connecting people, places and process. Creating a single shared database with management experience gives a tangible value to real estate services, allowing to control all the factors that contribute in determining the profitability of the building: costs, revenues, and quality of services. Taking full advantage of BIM potential, it is applied not only for data collection and organization, but above all, to facilitate their use and visualization at different levels: from the facility manager of the city, to operators and citizens.

Collecting data as well as a site verification check are fundamental steps in order to establish a database for existing buildings. A survey method has been investigated to make the process faster and standardized. However, it is the way information is organized to make the difference and to create added value to the knowledge process. *Data Organization* includes the logical and functional breakdown of the three-dimensional model and the use of shared parameters and a reference template for implementing data according to the stage of the process and the purpose of the modelling. This preparation is often underestimated but is the key to make modeling successful not only in terms of worksharing but of information sharing during the building process.

BIM models are not simple three-dimensional processing, but they constitute multi-dimensional tools that allow more efficient analysis and control compared to traditional processes. If properly defined, the models contain precisely the geometry, the elements properties and materials and their relationships, providing the necessary information to manage the building lifecycle through the different dimensions of interoperability: technological, organizational and procedural (Poirier, Forgues, & Staub-French, 2014). Potential and limits of Building

Information Modelling are analysed to promote a smart digitization process of the building stock. *Data Usage* of BIM model is explored both through internal functionality setting and through data exchange with external applications, optimizing management activities and providing new viewing opportunities for users. Data coming from different sources can be display together by system integration allowing us to strengthen the criteria for the overall evaluation of buildings, including services improvement and optimization and analysis of the city's heritage at building level.

In addition to a tool for knowledge and for managing at the building scale, BIM has been investigated as a logical and informative visual resource to promote the dissemination of information. In fact, BIM combined with new technologies and communication forms allow us to enrich the sensory perception of the built environment and to establish an interaction with the users. The main aim is to test innovative communication possibilities for architecture in order to more effectively reach users and to meet the new needs that technology imposes. *Data Visualization* is tested for both facility management professionals and citizens awareness by adopting different levels of communication. The gamification approach is also used to make complex concepts easy to be understood and correctly educate the “society of the future”.

In conclusion, the adopted methodology leads from “real buildings” to “virtual buildings” by an integrated vision to guarantee the BIM process effectiveness for management activities.

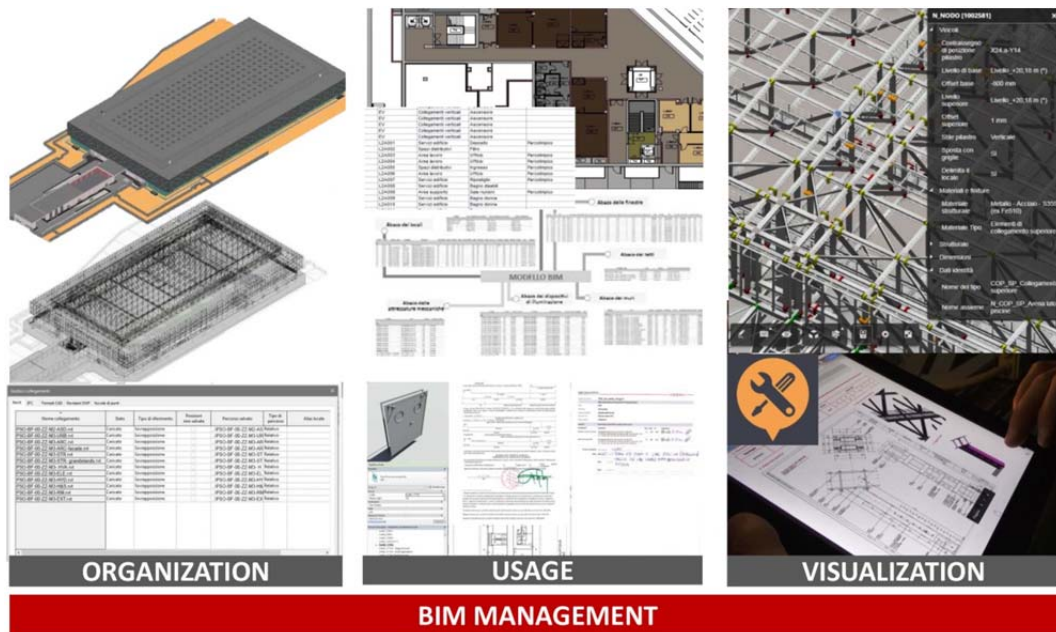

Figure 17: Steps of the operational methodology.
Case study: Pala Alpitour, Turin.

3.2 Case studies identification

The research topic is developed within some representative case studies in order to investigate different aspects of the methodology. The following projects have been carefully selected to test the built heritage digitalization, the interoperability process and data integration as well as new communication methods. These experiences are an essential practical support to evaluate the correct implementation of FM BIM models and to understand how to use BIM data for management in practice.

Digitalization project of the public buildings of the City of Turin (TOBIM)

The goal of this case study is to test the BIM-based digitalization process of the public Real Estate of the City of Turin in order to establish an innovative and integrated system aimed to become a reference best practice both in national and international context. For the first time in Italy, a public administration takes advantage from the BIM methodology potentialities to overtake the traditional CAD approach for a better control of the management process. Its main objective is to set a replicable method for digitalizing and managing the public heritage of the city, starting from survey activities. The main focus of implementations are on energy and space management in order to evaluate possible optimization scenarios. The 30 buildings under investigation are offices, buildings for culture and schools. The As is BIM models constitute a part of the overall management system which aims to interface all the information platforms of the city.

Integrated energy and facility management at Menara TM, Kuala Lumpur

The main goal of this project is to establish an integrated framework for energy and facility management within smart buildings for the Malaysian market. The focus is on identifying the most appropriate instruments to bring together both real time data coming from the Building Management System and quantitative/qualitative information about building to ensure the efficiency of the management process. Menara TM, one of the icons of Kuala Lumpur and the headquarter of the Telekom Malaysia Group, is used to analyse the complexity of skyscrapers. The tower is among the world's 50 tallest buildings with its 77 storeys and 1.6 million ft². The sprouting bamboo shape is by the Hijjas Kasturi Associates and it was constructed between 1998 and 2001. Despite it is a very complex and recent building, the as built documentation is not systematically organized and the information is therefore not accessible. The BIM model pursues the objective to organize the knowledge of the building collecting the main information to streamline management processes.

Zero energy buildings in smart urban districts (EEB)

The project, funded by the Ministry of Education, University and Research (MIUR), aims to increase energy efficiency of buildings, especially at the global level of urban districts. This objective is reached through the pervasive utilization of technologies for a real-time monitoring and control of environmental parameters and the energy production/consumption by the use of smart devices working with a multidisciplinary approach. Settimo Torinese, one of the largest cities of the Turin metropolitan area, has been selected as demonstrator, including public and private buildings. BIM and GIS models as well as sensors and middleware technologies are used for energy mapping and monitoring with the aim of providing consultation tools for city managers and energy refurbishment hypothesis. In this context, the awareness-oriented phase represents a key point for energy-oriented behaviours and for the project dissemination. In particular, the use of AR/AV is intended to be a helpful tool to get a higher level of users consciousness.

UnipolSai headquarters fire engineering

The objective of this case study is to implement the BIM model with the most significant Fire Prevention information in order to use it during the building lifecycle, in particular for maintenance and emergency management. The new UnipolSai headquarters in Milan provides an excellent case study to explain this innovative methodology applied to high-rise complex buildings. The tower building, made of steel, wood and glass, is part of the Porta Nuova district, the largest Italian urban transformation area of the last few decades, and it is spread over 22 floors above ground on a total area of 35.000 square meters. Currently under construction, the complex will house a large auditorium, retail space, and offices.

Pala Alpitour management re-engineering

The goal of this case study is to implement an advanced management model that integrates the asset's knowledge and maintenance know-how according to the latest best-industry practices. It is the first project in Italy that is using BIM for the re-engineering of a post-Olympic site. The activities are aimed at realizing the As operate BIM model of the Pala Alpitour to enable a more efficient and effective asset management. The parametric model of the facility will be configured as the collector of information that can be navigated and queried interactively in order to immediately arrange and represent data as well as to integrate it into other management platforms. The model will also be used as a basis for planning ordinary and extraordinary maintenance work, energy efficiency interventions, and security-related aspects management. The virtual model will also support the management of various event-related configuration and emergency management procedures.

Chapter 4

BIM Data Organization

4.2 Data collection and survey

Searching and analysing the existing information about buildings represents the first stage for digitalizing the city heritage. In this field, “the accuracy and the completeness of the artefact knowledge representation is a key factor that deeply influences the following activities of investigation, intervention and maintenance: in fact, any decision made by the different actors involved is based on ‘what is known’ of the object, and any lack of knowledge or inconsistency can lead to errors and even irreparable damages” (Simeone, Cursi, Toldo, & Carrara, 2014).

Currently the major issues that affect the data management are:

- “as built” hard copy;
- static and not updated building documentation;
- inconsistency of the information;
- multiple versions of digital files;
- no inventory of building assets and components;
- no documentation about the building envelope;
- specific documentation handled by subcontractors and not shared with the ownership;
- large quantity of data coming from different datasets during the building life cycle;
- no correlation between different databases;
- facility activities not managed through an integrated approach.

In this scenario, the potential of BIM is investigated to overcome the inadequate information sharing between the AEC/FM sector, both for decision-making and operational tasks. In fact, parametric modelling allows us to obtain a coherent representation of the actual state of buildings, organizing the available data in an automatic and structured manner with respect to the traditional approach. In the case of built heritage, FM BIM models are the output of an investigation process that includes the collection of all the existing documentation on buildings such as paper drawings, digital documents, or pre-existing models, as well as the use of alternative technique of data acquisition. Depending on the level and quality of the data preservation, the setting of an “Inventory model”, i.e. the model of the starting situation as defined by buildingSMART (Tietoa & Rajala, 2012) can become a critical and complex step within the process. Moreover, the reliability of the data sources is essential to meet the future use requirements of the model. For these reasons, based on the experience gained through the case studies discussed in this thesis, it is necessary to start from an on-site survey in order to collect the most updated information about the existing heritage, achieving, as a consequence, a better management and control of the subsequent proceedings.

The following survey methodology has been developed for the digitalization of the public buildings of the City of Turin (Osello & Ugliotti, BIM: verso Il catasto del futuro. Conoscere, digitalizzare, condividere. Il caso studio della Città di Torino, 2017). In this research, a double objective has been pursued according to the different types of buildings considered. On the one hand, the creation of a preliminary dataset of information is pursued to build and manage the model, on the other hand, the correlation of this data with other applications/systems can enhance energy and facility management activities. Within the TOBIM project, the survey is central for returning a consistent knowledge base and standardized outputs for all buildings, considering the extreme variety of starting documentation. The method can be described by four phases that include: (i) the selection of data to be detected, (ii) the customization of working tools, (iii) the activities in the field, (iv) the final data processing.

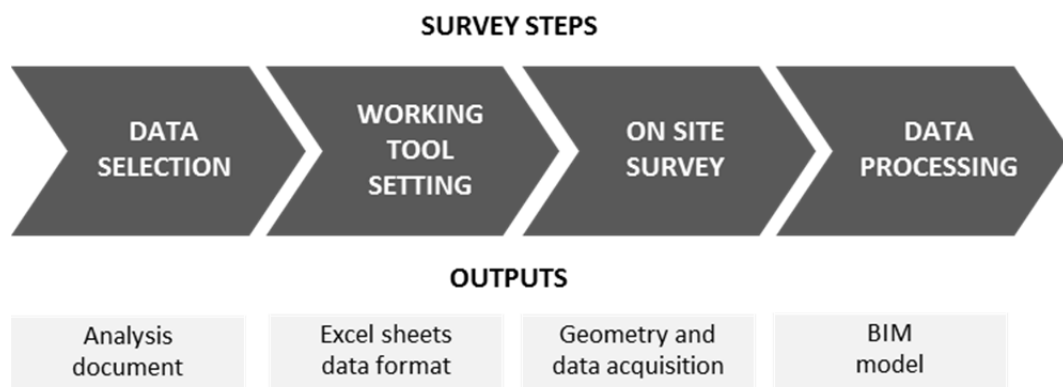

Figure 18: Survey workflow and outputs.

Step 1: Data selection

Depending on complexity, extension and number of buildings, the survey activities require strong analytical and organizational skills to control the process. Moreover, the critical point is to identify the priorities and the hierarchy of the information to be surveyed. It is important to notice that each element detected in field and consequently inserted into the BIM model has to be managed and updated afterwards, in order to make the method effective. Under this perspective, the definition of elements to be collected should be based on a balance between the required accuracy of the representation and the available resources, in terms of time, budget and workforce. It is therefore recommended that the Facility Manager/Department of the building/Real Estate are directly involved in the analysis of requirements. For instance, the information inserted into the models can be used to evaluate different refurbishment strategies or to compare solutions in terms of quantities, cost, price and energy performance, in order to make better decisions based on up-to-date planning approaches. In the same way, being aware of the current state of a building consents the Facility Department to appropriately define the services supply and the maintenance plans based on the real demand of assets and spaces, and adding an important value to the management process. Therefore, the first step requires the collaboration of all players involved in the project for the definition of all the information needed to re-establish the building knowledge depending on the objectives. The output of this phase is an analysis document, in which the information is subdivided into different categories. general features of the building, systems and spaces inventory are the main elements of interest. Within the TOBIM project, a worksheet has been used.

The **building sheet** contains the overall description of the asset (e.g. name, code, use, construction year, floors number, location, orientation, property, cadastral data), the occupancy in terms of number of employees and opening hours of the building as well as the type of documents collected (e.g. drawings, systems diagrams, energy certifications, photographs). The description of the architectural elements is necessary for any refurbishment or efficiency actions, so the building envelope characteristics are checked by analysing typology, thickness, and stratigraphy of supporting structures, floors from ground and to attic, roof and fixtures. It is also useful to map the overall state of conservation of the building and its components. Finally net-gross surfaces and volumes need to be identified.

The **systems sheet** includes general information about HVAC and water supply, identifying generators, refrigerators, pumps, boilers, UTA, by number, type, code, brand, model, year of installation, power. Electrical systems are described by data on electrical panels, lightening devices and significant electrical loads, while mechanical systems from lifting systems. It is appropriate to trace the systems codes and their relative state of maintenance.

The **rooms sheet** is the most important for FM activities such as spaces management and maintenance. The rooms mapping includes the size (e.g. area,

volume, height), the intended use (i.e. category, type), the occupancy (i.e. division, department, employee), and other significant features (e.g. code, accessibility, capacity, presence of vaults, false ceilings and floating floors). For managing, it is necessary to list the type and number of all the components inside the room as fire systems (e.g. fire extinguishers, smoke detectors), electrical and mechanical terminals (e.g. lighting devices, emergency lighting, radiators, fan coil) as well as equipment (e.g. desks, computers, printers).

ELECTRICAL SYSTEM		
ELECTRIC CONTROL CODE OF AFFERENC _____		
ELECTRIC BOARD	<input type="checkbox"/> OF DISTRIBUTION: N° _____	<input type="checkbox"/> OF LOCAL: N° _____
SWITCH TYPE	<input type="checkbox"/> DIFFERENTIALS: N° _____	<input type="checkbox"/> BREAKERS: N° _____
LIGHTING	<input type="checkbox"/> LED	<input type="checkbox"/> OTHER: _____
<input type="checkbox"/> FLUORESCENT TUBES	MODEL: _____	MODEL: _____
MODEL: _____	POWER: _____	POWER: _____
POWER: _____	NUMBER: _____	NUMBER: _____
NUMBER: _____	<input type="checkbox"/> OVA: N° _____	<input type="checkbox"/> OTHER: _____
EMERGENCY LIGHTING <input type="checkbox"/> SI <input type="checkbox"/> NO	POWER: _____	POWER: _____
<input type="checkbox"/> BEGHELLI: N° _____	NOTE: _____	
SIGNIFICANT ELECTRICAL LOADS		
<input type="checkbox"/> COMPUTER: N° _____	<input type="checkbox"/> PRINTERS: N° _____	<input type="checkbox"/> PHOTOCOPIERS: N° _____

Figure 19: Rooms sheet extract.

Step 2: Working tool setting

However, the processed document is too complex to be used in the field quickly and effectively. So, a practical and functional working tool for data collection has been conceived to organize the information in advantageous manner for the BIM model setting, especially for the space inventory. By establishing the necessary information to be taken on survey, it is possible to standardize the process. The worksheet has been organized as a database, so that each row corresponds to a single element detected in the field. According to this approach, the Room sheet has been divided into two separate worksheets. The first includes all space properties, which are converted into columns to be populated systematically, following a logical order from left to right. The sheet can be precompiled before the survey by entering the available information from the existing documentation (e.g. rooms for each plan, code, category, type). The second one contains the list of the equipment in the room, described by their typology, description, size, code, number, power.

Table 2: Example of room worksheets.

Asbestos		N	N	N	N
Heated		Y	Y	Y	Y
Conditioned		Y	Y	Y	Y
Compartment		N	N	N	N
Occupants		2	0	0	0
Capacity		3	30	0	0
Extension		Plane	Plane	Plane	Plane
Floating floor		N	N	N	N
Pitched roof		N	N	N	N
False ceiling		Y	Y	Y	Y
Vault		N	N	N	N
Height		3,39	3,39	3,39	3,10
Open to public		N	Y	N	N
Accessible		Y	Y	Y	Y
Service		Archive..	Archive..	Archive..	Archive..
Management Area		-	-	-	-
Direction		Culture...	Culture...	Culture...	Culture...
Type		Office	Meeting	Toilet	Corridor
Category		Working	Support	Service	Auxiliary
Name		Manager	A		
Zone		1	1	1	1
Existing Room Code		1	15	-	-
Room Code		1001	1015	W105	X001
Floor		XPTE	XPTE	XPTE	XPTE
Building code		CE109	CE109	CE109	CE109

Power		4X18W	1X18W		
Number		6	1	2	2
Dimensions				58x50x10,5 cm	
Code			11		
Model			Beghelli		Ventilima
Type		Square ceiling lamp	Linear ceiling lamp	Cast iron 13 elements H 50 CM	Battery 55x55 cm
Equipment		Fluorescent tubes	Emergency Fluorescent tubes	Radiator	Fan Coil
Room Code		1001	1001	1001	1001
Floor		XPTE	XPTE	XPTE	XPTE
Building code		CE109	CE109	CE109	CE109

Codes are assigned to buildings, floor plans and rooms to univocally identify them. It is very useful to establish since the beginning the registry building structure, in order to use the same approach for all phases of the process (e.g. survey sheets, BIM models, facility management platform). It is advisable to start numbering the rooms on each floor and always follow the same distribution logic (e.g. from left to right, following the shape of the building). The progressive of the room can be anticipated by a letter so that its function is highlighted, as shown in the table.

Table 3: Floor plans and room codes example.

FLOOR CODE		ROOM CODE		
XS02	Second basement floor	0	0001	Generic room
XS01	Basement	X	X001	Distribution area
XPTE	Ground floor	W	W001	Toilet
XP01	First floor	A	A001	Lift
XP02	Second floor	C	C001	Shaft
XP0n	Nth floor	S	S001	Stairs
XPCO	Roof floor	E	E001	Outdoor area

Using these worksheets allows us to record the survey data directly on a digital support, avoiding the use of paper and the lack of understanding of what has been written. The tool can be set through a simple Excel worksheet, but also through a database or Google sheets. In the last two cases, more people can populate the same file at the same time, but an internet connection to the server or cloud is required. This mode is therefore considered as a possibility to be evaluated depending on the case, as it is not always possible to have internet coverage during the surveys (e.g. underground floors, buildings not occupied by offices). In order to make an effective survey, other working tools are needed such as multiple copies of scaled paper plans, yardsticks and distance meters as well as device such as tablet or computer.

Step 3: On site survey

Tools and drawings prepared in the previous step are used to verify in the field geometry and gather the information. The optimal survey team consists of three people in order to quickly and successfully carry out all the activities. Each room needs to be examined in terms of its geometrical characteristics, attributes and photos. In the case of large size building or limited time available, it is convenient to organize multiple survey team that can operate simultaneously on different floors/areas of the building. The working tool as well as the standardized information format ensures the reproducibility of the survey method among the different teams or projects. In any case, it can be useful to tag the survey sheets with the name of the operators and the date of the survey to match them easily.

The **geometry** of the building is the essential starting point from which to implement the BIM database. Considering that archive documentation may be incomplete and/or non-updated, making a proper survey allows us to overcome the inconsistency among drawings or different versions of the files. From CAD drawings, the general measurements need to be verified both on planimetric (surface) and altimetric (volume) levels, through the use of laser distance meters and traditional instrumentation. In addition to the maximum dimensions, diagonals must be checked, especially in the case of historic buildings. Most of the time, prospects and sections drawings are not available, consequently this fact complicates its three-dimensional representation in the modelling phase. Such problems can be solved by the use of indirect survey techniques for visible surfaces data collection such as image-based modelling and laser scanner. The latter is only recommended for very detailed insights on individual buildings or for the reconstruction of the historical-artistic heritage, as it involves the return of a considerably high and unmanageable amount of information as well as having a significant cost. The image-based modelling technique, instead, uses the principles of photogrammetry for the realization of three-dimensional metric models by means of two-dimensional digital photographs. The photos have to be meshed with appropriate software for the creation of a consequent point-cloud (e.g. PhotoScan), which can be imported into the modelling program.

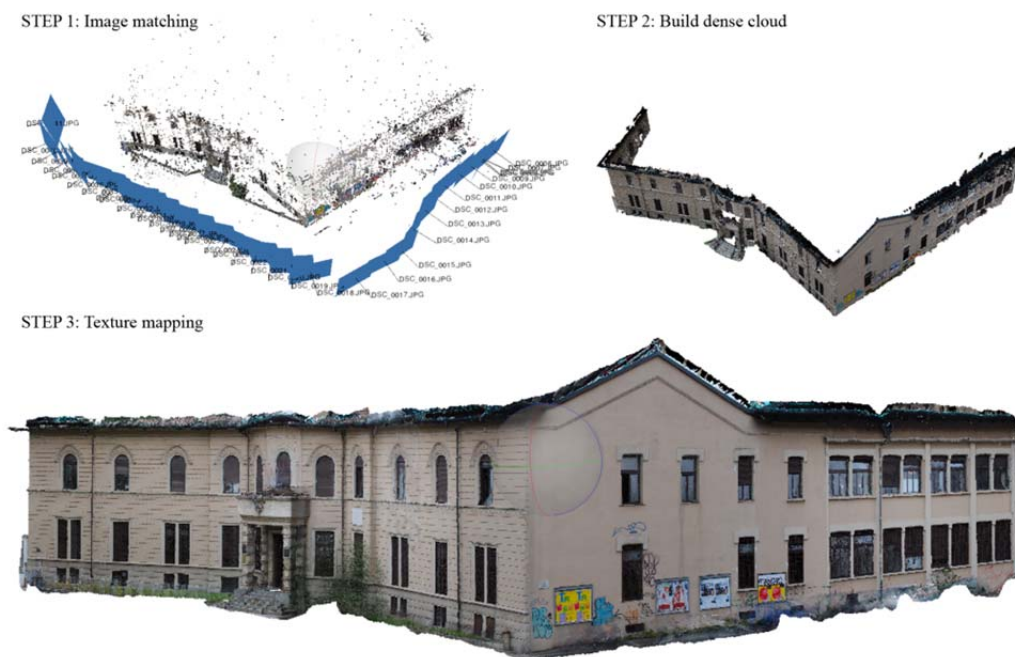

Figure 20: Point cloud realized with PhotoScan.
TOBIM project. Case study: Corso Ferrucci 122.

Once there, it can be placed in the proper position and used as a reference to obtain or check relevant dimensions of the building that otherwise would require especial resources in the field. In this way, information about heights, distance between levels or maximum external lengths can be captured.

In addition to the geometric measurements, the other **data** detected in field are mostly related to management such as occupancy and intended use, equipment and terminals as described above. For energy purposes, great attention has to be paid to the definition of the building envelope, detailing elements that have a significant impact on simulations, such as opaque and transparent components, according to a standardized format. The information on stratigraphy and materials of components must be collected, if possible, or estimated in the field to allow a preliminary diagnosis.

Step 4: Data processing

Data from survey and the existing documentation are the starting inputs for the creation of the BIM model. The geometric measurements allow you to create the physical container that is then enriched with the information gathered in the worksheets described above. As output, the model returns a coherent representation of the building in all its parts, which can be viewed through themed views as well as schedules of components and equipment. Thanks to the database format used for data collection, the information characterizing the spaces can be imported to automatically populate model parameters. To do this, it is necessary to define rooms, encode them, and set up a schedule containing all the parameters of interest. Through appropriate plug-in the schedule can be exported and integrated quickly with the data contained in the spreadsheet.

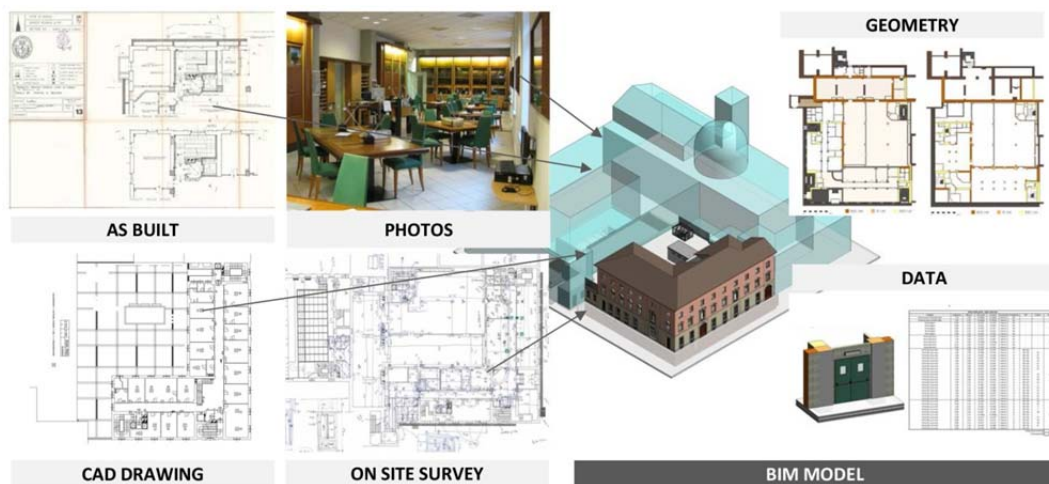

Figure 21: BIM model definition from survey and existing documentation.
TOBIM Project. Case study: Archivio Storico della Città di Torino,
modelled by Aitana Marcos Guinea.

As can be seen from the table below, the starting documentation of the TOBIM project's case studies was poor, characterized by a general inconsistency of the drawings, lack of sections and prospects, and not updated. Following the survey and the BIM modelling, an organic and satisfactory level of knowledge was restored, even if through a basic dataset of information, providing a complete, consistent and coherent documentation for all the buildings analyzed. In this way, data can be implemented over time as needed without checking the data every time through targeted surveys. This is only possible if a process of constant updating is activated at the same time as the model is implemented, especially involving the Facility Department and operators.

Table 4: Availability of data before and after the TOBIM project.

TOBIM PROJECT		
	Before BIM	With BIM
Floor plans availability	95%	100%
Elevations availability	20%	100%
Sections availability	10%	100%
CAD drawings consistency	0%	100%
CAD drawings update	10%	100%
Unique data version	30%	100%
System terminals mapping	40%	100%
Windows type	0%	100%
Building envelope characteristics	0%	100%

4.3 BIM model set up

An important element for improving the efficiency of the management process is to determine effective procedures for the collection and organization of information coming from both the design and realization phase, as well as those developed in the different areas of facility management, as explained in the following sections. Autodesk Revit has been selected as reference software.

- **Common Data Environment CDE**

Nowadays the words communication and collaboration have become a very debated topic within BIM, not only among architects, engineers, and contractors but also with owners and facility managers. In fact, according to several studies (McGraw Hill Construction, Interoperability in the Construction Industry, 2007), construction productivity has decreased significantly over the last forty years due to the lack of communication and collaboration about information. This highlights the need to establish a common collaboration system among all the disciplines and players involved in the construction industry. In this direction the BS 1192:2007 *Collaborative production of architectural, engineering and construction information – Code of Practice* establishes a guideline for the construction industry information management aimed at defining disciplined procedures and standards. This method foresees the realization of a “document and data management repository” (British Standards Institution, 2007), called Common Data Environment (CDE), to ensure a perfect management, transmission and quality of the information through iterative development of project documentation. The fundamental requirement to ensure a collaborative approach is to share information from the beginning and to have confidence in the shared data as well as in their originator. Standards are required to ensure the transfer and release of information and documentations in a controlled manner, depending on the stage of proceedings (Work in progress, Shared, Published, Archived). In this way, all subjects have a sharing and archiving environment from which to collect information always consistent and updated through a correctly disciplined, transparent and controllable process. The CDE should be understood not only as a repository of the generated models and metadata, but also as a key tool for effective implementation of BIM as a collaborative process, as introduced by the PAS 1192-2:2013 (British Standards Institution, PAS 1192-2:2013 Specification for information management for the capital/delivery phase of construction projects using building information modelling., 2013). This deepens the issues related to maintenance and asset management in operational guides, as well as the interoperability between BIM and FM software. According to the BIM approach new professional figures like BIM Managers, Coordinators and Specialist as well as a Design Coordination Manager are needed to manage the entire document process workflow.

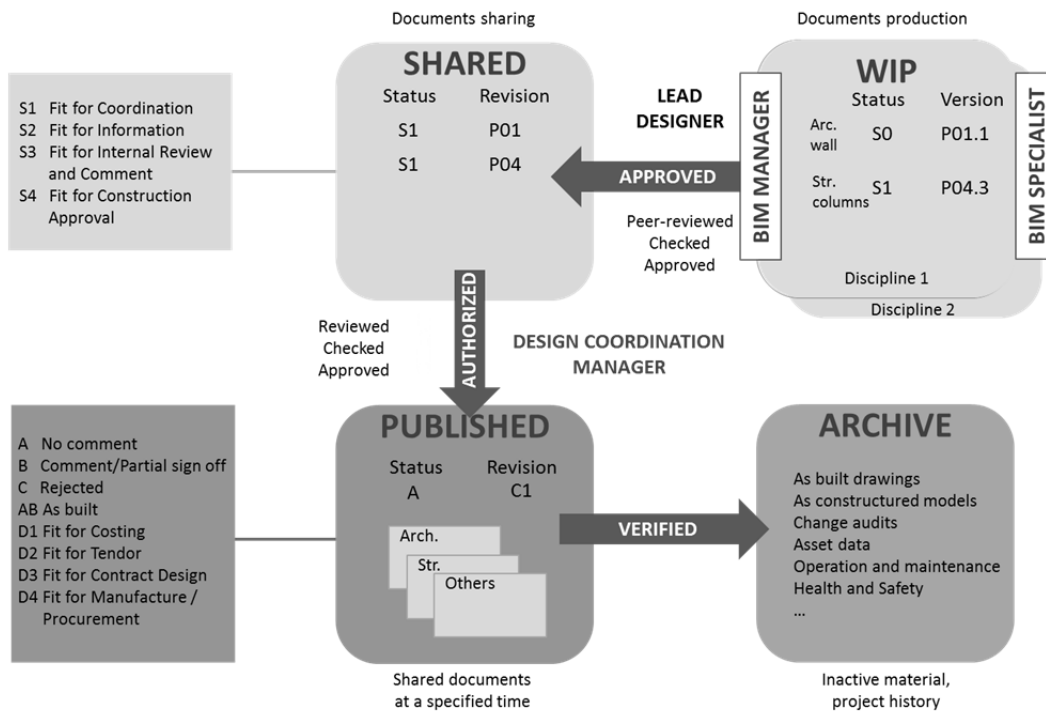

Figure 22: Common Data Environment description.
Source: Re-elaboration of the BS 1192-2 scheme.

According to the BS 1192:2007 common naming conventions and approach, the file nomenclature must include the following types of information: project originator, zone, level, file type, role and number, as exemplified in the image below. This code must also be placed in drawings, so that all the international teams involved can exactly understand their contents and recognize their most up-to-date version.

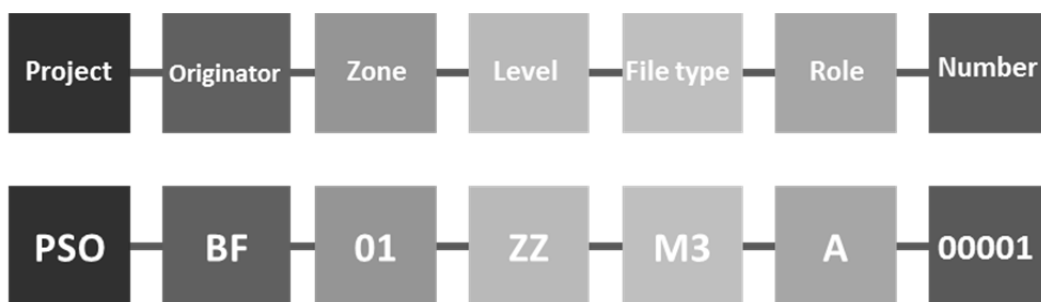

Figure 23: BS 1192 File Naming.

- **BIM model breakdown and work sharing**

The structure of the model, and consequently the database that can be extracted, is a decisive factor for the success of a BIM project and / or for its use for facility management. This structure is based on the integration of several disciplines that contribute to the definition of the virtual building and on the division of work established between the various players involved. For these reasons, the model breakdown needs to be carefully planned before starting modelling, as subsequent variations can be very complex and often result in a loss of information. Hence, different strategies are possible depending on the complexity of the building and its purpose of realization, exploiting functionalities provided by workset and link. However, in some cases, it is also possible to set a single effective project model.

Project model. The use of a single project model is suitable for the creation of not complex buildings in the management phase in order to obtain a manageable As model. Worksharing is not enabled as only one user at a time can work on the model without data replications. It is easy to update and to interface with other applications, providing a simple but effective knowledge tool.

However, the ongoing research for optimization of the building process highlights the adoption of Building Information Modelling as the basis for the application of the concepts of industrial production Concurrent Engineering in the construction sector. **Concurrent Engineering** means the set of methodologies, tools and applications aimed at approaching the design and the subsequent realization of a product in an integrated way. Thanks to a working method based on the simultaneous and coordinated development of the various disciplines involved, it is possible to anticipate the discovery of the critical points of the project, through clash detection, and reduce the impact on time and cost-related changes (Marcos Guinea & SYSTEMA, 2016). Therefore when more project teams or team members have to contribute to the realization of the same project, whether during design or management, it is necessary to set a more complex files architecture to allow a proper collaboration. This fact is essential in particular for design, as it involves roles and responsibilities by individuals and identifies the ownership of BIM data within a diversified work environment. Worksharing is allowed by the use of workset and link in Revit as explained below.

Central model and workset. To allow multiple people to work within the same file, it is possible to save the project file on a network server as a *Central file* and then organize elements through worksets. The Central file is the master project database containing all building model data subdivided into logical areas, while a workset represents a customizable collection of model objects. By associating different model elements to different worksets, the design team has more control over their visibility and properties and can handle project's responsibilities. Each team member works on their own local model version, which can be automatically synchronized to the Central file. This worksharing method allows

each professional to be the owner of the objects and the information that concerns their domain. The other users cannot modify this data, unless by sending a request for modification that can be accepted or not. In a well-set work environment there are elements that must not be modified by individual users but only by the BIM manager, who has the task of controlling, coordinating and assisting design teams. These include, for example, levels, reference grids, and external files linked. In case there is the need to have a model without workset, these can be released, merging them into a single file. This method is the best for the integration of specialties belonging to the same discipline, or for more team members working on different disciplines in the same area. Within a complex project, like an As built, this system is not recommended for the management of the different disciplines because the size of the Central file tends to reach critical dimensions as it acts as a collector, making the project less manageable.

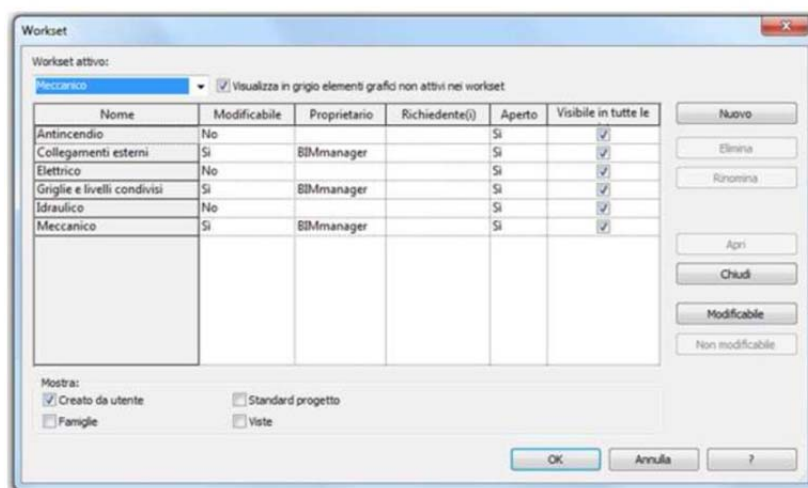
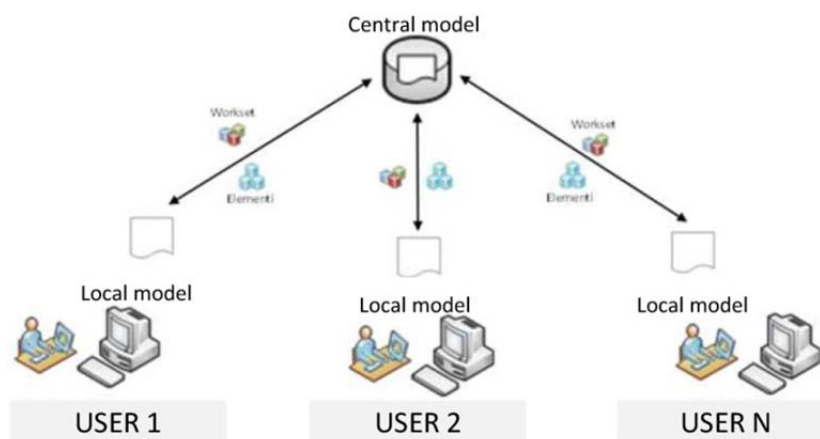

Figure 24: Worksharing through worksets.

Central model and link. Through the setting of links, files connections are allowed to make data of different models available, without weighing the parametric modelling environments. To join two or more files, it is necessary to choose one as the host and link the others, paying attention to the source file location and the type of connection, which may be *Attachment* or *Overlay*. The choice of the reference type is functional to the objective to achieve and specifies whether the nested linked model is shown (*Attachment*) or hidden (*Overlay*) when the host model is linked into another model. It is also possible to define the type of path of the linked file, *Relative* or *Absolute*. In the first case, if the project is moved together with the file attached to a new directory, the link is maintained, while it is interrupted in the absolute case. The link structure provides a smaller file size than worksets, resulting in increased software and hardware performance. The subdivision of the model can be made according to the different disciplines or to particular requirements dictated by the work or the building. For example, as mentioned earlier, it may be convenient to divide the model into floors in the case of high-rise buildings. Even with links, if necessary models can be joined into a single file. Furthermore, worksets can be applied to each Central model to enable a further division of the work.

Table 5: Summary of the breakdown strategies of a BIM model.

	BREAKDOWN STRUCTURE		
	PROJECT FILE	WORKSET	LINK
FM BIM Model	As is	As operate (a) As built (b)	As operate As built
Building type	Non complex building	Complex building (a) Non complex building(b)	Complex Building
Users	1	>1	>1
Advantages	<ul style="list-style-type: none"> - Asset overall representation into a single file. - Single user's objects ownership. - Easy to upgrade. 	<ul style="list-style-type: none"> - Automatic changes synchronization. - Real time worksharing - Organization elements flexibility. - Changes and elements ownership check. 	<ul style="list-style-type: none"> - Smaller file sizes. - Lower software processing time. - Real time worksharing - Independent but coordinated disciplines. - Greater flexibility during management.
Disadvantages	<ul style="list-style-type: none"> - Single file for all disciplines. - Worksharing not allowed. 	<ul style="list-style-type: none"> - Large file size - More advanced hardware/software tools needs. - Difficult conversion to a link-based structure. 	<ul style="list-style-type: none"> - Complex architecture. - Possible need to links re-set. - More articulated views and schedules display. - Manual changes synchronization. - More advanced hardware/software tools needs.
Process phase	Management	Design/Management	Design/Management

As part of this research, a **file system architecture** has been developed for Revit parametric models, according to the AEC (UK) BIM Technology Protocol (AEC UK, 2015), in order to achieve the workflow optimization. Regarding this, a data processing structure has been defined to promote the sharing of information between the various disciplines/actors of the building process. This is relevant, in particular, to solve the interaction and interference. This structure provides the use of **Central models** for all the individual disciplines involved and **Local models** dependent on centrals, divided by specialty through the use of worksets. The Central models are connected to each other through links in order to make available updates to other design disciplines, moving toward the integrated process. In particular, the Central files are connected to empty files, defined **Transfer**, which have the purpose of transferring the information avoiding loops of cross-references, which make the structure unusable. Lastly, to have an overall view of the project, all information is combined through links to the **Coordination** file. The subdivision of model in different files is conceived in relation to the professional skills that operate on them during the building lifecycle, pursuing an organic information exchange.

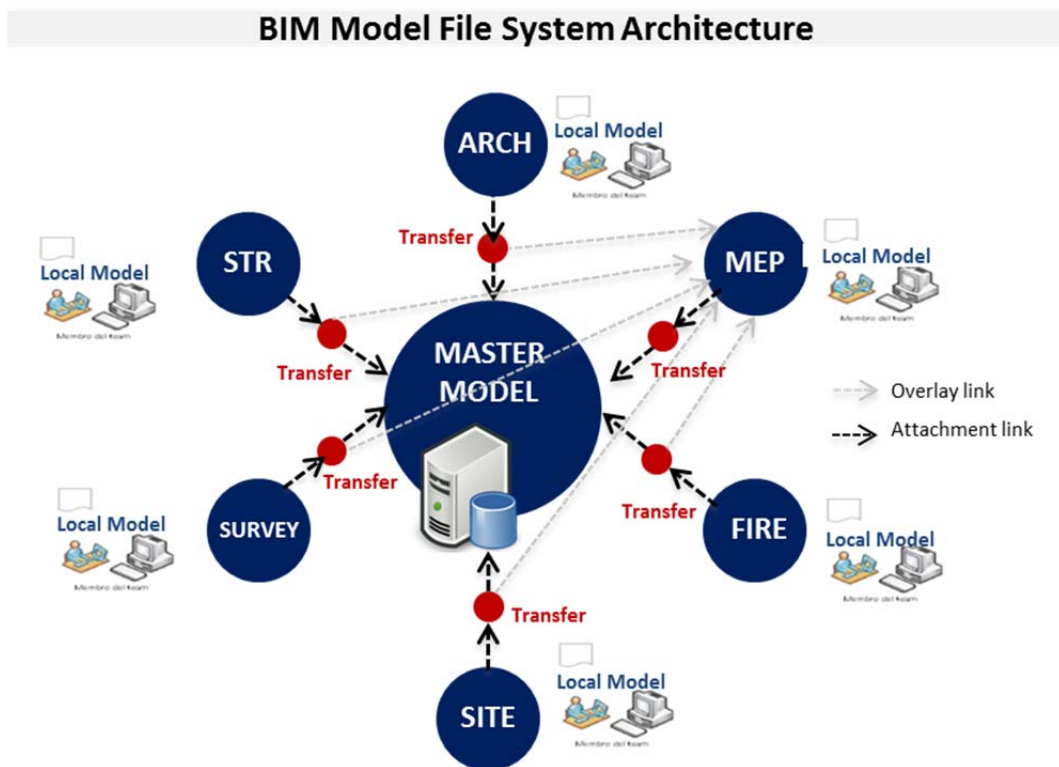

Figure 25: File system architecture example.

In fact, by adopting the illustrated framework, it is possible to implement a collaborative process that, although simplified, meets many of the concurrent engineering requirements. From a practical point of view, the method is allowed through the use of a network map appropriately and uniquely identified (es.Z:\BIM\PSO o dropbox). To ensure that all actors involved can access the files architecture, it is necessary to duplicate the folder structure on the server on each local machine, using the same name as the network map originally created on the server. In this way, the changes made on the single files are made available to the other actors involved in the process every time the file is synchronized within the architecture placed in the server. The synchronization frequency of files is established by the BIM Execution Plan or in the absence of this by the parties. It is obtained through manual coordination activities, but can be automated by using backup software or cloud systems.

The following table shows the link settings depending on the different model types included in the file system architecture. Central models are associated with the Transfer files using *Attachment* reference, since the latter must transfer the information of the files to the Coordination file. While Transfer files are connected with Central models by *Overlay* links to avoid cross-references and to not duplicate the information in the Coordination file.

Table 6: Model connection specifications.

LINK	REFERENCE TYPE	PATH TYPE
Central Models – Transfer (Host Model)	Attachment	Relative
Transfer – Central Models (Host Model)	Overlay	Relative
Transfer – Coordination fil	Attachment	Relative

This structure allows us to work autonomously on separate files, and to display other users' modifications (even if notifications are not enabled). However, to get a comprehensive representation of the database, it is necessary to set themed or filtered project views and elements schedules directly into the Coordination file, as this kind of settings are not automatically transferred. During this procedure, particular attention should be paid to the use of the Revit *Phases*, so that the elements belong to the same phase. Then phases between various disciplines and the coordination file need to be made congruent through the correlation of the equivalent phases. In addition, in order to correctly display elements coming from linked files in schedules of the Coordination model it is necessary to include them in connection through specific functionality of the schedules settings. Even levels and grids must be a separate central model in order to be used as a link reference for all other models.

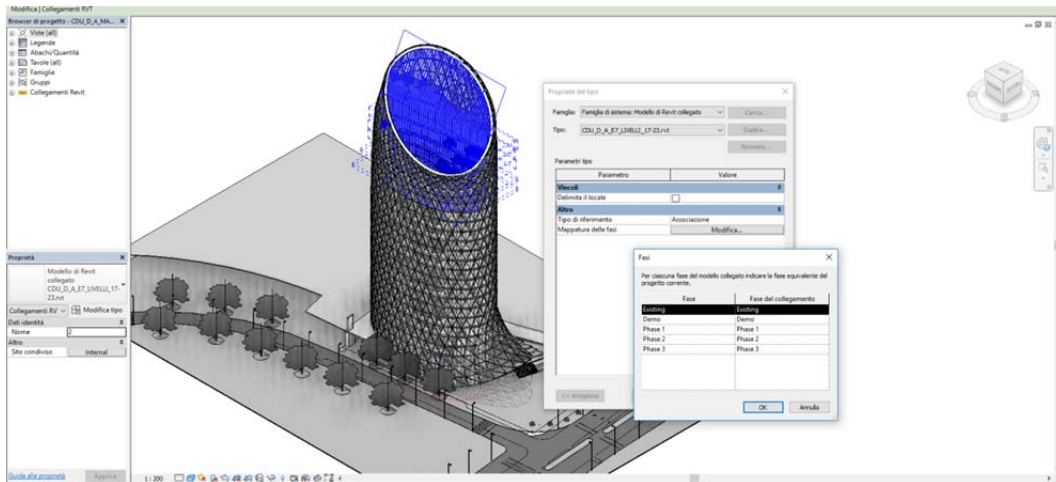

Figure 26: Matching of the equivalent phases between files.

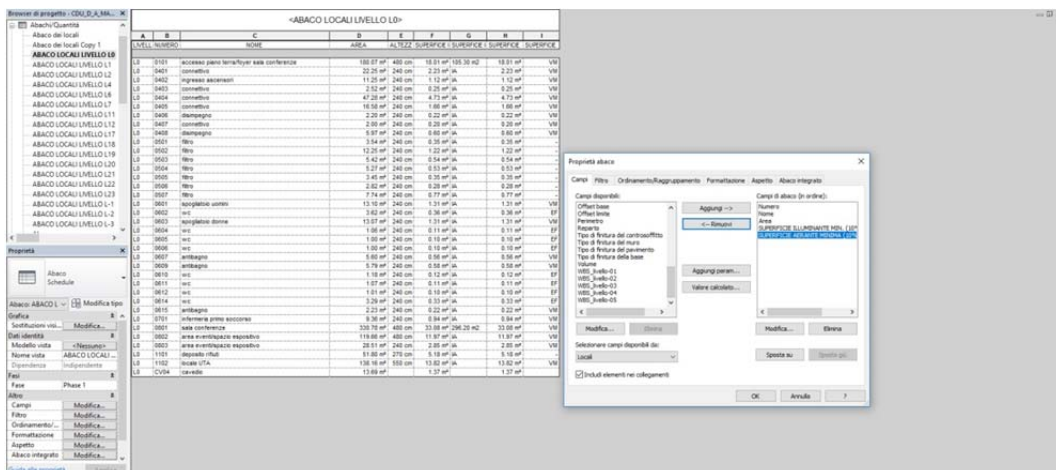

Figure 27: Inclusion of objects from linked files in Coordination schedules.

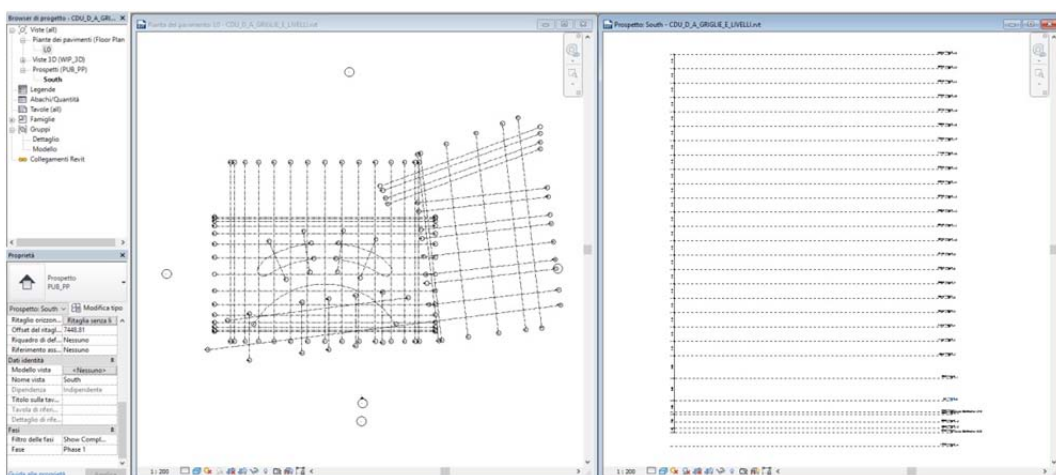

Figure 28: Level and reference grid as a separate Central model.

Below is the breakdown of the model adopted for the implementation of the Turin Pala Alpitour As operated model. Specifically, the data structure is divided into the following Central Models, corresponding to the same number of Transfer files and coordinated by a single Master file.

As built CAD:	PSO-BF-00-ZZ-M2-ASD
Urban context:	PSO-BF-00-ZZ-M3-URB
Architecture:	PSO-BF-00-ZZ-M3-ARC
Facade:	PSO-BF-00-ZZ-M3-ARC-facade
Structure:	PSO-BF-00-ZZ-M3-STR
Grandstands:	PSO-BF-00-ZZ-M3-STR- grandstands
HVAC:	PSO-BF-00-ZZ-M3- HVA
Electrical system:	PSO-BF-00-ZZ-M3-ELE
Hydraulic system :	PSO-BF-00-ZZ-M3-HYD
Health and Safety:	PSO-BF-00-ZZ-M3-H&S
Room:	PSO-BF-00-ZZ-M3-RM
Outdoor installations:	PSO-BF-00-ZZ-M3-EXT
Level and grids:	PSO-BF-00-ZZ-M3-LEV

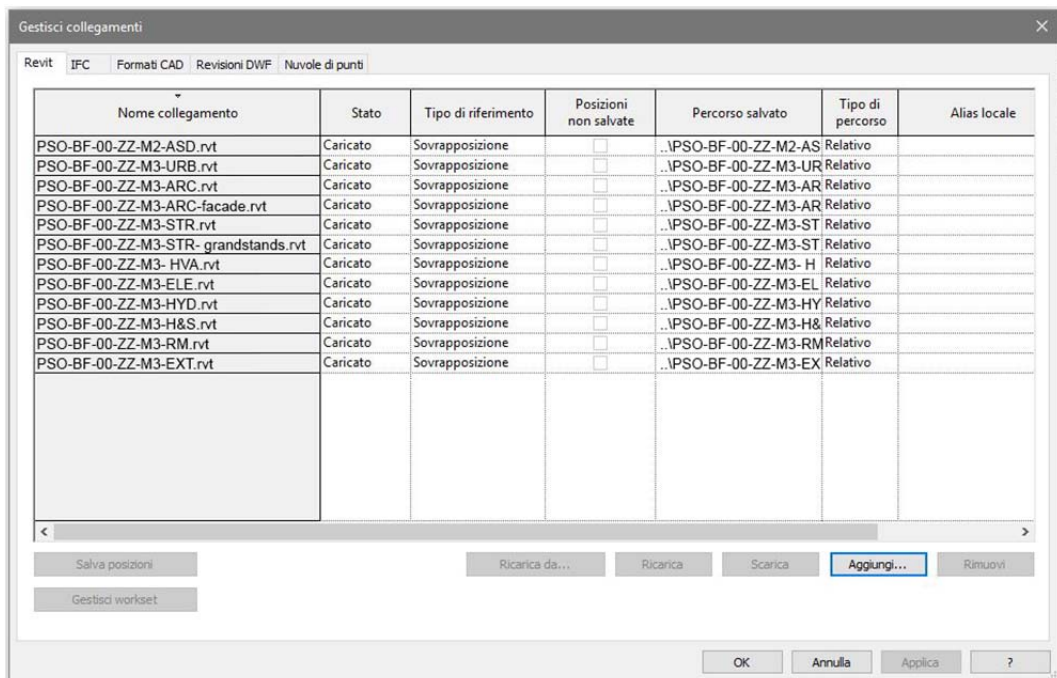

Figure 29: Pala Alpitour linked models example.



Figure 30: Pala Alpitour Central models.
Case study: Pala Alpitour, Turin.

- **Template**

A shared and standardized language is required to achieve a unique system within different players or to analyse different buildings. As stated by the Autodesk Knowledge Network (Autodesk Support, 2014), the creation of a *Template* is fundamental to optimize the effectiveness of the project performance. Based on the experience gained through the case studies developed in this research, it is necessary:

- to load all the families that will be used frequently in the project (e.g. doors, system terminals, equipment);
- to create the needed project parameters recalling the previously defined shared parameters for all families;
- to include few types of walls specifying the turning mode of the layers;
- to set standard schedules for the building registry including shared parameters;
- to set some drafting views;
- to use the *Transfer Project Standards* in order to compare and import elements from one template to another;
- to update the templates to the latest Revit format before starting a new project.

The use of a Template is good for all BIM FM Model and can be used according to the final objectives of the project. For complex buildings, in the case of as built models, the template is developed by BIM Manager in order to establish the general settings and modeling rules providing all players of an effective working tool that includes all the parameters required by project output. If the model is implemented during the operation phase, As operate/As is, the Template aims to collect all the information required by the Facility Manager to be included in the management database. In addition, the Template is an efficient way to get data and output fully comparable in the case of multiple buildings or large Real Estate.

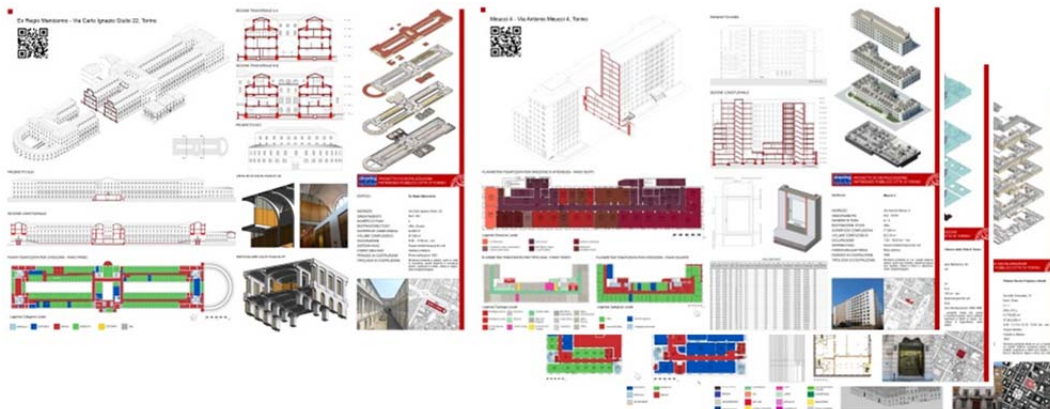

Figure 31: Comparable output of the TOBIM project.

As an example, within the TOBIM project (Osello & Ugliotti, BIM: verso Il catasto del futuro. Conoscere, digitalizzare, condividere. Il caso studio della Città di Torino, 2017), the setting of a common template for the 30 case studies analysed has allowed to obtain data, schedules, and themed floor plans characterized by the same structure and format. This approach enables us to organize data in a coherent way for each building, while at the same time they can be queried in a transversal way to make comparative cross assessments by the City Manager on the public heritage.

- **Creation of BIM models with proper LODs**

As BIM provides an enormous amount of information, it is essential to define specific standards for both data contents and graphic information. The definition of these standards is intended to enhance the optimal use of BIM data by stakeholders involved in planning, design, manufacturing, management and maintenance. To meet this need, the American Institute of Architects (AIA) has introduced the double meaning of Level of Detail and Level of Development (LOD) to define a common graphic representation of components and their related metadata. The *Level of Development Specification* is a “reference standard that enables practitioners in the AEC industry to specify and articulate with a high level of clarity the content and reliability of BIM data at various stages in the design and construction process” (BIMFORUM, 2016). This utilizes the basic LOD definitions developed by the AIA for the AIA G202-2013 Building Information Modelling Protocol Form (The American Institute of Architects, 2013) and it is organized by CSI Unifomat 2010 (Construction Specification Institute). It defines and illustrates characteristics of model elements from different building systems at different levels of development/detail. “Level of Detail is essentially how much detail is included in the model element. Level of Development is the degree to which the element’s geometry and attached information has been thought through – the degree to which the project team members may rely on the information when using the model. In essence, Level of Detail can be thought of as input to the element, while Level of Development is reliable output” (BIMFORUM, Level of Development Specification 2015, 2015). Depending on the expected uses (analysis, costs evaluation, plan and coordination) the reliability of the elements and the amount of information to be included in the building information model are defined from conceptual representations (LOD 100) to the construction documentation (LOD 400).

At the national level, however, LODs are declined by the recent UNI 11337:2017 - Part 4 *Building and civil engineering works - Digital management of building information processes* standard (UNI, UNI 11337-4:2017, 2017). The definition of this standard marks a significant step within the BIM processes, also in relation to the New Italian Procurement Code that introduces methods and tools that use interoperable platforms within the framework of the public administration and

construction sector digitalization strategy (see D.lgs. n. 50/2016, art. 23, paragraph 13). Unlike the LODs provided by AIA, those promoted by the UNI are identified by letters and provide for a greater articulation, which also includes new references to reuse and restoration activities (i.e. LOD F, LOD G), stimulating new debates in the European BIM table. Also in this case, a BIM oriented project is characterized both by the graphic information (LOG) and the attributes (LOI) that the objects must contain.

LOD A	LOD B	LOD C	LOD D	LOD E	LOD F	LOD G
Symbolic object	Generic object	Defined object	Detailed object	Specific object	Executed object	Updated object

Figure 32: Articulation of LODs provided by the UNI 11337.

As mentioned above in the methodology, there are usually many difficulties in practicing LODs. In particular, since it is not so correct to define a representative Level of Detail/Development for the entire building, as each object can be characterized by different LODs depending on the available information and purpose, especially in existing buildings. The use of these two different concepts defines at the same time strengths and weaknesses of the method. In fact, as well as detected by other (Rizzarda, 2015):

- (i) it is difficult to understand precisely the design phase of a certain element;
- (ii) it is easy to misinterpret the precision with which an item has been modeled, as a provisional model may appear detailed as much as a model in the execution phase;
- (iii) it is equally easy to extract from a BIM model the data that the author does not intend to use and therefore has not kept control (e.g. volumes, thermal transmittance of materials);
- (iv) it is crucial that the user knows which information of the model can be used.

In conclusion, as far as a parameter can be compiled, it is not necessarily reliable for the model. To overcome this problem, public or private client can defined in the initial stages of a BIM project an *Employer's Information Requirements* (EIR) document which indicates the minimum requirements to be included in the project in relation to the specific project. This document serves to define the information requirements in technical, management and commercial areas of a BIM project. Despite EIR is a tool that allows the client to make specific requests with respect to the BIM model development, the inclusion of it in the tender documents is not widespread as it requires high level of expertise and deep knowledge of tools and working methods to produce it. For these reasons, at national level, no well-developed examples are available as reference. Consequently, it is more common

today that only the BIM Manager describes the model's information content through the *BIM Execution Plan* (BEP). It accurately illustrates the LOD that each of BIM authoring discipline will ensure in the established deliveries, as suggested by the UK PAS 1192-2:2013 (BSI, 2013). It manages procedures such as *How does geometric modeling evolve through the various phases?*, *Who inserts the object into the model and at what stage?*, *Who specifies model and manufacturer?*

Furthermore, the use of LODs as a measure of project development is another critical issue, especially for the Italian scenario with three separate design levels (concept, preliminary detailed, detailed design project) and graphic standards of drawings based on CAD practice. At present, the graphic and informational content of a BIM model is not regulated or uniquely defined. This favours the margin of discretion of the modeller and the possibility of appeal in tenders. According to the ruling of the Lombardy Regional Administrative Court (TAR) of 29 May 2016, in fact, in the absence of specifications by the client the attention should be paid to the concept of information rather than to the method of representing individual objects. "The basis of the project is certainly a three-dimensional model, but that does not mean that every object should be mandatory three-dimensional." (N. 01210/2017, 2017) as the relevant issue is the working and digital representation method instead of a "BIM Format".

Moreover, in accordance with the concept of LOD, the application of a high level of graphic and informational detail corresponds to a use for facility management. Nevertheless, according to my research, this concept is not suitable for existing buildings, where the information available can never be as detailed as in the case of a new construction BIM model. In the case of models made during the management, As is or As operate, in fact, it is not convenient to reach a very high level of graphic information, but the metadata associated with the objects are much more important. It is not essential to model all building components: some of them can be represented through conceptual masses, in such a way that they can be identified individually; others can be represented in the model only as textual information associated with their related objects. For example, in the case of a fan coil, it is possible to model only the outside part of the terminal and introduce filter and battery information only as associated parameters. A further case is possible when BIM compliant object created by the manufacturer are used, which may be too detailed according to the phase or the purposes.

Even an object represented by a low level of detail may contain necessary information to Facility Management.

Therefore, it can be stated that it is indispensable to refer to the national and international existing guidelines, but it is appropriate to define the modeling specifications as level of information for each project, especially in the case of As is and As operate models, considering the modeling objective, the available information and budget. From the case studies developed as part of this thesis, a brief overview of the different levels of study used is given.

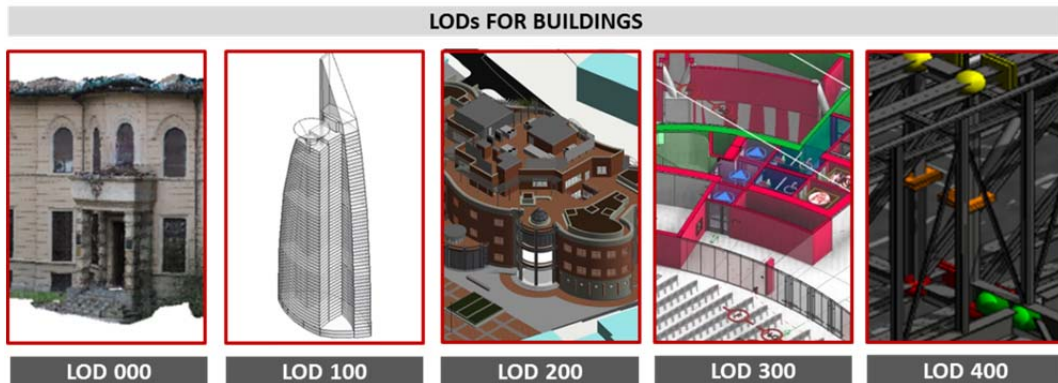

Figure 33: LODs for existing building.

In addition, to provide a real contribution at the city level, the BIM information must be crossed with the Geographical Information System (GIS). This is a great search field of great interest and provides a balance between the different levels of detail characterizing the data sources. Five LODs have been taken into account for the city model within this study (Torabi Moghadam, Lombardi, Ugliotti, Osello, & Mutani, 2016), where LOD0 is the regional level, LOD1 is represented by the three-dimensional view of the public cadastre, which identify data about location and use. LOD2 is made of a simplified building geometry at district level. Such information are mostly related to the GIS environment. While derived from the BIM model, LOD3 is focused on building representation, and LOD 4 introduces detailed information of systems and building components. Through this approach, it is possible to provide information on buildings according to several purposes, such as energy mapping.



Figure 34: LODs for the city heritage.

- **Classification system and codes**

For maintenance and management activities it is necessary to introduce specific information to ensure a proper control of the elements since the beginning of the modelling. In this sense, it is essential to introduce:

- a classification system of all the building components;
- an appropriate coding of technical elements;
- elements description;
- the georeferencing code.

For the integrated management of the BIM model it is useful to adopt the following classification systems, also depending on the model's implementation phase:

- project Work Breakdown Structure (WBS);
- method provided by the local or legislation or international standards.

The numerous alternatives offered today demonstrate a large fragmentation of references, often incompatible with each other, which does not allow a harmonic description of the building system and all the components that together characterize and define it.

The UNI 8290:1981 *Edilizia residenziale. Sistema tecnologico. Classificazione e terminologia* (UNI, UNI 8290:1981-1, 1981) represents the only Italian reference and provides three levels for the classification of the technological system: class of technological unit, technological unit, class of technical element. It is obvious that extension to levels beyond the third, is a practical necessity in most cases.

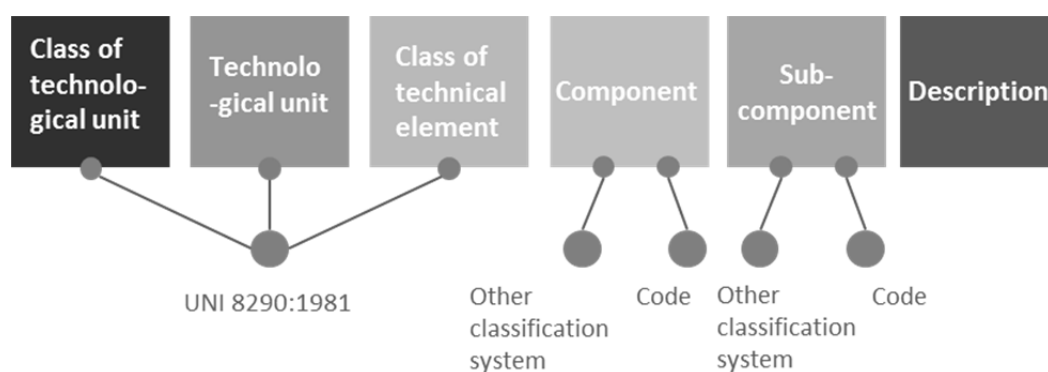

Figure 35: Implementation of the UNI 8290:1981 classification system.

For this purpose, Revit shared parameters can be introduced into the BIM model to replicate the same classification system, implementing the fourth and fifth level in accordance with the criteria set by the regulation. In the absence of a formalized standard, it is possible to use descriptive parameters or codes to identify component and sub-component.

This method, however, is not sufficiently detailed to describe the technology systems. For this reason, other more complete and articulated classification systems have been considered such as the SfB (Vetriani & Marolda, 1983) and the Kraftwerk Kennzeichen System (KKS). The latter defines standardization for the classification of elements forming part of a technological system in order to fully identify the respective parts and components for their purpose, type and location. It introduces three level of code to identify process-relate, point of installation and location of systems components.

Therefore, the three levels of the UNI 8290 classification have been adopted, integrated in the fourth level with the indications provided by KKS, aggregating Total plant, System and Equipment unit codes and the Component code for the sub component, as exemplified in the image.

Table 7: Example of coding a flexible duct using UNI 8210 and KKS.

Class of technological unit	Technological unit			Class of technical element	Component										Sub-component			
					Total plant	System code				Equipment unit code				Component code				
Supply system of services	Air conditioning system			Distribution networks and terminals	Mechanic	Air delivery system				Ducts				Flexible duct				
					M	A	A	A	0	2	A	A	0	0	2	A	B	0

By introducing a classification, it is possible to sort all the building components according to a hierarchical system. In this way, elements belonging of the same class (e.g. technological unit) can be grouped and displayed together in a multi-category schedules, smartly querying the model according to maintenance needs or strategies. Other internationally classification systems are represented by ASTM Unifomat II and Omniclass™ in US, built in BIM environment, and Uniclass 2 in UK.

As far as the single object coding is concerned, Revit, as a database, provides automatic generation of a unique identifier when a new element is created in the model. However, it is appropriate to include an additional alphanumeric parameter for the most significant objects to be maintained with respect to standards adopted by owners within their real estate, by operators or design teams. These elements need also to have a proper description to easily identify them to support the setting of building inventory and maintenance plans.

- **Shared parameters**

As *Project parameters* are not enough to characterize the objects with all the information useful to facility management, *Shared parameters* represent the only way to extend the information about building components in Revit. The use of these has been deeply explored for both optimizing the parametric definition of the models and facilitating the interoperability between different platforms. This mode allows us to enter different types (e.g. text, number, URL, Yes/No) of additional information to multiple families, enriching the ability to query the building database. These attributes can be viewed in the family properties and structured according to typological groups (e.g. identity data, dimensions, fire protection) simplifying their consultation. Shared parameters are stored in an independent .txt file, which can be defined and re-used for multiple families or projects. Compared to the other, information added with this kind of parameter can be displayed in a tag and in schedules. For these reasons, they represent a key element for facility management, allowing the creation of themed views, lists of items rich of information and significant selections of objects, as well illustrated in the next chapter. There is also the possibility to display different family categories within a multi-category schedule thanks to the attribution of the same shared parameter. Moreover, this type of parameters can be exported as an Open Database Connectivity (ODBC) database through specific plug-in, implementing other information systems as outline in a specific section of the *Data Usage* chapter.

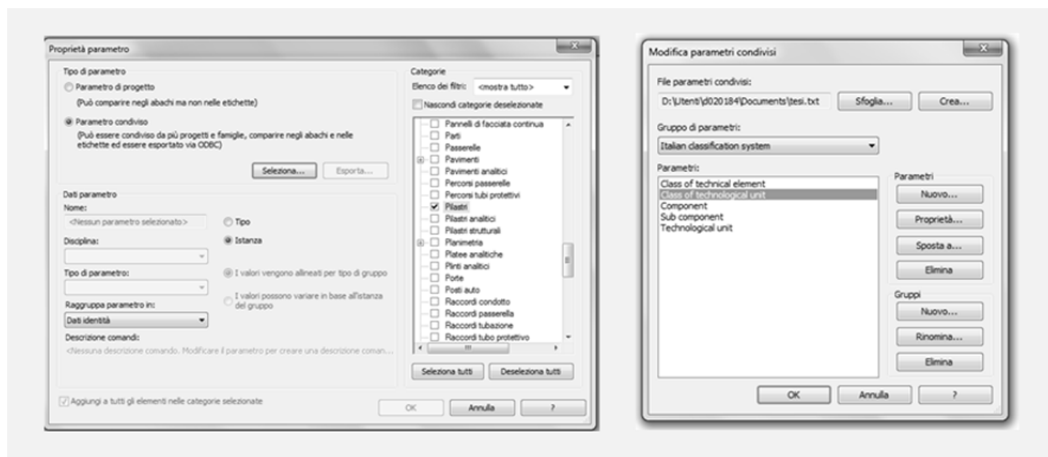

Figure 36: Shared parameter definition.

- **As is model shared parameters implementation**

As an example, the definition of a minimum dataset of shared parameters needed to set an As is model is provided. Moreover, the following parameters have been applied in all case studies developed during this research. In fact, this kind of information is considered highly interesting for managing existing buildings based on their actual situation, as previously identified in the analysis of data to be collected during the survey. According to the specific needs, they can be appropriately enriched and organized as illustrated in the next chapter.

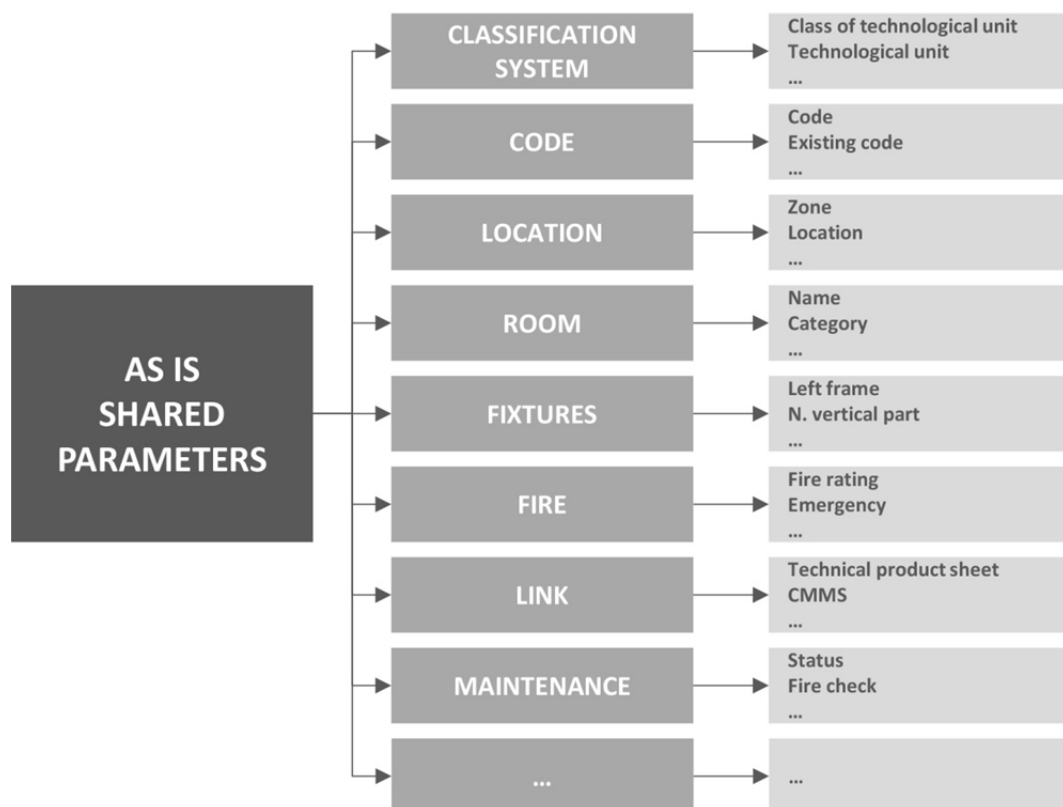

Figure 37: As is shared parameter groups.

Italian classification system

Class of technological unit: [Text] UNI 8290 first level

Technological unit: [Text] UNI 8290 second level

Class of technical element: [Text] UNI 8290 third level

Component: [Text] UNI 8290 fourth level/KKS

Sub component: [Text] UNI 8290 fifth level/KKS

Code

- Code:* [Text] unique identifier of the element (e.g. rooms, windows and walls type, system terminals).
- Existing code:* [Text] identification code used in the past by other coding system (e.g. existing room code).
- Key:* [Text] key number to access/open spaces/elements (e.g. rooms, doors, cabinet).

Location

- Zone:* [Text] subdivision of the space according to functions.
- Location:* [Text] indicates in which portion of the model different architectural and technical components are placed, based on a scheme identified according to the shape of the building. UNI 10951 requirement.

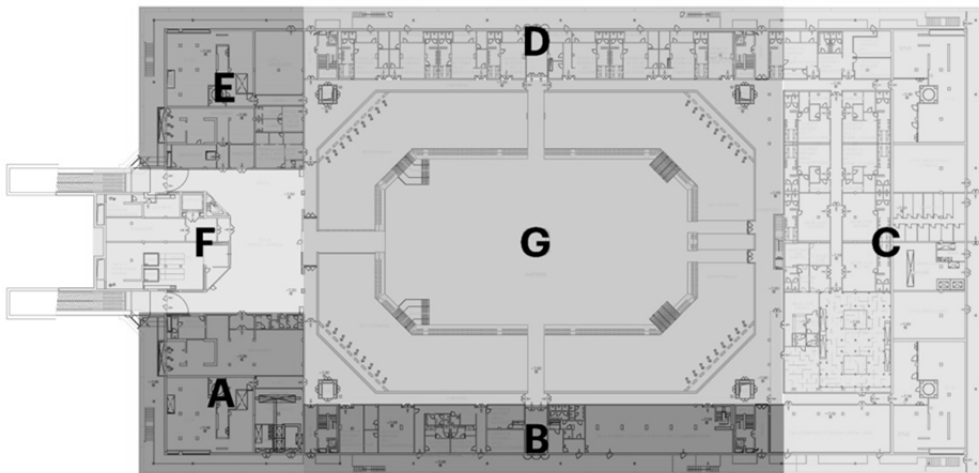

Figure 38: Example of space subdivision.
Case study: Pala Alpitour, Turin.

- Group:* [Text] specifies the membership of an object to a group of objects (e.g. toilet in the toilet block, stairs placed on different levels to the stairway).
- Exposure:* [Text] orientation of all the external architectural components of the building (i.e. North, South, West, East, and their combinations).

Room

<i>Name:</i>	[Text] official name representative of a space (e.g. “Agnelli” meeting room, Classroom 1C).
<i>Category:</i>	[Text] function of the space (i.e. working area, support area, services, vertical connections, distribution spaces, outdoor area).
<i>Type:</i>	[Text] intended use of the space (e.g. classroom, open space, technical room).
<i>Division:</i>	[Text] first level identifying the organizational units/tenants occupying the space.
<i>Department:</i>	[Text] second level identifying the organizational units/tenants occupying the space.
<i>Capacity:</i>	[Number] maximum crowding of the room provided by the regulations and/or systems dimensioning.
<i>Occupants:</i>	[Number] number of people occupying the space (i.e. students, employees, users).
<i>Average height:</i>	Calculated parameter. Volume/area.
<i>Vault:</i>	[Yes/No] presence of vaults in the room.
<i>Pitched roof:</i>	[Yes/No] presence of pitched roof in the room.
<i>Accessible:</i>	[Yes/No] compliance with the Universal Design requirements (e.g. steps height, door width).
<i>Open to public:</i>	[Yes/No] areas opened to public (e.g. public counters, meeting rooms).
<i>Compartment:</i>	[Yes/No] room is a stand-alone fire compartment.
<i>Heated:</i>	[Yes/No] presence of heating in the room due to a terminal or heated enclosed spaces.
<i>Conditioned:</i>	[Yes/No] presence of air conditioning in the room.
<i>Extension:</i>	[Text] room extension (i.e. flat, stairs, mezzanine).
<i>Floating floor:</i>	[Yes/No] presence of floating floor.
<i>False ceiling:</i>	[Yes/No] presence of false ceiling.
<i>Asbestos:</i>	[Yes/No] presence of asbestos components in the room (e.g. ceilings, chimney pipes, roof).
<i>Confined space:</i>	[Yes/No] restricted environment, in which the danger of death or serious injury is very high, due to the presence of substances or hazardous conditions

	(e.g. tanks, spaces with limited or absent ventilation).
<i>Risk:</i>	[Text] risks typology associated with the activities carried out in the room.
<i>Water points:</i>	[Number] presence of water points in the room.
<i>Gas points:</i>	[Number] presence of gas points in the room.
<i>Electrical meter:</i>	[Text] identification code of the meter which provides electricity to the room.
<i>Gas meter:</i>	[Text] identification code of the meter which provides gas to the room.
<i>Water meter:</i>	[Text] identification code of the meter which provides water to the room.

Fixtures

<i>Left frame:</i>	[Length] left frame thickness.
<i>Right frame:</i>	[Length] right frame thickness.
<i>Upper frame:</i>	[Length] upper frame thickness.
<i>Lower frame:</i>	[Length] lower frame thickness.
<i>N. vertical part:</i>	[Number] number of vertical internal partitions.
<i>N. horizontal part:</i>	[Number] number of horizontal internal partitions.
<i>Vertical part:</i>	[Length] vertical internal partitions thickness.
<i>Horizontal part:</i>	[Length] horizontal internal partitions thickness.
<i>Frame material:</i>	[Text] frame material (e.g. aluminum, wood).
<i>Frame depth:</i>	[Length] depth of the frame.
<i>Glass type:</i>	[Text] type of glass (e.g. single, double, triple).
<i>Shading elements:</i>	[Text] type of shading (e.g. shutters, awnings).
<i>Depth from the wall:</i>	[Length] depth from the wall's inside surface.
<i>Height:</i>	[Length] height from the ground.

Fire

<i>Fire rating:</i>	[Text] fire resistance of the elements (e.g. for walls, floors, columns, doors)
<i>Emergency:</i>	[Yes/No] identification of the elements with emergency function (e.g. lighting, doors, stairs).

Link

<i>Technical product sheet:</i>	[URL] link to manufacturer technical product sheet.
<i>CMMS:</i>	[URL] link to CMMS platform.
<i>O&M manual:</i>	[URL] link to O&M manual.
<i>Maintenance procedures:</i>	[URL] link to maintenance procedures. UNI 11257 requirement.

Maintenance

<i>Status:</i>	[Text] maintenance level of the object.
<i>Fire check:</i>	[Yes/No] element subject to the fire checks provided by the legislation.

Chapter 5

BIM Data Usage

5.1 Building registry

Realizing an effective BIM model does not just mean to implement all the objects and their properties, but it is necessary to organize information so that it can be functional in retrieving data for facility management activities. Data acquisition and survey as well as three-dimensional parametric modelling activities, previously described are just the first steps for an intelligent building management process setting. BIM model systematically stores different type of data according to the various disciplines, which can be updated and implemented over time. Despite the fact that the parametric model is a database in itself, consulting it may not be immediate, especially for people who are not expert in using the software. For this reason, the use of schedules and themed plan views is exploited for an overall knowledge of building, promoting immediate use by the Facility Manager/Department. Schedules in Revit are considered a very useful instrument for optimizing the architectural modelling phase, as well as a fundamental tool for controlling the digital model in the perspective of interoperability and data integration. They are model views in tabular display form that contain data extracted from the properties of the elements in a project. They can list every instance of the type of element that is being scheduled, as well as collapse multiple instances onto a single row, based on the schedule's grouping criteria (Autodesk Knowledge Network, 2017). The utilization of schedules allows us to list rooms for spaces management, building components for refurbishment or energy efficiency evaluation and assets for maintenance activities. By an appropriate use of shared parameters and equations within schedules, it is possible to make the most of their format for each different purpose, from analysis to managing or reporting. In addition, these exhaustive inventories are automatically

updated as the model suffers changes, so a univocal relation between the extracted information and the effective elements present in the model is guaranteed. In the case of As is model, schedules have been applied to the primary building components (e.g. walls, floors, windows or roofs), electrical and HVAC fixtures and conceptual items which spatially describe the building (i.e. rooms, areas and masses). While in an As built model, schedules provide a comprehensive representation of all the building components, making explicit their spatial and functional relationships. Therefore, BIM objects and their properties organized in a structured way through schedules contribute to the definition of the building registry including also drawings to identify the location of the elements quickly.

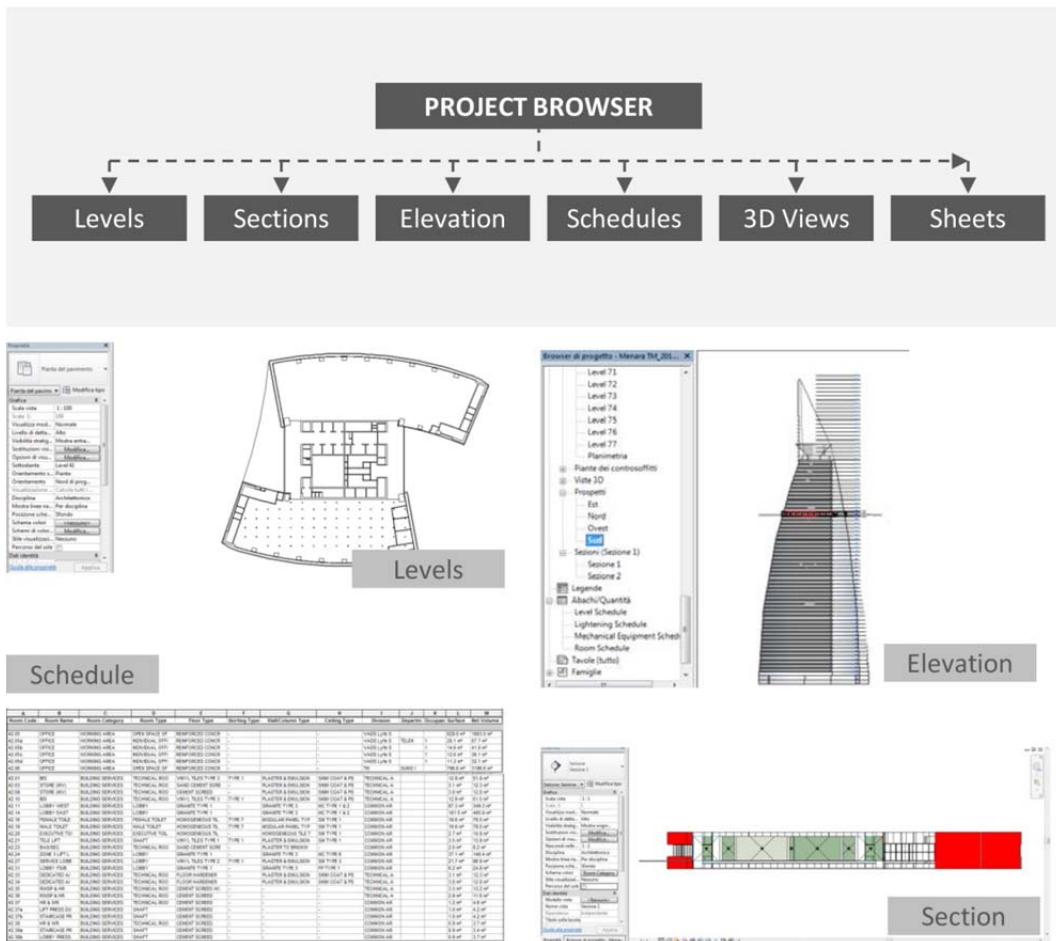

Figure 39: Building registry.
Case study: Menara TM, Kuala Lumpur.

Creating a single database for the building can give value to Real Estate services as it includes information that can be exchanged between the different actors and applications during the building lifecycle. Sharing, integrating, tracking, and maintaining a coherent Building Information Model will affect all processes and participants that interact with that data (Teicholz, 2013; Eastman, Teicholz, Sacks, & Liston, 2011). In this sense, BIM aims to change the relational procedures between the parties involved and transforms the existing conflicting patterns in collaborative models. Hence, the digital model is not a simple drawing but it becomes the starting point for a multitude of possible representations. The potential expressed by the database resides in the fact that it can be fully queried, so as data can be directly used and exported to other formats, or integrated with other systems, optimizing the process.

As it is possible to see by the image below, BIM data intercepts most of the needs of facility management services, as defined by the Appendix B of the UNI EN 15221-1:2007 (UNI & CEN, UNI EN 15221-1:2007, 2007). The parametric model contains information related to spaces utilization and set up (spaces services), people and their activities (employee services), building optimization and maintenance processes (building services), extending the meaning of BIM to management methodology able to provide smart services.

The understanding of the challenges affecting BIM for FM application is crucial at this stage moving from a traditional approach to Facility Management 4.0 based on the use of technology and innovation.

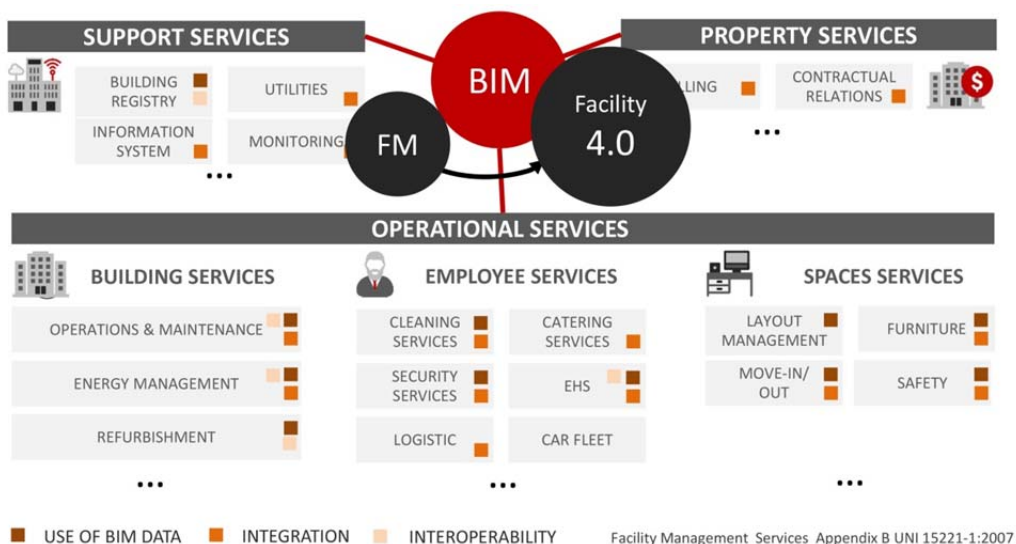

Figure 41: Facility 4.0 Smart services.

The relationship between the model and these services can take place (i) through direct use of data and functionality setting in the modelling environment (e.g. space management, fire asset), (ii) by exporting data to other formats through interoperability to perform simulations with specialized software (e.g. energy, CFD) (iii) through the integration of data with other data sources (e.g. CAFM, CMMS). Only with this approach the BIM model can provide an added value for the management process taking advantages of the parametric software potentialities. In this way, the benefits of using BIM for FM can be better understood for managers enabling a revolution for the entire building process.

In order to connect the database obtained from the BIM model with other datasets, it can be exported through Open Database Connectivity (ODBC) database using the *Revit DBLink* plug-in. As mentioned in the previous chapter, all data can be extracted in the table according to the objects, including shared parameters. This allows us to use them in any other systems improving data concerning buildings. For example, data about rooms, occupancy and envelope characteristics of public buildings can be matched with other energy consumption and systems database of the city to improve the energy performance analysis at building, district or city level. However, Revit data structure is very complex, so it is necessary to understand the relationship among entities in order to find the same information that can be organized with a schedule. For example, several tables (e.g. window, window type, host, wall, room, level, material) are needed to describe a certain type of window, of a certain material, placed in the wall of a room.

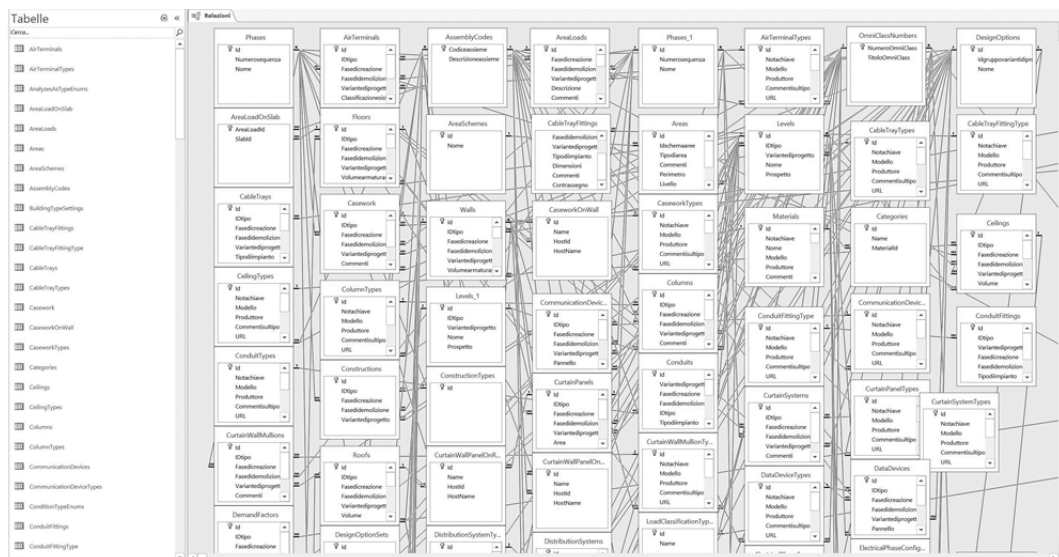

Figure 42: Access Revit database.

5.2 Space Management

Spaces represent the key element for facility management activities and services, as stated in the previous chapter. However, this aspect is often underestimated, both in design and management phases, greatly limiting the ability to carry out analysis on the building. An accurate knowledge of the space, provided by the combination of the spatial and geometric information provided by the 3D model with management data, gives the possibility to Facility and Building Manager to improve processes.

A BIM model cannot be considered functional for Facility Management if spaces are not mapped appropriately.

This operation needs to be carefully planned because it strongly affects the data returned automatically by the modeling software such as surfaces and volumes. Through the Revit *Room*, in fact, different modes for delimiting spaces are allowed. For management purposes, the most meaningful representation is constituted by net surfaces/volumes, which are used, for example, for the verification of square meters occupied by employees or for the calculation of the surfaces to be cleaned. With regard to the internal/external gross area or other type of surfaces (e.g. commercial) it is possible to use the *Area* function to obtain aggregate areas data including walls. All rooms must be individually identified to get more and more detailed information. In addition, different functions within the same space must be mapped. For multi-level environments such as shafts, lifts, stairs, it can be convenient to create more rooms at individual levels. This arrangement allows subdividing the overall dimensions of these spaces, per level, obtaining a complete view of the floor surface allocation among the different categories of space use. The logic of using the plan as a reference also matches very well with CAFM systems, towards which integration is possible, as illustrated below. The vertical development of these spaces can, however, be recognized by assigning to them the same code in the *Group* parameter, for example grouping all the rooms of the same stairs placed on different levels by identifying them through the “Stairway A” supplementary information. The same principle can also be applied to group rooms belonging to the same function, such as a toilet inside the toilet block.

As anticipated in the BIM model set up section (see Chapter 4), additional parameters are required to characterize the environments, besides representing them correctly both in plan and in section. As BIM can play a big role in space management, rooms must include all the information needed to ensure a great operational control in terms of use, occupancy, and maintenance of the building. Enriching the database with the previously described shared parameters (name, category, type, division, department, capacity, occupants, average height, vault, pitched roof, accessible, open to public, compartment, heated, conditioned, extension, floating floor, false ceiling, asbestos, confined space, risk, water points,

gas points, electrical meter, gas meter, water meter) allows crossing the information in an increasingly thoroughness. The parameters are organized in tabular form through the *Room schedule*, together with levels specification and area calculations, but can also be visualized through dynamic themed floor plans. This functionality is crucial for space management and greatly facilitates consultation and use of BIM data, providing effective and intuitive support for highlighting the distribution of a parameter in the different floors of a building. The most useful views to set through the *Color scheme* include the intended use and occupancy of the spaces. Such approach is effective for all types of FM BIM models, as there is no significant difference in space mapping procedure according to different building type or their use.

In order to allow the Facility Manager to carry out performance analysis on spaces it is necessary to objectively define surfaces, by **adopting international standards**, such as BOMA (Building Owners and Managers Association, 2010). This methods of measurement is for offices, but it has also been applied to other types of buildings (e.g. schools, public spaces) within this study. Applying a common master data model, tailoring it according to specific cases, allow us to compare data among different buildings within the same Real Estate, such as for the public heritage. Thanks to the subdivision of spaces in functional areas (i.e. working area, support area, building services, auxiliary area, vertical connections, external area), it is possible to obtain some useful indicators, like the Efficiency Index, which describe the best exploitation of a rented area. It is calculated by the percentage ratio between the Net Usable Area (NUA) and the Net Lettable Area (NLA). The benchmark value is 75%. However, if the existing heritage is the object of the analysis, it is convenient to activate space optimization processes up to 50%. Since every room type corresponds to a well-defined room category, as reported in the following table, a *Key schedule* has been implemented to speed up and control data entry.

Space needs and space usage are usually dynamically based on the ever changing needs of the organizations. It is therefore essential to map the organizational units/tenant who occupies the spaces. The articulation may have multiple levels (e.g. division and department) depending on the organization. For example, the same organizational structure of the municipality of Turin has been adopted for the public buildings of the city, which provides for a distinction in three levels: *Direction, Management Area, Service*. Space governance is essential when multiple organizations occupy the same building/floor, allowing us to identify the room as a cost center. This means that **space chargebacks** allow **cost** chargebacks in several contexts such as rent, energy bills, maintenance costs, cleaning.

Space occupation is also defined by the number of people occupying the spaces and their maximum crowding established by the legislation. Through these parameters it is possible to set up the **occupancy plan** of the building by the use of colored filters and labels in themed plans. In this way, it is easy to locate

workstations that are still available in a room or highlight overcrowded areas at a glance. In addition, it can be useful to map the areas open to the public (e.g. public counters, meeting rooms) in order to ensure a proper service level.

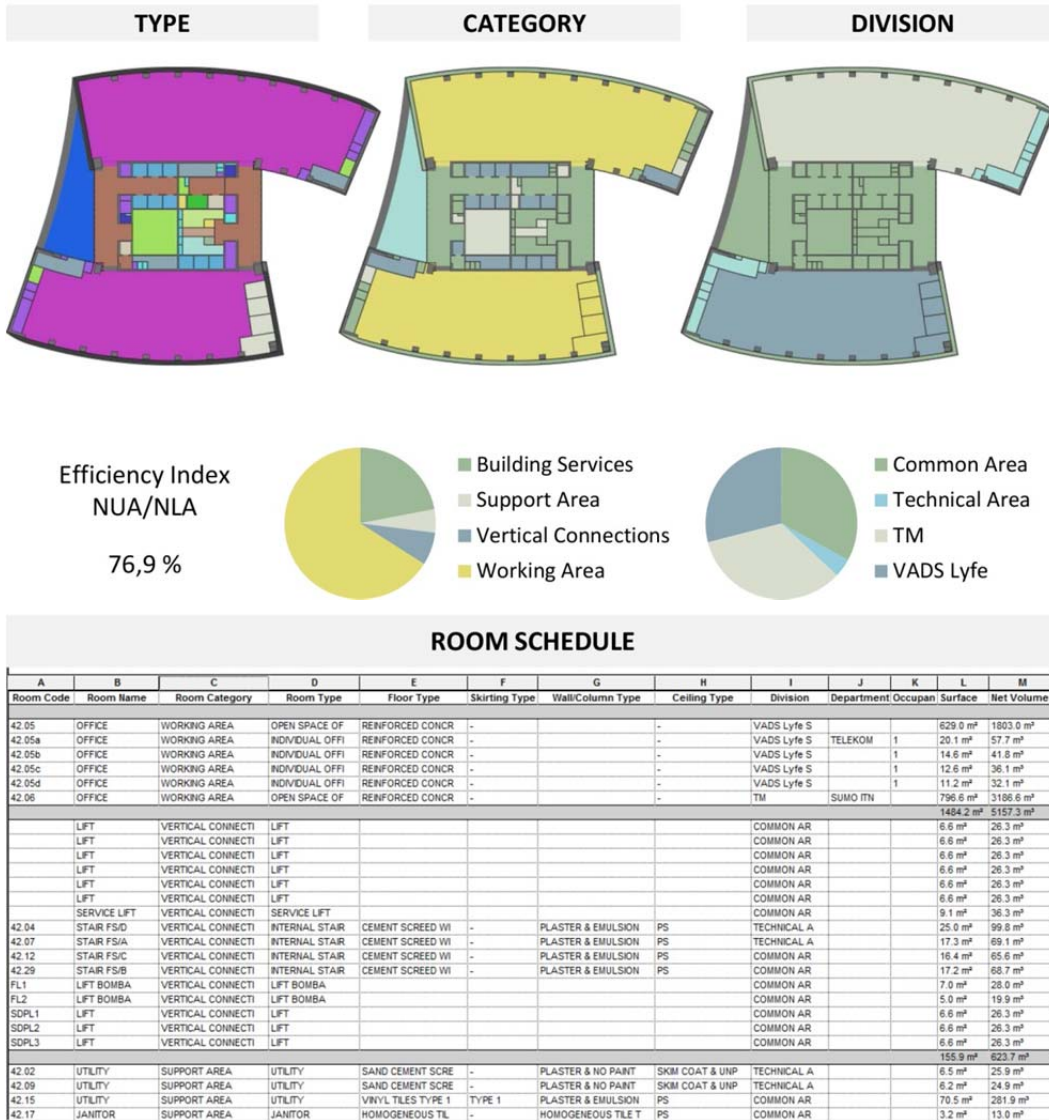

Figure 43: Space chargeback.
Case study: Menara TM, Kuala Lumpur.

Table 8: Room category and type.

Surface Type				CATEGORY	TYPE	
GIA	NLA	NIA	NUA	NPA	WORKING AREA	Office
						Open space
Classroom						
Laboratory						
					SUPPORT AREA	Reception
						Waiting
						Meeting room
						Support office
						Library
						Archive
						Relax
						Bouvette
						Copy print
						Phone booth
						Infirmary
					Post office	
				AUXILIARY AREA	Atrium	
					Corridor	
				SERVICES	Anti-toilet women	
					Anti-toilet men	
					Anti-toilet disabled	
					Toilet women	
					Toilet men	
					Toilet disabled	
					Dressing room	
					Technical room	
				Storage room		
				VERTICAL CONNECTIONS	Indoor stairs	
					Outdoor stairs	
					Ramp	
					Lift	
					Elevator	
				OUTDOOR AREA	Shaft	
					Balcony	
					Terrace	
					Car park	
					Bike park	
					Green area	
					Courtyard	

Through a BIM model it is possible to obtain several **facility management** and key performance **indicators** (KPIs) useful for evaluating the utilization rate of the space and occupancy as well as performance measurement of the maintenance activities (Ugliotti, Utilizzi del modello BIM per il FM, 2017). The accurate and structured inventory of the building elements allows to relate information about spaces and relative intended use with the facilities costs and the energy consumption. In this way, KPIs can support the correct chargeback of costs on the basis of cost centre or responsibility.

Quantitative indicators and performance measurement

% NFA from GFA

% NLA / NUA

NLA zone or building

% Utilization rate of spaces

NFA / Room Category or Room Type

NFA/ 1 working place or per 1 user / 1 tenant

% Occupancy rate NFA

Occupants / Floor or per working area

Equipments / room or level

Assets/ room or level

Opaque surface/ Transparent surface

% Heated or Conditioned NFA m² from GFA m²

% Heated or Conditioned NFA m³ from GFA m³

Heated or Conditioned NFA m² / floor or 1 tenant

Heated or Conditioned NFA m³ / floor or 1 tenant

Costs indicators

€ Gross FM Costs (TCO) / 1 m² GFA, annually

€ Operational Consumption Costs / 1 m² of GFA or per 1 user/1 tenant

€ Cleaning Costs / 1 m² of GFA

€ Utilities Consumption Costs / 1 m² of GFA or per 1 user/1 tenant

Electric energy consumption kWh / 1 m² of GFA or per 1 user/1 tenant

In addition to keeping track of the current state, the facility manager plans upcoming moves and future what-if scenarios. With BIM, several **layout simulations** can be set in order to verify, for example, if a different distribution of the working area can provide additional workstations, improving the efficiency of the building, or if it is necessary to search other solutions. In particular, it can be noticed that the percentage of spaces used as building services significantly influences the efficiency of the asset, as it directly affects the usable area. Moreover, the BIM model is exploited as **validation tool** by the use of *Conditional Instruction* to check for example the minimum dimension of toilets or the minimum dimension for windows to guarantee the amount of sunlight provided by law requirements.

Once the use of spaces has been established, all the facility services must be set up using **BIM floor plans and rooms as master data**. In this way, all the facility processes can use coherent data and take advantage of the associated information without having to search for it from time to time. For example, the cleaning service is closely related to the intended use and the occupancy of the spaces as well as the presence of the public. Keeping the spatial system up-to-date allows you to speed up the attribution of cleaning procedures and their service levels to the rooms. Moreover, by introducing a cost parameter (e.g. €/m²/month), it is possible to automatically derive the spending scenario by setting a calculated value (e.g. €/month) in the schedules. Data can be crossed by building, levels, as well as organizations or usage. As a database, the system updating according to modifications enables a better control and optimization of services.

Furthermore, it is also possible to use the BIM model for **event management**. In the case of areas used for events (i.e. meeting rooms, arena), different configuration of the space layout can be handled by attributing visibility parameters to the objects. In this way, only the outfitting corresponding on a specific layout can be displayed and its available number of seats can be automatically calculated. In the Pala Alpitour case study, for example, four different configurations of the arena have been set up.

Despite the many applications, BIM data can be just part of the management system, especially for large Real Estate and complex buildings. In the case of information managed by other information platforms (e.g. human resources, IT equipment, tenants) it makes more sense to link the BIM model into this systems, such as CAFM, establishing an integrated environment, as explained in the next section.

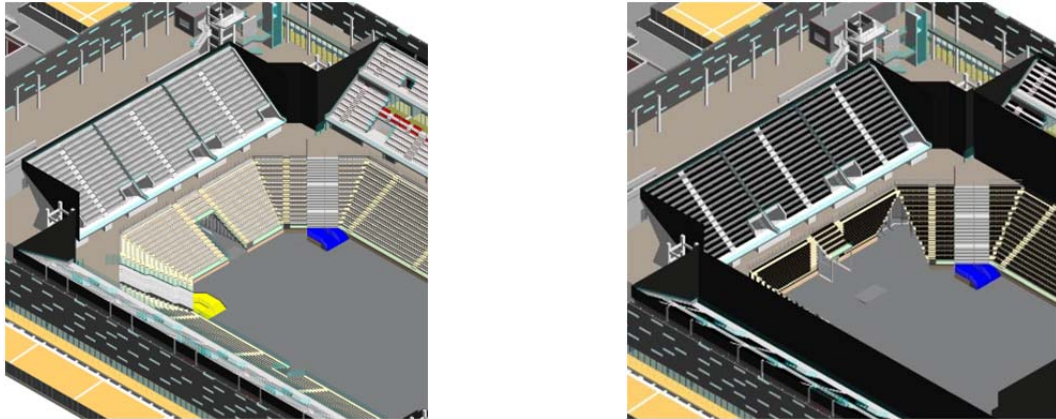

Figure 44: Configuration scenarios evaluation through the BIM model.

Settore DD105						
Seduta Reclinabile: Seduta Reclinabile_Aperta	7-Attrezzatura interna	7_2-Blocco servizi	7_2_1-Attrezzatura finalizzata al pubblico spettacolo	Seduta	Sedile con schienale ribaltabile	450
Settore DD106						
Seduta Reclinabile: Seduta Reclinabile_Aperta	7-Attrezzatura interna	7_2-Blocco servizi	7_2_1-Attrezzatura finalizzata al pubblico spettacolo	Seduta	Sedile con schienale ribaltabile	410
Settore DD107						
Seduta Reclinabile: Seduta Reclinabile_Aperta	7-Attrezzatura interna	7_2-Blocco servizi	7_2_1-Attrezzatura finalizzata al pubblico spettacolo	Seduta	Sedile con schienale ribaltabile	450
Settore DD108						
Seduta Reclinabile: Seduta Reclinabile_Aperta	7-Attrezzatura interna	7_2-Blocco servizi	7_2_1-Attrezzatura finalizzata al pubblico spettacolo	Seduta	Sedile con schienale ribaltabile	121
Settore DD204						
Seduta: Seduta	7-Attrezzatura interna	7_2-Blocco servizi	7_2_1-Attrezzatura finalizzata al pubblico spettacolo	Seduta	Sedile con schienale fisso	424
Settore DD205						
Seduta: Seduta	7-Attrezzatura interna	7_2-Blocco servizi	7_2_1-Attrezzatura finalizzata al pubblico spettacolo	Seduta	Sedile con schienale fisso	368
Settore DD206						
Seduta: Seduta	7-Attrezzatura interna	7_2-Blocco servizi	7_2_1-Attrezzatura finalizzata al pubblico spettacolo	Seduta	Sedile con schienale fisso	326
Settore DD207						
Seduta: Seduta	7-Attrezzatura interna	7_2-Blocco servizi	7_2_1-Attrezzatura finalizzata al pubblico spettacolo	Seduta	Sedile con schienale fisso	368
Settore DD208						
Seduta: Seduta	7-Attrezzatura interna	7_2-Blocco servizi	7_2_1-Attrezzatura finalizzata al pubblico spettacolo	Seduta	Sedile con schienale fisso	424
Totale generale: 9309						

Figure 45: Configuration scenarios management.



Figure 46: Space management through the BIM model.
Case study: Pala Alpitour, Turin.

5.3 CAFM integration

In order to make the digitalization process effective, the building documentation needs to be available for consultation by all the offices involved in asset management as well as by the occupants themselves. For this reason, the integration between BIM software and advanced management platforms – like Revit and Archibus – has been tested, investigating the potential of the BIM database. Archibus is a worldwide known Computer Aided Facility for Real Estate. It allows us to get an overview of a Real Estate portfolio as well as to obtain specific information about a given asset in terms of its typology, occupancy and maintenance procedures. BIM is today one of the major innovations in the field of facility management, allowing to overcome the limitations already existing in traditional CAFM systems such as lack of data consistency between individual floor plans, incorrect match between assets and rooms and between maintenance plan and asset. Hence, the link between parametric models and the management platform is considered a strong point within the process in order to have a better control of the ordinary activities, such as *Space Inventory*, *Personnel and Occupancy*, *Service Desk*, *On Demand Work* and *Preventive Maintenance*. The task of separately managing drawings and alphanumeric data is often an inefficient duplication of effort (Archibus, 2008), particularly in relation to the inevitable updates and changes that can occur on a daily basis. The use of parametric models pursues the goal of replacing and enhancing the traditional CAD graphic interface. As a result of the tests performed, it is possible to affirm that great opportunities are allowed through the database-database interaction, significantly improving the data exchange process. The connection is provided by the *Smart Client Extension for Revit®*, which allows us to link the building floor plans of the model and to automatically catalogue spaces and assets previously defined. In this way, the results of the design or the survey activities, can be directly used, establishing a unified environment for managing facilities, improving productivity and ensuring data accuracy.

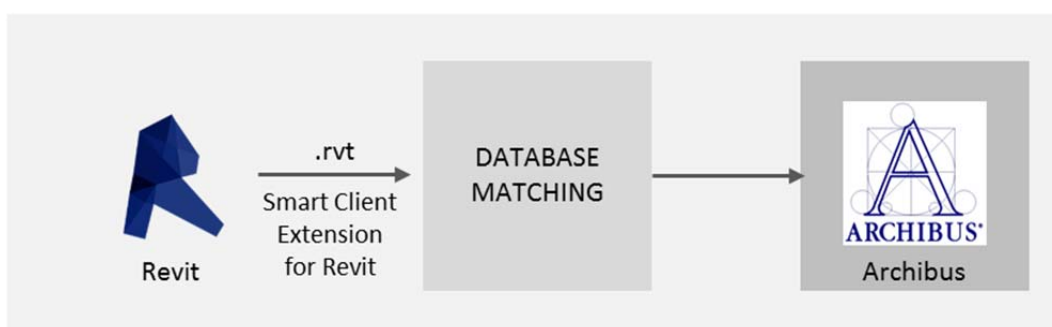

Figure 47: Revit-Archibus interoperability process for FM.

The plug-in allows us to use the Revit file in its native format without having to export it. This allows us to not lose information through software. As Revit and

Archibus are both database, it is essential to provide an accurate matching of the tables and parameters to ensure a bi-directional communication. In the correlation panel, it is possible to select the information to be linked and to fix which of the two databases is the master data for each parameter in order to keep updated and synchronized both the graphic and the informative parts during the management. Operatively, the first step for the implementation is to create the space inventory environment, which is constituted by three levels: *Building*, *Plans* and *Rooms*. Once defined the corresponding entity of the building and the different levels, it is possible to connect the rooms of the BIM model. If the link between the databases occurs during the BIM model implementation, it is possible to incorporate database-driven information from Archibus to the Revit model, such as *Room Category*, *Room Type*, *Division* and *Department*, without having to create them as shared parameters. Alternatively, the additional fields included in the BIM model can be correlated to the fields in Archibus. As regards the classification of space, Archibus adopts the BOMA method, which is perfectly consistent with the indications provided for setting the BIM model for space management described in the previous section. The automatic population of architectural drawings allows us to reduce time and effort and to immediately start operations. In the same way of rooms, other entities of the BIM model can be connected in order to manage them. The most common objects that can be connected to system populations are: mechanical equipment, lighting devices, computer equipment and fire asset. Starting from the building inventory, it is then possible to activate and manage the facility services as well as to associate data coming to other systems, such as an employee with its room/workstation. In the latest versions of the software, the model can be fully cross-examined and displayed in 3D, exceeding the limitations of two-dimensional plans. This represents a powerful instrument to maximize the BIM potentialities for management. It has been noticed that it is not necessary to introduce simplifications or special arrangements in the realization of the FM BIM model, even if the system may have difficulty in managing as built models of complex buildings and large BIM Real Estate. The tests have been carried out mainly within the TOBIM project (Osello & Ugliotti, BIM: verso Il catasto del futuro. Conoscere, digitalizzare, condividere. Il caso studio della Città di Torino, 2017), where one of the main goals has been to integrate data from different platforms to enhance knowledge and management activities for the Turin public buildings. In the digitalization process initiated by the public administration, the BIM models resulting from the survey activities can be implemented from time to time in Archibus, enabling a cross query of data among different buildings, sites, organizations. Therefore, several analysis and reports, designed from a facility manager's perspective, can be processed for building lifecycle management. In this way, possible optimization and refurbishment strategies can be evaluated to stimulate the city renewal starting from Facility Management performances. The advantage of connecting the BIM model to a CAFM platform lies in the fact that a greater number of people can access data in a simplified manner through a web portal. This allows all the organizations involved in building management to

consult and accordingly use the same data (e.g. floorplans, areas, intended use, equipment) for setting up facility management services according to specific needs. For this reason, to keep operating the system, a constant and bi-directional updating becomes essential. This means that if the building real spaces are modified, the management tool should contemplate those changes, as the same way as the 3D model updates its geometry consequently. A similar reasoning must be applied when occupancy or intended use are changed through the web portal. The continuous update of the platforms allows us to provide full commissioning information to effectively manage buildings day by day.

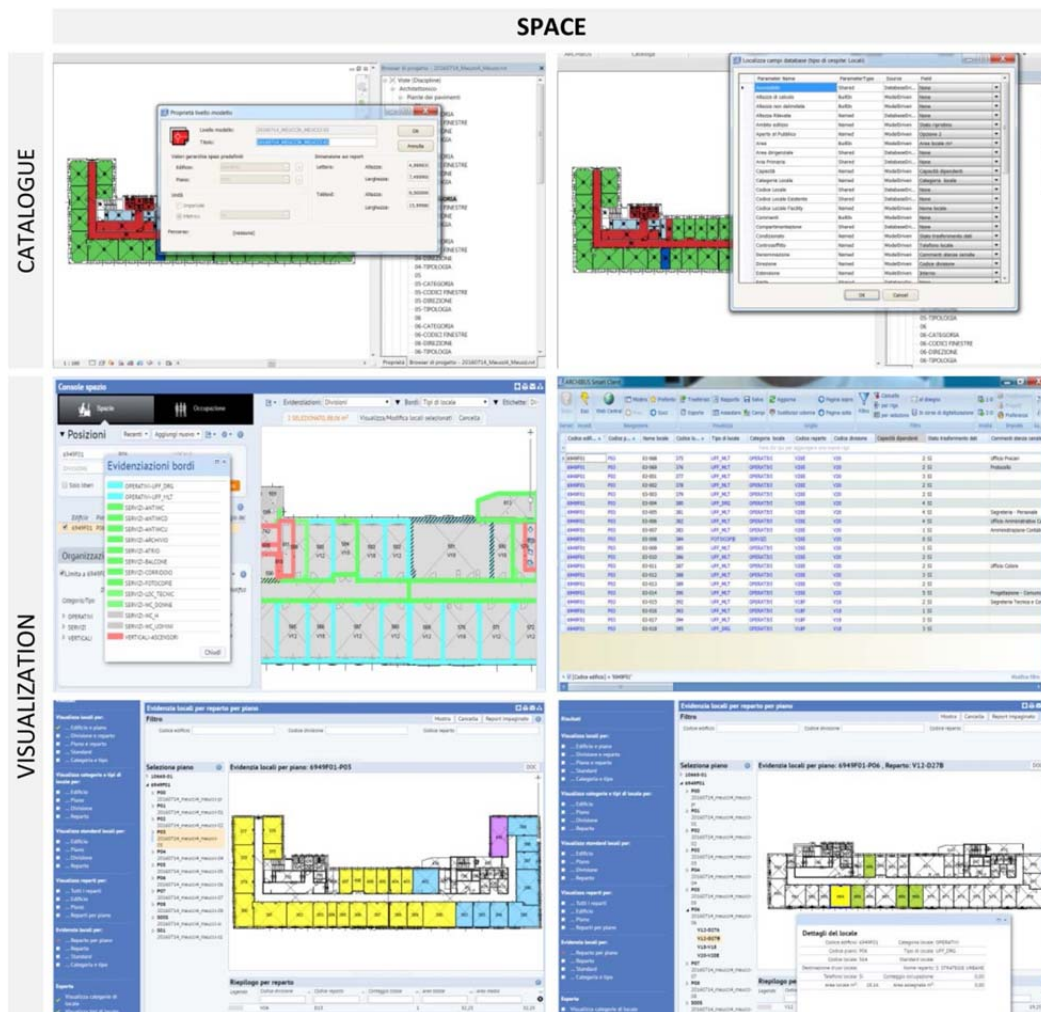

Figure 48: Space catalogue and data management.
TOBIM Project. Case study: Meucci 4 Office building,
modelled by Luciana Ricca.

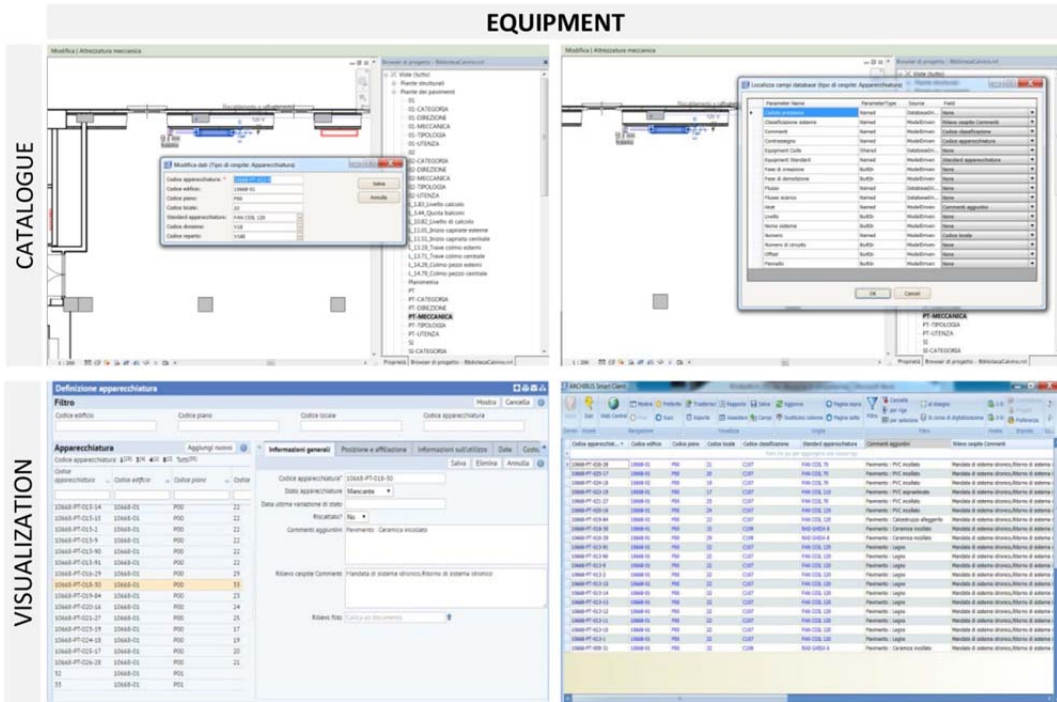

Figure 49: Equipment catalogue and data management.

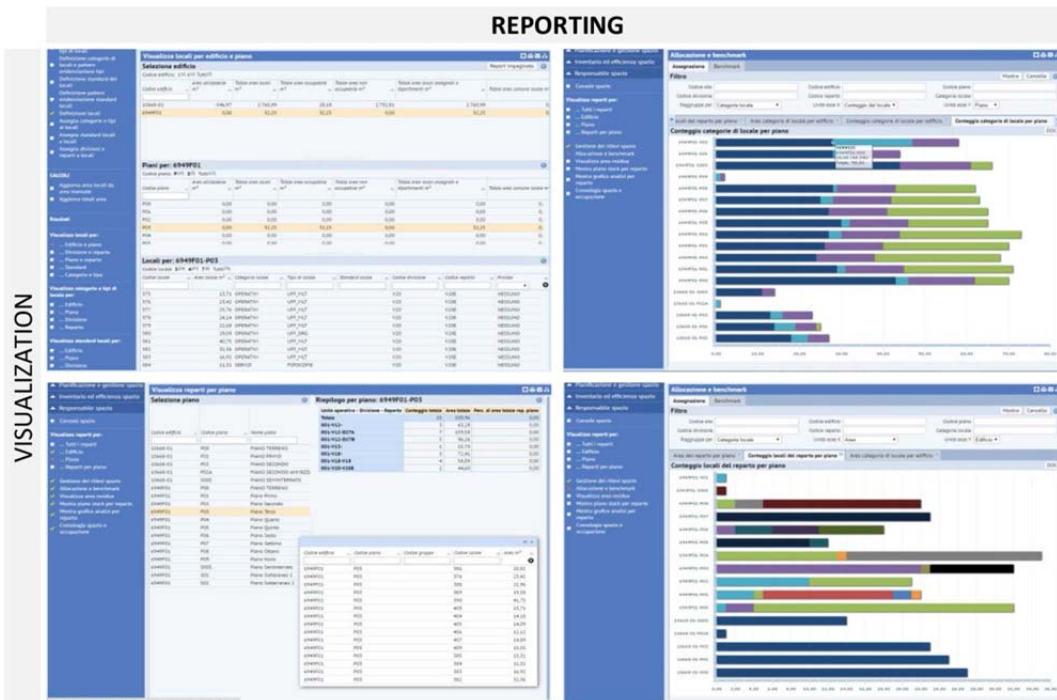

Figure 50: Space Reporting.

In order to achieve this integrated process, it is necessary to set up a dedicated **management structure** and to define an appropriate **workflow** that links all the entities that hold assets information. The Central coordination office must deal with the mutual updating of the databases, on the one hand by receiving the information provided by the technical office designers, on the other by stimulating the updating of data by the users of the spaces. It is therefore necessary to involve:

- *Central coordination office* as part of the Facility Department in charge of system management.
- *Technical office designers* that create and manage the BIM models.
- *Building Referents* who are responsible for updating data in the informative platform and for reporting to the central office inconsistencies of a single buildings.
- *Organization Referents* with competence and operation on exclusive use areas and related personnel.
- *Maintenance technicians* who use the data from systems for maintenance and return the outcomes of such activities as the system input.

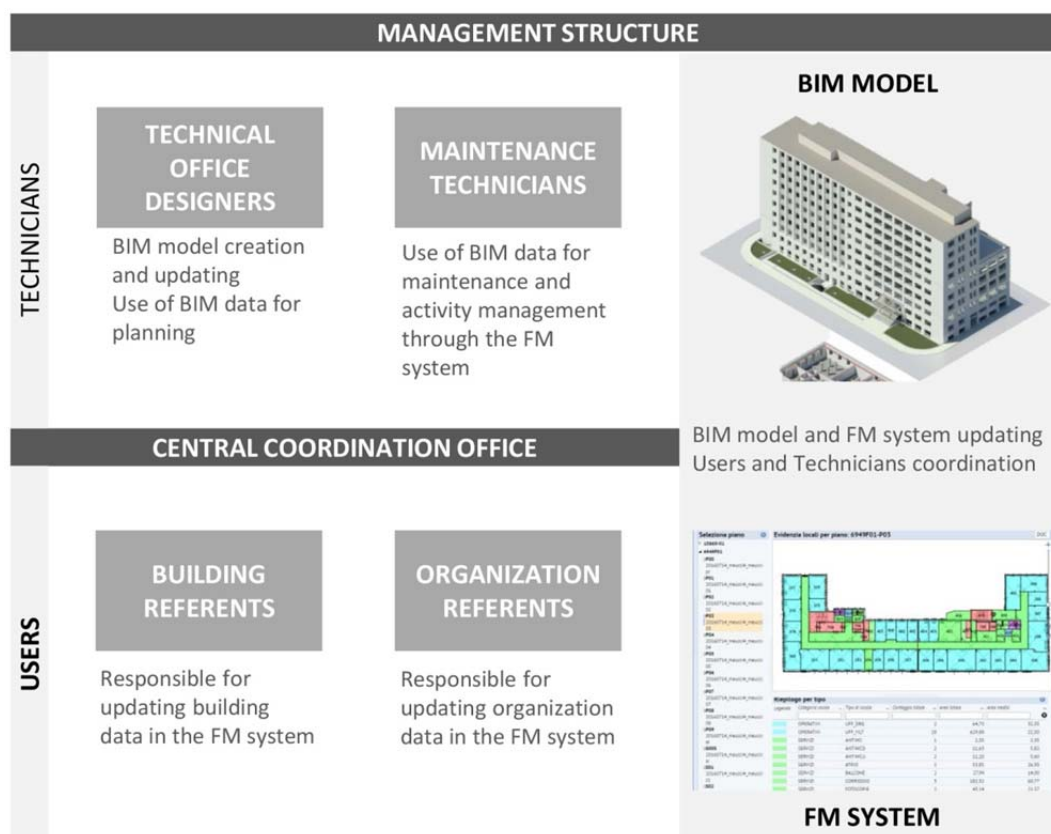

Figure 51: Management structure for BIM models updating.

5.4 Energy simulation

As the existing heritage is one of the objects of this study, it is convenient to use the BIM model also to perform simulations and energy certifications in order to promote retrofit actions. Several interoperability tests towards energy-dedicated software have been carried out with the main aim of evaluating the quality of the data exchange. The solutions explored seek to ensure the architectural model effectiveness regarding the subsequent energy elaborations. *Edilclima* and *DesignBuilder* have been selected in order to consider two different types of simulation engines within the method – stationary and dynamic model calculations, respectively. *DesignBuilder* allows us to define in detail the building characteristics and calculate the heating and cooling requirements, as well as the heat losses and the perceived comfort. Generally the structure of the software for energy simulations consists of two different features: the calculation engine and the graphic interface. *DesignBuilder* represents the best program interface for the EnergyPlus engine, which supplies two different ways for executing analysis. In the first place, it allows the tri-dimensional model of the building to be created directly by the software native tools; alternatively, it can be obtained from a BIM model either through a .gbXML exportation or by means of a specific plug-in for Revit. On the other hand, the continuous and punctual updating of *Edilclima* according to the Italian legislation, in addition to its suitability in the area of energy certifications, represents one of the main reasons for choosing it.

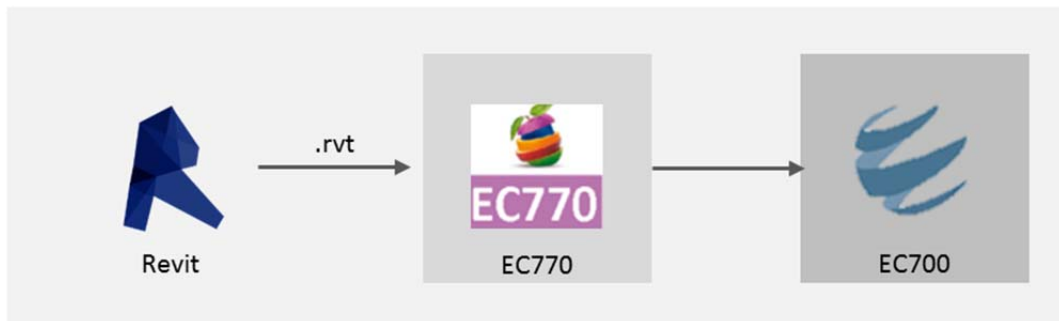

Figure 52: Revit-Edilclima interoperability process for energy certification.

The correct functioning of the *EC770 Integrated Technical Design for Revit* module has been investigated to test interoperability between software and to overcome the traditional approach on energy calculations. This plug-in allows the Revit parametric model to be exported in *EC700* to evaluate the energy performance of buildings and execute thermal calculations. The program also provides the suitable output to carry out energy certifications. Nowadays the energy certification activities are carried out according to a traditional approach by manually imputing all the needed information to describe a building and by re-designing its geometry for every plant view. This procedure implies a

considerable amount of time, especially when applied to a large heritage, and improves the probability of making errors. These difficulties can be overcome thanks to the BIM methodology, optimizing the process and making it effectively integrated. In the ideal case, the geometry and envelope characteristics of the building can be extracted directly from the 3D models and introduced in EC700 to evaluate the energy performance and execute thermal calculations, getting time savings and reducing input mistakes.

Nevertheless, the interoperability tests which have been carried out show that not all of the information set into the model is maintained within the exportation, particularly the one regarding transparent components. It is necessary to admit that a total exchange cannot be reached with the current level of software development; so a range of solutions has been developed in order to improve the process, speeding up the data input phase. These considerations, including modelling guidelines, shared parameters and customized families, have been developed from EEB project activities, aimed at correlating energy data with BIM and GIS models.

Modelling guidelines

Several setting guidelines have been established for a correct modelling to reduce errors in the interoperability process. It has been considered particularly important to pay attention to the following aspects.

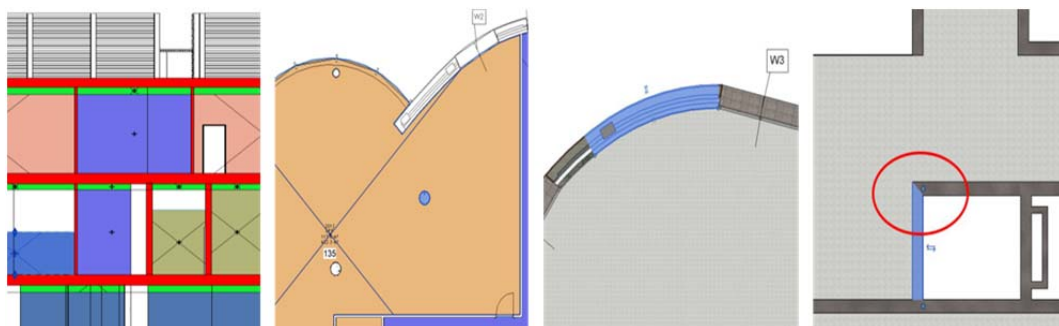

Figure 53: Example of modelling guidelines.

(i) The room entities need to represent all the building volumes considered in calculations, including the ones that are delimited by ceilings or floating floors. They have to be placed from the slab extrados to the ceiling intrados levels whereas the delimits local option must be disabled for columns in order to ensure a correct evaluation of the heated volume. (ii) The wall joints must be configured as *miter* for a correct recognition, instead of the *butt* joint type which is defined by default in Revit. In addition, walls must be properly oriented regarding their stratigraphy. (iii) The balconies or external components can be overlooked for the purpose of the energy simulation as regards their architectural representation, but must be converted into objects that generate shade into the building as their shading impact is indeed relevant.

Most of the interoperability problems affect any kind of building model, while some specific ones are related to the historical buildings portfolio due to their particular construction typology. For instance, thermal simulations are based on one-dimensional heat transfers, so they cannot consider curved surfaces – like walls, slabs or ceilings –, which must to be approximated with a finite number of flat surfaces (Ugliotti, Dellosta, & Osello, BIM-based energy analysis using Edilclima EC770 plugin. Case study: Archimede Library, EEB Project., 2016; Ugliotti, Dellosta, & Osello, Exploitation of a BIM model for the built heritage digitalization., 2016).

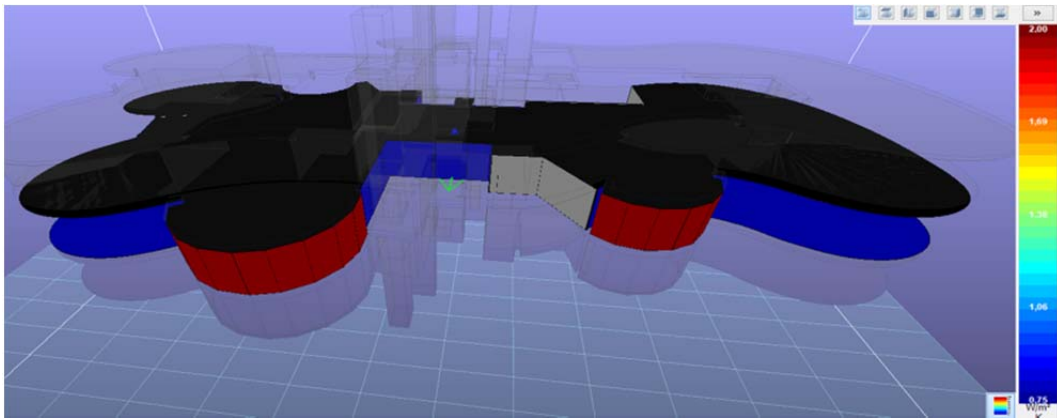

Figure 54: Visualization problems of curved walls in the EC770. EEB Project. Case study: Biblioteca Archimede, modeled by Maurizio Dellosta.

This error becomes essential for existing buildings that are characterized by vaulted ceilings. To go in depth with it, two different modelling modalities have been investigated to study their exportation into *Edilclima* and *DesignBuilder*. In the figure below both procedures and results have been collected for the barrel and mirror vault examples (respectively organised in the left and right sides of each column). The obtained results resolve that both energy software do not recognise the surface area of the vault regardless of its typology or the way it has been modelled (Tonon, 2015). To proceed with the simulation, it has been necessary to replace vaults with flat slabs able to maintain volume and surface invariables in rooms, and consequently in the entire building. This is possible by placing those slabs at an equivalent height, which can be easily recovered from the model by adding a calculated value into the room schedule. In addition, the study of historical buildings has allowed us to discover that both energy software cannot calculate U-value on walls when their thickness is bigger than 50 cm, making it difficult to carry out analysis. A similar solution can be applied to obtain coherent results from the subsequent simulations: walls thicker than 50 cm can be replaced by conceptual walls where an hypothetical stratigraphy simulates the real thermal transmittance of the wall.

<p>Modelling typology</p> <p>Interoperability software</p>	<p>In-place model</p> <p>The vaults are obtained using the "sweep" command by extruding the appropriate profile along its relative path.</p> 	<p>Adaptive family</p> <p>A mass is created using the command "Create Form" by selecting the profile of the vault. The path is defined by four adaptive points. The vault's surfaces are generated by the command "roof from surface" within the</p> 
<p>Edilclima</p>	<p>Analyzed room surface area:</p> <ul style="list-style-type: none"> -External bearing walls -Base floor and top floor  <p>The vault's surface is absent</p>	<p>Analyzed room surface area:</p> <ul style="list-style-type: none"> -External bearing walls -Base floor and top floor  <p>The vault's surface is partially not recognized</p>
<p>Design Builder</p>	<p>Analyzed room surface area:</p> <ul style="list-style-type: none"> -External bearing walls -Base floor and top floor  <p>The vault's surface is absent</p>	<p>Analyzed room surface area:</p> <ul style="list-style-type: none"> -External bearing walls -Base floor and top floor  <p>The vault's surface is recognized as a fragmented geometry, so it cannot be used for energy analysis</p>

Figure 55: Interoperability results for the representation of vaults.
Tests made by Daniele Tonon. TOBIM Project. Case study: Piazza Palazzo di Città 7.

Several obstacles have been also found in the interoperability phase regarding walls or slabs stratigraphy. Although *DesignBuilder* engine should be able to recognise materials and their relative thermal attributes within the exportation, the tests show that this procedure is not homogeneous throughout all the attempts. This criticality becomes rougher for the *Edilclima* case, as the software does not

even include the option for their recognition. This means that materials have to be re-associated to elements afterwards, which implicates a considerable workload and slows down the process potentialities. Another relevant aspect to take into account for the energy analysis is the building thermal distribution, which can be previously introduced in the modelling phase through a specific Revit tool. Nevertheless, this attribute is lost among a direct transition so the models have been adapted to make them useful regarding heating and cooling load calculations. The room schedule has been crossed with an additional shared parameter that specifies the relative thermal zone; so in this way the building information can be stored in relation to thermal performance.

Shared parameters exploitation

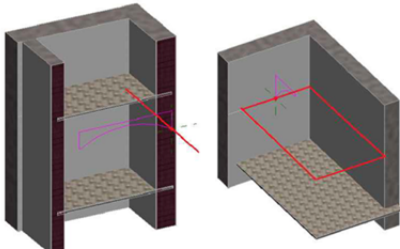
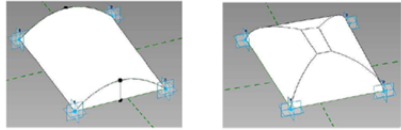
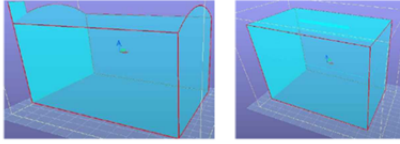
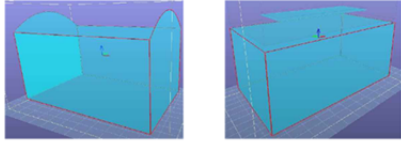
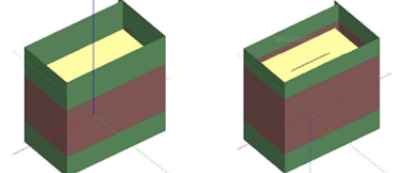
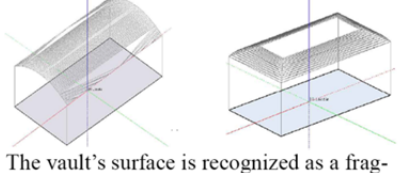
As introduced, several groups of shared parameters have been implemented into the model template for their exploitation by means of schedules. This strategy has been persuasively applied to the window elements: whereas the interoperability flow maintains the overall geometry of the building, only the maximum height and width is recognised in the case of windows whilst other detailed attributes are lost. Considering that transparent components play a key role in the building energy performance – in relation to both their geometry and materials – it becomes essential to ensure that their real shape and characteristics are considered in simulations. This objective is reached by including a set shared parameters into the window families, as previously described in the BIM model set up section, to smartly sort them in a Revit schedule for a faster input in the energy software. The mentioned group of parameters consists of the code of the window, the four external sides frame's thickness, the number and dimension of the horizontal and vertical internal partitions, the existence of shading elements (e.g. shutters), the depth of the window inside edge of the wall and its height from the ground. Through the window schedule and themed floor plans showing the code of the windows it is possible to facilitate the visualization of data and to consequently accelerate the input phase into the energy software, adding value to the process even when interoperability is not complete. However, this solution is not applicable to curtain walls as they belong to wall system families rather than to loadable ones. Unfortunately, several and unexpected problems appear in the exportation phase towards the energy software; like an incorrect recognition of glass panel dimensions. This issue is still under research with the focus on a future improvement of all relevant elements transition.

Customized families

Lastly, it is important that the energy analysis considers the shading values, which represent the percent of solar emission stopped by the external obstacles, like hills, trees, near constructions or horizontal and vertical components of the building itself. A hundred percent stands for the shadow absence, while a value of zero means the total stop of the solar emission or a total reduction of free solar

gains. The shading values are influenced by several factors that must be taken into account, including the shading elements orientation and characteristics. As regards the interoperability process, it is possible to affirm that their behaviour depends on the kind of software with which simulations are evaluated. The *DesignBuilder* engine recognises BIM components and calculates their shading impact into the building. This linear relationship does not work in the same way in the case of conceptual masses representing the external constructions: even if they are included in the model, they are not available after the exchange phase, so it is necessary to re-create them under the *DesignBuilder* environment. In the other hand, *Edilclima* is not able to obtain any of this information from the model geometry at the current level of the tool's development, so every single value must be manually calculated and inserted into the platform. Obviously, this procedure requires a great amount of resources, especially considering large Real Estate, where numerous shading values per building must be examined take advantage of parametric modelling potentialities to reduce errors and time. A specific surface-based family has been created for this purpose (Osello & Ugliotti, BIM: verso Il catasto del futuro. Conoscere, digitalizzare, condividere. Il caso studio della Città di Torino, 2017) (Barone, 2014): it is able to analyse the angular impact of overhangs and obstructions in a graphical way. The procedure can be rigorously performed by dividing the building surface into various parts with homogeneous shading characteristics and by placing the mentioned family in the appropriate position. After that, the family uses the height and the linear distance between every shading surface's gravity centre and the obstacle's surfaces to calculate the angular values. Both aspects have been introduced as instance parameters that have to be managed for every single case, as it is necessary to choose which angular value is the most appropriate one in relation to the particular barriers. The handling points present in the surface-based family must be placed in contact with the angles of the obstructions; so in this way the shading values can be deduced graphically without any other geometrical consideration. Finally, a multi-category schedule can be created to collect data from different model instances and cluster them in relation to their shading quantities. The functioning of the parametric family has been summarized in the figure below.

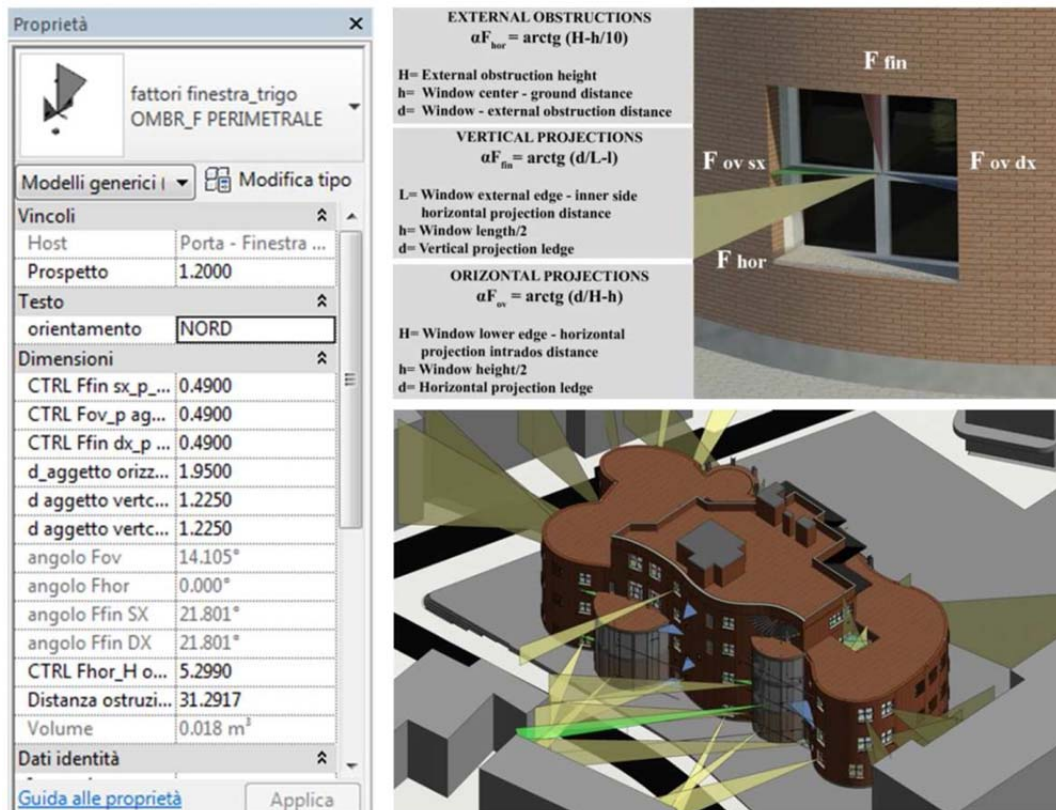

Figure 56 Surface-based Revit family for shading values calculation.
EEB Project. Case study: Biblioteca Archimede, modeled by Maurizio Dellosta.

The interoperability process for this type of investigation is still a critical issue because not all the geometric and thermal properties related to the building envelope are transferred into the energy model.

In conclusion, it is possible to affirm the fact that using a FM BIM model for energy purposes still suffers an elevate number of problematics that difficult its viability. In particular for As operate and As built model, the geometry has to be simplified and all the systems must be eliminated to make the simulation manageable. In fact, data concerning systems is currently not recognized, so it needs to be entered manually. Furthermore, it turns out to be that modifying the model implicates a rough procedure and long-time requirements; comparable with the effort needed in creating a new “energy-focused” model.

5.5 Energy modelling and monitoring

In Smart City scenario, BIM is used to analyse the existing building stock to promote a better management and retrofitting actions. As described in the previous section, the architectural BIM model can be used to generate the geometry of the energy model, minimizing misinterpretations and incorrect approximations encountered in practice (Ugliotti, Dellosta, & Osello, BIM-based energy analysis using Edilclima EC770 plugin. Case study: Archimede Library, EEB Project., 2016). Moreover, the building energy modelling and monitoring approach is one of the most challenging as it combines the knowledge of the buildings established by BIM with real data from the field collected by the Internet of Thing (IoT). These topics are the core of the EEB project that pursue a building management mainly devoted to facility and energy-managers providing near-real-time and historical information on environmental parameters of buildings and rooms, also promoting user-awareness on energy consumption, as shown in the figure below.

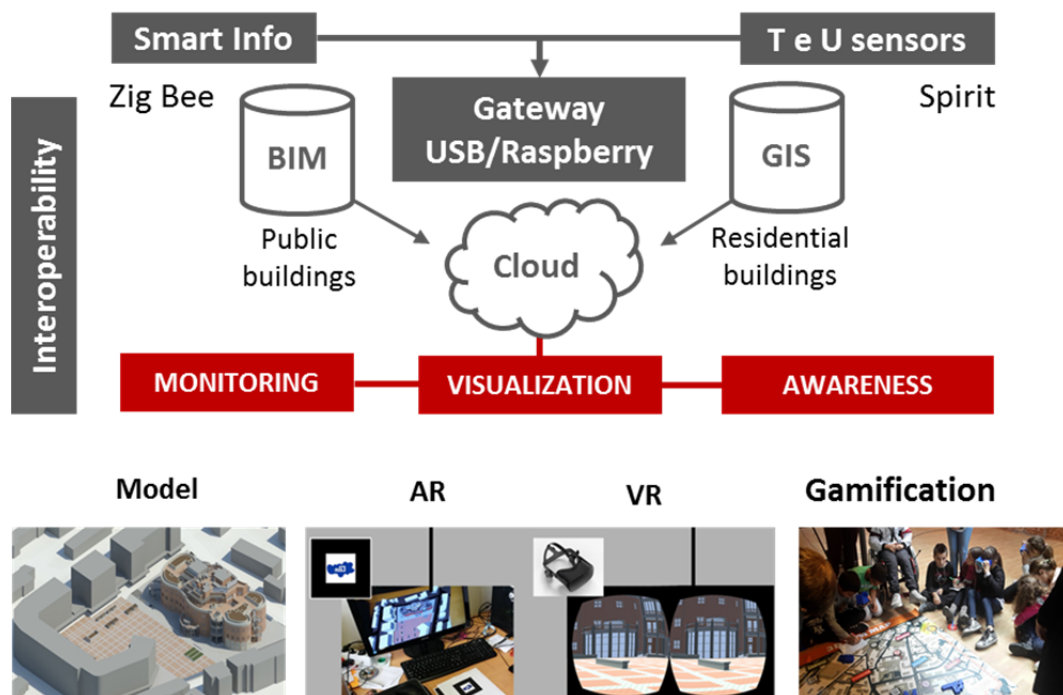

Figure 57: EEB project scheme.

The objectives is to set a common environment where different domain can exchange data according to an iterative optimization process. The EAM Simulation Engine block performs building simulations using *EnergyPlus* working with the following inputs (Bottaccioli, et al., 2017).

- Geometry and materials of building components (e.g. stratigraphy, shades) and their thermal and physical properties coming from BIM models;
- Real weather data (e.g. air dry-bulb temperature, solar radiation, average air temperature).
- Data about HVAC systems (nominal power and flow rate of radiators, nominal power and efficiency of boiler, climate control unit, on/off profile of the heating system)
- Occupancy of rooms, including number of users and time-shifts.

The outputs of the EAM Simulation Engine block are radiant, operating and indoor temperature as well as the energy consumption profiles of the building.

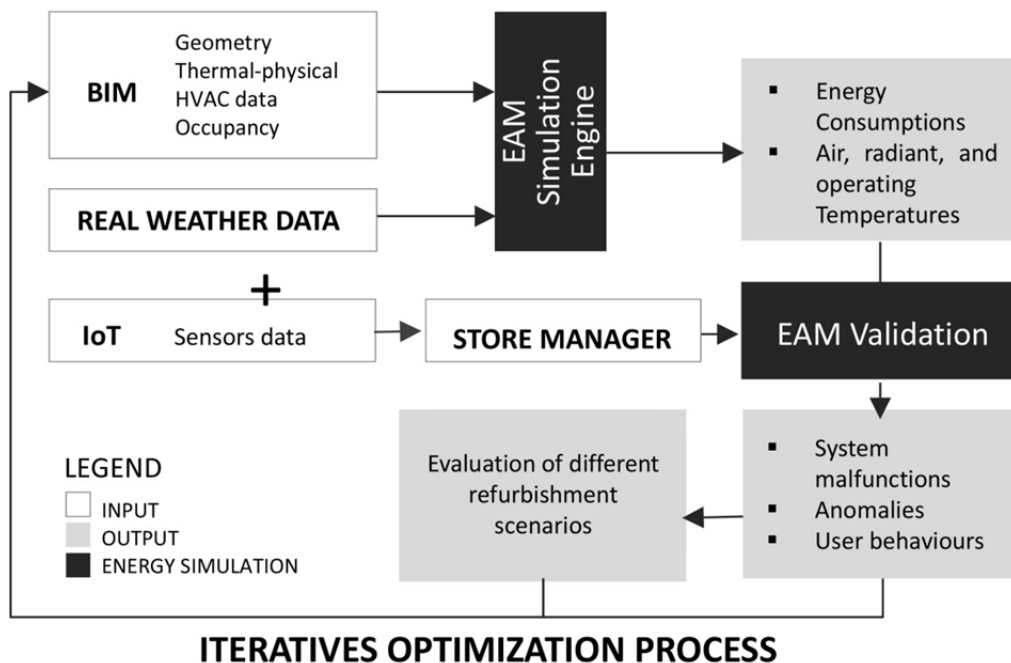

Figure 58: Proposed energy modeling optimization process.

As a strong point of these simulations, third-party weather data source from the nearest weather station (i.e. solar radiation, outdoor air temperature and humidity) has been used instead of the default Typical Meteorological Year (TMY), which is not representative of the real weather conditions. Indoor air temperature and humidity are sent every 15 minutes by IoT devices and collected in the Store Manager. Such data is needed by the EAM Validation block to validate the performed simulations, by comparing the results of the EAM Simulation Engine with the real measured values coming from the deployed IoT devices.

Analysing temperature and consumption trends, factors that may affect the energy model can be identified, such as user behaviors, malfunctions and anomalies in the system. By comparing measured and simulated data, it is possible for example to discover irregular trends of real indoor temperatures due to faults in on/off schedules of the heating system or efficiency losses of the building-system. In this context, BIM models can be used to evaluate different design and/or refurbishment scenarios (e.g. external/internal coat application, fixtures replacement and power peaks regulation), becoming the new input for the energy modelling optimization process. This process is iterative and can help building- and energy-managers in evaluating the best solution for both energy performances and Return of Investment. In addition, user-awareness is essential to minimizing insufficient energy behaviours. According to this approach, a game has been developed to explain to children the importance of energy savings, being a school the case study part of the project, as described in the next chapter.

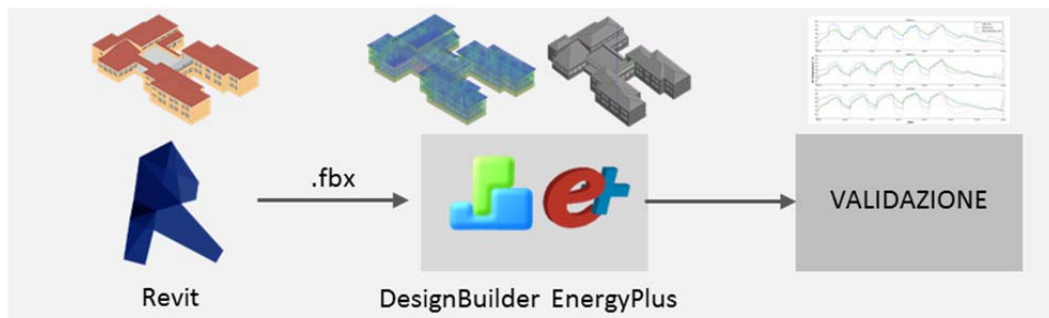

Figure 59: BIM model validation process.

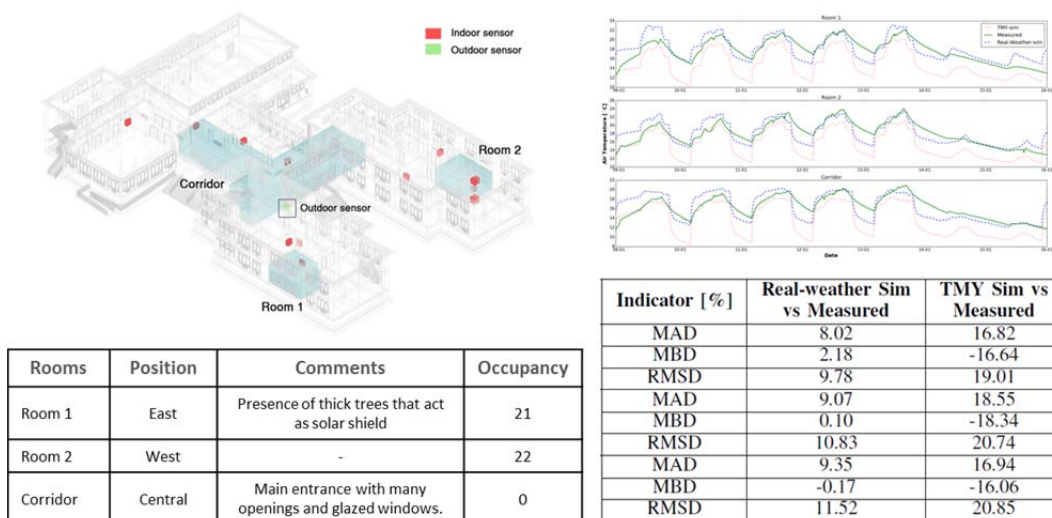

Figure 60: Simulated and measured indoor air temperature trends.
EEB Project: Case study: Rodari school, modelled by Ossama Sabbar.

5.6 Fire Engineering and Safety Management

The use of digital models and advanced methods provides significant opportunities to integrate aspects of design, authorization, construction, and management. In this scenario, the Fire Engineering and Safety Management strategies must necessarily provide for the adoption of innovative governance tools that make virtually available space information and attributes, in addition to the accident scenarios and the related compensatory measures. This need is supported by the new methodology introduced by D.M. 09.05.2007 *Direttive per l'attuazione dell'approccio ingegneristico alla sicurezza antincendio* (Ministro dell'Interno, 2007), detailed in the D.M.03.08.2015 *Nuovo Codice di Prevenzione incendi* (Ministero dell'Interno, 2015). The latter envisages a performance approach, exceeding the limits imposed by the prescriptive approach, launching a new challenge for professionals in the sector. Against this background, the exploitation of Building Information Modelling can be considered a further technical and technological development to set up a management model that integrates the Fire Engineering and Safety Management disciplines within an optimized process since the early stages of the building life cycle. The BIM model is configured as the virtual environment where specific functionalities can be developed to specify measures and parameters of the prescriptive Fire strategy. These are then operatively declined in Safety Management actions extended to both the building and the surrounding area.

BIM is rapidly changing the ways companies work together to design, build and operate projects. Individual professionals are involved in a cross-sectional process that involves the transfer of specific knowledge beyond the limits of specialized and professional services, becoming like gears that contribute to a more complex machine. The BIM database can collect and organize a large amount of information coming from the different disciplines of the construction industry. It represents the common environment in which architectural, structural, and systems data can be updated and displayed integrally in their latest version. For this reason, it is important that the fire prevention sector also becomes an integral part of this collaborative process. In fact, a more effective fire strategy can be developed starting from a digital model due to a better three-dimensional comprehension of the artefact. The powerful spatial coordination capability of BIM, also known as clash detection, is the primary way projects involving multiple trades that are taking advantage of BIM. This aspect initially is a disadvantage for those disciplines that are traditionally represented in two dimensions, such as MEP and fire prevention, as 3D BIM is more design-intensive and it requires more steps and extra work. However the effort required for the creation of parametric objects is compensated by the benefits during the building life cycle management. To support this activity there are several software or plug-in able to speed up the modelling phase of fire elements, such as sprinkler systems and fire alarm control panels, and there is a growing demand for

manufacturers to create a full range of BIM-compliant content and information about their fire protection products. From properties associated with objects, it is possible to check better the fire requirements in relation to space usage and conformation, supporting the overall strategy assessment. Furthermore, if the knowledge of the building is stored in a unified and structured way, a greater number of users – designers, maintenance technicians, end-users, responsible for safety in accordance with the provisions of D.Lgs. 81/08, fireman, armed forces – can access data efficiently according to different levels of detail.

The following describes the main considerations and applications conducted in the field of Fire Safety Management. These kind of implementations are suitable for As built model because they can support design process, but can also be used for As operate models and partially for the As is. The study has been carried out on the new UnipolSai headquarter in Milan as it provides an excellent case study to explain the benefits of the BIM method within Fire and Safety disciplines applied to high-rise complex buildings.

- **Fire Engineering cross-cutting nature affects the model management**

Fire discipline can be part of the model breakdown, through worksets or links, as it identifies a specific subject of implementation. However, only certain elements, such as extinguishing and signaling means, and escape routes can be entered into a stand-alone model. Other requirements concern building and technology components, therefore they have to be associated with elements of other disciplines (structural, architectural, finishing, MEP, rooms). For example, the fire rating is a property to be attributed to the load-bearing structures (walls, floors, pillars) and to internal partitions and doors, so as to define the horizontal and vertical compartments of the building.

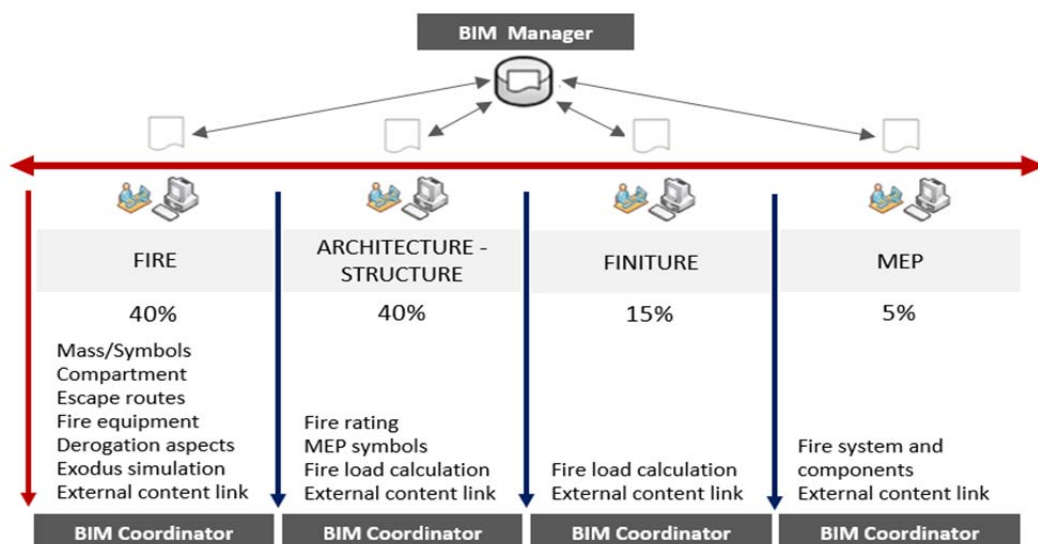

Figure 61: Transversal nature of the fire implementations.

Considering the worksharing, this represents a critical operational issue to manage as it involves different professional roles and responsibility of BIM data ownership. To enable an integrated process, the fire expert must be able to act on models of other professional responsibility. This aspect has to be carefully managed at the contractual stage and periodically verified by the BIM manager.

- **From two-dimensional symbolic representation to parametric objects**

The fire project is typically represented by two-dimensional symbols which, in line with the technical regulations of the sector, illustrate the main design strategies and solutions adopted. The traditional approach, limited to mere graphic representation, is overcome by BIM from the creation of parametric objects, which can be grouped automatically according to their typology. The introduction of parameters and the setting of ad hoc schedules of components enables a dynamic management of data over time, enriching the graphics with the information component, as described below. Thanks to Fire BIM objects, the fire designer can set functionalities for automatic checks and control of the fire strategy, supporting the validation of design and compositional choices.

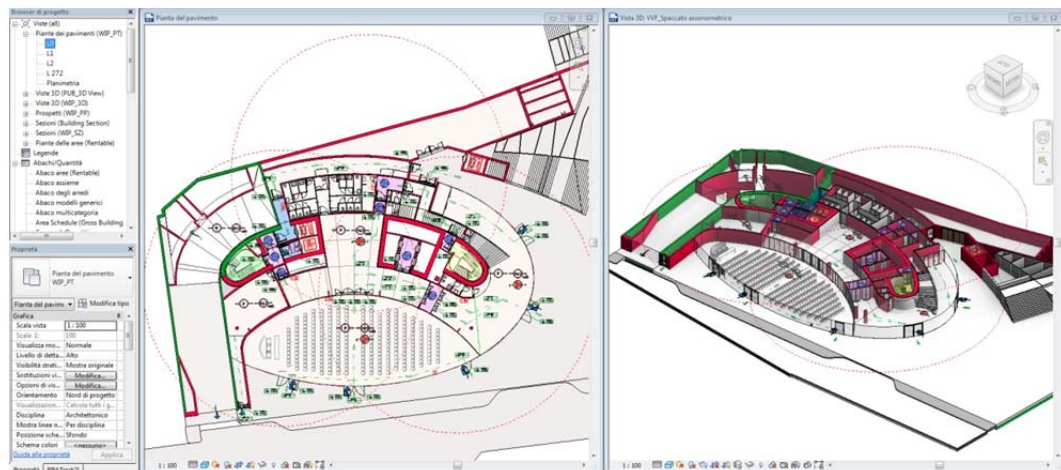

Figure 62: BIM Fire strategy implementation.
Case study: UnipolSai headquarters, Milan.

- **Implementation of information according to the process stage**

In relation to the stage of the process, the parametric objects can be characterized by a different Level of Detail/Development (LOD), both in terms of graphic representation and associated information. In this way, it is possible to gradually extend the data richness of building components, providing additional technical information as well as external links to documents or management information platforms. According to the LOD Specification (BIM Forum, 2016), the declination of the concept of LODs in the Fire Engineering field can be described and re-elaborated as follows.

Concept design phase (corresponding to LOD 200): simplified representation of the object with approximate information on location, size, quantity and type.

During this phase, the fire designer can define the overall project performance requirements and the fire resistance properties of structures, according to an iterative process that takes into account the possible architectural/structural layout updates.

Preliminary design phase (corresponding to LOD 300): representation of the main components of the element with measurable information on location, size, quantity and type. Associated data: materials, performance requirements, fire rating and functional specifications.

Project performance requirements can be easily verified, also making specialized simulations on structural elements. The results of external assessments and calculations can be included into the BIM model as links, making them promptly accessible during the later stages.

Detailed design phase (corresponding to LOD 400): detailed representation of the element components. Associated data: manufacturing and installation data, technical data sheet, operating and maintenance manual, certificate of compliance.

Project performance requirements can be easily verified according to possible variations / variants, both in terms of layouts and selected materials. Thanks to the better control of the project, it is more efficient to set up alternative construction or layout scenarios. Finally, technical specifications, certifications and acceptance of work documentation of the installed components can be collected and integrated in the model, completing the database of information used as the basis for the subsequent maintenance and emergency management phases.

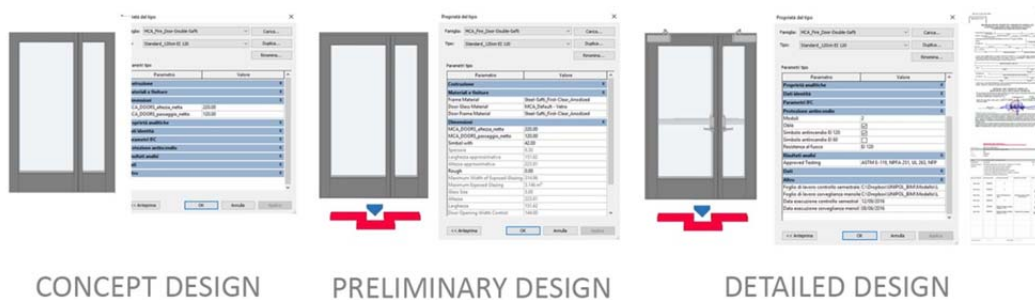

Figure 63: Fire door LODs example.

- **Fire BIM objects and parameters implementation**

As mentioned above, the first step is to transfer all the information and symbols of the fire project into the BIM model as three-dimensional parametric objects and parameters (Amaro, Raimondo, Erba, & Ugliotti, *Il BIM per il Fire Engineering e per il Safety Management*, 2017). This environment definitely favors the ability to identify solutions that leverage the performance approach. In addition, several specific Fire Engineering parameters have been implemented in the virtual model in order to include and control the requirements belonging to the prescriptive fire strategy.

The shared parameters implemented, categorized through thematic groups, mainly refer to the definition of:

- Fire rating of components
- Fire compartment and systems specifications
- Escape routes
- Fire doors
- Fire protection equipment
- Crowding compliance assessment
- Aspects of derogation
- Fire load calculation

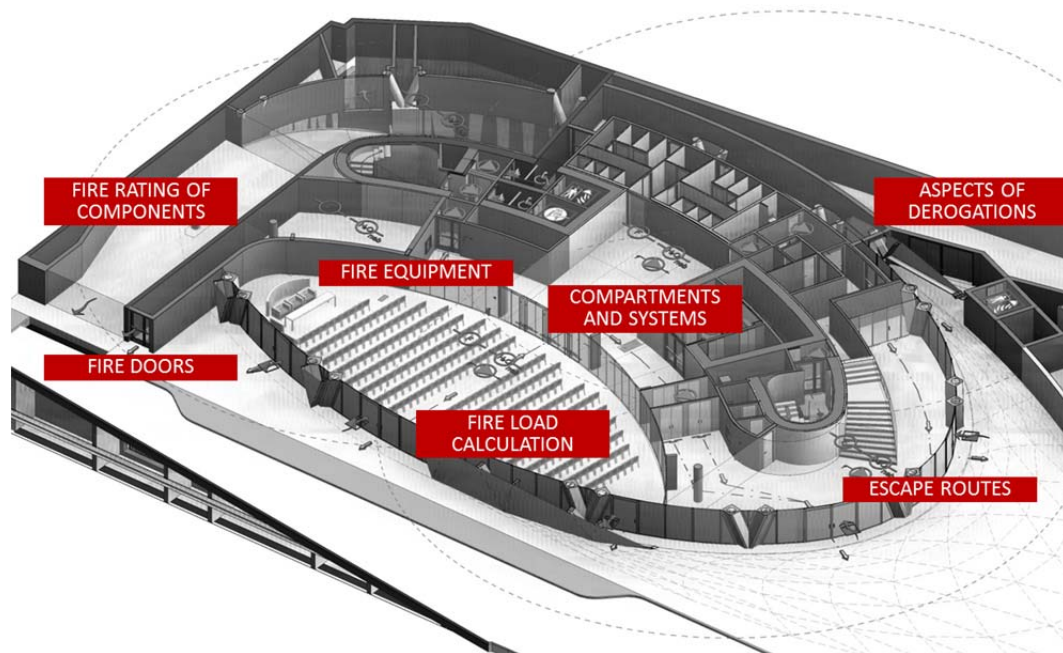

Figure 64: Summary of Fire implementation.

Fire rating of components

The fire resistance characterization of building elements (e.g. walls, pillars, beams, ceilings) is permitted through the *Fire rating* parameter which allows us to mark the objects in the corresponding schedules and to graphically locate them in the project views by applying colored filters as a function of the REI class (green for REI 180 resistance to fire, red for REI 120). This feature gives an immediate indication of the fire project, facilitating spatial definition of fire compartments, and allows the calculation of surfaces / volumes of REI components.

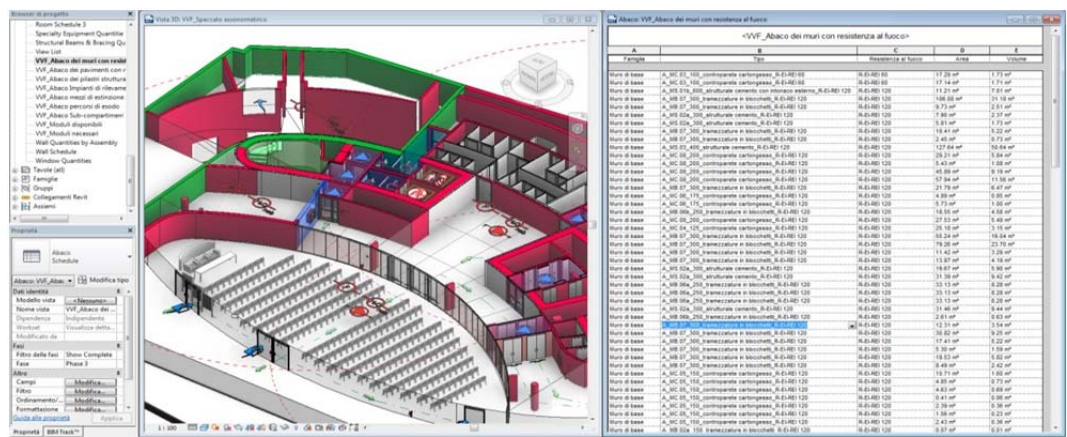

Figure 65: REI wall schedule and themed graphic display.

Fire compartment and systems specifications

According to the fire rating prescriptions, fire compartments have been defined through *Rooms* or *Mass*, in which symbolic objects corresponding to the installed systems have been nested. In this way, by means of the object visibility parameters, it is possible to select with a flag what type of fire system is present in each compartment and visualize them in graphic and tabular form.

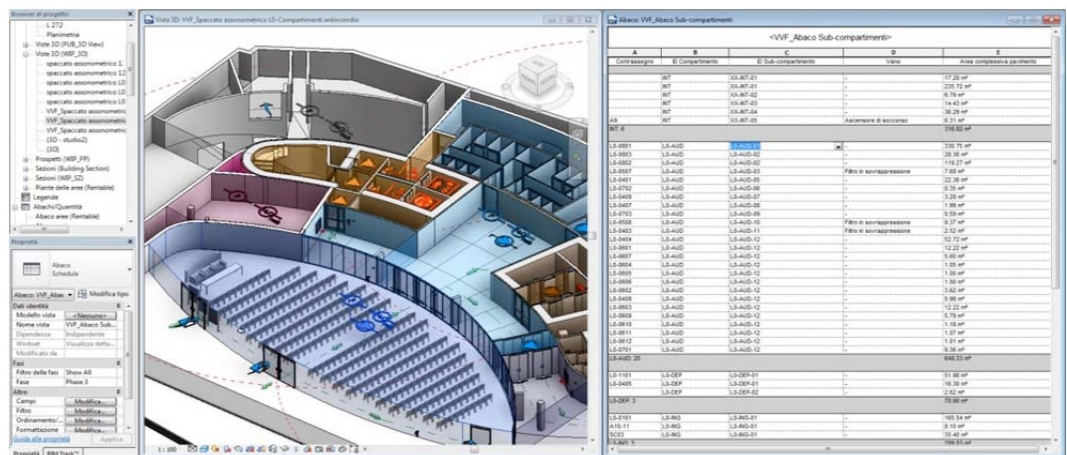

Figure 66: Fire compartments and systems installed schedule.

The specification of the installed systems through objects allows us to verify the fire design choices, thanks to the ability of the system to quickly cross this data with the characteristics of the spaces (e.g. occupants, extension, fire rating, intended use) through the relational database. For example, in the case of introducing an automatic engine shutdown system in a fire compartment, it is possible to trace immediately to the load-bearing structures that delimit it to reduce their fire rating value. The relationship between fire compartments and systems can be verified by setting ad-hoc schedules and displaying them through the creation of themed views according to the associated parameters. These features are very useful to the fire designer for defining the strategy but also to provide an easy verification tool during the authorization phase.

The representation of the spaces through three-dimensional volumes allows us to overcome the display limits of the Rooms in Revit, which are visible only in bi-dimensional views. However, masses are to be implemented ad hoc for each space to make the volumes visible in 3D, making this implementation costly in terms of time though with greater graphics performance. At parametric information level, both solutions are valid.

Escape routes

The horizontal and vertical travel distance to exits (upwards and / or downwards) has been created by a customized families, grouped into *Assemblies* in order to automatically calculate and verify the relative lengths. Such objects consist of straight lines, which contribute to the definition of the exodus path length, and of arrow-shaped elements which identify the direction of travel. In order to obtain a precise and reliable indication of the lengths, the objects placed on vertical paths are drawn on inclined planes, and it is possible to not include in the calculation the traits within safe places by introducing a *Yes/No* parameter as discriminant.

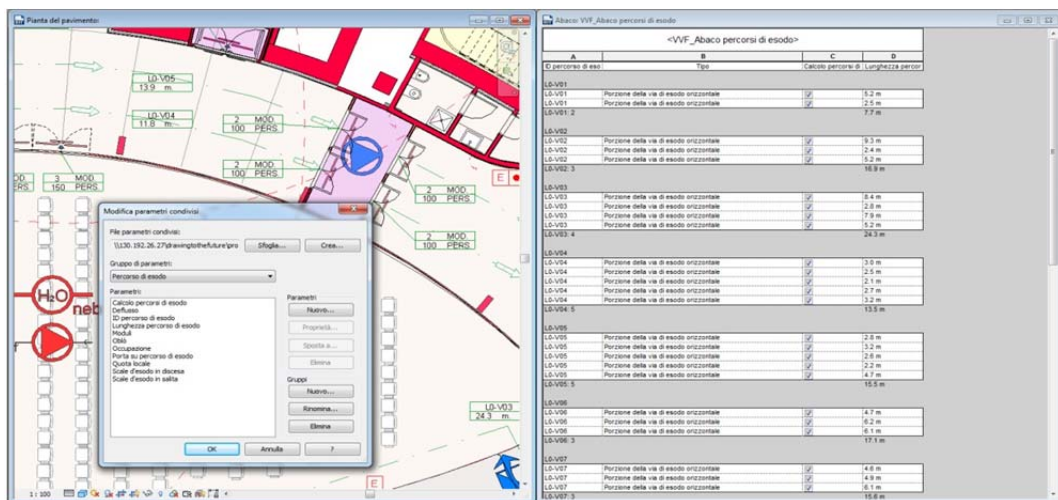

Figure 67: Escape routes objects and parameters.

In this way both the traditional graphic representation and the functionality given by parametric objects are met. By setting a dedicated schedule, it is possible to verify the compliance of the escape routes length requirement in accordance with the current legislation in a dynamic manner, even with respect to a variety of scenarios. Even the stairs are graphically marked by the traditional yellow (downhill escape stairs) and green (uphill escape stairs) colors by using a shared parameter and applying a filter in the project views.

Fire doors

Information associated to fire doors, is defined according to the previously illustrated LODs, and includes the symbolism foreseen by the fire project. Similarly to the load-bearing structures, fire resistance requirements (EI) have been implemented, besides their possible emergency exit function and the presence of handlebars / portholes. Moreover, during the design, it is possible to check the necessary/available egress modules along the escape route or in a specific room by introducing appropriate parameters and using conditional statements allowed by schedules. During the management, the same functionality can be verified as a function of the exhibit/furniture set-up, introducing a *Yes/No* parameter for the availability of use. The parameters introduced can also be automatically recalled through two-dimensional labels, so they can also be displayed in plan views.

Abaco: VVF_Moduli necessari

A	B	C	D	E	F
Livello	Numero	Reparto	Nome	Occupazione	Moduli necessari al deflusso
L0	0101	ATRII	accesso piano terra/foyer sala co	72	2
L0	0801	CONFERENZE/EVENTI	sala conferenze	276	6
L0	0802	CONFERENZE/EVENTI	area eventi/spazio espositivo	59	2

Abaco: VVF_Moduli disponibili

A	B	C	D	E	F	G	H	I	J	K	L
Livello	Numero	Reparto	Da locale: Nome	Occupazione	Tipo	Resistenza al fuoco	Porta su percorso d	Disponibile	Larghezza	Moduli	Deflusso massimo
L0	0101	ATRII	accesso piano terra/foyer	72	MCA_1200x2200		<input checked="" type="checkbox"/>	<input checked="" type="checkbox"/>	150.0	2	100
L0	0101	ATRII	accesso piano terra/foyer	72	MCA_1200x2200		<input checked="" type="checkbox"/>	<input checked="" type="checkbox"/>	150.0	2	100
L0	0101	ATRII	accesso piano terra/foyer	72	MCA_1200x2200		<input checked="" type="checkbox"/>	<input checked="" type="checkbox"/>	150.0	2	100
L0	0101	ATRII	accesso piano terra/foyer	72	MCA_1200x2200		<input checked="" type="checkbox"/>	<input checked="" type="checkbox"/>	150.0	2	100
0101: 4										8	400
L0	0801	CONFERENZE/EVENTI	sala conferenze	276	MCA_Vetro Doppia EI 60		<input checked="" type="checkbox"/>	<input checked="" type="checkbox"/>	180.0	3	150
L0	0801	CONFERENZE/EVENTI	sala conferenze	276	MCA_Vetro Doppia EI 60		<input checked="" type="checkbox"/>	<input checked="" type="checkbox"/>	180.0	3	150
L0	0801	CONFERENZE/EVENTI	sala conferenze	276	MCA_Vetro Doppia EI 60		<input checked="" type="checkbox"/>	<input checked="" type="checkbox"/>	180.0	3	150
L0	0801	CONFERENZE/EVENTI	sala conferenze	276	MCA_1200x2200		<input checked="" type="checkbox"/>	<input checked="" type="checkbox"/>	147.0	2	100
L0	0801	CONFERENZE/EVENTI	sala conferenze	276	MCA_1200x2200		<input checked="" type="checkbox"/>	<input checked="" type="checkbox"/>	150.0	2	100
L0	0801	CONFERENZE/EVENTI	sala conferenze	276	MCA_1200x2200		<input checked="" type="checkbox"/>	<input checked="" type="checkbox"/>	146.8	2	100
L0	0801	CONFERENZE/EVENTI	sala conferenze	276	MCA_1200x2200		<input checked="" type="checkbox"/>	<input checked="" type="checkbox"/>	146.8	2	100
L0	0801	CONFERENZE/EVENTI	sala conferenze	276	MCA_1200x2200		<input checked="" type="checkbox"/>	<input checked="" type="checkbox"/>	146.4	2	100
0801: 8										19	950
L0	0802	CONFERENZE/EVENTI	area eventi/spazio espositi	59	130 x 220 cm EI 60 EI 60		<input checked="" type="checkbox"/>	<input checked="" type="checkbox"/>	130.0	2	100
L0	0802	CONFERENZE/EVENTI	area eventi/spazio espositi	59	130 x 220 cm EI 60 EI 60		<input checked="" type="checkbox"/>	<input checked="" type="checkbox"/>	130.0	2	100
L0	0802	CONFERENZE/EVENTI	area eventi/spazio espositi	59	120 x 220 cm EI 12 EI 120		<input checked="" type="checkbox"/>	<input checked="" type="checkbox"/>	120.0	2	100
0802: 3										6	300

Figure 68: Necessary/available egress modules check.

Fire protection equipment

The extinguishing and signaling means has been inserted into the model by special loadable families, integrated with two-dimensional elements to ensure the same graphic representation in the plan views as defined by the legislation. Furthermore, the range of action of fixed extinguishing plant terminals is represented for the coverage area verification. The elements are directly computable and constitute part of the building inventory. In this way, information about assets such as code, typology, position, extinguishing capacity, manufacturer can be organized automatically in a structured way by schedules, being immediately available to populate the building registry of CAFM or CMMS information systems for maintenance management. However, during the handover phase, it is necessary to integrate the technical documentation of individual components through external documents or management platform links, to avoid losing information and facilitating the startup of operations.

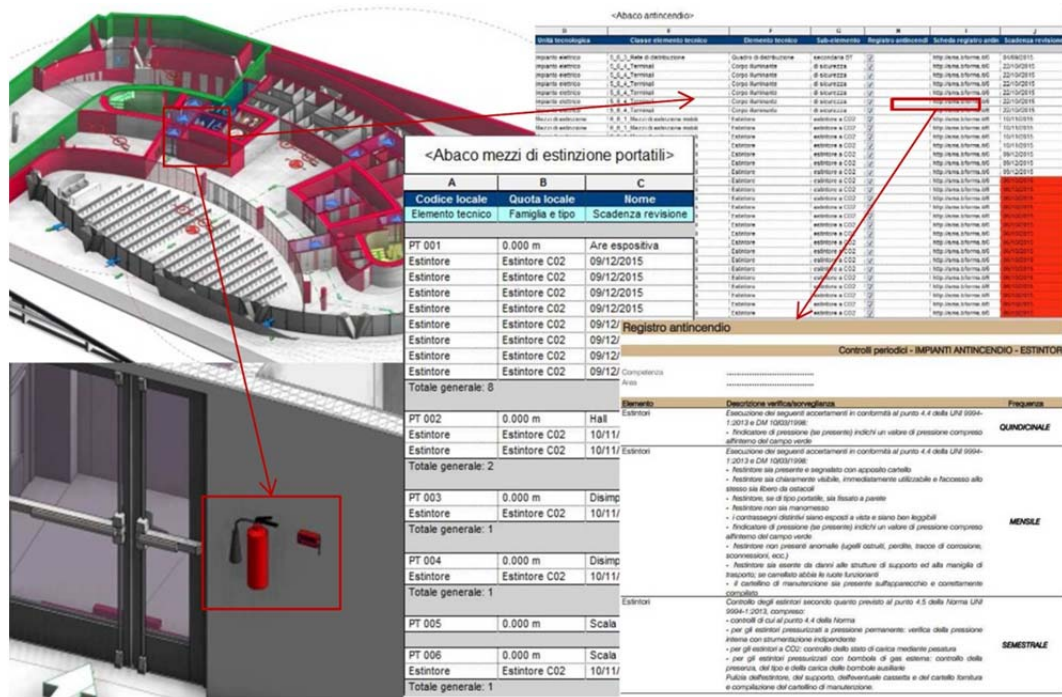

Figure 69: Extinguishing means inventory.

Crowding compliance assessment

Each *Room/Mass* is associated with parameters that identify the capacity / maximum crowding expected for that space. Through the corresponding schedules, the compliance of these values with respect to the normative predictions can be verified considering parameters such as intended use, level of the floor, number and type of exit routes. Similarly, it is also possible to manage the crowding on specific floor plan or on adjacent planes by verifying fire and systems requirements through conditional instructions.

Aspects of derogation

The fire project is also illustrated by a technical report that deepens the content and justifies any aspects of the derogation from the requirements of the legislation. In order to contextualize the aspects of the derogation, it is very useful to spatially identify the areas of the building to which they are related. For this reason, a loadable family has been customized and placed in correspondence of these spaces. The exclamation point shape of the object immediately recalls the attention of the user and it can be interrogated by displaying the textual indications included in the report through an *URL* parameter. In this way, it is possible to collect easily the derogation aspects, facilitating their understanding and viewing by the Fire Brigade during the authorization phase.

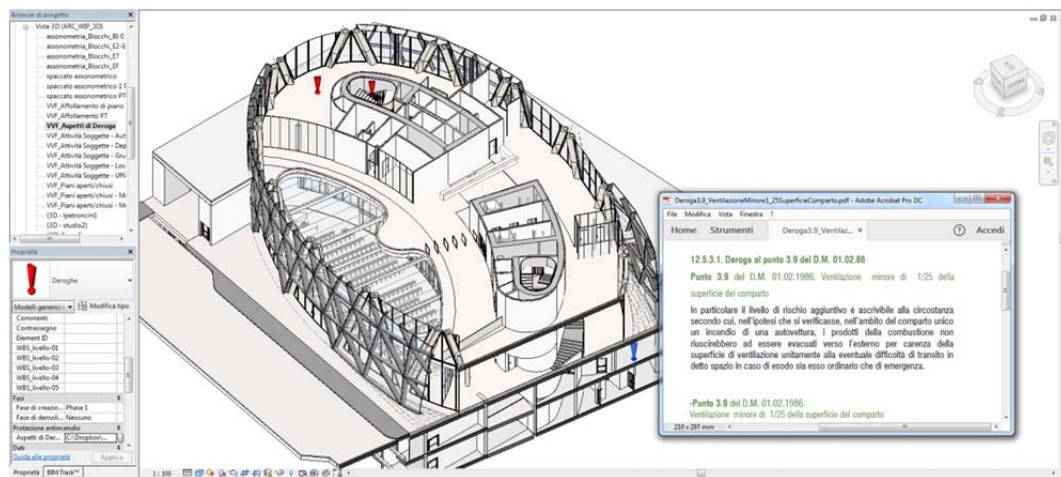

Figure 70: Aspects of derogation through customized family.

- **Fire load calculation**

The setup of this functionality within the BIM model, is certainly a significant contribution in this research. The concept of specific fire load is closely related to the objects that constitute the parametric model and their characteristics (i.e. quantity/extension, material, calorific value). It indicates the quantity of heat liberated per unit area when a building and its contents are completely burnt and it is the reference for the classification of the occupancies. Regarding this, the Italian legislation provides the following expressions *Eq. (1)*, *Eq. (2)*.

$$q_{f,d} = \delta q_1 \cdot \delta q_2 \cdot \delta n \cdot q_f \quad (1)$$

where

- δq_1 is the factor that takes account of fire risk in relation to the size of compartment,
- δq_2 is the factor that takes account of fire risk in relation to the type of activities carried out in the compartment,
- δn is the factor that takes account of the different protection measures,
- q_f is the nominal value of the specific fire load.

$$q_f = \frac{\sum g_i \cdot H_i \cdot m_i \cdot \psi_i}{A} \quad (2)$$

where

- g_i is the mass of the i-th combustible material [kg],
- H_i is the lower calorific value of the i-th combustible material [MJ/kg],
- m_i is the combustion participation factor of the i-th combustible material,
- ψ_i is the combustion participation limiting factor of the i-th combustible material,
- A is the gross surface area of the compartment.

In particular, the factors of the *Eq. (2)* can be directly correlated to the model objects as characteristics of the individual components. Firstly, it is necessary to make recognizable the building components that contribute to the calculation – such as furniture, walls, ceilings – by assigning a common parameter for grouping them within the same schedule. Since both systems and loadable families, as well as materials need to be displayed together, the only possibility using Autodesk Revit is to set a schedule of materials filtering elements by the common shared parameter introduced.

Typically, the fire load is calculated and verified for the most significant spaces of the building in terms of occupancy (e.g. conference rooms, open space offices) or

for the presence of combustible material inside (e.g. archives / technical rooms). In the new UnipolSai Headquarter case study, the offices floor plans and the auditorium have been analyzed in order to test the applied methodology on different contexts / objects (Amaro, Raimondo, Erba, & Ugliotti, A BIM-based approach supporting Fire Engineering, 2017). According to the offices layout project, as shown in *Fig. 3*, chairs and stools, desks and documents cabinets have to be taken into account as well as the elements delimiting the fire compartment such as ceiling, wall, false ceiling, which are characterized by a wooden surface finishing.



Figure 71: Design offices layout of the new UnipolSai headquarter.

Source: <http://www.mcarchitects.it/project/centro-direzionale-unipolsai#>

Depending on the elements types, there are different methods to calculate their specific contribution. As is it possible to see from the different units of measure in the table below, the nominal value of the specific fire load can be related to element units in the case of countable elements (e.g. chairs), to the weight of objects when the total mass of combustible material need to be considered (e.g. furniture or finishing made by wood), to surface for cabinets and to volume for paper documents. If not present, it is necessary to model through simple objects the size of paper documents placed on shelves or cabinets. According to this, additional shared or calculated parameters has been implemented to the Revit families.

Table 9 Parameters for specific fire load calculation

Units of measure	Families	Parameters
[MJ/unit]	Chairs, stools	[MJ/unit] [mi] [yi]
[MJ/kg]	Desks, Ceiling, Wall Finishes, False ceilings	[kg/m ³] [MJ/kg] [mi] [yi]
[MJ/ m ²]	Documents cabinets	[surface] [MJ/m ²] [mi] [yi]
[MJ/ m ³]	Documents paper	[MJ/m ³] [mi] [yi]



Figure 72: Desk parameters for specific fire load calculation.

Then it has been possible to implement a calculation algorithm in the modeling software as stated in figure below. In order to make compatible the units of measures within Revit, the part of qf calculation which contains Surfaces and Volumes, automatically generated by the software, has been divided by respective dimensional units (m^2 , m^3).

$$qf = \left(\frac{[MJ/uni]}{1\ m^3} \cdot mi \cdot yi \right) + \left(\frac{(\text{Material: Volume } [[kg/m^3]]) \cdot [MJ/kg]}{1\ m^3} \cdot mi \cdot yi \right) + \left(\frac{(\text{Surface } [[MJ/m^2]]) \cdot mi \cdot yi}{1\ m^2} \right) + \left(\frac{(\text{Material: Volume } [[MJ/m^3]]) \cdot mi \cdot yi}{1\ m^3} \right) \quad (3)$$

A	B	C	D	E	F	G	H	I	J	K	L	M	N	O	P	Q
Famiglia	Tipo	Materiale	Materiale	Volume	Superficie	[kg/m ³]	kg	[MJ/kg]	[MJ/pezzo]	[MJ/m ²]	[MJ/m ³]	mi	yi	MJ	qf [MJ/m ²]	qf ₀ [MJ/m ²]
Armadio documenti tipo 1	40x100x213 cm	Scaffale Legno	82.48 m ²	0.74 m ³	2.13 m ²	0	0	0	0	418	0	0.8	1	17.123.42	24.71	13.07
Armadio documenti tipo 1: 24			82.48 m ²	0.74 m ³	2.13 m ²	0	0	0	0	418	0	0.8	1	17.123.42	24.71	13.07
Armadio documenti tipo 2	10x90x213 cm	Scaffale Legno	18.31 m ²	0.16 m ³	1.92 m ²	0	0	0	0	418	0	0.8	1	4.494.90	6.49	3.43
Armadio documenti tipo 2: 7			18.31 m ²	0.16 m ³	1.92 m ²	0	0	0	0	418	0	0.8	1	4.494.90	6.49	3.43
Armadio documenti tipo 3	40x100x210 cm	Scaffale Legno	106.43 m ²	0.96 m ³	2.20 m ²	0	0	0	0	418	0	0.8	1	22.070.40	31.85	16.84
Armadio documenti tipo 3: 30			106.43 m ²	0.96 m ³	2.20 m ²	0	0	0	0	418	0	0.8	1	22.070.40	31.85	16.84
Controsoffitto composto	CT01_25_controsoffitto_Boiserie	Boiserie legno spessore 2.5 cm	426.25 m ²	10.66 m ³	0.00 m ²	550	5836	17	0	0	0	0.8	1	79.708.71	115.03	60.82
Controsoffitto composto: 1			426.25 m ²	10.66 m ³	0.00 m ²	550	5836	17	0	0	0	0.8	1	79.708.71	115.03	60.82
Documenti tipo 1: 24	Documenti tipo 1	Documenti	162.34 m ²	20.45 m ³	0.00 m ²	0	0	0	0	1700	0	0.8	1	27.809.28	40.13	21.22
Documenti tipo 2: 7	Documenti tipo 2	Documenti	39.56 m ²	4.03 m ³	0.00 m ²	0	0	0	0	1700	0	0.8	1	5.474.95	7.90	4.18
Documenti tipo 3: 30	Documenti tipo 3	Documenti	208.80 m ²	26.40 m ³	0.00 m ²	0	0	0	0	1700	0	0.8	1	35.904.00	51.81	27.40
Muro di base 33		Boiserie legno spessore 2.5 cm	434.09 m ²	10.84 m ³	0.00 m ²	550	5962	17	0	0	0	0.8	1	81.086.90	117.02	61.87
Pavimento 1	A_PS_02_200_pavimento sopraelevato	Legno spessore 4 cm	692.95 m ²	27.72 m ³	0.00 m ²	550	17866.66	17	0	0	0	0.8	1	207.329.3	299.20	158.21
Sedia 76	Sedia non imbottita	Sedia non imbottita	52.66 m ²	0.84 m ³	0.00 m ²	0	0	0	67	0	0	1	1	5.992.00	7.35	3.89
Spabeteo 16	H 76cm	Sedia non imbottita	4.22 m ²	0.02 m ³	0.00 m ²	0	0	0	67	0	0	1	1	1.072.00	1.55	0.82
Tavolo quadrato: 1	180x180 cm (2,56 m ²)	Legno spessore 3 cm	5.31 m ²	0.08 m ³	0.00 m ²	550	42.24	17	0	0	0	0.8	1	574.48	0.83	0.44
Tavolo rettangolare: 52	80x180 cm (1,44 m ²)	Legno spessore 3 cm	157.87 m ²	2.25 m ³	0.00 m ²	550	23.76	17	0	0	0	0.8	1	16.803.07	24.25	12.82
Tavolo tondo tipo 1: 1	Diametro 100 cm (0,785 m ²)	Legno spessore 3 cm	1.66 m ²	0.02 m ³	0.00 m ²	550	12.925	17	0	0	0	0.8	1	176.00	0.25	0.13
Tavolo tondo tipo 2: 1	Diametro 150 cm (1,77 m ²)	Legno spessore 3 cm	3.68 m ²	0.05 m ³	0.00 m ²	550	29.14312	17	0	0	0	0.8	1	396.55	0.57	0.30
Totale generale: 304			2396.62 m ²	105.21 m ³										505.115.9	728.94	385.44

Figure 73: Fire load calculation schedule.

The adopted method allows a dynamic update of the calculations in function of exhibit and layout set-up or materials changes. In this way several scenario can be easily evaluated with limited effort during design, construction and management phases.

- **Exodus simulation**

According to the building utilization and the occupant load of the site, the digital model becomes the environment to perform occupants egress simulation towards safe place and Fire rescue vehicles efficiency and approach. Once the model is characterized by all the elements of fire strategy, some walkthrough path can be created to simulate and to verify the escape route from different floors and by the use of different stairwells.



Figure 74: Fire rescue vehicles approach.
Case study: UnipolSai headquarters, Milan.

Through this mode, which can be set directly into modeling software, it is possible to travel virtually through the exodus path, checking location, accessibility and visibility of the extinguishing and signaling means and the presence of the fire signs thanks to the three-dimensionality of the instrument.

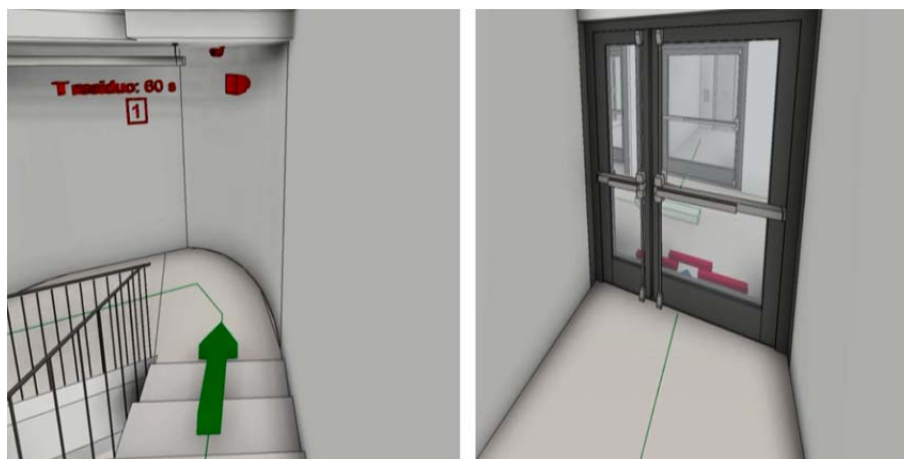

Figure 75: Occupants egress simulation towards safe place.

- **Specialized simulations and data exchange**

Thanks to the interoperability process guaranteed by the exchange formats, the BIM model can be used as the starting point to perform specialized simulations. In this field, static and dynamic analysis of structural elements and their behavior in case of fire as well as Computational Fluid Dynamic Analysis (CFD) simulations are possible. In CFD simulation software such as Pathfinder and PyroSim, used respectively to perform exodus simulation and to evaluate the fire scenario and phenomenon evolution, only the geometry of the model is preserved. However, the automatic acquisition of geometry through the .FBX exchange format allows to optimize the processing time and the accuracy of the simulation, reducing simplifications due to the building remodelling.

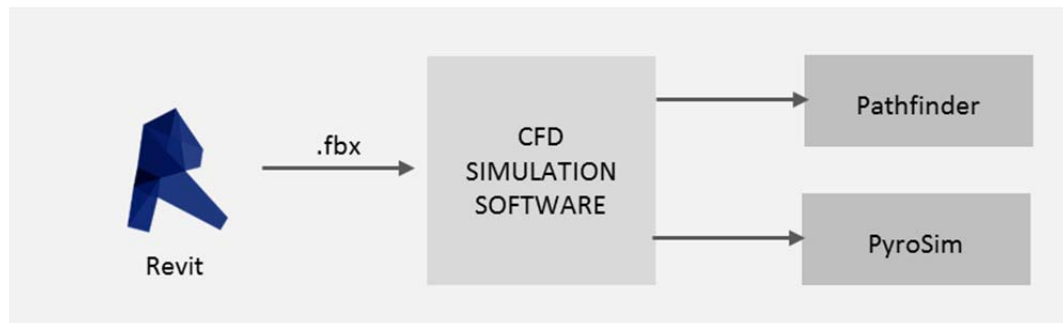

Figure 76: Data exchange with CFD specialized software.

These applications track and monitor the travel times, the dynamics of parking in the areas identified by the Emergency Plan, and places where critical situations can arise (e.g. bottleneck). The results of these simulations can be recalled within the model through *URL* parameters, making them usable at later stages.

- **New presentation mode of the Fire Project**

Considering the applications described so far, the three-dimensional visualization provided by BIM model allows a significant improvement with respect to the authorization phase. Therefore, it is reasonable to expect that in the future new possibilities for presenting the fire project can be adopted starting from BIM models, transferring information in non-editable formats such as IFC and PDF 3D for a more immediate and dynamic consultation by the Fire Brigade. An example of this process is illustrated in the *BIM Data Visualization* chapter.

BIM model is also useful for the Emergency Management providing opportunities for rescuers to know in advance the spaces distribution, the fire extinguishing assets positioning and the fire scenarios through digital representations on mobile devices using Augmented and Virtual Reality as described in later chapters.



Figure 77: BIM model visualization through IFC viewer.
Case study: UnipolSai headquarters, Milan.

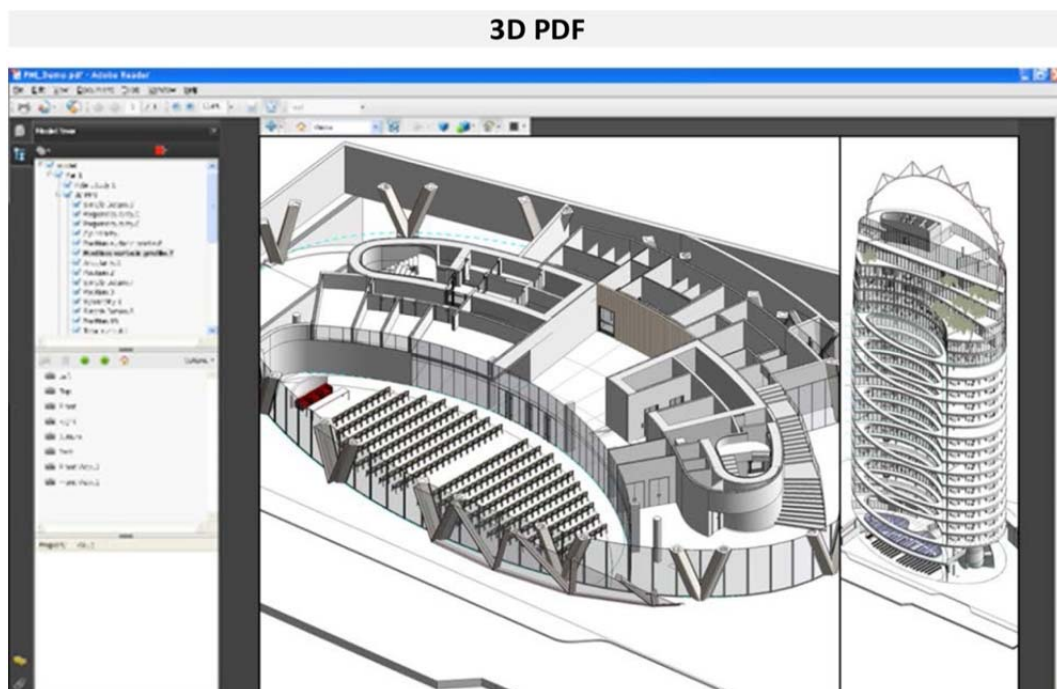

Figure 78: BIM model visualization through PDF 3D.

5.7 Operations and Maintenance

Cost savings is one of the most promising benefits of BIM. As operations and maintenance represent a significant part of the building lifecycle, the creation of a FM BIM model can contribute to streamline these processes helping managers to control costs. In fact, BIM is a shared knowledge resource for information about a facility forming a reliable basis for decisions during its lifecycle from inception onward (National Institute of Building Sciences, 2016). It is crucial for maintenance as it holds comprehensive information on systems component and equipment besides architectural data. In this context, an As built model is very different from an As operate or an As is, as many operational information can be implemented from the early stages of the construction process, at the time they are defined. So the model can be very detailed and all the systems network can be precisely defined. This package of information represents a powerful tool for the Facility Department to manage operations by the possibility to immediately access complete plans and schedules for every component. However, in the case of existing buildings, it is extremely useful to map the main components subject to periodic maintenance, by adopting a reasonable level of detail as a function of the complexity of the building. As not all the systems components are mapped, it is possible to introduce shared parameters in order to include the basic information needed for maintenance. The building registry of the facility provided by the BIM model can be used to populate Computerized Maintenance Management System (CMMS) to organize, schedule, and check the activities within the Maintenance Plan. To do this, it is necessary to have at least the following parameters and information.

Table 10: Parameters for maintenance.

GROUP	PARAMETERS
Classification	Class of technological unit, Technological unit, Class of technical element, Component, Sub component.
Codes	Code, Mark.
Identity data	Description, Materials, Stratigraphy, Image.
Dimensions	Height, Width, Area, Surface, Volume.
Functional connections	Assembly, System, Panel, Switch
Product data	Manufacturer, Model, Serial number, Supplier, Installer.
Localization	Building code, Level, Room, Exposure, Location.
Link	Technical product sheet, O&M manual.

Since each object can have associated more maintenance procedures and strategy, other types of information such as frequencies and costs can be introduced directly into the management platform given the considerable amount of data.

Table 11: BIM for maintenance summary.

DISCIPLINE	MAINTENANCE INFORMATION
STRUCTURES	<p>Generally reinforced concrete structures do not require special maintenance. So, in the case of existing building they can be modelled with a low level of detail and it is sufficient to attribute them the correct function (bearing or not), the type of use (e.g. foundation, elevation) and materials. With regard to steel structures, however, it is important to identify and encode the most significant structural elements and connections (e.g. reticular beam, column, node). In this way maintenance-based assemblies can easily be displayed, both spatially and in tabular form. Despite the representation of these elements being very complex, it is not useful to achieve a high level of graphic detail for existing buildings, but it is appropriate to link the elements to technical details and maintenance procedures.</p>
ARCHITECTURE	<p>The realization of an FM BIM model must provide reliable information regarding the areas and surfaces of the environments and materials used. For this reason, it is necessary to pay maximum attention during the modeling, in order to ensure the correct calculation of the surfaces. Walls and windows are some examples of critical elements. The outer layer of the wall defines the finish, so it is important to model it as needed (e.g. tiles to be cleaned, surface to be painted). While for the fixtures it is useful to estimate the incidence of the glazed part on the frame for cleaning. In this way it is possible to distinguish between the opaque surface and the transparent surface for a facade. Through <i>Revit</i> plug-ins, a summary of the finishes present in each room can be exported, providing valuable quantitative indications for maintenance. Finally, as already pointed out above, it is essential to have a list of doors, windows, as well as rooms.</p>
MEP	<p>Information about systems are the most important for maintenance. An As built provides a detailed representation of all the components, circuits and systems. Thanks to the parametric objects it is possible to identify the functional relations between the elements, allowing to link the generation system, the control units from a terminal component.</p>

For example, in the case of a lighting device, it is possible to know to which electrical switch it is connected, to which electrical panel and consequently to which electrical substation. In the case of a water leak for example, it makes it possible to view the pump involved, to consult the manual and the diagrams, to visualize the various components (VINCI Energies, 2017). This is possible only if all the system network is modelled. In the case of an existing building, it is very difficult to have all this information, scheme and technical drawings. However, the essential maintenance information is the **functional and spatial relationships of the elements**, not the graphic representation. So, in order to complete the cognitive process in As operate and As is models, shared parameters that explain these relationships can be introduced. For example, if there is the need to disconnect the light in a certain area of the building, it is possible to know how many devices are present in those environments, who occupies that part of the building, and which is the reference electrical panel. This type of information represents the added value of the BIM for maintenance activities.

As an example, within the Pala Alpitour case study, the steel structure of the cover of the arena has been implemented in the As operate model so as to be functional to maintenance activities. The main elements have been modeled in *Revit* and have been classified according to UNI 8290. Moreover, they have been grouped in *Assemblies* according to their function to ensure proper recognition if maintenance involves more elements, like a reticular beam or a megacolumn. The graphical representation is simplified even if the elements are correctly identified according to type and shape of the resistant section. In addition, a space subdivisions for areas have been introduced to facilitate their placement in the roof.

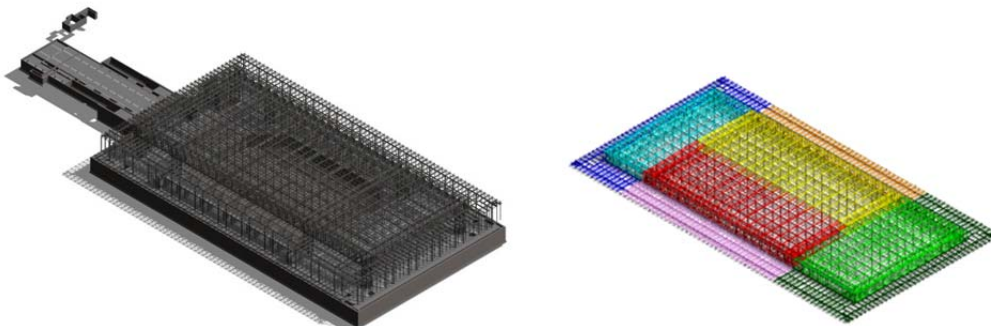

Figure 79: Thematisation of the steel structure by zones.
Case study: Pala Alpitour, Turin.

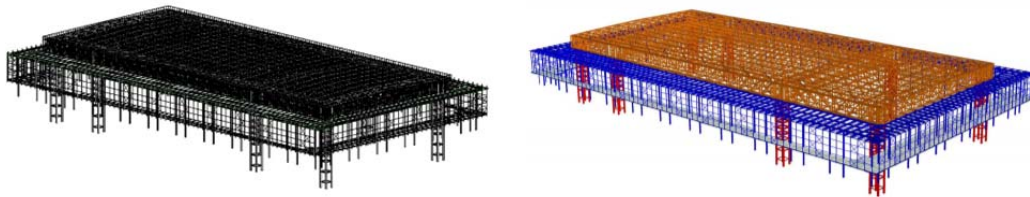

Figure 80: Thematization of the steel structure by technical classification.

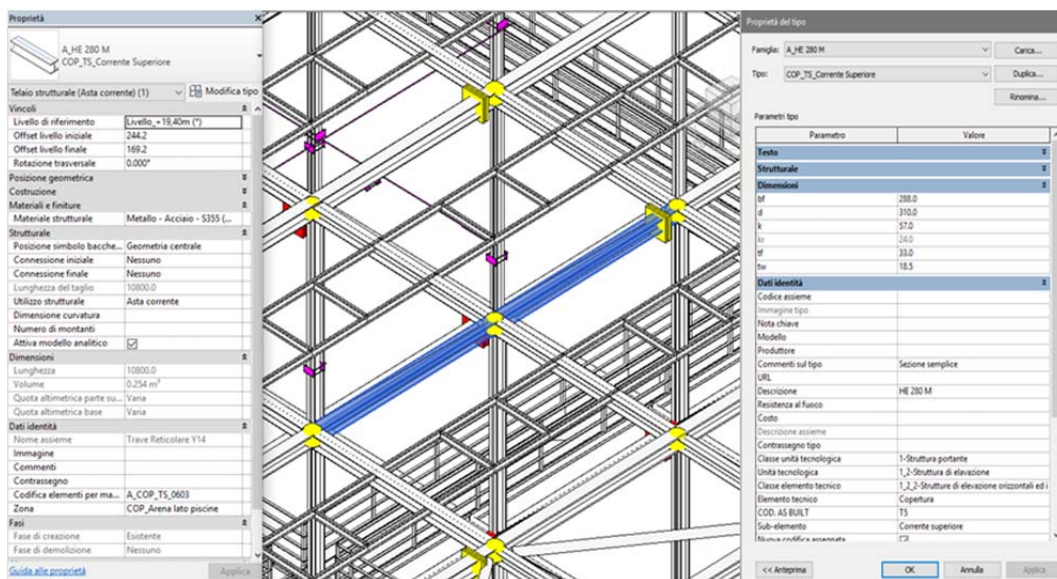

Figure 81: parametric modelling of steel structural auctions.

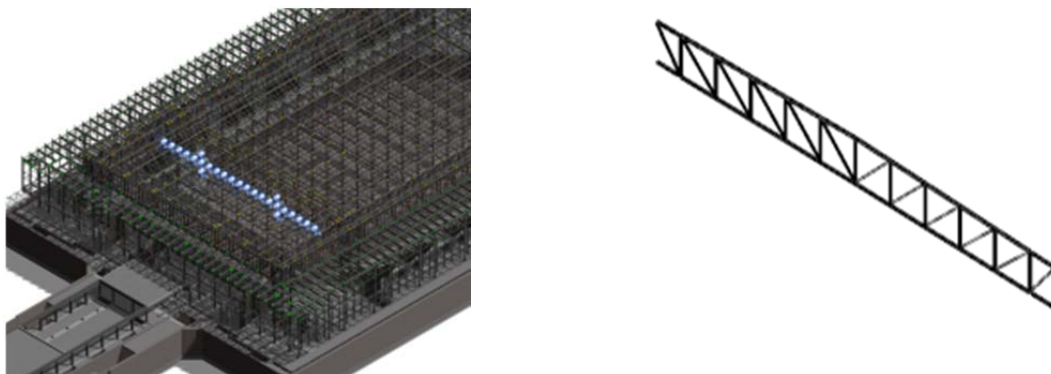

Figure 82: Rods in a reticular beam grouped by Assembly.

In the case of a structural steel knot, this consists of multiple converging rods and connecting devices such as plates or bolts. For maintenance purposes, a knot made up of 8 bolts is similar to a knot made up of 6 bolts, with tightening times and costs almost identical. For this reason, the node has been represented only through a fictitious object, greatly simplifying its graphic representation and speeding up modelling. This entity has been enriched with information such as code, node type, position, by additional parameters, in addition to being linked to a technical file. Through these objects, which can be colored to distinguish their typology, the nodes to be maintained are immediately spatially identifiable. Similarly, auction joints have been implemented, as it is possible to see from the image.

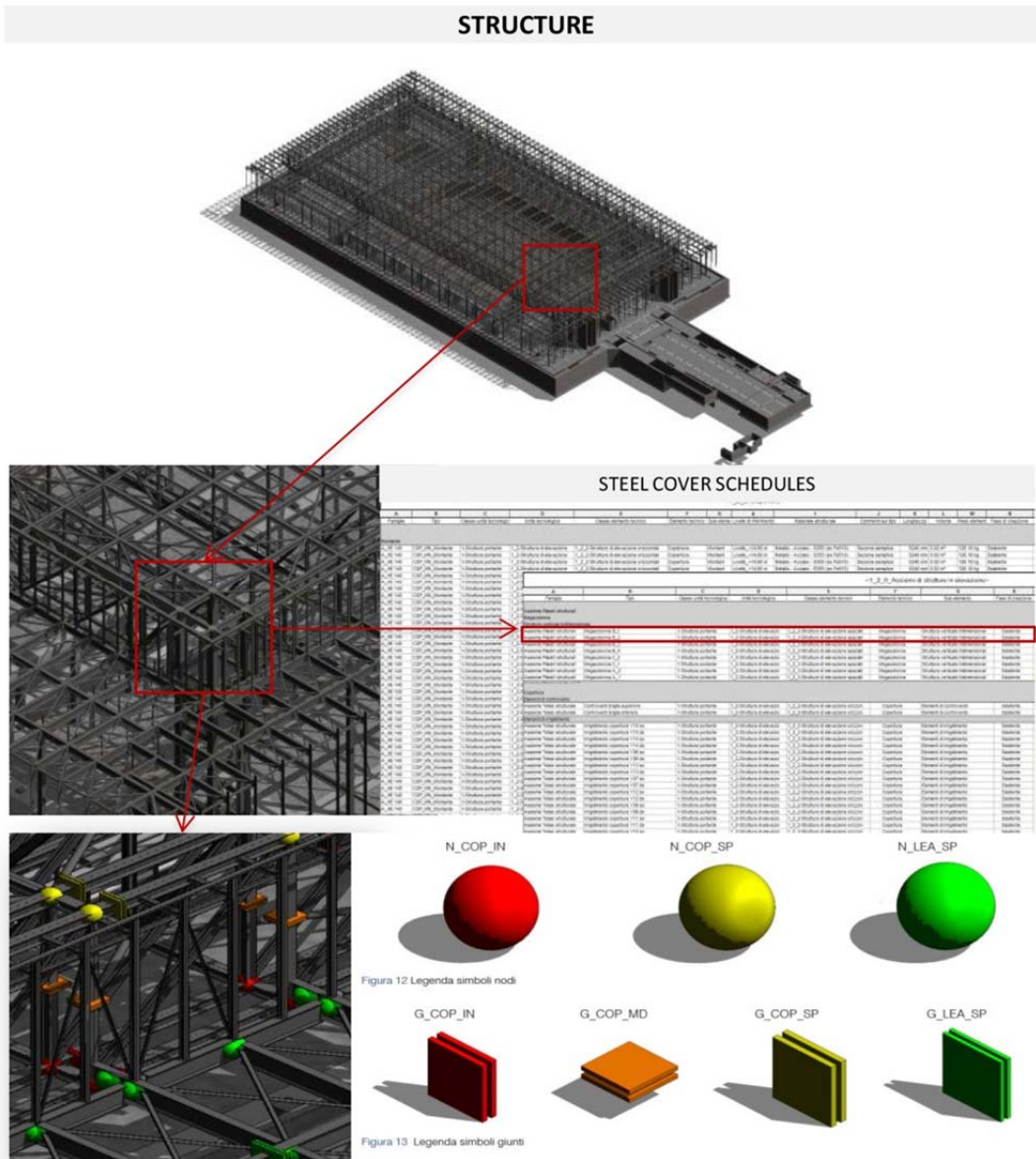

Figure 83: Nodes and connections implementation and management.

Chapter 6

BIM Data Visualization

6.1 Reporting tools

The BIM model is indeed a complete and effective tool for the knowledge of the building, as explained in the previous chapter. However, access to information can turn out to be difficult for non-expert users as well as being necessary to have a software license. Therefore, several solutions are spreading in this moment to navigate the model outside the modelling environment by a user-friendly interface. Most of them are free, while others provide additional functionalities enabling data sharing and collaboration among players or the ability to integrate BIM data with other datasets. By the way of example, two types of model visualization have been tested through a 3D viewer and by the generation of a 3D PDF. In both cases, the targets are facility managers or public bodies in charge of approving projects. The aim is to provide interactive tools that simplify the complexity of BIM models displaying them in the easiest way possible while maintaining the ability to query the data.

- **Viewers**

Autodesk A360 has been used to display the BIM models through a web portal. The application allows us to upload the model in the native *Revit* format storing it in the cloud and to make it available from any device. Through the *A360 Mobile* app for iOS and Android models can be displayed also on tablet and smartphone, boosting the use of the 3D viewer. In this way, it is possible to access large files anywhere and anytime. Navigation takes place through a menu that allows us to visualize building components according to the functional decomposition of the building.

The virtual model cannot be modified, but can be fully queried. For example, the models of the TOBIM project have been loaded into the A360 to allow the Turin City Council to query easily the public buildings under investigation, even in very complex cases such as the one shown in the figure below.

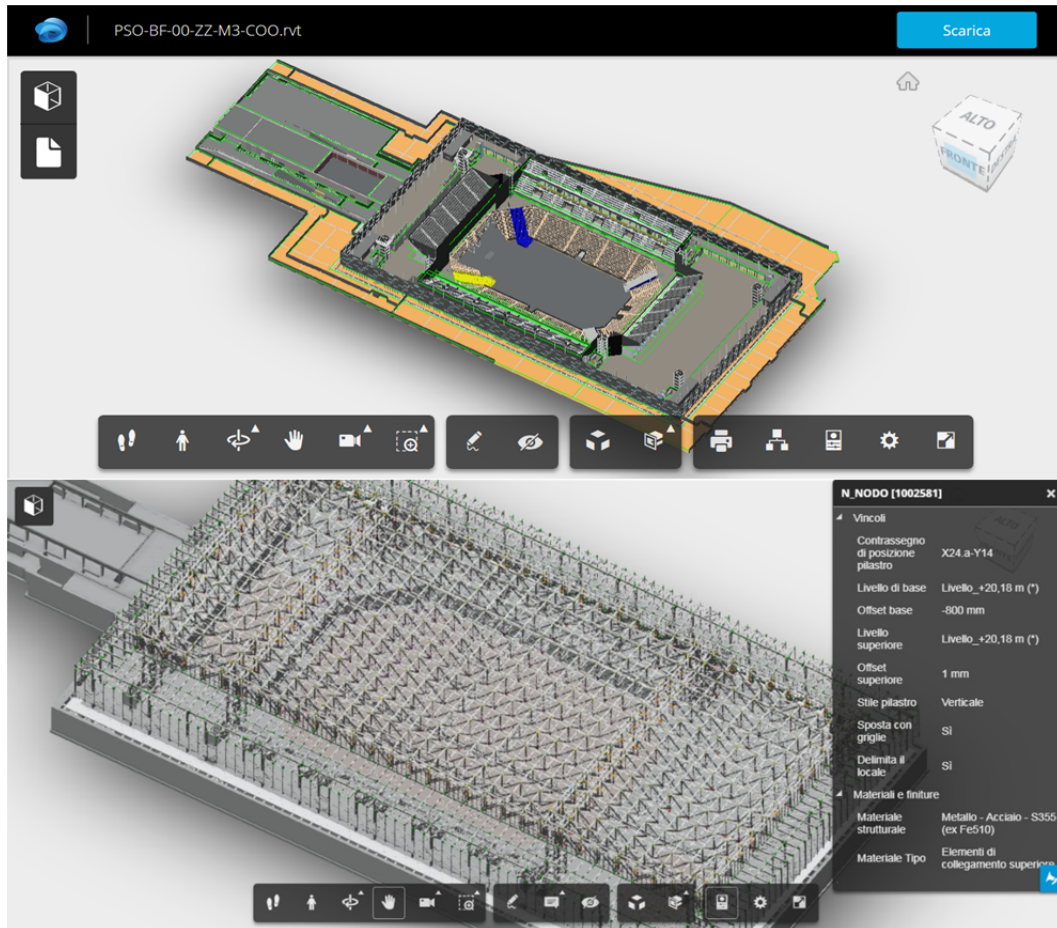

Figure 84: BIM model display through A360 viewer.
Case study: Pala Alpitour, Turin.

The model can be consulted in several ways, by setting default paths or by exploded views and dynamic sections. Dimensions can be measured and all the elements can be interrogated by displaying their properties when selected. In addition, in the latest versions of the software (e.g. 2018) it is possible to visualize views already set in the model such as floorplans schedules or sheets. As this tool enable the worksharing, it is also possible to make comments and manage project revisions through a differentiated user profiling (e.g. only visualization, possibility of modification, administrator). For this reason, this application can be also used as control tool to allow the client to visualize the progress of a BIM model during the design or modelling phase.

- **3D PDF documents**

Processing a 3D PDF has been experimented in order to make the model contents more usable as well as to direct the user to a guided reading mode of information. 3D PDF can be a good tool for all stages of the construction process (i.e. design, authorization phase, construction, management) and for different types of users (operators, marketing, clients) as their capability to compress a 3D model and the embedded data and to filter them for viewing. Every computer, operating system and smart device is familiar with the Portable Document Format (PDF), so the content can be shared and BIM can be accessible to everyone. The generation process has been tested on the UnipolSai Headquarter case study with the aim of exploring a new way to present the fire project within the authorization phase. The conversion between *Revit* 3D BIM metadata into PDF documents is not direct, but driven by the interoperability process. *Safe Software FME* has been used as it is able to convert virtually a large number of format, connecting applications to perform complex enterprise integrations without coding.

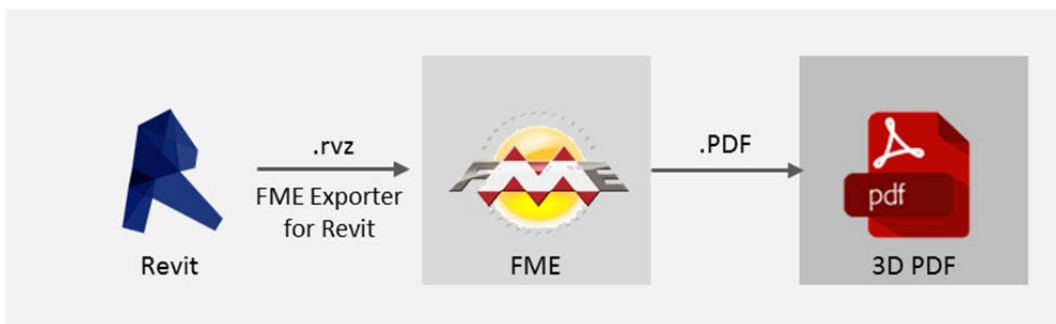

Figure 85: Revit-3D PDF interoperability process.

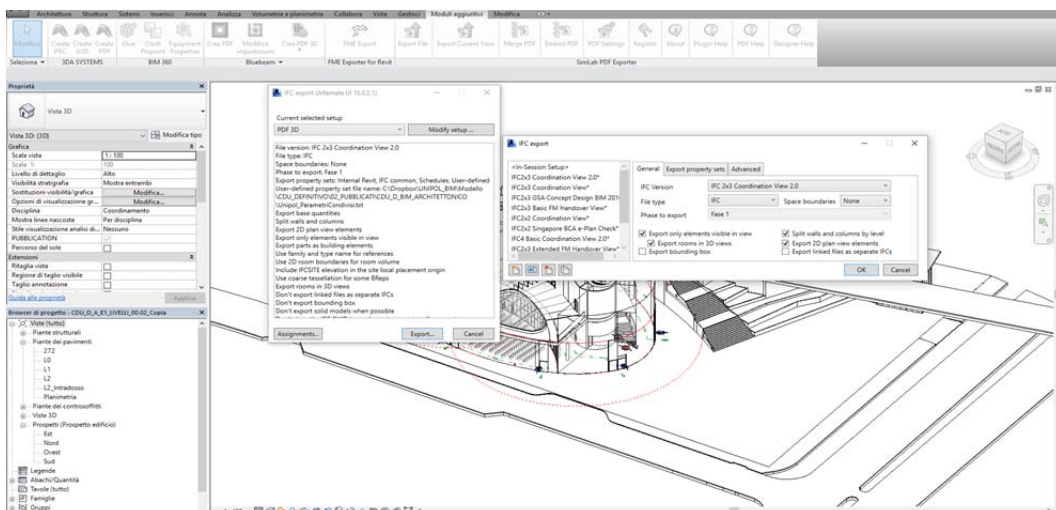

Figure 86: FME Exporter for Revit plug-in.
Case study: UnipolSai headquarters, Milan.

It provides native support for location data, including the complexity of GIS, CAD, and BIM. As a matter of fact, it is possible to export the BIM model in .rvz, a specific format of the program similar to IFC, through a *FME Exporter for Revit* plug-in and subsequently import it into the software. In the conversion process data is preserved, but the display settings defined in the model are not maintained. Therefore, it is necessary to re-process data in order to create thematic views. In the *FME* work environment, the *Workbench* identifies the generation process, in which the imported model works like *Reader*, while the output to be obtained, in this case a 3D PDF, operates as a *Writer*. To obtain a complete control over what data looks like and create thematic views it is necessary to manipulate data using *Transformers*. In this way, the elements attributes can be created or modified and aggregated in different ways. For example, walls have been set according to different transformers in order to visualize them depending on their appearance or coloured depending on fire resistance, as shown in the image below. In the same way, a room can be themed depending on its intended use or the fire compartment to which it belongs. One of the positive aspects for this theming is that the room entity is displayed in 3D as opposed to *Revit*.

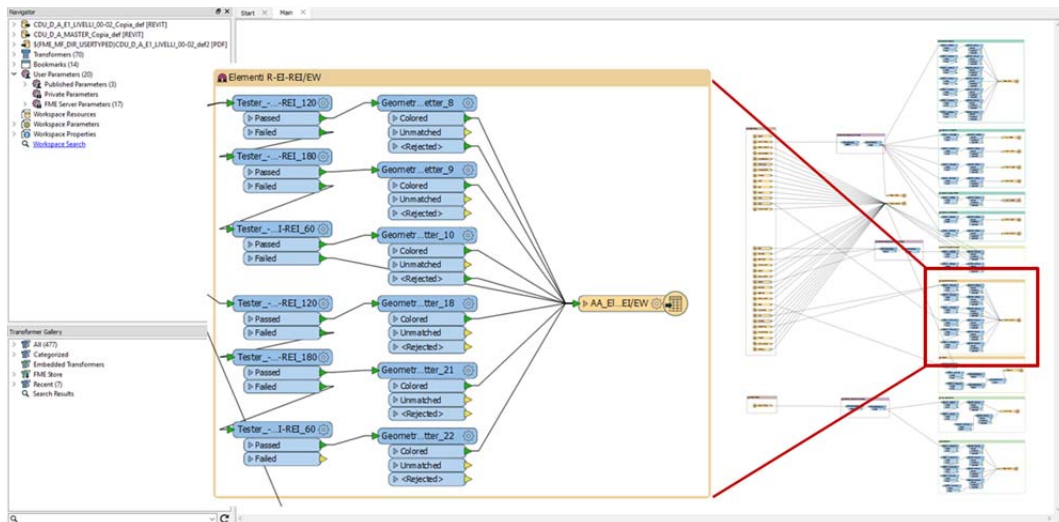

Figure 87: Use of Transformers to generate fire thematic view.

Despite this step currently taking a long processing time and can be very complex, these tools allow to perform powerful data elaborations. One of the most interesting aspects is that the PDF contains the same source file data structure. So, in the case of a parametric model it is possible to maintain the hierarchical tree structure and to visualize objects according to this breakdown. In addition, all FME workflows are reusable and the BIM model can be synchronized if some modification occurred. The use of 3D PDFs can be supported in the project approval phases by the body responsible, which may benefit from intuitive tools that provide greater understanding of the designed space, especially in highly complex environments.

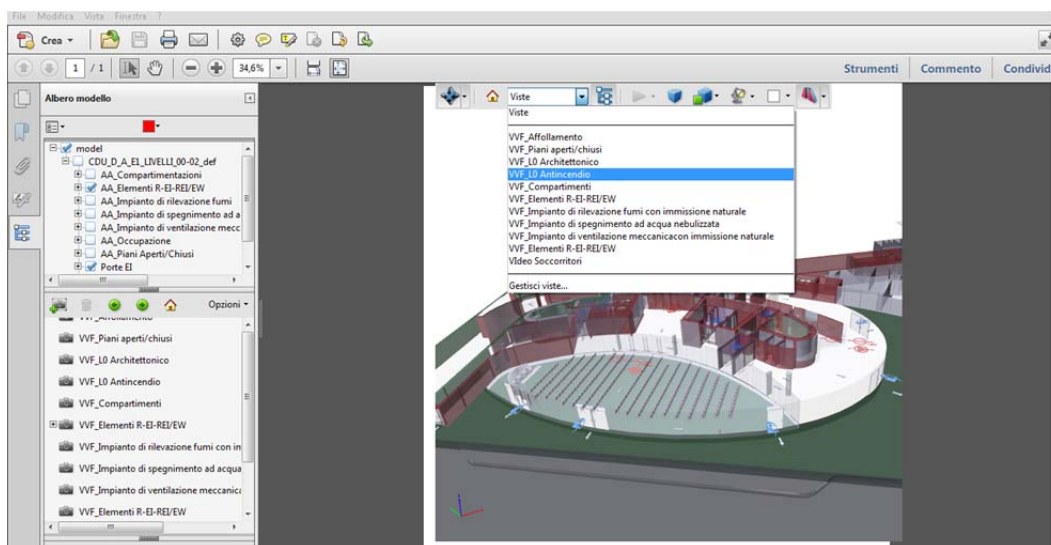

Figure 88: Example of fire project 3D PDF.

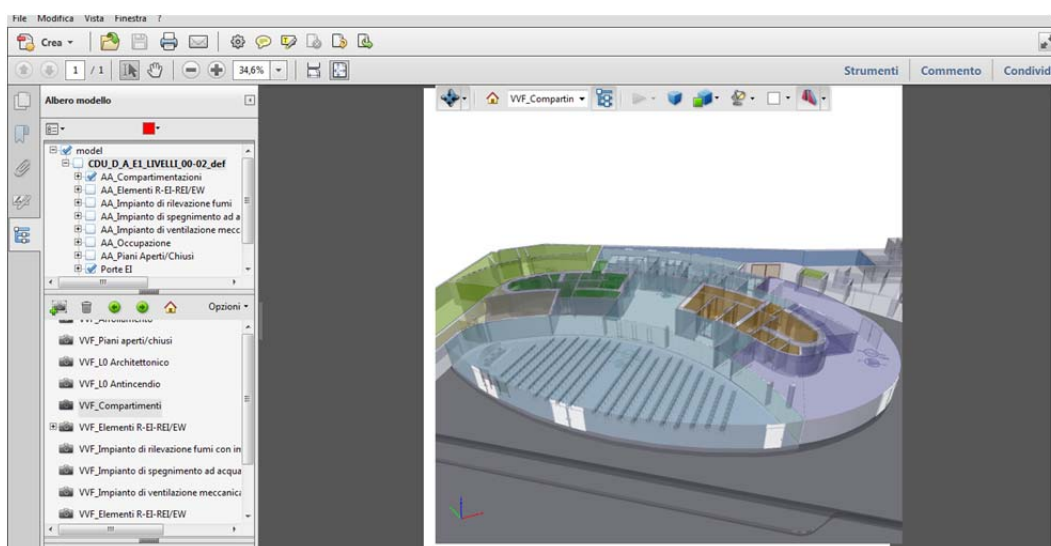

Figure 89: Example of fire compartment thematization.

Another useful application of 3D PDF is to provide a comprehensive and concise document for the actual state representation of a building and its characteristics. This is very useful in the case of large real estate portfolios to have an effective overview of each building. In this sense, this method can be very effective to provide the Public Administration with an easily queryable output for the most important buildings of the city. For example, starting from the BIM model realized within the TOBIM project it is possible to organize data in order to display the most useful information for management related to spaces and systems through thematic views.

6.2 3D Printing

Reproduction of buildings through a 3D printer is another opportunity to evolve from complex digital processing to a more enjoyable representation that fulfills the expressive and communicative function. In fact, BIM models made during the design phase or the reconnaissance of the existing heritage can be exploited also to enhance the knowledge process, expanding the possible users. Obviously it is not convenient to set up a BIM model for this purpose, however, with a few steps, it is possible to have a very useful tool for both designers, city planners and citizens. The scale model of a project is certainly the best way for a designer to present it, while at city level plastics help planners plan and communicate the urban planning of the territory. Similarly, in the case of existing public buildings or of historical importance, 3D printing enables facility managers and citizens an immediate understanding of their shape and main features thanks to a traditional representation, but evolving with the use of technology. The Fused Deposition Modelling technology based on a nozzle which deposits a molten polymer layer after layer on a support structure has been tested. To make the 3D plastic of a building, it is necessary to transfer the BIM model to a type of software called *Slicer* that virtually divides the object into layers and generates the geometric coordinates for printing. As the objective is to obtain a good overall architectural representation at urban level, the geometry model must be calibrated to eliminate the inside part and details too small to be reproduced depending on the size and precision of the printer. The correct exchange format is the Stereo Lithography interface (.STL), mainly used in rapid prototyping, which discretises the geometry in triangles by assigning them spatial coordinates in the three directions. Thanks to the *Revit* plug-in the model can be exported directly to this format and imported into the *Cura* software for the Gcode format generation, containing instructions for numerical control machines. Through the *Slicer* it is possible to check the quality of the geometric data and evaluate appropriate model modifications in order to obtain a better print result. In fact, it is possible to examine the layer-by-layer the nozzle passages being printed, checking in advance complex objects.

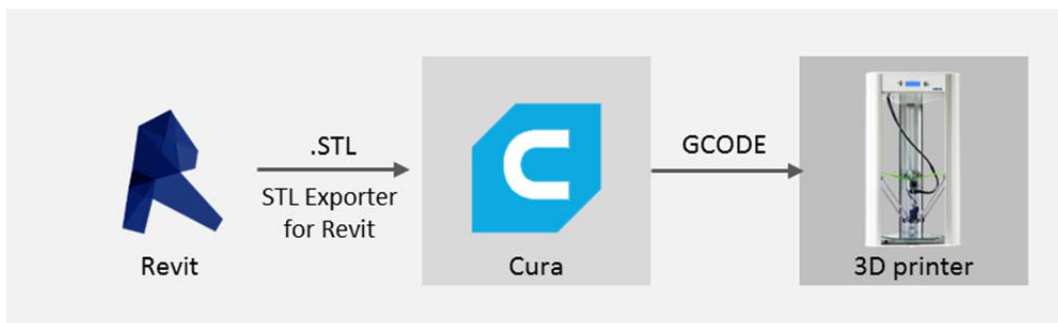

Figure 90: Revit-Cura interoperability process for 3D printing.

For example, whether the model cantilever parts will be properly executed at the printing stage or if supports must be inserted. According to the shape of the model print setup are evaluated. In particular, it is necessary to set the scale of the model, the layer height and thickness, and the infill density. Lower is the layer height, greater the resolution of the model, as well as the speed setting. While the degree of filling provides mechanical resistance to the object and can be checked by moving between the layers as shown in the figure below. Other settings refer to the type of filament used and its melting temperature. Depending on the parameters set, the print time of the object can be controlled.

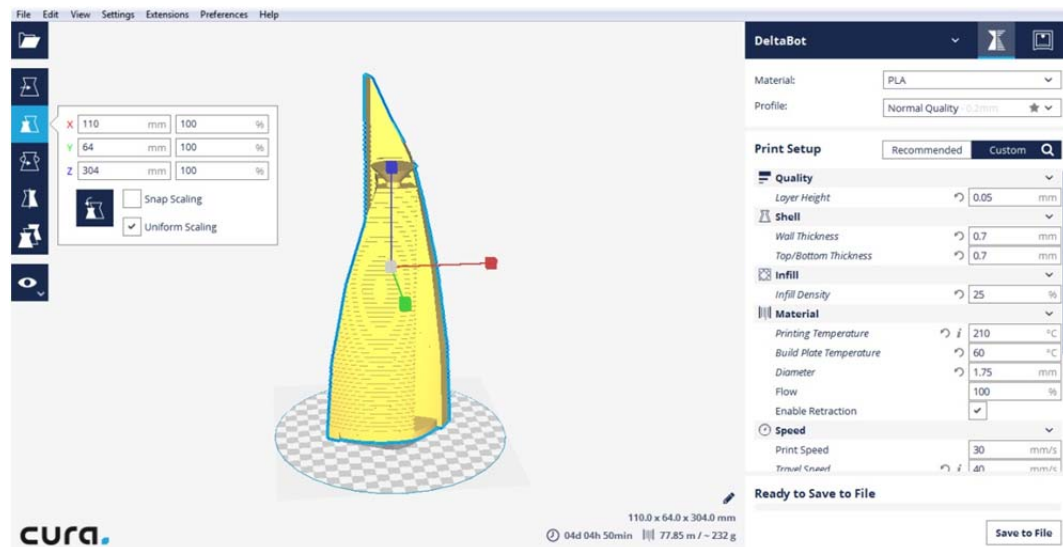

Figure 91: Cura interface and print setup.
Case study: Menara TM, Kuala Lumpur.

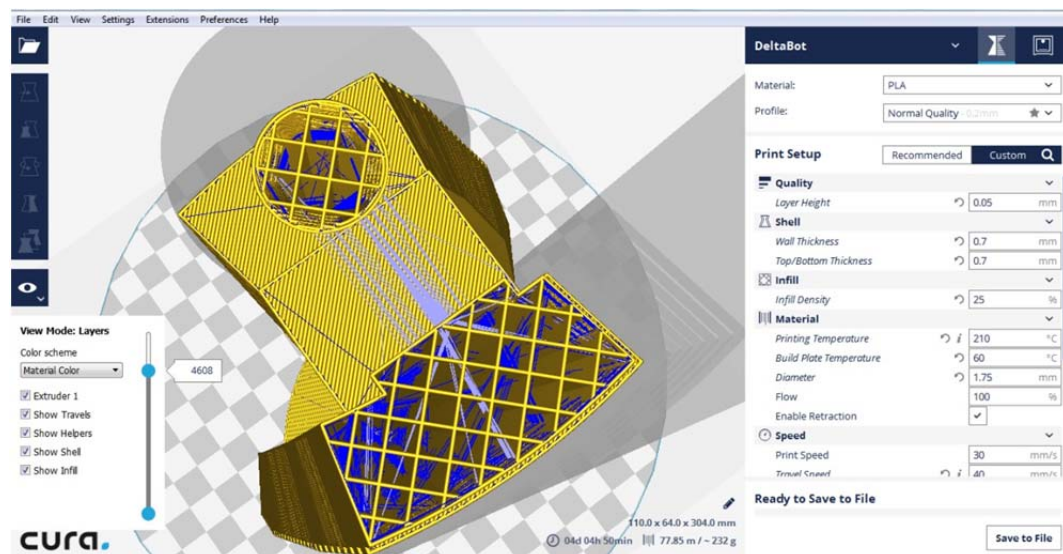

Figure 92: Infill density control.

Finally, the model is transferred to a SD card in the GCode format which is inserted directly from the printer. The images shows the 3D printing of Menara TM, a 77-story skyscraper in Kuala Lumpur, in scale 1: 1000 made with the printer DeltaWASP 20 40. The realization time was 4 days. In case of printing of building cross-section, it is necessary to evaluate if objects have a sufficient thickness to be printed at a given scale. For example, for a proper representation of the 42 floor of this building, it is necessary to set a 1:200 scale and subdivide the model into 8 portions considering 20 cm radius printing plate. In this way, all the internal partition are represented.

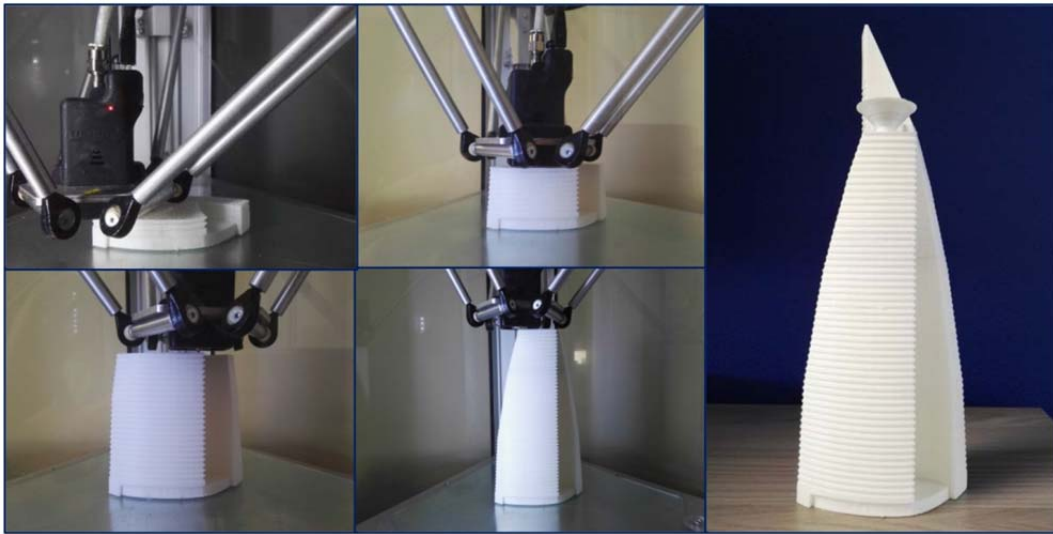

Figure 93: Menara TM printing process.

Moreover, it is possible to enrich the representation using Augmented Reality by the application of dynamic QR Code on the model, allowing the display of additional information that can be updated over time. 3D printing has been exploited due to its great impact to communicate the TOBIM project to the citizens during the European Researchers' Night 2016 besides being one of the outputs of the investigation process carried out on 30 public buildings of the city (Osello & Ugliotti, BIM: verso Il catasto del futuro. Conoscere, digitalizzare, condividere. Il caso studio della Città di Torino, 2017). Moreover, it has been part of the realization of the *Turin BIM Interactive Map* and of the *3D BIM Map* game designed to promote user empowerment within the EEB project, as described in later sections.

6.3 Virtual and Augmented Reality

The powerfulness of BIM associated with innovative technologies enables new promising forms of communication for the built environment. In this field, Virtual Reality (VR) and Augmented (AR) are explored for a stimulating interaction with data from different types of users. In fact, they can be used during building construction and management phases to provide technical information to the AEC sector operators as well as to communicate with end users.

According to recent research interests, **Virtual Reality** engineering is exploited to stimulate the user experience in relation to the knowledge and use of a building and to simplify operations for maintenance activities. It can be described as a realistic and immersive simulation of a three dimensional environment generated by a computer in which a person can naturally interact with the context by movement of the body (Milgram, Takemura, Utsumi, & Kishino, 1995). In this way, it is possible, for example, to have an overall view of the systems network inside a room, or display the maintenance procedure of a mechanical component. The use of this method is spreading in the field of training activities (e.g. fire rescuers, maintainers), providing a highly interactive virtual experience.

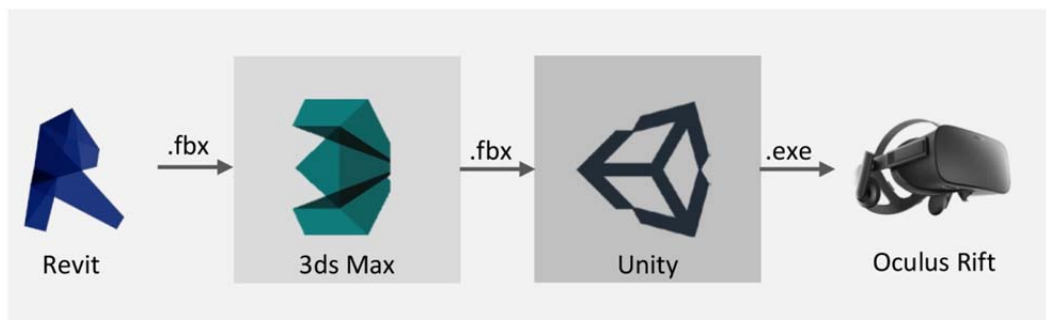

Figure 94: Revit-Unity interoperability process for VR.

To get a virtual tour inside a 3D model *Unity Game Engine* software and *Oculus Rift* stereoscopic viewer have been tested. The Revit model has to be exported by the Filmbox (.FBX) exchange format in Unity. However, information about the geometry and materials are separated in the .FBX, so the model is displayed in grey scale in Unity. To limit this criticality, *Autodesk 3DS Max* has been used as a bridge software to quickly associate textures to all objects of the model, keeping the properties by selecting the “embed media” options during the re-exportation in in .FBX. *Unity* instead is used as interface for setting the scene preparation and procedures for the navigation trough scripts. Finally, an independent application .exe is created for the visualization of the environment through the viewers.

Nevertheless, taking advantage of **Augmented Reality** is surely the quickest and most immediate solution for the dissemination of information. Despite the AR has begun to spread in the entertainment field, its focus is on infotainment (Zanotti, 2015), combining the quantity and quality of information of a specific context with the simplicity of the use of smart device camera. It involves the overlapping of digital content from a two-dimensional static representation with the aim to increase the human sensory perception of the built environment and the available information superimposing (Azuma, 1997)/replacing the reality. Hence a real world environment can be enhanced by adding virtual computer-generated information providing a direct or indirect real time view (Carmigniani & Borko, 2011). Virtual objects containing text, graphics, video and audio can be made visible by using specific devices according to the Reality–Virtuality (RV) continuum approach (Milgram, Takemura, Utsumi, & Kishino, 1995), where real and virtual objects are presented together within a single display defining a generic Mixed Reality (MR) environment. This communication strategy allows the user to access digital content in the right place at the right time, with data that is immediately available without having to search for it (Dalmasso & Ugliotti, 2015). The AR visualization process involves: (i) the virtual object selection (e.g. web site, document, video) / generation (3D model), (ii) the association of this digital content with a marker by the software and the creation of the application, (iii) data display through the use of smart device camera (i.e. smartphone, tablet, computer). The marker is the physical link between the real and the virtual world.

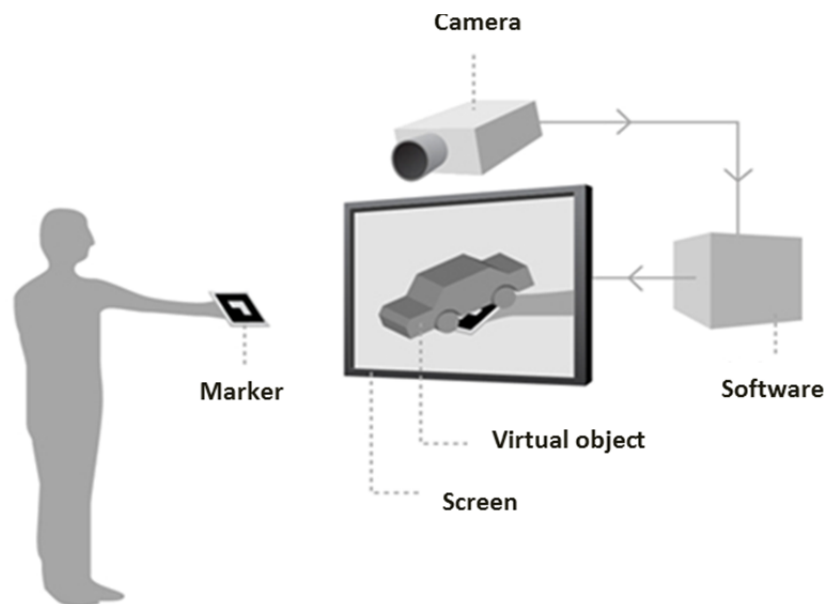

Figure 95: AR visualization process.

Depending on the type of content, 3D models or files, two different processes are applied, as described below.

BIM models AR visualization

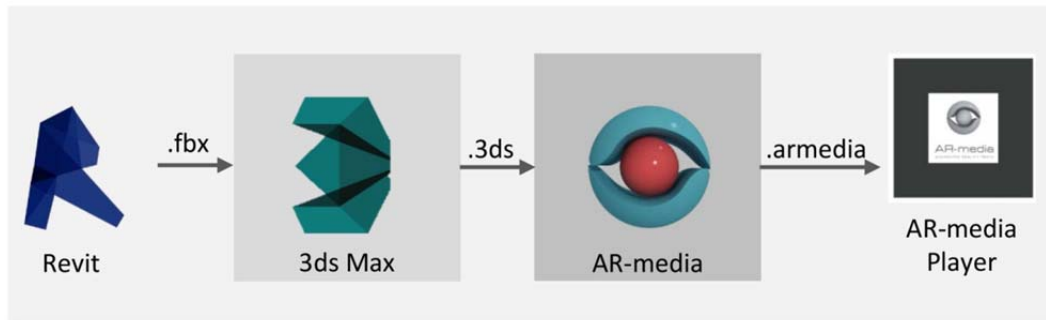

Figure 96: Revit-AR-media interoperability process for AR.

The AR visualization of the *Revit* model has been experienced through the AR-media plug-in for *Autodesk 3DS Max*, by exporting it through *.FBX*. As previously mentioned, data related to the geometry is maintained using this exchange format but materials properties are not graphically displayed. Through “*Combine by Revit Material*” mode, the *Revit* entities assigned to the same material are recognized as a single object in *3DS Max*, speeding up the procedure of material reallocation. Once the model is set, it is possible to link it to a customized marker by the *AR-media* plug-in and to generation of an application (*.armedia*). More markers are allowed within the same project as described later. At this point, by framing the marker with a camera connected to the computer, it is possible to display the model through the *AR-media Player* application. To view it from a smartphone, it is necessary to load the executable into the phone’s memory.

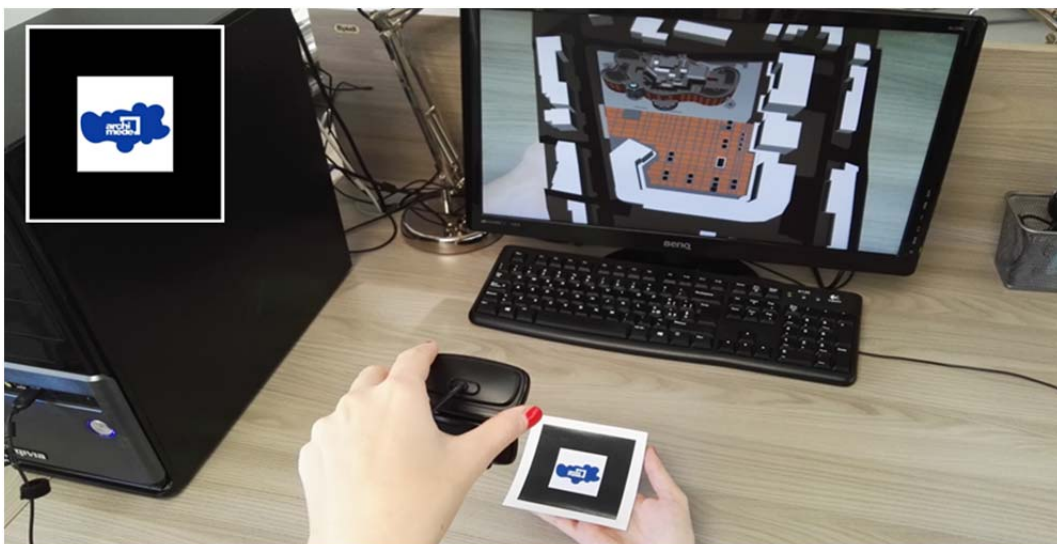

Figure 97: AR BIM model visualization.
EEB Project. Case study: Biblioteca Archimede, modelled by Maurizio Dellosta.

Further experimentation has been performed using 360° rendered images from the Revit model. Through the *Autodesk 360* cloud platform, it is possible to obtain stereoscopic views, by appropriately setting a fulcrum in the model, which can be available in the cloud. Using the relative URL it is possible to create a QR code to display the model on smartphone and tablet besides on computer, also experimenting the VR visualization through Google Cardboard. Cardboard consists of a carton box where the smartphone and lenses are inserted through which the human eye can blend the double image of the model displayed on the device screen by enabling an immersive experience.



Figure 98: Stereoscopic render visualization.

Files AR visualization

Markers, like QR Code and Auras, represent two ways to display additional information in AR. The first method is the most common to all sectors and provides for the automatic generation of markers by web applications. While Auras are the visual augmented reality experiences generated by the *Aurasma* application which connect real world image to digital assets like videos, documents and web pages. The steps are the uploading of the trigger image in the *Aurasma* platform and the creation of the Overlay that includes the digital element and the mode to launch it. The Aura needs to be shared to be visualized by the *Aurasma* app. By framing the trigger with the camera of the smartphone or tablet, the content is activated.

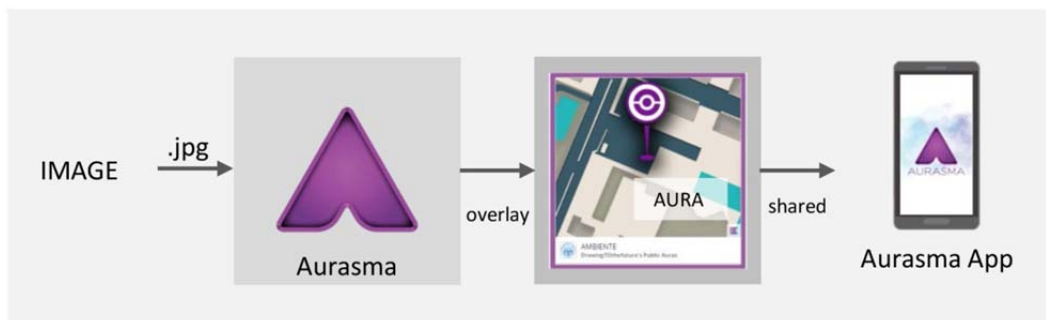

Figure 99: AR process for files visualization.

In this way, many easy-to-use applications are possible, such as:

- link web pages of interest according to the entity;
- provide information on spaces or workstation availability from the space management system;
- make safety information available in every room (e.g. evacuation plan);
- display the As built technical drawings;
- view instructions and maintenance procedures,
- connect worksheets (e.g. *Google docs*) for equipment maintenance check.

An example of AR application in the FM field is provided by the experimental methodology implemented for the management of maintenance activities. As an example, different solutions have been tested within the Pala Alpitour case study using *Aurasma* as a means to link technical data and inspection reports. In the first case, markers are used to identify the different node type of the steel cover described in the previous chapter and to link documents that contain drawings and technical descriptions of components, as well as related maintenance information. The same document is also associated with the fictitious objects represented in the model to have the same information both in the field and in the office. The images refer to the implementation of life line maintenance information. As a first step, the image to be used as a marker was created, then it was uploaded to *Aurasma* to create the Aura. The overlay links the additional content with the image by specifying the display mode. Once the Aura was shared, the marker was placed in the field in correspondence of the life line. By framing the marker with a tablet it is possible to retrieve information required for the maintenance operations, that are immediately available without having to search them, reducing errors and optimizing time.

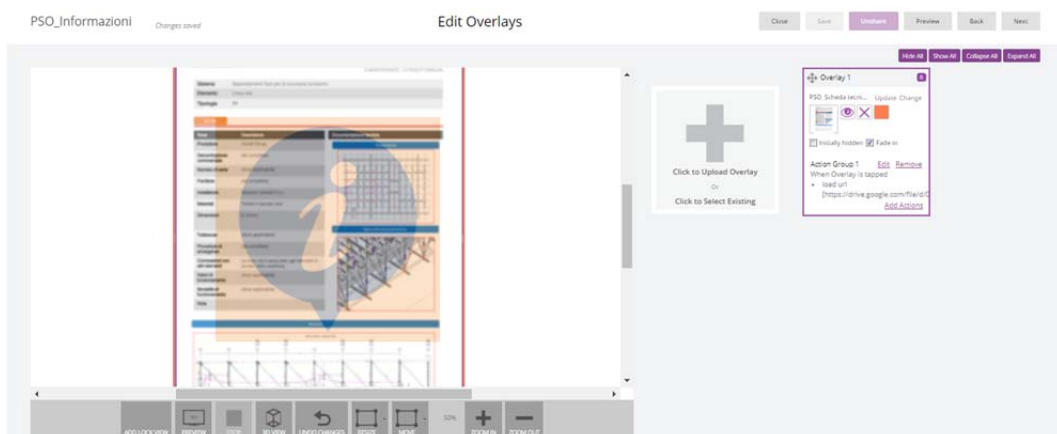

Figure 100: Overlay setting in Aurasma.

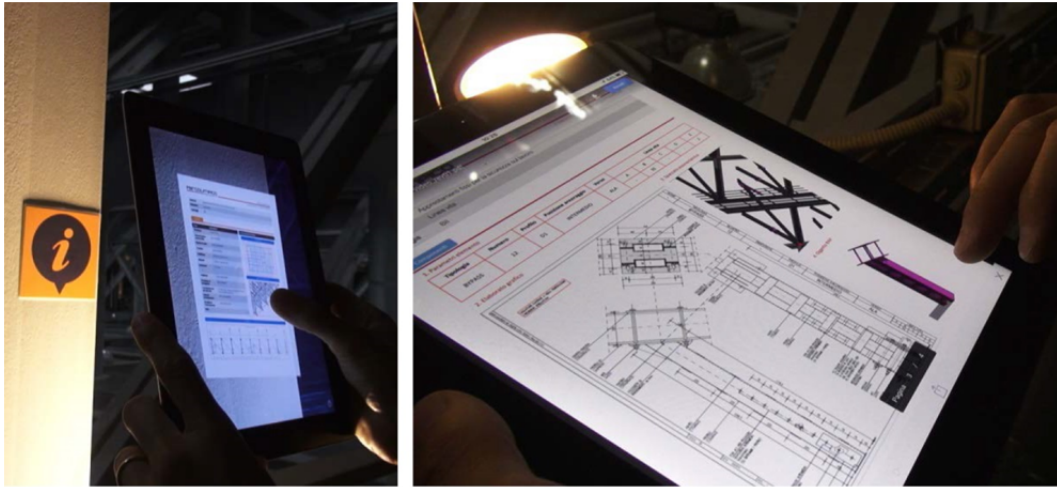

Figure 101: Marker enabling AR technical data visualization.
Case study: Pala Alpitour, Turin.

In the second case, the marker identifies components that are subject to periodic control and maintenance activities such as doors and fire extinguishers. It recalls the maintenance worksheet that certifies the operator's activity and reports the critical problem encountered. This document can be retrieved through the overlay in both editable (e.g. excel, *Google sheets*) and pdf format. In this way, this kind of procedure can be managed in a digital way, overcoming the traditional paper-based approach.

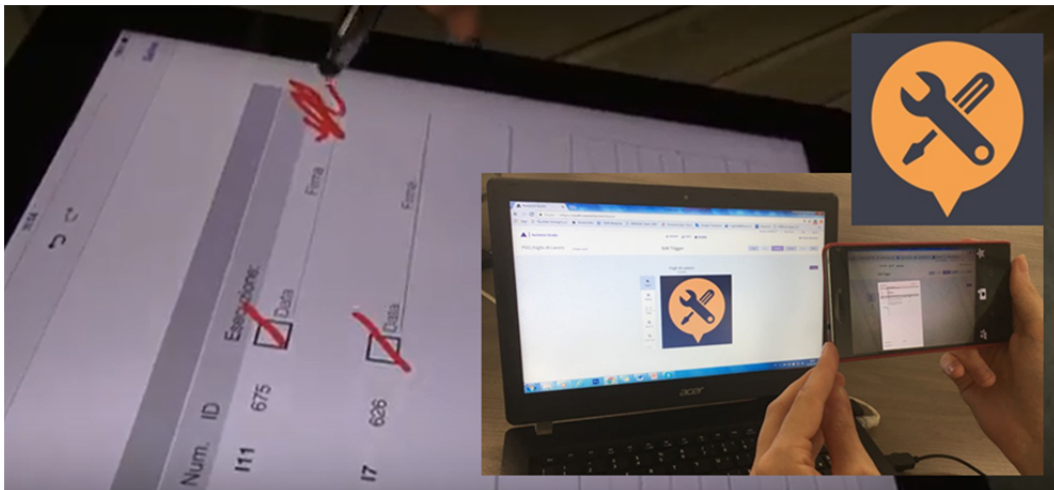

Figure 102: Marker enabling AR maintenance worksheet visualization.
Case study: Pala Alpitour, Turin.

From the methods described so far, two applications have been developed for the communication of city data to citizens, as illustrated in the two sections below.

6.4 The cadastre of the future

The digital progress has become an opportunity for a powerful information revolution also for the architectural sector. In the Smart City perspective, knowledge, organizing, sharing and use of building information are crucial, therefore, the information recorded at the building scale must necessarily be related to the city urban area. This link can be useful to provide an overview of the city for several activities such as territorial planning, management, and energy efficiency assessment. As stated in the previous chapters, BIM models allow us to store dataset of information that can be retrieved and used with different levels of detail depending on users, from the citizen to the building manager, from the energy manager to the city planner. Moreover, the digitalization process is only successful if the information is manageable, so they can be consulted through multiple systems and for different purposes. In fact, it is noted that greater technological means of communication are required to have a substantial urban culture progress (Colletta, 2017). In this scenario, new representation and visualization methods are possible to enable an increasing number of users to easily interact with data. The main idea is to create an Augmented City in which several subjects (individuals, organizations, Public Administration) can add layers of digital information in real-time. The user can access and experience these datasets in multiple ways providing a personal vision of the city. One of these layers can be constituted by BIM models which can be explored through different display technologies. As a preliminary step within this field of research applied at the city level, a map has been developed to establish the collector of information. Hence, the concept is to create a series of touch points from the two-dimensional static representation and use the Augmented Reality to increase the perception of space overlapping the reality. In fact, AR is a visual content management 2.0 that adds new levels of information in real time and with high interaction rate using all types of mobile devices. Currently this type of communication is widely used in the museum and tourist area, to make specific information available on certain objects/points of interest. The City of Turin is the subject of the map, as this study has become the occasion to gather the experience of digitalization of the public buildings of the city launched by the TOBIM project as well as the results of the European DIMMER (District Information Modelling and Management for Energy Reduction) project, focusing on representation and energy saving at district scale. The primary aim of the map is to bring citizens closer to a new information management approach for buildings and cities, based on an intelligent digitalization of the built heritage involving BIM methodology. Augmented and Virtual Reality help to define a new Augmented City model in the era of Smart City. The map presents a challenge for the Real Estate management, based on integrated and dynamic data sharing, always updated and implemented over time. The innovation consists in combining traditional elements of drawing with digital.

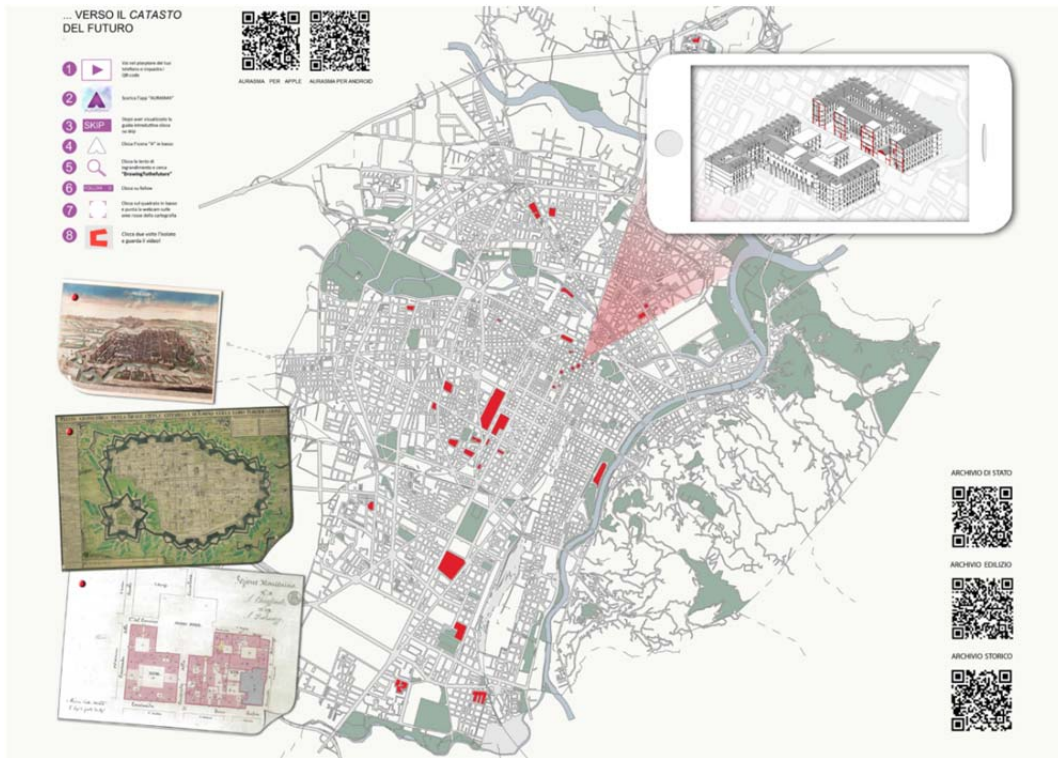

Figure 103: Main idea for the cadastre of the future.



Figure 104: Consultation of the map through Augmented Reality.

Different options of AR and VR visualization modes have been set to establish an interactive relationship with users. In the first case, information about buildings and their contexts such as illustrative video, drawings or web pages are recalled using *Aurasma* application framing the building, acting as a trigger, through a smart device (e.g. tablet, smatphone). In this way, it is possible for example to illustrate the cognitive process of buildings investigation within the TOBIM project or the possible use of this data for management. A partial immersion inside or outside the building and its context has been made possible linking rendered stereoscopic views through QR Code. As an alternative, the BIM models can be explored through web viewers (e.g. *Autodesk A360*) enabling a simple consultation of all the elements and associated data. In this manner, it is possible to spread the knowledge stored in a BIM model uploading it on-line.

Similarly, commercial or ad hoc applications can be recalled to display data differently depending on the purpose. For example, a Fire Safety Management application (Marilungo, 2017) has been included to identify safety information and the escape routes as well as fighting equipment, virtually navigating the BIM model through joysticks. Objects with additional contents become bright when you get closer to them to provide information.

Finally, VR has been exploited using *Oculus Rift* viewers to have a complete immersive navigation of BIM models. This method has been applied to highlight different aspects of the digital representation, such as the overlapping of historical content (Davardoust, 2017), the display of the systems as-built for maintenance, and stage of the progress of a building under construction. Wearing the glasses, the user can have a virtual tour getting in touch with a huge amount of information.

In addition to digital references placed on the map, some buildings have been represented by simplified three-dimensional models created with a 3D printer. This choice further underlines that the digital revolution imposes a representation that immediately recalls the reality and simple but at the same time effective communications tools.

The potential of these applications in relation to the user perception has been evaluated by a survey during the Made Expo 2017. Results show that this means of communication is most effective to inspire users to interact with building data as they exploited a new kind of reality used every day in other contexts. The success is guaranteed by the proper overlap between VR and AR with more traditional methods known by everyone. In fact, 96% of the 150 survey participants described the installation effective/very effective in representing an Augmented City and sets the basis for the Cadastre of the Future.

6.5 Gamification approach for user awareness

The use of BIM models combined with Virtual and Augmented Reality can reach unexpected applications in the communication field including gamification. The experience is part of the EEB project's dissemination activities and pursues the ultimate goal to share research developments in an eye-catching way for users. The need of spreading knowledge is related to the engagement of common users in efficiency processes to stimulate them to change their behavior towards sustainability. The gamification approach helps us to achieve this objective because it envisages the use of video game design elements in non-games contexts (Deterding, Dixon, Khaled, & Nacke, 2011). Specifically, an interactive BIM-based map, has been created to stimulate children's knowledge of the heritage and the learning of smart cities strategies through the use of innovative means of communication and interaction, such as VR and AR. In fact, active and game-based learning represents a strategic method to dealing with complex topics in a more interesting and entertaining manner resulting in user awareness. The *3D BIM Map* represents the Settimo Torinese urban area, as the demonstrator of the research project, in which the case studies are outlined as well as other points of interest, on the basis of which the game takes place. The map layout includes a simplified representation of buildings, roads, parks and squares in order to collect all the urban environments which may be subject to efficiency measures. Adopting the same approach described in the previous section, the purpose is to explore virtually the city and learn notions by questioning the focal points distributed on the map. The game consists of different steps with the goal to explore the key concepts of how to realize a Smart City, giving children the chance to suggest their innovative proposals on the basis of what they have learned. It is a role-playing game where the winner is the team that earns a higher number of points by answering questions correctly and making the most innovative ideas at the final stage. Players are divided into 6 teams according to the smart city axes: Environment, Energy, Renewable Sources, Mobility, Internet of Things (IoT) and Sustainability. Each team has a robot as a distinctive symbol, inspired by the robotics theme of the Settimo Torinese 2017 Festival of Science, one of the events in which the game was presented. The game characters are also illustrated through cards that explain the main concepts associated to the topic and some practical applications. Each task of the game corresponds to specific concepts and considerations within a guided learning path: (1) the knowledge of the investigation context is essential to identify the possible areas of intervention, (2) smart city strategies can be combined together to promote innovative powerful solutions, (3) making the positive experience system. Tools and technologies used to get the individual objectives have been selected from previous game experiences within the SEEMPubS and DIMMER projects (Semeraro, Ugliotti, Osello, Del Giudice, & Rapetti, 2016; Osello, et al., 2015).



Figure 106: 3D BIM Map.
EEB Project.

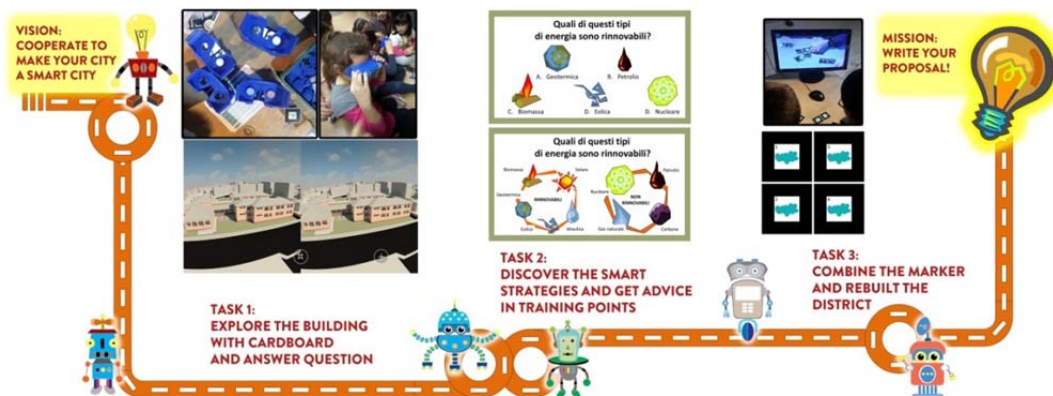

Figure 107: Tasks of the EEB 3D BIM Map.

In the first task children can experience VR through the use of customized cardboard, made with the 3D printer, to visualize the three dimensional models of the EEB case studies and their surroundings. These buildings include a primary and a secondary school and the central library of the city. By framing the correspondent QR Code and putting the smartphone in the viewer, their immersive vision is enabled through a stereoscopic rendered view generated by *Autodesk 360* cloud platform. BIM models are the crucial element of this task: children should carefully observe them and answer 10 questions regarding their characteristics such as shape, building type, enclosure, floor number as well as surrounding built-up areas and urban spaces. As output, players learn to observe the urban context, understanding that there are several fields of application of smart strategies besides buildings, considering for example green areas, squares and streets, up to consider the entire city.



Figure 108: Immersive vision through cardboard.

In the second task, smart city strategies are investigated through a quiz. Questions are displayed in AR on tablet or smartphone with the use of *Aurasma* application by framing the training points on the map. Clicking on the device screen at the correct answer, the solution and a brief suggestion for sustainability are displayed.



Figure 109: Interaction with the map through AR.

Finally, the last task allows children to experience Augmented Reality. It is inspired by the DIMMER game and consists of composing a jigsaw corresponding to the district of each case study. The jig saw puzzle is composed by 9 pieces and must be solved using AR. Framing the pieces with the camera, virtual portions of the district are displayed on the computer monitor and children need to correctly assembled them together to recompose the neighbourhood. The starting points for the creation of the pieces are the BIM models of the case study and their urban context. As described in the previous section, the model needs to be exported through .FBX in *Autodesk 3DS Max* to allow the AR visualization through the AR-media plug-in. Colours has been set to suggest the matching of the pieces.

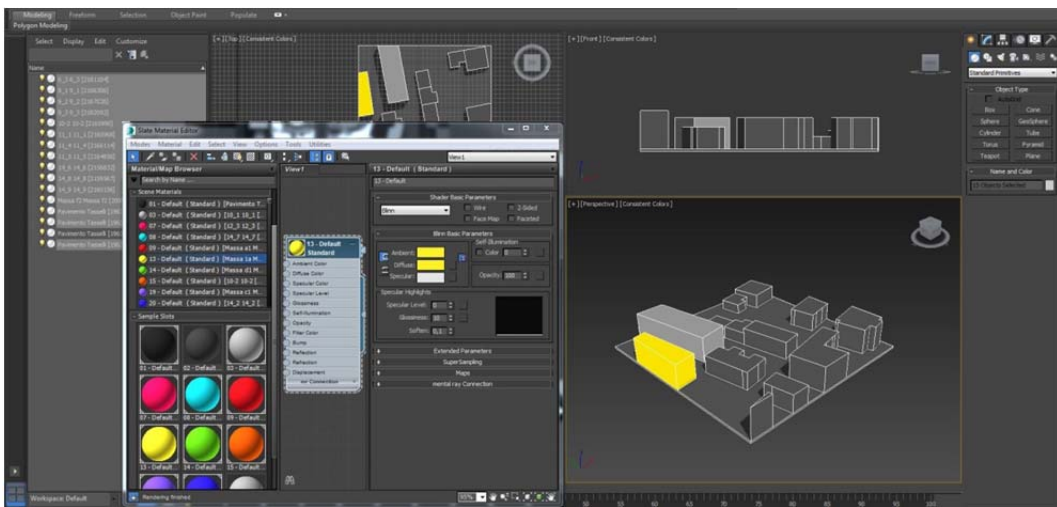

Figure 110: Color setting on Autodesk 3DS Max.

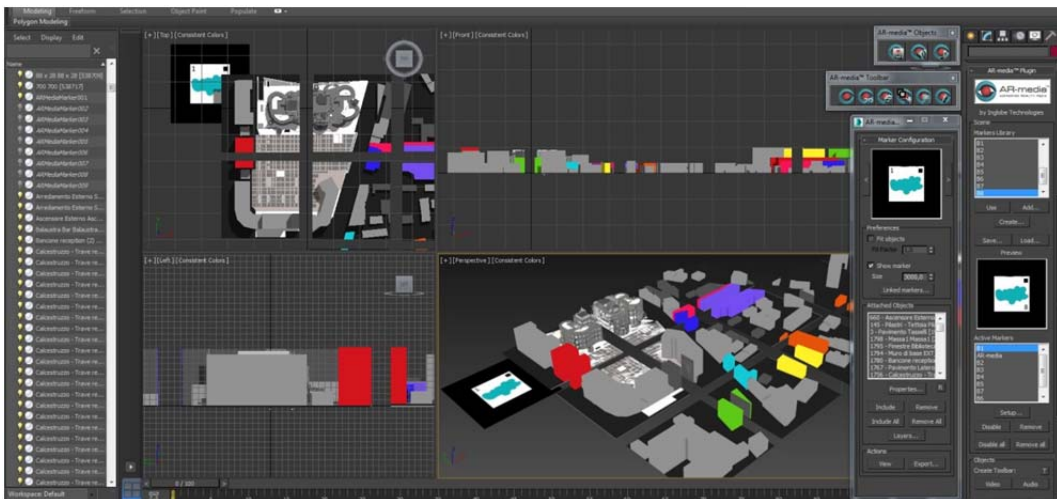

Figure 111: Marker setting through the AR-media plug-in.

Then, the model object belonging to the same pieces has been associated with a marker to display it in AR. A project containing all the districts pieces has been set in order to display them individually or all together by expanding the city's vision and increasing the difficulty of the game. Compare to traditional jig saw, the user does not have previous experiences so imagination and eye-hand coordination is more relevant than memory. The games showed that youngest children are more skillful compared to adults; they were faster in combining the puzzle of markers, because they are more used to playing using creativity. Within the smart city, the jig saw means that people need to work and cooperate together in order to create something new for a more efficient city and making the system the positive experiences.



Figure 112: AR jig saw puzzle.

All these tasks give points, but it is possible to win an extra bonus by giving the most creative solutions and ideas to make the city smarter. This way, children are led to think that something can improve everyday life, using technology offered by the Internet of Things as well as virtuous and sustainable actions and behaviour. This kind of approach promotes children's interest and a proactive learning process as they feel directly involved in the game. As a result, several proposals aimed at the transformation of the Settimo Torinese city into a smart city have been expressed by children. The analysis of these suggestions (De Luca, Del Giudice, Dellosta, Fonsati, Osello, & Ugliotti, 2017) is significantly interesting, because it is a way to "see things from children's point of view" and to understand their level of knowledge on sustainability and energy efficiency issues, as well as their awareness towards what a "sustainable behaviour" means. These creative solutions have been the most interesting to analyse, because they show the children's ability to use imagination in order to solve real problems most of the time unexpectedly, showing a great attention in exploiting new technologies, even if through surrealistic proposals.

From an educational point of view, the EEB 3D BIM Map helps children both to emphasize the importance and effectiveness of the strategies traditionally used and to encourage the application of new technologies to achieve the targets of a smart city.

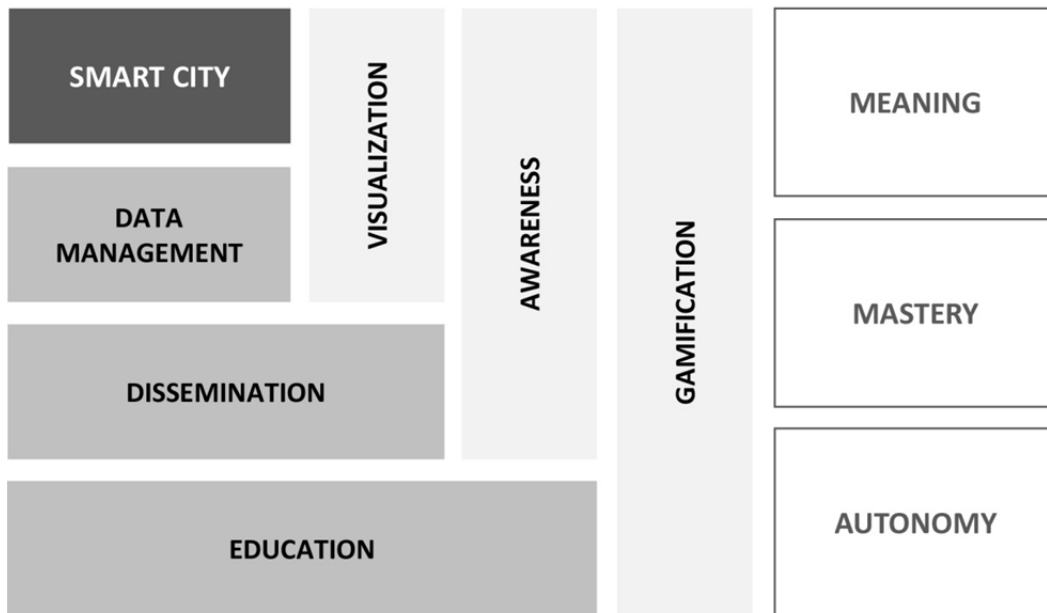

Figure 113: Tetris of smart city concept toward gamification approach.

Source: (De Luca, Del Giudice, Dellosta, Fonsati, Osello, & Ugliotti, 2017)

By adopting a gamification approach, the user awareness framework is complete, also including education. As the young generation will be the “society of the future” the game engages children to have an active part in the development of a smart city. The typical aspect of gamification has been achieved by transmitting knowledge on specific topics through ICT (Meaning) and involving children in fun activities in which they can contribute actively (Mastery). Depending on the age or the level of instruction of the player suggestions can be necessary but the task give the time to reflect and to understand potential mistakes (Autonomy).

Results

In this study, the challenges and the importance of BIM for Facility Management have been highlighted. The proposed articulation of the investigation underlines the synergy between the aspects of organization, usage, and visualization of building data for smart information management. As emphasized several times, the primary purpose of BIM is to bring efficiency and costs saving introducing Lean production thinking in the construction industry and establishing collaborative processes. Its major achievement lies not so much in the realization of a digital model as in extracting its maximum potential to manage the building life cycle. Consequently, the quality of data and the accuracy of modelling are central to establishing an effective BIM-based knowledge system. Certainly the model must be created to satisfy the individual users needs but it is necessary to adopt a broader perspective to provide functional and manageable outputs. Understanding the added-value of BIM within management activities can be the driver for change overcoming the current critical practices of the handover stage. However, as well documented throughout the case studies, BIM is also crucial to the built heritage management. The research findings suggest that efficient data management through BIM could provide a structured framework to improve asset handover and maintenance. Following definitions provided in the methodology, the study gives a great contribution to understand how to realize a FM BIM model depending on its purpose and the stage of the process in which it is made. In fact, contrary to what is commonly thought, setting up a FM BIM model does not necessarily mean to build an As built model. For existing buildings, it is not convenient to try to reach the detail and complexity of an As built model, in addition to the fact that it would be impossible for the lack of data that characterizes the current asset management. While it is essential to understand the information to be included in the model to manage processes according to objectives. Often not carefully modelled, spaces are the key entity around which all FM services turn, enabling the relationship between the model components and the spatial dimension. Furthermore, a correct space mapping introduces a valuable source to derive performance metrics and indicators of quantity, costs of buildings. LODs are taken into account to establish a common language, however the highest level of detail is not the only possibility for FM but also a simplified representation of objects with associated metadata can be useful. The model must

be created in such a way as to guarantee its updating and possible integrations over time, thus calibrating the level of information entered. The use of interoperable systems and standards is crucial for data continuity across the lifecycle. Therefore the development of FM BIM model needs to be conceived from the beginning for data sharing both between users and applications, reaching level 2 of maturity. As pointed out above, BIM data intercepts most of the needs of Facility Management services and it can be used directly, or through interoperability and data integration processes. The test conducted under this study shows the variety of the application fields in which BIM models can be used to optimize data workflow. The integrated approach can significantly increase the knowledge of buildings improving management and monitoring tools. However, at present it is not possible to have a unique BIM model for all purposes described, but it is necessary to introduce simplifications, or additional work is required to make the simulations run. Results are summarized in the following table showing the current strengths and weaknesses. The main problem lies in the information transfer through the exchange formats. Geometry is almost always maintained, but some properties are not transferred, so it is necessary to re-insert the data manually. Further research is needed for a fully utilization of BIM, especially in the energy field. Although the interoperability process is still not perfect, the benefits are much more relevant to change the way. In addition to specialist simulation, great importance has been given to data visualization to facilitate the work of both operators and managers. AR and VR can provide state-of-the-art solutions to reduce the complexity of maintenance operations as well as make information available at the right place at the right time. Moreover, users engagement through most effective communication methods is a central element to disseminate information and to foster actions for a smart asset management. The use of innovative digital tools that have become part of everyday life stimulates interaction with information from buildings and cities end-users, who can become an active part in the building process. Lastly, in parallel to the BIM models creation, it is essential to plan a process of maintenance through a dedicated structure that must receive information from all those who act in various ways on the building through a defined procedural flow.

Table 12: Summary of the interoperability tests and exchange formats.

Purposes	Software	Exchange format	Benefits	Critical issue	Changes to the model
Space management	Archibus	Smart Client Extension	FM system automatic population. Floorplans usability and space reporting. Web user-friendly interface.	Big Revit files. Large real estate portfolios models management.	Not necessary.
Energy simulation	Edilclima	EC770 plug-in .E00	Processing time optimization. Accuracy of the simulation. Geometry better control. Revit support for windows and shading calculation.	No thermal data acquisition. Inadequate graphical interface.	Elimination of not useful elements for the calculation.
CFD simulation	Pathfinder	.FBX	Processing time optimization. Accuracy of the simulation Geometry import.	No materials recognition.	Not necessary.
AR visualization	AR-media	.FBX	Effective communication.	No materials recognition.	Kept only the object to display.
VR visualization	Unity	.FBX	Effective communication.	No materials recognition.	Kept only the object to display.
3D printing	Cura	.STL	Concrete representation.	Subdivision of model if larger than the printing plate.	Elimination of too small objects. Simplification of complex geometry.
ODBC database	Microsoft Access	Revit BLink plug-in	BIM model database usage.	Table structure complexity.	Not necessary.

Conclusion

In order to meet the demands on efficiency and sustainability of smart cities as well as the new technological and social challenges and regulations, overall review of the construction industry needs to be implemented. In this framework, BIM is certainly the key point for the sector digitalisation, but a management strategy is required for a constructive contribution. To revitalize the construction industry, it is necessary to “reverse the cycle” in the sense of introducing the management experience in design and construction phases to set up BIM models effectively exploited. In this way, interoperability is pursued not only at the technological (software) and organizational (people) levels, but by setting an integrated process through the enrichment of management technical knowledge and practices. According to this vision, the concept of Building Information Modelling extends and strengthens its meaning in BIM Management.

BIM Management - Transversal procedural methodology that aims to guarantee the BIM process effectiveness. It is understood not only as an integrated process leading to management but as a process that reflects the management experience and allows us to set the facility management services from the correct setting of the digital model.



Figure 114: BIM management approach.

Operations and maintenance are the main triggers that increase the total lifecycle cost, so they need powerful tools to enhance accessibility and cut down the time of retrieval of the data. Combining the potential of BIM methodology with the relevance of Facility Management, quality, speed and efficiency involve a reduction in knowledge-related process costs as well as the optimization of management solutions. The issue of sustainability is pursued in economic terms: a

better management and control of a building allows to obtain considerable savings that can be reinvested in order to generate more benefits for companies, users and for the environment. By adopting this approach, the general objective is to start from the buildings management optimization then enlarge the scale to the district, up to rule the entire city.

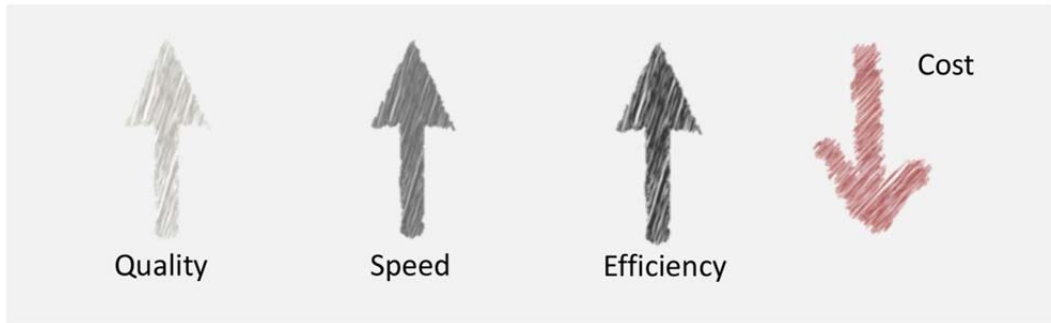

Figure 115: Potential of BIM correctly involving FM.

References

- AEC UK. (2015). *AEC (UK) BIM Technology Protocol. Practical implementation of BIM for the UK Architectural, Engineering and Construction (AEC) industry.*
- Alashwal, A., & Hamzah, A.-R. (2014). Developing a conceptual framework of fragmentation in construction.
- Ali Khan, R., Liew, M., & Ghazali, Z. (2014). Malaysian Construction Sector and Malaysia Vision 2020: Developed Nation Status. *Procedia - Social and Behavioral Sciences* 109:507-513.
- Allied Analytics LLP. (2016). *World Building Information Modeling (BIM) Market – Opportunities and Forecasts, 2015-2022.*
- Amaro, G., Raimondo, A., Erba, D., & Ugliotti, F. (2017). A BIM-based approach supporting Fire Engineering. In E. Nigro, & A. Bilotta (Ed.), *IFireSS 2017, 2nd International Fire Safety Symposium. Conference: IFireSS - International Fire Safety Symposium, June 7-9, 2017*, pp. 137-144. Naples, Italy: Doppiavoce.
- Amaro, G., Raimondo, A., Erba, D., & Ugliotti, F. (2017). Il BIM per il Fire Engineering e per il Safety Management. *INGEGNO, Gennaio 2017*, 5, 51.
- Anafyo. (2015). *Il BIM in Italia: un quadro della situazione.*
- Archibus. (2008). *Overlay with Design Management for AutoCAD® & Revit®.* . Tratto il giorno 09 25, 2015 da Archibus: http://archibus.com/index.cfm/pages.document/template_id/562/
- areo blog. (2017). *BIM Levels and Asset Information Management.* Tratto il giorno 05 2017, 20 da <http://blog.areo.io/bim-levels-and-asset-information-management/>

- Autodesk Knowledge Network. (2017, 07 12). *About Schedules*. Retrieved 07 15, 2017, from Autodesk Knowledge Network: <https://knowledge.autodesk.com/support/revit-products/learn-explore/caas/CloudHelp/cloudhelp/2018/ENU/Revit-DocumentPresent/files/GUID-73090B70-8A13-4E12-909C-F25D724D5BA7-htm.html>
- Autodesk Support. (2014, 11 01). Retrieved 03 2017, 18, from Autodesk Knowledge Network: <https://knowledge.autodesk.com/support/revit-products/learn-explore/caas/sfdarticles/sfdarticles/Best-practices-for-template-creation.html>
- Azuma, R. T. (1997). A Survey of Augmented Realit. *Teleoperators and Virtual Environments* 6, 355-385.
- Barone, L. (2014). BIM for Energy Modelling. Case study: Palazzo LL.PP., Torino. *Master Thesis in Building Engineering, Politecnico di Torino*.
- Bayar, M., Aziz, Z., Tezel, A., & Arayici, Y. (2016). Optimizing handover of as-built data using BIM for highways.
- BCG. (2016). *Digital in Engineering and Construction: the transformative power of Building Information Modelling*.
- BIFM. (2012). *This lack is accentuated in the case of existing buildings*. Hertfordshire, UK: British Institute of Facilities Management.
- BIM Forum. (2016). *2016 LOD Specification*.
- BIM Task Group. (2012). *The Government Soft Landings Policy*. Retrieved from BIM Task Group: <http://www.bimtaskgroup.org/gls-policy-2>
- BIM Task Group. (2015). *BIM Frequently Asked Questions*.
- BIMFORUM. (2015). *Level of Development Specification 2015*.
- BIMFORUM. (2016). *LOD*. Tratto il giorno 02 12, 2017 da BIMFORUM: <http://bimforum.org/lod/>

-
- Bocconcino, M. M., Del Giudice, M., & Fabio, M. (2016). *Disegno e l'Ingegnere - Il Disegno e la Produzione Edilizia tra tradizione e innovazione*. Torino: Levrotto & Bella.
- Bottaccioli, L., Aliberti, A., Ugliotti, F., Osello, A., Macii, E., Patti, E., et al. (2017). Building energy modelling and monitoring by integration of IoT devices and Building Information Models. *Building Digital Autonomy for a Sustainable World (COMPSAC)*, (p. 9). Torino.
- British Standards Institution. (2007). *BS 1192: 2007 Collaborative production of architectural, engineering and construction information – Code of Practice*.
- British Standards Institution. (2013). *PAS 1192-2:2013 Specification for information management for the capital/delivery phase of construction projects using building information modelling*.
- BSI. (2013). *PAS 1192-2:2013 Specification for information management for the capital/delivery phase of construction projects using building information modelling*.
- Building Owners and Managers Association. (2010). *ANSI/BOMA Z65.1—2010: Office Buildings: Standard Methods of Measurement*.
- Carmigniani, J., & Borko, F. (2011). Augmented Reality: An Overview. In F. Borko, *Handbook of Augmented Reality*. Springer.
- Chelleri, L., & Olazabal, M. (2012). *Multidisciplinary perspectives on urban resilience. Workshop Report. 1st edition*. Bilbao, Spain: BC3, Basque Centre for Climate Change.
- Ciribini, A. L. (2013). *L'information modeling e il settore delle costruzioni: IIM e BIM*. Maggioli Editore.
- Colletta, T. (2017). *6.Città storiche e conoscenza urbana. L'innovazione tecnologica per la diffusione della conoscenza urbana. Le possibili applicazioni. I musei della città*. Tratto il giorno 05 2017, 13 da Federica Web Learning Università degli Studi di Napoli Federico II: <http://www.federica.unina.it/architettura/storia-urbanistica-contemporanea/innovazione-tecnologica-diffusione-conoscenza-urbana/>

- Construction Specification Institute. (n.d.). *Uniformat*. Retrieved 05 05, 2016, from CSI Building Knowledge Improving Project Delivery: <http://www.csinet.org>
- CRESME. (2016). *XXIV Rapporto congiunturale e previsionale CRESME. Il mercato delle costruzioni 2017*.
- Dalmaso, D., & Ugliotti, F. M. (2015). L'utilizzo della AR per il FM. In A. Osello, *Building Information Modelling, Geographic Information System, Augmented Reality per il Facility Management* (p. 300, 278-285). Palermo: Dario Flaccovio Editore.
- Davardoust, S. (2017). The BIM process for the architectural heritage: New communication tools based on AR/VR Case study: Palazzo di Città. *Doctoral Dissertation, Politecnico di Torino*.
- Davtalaba, O., & Delgadob, J. (2014). Benefits of 6D BIM for Facilities Management Departments for Construction Projects – A Case Study Approach. ISARC2014.
- De Luca, D., Del Giudice, M., Dellosta, M., Fonsati, A., Osello, A., & Ugliotti, F. (2017). Augmented and virtual reality for smart cities users' awareness. *11th International Technology, Education and Development Conference*, (p. 4333-4342). Valencia.
- Deterding, S., Dixon, D., Khaled, R., & Nacke, L. (2011). From game design elements to gamefulness: defining "gamification". *MindTrek '11 Proceedings of the 15th International Academic MindTrek Conference: Envisioning Future Media Environments* (p. 9-15). Tampere, Finland: ACM.
- Di Giuda, G. M., Villa, V., Eastman, C., Teicholz, P., & Rafael, S. (2016). *Il BIM Guida completa al Building Information Modeling*. HOEPLI.
- East, W., & Brodt, W. (2007). BIM for Construction Handover. *Journal of Building Information Modeling*, 28-35.
- Eastman, C., Teicholz, P., Sacks, R., & Liston, K. (2011). *BIM Handbook: A Guide to Building Information Modeling for Owners, Managers, Designers, Engineers and Contractors, 2nd Edition*. John Wiley & Sons.

-
- Erba, D., Osello, A., Semeraro, F., & Ugliotti, F. (2015). *Quando Perchè e Come usare il BIM per il Facility Management in Italia. Report developed as part of a research promoted by Systema S.r.l. and Autodesk Inc.*
- EU BIM Task Group. (2017). *Handbook for the introduction of Building Information Modelling by the European Public Sector.*
- European Climate Foundation. (s.d.). *Roadmap 2050*. Tratto il giorno 11 11, 2016 da Roadmap 2050: <http://www.roadmap2050.eu/>
- European Commission. (2012, 04 20). *Communication from the Commission to the European Parliament, the Council, the European Economic and Social Committee and the Committee of the Regions: A strategy for e-procurement (COM(2012) 179 final).*
- European Commission. (2013). *Energy-Efficient Buildings Multi-annual roadmap for the contractual PPP under Horizon 2020*. Luxembourg: Publications Office of the European Union.
- European Commission. (n.d.). *HORIZON 2020*. Retrieved 08 04, 2016, from European Commission: <http://ec.europa.eu/programmes/horizon2020/>
- European Commission, D. G. (2011). *Cities of tomorrow - Challenges, visions, ways forward*. Luxembourg: Publications Office of the European Union.
- European Parliament. (2014). *Directive 2014/24/EU of the European Parliament and of the Council of 26 February 2014 on public procurement and repealing Directive 2004/18/EC*. Retrieved from EUR-Lex: <http://eur-lex.europa.eu/legal-content/en/ALL/?uri=CELEX:32014L0024>
- European Parliament. (2014). *Mapping Smart City in the EU*. Tratto da <http://www.smartcities.at/assets/Publikationen/Weitere-Publikationen-zum-Thema/mappingsmartcities.pdf>
- European Parliament, & Council of European Union. (2002, 12 16). *Directive 2002/91/EC of the European Parliament and of the Council of 16 December 2002 on the energy performance of buildings*. Tratto da <http://eur-lex.europa.eu/eli/dir/2002/91/oj>
- Facility Management Magazine. (2015). TOP Trends for AECO Industry in 2016. *Facility Management Magazine*.

- FIEC. (2017). *Making BIM a Global Success*. Brussels.
- FIEC, & European Commission. (2017). *FIEC Annual Report 2017*.
- General Services Administration. (2007). *Building Information Modeling Guide Series 01 – Overview*. Tratto da https://www.gsa.gov/graphics/pbs/GSA_BIM_Guide_v0_60_Series01_Overview_05_14_07.pdf
- Gu, N., & London, K. (2010). Understanding and facilitating BIM adoption in the AEC industry. *Automation in Construction, Volume 19, Issue 8*, 988-999.
- Hardin, B. (2009). *BIM and Construction Management: Proven Tools, Methods, and Workflows*. Indianapolis: Wiley.
- IBM Corporation. (s.d.). *Infrastructure. Operations. People.* . Tratto il giorno 10 14, 2015 da IBM: http://www.ibm.com/smarterplanet/ie/en/smarter_cities/overview/
- IBM Corporator, & IBM Corporation. (2011). *IBM TRIRIGA: The power of true integration in workplace management solutions*. Tratto il giorno 10 20, 2015 da http://www.groupecreatech.com/images/IBM_Tririga.pdf
- IFMA, & IFMA Foundation. (2013). *BIM for Facility Managers*. United States of America: Paul Teicholz.
- InfoComm International. (2011). *Building Information Modeling (BIM) Guide*. Tratto il giorno 10 02, 2015 da <http://www.infocomm.org/cps/rde/xchg/infocomm/hs.xsl/32957.htm>
- International Facility Management Association. (2013). *BIM for Facility Managers*. United States of America: Wiley.
- ISO/IEC JTC 1. (2014). *Smart cities. Preliminary Report 2014*.
- Karlshøj. (2014). *BIM – A tool for an effective and sustainable facility management process* . Tratto da <http://iug.buildingsmart.org/resources/itm-and-iug-meetings-2014-stockholm/conference/building/bim-2013-a-tool-for-an-effective>

-
- Kincaid, D. (2002). *Adapting Buildings for Changing Uses: Guidelines for Change of Use Refurbishment*. New York: Spon Press.
- Lee, S., An, H., & Yu, J. (2012). An Extension of Technology Acceptance Model for BIM-Based FM. *Construction Research Congress*, (p. 602-611).
- Malleson, A. (2016). *BIM Survey: Summary of findings*. UK: NBS.
- Marcos Guinea, A., & SYSTEMA. (2016, 09 20). BIM come supporto alla progettazione integrata. *INFOBUILD*.
- Marilungo, M. (2017). As built BIM modeling applied to Virtual Reality. Case study of Piemonte Region's Skyscraper. *Master Thesis in Building Engineering, Politecnico di Torino*.
- McGraw Hill Construction. (2007). *Interoperability in the Construction Industry*. McGraw Hill Construction.
- McGraw Hill Construction. (2014). *The business value of BIM for construction in major global markets: how contractors around the world are driving innovation with Building Information Modeling*. McGraw Hill Construction.
- Milgram, P., Takemura, H., Utsumi, A., & Kishino, F. (1995). Augmented reality: a class of displays on the reality-virtuality continuum. *Proc. SPIE 2351, Telem manipulator and Telepresence Technologies* (p. 11). Hari Das.
- Ministero dell'Interno. (2015, 08 03). Approvazione di norme tecniche di prevenzione incendi, ai sensi dell'articolo 15 del decreto legislativo 8 marzo 2006, n. 139. Italy.
- Ministro dell'Interno. (2007, 05 09). Direttive per l'attuazione dell'approccio ingegneristico alla sicurezza antincendio/Guidelines for the implementation of the engineering approach to fire safety. Italy.
- Moglia, G., Ugliotti, F., Dellosta, M., & Osello, A. (2016). Virtual and Augmented Reality for citizen involvement in the evaluation of the urban transformation. In S. Bertocci, & M. Bini (Ed.), *Le ragioni del disegno. The reasons of drawing. Pensiero, forma e modello nella gestione della complessità. Thought, shape and model in the complexity management. Conference: XXXVIII International Meeting of Teachers of*

Representation Disciplines, The Reasons of Drawing, September 14-16, 2016, pp. 4, 1197-1200. Gangemi Editore spa.

- Mohd Nawi, M., Nazim, B., & Bahauddin, A. (2014). Impact of Fragmentation Issue in Construction Industry: An Overview. *MATEC Web of Conferences 15*.
- N. 01210/2017, N. 02469/2016 (Tribunale Amministrativo Regionale per la Lombardia 05 29, 2017).
- Naghshbandi, N. (2016). BIM for Facility Management: Challenges and Research Gaps. *Civil Engineering Journal*.
- National Institute of Building Science, & buildingSMARTalliance. (2007). *National Building Information Modeling Standard. Version 1 - Part 1: Overview, Principles, and Methodologies*. United States.
- National Institute of Building Sciences. (2016). *ABOUT THE NATIONAL BIM STANDARD-UNITED STATES®*. Tratto il giorno 05 11, 2017 da National Institute of Building Sciences: <https://www.nationalbimstandard.org/about>
- National Institute of Building Sciences, & buildingSMARTalliance. (2015). *National BIM Standard-United States ®*. Tratto da https://www.nationalbimstandard.org/files/NBIMS-US_FactSheet_2015.pdf
- NBS. (2014, 11 01). *BIM Levels explained*. Tratto il giorno 04 18, 2017 da <https://www.thenbs.com/knowledge/bim-levels-explained>
- NBS. (2016). *National BIM Report 2016*.
- NIST. (2004). *Cost Analysis of Inadequate Interoperability in the U.S Capital Facilities Industry*. Tratto da www.nist.gov/manuscript-publication-search.cfm?pub_id=101287
- Osello, A. (2015). *Building information modelling. Geographic information system. Augmented reality per il facility management*. Palermo: Dario Flaccovio Editore.

-
- Osello, A., & Ugliotti, F. (2017). *BIM: verso Il catasto del futuro. Conoscere, digitalizzare, condividere. Il caso studio della Città di Torino*. (A. Osello, & F. Ugliotti, Eds.) Roma, Italy: Gangemi Editore spa.
- Osello, A., Barone, L., Davardoust, S., De Luca, D., Del Giudice, M., Dellosta, M., et al. (2016). The Centrality of Representation with BIM/La Centralità della Rappresentazione con il BIM. *DISEGNARECON, Vol 9, No 16 (2016)*, 12.
- Osello, A., Del Giudice, M., Marcos Guinea, A., Rapetti, N., Ronzino, A., Ugliotti, F., et al. (2015). Augmented Reality and gamification approach within the DIMMER Project. *INTED2015 Proceedings* (p. 8, 2707-2714). Madrid, Spain.: IATED Digital Library.
- Osello, A., Ugliotti, F., Semeraro, F., & SYSTEMA. (2016, 05 18). *Il BIM orientato al Facility Management. Nuove opportunità di gestione del patrimonio edilizio nell'era della transizione digitale*. Retrieved from INFOBUILT: <http://www.infobuild.it/approfondimenti/bim-orientato-facility-management/>
- Phang, T. (2017, 04 03). *Beyond BIM: What's next for the industry?* Tratto il giorno 06 06, 2017 da Construction Global: <http://www.constructionglobal.com/equipment-and-it/beyond-bim-whats-next-industry>
- Poirier, E., Forgues, D., & Staub-French, S. (2014). Dimensions of Interoperability in the AEC Industry. *Construction Research Congress 2014*.
- Ratti, C. (2014). *Architettura Open Source. Verso una progettazione aperta*. Torino: Giulio Einaudi Editore.
- Repubblica Italiana. (2008). Decreto Legislativo 81/08, Art. 91 and Allegato XVI.
- Repubblica Italiana. (2016). *Decreto Legislativo 18 aprile 2016, n.50 Codice dei Contratti Pubblici*.
- ResilientCity. (s.d.). *Resilience*. Tratto il giorno 04 2016 da ResilientCity.org: <http://www.resilientcity.org/>

- Rizzarda, C. (2015, 10 22). *Level of Development: cosa, quando e come?* Tratto il giorno 04 13, 2017 da LinkedIn: <https://www.linkedin.com/pulse/level-development-cosa-quando-e-come-chiara-c-rizzarda?trk=mp-reader-card>
- Rizzarda, C., & Gallo, G. (2017). *La sfida del BIM. Un percorso di adozione per progettisti e imprese*. Milano: Tecniche Nuove.
- Rogers, J., Chong, H.-Y., Preece, C., Lim, C., & Jayasena, H. (2015). *BIM Development and Trends in Developing Countries: Case Studies*. Bentham eBooks.
- Samorì, C. (2017, 04 27). *BIM Summit 2017, Bellicini: Tra vent' anni il settore delle costruzioni sarà diverso, il BIM tra i protagonisti del cambiamento*. Tratto il giorno 05 03, 2017 da Ingegno: http://www.ingegno-web.it/Articolo/5148/BIM_Summit_2017__Bellicini:_Tra_vent__anni_il_settore_delle_costruzioni_sara_diverso__il_BIM_tra_i_protagonisti_del_cambiamento.html
- Santangelo, M., Aru, S., & Pollio, A. (2013). *Smart City. Ibridazioni, innovazioni e inerzie nelle città contemporanee*. Città di Castello (PG): Carocci Editore pressonline.
- Semeraro, F., Ugliotti, F., Osello, A., Del Giudice, M., & Rapetti, N. (2016). The DIMMER project user awareness: Innovative Gamification approach through Augmented Reality. *EDULEARN16 Proceedings* (p. 9, 5104-5112). Barcelona, Spain: IATED Academy.
- Simeone, D., Cursi, S., Toldo, I., & Carrara, G. (2014). B(H)IM -Built Heritage Information Modelling. *Proceedings of the 30th International Conference on Education and research in Computer Aided Architectural Design in Europe, Digital Physicality*, (pp. 613-622).
- Spedding, A., & Holmes, R. (1994). *CIOB Handbook of Facilities Management*. Harlow: Longman Scientific & Technical.
- Stefani, M. (2017, 03 21). I LOD nella UNI 11337:2017. *Ingegno*.
- Talamo, C. (2014). La gestione integrata delle informazioni nei processi manutentivi. Dall'anagrafica degli edifici ai sistemi BIM. *TECHNE 08/2014*.

-
- Talamo, C., & Bonanomi, M. (2015). *Knowledge Management and Information Tools for Building Maintenance and Facility Management*. Springer International Publishing.
- Teicholz, P. (2013). *BIM for Facility Managers*. New Jersey, US: John Wiley & Sons.
- The American Institute of Architects. (2013). *AIA Contract Document*. Tratto il giorno 05 05, 2016 da G202-2013 Project BIM Protocol: <https://www.aiacontracts.org/contract-documents/19016-project-bim-protocol>
- The British Standards Institution. (2014). PAS 180:2014. *Smart cities – Vocabulary*.
- Tietoa, F., & Rajala, M. (2012). *COBIM Common BIM Requirements 2012. Series 2. Modeling of the starting situation*.
- Tonon, D. (2015). Interoperabilità modelli BIM per le simulazioni energetiche negli edifici storici. Caso studio: Piazza Palazzo di Città 7. *Master Thesis in Building Engineering, Politecnico di Torino*.
- Torabi Moghadam, S., Lombardi, P., Ugliotti, F., Osello, A., & Mutani, G. (2016). BIM-GIS Modelling for Sustainable Urban Development. *SBE16 Towards Post-Carbon Cities Proceedings - NEWDIST Special Issue July 2016* (pp. pp.12, 339-350). Torino: DIST - Politecnico di Torino.
- Ugliotti, F. (2017). Utilizzi del modello BIM per il FM. In A. Osello, F. Ugliotti, A. Osello, & F. Ugliotti (A cura di), *BIM: verso Il catasto del futuro. Conoscere, digitalizzare, condividere. Il caso studio della Città di Torino* (p. 18, 56-73). Roma, Italy: Gangemi Editore spa.
- Ugliotti, F., De Luca, D., & Osello, A. (2017). Il disegno e le tecnologie nel processo di comunicazione delle informazioni. Napoli.
- Ugliotti, F., Dellosta, M., & Osello, A. (2016). BIM-based energy analysis using Edilclima EC770 plugin. Case study: Archimede Library, EEB Project. *Procedia Engineering, Elsevier*, 6.

- Ugliotti, F., Dellosta, M., & Osello, A. (2016). Exploitation of a BIM model for the built heritage digitalization. *3D MODELING & BIM. Applications and possible future developments*. (pp. 204-220). Roma: DEI.
- UNI. (1981). UNI 8290:1981-1. *Edilizia residenziale. Sistema tecnologico. Classificazione e terminologia*. Italy: UNI.
- UNI. (1983, 06 30). UNI 8290-2:1983. *Residential building. Building elements. Analysis of requirements*. Italy: UNI.
- UNI. (2017, 01 26). UNI 11337-4:2017. *Edilizia e opere di ingegneria civile - Gestione digitale dei processi informativi delle costruzioni - Parte 4: Evoluzione e sviluppo informativo di modelli, elaborati e oggetti*. Italia: UNI.
- UNI, & CEN. (2007). UNI EN 15221-1:2007. *Facility Management - Terms and definitions*. Italia.
- United Nations, D. (2014). *World Urbanization Prospects. The 2014 Revision, Highlights*. Tratto il giorno 02 02, 2016 da <https://esa.un.org/unpd/wup/publications/files/wup2014-highlights.Pdf>
- United States. (2007). *National Building Information Modeling Standard Version 1 - Part 1: Overview, Principles, and Methodologies*.
- Vetriani, G., & Marolda, M. (1983). *Piano di Classificazione PCSfB*. Milan: ITEC editrice.
- VINCI Energies. (2017). *Being innovative in using buildings with BIM FM*. Retrieved 08 11, 2017, from VINCI Energies: <http://www.vinci-energies.com/en/our-news/newscenter/being-innovative-in-using-buildings-with-bim-fm/>
- Volk, R., Stengel, J., & Schultmann, F. (2014). Building Information Models (BIM) for existing buildings – literature review and future needs. *Automation in Construction* 38, 109-127.
- Yalcinkaya, M., & Singh, V. (2014). Building Information Modeling (BIM) for Facilities Management - Literature Review and Future Needs. *IFIP Advances in Information and Communication Technology, AICT-442. 11th*

*IFIP International Conference on Product Lifecycle Management (PLM),
Yokohama, Japan, pp. 1-10. Springer.*

Zanotti, L. (2015, 07 08). *Realtà aumentata: una tecnologia, tantissime applicazioni.* Tratto il giorno 04 04, 2017 da INTERNET4THINGS: <http://www.internet4things.it/smart-building/realta-aumentata-una-tecnologia-tantissime-applicazioni/>

Appendix A: List of Publications

- Ugliotti, F., De Luca, D., & Osello, A. (2017). Il disegno e le tecnologie nel processo di comunicazione delle informazioni/Drawing and technologies in the information communication process., Conference: XXXIX International Meeting of Theachers of Representation Disciplines, Territories and frontiers of representation, September 14-16, 2017. Naples, Italy.
- Amaro, G., Raimondo, A., Erba, D., & Ugliotti, F. (2017). A BIM-based approach supporting Fire Engineering. In E. Nigro, & A. Bilotta (Ed.), IFireSS 2017, 2nd International Fire Safety Symposium. Conference: IFireSS - International Fire Safety Symposium, June 7-9, 2017, pp. 137-144. Naples, Italy: Doppiavoce.
- Bottaccioli, L., Aliberti, A., Ugliotti, F. M., Osello, A., Macii, E., Patti, E., et al. (2017). Building energy modelling and monitoring by integration of IoT devices and Building Information Models., Conference: Building Digital Autonomy for a Sustainable World (COMPSAC), July 4-8, 2017, p. 9. Turin, Italy.
- De Luca, D., Del Giudice, M., Dellosta, M., Fonsati, A., Osello, A., & Ugliotti, F. (2017). Augmented and virtual reality for smart cities users'awareness. In L. Gomez Chova, A. López Martínez, & I. Candel Torre (Ed.), INTED 2017, 11th International Technology, Education and Development Conference. Conference: INTED 2017, 11th International Technology, Education and Development, March 6-8, 2017, pp. 4333-4342. Valencia, Spain: IATED Academy.
- Osello, A., & Ugliotti, F. (2017). *BIM: verso Il catasto del futuro. Conoscere, digitalizzare, condividere. Il caso studio della Città di Torino.* (A. Osello, & F. Ugliotti, Eds.) Roma, Italy: Gangemi Editore spa.
- Ugliotti, F. (2017). Acquisizione dei dati e rilievo speditivo. In A. Osello, F. Ugliotti, A. Osello, & F. Ugliotti (Eds.), *BIM: verso Il catasto del futuro. Conoscere, digitalizzare, condividere. Il caso studio della Città di Torino* (pp. 5, 45-49). Roma, Italy: Gangemi Editore spa.

- Ugliotti, F. (2017). Utilizzi del modello BIM per il FM. In A. Osello, F. Ugliotti, A. Osello, & F. Ugliotti (A cura di), *BIM: verso Il catasto del futuro. Conoscere, digitalizzare, condividere. Il caso studio della Città di Torino* (p. 18, 56-73). Roma, Italy: Gangemi Editore spa.
- Ugliotti, F. (2017). Interoperabilità BIM per la gestione degli spazi. In A. Osello, F. Ugliotti, A. Osello, & F. Ugliotti (A cura di), *BIM: verso Il catasto del futuro. Conoscere, digitalizzare, condividere. Il caso studio della Città di Torino* (p. 4, 94-97). Roma, Italy: Gangemi Editore spa.
- Amaro, G., Raimondo, A., Anfosso, C., Erba, D., & Ugliotti, F. (2017). Tecnologie avanzate a supporto delle attività di Survey e Audit nell'ambito dei servizi di Maintenance e Safety Management. *INGEGNO*. IMREADY Srl.
- Amaro, G., Raimondo, A., Erba, D., & Ugliotti, F. (2017). Il BIM per il Fire Engineering e per il Safety Management. *INGEGNO, Gennaio 2017*, 5, 51.
- Moglia, G., Ugliotti, F., Dellosta, M., & Osello, A. (2016). Virtual and Augmented Reality for citizen involvement in the evaluation of the urban transformation. In S. Bertocci, & M. Bini (Ed.), *Le ragioni del disegno. The reasons of drawing. Pensiero, forma e modello nella gestione della complessità. Thought, shape and model in the complexity management. Conference: XXXVIII International Meeting of Teachers of Representation Disciplines, The Reasons of Drawing, September 14-16, 2016*, pp. 4, 1197-1200. Gangemi Editore spa.
- Ugliotti, F., Dellosta, M., & Osello, A. (2016). A BIM-based energy analysis using Edilclima EC770 plug-in. Case study: Archimede Library, EEB Project. *Procedia Engineering, WMCAUS 2016* (161 (2016)), 6, 3-8.
- Osello, A., Barone, L., Davardoust, S., De Luca, D., Del Giudice, M., Dellosta, M., et al. (2016). The Centrality of Representation with BIM/La Centralità della Rappresentazione con il BIM. *DISEGNARECON, Vol 9, No 16 (2016)*, 12.
- Semeraro, F., Ugliotti, F., Osello, A., Del Giudice, M., & Rapetti, N. (2016). The DIMMER project user awareness: Innovative Gamification approach through Augmented Reality. In L. Gomez Chova, A. López Martínez, & I.

-
- Candel Torre (Ed.), *EDULEARN16 Proceedings. Conference: 8th International Conference on Education and New Learning Technologies, July 4-6, 2016*, pp. 9, 5104-5112. Barcelona, Spain: IATED Academy.
- Osello, A., Ugliotti, F., Semeraro, F., & SYSTEMA. (2016, 05 18). *Il BIM orientato al Facility Management. Nuove opportunità di gestione del patrimonio edilizio nell'era della transizione digitale*. Retrieved from INFOBUILT: <http://www.infobuild.it/approfondimenti/bim-orientato-facility-management/>
- Ugliotti, F., Dellosta, M., & Osello, A. (2016). Possibili utilizzi di un modello BIM per la digitalizzazione degli edifici esistenti/Exploitation of a BIM model for the built heritage digitization. In T. Empler (Ed.), *3DModeling&BIM. Applicazioni e possibili futuri sviluppi/3DModeling&BIM. Applications and possible future developments. Conference: Workshop 3DModeling&BIM. Applicazioni e possibili futuri sviluppi, April 20-21, 2016*, pp. 17, 204-220. Roma, Italy: DEI s.r.l.
- Torabi Moghdam, S., Lombardi, P., Ugliotti, F., Osello, A., & Mutani, G. (2016). BIM-GIS Modelling for Sustainable Urban Development. *NEWDIST SPECIAL ISSUE (July 2016), Conference: Sustainable Built Environment towards port-carbon Cities SBE16, 2016, Turin*, pp. 12,339-350. Turin, Italy.
- Ugliotti, F., Marcos Guinea, A., Osello, A., D'Arpa, A., Bellia, A., & Portolese, G. (2015). Turin Smart City: BIM and interoperability for data management. In G. Novello, & A. Marotta (Ed.), *Disegno & Città/Drawing & City. Conference: XXXVII International Meeting of Theachers of Representation Disciplines, Drawing & City, September 17-19, 2015. Turin, Italy.*, pp. 5, 1191-1195. Gangemi Editore spa.
- Ugliotti, F., & Osello, A. (2015). From Polito to Smart Polito: data collection and visualization for energy saving and building management. *Conference: International Summer School on Sustainable University Campuses, September 14-18, 2015, Turin, Italy.*
- Ugliotti, F. (2015). La raccolta dei dati ed il rilievo speditivo degli edifici esistenti per la gestione dei grandi patrimoni immobiliari. In A. Osello, & A. Osello (A cura di), *Building Information Modelling, Geographic Information*

System, Augmented Reality per il Facility Management (p. 14, 50-63).
Palermo, Italy: Dario Flaccovio Editore.

Ugliotti, F. (2015). La gestione dei dati per il FM. In A. Osello, & A. Osello (Ed.), *Building Information Modelling, Geographic Information System, Augmented Reality per il Facility Management* (pp. 14, 170-183).
Palermo, Italy: Dario Flaccovio Editore.

Ugliotti, F. (2015). L'utilizzo della Realtà Aumentata per il Facility Management.
In A. Osello, & A. Osello (Ed.), *Building Information Modelling, Geographic Information System, Augmented Reality per il Facility Management* (pp. 8, 278-285).
Palermo, Italy: Dario Flaccovio Editore.

Osello, A., Del Giudice, M., Marcos Guinea, A., Rapetti, N., Ronzino, A., Ugliotti, F., et al. (2015). Augmented Reality and gamification approach within the DIMMER Project. In L. Gomez Chova, A. López Martínez, & I. Candel Torre (Ed.), *INTED2015 Proceedings. Conference: 9th International Technology, Education and Development Conference, March 2-3, 2015*, pp. 8, 2707-2714. Madrid, Spain: IATED Academy.

Erba, D., Osello, A., Semeraro, F., & Ugliotti, F. (2015). Perchè Quando e Come usare il BIM per il Facility Management in Italia. *Report developed as part of a research promoted by Systema S.r.l. and Autodesk Inc.*

A.1. International Journals

Amaro, G., Raimondo, A., Erba, D., & Ugliotti, F. (2017). Il BIM per il Fire Engineering e per il Safety Management. *INGEGNO*, *Gennaio 2017*, 5, 51.

Ugliotti, F., Dellosta, M., & Osello, A. (2016). A BIM-based energy analysis using Edilclima EC770 plug-in. Case study: Archimede Library, EEB Project. *Procedia Engineering, WMCAUS 2016* (161 (2016)), 6, 3-8.

Osello, A., Barone, L., Davardoust, S., De Luca, D., Del Giudice, M., Dellosta, M., et al. (2016). The Centrality of Representation with BIM/La Centralità della Rappresentazione con il BIM. *DISEGNARECON*, *Vol 9, No 16* (2016), 12.

A.2. Book

Osello, A., & Ugliotti, F. (2017). *BIM: verso Il catasto del futuro. Conoscere, digitalizzare, condividere. Il caso studio della Città di Torino*. (A. Osello, & F. Ugliotti, Eds.) Roma, Italy: Gangemi Editore spa.

A.3. Book Chapters

- Ugliotti, F. (2017). Acquisizione dei dati e rilievo speditivo. In A. Osello, F. Ugliotti, A. Osello, & F. Ugliotti (Eds.), *BIM: verso Il catasto del futuro. Conoscere, digitalizzare, condividere. Il caso studio della Città di Torino* (pp. 5, 45-49). Roma, Italy: Gangemi Editore spa.
- Ugliotti, F. (2017). Utilizzi del modello BIM per il FM. In A. Osello, F. Ugliotti, A. Osello, & F. Ugliotti (A cura di), *BIM: verso Il catasto del futuro. Conoscere, digitalizzare, condividere. Il caso studio della Città di Torino* (p. 18, 56-73). Roma, Italy: Gangemi Editore spa.
- Ugliotti, F. (2017). Interoperabilità BIM per la gestione degli spazi. In A. Osello, F. Ugliotti, A. Osello, & F. Ugliotti (A cura di), *BIM: verso Il catasto del futuro. Conoscere, digitalizzare, condividere. Il caso studio della Città di Torino* (p. 4, 94-97). Roma, Italy: Gangemi Editore spa.
- Ugliotti, F. (2015). La raccolta dei dati ed il rilievo speditivo degli edifici esistenti per la gestione dei grandi patrimoni immobiliari. In A. Osello, & A. Osello (A cura di), *Building Information Modelling, Geographic Information System, Augmented Reality per il Facility Management* (p. 14, 50-63). Palermo, Italy: Dario Flaccovio Editore.
- Ugliotti, F. (2015). La gestione dei dati per il FM. In A. Osello, & A. Osello (Ed.), *Building Information Modelling, Geographic Information System, Augmented Reality per il Facility Management* (pp. 14, 170-183). Palermo, Italy: Dario Flaccovio Editore.
- Ugliotti, F. (2015). L'utilizzo della Realtà Aumentata per il Facility Management. In A. Osello, & A. Osello (Ed.), *Building Information Modelling, Geographic Information System, Augmented Reality per il Facility Management* (pp. 8, 278-285). Palermo, Italy: Dario Flaccovio Editore.

A.4. Proceedings of International Conferences

- Ugliotti, F., De Luca, D., & Osello, A. (2017). Il disegno e le tecnologie nel processo di comunicazione delle informazioni/Drawing and technologies in the information communication process., Conference: XXXIX International Meeting of Theachers of Representation Disciplines, Territories and frontiers of representation, September 14-16, 2017. Naples, Italy.
- Amaro, G., Raimondo, A., Erba, D., & Ugliotti, F. (2017). A BIM-based approach supporting Fire Engineering. In E. Nigro, & A. Bilotta (Ed.), IFireSS 2017, 2nd International Fire Safety Symposium. Conference: IFireSS - International Fire Safety Symposium, June 7-9, 2017, pp. 137-144. Naples, Italy: Doppiavoce.
- Bottaccioli, L., Aliberti, A., Ugliotti, F. M., Osello, A., Macii, E., Patti, E., et al. (2017). Building energy modelling and monitoring by integration of IoT devices and Building Information Models., Conference: Building Digital Autonomy for a Sustainable World (COMPSAC), July 4-8, 2017, p. 9. Turin, Italy.
- De Luca, D., Del Giudice, M., Dellosta, M., Fonsati, A., Osello, A., & Ugliotti, F. (2017). Augmented and virtual reality for smart cities users'awareness. In L. Gomez Chova, A. López Martínez, & I. Candel Torre (Ed.), INTED 2017, 11th International Technology, Education and Development Conference. Conference: INTED 2017, 11th International Technology, Education and Development, March 6-8, 2017, pp. 4333-4342. Valencia, Spain: IATED Academy.
- Moglia, G., Ugliotti, F., Dellosta, M., & Osello, A. (2016). Virtual and Augmented Reality for citizen involvement in the evaluation of the urban transformation. In S. Bertocci, & M. Bini (Ed.), *Le ragioni del disegno. The reasons of drawing. Pensiero, forma e modello nella gestione della complessità. Thought, shape and model in the complexity management.* Conference: XXXVIII International Meeting of Theachers of Representation Disciplines, *The Reasons of Drawing*, September 14-16, 2016, pp. 4, 1197-1200. Gangemi Editore spa.

- Ugliotti, F., Dellosta, M., & Osello, A. (2016). A BIM-based energy analysis using Edilclima EC770 plug-in. Case study: Archimede Library, EEB Project. *Procedia Engineering, WMCAUS 2016* (161 (2016)), 6, 3-8.
- Semeraro, F., Ugliotti, F., Osello, A., Del Giudice, M., & Rapetti, N. (2016). The DIMMER project user awareness: Innovative Gamification approach through Augmented Reality. In L. Gomez Chova, A. López Martínez, & I. Candel Torre (Ed.), *EDULEARN16 Proceedings. Conference: 8th International Conference on Education and New Learning Technologies, July 4-6, 2016*, pp. 9, 5104-5112. Barcelona, Spain: IATED Academy.
- Ugliotti, F., Dellosta, M., & Osello, A. (2016). Possibili utilizzi di un modello BIM per la digitalizzazione degli edifici esistenti/Exploitation of a BIM model for the built heritage digitization. In T. Empler (Ed.), *3DModeling&BIM. Applicazioni e possibili futuri sviluppi/3DModeling&BIM. Applications and possible future developments. Conference: Workshop 3DModeling&BIM. Applicazioni e possibili futuri sviluppi, April 20-21, 2016*, pp. 17, 204-220. Roma, Italy: DEI s.r.l.
- Torabi Moghdam, S., Lombardi, P., Ugliotti, F., Osello, A., & Mutani, G. (2016). BIM-GIS Modelling for Sustainable Urban Development. *NEWDIST SPECIAL ISSUE (July 2016), Conference: Sustainable Built Environment towards port-carbon Cities SBE16, 2016, Turin*, pp. 12,339-350. Turin, Italy.
- Ugliotti, F., Marcos Guinea, A., Osello, A., D'Arpa, A., Bellia, A., & Portolese, G. (2015). Turin Smart City: BIM and interoperability for data management. In G. Novello, & A. Marotta (Ed.), *Disegno & Città/Drawing & City. Conference: XXXVII International Meeting of Teachers of Representation Disciplines, Drawing & City, September 17-19, 2015. Turin, Italy.*, pp. 5, 1191-1195. Gangemi Editore spa.
- Ugliotti, F., & Osello, A. (2015). From Polito to Smart Polito: data collection and visualization for energy saving and building management. *Conference: International Summer School on Sustainable University Campuses, September 14-18, 2015, Turin, Italy.*
- Osello, A., Del Giudice, M., Marcos Guinea, A., Rapetti, N., Ronzino, A., Ugliotti, F., et al. (2015). Augmented Reality and gamification approach

within the DIMMER Project. In L. Gomez Chova, A. López Martínez, & I. Candel Torre (Ed.), *INTED2015 Proceedings. Conference: 9th International Technology, Education and Development Conference, March 2-3, 2015*, pp. 8, 2707-2714. Madrid, Spain: IATED Academy.

A.5. Other

Amaro, G., Raimondo, A., Anfosso, C., Erba, D., & Ugliotti, F. (2017). *Tecnologie avanzate a supporto delle attività di Survey e Audit nell'ambito dei servizi di Maintenance e Safety Management*. INGEGNO. IMREADY Srl.

Osello, A., Ugliotti, F., Semeraro, F., & SYSTEMA. (2016, 05 18). *Il BIM orientato al Facility Management. Nuove opportunità di gestione del patrimonio edilizio nell'era della transizione digitale*. Retrieved from INFOBUILT: <http://www.infobuild.it/approfondimenti/bim-orientato-facility-management/>

Erba, D., Osello, A., Semeraro, F., & Ugliotti, F. (2015). *Perchè Quando e Come usare il BIM per il Facility Management in Italia. Report developed as part of a research promoted by Systema S.r.l. and Autodesk Inc.*