



POLITECNICO DI TORINO
Repository ISTITUZIONALE

Powertrain Assembly Lines Automatic Configuration Using a Knowledge Based Engineering Approach

Original

Powertrain Assembly Lines Automatic Configuration Using a Knowledge Based Engineering Approach / Ascheri, ANDREA EGIDIO. - (2016).

Availability:

This version is available at: 11583/2644260 since: 2016-06-22T11:29:54Z

Publisher:

Politecnico di Torino

Published

DOI:10.6092/polito/porto/2644260

Terms of use:

Altro tipo di accesso

This article is made available under terms and conditions as specified in the corresponding bibliographic description in the repository

Publisher copyright

(Article begins on next page)

POLITECNICO DI TORINO

DOCTORAL SCHOOL

PhD in Production and Industrial Systems Engineering – XVIII Cycle

PhD Thesis

**Powertrain Assembly Lines Automatic Configuration
Using a Knowledge Based Engineering Approach**



Andrea Egidio Ascheri

Tutor

Ing. Eleonora Atzeni

Ing. Massimo Ippolito (Comau S.p.A)

March 2016

Dicebat Bernardus Carnotensis nos esse quasi nanos, gigantium humeris insidentes, ut possimus plura eis et remotiora videre, non utique proprii visus acumine, aut eminentia corporis, sed quia in altum subvenimur et extollimur magnitudine gigantea.

Abstract

Technical knowledge and experience are intangible assets crucial for competitiveness. Knowledge is particularly important when it comes to complex design activities such as the configuration of manufacturing systems. The preliminary design of manufacturing systems relies significantly on experience of designers and engineers, lessons learned and complex sets of rules and is subject to a huge variability of inputs and outputs and involves decisions which must satisfy many competing requirements. This complicated design process is associated with high costs, long lead times and high probability of risks and reworks. It is estimated that around 20% of the designer's time is dedicated to searching and analyzing past available knowledge, while 40% of the information required for design is identified through personally stored information. At a company level, the design of a new production line does not start from scratch. Based on the basic requirements of the customers, engineers use their own knowledge and try to recall past layout ideas searching for production line designs stored locally in their CAD systems [1]. A lot of knowledge is already stored, and has been used for a long time and evolved over time. There is a need to retrieve this knowledge and integrate it into a common and reachable framework. Knowledge Based Engineering (KBE) and knowledge representation techniques are considered to be a successful way to tackle this design problem at an industrial level. KBE is, in fact, a research field that studies methodologies and technologies for capturing and re-using product and process engineering knowledge to achieve automation of repetitive design tasks [2]. This study presents a methodology to support the configuration of powertrain assembly lines, reducing design times by introducing a best practice for production systems provider companies. The methodology is developed in a real industrial environment, within Comau S.p.A., introducing the role of a knowledge engineer. The approach includes extraction of existing technical knowledge and implementation in a knowledge-based software framework. The macro system design requirements (e.g. cycle time, production mix, etc.) are taken as input. A user driven procedure guides the designer in the definition of the macro layout-related decisions and in the selection of the equipment to be allocated within the project. The framework is then integrated with other software tools allowing the first phase design of the line including a technical description and a 2D and 3D CAD line layout. The KBE application is developed and tested on a specific powertrain assembly case study. Finally, a first validation among design engineers is presented, comparing traditional and new approach and estimating a cost-benefit analysis useful for future possible KBE implementations.

Estratto

Oggi giorno, competenze ed esperienza sono asset intangibili di estremo valore per le aziende. L'esperienza è una variabile fondamentale soprattutto in attività ad alto valore aggiunto come la progettazione di sistemi complessi. In particolare, la progettazione preliminare di linee di montaggio è un'attività che si basa fortemente su esperienze passate e soluzioni tecniche già esistenti. Ingegneri e progettisti, basandosi sulle richieste del cliente, cercano di conciliare i diversi requisiti in una soluzione ottimizzata di linea. Si stima che ingegneri e progettisti in questa fase occupino circa il 20% del tempo alla ricerca di soluzioni passate. Gran parte della conoscenza che è utilizzata durante la progettazione è implicita perché risiede nelle menti e nell'esperienza delle persone e spesso semplicemente rinchiusa in archivi personali e non a disposizione dell'azienda. Per questi motivi, vi è un impellente bisogno di trovare questa conoscenza passata, formalizzarla e metterla a disposizione di tutta l'azienda al fine di migliorare le performance della progettazione. A livello scientifico esistono diversi approcci che cercano di risolvere la mancanza di competenze ed esperienza a livello aziendale. Uno di tali approcci è il *Knowledge Based Engineering* (KBE) ovvero progettazione basata sulla conoscenza. Il KBE è infatti una disciplina che studia metodologie e tecniche per l'automazione della progettazione. Le tecniche di KBE sono quindi un misto tra tecniche di OOP (*object-oriented programming*) e sistemi CAD utilizzate per l'automazione di azioni ripetitive che in fase di progettazione portano via tempo e risorse. Il presente studio tratta lo sviluppo e la applicazione di una metodologia KBE in ambito strettamente industriale. Partendo dalle specifiche dei progettisti e dalle informazioni raccolte si sviluppa un prototipo di software in grado di automatizzare diverse fasi della progettazione preliminare di linee di montaggio. Il software a fronte di un inserimento di alcuni requisiti di alto livello della linea (ad es: tempo ciclo, forma del layout ecc.) genera in output secondo le regole impostate una descrizione tecnica della linea e un layout preliminare collegandosi a un CAD 2D e 3D. Il presente studio è interamente sviluppato in Comau S.p.A. a partire dall'acquisizione della conoscenza fino allo sviluppo dell'applicazione per un caso studio su una linea di montaggio testa cilindri. In aggiunta alla letteratura esistente sul KBE si propone uno schema di valutazione dell'applicazione e del possibile inserimento in un contesto aziendale.

Acknowledgments

This thesis would not have been possible without the support of many people. This paragraph is not enough for thanking everybody.

A special acknowledgment goes to Regione Piemonte and the European Commission for funding and promoting high apprenticeship education.

I would like to express my sincere gratitude to my supervisors Professor Eleonora Atzeni at Politecnico di Torino for her encouragement and guidance and Ing. Massimo Ippolito at Comau for the invaluable advice.

An important acknowledgment goes to the colleagues of Politecnico di Milano, department of Mechanical Engineering – Methods and Tools for Product Design. In particular prof. Giorgio Colombo and his collaborators, Ing. Francesco Furini and Ing. Marco Rossoni who provided expertise and passion that made this research possible.

I would like to thank all the colleagues from Comau that helped me during this research.

The Standard and R&D grouped welcomed me and always helped the research with great commitment. I would like to give special thanks to Matteo and Raffaele who have been since the beginning of this path helpful colleagues and good friends.

The Proposal and Estimating team of Comau Powertrain has been always very willing to share knowledge and experiences to guide me through this long journey. A special thanks goes to Maurizio, Simone and Alessandro who shared with me the path towards the application of a new software with enthusiasm and passion.

The System engineering team taught me the basics of simulations and showed me the importance of the real world manufacturing sites. I am particularly grateful to Stefano and Elena for their guidance and appreciation.

I am grateful to my academic colleague from Politecnico di Torino, Gianluca who in several occasions provided me with support and insightful advice for the research.

Finally and most importantly I could not have undertaken my journey without the strong encouragement and practical help from all my loved ones. This work is dedicated to them.

Table of Contents

Abstract.....	5
Estratto	7
Acknowledgments	9
Table of Contents	11
Nomenclature	15
1. Framework and Objective for the research	17
Abstract.....	17
1.1. Introduction	18
1.2. Framework.....	18
1.3. Problem	19
1.4. Research Questions.....	20
1.5. Approach	21
1.6. Structure of the Thesis	21
2. Powertrain Assembly Systems in Comau	23
Abstract.....	23
2.1. Introduction	24
2.1.1. Comau’s Framework and Project Life Cycle.....	24
2.2. Powertrain Assembly Systems	26
2.2.1. Powertrain Assembly Lines.....	27
2.3. PA R&D and Standard Department	28
2.3.1. Process Modularity.....	29
2.3.2. Equipment Modularity	30
2.4. Proposal Tool and Flow	34
2.4.1. Proposal Engineering As-is situation	35
3. State of the Art – Knowledge Based Engineering.....	37
Abstract.....	37
3.1. Engineering Design.....	38
3.1.1. Assembly Line Design	38
3.2. Knowledge Technologies and KBE systems	41
3.2.1. KBE definition	41
3.2.2. KBE History.....	41
3.2.3. KBE literature and related fields	42

Table of Contents

4. Research Methodology	45
Abstract.....	45
4.1. High-Level Architecture of the Study	46
4.2. Methodology	47
4.2.1. Existing Methodologies.....	48
4.2.2. Proposed Methodology	48
4.2.3. Proposal Engineering – To Be situation after KBE implementation	51
5. Application	53
Abstract.....	53
5.1. Specification Definition	54
5.1.1. Resources – Knowledge Engineer	55
5.1.2. Case Study – Cylinder Head Assembly.....	56
5.2. Knowledge Acquisition	59
5.3. Knowledge Formalization	64
5.3.1. Powertrain Assembly Line.....	64
5.3.2. Design Process.....	65
5.3.3. Rules	70
5.3.4. Assembly Line Balancing Problem (ALBP)	72
5.4. Knowledge Integration	78
5.4.1. KBE Modularity.....	79
5.4.2. Databases.....	82
5.4.3. Interface with other tools	84
5.5. Knowledge Implementation	88
5.6. Evaluation	95
5.6.1. α Test Case – Pilot	96
5.6.2. β Test Case – Design Alternatives.....	101
5.7. Business and Organizational Case.....	104
5.7.1. Cost-Benefit Analysis	105
5.7.2. SWOT Analysis.....	108
5.7.3. Market Outlook	109
5.7.4. Patent Landscaping.....	111
5.7.5. Conclusions	114
6. Related work and Challenges	117

Table of Contents

Abstract.....	117
6.1. Integrated Proposal Tool	118
6.1.1. Methodology.....	118
6.1.2. Integration with KBE Approach	121
6.1.3. Conclusions and Next Steps	122
6.2. Discrete Event Simulation (DES)	123
6.2.1. Methodology.....	124
6.2.2. DES in the KBE Application.....	124
6.2.3. Conclusions and Next Steps	125
6.3. ProRegio	126
6.3.1. Methodology.....	126
6.3.2. ProRegio and the KBE application	128
6.3.3. Preliminary Scientific Results	128
6.3.4. Conclusions and Next Steps	130
6.4. Automate Guided Vehicles Conveyor System	131
6.4.1. Methodology.....	132
6.4.2. Alternative Layout	133
6.4.3. Discrete Event Simulation.....	137
6.4.4. AGVs and KBE application.....	140
6.4.5. Conclusions and Next Steps	140
6.5. Engineering KPIs.....	142
6.5.1. Methodology.....	142
6.5.2. Design Performance with Frontier Analysis.....	143
6.5.3. Engineering KPIs and the KBE application	146
6.5.4. Conclusions and Next Steps	147
7. Conclusions.....	149
Abstract.....	149
7.1. Introduction	150
7.2. Empirical Findings	150
7.3. Discussions and Implications	152
7.4. Limitations	152
7.5. Dissemination	153
7.6. Next Steps and Future Work.....	154

Table of Contents

Bibliography	157
List of Figures	163
List of Tables	165

Nomenclature

BiW	Body-in-White
PA	Powertrain Assembly and Test
BRIC	Brazil, Russia, India and China
DA	Design Automation
DES	Discrete Event Simulation
KA	Knowledge Acquisition
KBE	Knowledge Based Engineering
KM	Knowledge Management
ROI	Return on Investment
RFQ	Request for Quotation
PA	Powertrain Assembly & Test
OEM	Overall Equipment Manufacturer
AGV	Automated Guided Vehicle
API	Application Programming Interface
TCO	Total Cost of Ownership
DEA	Data Envelopment Analysis
KPI	Key Performance Indicator
BOM	Bill of Materials
BOP	Bill of Process

1. Framework and Objective for the research

Abstract

This first introductory chapter highlights the rationale behind this research work. Here the company that conducted the research work (i.e. Comau) and the framework in which it operates is presented. At a company level there is a need to adapt to changing market conditions by improving design engineering processes by leveraging existing technical knowledge and experience. Knowledge Based Engineering (KBE) techniques are considered to be an effective way to capture existing technical knowledge and to automate repetitive design tasks reducing design times and errors. The approach will be applied to the configuration of a high level manufacturing system during the proposal engineering phase. Finally, the overall structure of the thesis is expressed in detail.

1.1. Introduction

The present work is the result of a three-year apprenticeship PhD programme jointly run by Politecnico di Torino and Comau S.p.A. The title of the programme funded by the European Social Funds and promoted by Regione Piemonte is “Management and Improvement of Engineering Processes Worldwide”. The start of the programme followed a specific Comau request for a need to 1) improve efficiency in the current engineering processes, 2) collect and store existing technical knowledge available in the company and 3) make it available to all Comau facilities worldwide.

The present work is a report of the implemented solution to this problem and all the related activities that have been going on within Comau during the past three years. In particular, the following chapters describe the implementation of a Knowledge Based Engineering (KBE) approach to tackle the aforementioned issues. The implementation of this approach took place in the Comau Powertrain Assembly & Test business unit, namely in the proposal and estimating department. The development of this research work is strongly related with other activities in progress in the same department: the effort to standardize equipment and processes of the Powertrain Assembly (PA) and the adoption of a new software tool to improve the proposal engineering.

This research work has been partly conducted through a collaboration with the department of Mechanical Engineering of the Politecnico di Milano, namely the group researching the themes of methods and tools for product design. Some of the research ideas present in this work have been formalized and proposed in a European funded research project called ProRegio which is currently running and will continue for the next two years.

1.2. Framework

One of the driving pressures on businesses today is the need to adapt to the fast market expansion in the growing countries, such as Brazil, Russia, India, and China (BRIC). This trend is particularly confirmed in the automotive industry that is a crucial sector for all major economies [3]. For instance, in the global market of new powertrain assembly lines, China and Brazil together now represent from 60 to 70 percent of the total share [4]. It is expected that the BRICs’ share of global vehicle sales will edge towards the 50% mark by 2018. Established and BRIC markets are expected to converge in terms of customer demands and behaviour within the next 5–6 years. As a matter of fact, China has been the world’s largest automobile producer and market since 2009 [5]. Furthermore, customer are increasing their demands in terms of design customization, complexity and lead times [6].

This tendency pushes manufacturing equipment companies to lead the globalization process and effectively respond to customer requests both by improving engineering design processes and by managing existing technical knowledge as this fast grow may result in a shortage of resources and trained workforce that could negatively affect the business. Complex design activities rely mostly on knowledge and experience of designers. Thus, it is crucial to extract, transfer and make globally available existing knowledge to improve effectiveness in engineering activities. The technical knowledge shared globally at a company level, together with an integrated design approach could lead to more robust design outputs. Therefore, given the condition of a growing automation market there is a crucial need for engineering companies to operate on two directions: on one hand increase the automation of design tasks reducing development times and improve the evaluation of

design variants to satisfy the demand (i.e. Design Automation) and on the other hand manage existing technical knowledge to compete in the global marketplace overcoming scarcity of experienced resources.

The problem of Design Automation (DA) has great relevance both at scientific and industrial level. The automation of the design process can shorten lead-time and make the adaptation of products to different specifications easier. It can also help improving design performances since it reduces errors and increases repeatability of outputs [7, 8].

In research and industry a number of knowledge based approaches have been introduced aiming to capture, store and reuse existing design knowledge [1]. In particular, the so-called Knowledge Based Engineering (KBE) approach is a more automated way of designing products and processes. KBE is, in fact, a research field that studies methodologies and technologies for capturing and re-using product and process engineering knowledge to achieve automation of repetitive design tasks. CAx software tools combined together with knowledge systems are expected to lead to a breakthrough in design engineering that is undergoing a transformation from an informal and largely experience-based discipline to a science-based domain [2].

This work describes the ongoing research efforts for the development of a new approach to manufacturing system design automation within Comau S.p.A. (Comau), a leading provider of automation solutions for the automotive industry.

The aim of this study is to implement and verify the feasibility of a knowledge based framework for the early stage design of powertrain assembly lines (i.e. engines, cylinder heads, transmissions and suspensions assembly lines). This work focuses on the preliminary design, or embodiment design according to the classification by Pahl [9]. During the preliminary design phase, customer requirements are transformed into an initial physical design solution, represented by a graphical arrangement [10], analysis and cost estimation. The novelty is that the development of the KBE approach takes place in a real industrial environment with all its complexity and specific requirements. Moreover, this study adds to the research knowledge a quantitative validation of the implemented KBE application which is often one of the missing aspects in KBE-related research as pointed out by Verhagen [2].

For the purpose of this study, we acquire internal knowledge of the company about system architecture and design process and implement it in a knowledge based application built on an object-oriented approach. The KBE application uses different software tools to provide a series of functionalities currently used in the preliminary design phase such as 2D and 3D CAD layout and a technical description of the assembly line . The obtained result is the formalization of existing technical knowledge in the company related to powertrain assembly lines and a consequent reduction in design times.

1.3.Problem

At a company level, there is a pressing need to adapt to current market conditions by increasing efficiency in engineering processes in terms of design quality, design times and costs.

This thesis thus focuses on the proposal engineering phase, that if we take as an example Pahl [9] definition can be considered as the preliminary or embodiment design.

Production line design is not a highly creative task. It does follow a different approach from a new product design from scratch. It is mostly about using existing solutions and putting them together while respecting a series of design constraint such as in a multidisciplinary design problem. If we consider the traditional design stages, the layout design is the first step of the engineering design of a production system. However, we cannot speak of a 'conceptual design' as the main effort involved in this phase is not creativity. The work performed by the designers instead is highly based on experience and on integrating different elements to perform a process. The proposal engineer uses existing solutions (i.e. workstations, machines, conveyors...) yet he explores new alternatives. At the same time, the designer has to integrate all the elements in a system considering all the relationships between the various variables. For these reasons the engineering proposal combines both elements of a detailed design and typical situation of a conceptual design phase. Complexity of the designed system may vary a lot and thus the design activity can range from a well-defined problem to a completely unstructured and ill-defined design.

The main problems currently encountered during the proposal design phase are:

- Lack of explicit design knowledge. Company knowledge currently resides in the minds of the designers. This knowledge is not explicitly formalized and cannot be made available to new company hires with little or no design experiences. While the company is growing, many of its skilled people get close to retirement age. At present, there is not a consolidated way of transferring their knowledge to new hires joining the company a part from direct knowledge exchange which is not always a viable solutions due to several barriers (including geographical locations). There is a need to make this knowledge available in a sharable format and easy to transfer.
- Lack of a common design framework. Comau is a global company with operations in different regions of the world. Being a global company poses some serious issues in managing different design approaches. Currently, there is not a consolidated design framework and this results often in different technical solutions provided by the same company in different regions of the world. There is a need to standardize and make globally available a design framework to reduce errors and increase knowledge sharing at a global level.

1.4. Research Questions

Based on the identified problem, three main research questions were identified. These questions can be summarized by the followings:

- *How can a knowledge based approach improve design performances in an engineering company?*
- *How can a knowledge based approach help retaining existing technical knowledge in an engineering company?*
- *How can design automation and knowledge based approach be applied to the preliminary design of manufacturing systems in an industrial environment?*

1.5.Approach

Retaining expertise, wisdom and knowledge is a competitive advantage in the current marketplace with short lead times and variable requests.

The application of Knowledge Based Engineering can be a solution for the above stated design problems. The definition of Knowledge Based Engineering is manifold and is not unique. Indeed, one of the characterizing elements of a KBE system is to be software tool or technique able to collect, store and reuse product and process knowledge in an integrated way. At the same time, KBE is a software tool that complements a CAD system and is able to quickly visualize and update a generative virtual prototype of a product. By many authors, KBE is considered to be at the same time a methodology and a computer application.

Among many, the main advantages of a KBE systems can be:

- More design output given the same effort input;
- More accurate (coherent with rules) design output;
- More free time for designers and engineer for creative and added-value thinking;
- Store and reuse of knowledge;
- Accessibility to a non-expert designer/engineer;
- Integrated output;

The objective of this research activity is to capture, formalize and implement in a KBE application the existing company knowledge. The acquired knowledge will be in the domain of the preliminary design of PA lines. Once this knowledge will be implemented in a KBE application it should be available to all design engineers and facilitate their design tasks in terms of times and evaluation of solutions. The KBE application can be shared among design engineers in different regions of the world and increase the coherency of company designs by standardizing proposed technical solutions.

1.6.Structure of the Thesis

As anticipated, the present document is the result of a three-year period of work and research carried out between Comau and Politecnico di Torino. In this chapter we introduced the overall context of this thesis and stated the identified problem and the proposed solutions that we investigated. Chapter 2 deals specifically with Powertrain Assembly Systems and the modularity concepts of the line architecture. Chapter 3 tackles the state of the art of Knowledge Based Engineering and production lines design. The existing literature is analysed in detail and taken as a reference for the development of the work. Chapter 4 describes more in detail the research problem and the proposed approach while Chapter 5 goes through the application and results of the applied methodology. A specific insight on the organizational and business benefits of the introduction of this new approach represents the core of section 5.7. Chapter 6 deals with all the work carried out during this three-year period and strictly related to the research. Finally, chapter 7 draws some conclusions about the current study and sets directions for further research and future work. The structure of this document is visualized in Figure 1.

The present work reports in detail the research activities performed during the three-year PhD programme. Nevertheless some data and specific knowledge about the company assets is not disclosed due to confidentiality reasons.

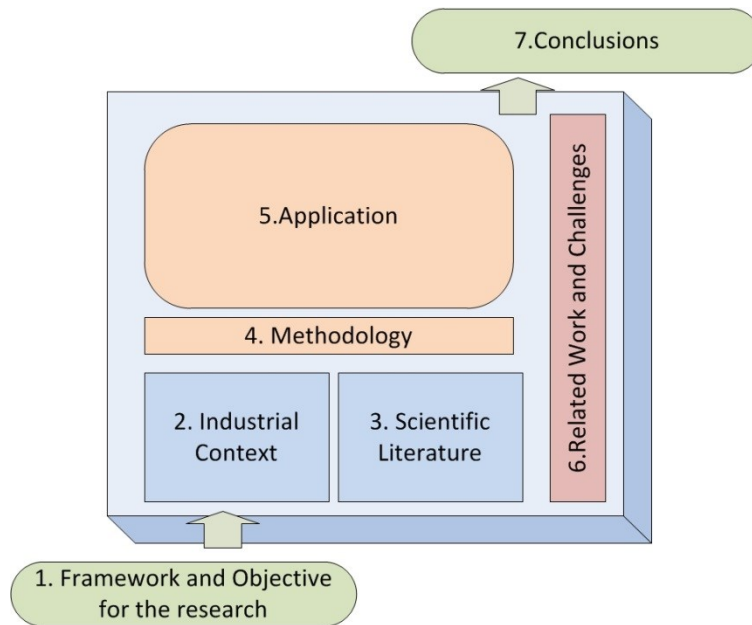

Figure 1: Structure of the thesis

2. Powertrain Assembly Systems in Comau

Abstract

This chapter deals more in detail with the scope of this research presenting assembly systems for powertrain components within Comau. Powertrain Assembly lines are made up of workstations that serially execute a series of operations to add components to the product being assembled. The concept of Comau assembly lines is based on a modular approach that is applied both to processes and equipment. This modular approach allows flexibility, scalability and reconfigurability of assembly systems increasing the use of built-to-order standard components providing tested technical solutions. These standard components are used by the proposal engineering department which is in charge of understanding customer requirements and providing a complete technical solution in the form of a system layout and description.

2.1.Introduction

As anticipated, automotive companies are tackling increasing global competition not only from traditional mature markets players but also from emerging countries. Automakers are aware of growing costs triggered by evolution in customer requirements, and so are shifting them on the suppliers side. Since Tier1 contractors are responsible for 69% of total automotive R&D, their products are going to considerably influence OEMs' outcomes, so that suppliers' share of value creation for vehicles is estimated to shift from 77% in 2012 to 81% by 2025. These numbers express the higher risks and responsibilities charged to automotive suppliers and explain the constant pressure they are receiving from car manufacturers [11].

In order to face these trends, suppliers in the last decades undertook a manufacturing globalization aiming at improving their presence in emerging markets. Today, suppliers are globalizing also their engineering capabilities with the purpose of cutting their product development costs. As consequence suppliers need a lean and flexible organizational structure to better react to market changes [12].

2.1.1. Comau's Framework and Project Life Cycle

Comau is a global supplier of industrial automation systems and services mainly for the automotive manufacturing sector. Over the years, by acquiring and integrating other companies, Comau broadened its presence all over the world, becoming a leading partner for the automotive industry in developing solutions for all industrial production programs. Comau is organized into 4 main Business Units: Body Assembly (dealing with welding of automotive body parts), Powertrain Machining & Assembly (assembly and metal cutting solutions for engines and transmissions), Robotics and Adaptive solutions (general purpose automation solutions).

Comau as a Tier 1 supplier has an active role in the automaker's supply chain. The value chain for Comau business corresponds to its Project Life Cycle, which can be described by Figure 2. Following the actions of *Market and Business Development* (P1) to explore the potential opportunities, the customer's Request for Quotation (RFQ) is the input for the *Proposal & Order Acquisition* (P2) process. A technical and commercial proposal is made and negotiated with the customer during the contract acquisition phase. After receiving the letter of commitment, a project manager is appointed to coordinate activities and interaction with the customer, thus beginning the *Project Management* (P10) process. Before the contract implementation, a project kick-off meeting takes place, in order to provide the project-team with the contract information from proposal: scope, schedule, and risk of the contract.

Once the project has been planned and the budget allocated, the *Engineering* (P4) process starts with the design activities. After the successful final design review and the customer design acceptance, the manufacturing and assembly is initiated by the *Strategy and Planning* (P5), the *Supply Chain Management* (P6) and the *Manufacturing* (P7) processes.

The supply of products or outsourced services and the purchasing strategy are managed by *Strategy and Planning* (P5) and *Supply Chain Management* (P6). Manufacturing and assembly (P7) are usually executed on Comau's premises. The production line is then disassembled and shipped to the customer's site where it is installed and fully tested according to acceptance criteria. Activities at the

customer site are grouped under the *Site Management* (P8) process. The overall line realization is validated by means of customer's acceptance and the contract is closed by Project Management (P10). *After Market, Sales & Service* (P15) generally starts after the equipment is on site and provides services and support to the customer.

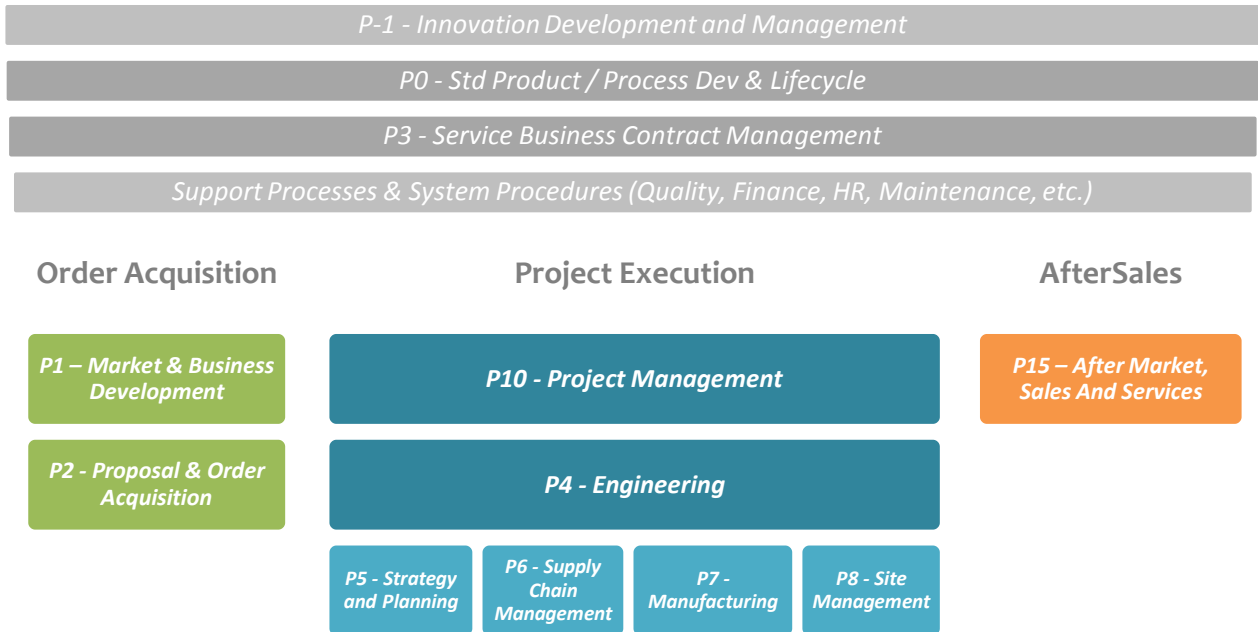

Figure 2: Comau General Processes

Besides, along the projects, Comau Product Lines develop specific products that are proposed to customers (external and internal) and managed by the *Standard Product* (P0) process. Based on market analysis, innovative product development and marketing are planned. These products are treated as a client project up to their delivery, installation and monitoring on the customer's site. On the other hand the more innovation-related activities follows the Innovation (P-1) process. The activities performed following this process are not directly implemented on assembly lines but investigates long term manufacturing trends.

2.2. Powertrain Assembly Systems

Powertrain Assembly and Test (PA) Systems is part of the Powertrain Assembly and Machining Business Unit. Unlike machining processes which are based on metal (chip) removal, assembly processes are based on adding elements to a product to reach its final assembly composition. In parallel with the addition of external components, some tests on the functioning of the product are performed as a quality assurance of the assembly process. The powertrain components of a car guarantee the power generation and transmission that allow the movement of the vehicle. The products defined as part of the powertrain family are shown in Figure 3.

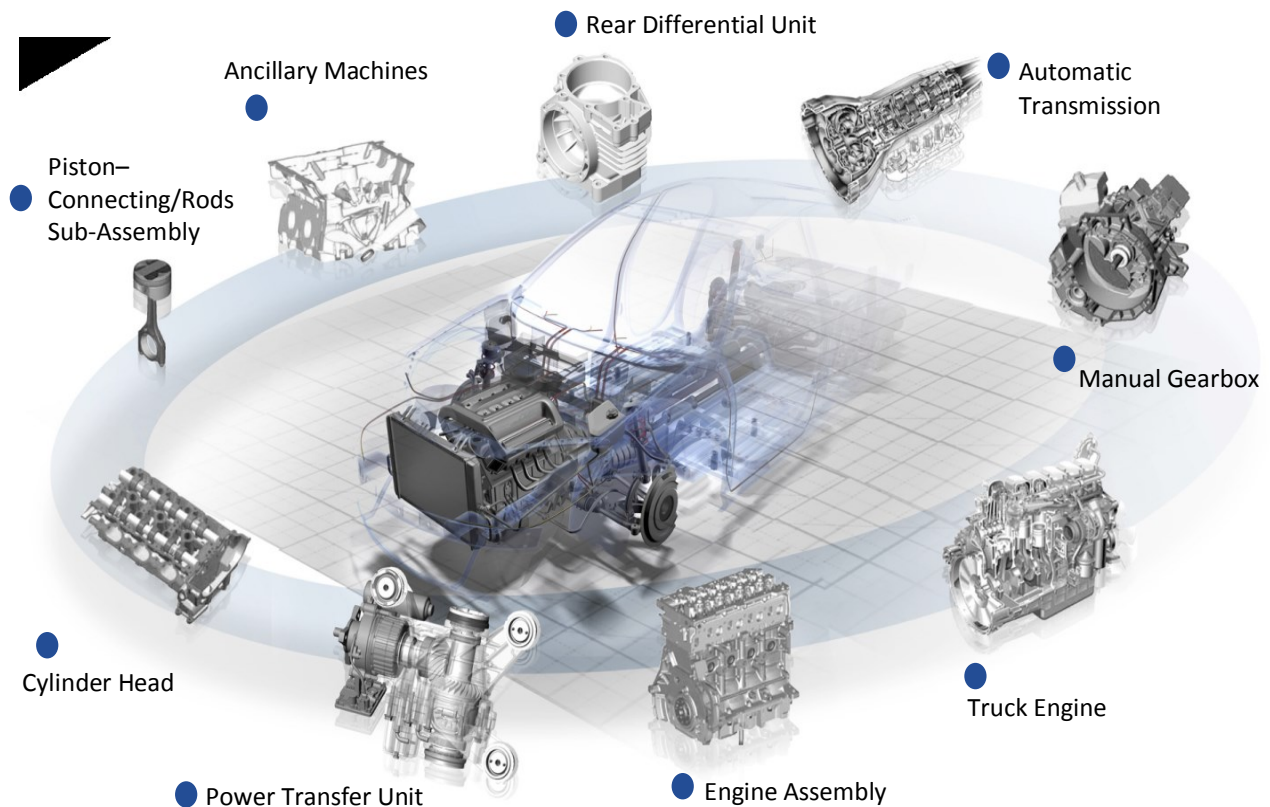

Figure 3: Overview of the product range covered by the "Powertrain" definition (adapted from Comau PA institutional presentation).

Comau has a consolidated competence in the assembly of powertrain components. The main Comau centers of excellence for PA systems are in Italy (Grugliasco), China (Shanghai), Brazil (Belo Horizonte) and USA (Royal Oak, MI), shown in Figure 4.

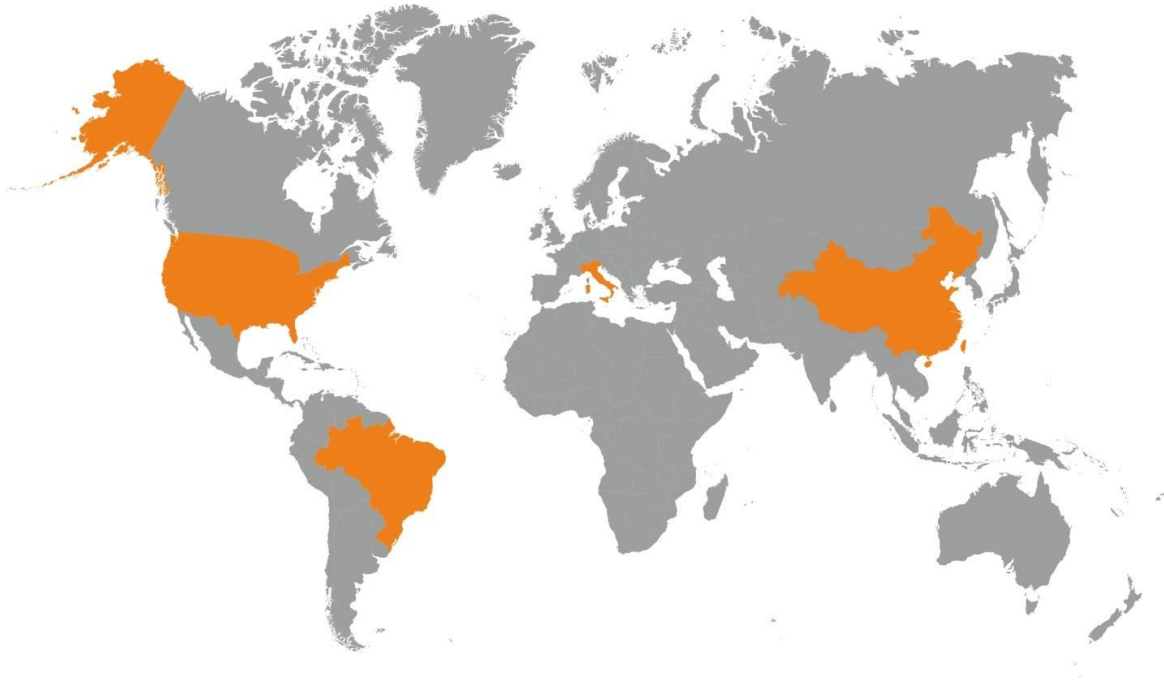

Figure 4: Location of Comau PA centres around the world.

2.2.1. Powertrain Assembly Lines

A powertrain assembly line can be described as a serial process to assemble supplied components into a product (i.e. engine, transmission or suspension). From a physical point of view, an assembly line is composed by a series of workstations that perform serial operations connected by a conveyor system. The product which is being assembled goes from one station to another on top of a pallet carried by the conveyor system. The assembly stations operate independently of each other. Radio Frequency Identification (RFID) tags are installed in each pallet for storing process information associated with the assembly part on the pallet. When the pallet enters the station, it is stopped and lifted from the conveyor which continues to run while the pallet is stopped in the station. Inside the workstation, the assembly process takes place. Once the assembly process is finished, the pallet is released and is conveyed to the next station. Diverters or turns are located at the conveyor intersections to direct pallets to different stations or to change the orientation of the pallet for the subsequent assembly operation. The shape of an assembly line can vary from the simplest shape (i.e. straight line) to a complex layout with loops and turns to develop the line in a constrained existing plant.

One crucial element related to the assembly line is the feedings of the parts that need to be assembled and all the logistics of the plant where the line has to be installed. The production system can be considered as a set of mechatronic components where each device is responsible for a basic operation. Thus the controls architecture of the line is fundamental for its functioning. This includes also all the cables and piping that guarantee electrical, hydraulic and pneumatic supply to the line. The concepts of modularity that will be explained in the next section can equally be applied to the mechanical structure of the workstations and to the control functionality of the components.

2.3.PA R&D and Standard Department

The Standard and R&D department is in charge of process P0 (Figure 2). The main objective of this department is to develop and provide ready-to-sell technical solutions to the proposal and engineering phases. The Standard and R&D department operates in three main directions: (i) it develops standard technical solutions also taking inspiration from past projects and available technical knowledge; (ii) it supports the engineering phase (process P4) of the running projects for the application of standard components; finally, (iii) it investigates future technical solutions focusing on research and development activities.

As mentioned in the previous chapters, technical problems in the powertrain assembly are recurring and often solved with similar but yet different solution. The aim of the Standard and R&D department is to find efficient technical solutions that can be build and customized to satisfy the widest possible range of requirements.

These technical solutions are based on a modular approach to facilitate flexibility and scalability of machines and systems. Modular design in project-based companies allows to divide their development and project functions into specialized groups with clear and distinctive focus, which enables and fosters the development of deep expertise relative to a particular process and its associated components. The same standardization concept is applied both at products (i.e. machines, pallet and conveyors) and processes. The standardization concept applied at processes and equipment allows the so called system modularity.

In the literature, one of the most notable examples of reconfigurable modular automation systems can be found in [13] with an application to automotive powertrain manufacture. The study describe a component-based approach for the configuration of the mechatronic components of the line, able to drastically reduce commissioning times. Reconfigurability is defined as the ability to adjust the production capacity and functionality of a manufacturing system to new circumstances through rearrangement or change of the system's components. The use of fixed configuration, mass production machinery is increasingly seen as being a relatively high-risk option because of the constant threat of obsolescence. Modular production systems although perhaps initially more expensive are more amenable to change and reconfiguration.

Among the advantages of product standardization there is a reduction in the complexity of the technical solutions, a reduction in the supply chain cost due to the improved bargaining power with the suppliers. The reduction of costs is achieved also in terms of less engineering hours (no need to re-engineering something already done). The aim of standardization is also to have better products and more efficient solutions. If products are developed "off-projects" they are usually given more time and focus. The products developed for a specific projects are usually conceived for the specific application following very peculiar customer requirements and may not be reused in the future. The standardization of products can help in anticipating problems before they occur during projects, reducing potential costs and failures.

At the same time, the standardization approach for a typical project-based organization such as Comau poses several challenges related to organizational factors. It is crucial to disseminate the

effort and make available to the system designers the available solutions with all the related documentation to implement a “plug and play” approach.

2.3.1. Process Modularity

One of the aim of the PA Standard and R&D department is to standardize the assembly processes that are recurrent in PA lines. PA covers many fields of application within the automotive sector (Figure 3), thus it deals with a variety of processes. Due to the great variety of processes, the standard department decided to focus on the assembly tasks present in an engine assembly line and in a manual transmission assembly line. These two kinds of assembly lines currently represent the great majority of projects carried out by Comau. All these lines were identified from past Comau projects and grouped together to find commonalities between them and the applied technical solutions.

The result of this data collection and analysis is the definition of ten “Process Clusters”, listed in Table 1. These clusters can be considered as groups of processes that present similar features. This “clusterization” of processes is helpful to underline possible common solutions among processes. For example the gripper mounted on a robot to manipulate the crankshaft and the gripper to manipulate the camshaft could be very similar except for the contact portion (both processes belong to the “insertion” cluster).

Process Clusters
Insertion
Loading
Press
Tightening
Measuring
Marking
Sealant & Lubricate
Rollover
Leak Test
IPV(In Process Verification)

Table 1: Ten Process Clusters that group of all the assembly tasks present in PA lines.

In details the Process Clusters are:

- *Insertion*: processes in which must be inserted some element with a certain level of precision but without the application of press or load.
- *Loading*: movement of elements feeders or temporary stables, often it involves the use of a hoist or a reaction arm, etc.
- *Press*: insertion with interference of an element with a force applied by a pressing system.
- *Tightening*: fastening operations with the application of a torque and, sometimes, also an angle; this process is performed with spindles of different types (ex. Electrical spindle with or without transducers, pneumatic nutrunners, etc.).
- *Measuring*: processes in which, using specific equipment, it is possible to extrapolate punctual data in order to define, for example the thickness of a shim or other components.

- *Marking*: this cluster number 6 concerns those actions acted to sign a certain element. There are different technics that could be used to mark both manual and automatic. These operation are mandatory in case of separation and subsequent reassembly of an element.
- *Sealant & Lubricate*: sealant application and lubrication with oils are two processes that involve different equipment, but they are similar in the application, for this reason they are gathered in the same cluster.
- *Roll-over*: this term identifies generically the action to turn the element from one side to another; in an engine line, for example, there are several kind of roll-over operations: 180° or 90° depending on the side that has to be approached.
- *Leak Test*: specific tests performed, normally with vacuum, to verify the absence of leakage after the assemble of specific components like gaskets, o-ring, etc.
- *IPV (In Process Verification)*: those processes concern the measuring of some parameters in order to validate the effectiveness of the assembly; it is different from cluster 6 because in this case the scope is only to verify that specific parameters fall inside a defined range, while in the measuring process the aim is to select a component depending on a punctual value resulted from the measurement.

Based on these assumptions, there is a need to standardize solutions for all of these process clusters, trying to define station archetypes studied for a common application but that can be scaled to cover varying requirements (e.g. different cycle times).

2.3.2. Equipment Modularity

In parallel with the process analysis, the Standard and R&D department defines the concepts of modularity for equipment of the assembly line. The modularity of equipment includes both the mechanical structures of workstations and conveyors and the controls architecture (i.e. electrical and fluidic). This thesis is indeed more focused on the mechanical side of the assembly line. The modularity of the workstations covers the range of typical assembly stations: from manual stations to semi-automatic and automatic stations. Figure 5 shows an example of modularity of the structure of an automatic workstation (Comau SmartRob). For a complete overview of Comau standard solutions the reader is directed to the technical specifications available at [14].

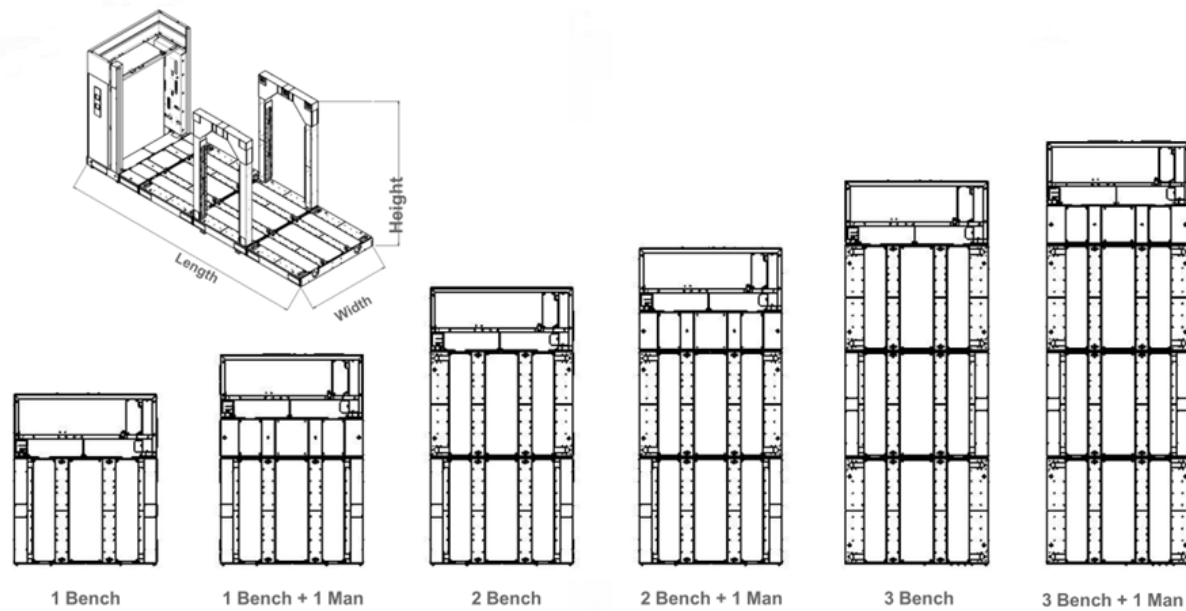

Figure 5: Example of Modularity Concept for an automatic station (Smart Rob)

Unlike the description found in [13] the described research study focuses on the mechanical standardization of production line mechatronic components. The station modularity for manual, semi auto and automatic stations is based on a series of sub-units. Independently from the process performed inside and the type of machine, the “sub-sections” defined are the following:

- *Structure*: indicates the mechanical architecture of the station (e.g. columns, benches, etc.);
- *Standard Support Element*: components that are non-process specific;
- *Process Element*: components of the station dedicated to the specific assembly task.

These three elements are sorted in order of distance from the workpiece being assembled. The structure of the station surrounds all the work area, the standard elements move or hold the process elements that perform the specific assembly task on the workpiece. The definition “Structure” identifies the mechanical structure of the assembly station. The concept of standard structure is quite wider than the only mechanical portion, in fact the stations are already studied to integrate the electric and fluidic equipment needed for any application.

The Standard Support Elements are the objects that are placed on top of the standard structures to hold or move the equipment needed to perform the specific processes. The main peculiar feature of these components is that they are transversal to the defined process clusters. This means that the same standard support element can be applied to different processes. For instance, a six axis robot is considered as a standard support element as they can move a generic end-effector that has to perform a specific process.

The process elements are the components of the station able to perform the specific process. They are strictly connected to the operation they have to perform thus strictly connected to the specific cluster too. An example of process element is a gripper used to take and move the crankshaft from the feeder to its position on the cylinder block, it is designed for the specific task and it could not be applied, for instance, to tighten bolts or to apply the sealant.

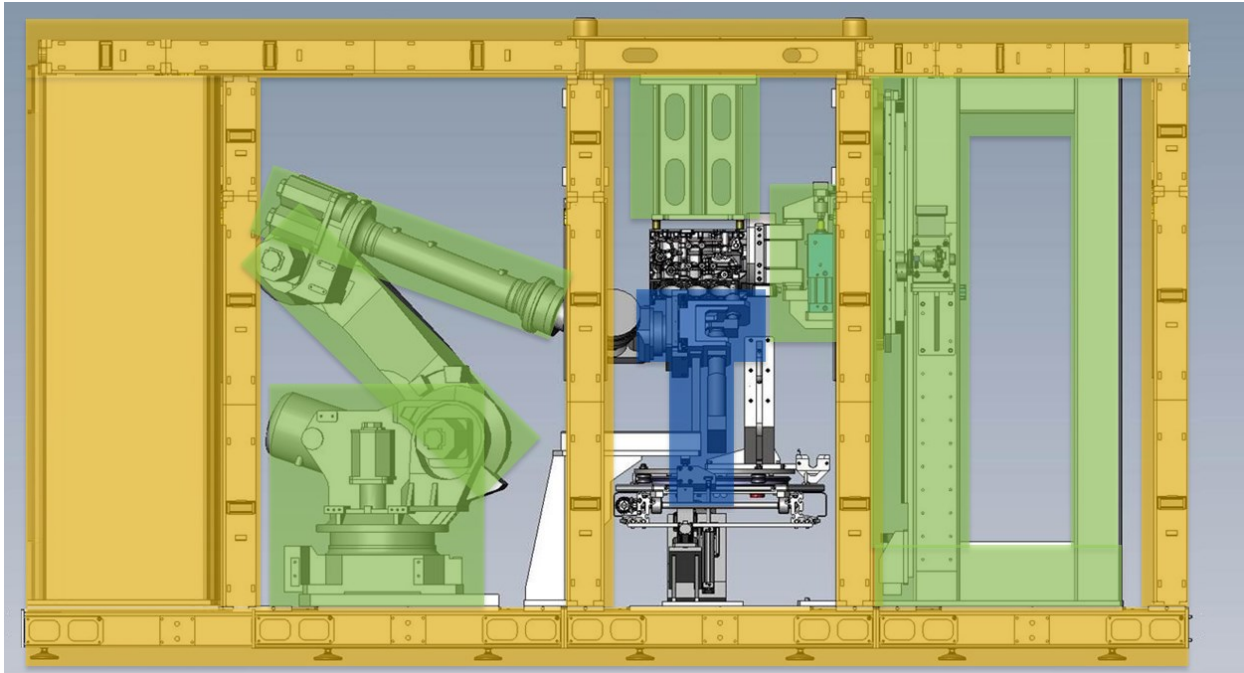

Figure 6: Example of equipment modularity applied to a SmartRob automatic workstation. The components highlighted in orange are part of the structure of the station. The elements highlighted in green are typical standard support components while the blue area indicate a process components.

Figure 6 explains the concept of equipment standardization applied to a SmartRob automatic station. The station structure is highlighted in orange. The standard support elements are highlighted in green while the process specific equipment is highlighted in blue.

In addition to the standard components, during the proposal phase the design engineer has some available solutions of preconfigured stations:

- Carry-over components: where carry-over means solutions taken from past Comau projects.
- Archetype: pre-configured stations used the standard components, useful to perform some of the process clusters.

Due to the very short time given to the proposal and estimation team to produce an offer to submit to the customer, it is impossible to reach, during this phase, a sufficient level of detail in the line definition necessary to ensure the perfect alignment of the costs. For this reason the archetypes are an important part of the standardization process. The use of archetypes is beneficial to the proposal phase as it increases they could catch solutions from a big tank of consolidated processes and equipment; on the same side the estimation team can quote exactly in advance the objects. The more standard components are used during the proposal engineering phase, the more precise the scope of supply will be and thus the relative cost estimation.

Similarly to processes and stations, the standardization effort is directed towards conveyor systems and logistics that are another crucial element of a PA line. Comau PA has two main types of conveyor systems, one based on friction rollers and one chain conveyor. Both conveyors have their features

and ranges of application. The same modularity concepts are equally applied to turns and pallets that covers a wide range of possible applications and processes.

Nevertheless, the standardization process and the development of new products and technical solution are always on-going processes, constantly evolving. The aim of this work is not to give an exhaustive dissertation about the Comau standard products and their technical features but the main aim of this paragraph was to explain the background work of the presented thesis. As a matter of fact, all the work presented in this thesis is based on the described ongoing effort of standardization for powertrain assembly solutions that facilitates the implementation of a KBE configurator approach.

2.4.Proposal Tool and Flow

The focus of this research work is the improvement of efficiency during the Proposal Engineering phase, called “P2 – Proposal & Order Acquisition” according to the Comau Process scheme. The proposal engineering department within Comau can be considered as an “internal customer” of the Standard and R&D department. At the same time, the impact of an efficiency improvement of the P2 process are directly correlated with benefits during the “P4- Engineering” phase which is the internal customer of the P2 process. It is believed that if the output of the proposal phase is robust and consolidated, it can highly improve the detailed engineering phase. The more detailed the first design during the proposal phase, the less efforts will be required by the engineering phase provided that there are appropriate communication and information transfer tools between the two phases. The P2 process is in fact upstream the main Comau project execution. It is therefore a process that is required on a wider range of projects as it is developed for all projects, both the ones that will be acquired and the ones that may be assigned to one of Comau competitors.

Therefore, the proposal engineering is the function in charge of designing a technical solutions to be submitted to the customer. The work of the proposal engineer is strictly correlated with the Standard and R&D department (that provides the readily available technical solutions), the sales departments (that is in direct contact with the customer) and the estimating department (that is in charge of completing the technical proposal with costs). When the proposal is successful and the project starts, the design of the system is handed over to the engineering (P4) for project execution.

In a typical powertrain program, a new engine project starts with strategic planning and market study, which leads to the identification of the product specification and the requirements, volumes, and funds approval. Following the bidding phase the production lines are conceptually designed and manufacturing of lines is started at the machine builders’ sites. Typically about 4 months prior to the completion of the project, the machinery should be dismantled and delivered to the manufacturer sites for final tests and try-out machining. Conventionally the design activities by machine builders take place sequentially beginning with mechanical engineering (i.e. the focus of the presented KBE application) followed by electrical, hydraulic and control engineering activities [6].

As anticipated, the proposal engineering is usually based on a bid phase with different competing providers of manufacturing equipment. There can be mainly four kinds of bid during this phase:

- in the first case (I) the customer has specific requirements made explicit in a document called Request for Quotation (RFQ). The customer already knows in detail the product that will be assembled, the sequence of operations, the level of automation and all specific needs of equipment of the line. The level of detail of the customer specific requirements included into the RFQ is not always the same. Some customers have specific requirements and detailed lists of equipment to be purchased while others leave more freedom to the machine builder.
- In the second case (II) the system configurator company can take part into a “free expression” bid. The information regarding the product to be assembled and the desired technical solution are almost unknown to the system configurator. In this situation, the OEM calls a bid in advance without having precise documentation about the required quotation and invites the providers to participate and advance their proposed solution

- The third case (III) that has to be mentioned is the “retooling”. In this situation the OEM wants to renovate or repair an existing line that has ceased its production. In this environment the system configurator company has to deal with an existing line that may have been installed by a competitor.
- The fourth case (IV) is the case of a “simultaneous engineering” process. The OEM works during some months in close collaboration with a supplier. The requirements during this period constantly evolve and the technical solutions are developed together with the supplier up to the final decision of the customer and the consequent beginning of the project.

These bids are procedures that usually have more than one phase. The different steps of the bid are used by the OEM to slim down the initial list of suppliers. Generally speaking, Figure 7 summarizes the main steps in the proposal flow and identifies the main actors of the process. The equipment manufacturers (i.e. Comau and its competitors) receive from the OEM an RFQ. The Sales department is in direct contact with the customer. The Proposal department is in charge of answering the customer requirements and providing a technical proposal supported by the adequate documentation: technical description of the system and CAD layout with the estimated project costs (set together with the Estimating department).

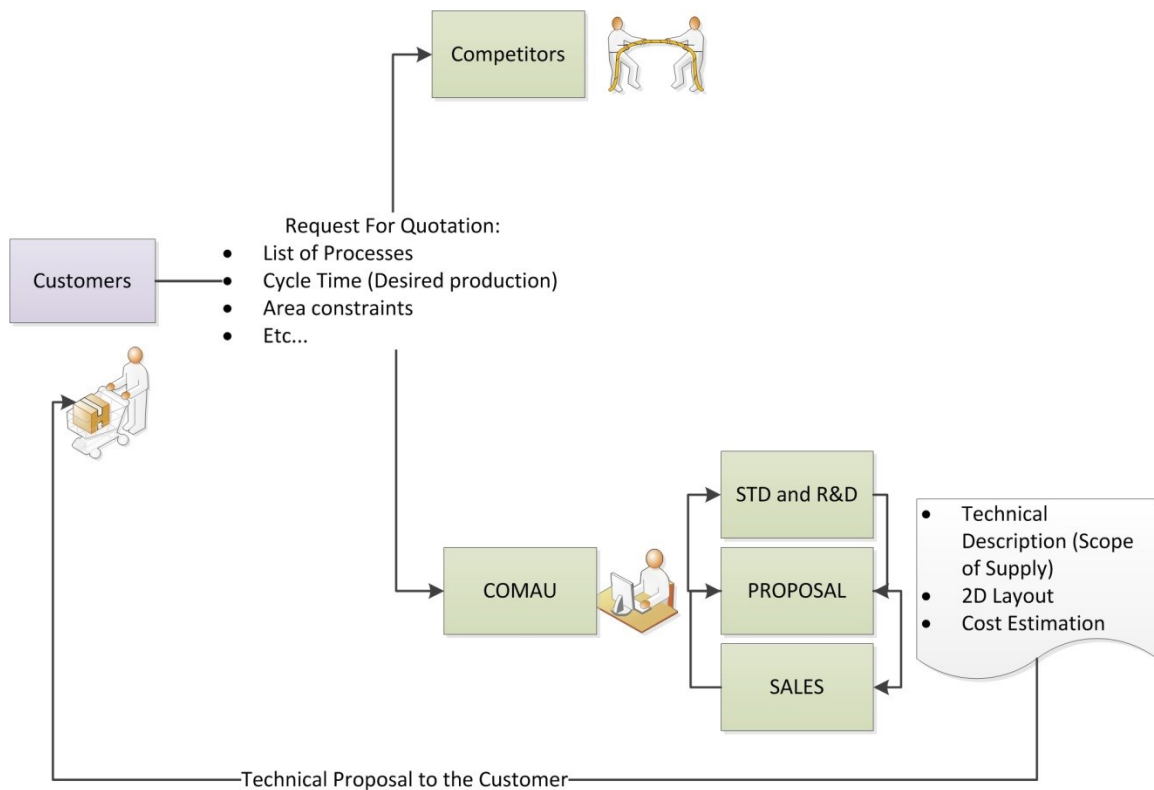

Figure 7: Proposal Flow representation with main actors involved.

2.4.1. Proposal Engineering As-is situation

Data from Comau show, in the last two years, a confirmed trend towards a market expansion in the growing countries. In particular, China and Brazil together represent a great portion of the total

market share of powertrain assembly lines. At the same time, it has been registered a direct correlation between the hours spent for offerings preparation and the number of bids won and started projects (i.e. the so called 'hit rate'). It has been also estimated that every hour spent during the proposal phase generates a fixed project revenue. These data can be used to make some considerations.

- Market opportunities in emerging countries are expanding. Brazil and China have currently a lack of trained workforce. This shortage of resources may affect negatively the business. It is crucial to extract, transfer and make globally available existing knowledge to improve effectiveness in the proposal phase. It is estimated that 20%-40% of the production was carried out in production plants owned by globally operating companies in 2005 [35], with the trend being declining.
- The margins for hit rates improvement are high. Given the direct correlation between hours spent during the preliminary design phase and won contracts, it would be beneficial to have a tool to support the proposal, reducing times. Knowledge in design is a key factor, considering that, for instance, over 60% of design tasks are common between past and new engineering projects. [36]
- The industrial automation market is highly volatile. Given the current resources and skills, a tool to improve efficiency in the preliminary design phase can increase the number of presented proposals and, consequently, won contracts.

From a business process point of view, the problem to be solved is the inefficiency during the proposal design phase. Many opportunities of the market are not exploited due to these inefficiencies. Part of these lost opportunities are not tackled due to shortage of time and resources, and part because of poor design or too high cost.

Even when the bid is successful and the project starts there might be some design inefficiencies. These inefficiencies are propagated downstream Comau processes and strongly influence the detailed engineering phase. Sometimes this proposal inefficiencies are due to the lack of a common approach in the different countries by the same equipment provider company. There is a high probability that the same design requirements given to different designers all over the world will lead to different outputs. This increases variety but introduces a high complexity and is an obstacle for the re-use of existing technical solutions. In fact, from a technical/design point of view design techniques and rules behind the configuration of an assembly systems are part of the tacit knowledge of the designers. Moreover the design process is made up of several steps hardly integrated and many time consuming and repetitive tasks that could be automated.

Therefore the objective of this research study is to improve the as-is situation by increasing the efficiency of the preliminary design of powertrain assembly systems, to reduce mistakes and shorten design times. This will be done leveraging the existing technical knowledge of experienced designers and engineers.

3. State of the Art – Knowledge Based Engineering

Abstract

The design of assembly lines is a largely experience-based activity. It is estimated that almost 60% of design tasks are common between past and new engineering projects. Many authors have investigated approaches to automate the design reducing repetitive and time-consuming tasks. One of these approaches is Knowledge Based Engineering (KBE) that represents a merging of object oriented programming (OOP), Artificial Intelligence (AI) techniques and computer-aided design (CAD) technologies to support knowledge re-use in engineering companies. KBE in the literature is largely applied to product configuration tasks with only few applications to manufacturing systems. Despite being firstly developed in the 1980s, KBE at an industrial level still lacks of a widespread validation and application. This chapter reviews the existing scientific literature in the fields of manufacturing systems design engineering with particular consideration for KBE and design automation.

3.1.Engineering Design

The mechanical design of a product consists in the solution of a design problem from the assignment to the final product design [15]. One of the most cited model in literature about product design has been developed by Pahl and Beitz [9]. This process model subdivides the design process into four main phases:

- Planning and task clarification;
- Conceptual design;
- Embodiment design;
- Detail design;

This work focuses on the embodiment design, the phase in which the designer defines rough arrangements and structural dimensions of the product in accordance with technical, economic and aesthetic considerations. In this thesis we speak of a specific feature of design activities, namely “configuration”. In fact, the preliminary design of powertrain assembly lines does not strictly follow the traditional design model but it is more comparable to a configuration process. On the contrary, mechanical design is an activity assigned to the R&D Standard department which is in charge of developing standard and modular solutions that are then used by the proposal engineer for the layout configuration.

The modern concept of mass customization and the increasing complexity of customer demands has given rise to new engineering design techniques that are now widely accepted and used. The method and application of product platform design has been described by Simpson et al. [16]. In the practice of engineering design, modular approach to the design of products [17] is the solution for generating a number of product variants. The modular design of PA lines embraces the concept of generating a high number of possible configurations using a set of limited modules.

3.1.1. Assembly Line Design

At a company level, the design of a new production line does not start from scratch. Based on the requirements of the customers, engineers use their own knowledge and try to recall past layout ideas usually employed as a basis for the design of the new production line. According to Efthymiou [1], around 20% of the designer’s time is dedicated to searching and analyzing past available knowledge, while 40% of the information required for a design is identified through personally stored information, although other sources of information may be more reliable. Other authors have also investigated the efforts of the design engineers to look for existing design knowledge [18-20]. A lot of knowledge is, in fact, already stored, and has been used for a long time and evolved over time. Knowledge in design is a key factor, considering that, for instance, over 60% of design tasks are common between past and new engineering projects [21].

For this purpose, there is a pressing need to retrieve the existing technical knowledge and integrate it into a common and reachable framework [6]. Capturing and reusing engineering knowledge has proven to be very difficult. These activities usually require users to be able to develop computer codes to embody knowledge rules and actions, and do not integrate common product design tools, such as CAD, CAE, and PLM/PDM systems. Configurator approaches for automating design activities

are suitable for low-complexity products, but are difficult to be developed for medium/high complexity products such as an assembly line.

The design of production lines is a complicated task that presents a huge variability of inputs and outputs. Almost and infinite number of different technical solutions can satisfy the same set of requirements.

Automotive is the leading sector in the global automation market, accounting for a 35% of the total market size . The automotive industry was, alongside the aerospace industry, the main driver of KBE [22]. However, of all the works in the existing literature targeting KBE in the automotive sector, only a few studies are specifically focused on the design of manufacturing system. Two main examples of KBE applications for the automotive industry are: ProcesoStudio, used for seat configuration, and process planning for die design, a critical task for the quality of the Body-in-White (BiW) [22]. Naranje and Kumar [23] also investigated a system combining artificial intelligence and CAD for die design with possible applications in a range of different industries. Automotive is considered to be a mature sector but still with areas of improvement in the overall product lifecycle. In particular, regarding assembly systems design there is a lack of well-developed engineering techniques, as highlighted by several studies [6].

Inman et al. pointed out the correlation in the automotive industry between production system design, defined as everything that happens before manufacturing, and quality of the products in output [24]. During the design of a production system it is important to take into account several factors that impact on the quality of the final product such as plant layout, line speed, modularity, and level of automation. Regarding the application of knowledge based framework to the design of production lines, Colledani et al. presented an approach for the early stage design of automotive body assembly line [25]. The presented approach is based on analytical performance evaluation models, able to reduce design time. Qattawi et al. developed a methodology based on quality function deployment (QFD) and analytical hierarchy process (AHP) for the development of a BiW panels production line considering production requirements and process attributes [26]. Papakostas proposed an approach, in the form of a rule-based model, capable of generating process design alternatives for automotive BiW robotized assembly cell [27]. Raza and Harrison focused their attention on powertrain assembly lines and especially on the need for a company to adapt and reconfigure a production line following product modifications [28]. Haq [6] and Harrison [29] proposed a new vision for the automotive powertrain assembly systems by redesigning the interactions between engineering actors according to company requirements made available at Ford Motor Company.

This work is focused on a preliminary design phase of a powertrain assembly line in Comau and tries to use the increased modularity of assembly systems to speed up the configuration process.

Early decisions can determine almost 80% of the product costs (determined costs), at a stage where knowledge about the product, customer and the processes involved is low or vague, and the actual development costs (incurred costs) are low [30]. For this reason it is important to improve the quality of early stage decisions building them on a shared knowledge base and on past experiences. The diagram show in Figure 8 proposed by Ullman [31] demonstrates how product costs are typically

committed during the early phase of the design. On the contrary, cost incurred is the amount of money spent on the design of the product.

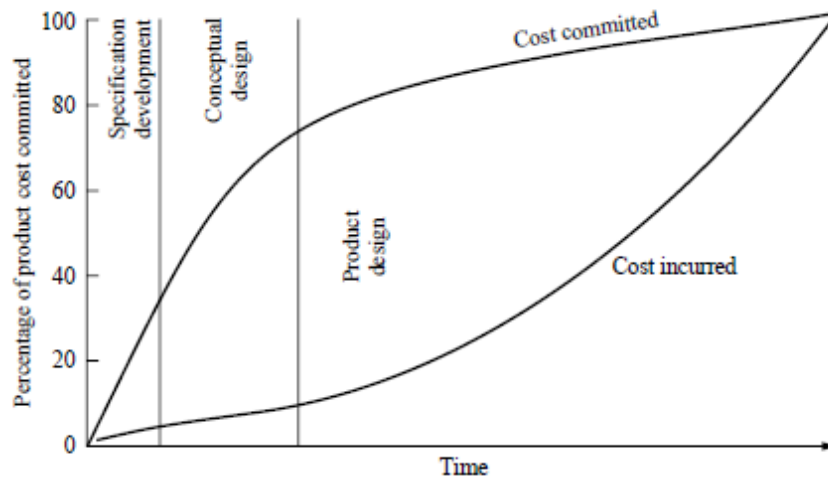

Figure 8: Manufacturing cost commitment during design (taken from [31]).

3.2. Knowledge Technologies and KBE systems

3.2.1. KBE definition

KBE is an engineering method that represents a merging of object oriented programming (OOP), Artificial Intelligence (AI) techniques and computer-aided design (CAD) technologies, giving benefit to customised or variant design automation solutions. The KBE systems aim to capture product and process information in such a way as to allow businesses to model engineering design processes, and then use the model to automate all or part of the process [32]. One of the most cited review of KBE [33] in the literature sees KBE as positioned in the group of the so called knowledge technologies. The power of knowledge technologies comes from the way they combine ideas and applications from a surprising broad and heterogeneous set of fields, including psychology, philosophy, artificial intelligence, engineering, business management, computer science and web technologies. The development of computer systems that help engineers to increase the efficiency of their work by enhancing the level of automation in the design process, is definitely the area of interest of KBE. Therefore, KBE has not a unique definition but the various definitions found in the literature reflect the different views of the user. A company manager can see KBE as a technology asset to compress product development time and cut engineering costs. A KBE developer, i.e. the user of a KBE system for the development of KBE applications, sees it as a refined type of software development tool incorporating aspects of object oriented (OO) and functional programming. Engineers and designers, i.e. the typical users of KBE applications, might see KBE as a technology to augment the dynamic calculation capabilities of classical spreadsheets with generative geometry and report-writing capabilities, or, vice versa, to augment the level of automation and “intelligence” of conventional CAD systems by embedding design rules and engineering knowledge. Eventually, engineers would see KBE as a technology that can support their work better than other conventional IT technologies (e.g., spreadsheets and CAD) through the automation of routine design tasks and easier implementation of multidisciplinary design optimization (MDO) methodology. According to La Rocca, KBE is all of this, which leads to this extended definition [34]:

Knowledge based engineering (KBE) is a technology based on the use of dedicated software tools called KBE systems, which are able to capture and systematically reuse product and process engineering knowledge, with the final goal of reducing time and costs of product development by means of the following:

- *Automation of repetitive and non-creative design tasks;*
- *Support of multidisciplinary design optimization in all the phases of the design process.*

3.2.2. KBE History

The idea of KBE developed first in the 1980s when one of the most influential trends in the industry was Artificial Intelligence. Despite this, KBE has not had the same success as CAD systems and had a significant evolution only in the last 15-20 years for some reasons that La Rocca identifies in: high cost, low accessibility level, few literature, case studies and metrics and lack of a clear methodology [33]. For nearly 20 years in fact, KBE has been used mainly in big automotive and aerospace industries, one of them being Boeing. However, no one realized the early promise of KBE in practice in those 20 years, since fully functioned KBE was missing even in the aerospace world where it has its highest impact. In the beginning, companies such as ICAD, Wisdom systems encouraged the research

and developed the special purpose AI hardware such as Symbolics Lisp machines. However extremely high cost hardware became a barrier for widespread of the technology. Further, these developed systems geared towards expert systems. Later, with the support of independent software vendors KBE came down to approachable cost. Many of the KBE systems were integrated in existing CAD tools improving their diffusion.

Nowadays there are state-of-the-art commercial tool on the market that integrate KBE aspects with CAD capabilities and configuration tools to support sales processes. In spite of the not always orthodox KBE nature of many of the new tools on the market and the questionable absorption processes carried by the big PLM companies, there are some incontestably positive consequences on the diffusion of KBE such as the reduction of costs and increased marketing capabilities [33]. Figure 45 in section 5.7.3 shows an overview of the KBE vendors and an evolution of KBE languages and software packages.

3.2.3. KBE literature and related fields

As we already anticipated, KBE is a transversal discipline that takes aspects from different fields of study. Here we try to mention some of the most relevant scientific work that include KBE with KM, DA, and some applications.

KBE and KM

There is a huge number of scientific works in the field of knowledge management (KM). An extensive review of knowledge representation and practices in generic design problems can be found in Chandrasegaran et al. [35]. Lee and Chen in 2012 analysed a large dataset of more than 10000 publications in the area from 1995 to 2010 [36]. The key finding of their study is that the coverage of KM works has expanded to a broad range of disciplines, from business, to software engineering, to machine learning.

KBE and Design Automation

Some of these publications in the literature deal specifically with the themes of DA and KBE, and have tackled DA with applications in mostly repetitive tasks and routine work. Kusiak and Salustri [8] provide a review of the experimental applications of computational intelligence to the product conceptual design phase. Cederfeldt points out the requirements that a DA system should meet: low effort of developing, low level of investment, user readable and understandable knowledge, transparency, scalability, flexibility, longevity and ease of use [37]. Vermeulen developed an automated detailed design tool for fuselage engineering, combining KBE approach and DA [38].

KBE and CAD

KBE systems are strongly related with CAD software tools and they evolved over time consequently. Many different taxonomies of KBE systems can be found in the literature but for the purpose of the work it is interesting to classify KBE system according to their independence level with CAD tools:

- Self sufficient: the CAD system is integrated with the KBE kernel, so there's no need of additional software to work;
- Embedded: the KBE system is a plug-in of CAD software;
- Integrated: the KBE system works independent from the CAD software;

In the first years KBE systems with their capabilities of manipulating geometries, were created with the aim of complementing a missing aspect of CAD tools . Although, CAD and KBE do share some capabilities, they have a fundamentally different focus: CAD systems focus on geometry. KBE systems focus on rule capture and knowledge, with geometry merely being one of the many kinds of inputs that can be passed in and outputs that can be generated.

KBE Methodologies and Applications

In general, the works targeting only KBE are relatively dispersed. One of the most cited example of research activities in the KBE field is project MOKA (Methodology and tools Oriented to Knowledge based engineering Applications) [39]. Chapman et al. [40] reviewed the main KBE techniques and provided indications of the possible benefits to companies. Similarly, Verhagen et al. reviewed KBE methodologies and theoretical foundations analyzing more than 50 research contributions [2]. They provide also some guidelines for further research including the necessity for improved methodological adherence and the need for a quantitative framework to assess the viability and success of KBE development projects. However, KBE is a field still in development, with methodological and technological considerations constantly evolving.

Sanya and Shehab pointed out that the future generation of KBE systems will adopt a platform-independent approach [41]. This will ensure the key knowledge required for a KBE system is created independently of the KBE implementation, increasing abstraction and reusability of engineering knowledge. For this purpose, ontology-based approaches for modelling the design parameters and design rules for KBE systems are also employed, using ontology editors such as Protégé [42, 43]. Ontology and database can have a certain degree of complementarity [44]. Examples of ontologies applied to describe manufacturing concepts can be found in Kim et al. [45] and in Efthymiou et al. [46]. Furthermore, Ma and Liu have identified that many applications of KBE systems are usually domain specific and ad hoc solutions designed for solving specific design challenges [47]. Further discussions in the literature have highlighted the shortcomings regarding the maintenance and excessive cost of managing several KBE applications and integrating them with other Information Technology (IT) applications [48].

Regarding the collection and re-use of project memories, Monticolo et al. developed a multi-agent system called KATRAS able to collect different types of knowledge from different actors involved in engineering activities [49]. Mourtzis and Doukas investigated ways to tackle the same problem with a case study in the mould making industry [50]. Efthymiou et al. investigated knowledge reuse applied to the configuration of production systems, presenting a knowledge framework for supporting the early design of a generic manufacturing line [51]. This approach, based on semantic technologies with the use of ontologies, is part of a greater framework called Virtual Factory Framework (VFF), which explored the use of Virtual Reality techniques in different manufacturing applications [52]. Efthymiou et al. describe the knowledge framework module used to support the early design phase of manufacturing systems leveraging past project based on the semantic technology and similarity measures, with a case study on the production of H beams [1].

Regardless the existing literature, knowledge gaps remain concerning the application in an industrial domain and all the cited research works lack of a clear industrial validation. As a matter of fact,

despite the developments in design automation systems, there is no consolidated implementation in an industrial environment to support the day-to-day work of designers and engineers.

4. Research Methodology

Abstract

The overall objective of this thesis is to introduce a new approach based on a knowledge based configuration system for assembly line design. The KBE methodology used is taken from the literature and adapted with the addition of an evaluation step. The methodology consists of six steps: (i) specs. definition, (ii) knowledge acquisition, (iii) knowledge formalization, (iv) knowledge implementation, (v) knowledge integration and finally (vi) evaluation. Knowledge about assembly lines and the design process is collected, formalized in a computer readable format, implemented in the software application and integrated with other engineering tools (e.g. CAD). Finally the developed configurator application is tested and evaluated by the same designers and engineers.

4.1.High-Level Architecture of the Study

As anticipated, the present study is based in an industrial context. The research starts from a critical business need concerning the efficiency of the proposal design phase of complex systems. Therefore the study deep dives into the industrial needs and proposes a methodology based on the existing literature for tackling the highlighted issues. The proposed methodology is applied to a specific case study to build a KBE application for the configuration of PA lines. The test and evaluation phase plays a crucial role in the architecture of the study as it used to validate the approach and asses the benefits. The evaluation of the possible benefits confronted with the costs is a preliminary analysis to verify the efficiency of the solution proposed. The overall logical architecture of the study is presented in Figure 9.

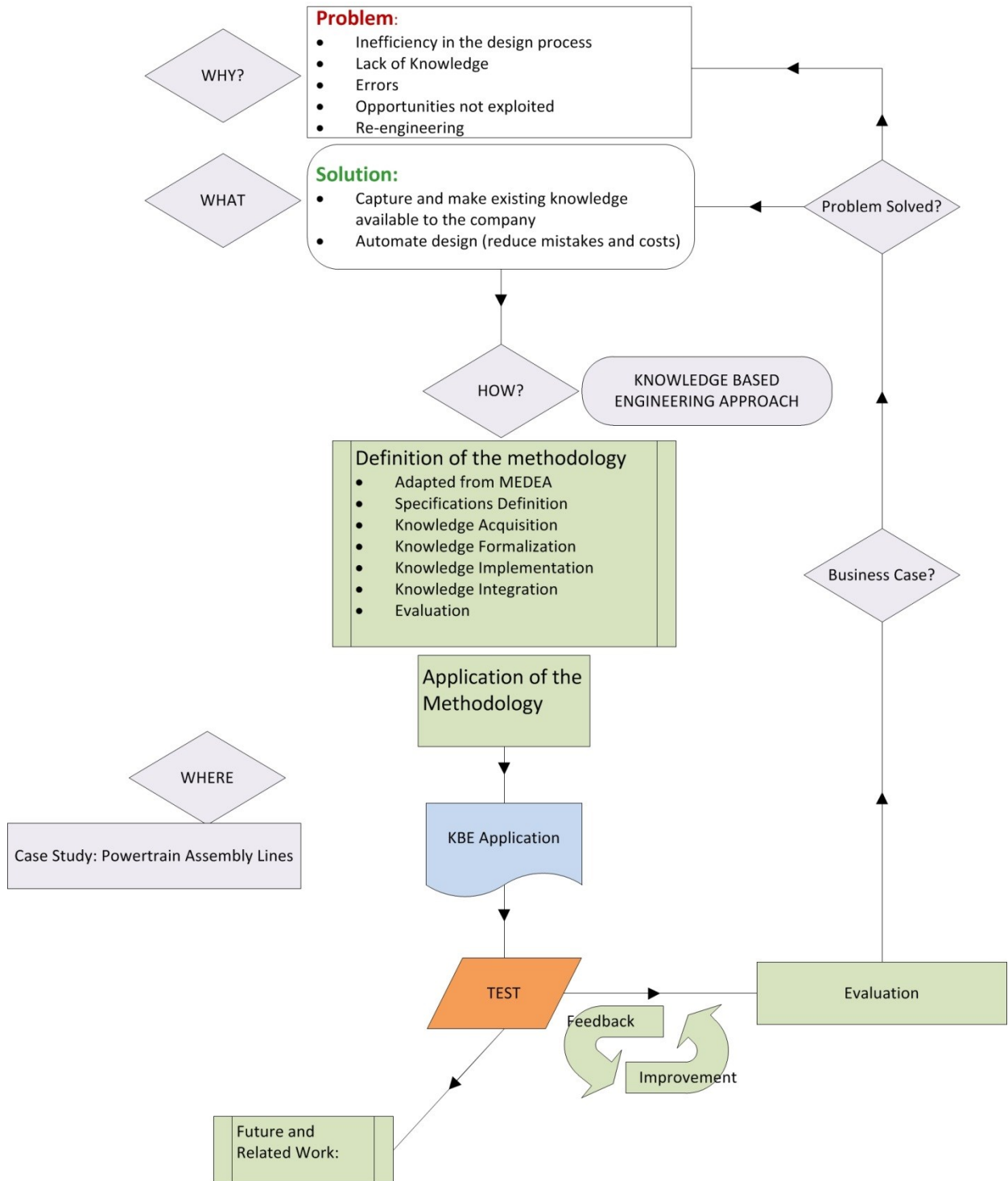

Figure 9: Logical Architecture of the research study

4.2. Methodology

A methodology is essentially a set of instructions and guidelines on how to perform a complex procedure. It details the individual sub-tasks, how they should be carried out, in what order, and

how the work should be documented [53]. Furthermore, it might be thought that the time and effort required to do so would be better spent developing the application itself. However, the use of a methodology is not simply beneficial but it is vital for the quality, reusability and maintainability of the delivered system.

4.2.1. Existing Methodologies

Different methodologies have been published for KBE system development. However there is no recognized dominant methodology that is widely accepted for this kind of applications. This may be a significant factor in the relatively slow uptake of the technology. Perhaps the most cited and discussed methodology for building knowledge based systems is CommonKADS [54]. It describes knowledge based systems development both from a project management perspective and a results perspective. CommonKADS provides the methods to perform a detailed analysis of knowledge-intensive tasks and processes. It also allows a clear link to modern object-oriented development and uses notations compatible with UML. On the other hand MOKA [39] is a project that aims to produce a KBE system development methodology that will form the basis of a new international standard. The methodology is particularly aimed at capturing and applying knowledge within aeronautical and automotive industries of the design of complex mechanical products. Both these methodology are recognized to be by the scientific community the most relevant in the field of knowledge based systems. However these methodologies are sometimes too complex and have a steep learning curve that reduces the uptake and diffusion of KBE experiences in companies of different sizes. Therefore the presented methodology is based on simpler procedure targeted at smaller companies and that does not dictates the use of specific software packages or languages.

4.2.2. Proposed Methodology

The present study is inspired by the Methodology for Design Automation (MEDEA) presented by Colombo, Rizzi and Pugliese [55] and used for some applications [56]. MEDEA proposes a step by step roadmap to develop implement DA into Small Medium Enterprises (SMEs). KBE approach is considered by the authors to be the best way to implement DA in an industrial context. In the cited paper, the MEDEA methodology is validated through 2 different case studies. However no evaluation of the methodology is presented. Hence, this work tackles the problem with a different approach. This research presents a new methodology that: (I) adds to the existing MEDEA roadmap an evaluation step which is considered to be crucial for achieving the industrial acceptance of the implemented approach; (II) is shared and tested in the same industrial environment; (III) specifically targets the preliminary configuration of production lines based on existing knowledge and not the design of a product; (IV) it aims not only at modifying the CAD model of the product but it integrates more software tools for a complete output, from 2D and 3D layout, to the optimization of the line and the technical description.

Nevertheless, one of the typical output of the engineering phase of an assembly line is the Discrete Event Simulation (DES). Indeed, this analysis allows the system engineer to estimate the line efficiency and production output on long time horizons (i.e. usually from one month to a couple of years). There are specific software tools that allow this kind of study. DES software tools and their application will be further discussed in 6.2. One of the requirements of our roadmap is the integration of a DES analysis during the preliminary design phase of the assembly line, on the basis of the created layout. The (IV) integration of KBE with DES software programme is a theme not fully

explored in the literature of typical *product-related* KBE applications and an another difference with the existing MEDEA methodology. However, at current state of development, the use of the simulation by the KBE application is not yet fully implemented because of some programming issues regarding the integration of the different programs.

Therefore, the presented methodology is divided into six steps, shown in Figure 10. The steps 2 and 3 are grouped together being the most *knowledge intensive* phases where configuration rules are defined by the knowledge engineer in close collaborations with the designers and engineers. Similarly, steps 4 and 5 are clustered together as they are the phases in which programming skills are required and the integration between the different software tools is achieved. The differences from the MEDEA methodology are summarised in Table 2.

1. *Specifications Definition*. The first phase is crucial to define the objectives of the KBE application, find sponsors and establish managerial commitment.
2. *Knowledge Acquisition*. It is demonstrated that a process, which is believed to have a relevant component of explicit and tacit knowledge, can be mapped with different techniques of Knowledge Acquisition (KA). KA is considered the most time-consuming process and the bottleneck in constructing a knowledge-based system [57, 58]. This acquisition process requires the competences of a professional figure, relatively new to companies, usually called knowledge engineer. During the KA phase, the knowledge engineer characterizes important aspects of the problem and identifies participants, resources and goals.
3. *Knowledge Formalization*. During this phase key concepts and relations are made explicit [8]. Unstructured knowledge is formalized in a computer based format and tacit and implicit knowledge are mapped into the form of basic rules that can be managed by a software program.
4. *Knowledge Integration*. During this phase the integration of the KBE application with other design tools is discussed and the overall system architecture is defined according to the formalized knowledge. The application should be interfaced with PDM/PLM as well as with CAD systems.
5. *Knowledge Implementation*. During this phase the KBE application is developed by the software engineer according to the formalized knowledge.
6. *Evaluation*. The evaluation phase was explicitly required to test the applicability of the KBE approach in a real industrial environment and to substantiate a solid business case.

In chapter 5 each of the listed step contains more specific indications about the methods used for the research and procedures, including tools, data processing and test beds.

The choice of the methodology was driven by the background work considering the literature state of the art of DA and KBE methodologies. Given the starting conditions the activity has the features of a configurator tool. Hence, the modular approach of the PA standard products is used as the basis for the line configurator. The single modules of the assembly line (i.e. stations, conveyors, etc.) have relationships with each other that are defined by the configuration rules. These rules, often implicit, have to be extracted during the knowledge acquisition phase.

The modular approach is used both for the configuration of the line and for the design of the KBE application. The KBE application is aimed at a modular structure where the main part of the application is the rule manager. This software is integrated with other software tools commonly used during the preliminary design phase. Therefore, each integration represents a specific module of the KBE application with a defined output. For instance, the *CAD module* integrates the kernel of the application with a CAD software program to generate the layout of the line, while the *Balancing module* integrates with MATLAB to have in output the balanced sequence of the line. This concept will be better explained in section 5.4.1.

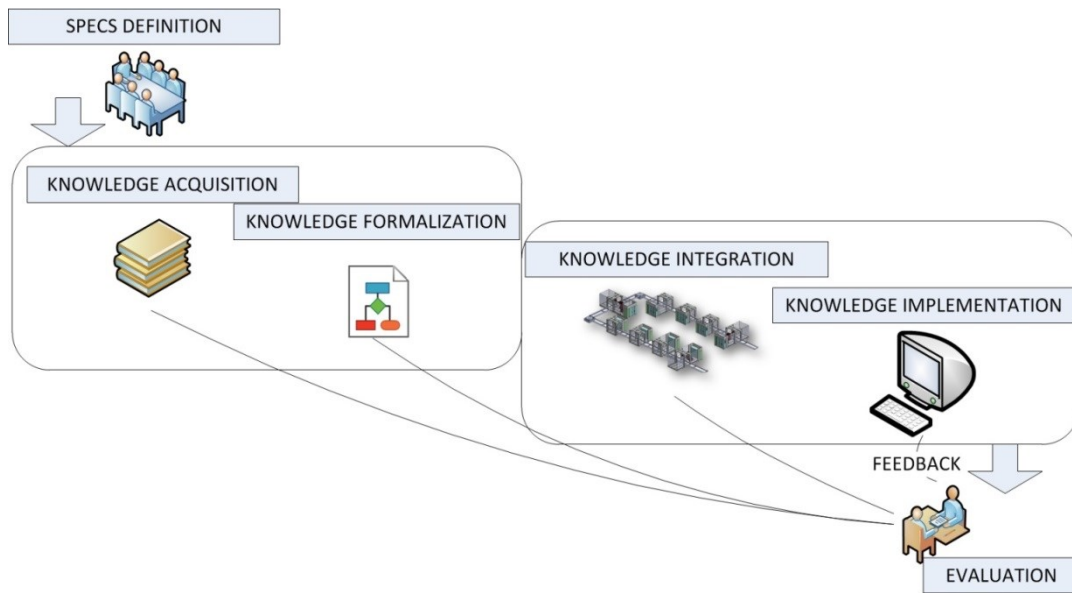

Figure 10: Six-step methodology for development of KBE industrial applications

Table 2: Difference between MEDEA and the presented approach.

	MEDEA	Presented Approach
1 Specs Definition	-	-
2 Knowledge Acquisition	Limited to the design and the knowledge about the product	The scope of the methodology is extended to a production line, not only for product design
3 Knowledge Formalization		
4 Integration		The integration of the tool is expanded. The KBE application is aimed not only at modifying the geometrical prototype of a product but it integrates engineering tools to generate a 2D Layout, 3D Layout and a technical description of the line (including quotation). The integration with a DES tool is an aspect missing in traditional product-related KBE applications.
5 Implementation	-	-
6 Evaluation		The evaluation step is new to the methodology as it is considered to be crucial for industrial implementation of the system.

4.2.3. Proposal Engineering – To Be situation after KBE implementation

The implementation of the proposed methodology will achieve a situation in which a KBE software package is available to the designers for an automatic configuration of an assembly line. The KBE software tool will be based on the knowledge acquired through the process. The customer is connected with the proposal department to which he forwards the complete RFQ; nevertheless in the future the customer should be able to access directly the *online* system configurator. After that, the proposal engineer interacts with the developed application through a graphical user interface (GUI) and the software application produces the desired output. After the project has been acquired it is expected that a feedback mechanism from the running plant should be implemented to improve the design phase. The overall architecture of the knowledge based framework is shown in Figure 11. Figure 11 shows after the of the output of the KBE application the generation of a feedback from the field. This particular features refers to the opportunity to gather data from the subsequent project steps (i.e. manufacturing, commissioning, etc.). These data could be used to enrich the rules database and improve the design phase. This feature is part of the overall architecture of the KBE methodology but it was not tackled by this study.

Research Methodology - Methodology

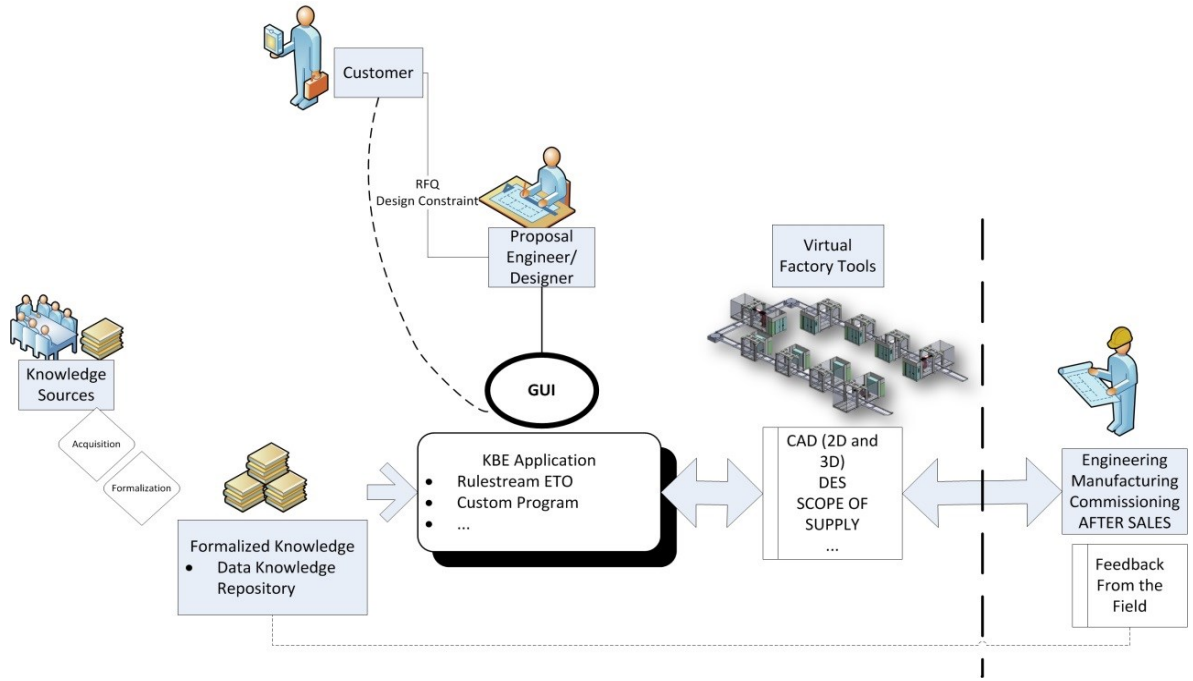

Figure 11: Overall architecture of the knowledge framework to be implemented.

5. Application

Abstract

The methodology presented in Chapter 5 is applied to the industrial scenario. The knowledge engineer, in close contact with proposal designers and engineers and exploiting different acquisition techniques collects and formalize knowledge about the assembly line and its design process including configuration rules (e.g. line balancing, layout design, etc.). The formalized knowledge is implemented in the KBE application integrated with a document generator for the line description output and a CAD tool for generating the 2D and 3D line layout. Finally the application is tested on the configuration on a cylinder head assembly line and evaluated quantitatively and qualitatively based on some parameters such as lead time reduction and resources utilization.

5.1. Specification Definition

The specifications of the KBE application are defined by the engineering company and taken as starting point for the research. The main aspects of the specifications are:

Goal (design outputs). The focus of the engineering company is on the output of the research. There is a pressing need to capitalize on existing technical knowledge within the company and to automate as much as possible internal design activities. The output required is a quick and ready-to-implement methodology to build KBE applications and an evaluation of the positive impacts on design performances. Therefore, in this work the output is not only the development of the methodology and its application, but also an evaluation of the possible benefits deriving from the implementation of the approach in the industrial environment.

Sponsors/Managerial Commitment. In this preliminary phase specifications from the company are elicited and the management expresses its commitment and support to the research activity. In this case, the managerial commitment has been elicited since the beginning. One of the improvement objectives of the company is to improve engineering performances reaching the *zero targets*: (i) zero delays, reducing design times taken by repetitive tasks; (ii) zero mistakes, reducing errors by automating design; (iii) zero complaints, better understanding and sharing of the solutions with the customer from the initial design phases.

Resources/Time. The company involved in the study is concerned with the use of existing resources for the implementation of a KBE application. One of the specification was the analysis of the required skills and resources needed to implement and generalize the construction of KBE applications. The company made available all the necessary resources for the development of the research study. This type of KBE applications are usually developed thanks to the help of a professional figure new to traditional company architectures, the so called knowledge engineer that will be better introduced in section 5.1.1.

Level of Detail. During the specifications definition it is important to define the level of detail of the desired application. In all knowledge acquisition projects the level of detail is crucial to establish the level of effort needed to successfully achieve the goal. In this case a powertrain assembly line can be mapped from the high level components down to the single screw. Clearly a higher level of detail requires an increased effort in terms of time and resources. For this specific application it was chosen to deal with *high level modules* that compose the assembly line. This level of detail is considered to be adapt to the early design process of an assembly line where it is anyhow impossible to define rules down to the single equipment of the workstation. The resulting high level architecture of the line will be better explained in the next section.

Case Study/Demonstrator. In this first phase, the case study for the KBE application is defined. In our methodology the first case study (i.e. *α case study*) is restricted to a relatively simple aspect of the engine assembly, namely cylinder head valve train assembly described in section 5.1.2. We defined as *β case study* the same scenario with modified initial specifications from the customer. All the methodology has been applied to the cylinder head assembly. Generally speaking, engines and transmissions are consolidated products that have a relatively well-known manufacturing and

assembly sequence, thus in future work the application will be expanded to other assembly processes in the field.

5.1.1. Resources – Knowledge Engineer

In this phase we introduce the figure of the knowledge engineer. A knowledge engineer is a professional engaged in the science of building advanced logic into computer systems in order to try to simulate human decision-making and high-level cognitive tasks. A knowledge engineer supplies some or all of the "knowledge" that is eventually built into the technology. The knowledge engineer leads the whole process of the implementation of the KBE methodology. Among his main tasks there are: (i) extracting knowledge from people, (ii) translating existing knowledge in a computer-readable format, (iii) including the formalized knowledge in a computer program and (iv) validating the formalized knowledge and the obtained software application. If the KBE application is easy to maintain and update, after the knowledge-based system is constructed, it can be maintained by the domain expert. However, sometimes the domain expert has not the requested competences to properly maintain the knowledge-based systems and thus the support from the knowledge engineer is needed. The first and traditional KBE systems were based on programming languages that required some specific skills typical of the IT and programming field. In this first KBE approach the role of the knowledge engineer was limited to dealing with existing knowledge and supervising the development of the software application in close collaboration with the programmer. More recent developments of KBE tools have brought on the market new tools that support the development of KBE applications with already programmed integration, data formats and programming interfaces (e.g. the software used for this study – Rulestream[59]). These tools were born with the promise of eliminating the need of a programmer in the workflow of building a KBE application. However, as it will be described throughout this study, these software still requires a lot of programming skills to be effectively used. This concept is shown in Figure 12: the main actors involved in the development of a KBE application are the subject matter expert (i.e. the person that retains the knowledge about the product and the design process) and the knowledge engineer (i.e. the person in charge of extracting this knowledge and making it available through a knowledge based application). The programmer is the person that helps the knowledge engineer in building the application. As anticipated, his role is crucial in the development process.

Application - Specification Definition

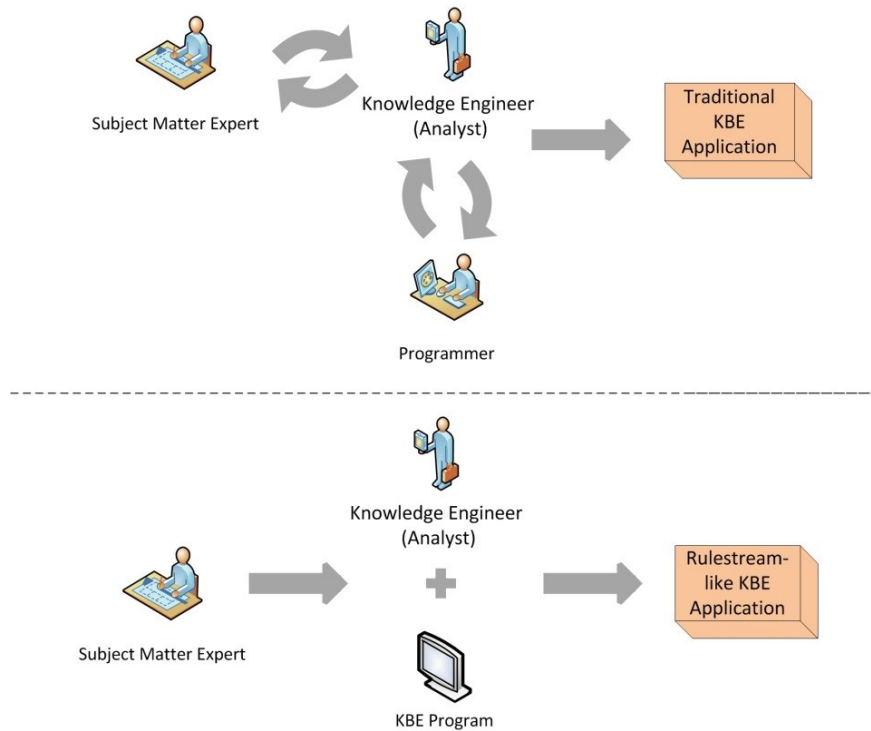

Figure 12: The role of the knowledge engineer in the traditional and new generation KBE approaches.

5.1.2. Case Study – Cylinder Head Assembly

Hence, the current case study is focused on the assembly of valves into an engine cylinder head. An automobile valve train is the high-speed cam-follower mechanism responsible for synchronizing the intake and exhaust of gases in cylinders of an internal combustion engine. The valves require small coil springs, appropriately named valve springs, to keep them closed when not actuated by the camshaft. They are attached to the valve stem ends, seating within spring retainers. Traditional automotive engines may have 2 or 4 valves per cylinder. The components that have to be assembled are shown in Figure 13. The intake and exhaust valves have different dimensions. Figure 13 shows also a side view of an engine cylinder head and the positioning of the valves with respect to the camshafts and the piston.

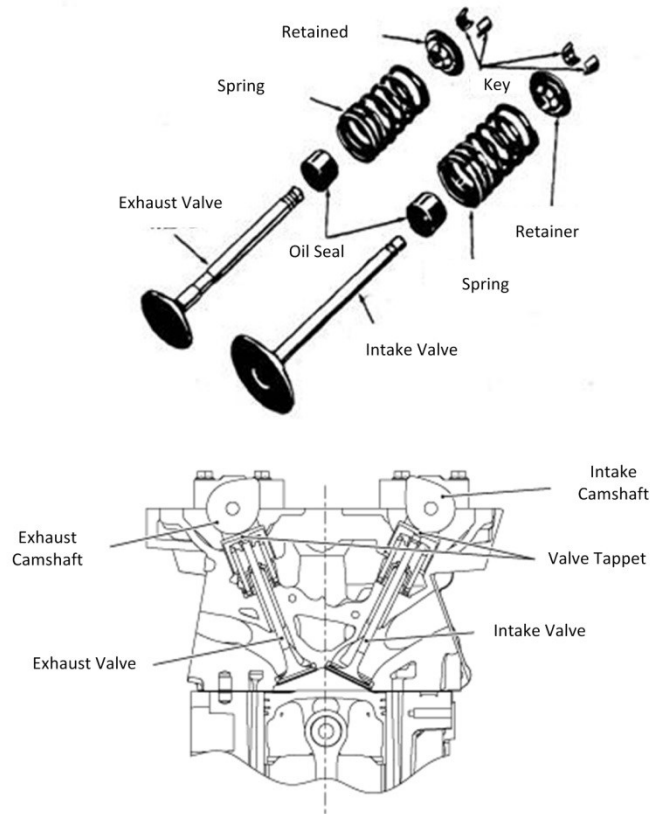

Figure 13: Valve Train assembly

The insertion of valves into the cylinder head is performed by a defined sequence of operations described by Ascheri et al. [4] and listed in Table 3. Table 3 reports the assembly tasks and the distribution on different workstations. The columns on the right show the cycle time threshold values (in seconds) that guide the choice of the workstation type from a manual station (M) to a semi-automatic (S) station to a fully automated one (A). The pieces of information contained in Table 3 are some of the outputs of the KA and formalization phases described in the following sub-chapters.

Application - Specification Definition

Table 3: Sequence of the operations needed to perform powertrain valve assembly on a cylinder head.

OP #	Task	Description	<25s	25-40s	>40s
10	Identify and Load cylinder head to pallet	The cylinder head comes from the machining line. It is identified with a barcode reader to guarantee the traceability along the process and loaded onto the pallet.	A	S/M	M
20	Lubricate valve guide bores or valves	The valves are oil lubricated to facilitate insertion into the cylinder head	A	M	M
30	Install intake and exhaust valves	Both intake (they let the air in) and exhaust valves (they let the air out) are inserted into the cylinder head. The two valves types have different dimensions and should not be confused	A	A	M
40	Valve run-in (optional)	The valves are moved inside their guide (usually rotated) to eliminate possible blurr in the cylinder head.	A	A	A
50	Valve blow-by leak test	Air is inflated into the cylinder head to verify possible clearances in the insertion of the valves.	A	A	A
60	Rollver 180°	The cylinder head is rotated by 180° to position the valve train side up.	A	A/M	M
70	Assemble valve stem seal washer	Insertion of the valve steam seals	A	A/M /S	M
80	Assemble valve springs, valve spring retainer	Insertion of valve springs and valve spring retainers	A	A/M /S	M
90	Key-up	Operation of joinings retainers and valve keys and installing them in the valve guide by pressing together springs and retainers. Both for intake and exhaust valves	A	A	A
100	Valve key check	Air is inflated into the cylinder head to verify the correct assembly of the valve keys.	A	A	A
110	Shakeout	The cylinder head is rotated along the horizontal axis to verify the presence of components not properly assembled.	A	A	A
120	Cylinder head label	The cylinder head is marked at the end of the cycle.	A	M	M
130	Unload cylinder head assembly	The cylinder head is unloaded from the pallet	A	S/M	M

5.2. Knowledge Acquisition

There are many definitions in the literature about knowledge. Nevertheless, most of them agree in considering knowledge as a highly structured form of information and what is needed to think like an expert. Milton [60] summarizes the concept of knowledge in an intuitive yet comprehensive definition:

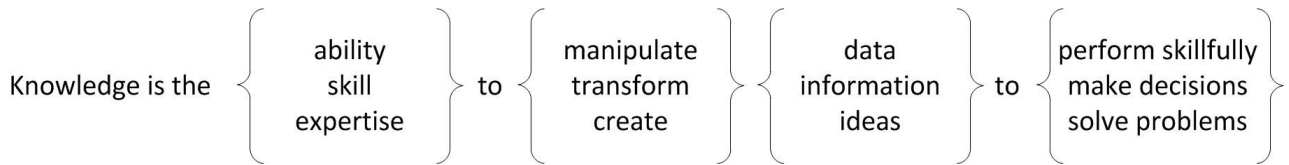

Figure 14: Multi-fold definition of Knowledge from Milton [60]

Knowledge used and generated during the engineering phase of a production system can be of different types: explicit, implicit and tacit. This differentiation proposed by Zheng [61] is slightly different with respect to the traditional categorization between explicit and implicit knowledge [62]. We found that knowledge within a company has features that can be better clustered using three different categories. Table 4 summarizes, for each type of knowledge, the definition, an example for the production system design, and the KA techniques and tools used.

Table 4: Types of knowledge and relative acquisition techniques and examples.

	Explicit	Implicit	Tacit
Definition	Already formalized technical knowledge usually stored in documents and databases	Knowledge not written down, largely procedural and not based on the individual context	Knowledge important in design activities and difficult to be codified, made up by experience and personal context
Example	Bill of process for engine assembly	Selection of station automation level based on cycle time	Knowledge of specific customer preferences or requirements
KA techniques	Knowledge retrieval	Concept/process map	Observation, Matching Input/Output
KA tools	Spreadsheets, databases	UML, IDEF, mind maps	Rules editor

Knowledge is usually divided into conceptual and procedural knowledge. Conceptual knowledge is about the ways in which things are related to one another and about their properties. On the contrary procedural knowledge is about tasks, processes and activities and about how are they performed and in which order.

Knowledge acquisition is considered to be one of the most difficult tasks done by the knowledge engineer while building a knowledge-based system [63]. According to Milton [60] , before starting a

knowledge acquisition it is important to define end-product and end-user. Typically knowledge acquisition are aimed at the creation of a knowledge base (i.e. *k-base*). In this specific case our k-base is part of the development of an intelligent computer system. Hence, the k-base is re-written as a document called *knowledge document* that will be passed onto the software development phase of the KBE system.

For a knowledge acquisition activity to be successful, the project must be run in an efficient way making the most use of the available resources; thus the project should not unduly disrupt the normal running of the organization and involve too much time from experts. Milton suggests the application of a 47-step procedure for KA projects. Despite for this specific case study only some of the techniques were involved and a simplified procedure was adopted. KA in particular can be subdivided into capture and modelling.

The KA for the specific case study was conducted over a period of one month. Of all the engineers and designers that work for the proposal of powertrain assembly systems in Comau, five people were involved during this phase. Two designers of this group have around 20 years of experience in the powertrain assembly field, other two have more than 10 years of experience while the youngest engineer has been working in the proposal group for 2 years.

The three main sources during this KA phase have been:

- Proposal engineers and designers. The interaction with designers and engineers in Comau were constant over the period of the research, not only during the KA phase. This was made possible by the industrial nature of the research.
- Databases. A lot of knowledge is already stored in the company databases. However, all this knowledge is stored in different locations and sometimes only available in non-electronic format. The core of this database knowledge is the past experience of the company. In fact all the data and info of past projects are stored and available for consultation.
- Standard Products. The knowledge about standard products is critical in this phase as it is used for instance in the definition of the conceptual architecture of the line and its functional modules. Part of this knowledge is better represented in Section 2.3.2.

Given the nature of the identified problem a restricted number of K-base acquisition and modelling techniques were chosen. The different techniques chosen try to cover all the aspects of the knowledge that has to be collected. The toolkit for the KA included a series of methodologies such as semi-structured interview techniques and modelling techniques (i.e. laddering, concept mapping and process mapping) to elicit and validate implicit knowledge. However we did not use existing software packages (e.g. PCPACK [64] or Protégé [42]) not to add unnecessary complexity. The only tools used for the creation of the knowledge document has been an excel spreadsheet, widely accepted and used among the same designer and engineers.

Figure 15 shows the main techniques used based on a two dimensional graph according to Milton [60].

Interview techniques. Interview Techniques involve questioning the experts and are considered good for eliciting basic knowledge. There are usually 3 variants: unstructured interview, semi-

structured interview and structured interview. For this specific case, the semi-structured interview was chosen as the right technique as it allows some degrees of freedom to the interviewees without being too closed. It uses a pre-defined set of questions that are sent to the expert beforehand, and supplementary questions that are asked at the interview. Designer and engineers were interviewed both individually and in groups.

The questionnaire contained 3 main questions that reflect 3 aspects about which knowledge has to be collected: assembly line, design steps and configuration rules.

- i. What are the main elements that compose a powertrain assembly line?*
- ii. What are the main steps for the design process of powertrain assembly lines?*
- iii. What are the main configuration rule that you apply during the various design steps?*

The results of this questions have been elaborated and further discussed during face to face meetings to visualize the expressed knowledge (e.g. mind maps or spreadsheet) and validate it.

Observation Techniques. One of the acquisition techniques to understand how designers work is observation. To observe a phenomenon in its natural setting and making notes can be a time-consuming task [65] but useful for capturing hidden interactions, decision making procedures and closely see repetitive design tasks. A few meetings and spreadsheet can catch nothing but a part of the design process rationale. Observation techniques allow to investigate the process without interfering too much with the work of designers and engineers. Nevertheless observation may fail to catch some of insight into why decisions are made if it does not interrupt the work of the designer with an active participation. In this specific case, the opportunity to observe the participants in their work environment and actively participate in the process was facilitated thanks to the development of the entire research project within the same industrial environment.

Process and Concept Mapping. Process and Concept Mapping are useful for informally visualizing the elicited knowledge and validating it. There are commercially available useful mind mapping tools that can help in this task. After the acquisition phase, process mapping is usually formalized in the next step of the methodology by using diagramming techniques such as IDEF0. At the same time concept mapping is formalized using UML diagrams. These graphs are presented in section 5.3.

Document Analysis. As already mentioned, the KA included the retrieval of existing documents containing explicit knowledge. In this specific case it was especially useful the analysis of the documentation relative to past technical proposals and RFQs. The analysis of real past examples of requests from customers and corresponding technical offers trying to match inputs from the customer with outputs of the technical offer and mapping the rules that lead to these decisions. Moreover this analysis was useful to map the list of technical requirements that are recurring the past request for quotation.

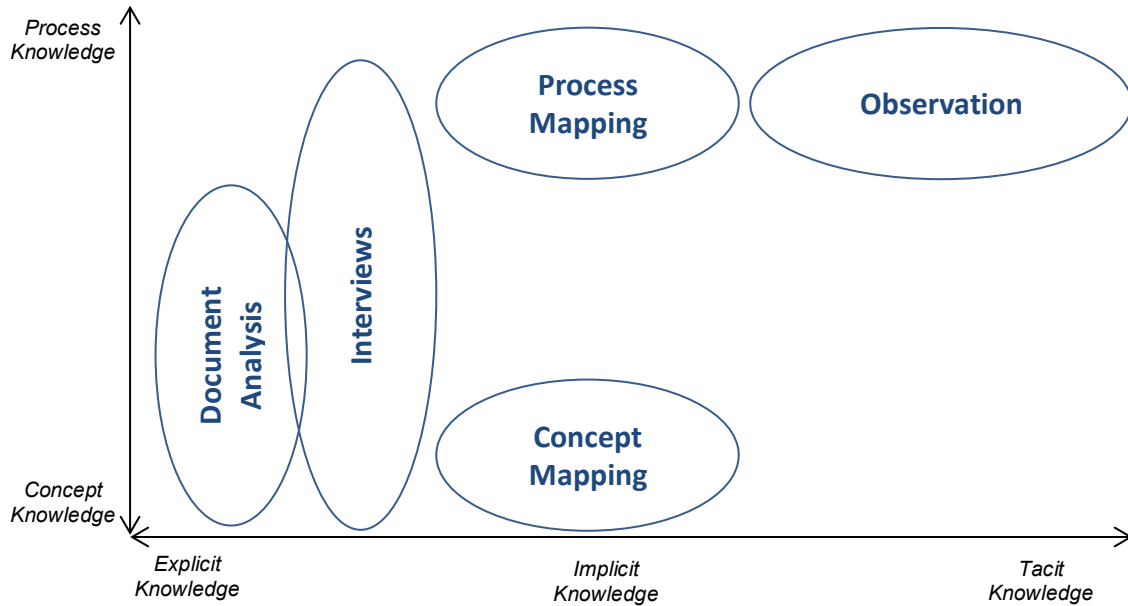

Figure 15: Main KA techniques used for the specific case study.

For this specific KBE application, the retrieval of existing knowledge within the company covers two aspects: knowledge about the assembly line and the relative design process.

- **Assembly Line (Product):** As anticipated, there are three basic types of assembly systems: manual assembly, carried out by human assemblers, usually with the aid of simple power tools; hybrid assembly systems that combine human assemblers and automated mechanisms and robots (semi-automatic); fully automated assembly systems. A key feature of assembly systems is a flexible modular conveyor system that can operate asynchronously and be reconfigured to accommodate a large variety of component choices according to the product being assembled [66]. One of the difference with traditional KBE system is that the presented application focuses on the configuration of a production systems. Traditional KBE methodology recommends to collect existing knowledge about the product and the design process. This concept, applied to our application implies considering the assembly line as product. From a high level of abstraction we considered the functional components of an assembly line as the modular components of a product.
- **Design Process:** for designing an assembly line it is crucial to know in detail the sequence of the assembly processes performed on the product and the characteristics of each operation. The objective of the acquisition of this knowledge is to understand what are the steps that the designers follow during the design process of an assembly line. It is important to define not only which are the steps in the configuration process but also which decisions are taken at each step. The steps of the KBE application will try to replicate the design workflow described by the designers.

Figure 16 shows an example of acquired knowledge in an unstructured format (i.e. Microsoft Excel spreadsheet) deriving from interviews and observations.

Application - Knowledge Acquisition

	A	B	C	D	E	F	G	H	I	J	K	L	M	N																																																																																										
1			POWERTRAIN ASSEMBLY LINE CONFIGURATION																																																																																																					
2			1	CLIENTE	<input type="text" value="PPT"/>	Plant Location	<input type="text" value="LATAM"/>																																																																																																	
3	2 PRODOTTO		<input type="text"/>	<input type="text" value="Multi-Step"/>	N° VARIANTI	<input type="text" value="2"/>	WEIGHT	<input type="text"/>																																																																																																
4			N° VALVES (var1)	<input type="text" value="8"/>	WEIGHT	<input type="text"/>																																																																																																		
5			N° VALVES (var2)	<input type="text" value="16"/>	WEIGHT	<input type="text"/>																																																																																																		
6																																																																																																								
7	3 CYCLE TIME		Cycle Time		<input type="text" value="40"/>																																																																																																			
8			4 PROCESS		<table border="1"> <thead> <tr> <th></th> <th></th> <th></th> <th></th> <th></th> <th><25s</th> <th>25-40s</th> <th>>40s</th> <th>Resulting</th> <th>Station</th> </tr> </thead> <tbody> <tr> <td>10</td> <td>Load cylinder head to pallet</td> <td>Staz 10</td> <td></td> <td></td> <td>A</td> <td>M</td> <td>M</td> <td>AUTO</td> <td>SMART MAN</td> </tr> <tr> <td>20</td> <td>head</td> <td></td> <td></td> <td></td> <td>A</td> <td>M</td> <td>M</td> <td>AUTO</td> <td></td> </tr> <tr> <td>30</td> <td>Lubricate valve guide bores or install intake and exhaust valves</td> <td>Staz 20</td> <td></td> <td></td> <td>A</td> <td>A</td> <td>M</td> <td>AUTO</td> <td>SMART ROB 1800</td> </tr> <tr> <td>40</td> <td>Valve run-in</td> <td>Staz 30</td> <td></td> <td></td> <td>A</td> <td>A</td> <td>A</td> <td>AUTO</td> <td>SMART ROB 1800</td> </tr> <tr> <td>50</td> <td>Valve blow-by leak test</td> <td>Staz 40</td> <td></td> <td></td> <td>A</td> <td>A</td> <td>A</td> <td>AUTO</td> <td>SMART ROB 1800</td> </tr> <tr> <td>60</td> <td>Turnover 180°</td> <td>Staz 50</td> <td></td> <td></td> <td>A</td> <td>A</td> <td>A</td> <td>AUTO</td> <td>SMART ROB 1800</td> </tr> <tr> <td>70</td> <td>Assemble valve stem seal washer</td> <td>Staz 60</td> <td>Depends on valve</td> <td></td> <td>A</td> <td>A/M</td> <td>M</td> <td>MANUAL</td> <td>SMART MAN</td> </tr> <tr> <td>80</td> <td>Press valve stem</td> <td>Staz 70</td> <td>Depends on valve</td> <td></td> <td>A</td> <td>A/M</td> <td>M</td> <td>MANUAL</td> <td>SMART MAN</td> </tr> </tbody> </table>																	<25s	25-40s	>40s	Resulting	Station	10	Load cylinder head to pallet	Staz 10			A	M	M	AUTO	SMART MAN	20	head				A	M	M	AUTO		30	Lubricate valve guide bores or install intake and exhaust valves	Staz 20			A	A	M	AUTO	SMART ROB 1800	40	Valve run-in	Staz 30			A	A	A	AUTO	SMART ROB 1800	50	Valve blow-by leak test	Staz 40			A	A	A	AUTO	SMART ROB 1800	60	Turnover 180°	Staz 50			A	A	A	AUTO	SMART ROB 1800	70	Assemble valve stem seal washer	Staz 60	Depends on valve		A	A/M	M	MANUAL	SMART MAN	80	Press valve stem	Staz 70	Depends on valve		A	A/M	M
							<25s	25-40s	>40s	Resulting	Station																																																																																													
10	Load cylinder head to pallet	Staz 10					A	M	M	AUTO	SMART MAN																																																																																													
20	head						A	M	M	AUTO																																																																																														
30	Lubricate valve guide bores or install intake and exhaust valves	Staz 20					A	A	M	AUTO	SMART ROB 1800																																																																																													
40	Valve run-in	Staz 30					A	A	A	AUTO	SMART ROB 1800																																																																																													
50	Valve blow-by leak test	Staz 40					A	A	A	AUTO	SMART ROB 1800																																																																																													
60	Turnover 180°	Staz 50					A	A	A	AUTO	SMART ROB 1800																																																																																													
70	Assemble valve stem seal washer	Staz 60			Depends on valve		A	A/M	M	MANUAL	SMART MAN																																																																																													
80	Press valve stem	Staz 70			Depends on valve		A	A/M	M	MANUAL	SMART MAN																																																																																													

Figure 16: Example of an Excel spreadsheet collecting non-formalized knowledge.

5.3. Knowledge Formalization

After the acquisition phase, the collected knowledge is formalized using tools for knowledge formalization including graphical representations of product architecture and process model. Knowledge representation is therefore very important to be coherent in all the relevant domains of the design. The development of the KBE application, including application programming and integration, has been done in close collaboration with Politecnico di Milano. Most of the graphs and algorithm presented in the following can be found also in [67].

The formalization of the collected knowledge is developed on three main levels: Powertrain Assembly Line, design process and configuration rules. The configuration rules were collected also during the KA phase but they represent a specific component of the formalization given their importance in the KBE application.

5.3.1. Powertrain Assembly Line

Powertrain Assembly Line: this knowledge formalization is dedicated to create the object-oriented KBE application and is supported by graphical representations (i.e. UML). UML purpose is, in fact, to design software programs, but its visual style is especially suitable for supporting knowledge formalization [68].

The “heart” of a product configuration system is represented by the product model. The product model is a logic structure that formally represents the type of product offered in terms of characteristics (commercial and technical) and constraints between characteristics. At the same time the product model is a set of rules to map commercial and technical characteristics into product documents (bills of materials, but also routings, diagrams, etc.). In other words, the product model sets the rules for dynamically building the product variant documentation starting from the specific needs of the customer. The decision made by the company management to use the configuration system made it possible to transform a set of competencies tied to specific individuals into a knowledge structure embodied into the company information system. In other words the product configurator enabled the transformation of individual competencies into organisational competencies.[69]

The basic components of the assembly line are: workstations, conveyors and pallets. The execution of the operations is held by three different kinds of station: automatic, semi-automatic and manual. The conveyors are characterized by two main types: roller and chain. The main parameters are width and speed depending on the size and weight of the product being assembled (i.e. cylinder head in this case). The conveyors length inside the station depends on the station type: for automatic stations the conveyors is 4000 mm long, while for manual and semi-automatic is 3000 mm long. The pallet type depends directly on the conveyor width. Figure 17 represents the concept tree of the powertrain assembly line in the form of a UML Class Diagram. The top class of the UML represents the *plant* class. More than one line can belong to the same plant. Lines are composed by multiple stations and pallets and one conveyor systems which comprises many conveyor modules. The volume mix class manages all the tasks and the balancing algorithms. The single workstations are composed by equipment and functional modules.

Application - Knowledge Formalization

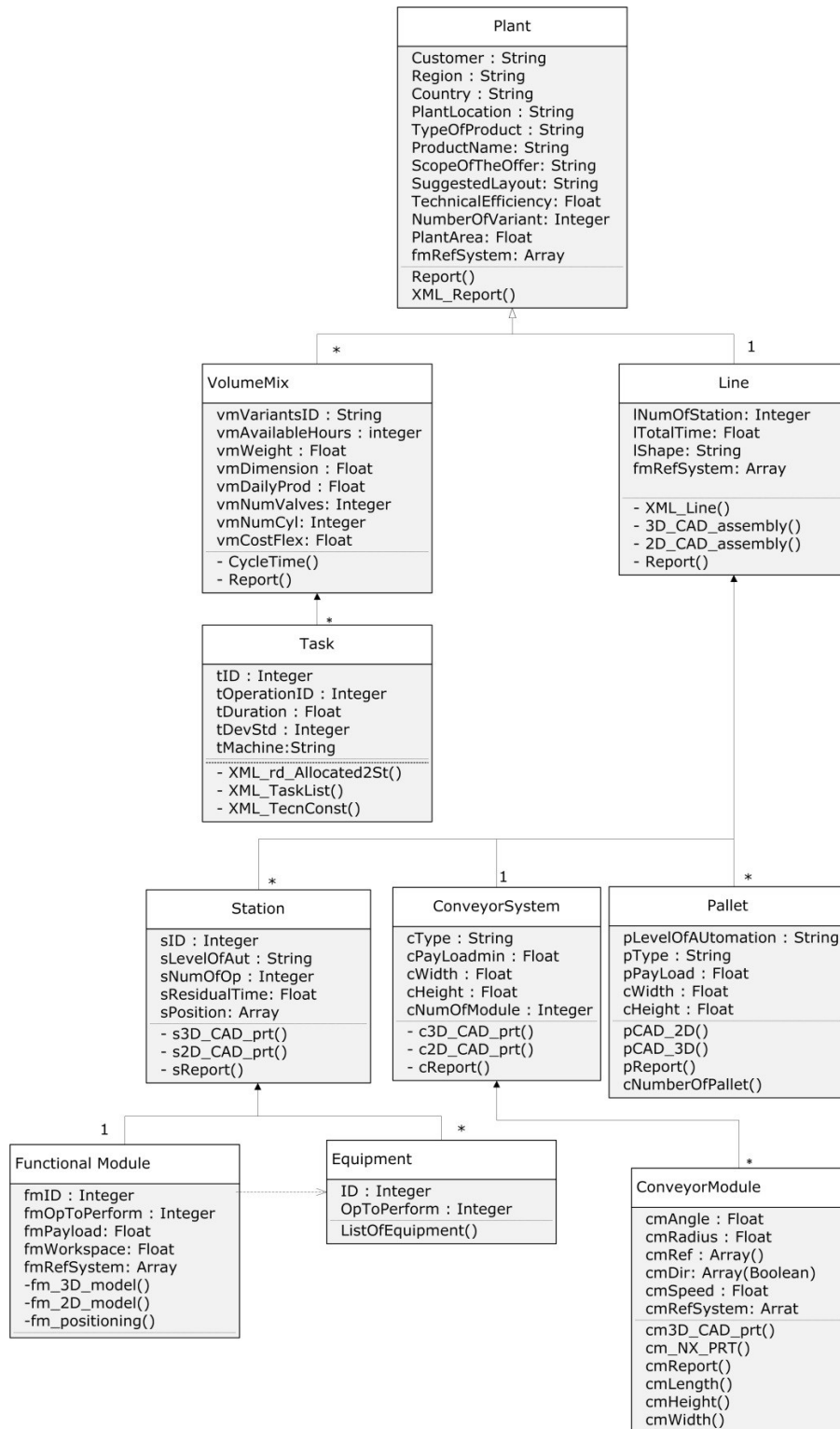

Figure 17: UML scheme of the powertrain assembly line.

5.3.2. Design Process

The design process should reflect all the steps that the designers follow when configuring a system. Design processes are formalized using the IDEF0 method. IDEF0 is a method designed to model the decisions, actions, and activities of an organization or system. The *box and arrow* graphics of an

IDEFO diagram show the function as a box and the interfaces to or from the function as arrows entering or leaving the box. To express functions, boxes operate simultaneously with other boxes, with the interface arrows constraining when and how operations are triggered and controlled [70]. The basic syntax for an IDEFO model is shown in Figure 18.

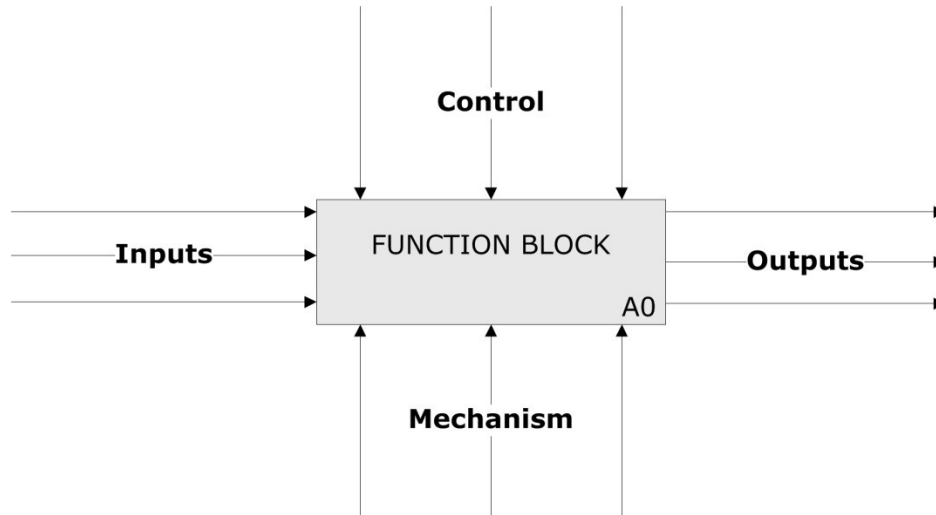

Figure 18: Basic Function Block of the IDEFO notation

At high level, the KBE process mapped using an IDEFO diagram is shown in Figure 19. The configuration process is divided into three main steps: product analysis, logical design and output generator. This process follows the steps that the designers indicated: first it is important to take into account the customer requirements and analyze them in detail. Then, the designer first thinks of the logical layout of the line, assigning operations and equipment to the workstations. Finally once the system has been configured the designer defines the physical layout of the line using CAD tools.

Each of the steps of the configuration has a sub-processes made for different sub-steps and specific inputs and outputs. This design process only takes into account the mechanical configuration of a powertrain assembly system. In parallel with this process also the preliminary controls and automation architecture is defined as well as the costs of the equipment.

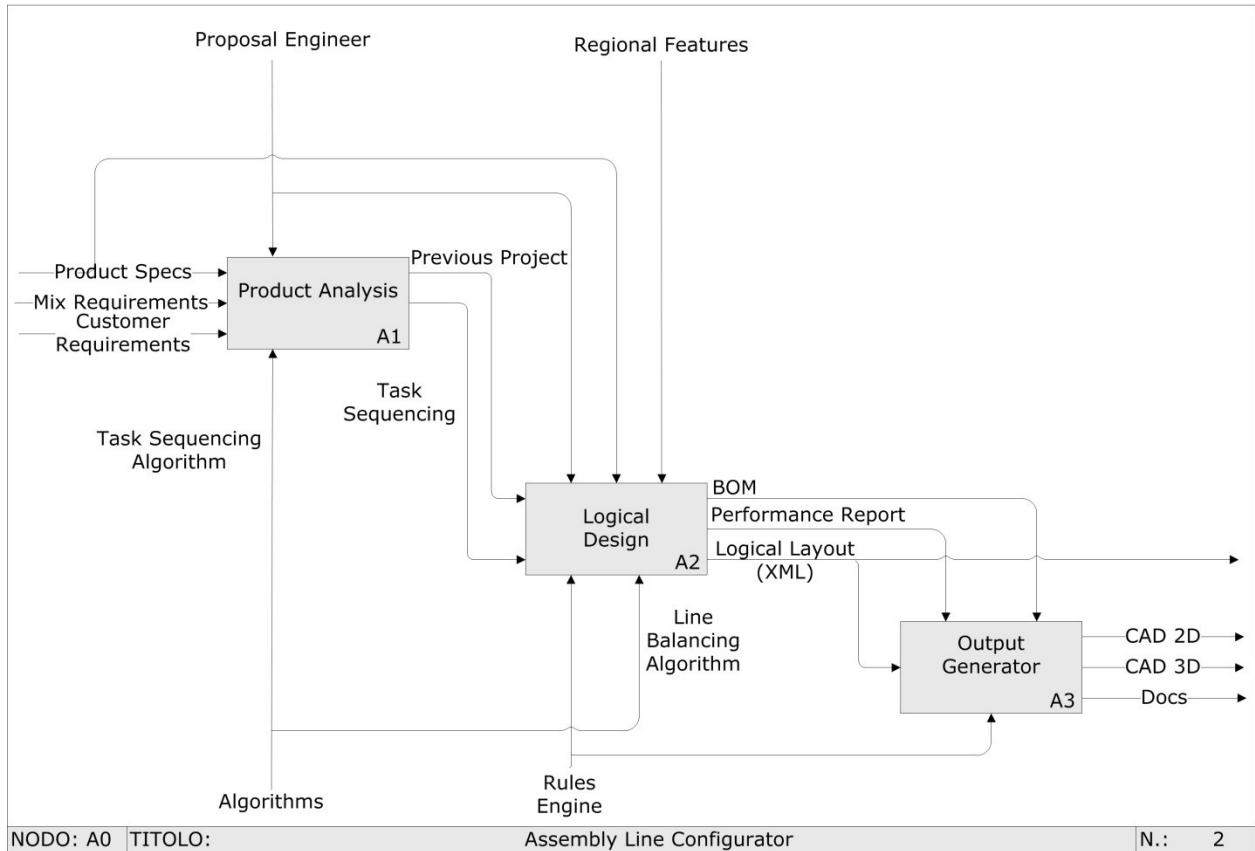

Figure 19: IDEF0 representation of the design process.

Product Analysis

Figure 20 details the product analysis block. The first procedure, named database analysis, takes in input the customer specifications about the product. The output of this procedure is the identification of previous projects for the same customer. At the same time the choice of the product which is being assemble determines the creation of the operation list. are the previous projects that regards the customer and the operations list to assemble that particular product. Engines and transmissions are quite consolidated products and the operation lists and sequence are part of the company knowledge assets and stored in the company databases. Nevertheless, the lists of operations contain references to the elementary tasks with all the IDs of the tasks, the nominal duration, the used equipment and the standard deviation. However, for taking into account variations on the assembled products, a parametrization of the tasks have been defined (e.g. the time of the task *valve insertion* changes based on the number of cylinders and valves of the engine). Finally, the last block is the precedence graph, a diagram that graphically represents the different possible sequences of tasks that have to be accomplished.

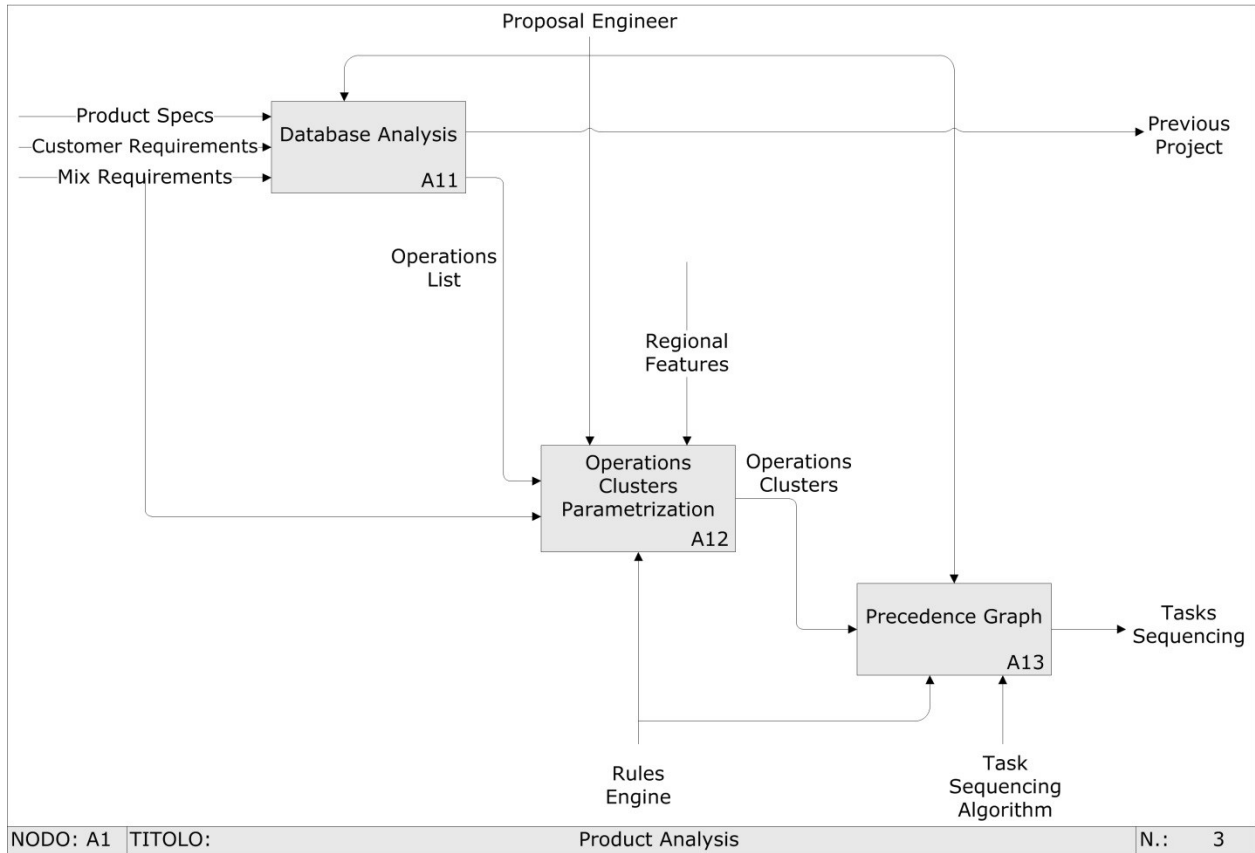

Figure 20: Detail of the processes inside the Product Analysis block

Logical Design

The logical design phase includes the choice of the equipment based on the tasks to be performed in the defined cycle time. The choice of the equipment is highly influenced by the regional features (i.e. where the line has to be installed). One critical part of the logical design is the assembly line balancing algorithm. Section 5.3.3 dealing with configuration rules, explains more in detail the chosen line balancing algorithm. The same applies to the conveyor design. Figure 21 shows the detailed IDEF0 for the *logical design* step.

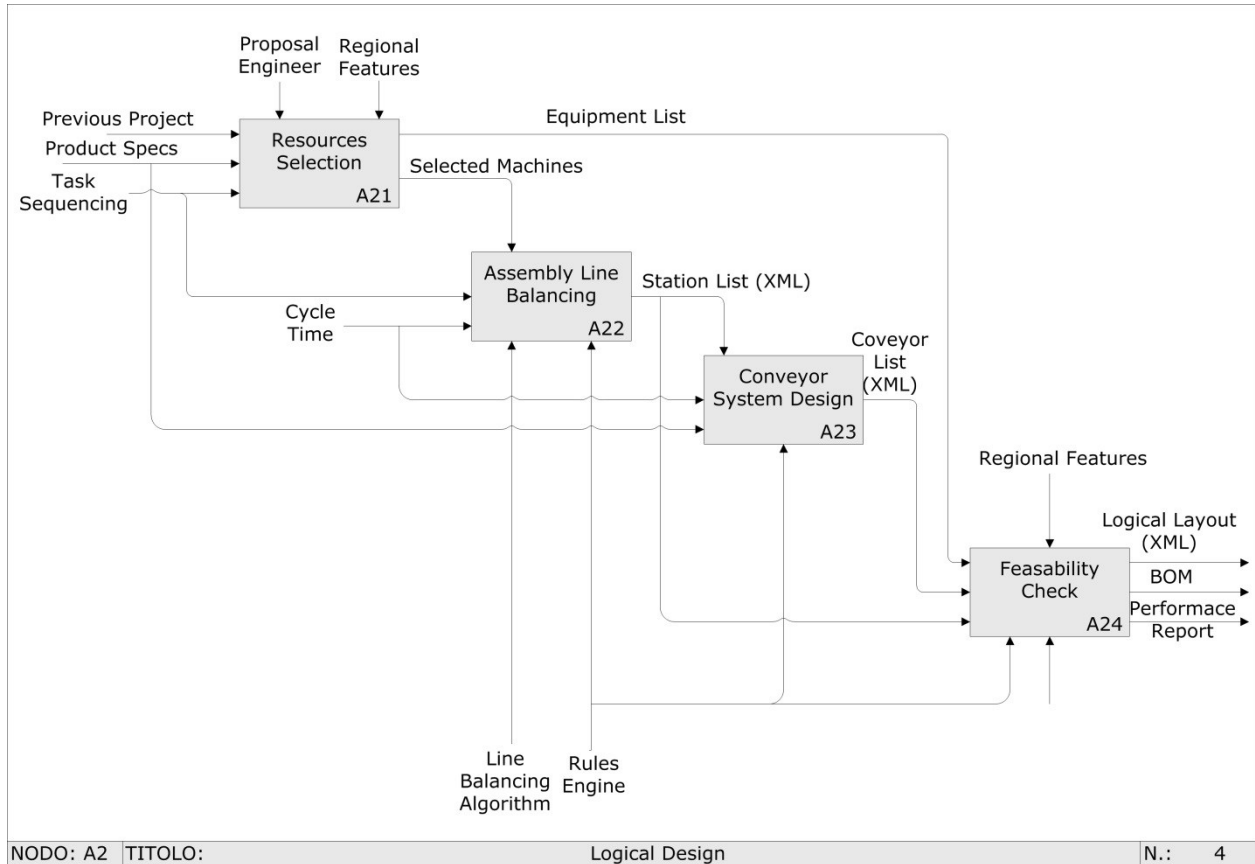

Figure 21: Detail of the processes inside the Logical Design block

Output Generator

The last step of the design procedure is the *output generator*. This specific step can be divided into three blocks as shown in Figure 22. The *3D generator* block takes in input the information about the logical layout contained in the XML file. Through some queries to the 3D models database, the parts needed to build the 3D model of the line are selected. The XML line contains also the information about the position of each component of the line. Hence, the application exploits this information to put each module in its correct layout position. The *2D generator* step takes in input the coordinates of the parts from the *3D generator* block contained in an XML file. Starting from these data, the 2D AutoCAD models are retrieved through specific queries. The output of this activity is a 2D CAD layout corresponding to the 3D layout previously generated. Finally, the last step of the procedure is the generation of the technical report of the line, a document similar to the so called Scope of Supply (SoS), the technical documentation of the line with general information and detailed description of all the workstations. This document is the basis for the quotation of the supplied equipment which has to be performed by the estimating department shortly after or in parallel with the technical proposal. The *report generation* procedure takes in input the Bill of Material (BOM), the technical drawings of the line, the 3D CAD models, the equipment list and the performance report. The output is a document that summarizes all the assembly line documentation.

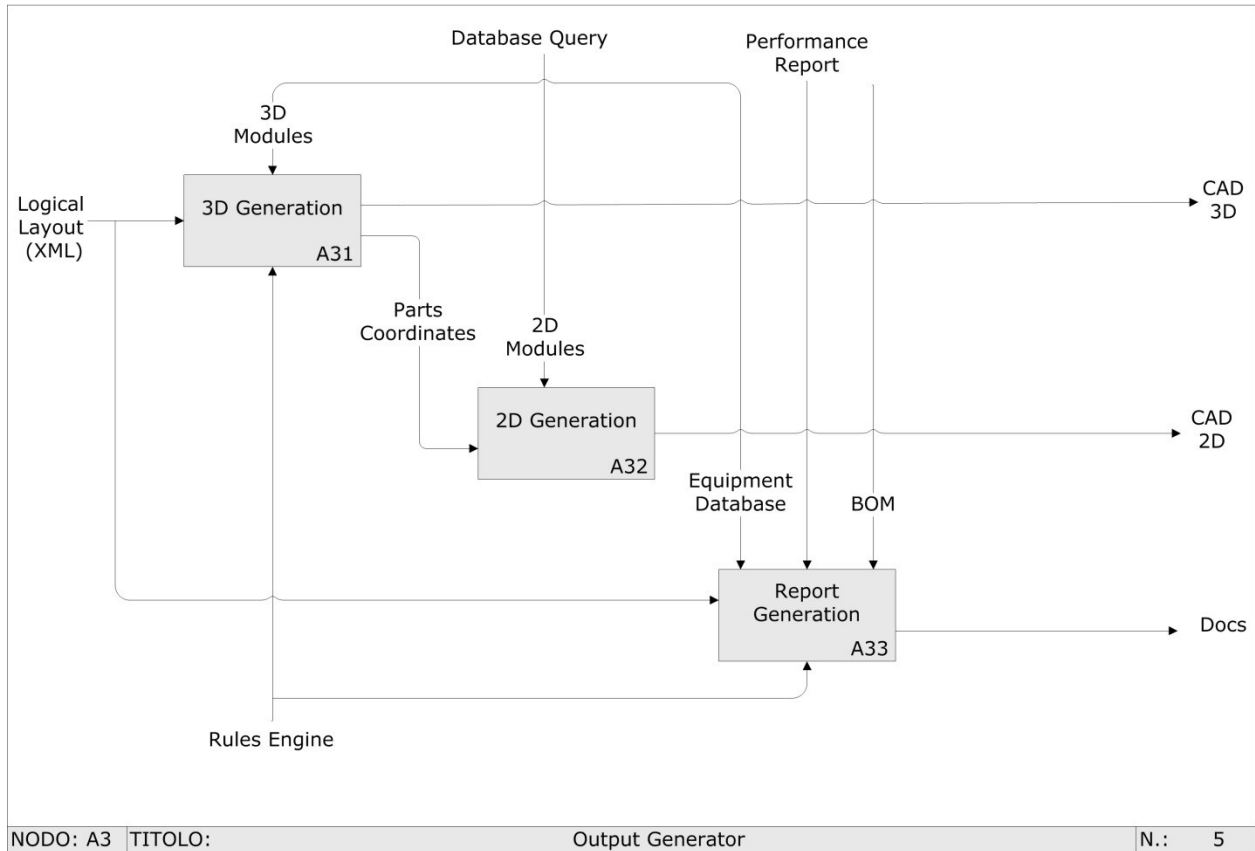

Figure 22: Detail of the processes inside the Output Generator block

5.3.3. Rules

In KBE parlance, all the possible expressions used to define attributes, specify the number and type of objects, communicate with external tools, and so on, are addressed with the generic term of rules (or engineering rules). For this reason, KBE is often addressed as a technology to perform rule based design [33]. The main typologies of KBE rules are:

- **Logic rules (or conditional expressions):** such as the basic IF-THEN rule;
- **Math rules:** any kind of mathematical rule is included in this group;
- **Geometry manipulation rules:** geometric rules such as parametric rules belong to this category and are typical features of a KBE system;
- **Configuration selection rules (or topology rules):** these rules are actually a combination of mathematical and logic rules. They are used to change and control dynamically the number and type of objects in an object tree. Hence they can affect the topology of any product and process KBE model.
- **Communication rules:** in this group all the specific rules that allow a KBE application to communicate and/or interact with other software applications and data repositories are included. Rules exist that allow accessing databases or retrieve data and information to be processed within the KBE application. Other rules exist to create files containing data and information generated by the KBE application. For example, it is possible for a KBE application to generate as output standard geometry exchange data files like STL, IGES and STEP; or XML files or any sort of free format ASCII files for more textual data. Rules also exist

to start at runtime external applications, wait for results, collect them and return to the main thread.

One of the objectives of knowledge formalization is to translate design habits and knowledge, where possible, into engineering rules. The specific KBE application of this study is highly based on configuration rules and communication rules.. Hence, some of the acquired and formalized rules are summarized in Table 5.

Table 5: Examples of line configuration rules formalized and explained.

Rule	Explanation
<p>Automation Level:</p> <p><i>For Each Task in OperationTable</i></p> <p style="padding-left: 20px;"><i>If CycleTime < Task.LowTreshold</i></p> <p style="padding-left: 40px;"><i>AutomationLevel = OperationTable (Task, LowCT)</i></p> <p style="padding-left: 20px;"><i>Elseif Task.LowTreshold < CycleTime < Task.HighTreshold</i></p> <p style="padding-left: 40px;"><i>AutomationLevel = OperationTable (Task, MedCT)</i></p> <p style="padding-left: 20px;"><i>Else</i></p> <p style="padding-left: 40px;"><i>AutomationLevel = OperationTable (Task, HighCT)</i></p> <p style="padding-left: 20px;"><i>End If</i></p> <p><i>Next</i></p>	<p>A high cycle time generally corresponds to a reduction in the level of automation, except from particular tasks where high precision is required. The automation level is selected referring to the knowledge about operations and cycle time thresholds collected in Table 3. The typical IF-THEN statement is shown using Visual Basic (VB) pseudo-code.</p>
<p>Optimal number of pallets:</p> $N_{pallet} = \frac{L}{v * CT} + N_{Station} + C$	<p>The empirical formula used to calculate the number of pallets needed in an assembly line to guarantee the saturation of the line and the desired production level: N is the number of stations of the line, v is the conveyor speed, L is the conveyor developed Length, CT is the cycle time and C is a parameter that estimates the inefficiencies. The result of this formula is a good estimate of the number of pallets needed in the assembly line.</p>
<p>Length of the conveyor modules:</p> <p style="padding-left: 20px;"><i>If Station = Automatic or Semi-Auto</i></p> <p style="padding-left: 40px;"><i>ConveyorLenght = 4000mm</i></p> <p style="padding-left: 20px;"><i>Else</i></p> <p style="padding-left: 40px;"><i>ConveyorLenght = 3000mm</i></p>	<p>The design of the conveyor is based on a modular approach.</p> <p>The length of the conveyor module varies according to the different type of station (according to the modules, 4000mm for automatic stations and 3000mm for manual and semi-auto).</p>
<p>Assembly Line Balancing:</p>	<p>Typical algorithm for the configuration of</p>

	assembly line. The formulas are explained in detail in Section 5.3.4.
<p>Layout Shape:</p> <p><i>If conveyor shape = I shape AND Sum (conveyor modules) > available plant length</i></p> <p><i>Then</i></p> <p><i>Select different conveyor shape</i></p> <p><i>OR</i></p> <p><i>Turn left/right</i></p>	<p>The shape of the line layout is a variable that changes according to the customer that is requesting the assembly line. Main shapes of industrial layouts are basically three: straight line, U-shaped or O-shaped layout. Real world assembly line layouts can also have complex shapes that can be divided up to the elementary shapes identified.</p> <p>Some customer have preferences/requirements in terms of layout shape that are applied to all plants worldwide (e.g. FCA plants adopts the WCM World Class Manufacturing concept that imposes straight manufacturing lines). The preferences of the customers are known to Comau designers and even if they are not made explicit in the RFQ, customer and layout shape are matched by a configuration rule.</p> <p>Sometimes the customer may give existing spatial constraint for the area where the plant has to be installed. This constraint in its simplest form consists of a square area available for the installation of the line. If the sum of all the stations and conveyor modules in a straight configuration does not fit the available area, the straight conveyor is substituted by a right or left turn.</p>

All these rules are used to generate the first attempt configuration of the line. Nevertheless, the KBE application leaves space for a manual intervention of the user who can change some of the values set by the rules. The user can, in fact, *force* some values even if they contradict the ones automatically generated by the application.

5.3.4. Assembly Line Balancing Problem (ALBP)

One of the main *rules* guiding the configuration of the assembly line is the line balancing problem. It consists of distributing the total workload for manufacturing any unit of the product to be assembled among the work stations along the line [71]. Manufacturing a product on an assembly line requires partitioning the total amount of work into a set of elementary operations named tasks $V = (1, \dots, n)$. Performing a task j takes a task time t_j and requires certain equipment of machines and/or skills of workers. Due to technological and organizational conditions precedence constraints between the tasks have to be observed. The set S_k of tasks assigned to a station k ($=1, \dots, m$) constitutes its station load, the cumulated task time $t(S_k) = \sum_{j \in S_k} t_j$ is called station time. When a fixed common cycle time c is given (i.e. paced line), a line balance is feasible only if the station time of neither station exceeds c . In case of $t(S_k) < c$, the station k has an idle time of $c - t(S_k)$ time units in each cycle. In case of a paced assembly line, the station time of every station is limited to the cycle time c as a maximum value for each workpiece. Since tasks are indivisible work elements, c can be no smaller

than the largest task time $t_{max} = \max (t_j, j= 1, \dots, n)$. Due to the cycle time restriction, paced assembly lines have a fixed production rate (reciprocal of the cycle time).

The traditional design process of assembly lines is largely experienced based. The same applies to the allocation of operations in order to saturate the workstation operator by respecting the set cycle time. Part of the work has consisted in collecting these empirical rules and defining a suitable line balancing algorithm to be implemented in the KBE application for assigning operations to workstations.

Because of very different conditions in industrial manufacturing, assembly line systems and corresponding ALBPs in literature are multifaceted. The first known formulation regarding this topic has been made by Salvendy in 1955 [72]. Nevertheless, across the years assembly lines have increased in complexity and the theories on line balancing have evolved accordingly. The different algorithms that can be found in the literature take into account different variables that change the features of an assembly line such as production mix (i.e. single model, mixed model or batch line); consideration of work transport system is also a concern such as floor layout [71]. However most of these techniques refer to a specific balancing problem. Given the conditions of Comau assembly lines with fixed processes, designed for high volumes and the large scope of the configurator, this research work focuses on the basic combinatorial problem known in the literature as Simple Assembly Line Balancing Problem (SALBP), where “simple” refers to the single product model. Indeed, for the scope of our KBE application the implementation of a basic algorithm is the choice that guarantees the highest possible generalization. The line balancing is not the main focus of this thesis but it has the aim of helping the designer in a repetitive task without changing the overall structure of the application.

This algorithm withstands a series of assumptions:

- Mass-production of one homogeneous product; given production process; paced line with fixed cycle time c ;
- Deterministic (and integral) operation times t_j ;
- In case of incompleteness of an operation, the assembly keeps on flowing on the assembly line and all available following operations are carried out;
- All incomplete or not carried out operations are completed off-line;
- Serial line layout with m one-sided stations;
- Maximize the line efficiency $E = t_{sum}/(m \times c)$ with total task time $t_{sum} = \sum_{j=1}^n t_j$.

The line balancing algorithms present in the literature are usually classified based on the objective function that the solution method attempts to reach. In literature [6], the most widely used goal functions for SALBPs are:

- SALBP-1: Minimize the number of workstations for a given cycle time;
- SALBP-2: Minimize the cycle time for a given number of workstations;
- SALBP-E: Determines whether or not a feasible assembly configuration exists for a given combination of cycle time and number of workstations.

- SALBP-F: attempts to maximize the line efficiency by minimizing the number of workstations and cycle time simultaneously.

The solution methods are often divided into two categories: exact or approximate. The required computational time for obtaining an optimal solution with an exact method increases exponentially with the size of the problem considered: approximate methods are needed in order to cope with large scale cases [73]. For this reason the approximate solution method fits better to the aims of this application. Another important issue is how the task processing time is considered: it can be treated as deterministic or stochastic. The presented use case involves both automatic and manual workstation. For this reason is necessary to consider the task operation time as a stochastic variable. The heuristic algorithm used in this work is commonly referred to in the literature also as the *maximum incompleteness probability allowed*.

The algorithm is based on the calculation of the probability that an operation, if allocated to a workstation, is not completed. If the incompleteness probability is lower than a given threshold (P^*) the operation is allocated to the present workstation. Otherwise, a new workstation is opened and equipped and the operation allocated to it.

At each step, given the operations already allocated to a workstation, the residual available time (RT) after having allocated the k -th operation is calculated as follows:

$$RT_k = CT - \sum_{i \in S} t_i;$$

where t_i is the average duration of i -th operation, S is the set of operations allocated to the station (including the k -th operation) and CT is the cycle time. The incompleteness probability represents the probability that $RT < 0$ and each operation has to be:

$$P_k < P^*;$$

where P_k is the incompleteness probability of the k -th operation while P^* is the maximum incompleteness probability allowed. The value of P^* is fixed by the user: a high value of the incompleteness probability may involve a high number of stations (i.e. more expensive lines). The Z-score of residual time (normally distributed) is given by:

$$Z_k = \frac{RT_k}{\sqrt{\sum_{i \in S} s_i^2}};$$

The incompleteness probability represents the probability that an operator conducts all the operations allocated to a workstation in a period of time larger than the cycle time:

$$P\left(\sum_{i \in S} T_i > CT\right) = 1 - P\left(\sum_{i \in S} T_i \leq CT\right) = 1 - P\left(\frac{\sum_{i \in S} T_i - \sum_{i \in S} T_i}{\sqrt{\sum_{i \in S} s_i^2}} \leq \frac{CT - \sum_{i \in S} T_i}{\sqrt{\sum_{i \in S} s_i^2}}\right);$$

If variables T_i are independent among them:

$$\sum_{i \in S} T_i \sim N \left(\sum_{i \in S} t_i, \left(\sum_{i \in S} s_i^2 \right)^{\frac{1}{2}} \right);$$

Thus:

$$\frac{\sum_{i \in S} T_i - \sum_{i \in S} t_i}{\sqrt{\sum_{i \in S} s_i^2}} \sim N(0,1);$$

Therefore:

$$P_K = P \left(\sum_{i \in S} T_i > CT \right) = 1 - \varphi \left(\frac{CT - \sum_{i \in S} t_i}{\sqrt{\sum_{i \in S} s_i^2}} \right) = 1 - \varphi \left(\frac{RT_k}{\sqrt{\sum_{i \in S} s_i^2}} \right) = 1 - \varphi(Z_k);$$

Z_k is a normally distributed variable, thus the values for the distribution function $f(Z_k)$ as well as its cumulated distribution $F(Z_k)$ are tabled.

The algorithm just described is the standard version proposed in literature [74]. This procedure stops when P_k is greater than P^* for a certain operation and the operation is the first one of the line: the algorithm considers this situation as unfeasible. To bypass this limitation, an extension of this method is proposed to parallelize stations. In case of an unfeasible solution, the station is split into different workstations that work in parallel. The new task time of the station is the task duration divided by the number of parallel workstation. The new standard deviation is kept constant.

The described algorithm is conceived for manual assembly stations. The calculation can be adjusted for automatic stations by setting the standard deviation of the tasks to zero or close to zero. The flowchart of the algorithm is shown in Figure 23. This method was chosen because the knowledge available from the case study perfectly fits to the input requests of the algorithm. This algorithm does not take into consideration re-working stations. And is conceived for single or multi-product assembly lines but not mixed-model assembly lines. However, more complex and complete algorithms can be implemented without changing the structure of the KBE system.

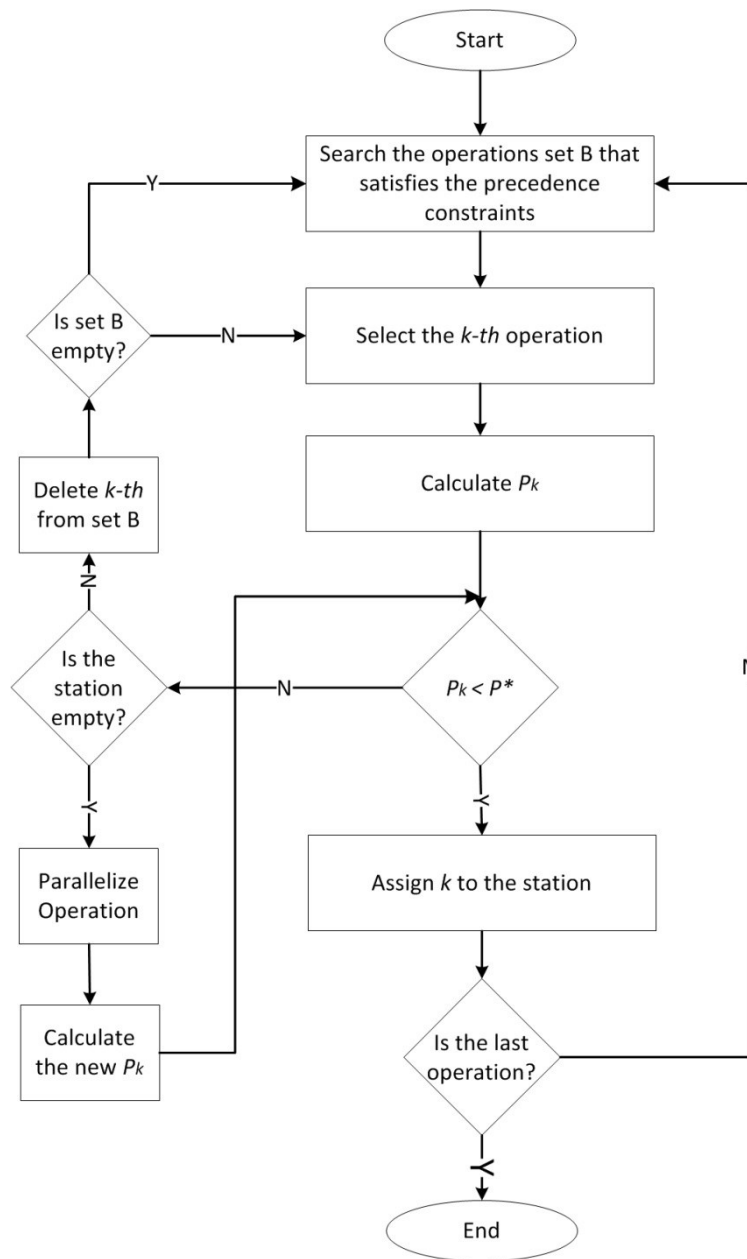

Figure 23: Graphical representation of the line balancing algorithm logic.

The assembly line balancing algorithm takes as input a set of defined times for performing the assembly operations. The operations reported in Table 3 are further detailed in sub-tasks. The times for performing a task are defined for each one of the possible automation levels (i.e. manual, semi-auto or automatic). In the case of multiple components the times of the tasks are defined for the single component and multiplied for the occurrences. For instance the insertion of valves, in the case of manual operation has a defined time for one single valve. The insertion time is multiplied for the number of valves (depending on the number of cylinders and on the type of cylinder head) and accounts for the total time of the task. The assembly line balancing algorithm is a more sophisticated solutions to the line configuration based on the selection of the automation level according to predefined cycle time thresholds. It is particularly important when it comes to complex assembly tasks or new operation sequences where pre-defined station configurations are not present.

Nevertheless, the present case study on a cylinder head assembly task presents both the option of a balancing algorithm or the selection of type of station based on pre-defined assignments.

5.4. Knowledge Integration

After the collected knowledge has been formalized, the structure of the KBE application is defined as well as the integration between the different functions of the applications (i.e. 2D/3D CAD, documentation).

In order to model very complex products and manage efficiently large bodies of knowledge, KBE systems largely tap the potential of the object oriented paradigm of their underlying language. The presented KBE application is written with Siemen Rulestream. Rulestream is a commercial off-the-shelf software based on Microsoft's Visual Basic.NET (VB.NET) platform and composed of two separate modules: (I) *Rulestream Architect* for definition of the KBE application structure and interactions with other tools; (II) *Rulestream Engineer* which is the module that the final user sees and interacts with. This section deals more with Rulestream Architect where the formalized knowledge is translated into a software architecture and all the modules of the applications are integrated. Section 5.5 will present more in details the Rulestream Engineer module.

The Rulestream architecture has three main features:

- *Part Families*: they represent the definition of a type of part. A part family have a set of attributes and rules which define the part. By assigning values to the attributes, or by calculating values for them, an instance can be created based on the definition of the Part Family.
- *Properties*: they describe a particular feature or attribute of a part family. Properties can be a constant, they can be calculated using a rule or a formula, they can be retrieved from a component database or they can be specified at runtime.
- *Subpart Collections*: they specify the parent-child relationship between part families. This relationship allows the part families to reference each other, and promotes a hierarchical tree structure of part families.

Figure 24 gives an example of the hierarchical order of part families and subpart (identified by the red brackets). The product architecture is built following a *top-down* approach and according to the acquired and formalized knowledge. As shown in the UML in Figure 17, conveyor stations and pallets are all children of the *line* part family.

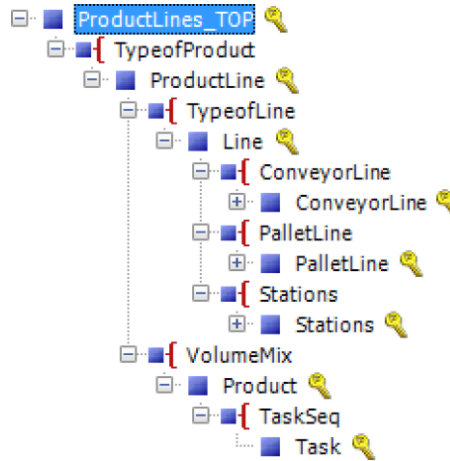

Figure 24: Hierarchical and object-oriented structure within Rulestream Architect

The properties are important attributes of the part family that can be manual or formula driven. In the case of manual properties the value is a direct user input and there is no default value. The formula driven property has a value which is the output of a defined formula. Each property has a name and a defined type (e.g. string, integer, etc.). The formula must return the specified data type and can contain a real VB.NET script. Figure 25 shows an example of the configuration window in Rulestream Architect for the definition of properties.

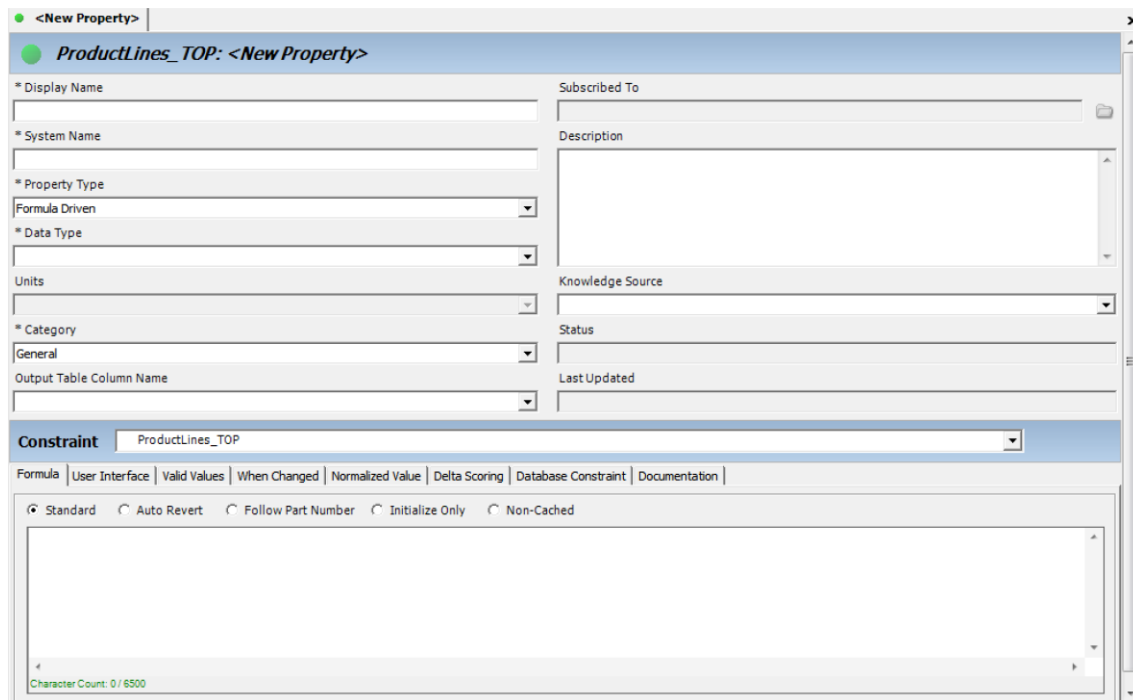

Figure 25: Rulestream Architect interface for properties definition.

5.4.1. KBE Modularity

The software for the KBE application has been conceived and developed following a modular approach. *Modular programming* is a common software design technique with the aim of

developing programs with independent and interchangeable functional modules. At high level these modules can be seen as *black boxes* connected by an interface module with which they exchange defined inputs and outputs. Modular programming has a great relevance at an industrial level for the software related to manufacturing systems design and execution. As a matter of fact, according to Fowler, one of the emerging grand challenges for the modelling and simulation of manufacturing system is the true Plug-and- Play interoperability of software within a specific application domain [75].

The presented KBE application is based on the modular approach shown in Figure 26. The user directly interacts with the main part of the application through a GUI. The main architecture groups together all the single modules that communicate between them and with the main module through interface layers. The modules presented in this thesis are highlighted in blue: CAD 2D, CAD 3D, Line Balancing Algorithm and Document Generator (i.e. Scope of Supply). The interactions between these modules and the main application are described in this section. The modules colored in light blue and surrounded by dashed lines represent the future integrations of the KBE application. These additional modules will be described in chapter 6. In particular, the layout optimization algorithm (sections 6.3 and 6.4) and the discrete event simulation (section 6.2). The upper part of the figure shows the high level configuration of the assembly line, which is the scope of this research study. Nevertheless, the logic of a modular configuration software can accommodate a lower level of configuration for the definition of the specific station equipment.

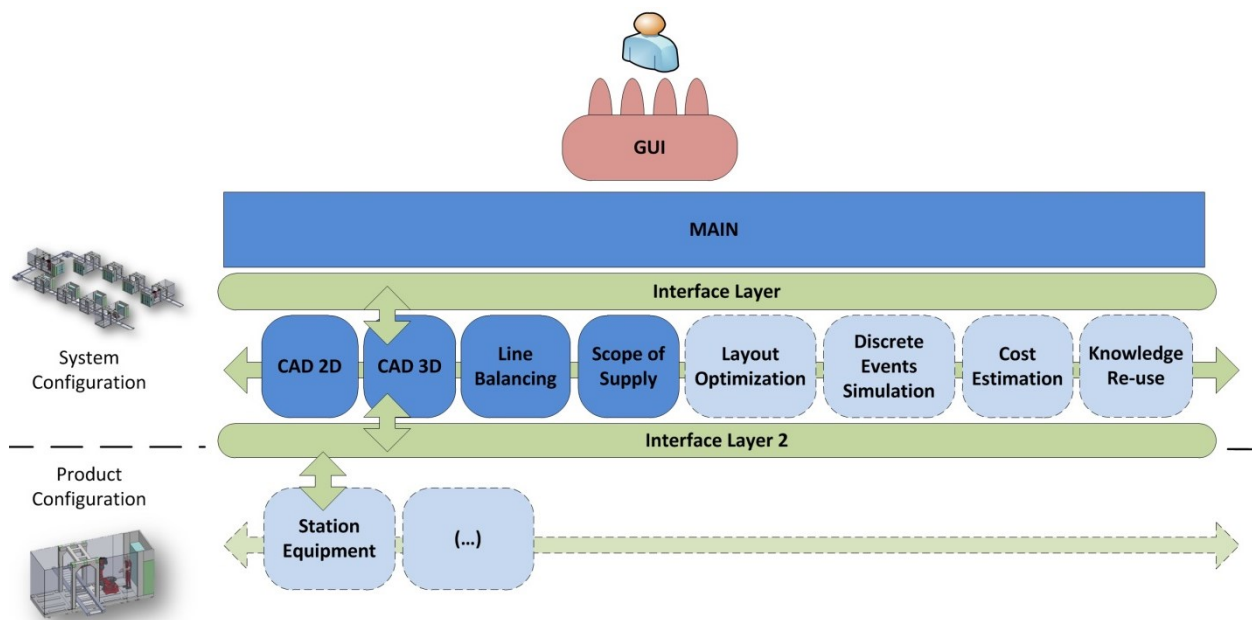

Figure 26: Modularity of the KBE software application.

The multi-level structure allows the KBE system to have both horizontal and vertical flexibility. The horizontal flexibility refers to adding some functionalities to the system (e.g. another generic module such as the *layout optimization* module) while the vertical direction refers to the improvement in the level of detail, from the high level line configuration to the station design.

The main advantages of a modular software design can be summarized by the following:

- Each module can be developed separately from others;
- Different users can work at the same time with the application;
- Modifications to one of the modules do not affect the rest of the application (i.e. this may except the interface module);
- Each module can be detailed without affect the higher level of the structure.

Indeed the main disadvantages are:

- The design of the structure plays a vital role and takes a long time;
- If the structure of the interface module is not well designed, there might be redundancy of information.

The external tools of the KBE application (e.g. CAD environments) are needed to generate the outputs of the configuration. The connection between the configurator and the CAD software is managed by the interaction with application programming interface (API) codes. These interactions will be described more in details in the following sections.

In a similar way, the relative documentation about the assembly line (i.e. bill of materials and bill of process) is generated by a common document generator integrated with the application. Figure 27 shows how the software configurator based on VB communicates via API interfaces with the CAD software and the document processor (i.e. Microsoft Word).

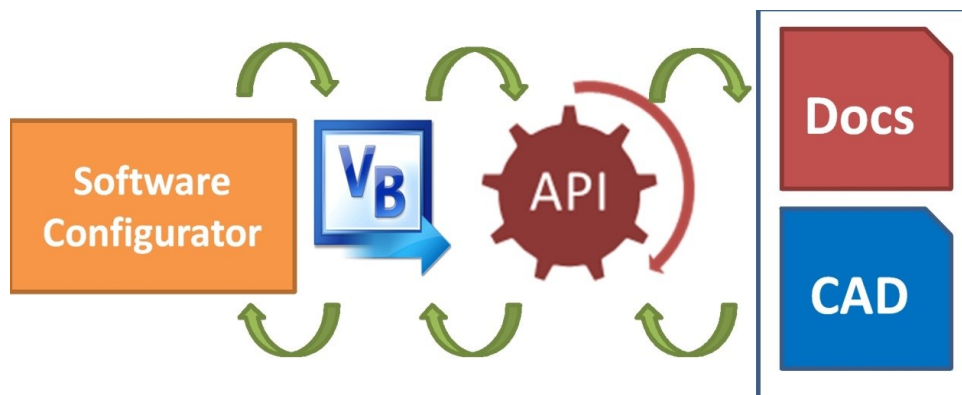

Figure 27: Interaction of the configurator with external tools

Interface Module - XML

As anticipated, the interface module between all the various packages of the software application plays a vital role and ensures the correct exchange of inputs and outputs between the functional modules. For the presented application, the *extensible markup language* (XML) has been used as the basis for the development of the interface layer. XML provides a foundation for creating documents and document systems and operates on two main levels: first, it provides a syntax for document markup; and second, it provides a syntax for declaring the structures of documents [76]. The XML is

derived from the Standard Generalized Markup Language (SGML) defined in the ISO 8879. The XML documents are made up of storage units called entities, which contain either parsed or unparsed data. Parsed data is made up of characters, some of which form character data, and some of which form markup. Markup encodes a description of the document's storage layout and logical structure. XML provides a mechanism to impose constraints on the storage layout and logical structure. Furthermore, the XML language is part of the XML Metadata Interchange that is a standard for exchanging metadata information through XML file. An XML-based system to exchange data between modules is suitable for the purpose of this application because it ensures:

- The *semantic interoperability*: the ability to automatically interpret the information exchanged (between two or more different systems) in order to produce useful results as defined by the end users of both systems (i.e. two generic modules).
- The *cross-domain interoperability*: the ability of two or more systems from different domains to interact in information exchange to achieve their own goals.
- The *syntactic interoperability*: the ability of two or more systems to communicate and exchange data. Specified data formats and communication protocols are fundamental.

For the specific application it is important to define the structure of the XML and which kind of data are contained in the interface modules. The data written in the XML file are the parameters that each module manages. A change in the structure of this file (or the adding of parameters) involves the modification of all modules connected to it.

5.4.2. Databases

Figure 28 shows the integration between the Rulestream Architect, the Databases and the CAD software (or in general the third part software). Using Microsoft's SQL Server 2008 R2, Rulestream Platform Server hosts three types of databases: the Rules Database, the Project Database, and the Component Database (optional). The properties of each part family have to be linked with the values contained in the databases. The Rules Database stores the captured knowledge of processes and rules. The Project Database stores actual requirements specific to each design, and also the state of the single project/design. The Component Database is optional, and it is independently created in SQL Server. It stores information on standard parts that are available for use within a design. For the purpose of this work, the KBE application uses all three databases.

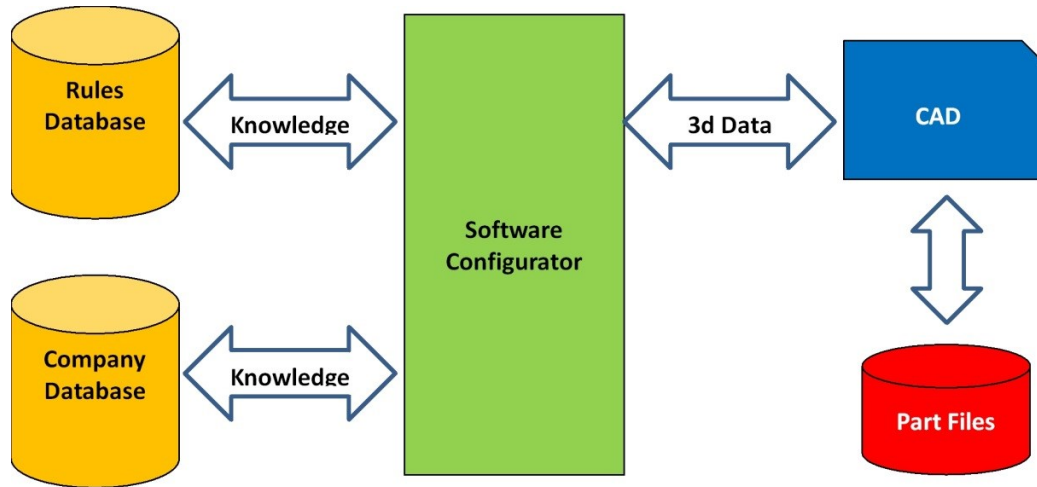

Figure 28: Integration of the configurator with existing IT tools.

Rules Database: it contains (I) all the information about the type of data (e.g. double, long, string, etc.) and the available command (i.e. VB.NET syntax) that can be used; (II) it contains all the technical information, for example about the units of measure; (III) it stores the structure of the application implemented in the Architect module: parts, properties, values, CAD files, etc.

Project Database: it contains all the information necessary to run the models during the configuration of the specific product. This repository supports the Rulestream Engineer module during the configuration: the data are taken from the other two database previously filled with the Rulestream Architect module.

Component Database: it contains all the data from company databases needed for the configuration. This repository is ideally the company PLM system. Nevertheless in this application is not integrated with the real PLM system but with a local drive configured as a PLM copy only with high level information. Two exemplary instances of the component database for this application are the conveyor database (dbo.conveyors) and the operations database (dbo.operations).

The "dbo.conveyors" contains the characteristic related to each conveyor module. The columns values are:

- Conveyor ID, product ID taken from the PLM;
- Conveyor Width;
- Conveyor Length;
- Conveyor Speed;
- Conveyor Type/Shape (e.g. straight, left/right curve, turning table);
- Conveyor Maximum Load.

The "dbo.Operations" stores information about tasks used for the line balancing algorithm. The columns represent the possible values of this parameters and they are:

- Product to which the task is related (e.g. engine, cylinder head, etc.);

- Operation ID;
- Description of the task;
- Machine that can perform this operation (automatic, semi-automatic or manual);
- The Duration of the task;
- The Standard Deviation of the task.

5.4.3. Interface with other tools

One of the crucial aspects of the developed application, is the integration with commonly used tools during the proposal engineering phase. Specifically, the application needs to be integrated with 2D and 3D CAD system and a report generator.

Rulestream has already some in-built integrations with different software tools. As a matter of fact Rulestream presents an interface with AutoCAD for 2D design and Solidworks (Dassault Systèmes) and NX (Siemens) for 3D design.

Rulestream does not include a default integration with all software tools available. For different tools the interaction between the packages of the application have to be developed (e.g. integration with MATLAB described in the following sections for the line balancing algorithm).

3D and 2D Layout – NX and AutoCAD

In the presented work, NX is the selected CAD system for 3D layout design. Similarly to other 3D CAD tools, NX is a parametric, feature-based solid modeling design tool that allows creating three-dimensional models of parts and assemblies. Since NX is parametric, Rulestream is able to drive the dimensions which govern geometry. The way to link Rulestream to NX is a property called *NX Specification*. An NX Specification provides a connection point between Rulestream and an NX assembly or part template. A part family can have only one NX specification.

Figure 29 shows the typical interface of this kind of property in Rulestream Architect. Two files *.prt* are necessary to generate the configuration: first (I) a NX specification is associated to each part family of the physical elements that compose the layout (i.e. "Station", "Conveyor" and "Pallet"). It contains the parametric model of the specific part; (II) the second file is a template file of the assembly linked to the top part of the Rulestream model. This template file is initially empty.

The CAD file of each part family was previously modeled. The CAD files of the components are simplified versions to allow the generation of an entire line layout without requiring too much computing power. Hence the two step for the generation of the CAD model are:

1. Link the parameters of the CAD model to the corresponding property of Rulestream.
2. Take the CAD file of the part configured at the step 1 and place it in the assembly CAD file.

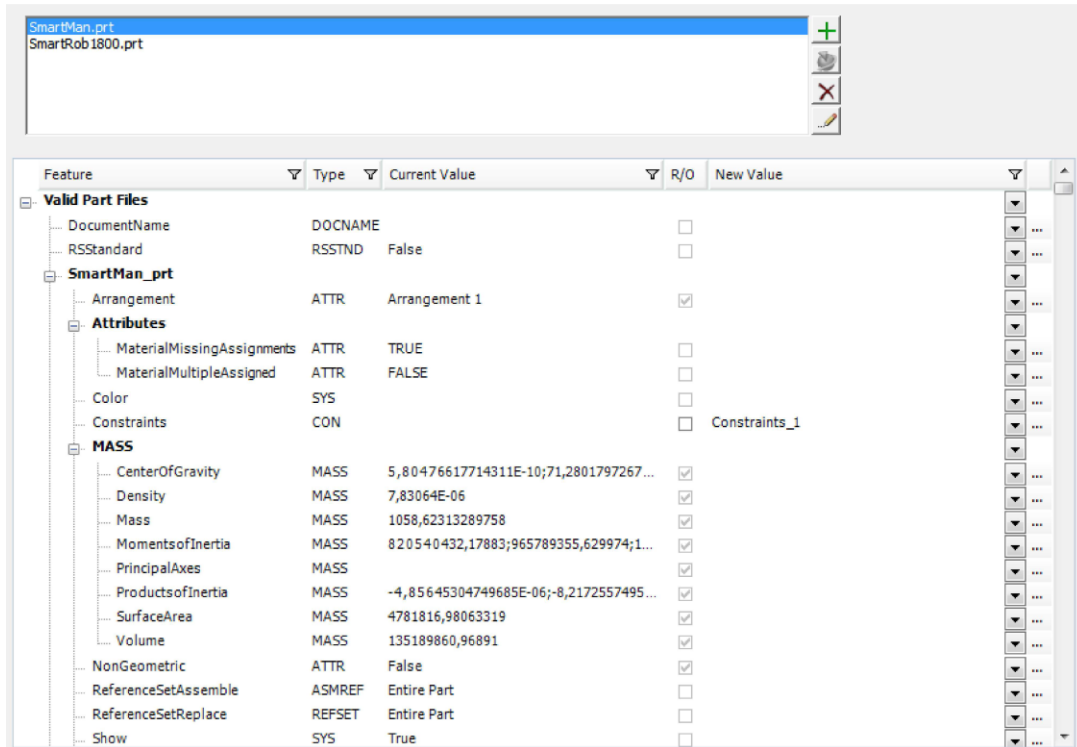

Figure 29: User interface for the NX integration of the application.

There are two ways to place the part in the assembly file: the first one (I) is based on the coordinates. A local reference system for each part is defined and the coordinates of this last one with respect to the global reference system are set; the second one (II) is based on the constraints. From Rulestream only two kinds of constraint can be assigned: the coincidence between planes or axis and the parallelism between planes. For this application the parallelism between planes has been chosen as the appropriate constraint as it is enough to define a line layout. Figure 30 shows the definition of the 3D CAD reference system of an automatic workstation, robot and conveyor module.

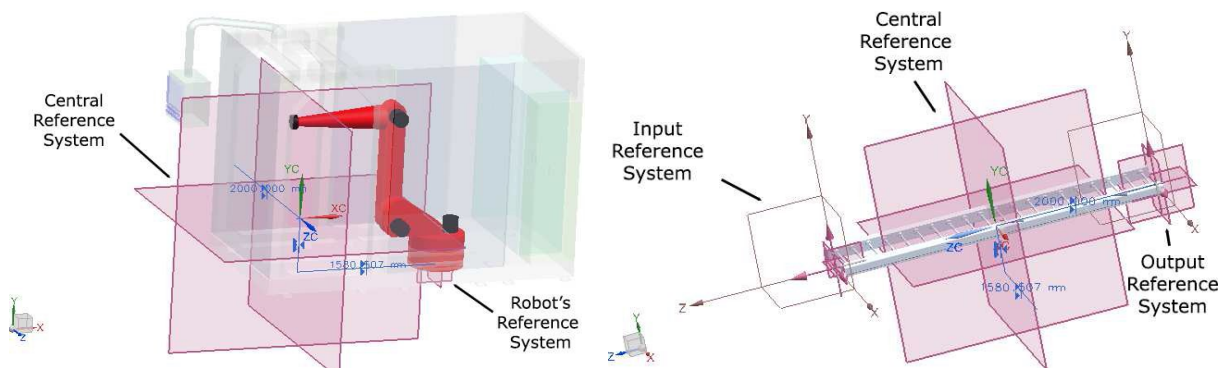

Figure 30: Example of reference plane for an automatic station and a conveyor module.

The following steps need to be performed in order to set the specification for the correct positioning of the equipment into the layout:

1. The NX specification of the station module is added to the "Station" part family.
2. The "Constraint" property is created in the same part family. In the formula tab of this property there is a script that specifies the constraint between the plane of this station with the previous part (that can be for example a conveyor). If the station is the first one of the layout, then the constraint will be between the inlet plane and the plane of the global reference system.
3. The property is linked with the constraint attribute of the NX specification.

The script contained in the property "Constraint" is the following:

```
Result = ApplyManager("NX","Touch Align",me,"Plane","XY",
me.BackwardConnection(1),"Plane","XY","")

Result &= ApplyManager("NX","Touch
Align",me,"Plane","XZ",me.BackwardConnection(1),"Plane","XZ","")

Result &= ApplyManager("NX","Touch Align",me,"Plane","ZY",
me.BackwardConnection(1),"Plane","ZY","")

Result &= ApplyManager("NX","Touch Align",me,"Plane","T4-500
L3000.XY_IN",me.BackwardConnection(1),"Plane","XY_OUT","")

Result &= ApplyManager("NX","Touch Align",me,"Plane","T4-500
L3000.XZ_IN",me.BackwardConnection(1),"Plane","XZ_OUT","")

Result &= ApplyManager("NX","Touch Align",me,"Plane","T4-500
L3000.ZY_IN",me.BackwardConnection(1),"Plane","ZY_OUT","").
```

The first three lines contain the procedure to fix the inner conveyor of the station to the station itself: the two central reference system are aligned. The last three lines align the input reference system of the inner conveyor of the station to the reference system positioned to the output of the precedent part ("me.BackwardConnection(1)").

The same procedure applies to the other components of the line and to the generation of the 2D layout. Section 6.1 deals more specifically with the synchronized generation of 2D and 3D layouts of the assembly line and the software tools used for this purpose and that will be integrated into the KBE application.

Document Generator – Microsoft Word

Rulestream Architect has a pre-defined integration with Microsoft Word. Likewise the layout generation, the positioning of texts and images is performed mainly with bookmarks. Text can be assigned dynamically and images can be changed based on defined rules. Existing or custom styles can be specified for each image or text that is placed in the document. The *Microsoft Word Specification* requires a template file. The template will typically contain bookmark locations, and often some static text or images (e.g. the logo of the company) that are common to any generated report. There are four types of Word Specifications:

1. The *Word Specification* defines the template that will be used to create the final document. It must be created in either the same part family that contains the Word Paragraph and Word Image specifications, or any parents above it. A template file has to be specified.
2. The *Word Paragraph Specification* defines the text that will be placed in the final document. It must be created in either the same part family containing the Word Specification, or any subpart below it. The text in the paragraph can be static (i.e. a predefined text) or dynamic (i.e. linked to a property). The position is related to the bookmark position in the template file.
3. The *Word Image Specification* defines the image that will be placed in the final document. The Image Specification must be created in either the same part family containing the Word Specification, or any subpart below it.
4. The *Word Table Specification* allows the application to insert tabular data in final documents. The number of the columns is set by the properties linked to the table. The number of the rows depends on the quantity property of the part family in which the table is allocated.

Figure 37 shows an example of a typical document generated as output by the KBE application.

Assembly Line Balancing -MATLAB

The linking between MATLAB and Rulestream is implemented using VB.NET APIs script and XML metadata. The script freezes Rulestream during the MATLAB run-time avoiding possible interferences of the user. The defined procedures allows the interface module to read and write four different XML files:

1. The XML named "Input.xml" contains all the information useful for the assembly line balancing. This file has to be written from Rulestream.
2. The XML named "Constr.xml" contains all the technological constraint related to the operation involved into the balancing procedure. This file is written from Rulestream and read by MATLAB.
3. The XML named "ALB.xml" contains the configuration of the line balanced. This file is written from MATLAB and read by Rulestream.
4. The XML named "LogicalLayout.xml" contains all the information about the line configured, it is a report of the configuration. This file is written from Rulestream at the end of the configuration process. It will be used in the future to retrieve the information about this project.

The algorithm used for the line balancing and implemented in MATLAB is detailed in Section 5.3.4.

5.5. Knowledge Implementation

As described in section 0, the application has been developed in Siemens Rulestream® [59] following the previously defined formalization. The process of line configuration follows the steps defined by the designers during the knowledge retrieval phase.

The interaction with the application is ensured by a Graphical User Interface (GUI), with some suggestions and thumbnails. The user interacts with the GUI that facilitates the configuration of the system by using decisional points, process steps and alerts or suggestions. The user goes step by step through the configuration process answering the questions presented by the application.

The output of the KBE application is a complete overview of the preliminary design of the system: it includes 2D and 3D layout linked with the scope of supply (i.e. bill of materials) as shown in Figure 37. Section 0 discusses more in detail the outputs of the application. This section goes more into the details of the application, showing the Rulestream Engineer step by step through the graphical user interface presented to the user.

The first step of the configuration is the initial window shown in Figure 31. The user has two main options: (I) starting a new line configuration or (II) entering a database of past projects for retrieving information on existing lines. Currently the *past projects* choice allows the user to access a database of projects documentation: mainly line description and 2D CAD layout. However, KBE systems have the higher aim of using past knowledge to avoid re-engineering efforts. This mechanism is usually implemented in KBE systems by using similarity measures. While the user configures an assembly line the KBE system may be able to retrieve related data or similar projects in its internal database. In future work this will be implemented. As of now, there is only a static repository of past proposal designs.

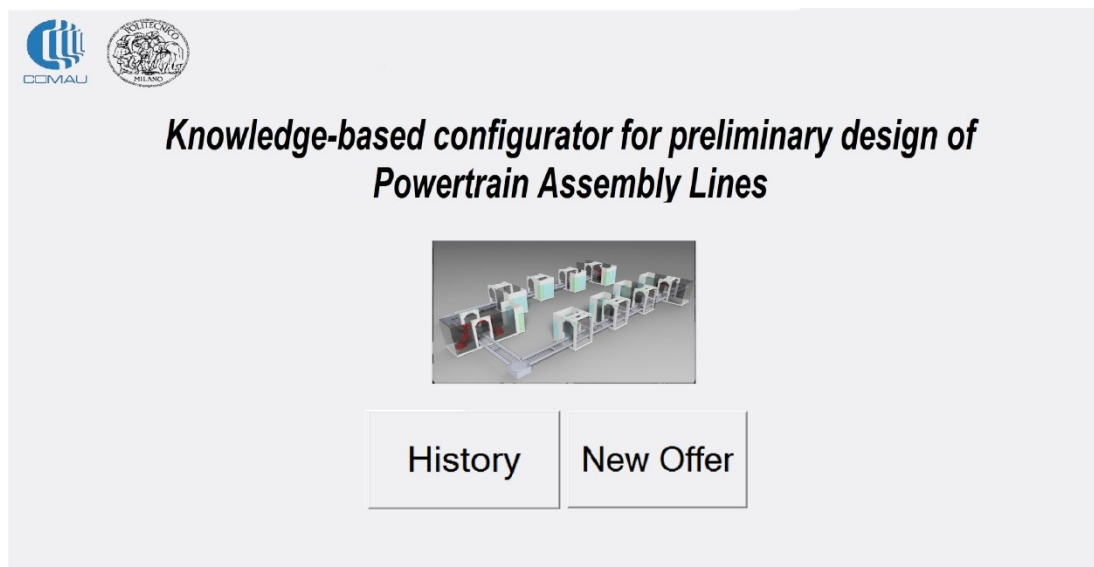

Figure 31: Starting window of the KBE application.

If the user selects the *configure a new line* option he/she is redirected to the window shown in Figure 32. During this second step, the user is asked to fill the general information part of the new assembly line which is being quoted. This includes the selection of the customer, the region and

country where the line will be installed, and the product that will be assembled. The selection of the product is important as it recalls from the operation database the list of tasks needed for the assembly and its precedencies. Similarly the selection of the product features will influence the time needed for completing the task and consequently will affect the line balancing procedure. The GUI is configured so that when the choices of the user change a corresponding thumbnail appears on the right hand side of the window (i.e. country map, product type and customer logo). Nevertheless it is always true that the GUI can be easily customized by a user with no specific programming skill. In a similar way, other info can be added on top of the one required.

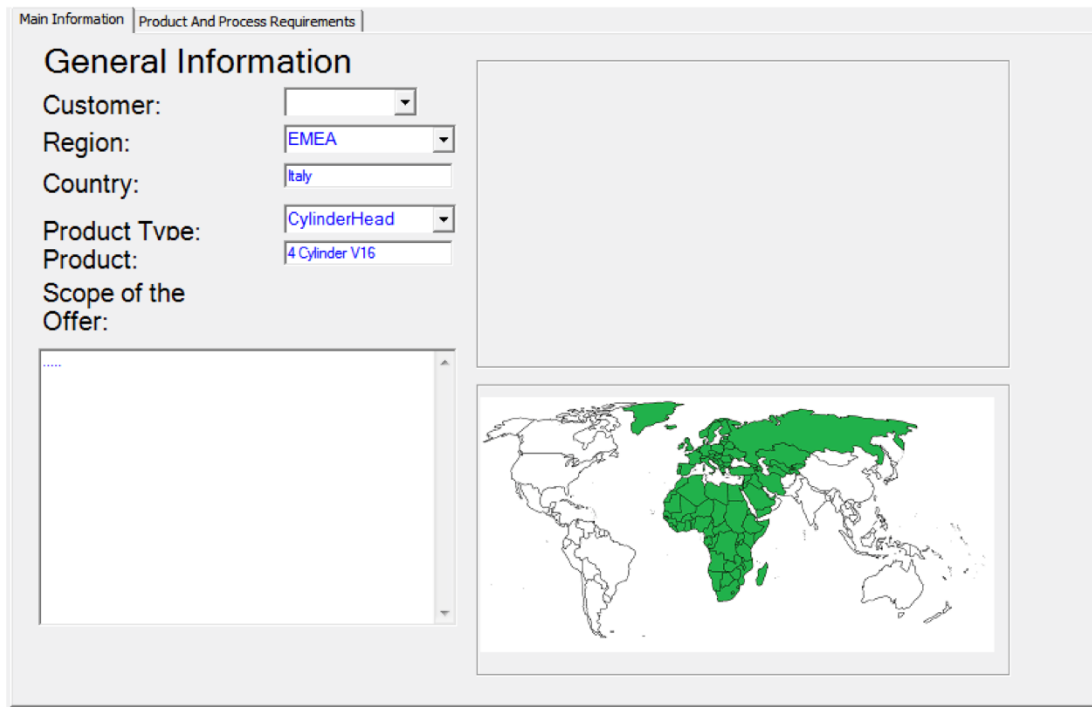

Figure 32: General Information window of the application.

The second tab of this same window named *Product and Process Requirements* is shown in detail in Figure 33. The user can list different variants for the same product type. For each variant the user can specify weight, width, height and length (expressed in mm): these variables together identify the so called “envelop area” which is used for the dimensioning of the conveyor system and the dimensions of the station. In this example the configuration is limited to one single variant which can be managed by the line balancing algorithm.

As seen in section 5.3.4, the cycle time is a critical value for the configuration of an assembly line. The cycle time of the line can be calculated starting from different assumptions. Usually cycle time is not a value defined a priori by the customer but is obtained from the annual production rate taking into consideration the number of worked hours and the desired technical efficiency. In this application, the starting point is the daily production rate. Considering the number of shifts, the hours per shift and the technical efficiency we can derive the cycle time that will be the maximum threshold for assigning tasks to the workstations. In the formulas below, technical efficiency refers to downtime due to station failures and micro failures. Instead, the definition of management efficiency refers to production losses due to poorly managed resources on the shop floor (e.g. lack of

preventive/planned maintenance, lack of skilled operator to restart/repair the machine in case of failure). The technical inefficiency of an assembly line is typically attributed to the system provider (e.g. Comau), while the customer (e.g. OEM) is responsible for management inefficiencies.

$$Takt\ time = \frac{Total\ time\ available\ in\ a\ working\ day}{Daily\ production\ requested\ by\ the\ customer};$$

$$Cycle\ time = Takt\ time \times Technical\ efficiency \times Management\ efficiency;$$

In the same window the user is asked to express the desired flexibility of the line. Flexibility is a critical feature for assembly line and big capital investments in general as it represents the ability to accommodate in the future different models of the same product with the lowest possible effort of line re-configuration.

The choice of flexibility could also be a rule associated to the selection of the regional features of the assembly line. For instance, it can be assumed that an assembly line for high production volumes (i.e. low cycle time) intended for a low labour cost country can be associated to a low cost technical solution. This assumption is not always supported by the real-world assembly line production. Therefore the KBE application leaves the choice to the user who can manually change the flexibility/cost of the configured solution. Table 6 shows an example of the different type of technical solutions available for the performance of an operation of the cylinder head assembly process. Noticeably, by changing the assembly operations the different types of pre-defined technical solutions change and so do the possible choices of flexibility levels.

Table 6: Examples of flexibility levels of different technical solutions for an operation of a cylinder head assembly.

Operation ID	Low cycle time		Medium cycle time		High cycle time
	High cost/High flexibility	Low Cost/Low Flexibility	High Cost/Automated	Low Cost	Base solution
70 - Assemble valve stem seal washer	Automatic (Robot)	Automatic (Gantry)	Automatic (Robot)	Semi-Auto	Manual

The last configuration step of this window regards the physical layout of the assembly line. As seen in Table 5, the suggested layout shape is guided by the OEM customer that has some preferences or requirements. Nevertheless the choice can be modified by the user. In addition, if available during the proposal phase, the user can input data about the available floor space where the assembly line will be installed. These data will be used when the number of stations and conveyor is defined, combined with the layout shape to verify a feasible fit between the line and the available space. For instance if the available length is 50 m, the selected layout shape a straight line but the line has 15 station with a 4m conveyor module the solution will be highlighted as non-feasible suggesting a different layout shape or a left/right turn.

Main Information **Product And Process Requirements**

Variants: 1

ID	Cylinders	Valves	Weight [kg]	Width [mm]	Height [mm]	Length [mm]	Daily Production [job/day]	%	Cost_Flex
A	4	16	80	450	400	800	800	100	Low Cost & Defe...

Production Time [h/shift] : 7,5 Cycle Time [s/job] 37,5

Working Shifts: 1

Technical Efficiency: 0,9

Suggested Layout: U-Shaped

Plant Area

Length 100 m

Width 110 m

Area 11000 m²

XmlWrtEnabler

Next

Figure 33: Production volume and product requirements.

By flagging the *XmlWrtEnabler* option the application generates the XML file that will be taken as input by MATLAB for running the line balancing procedure once the button *Next* has been clicked. The application is frozen while the algorithm is running. At the end of the algorithm the user sees a dialogue window about the outcome of the procedure (i.e. successful or not).

The following configuration step, shown in Figure 34, is the operations cockpit where the various operations are grouped into the workstations and assigned to the selected machine. The *Operation Editor* tab (Figure 35) allows the user to change data regarding the stations. Similarly, the *Conveyor* tab (Figure 36) regards changes to the line conveyor. The XML file generated in output by the MATLAB algorithm is updated with the manual changes performed in these last two tabs.

When the configuration procedure is finished the application generates the output of the designed line: 2D and 3D output and line description. The output of the application shown in Figure 37.

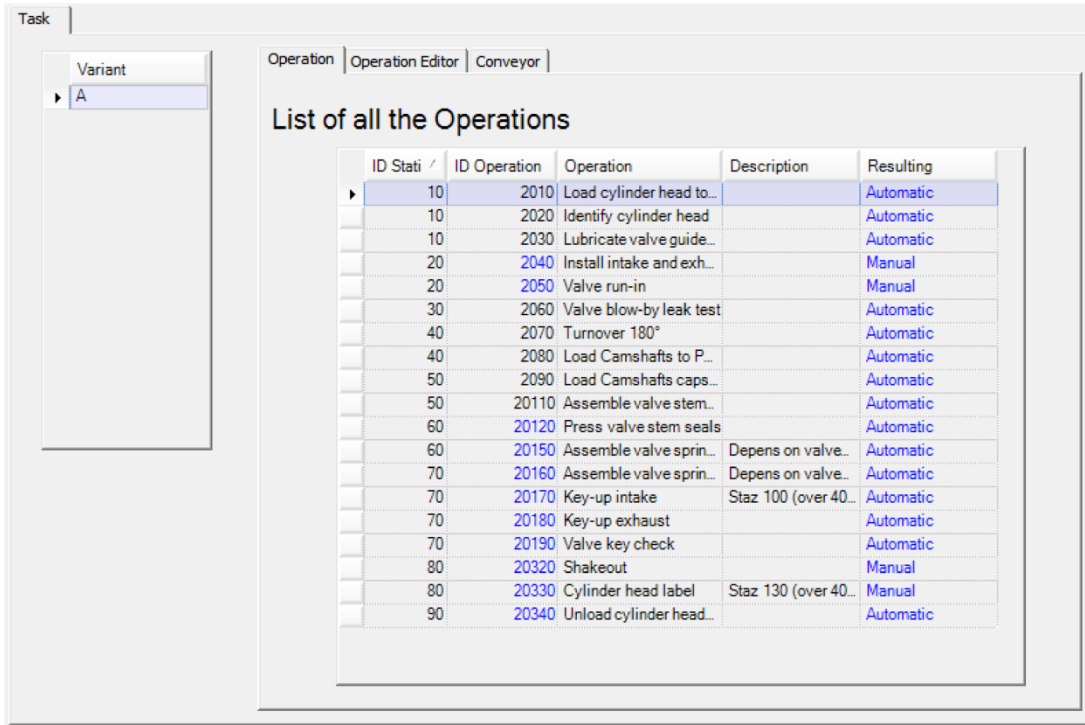

Figure 34: Operation Tab

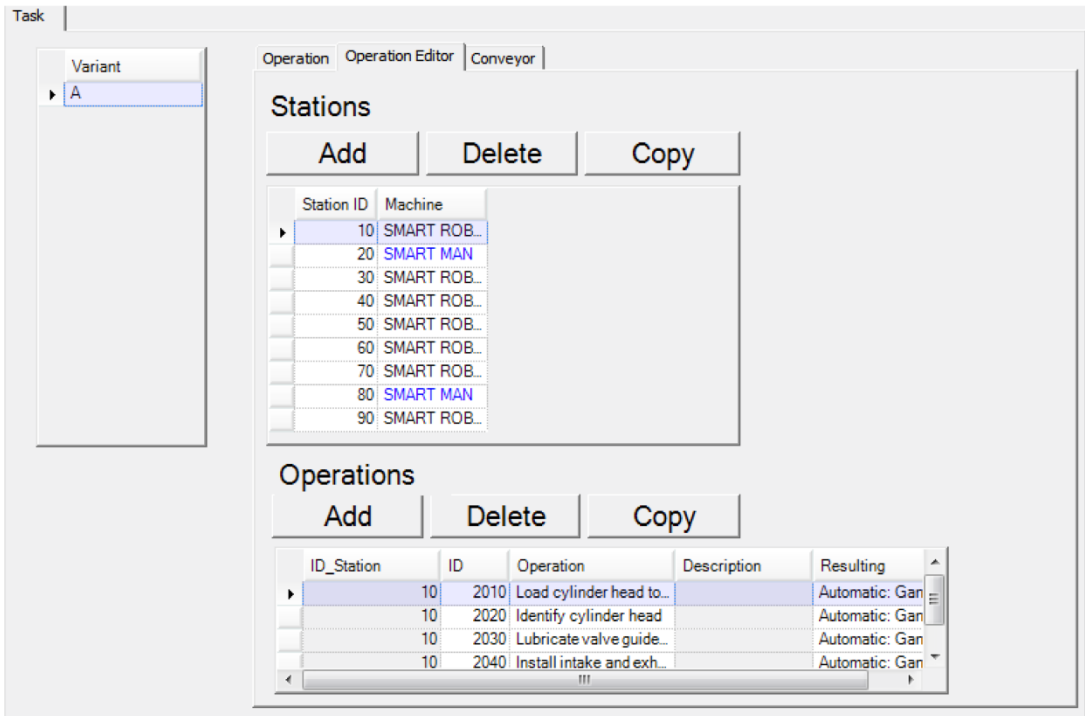

Figure 35: Operation Editor tab.

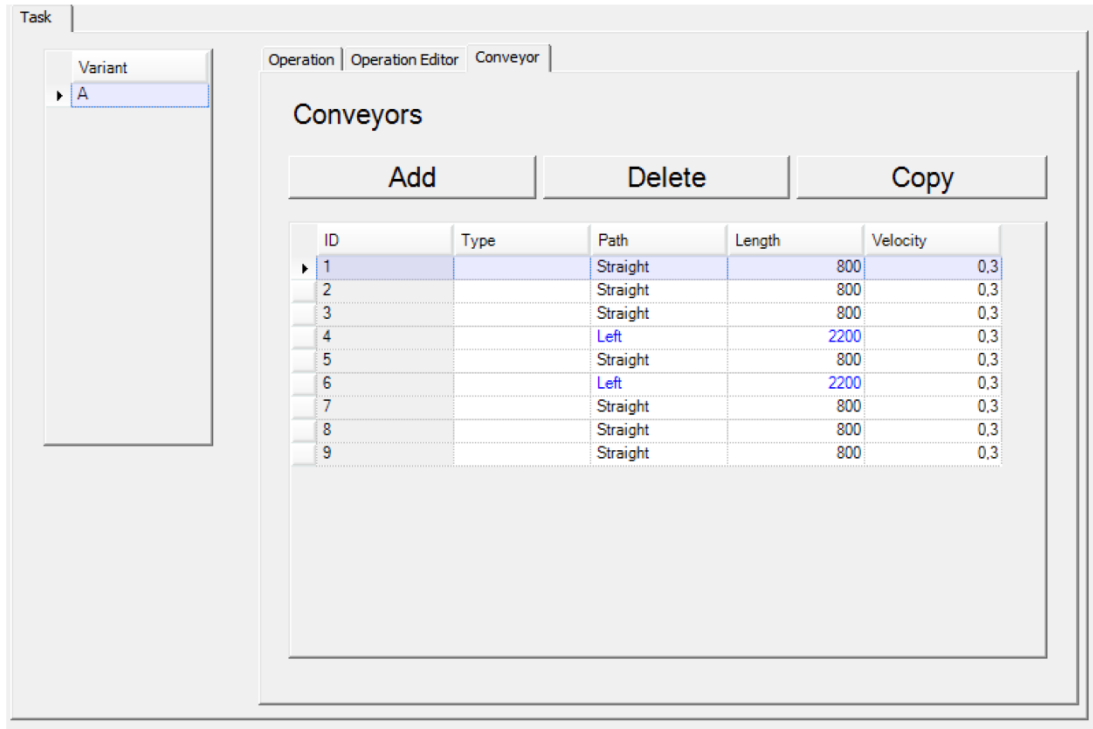

Figure 36: Conveyor tab.

Application - Knowledge Implementation

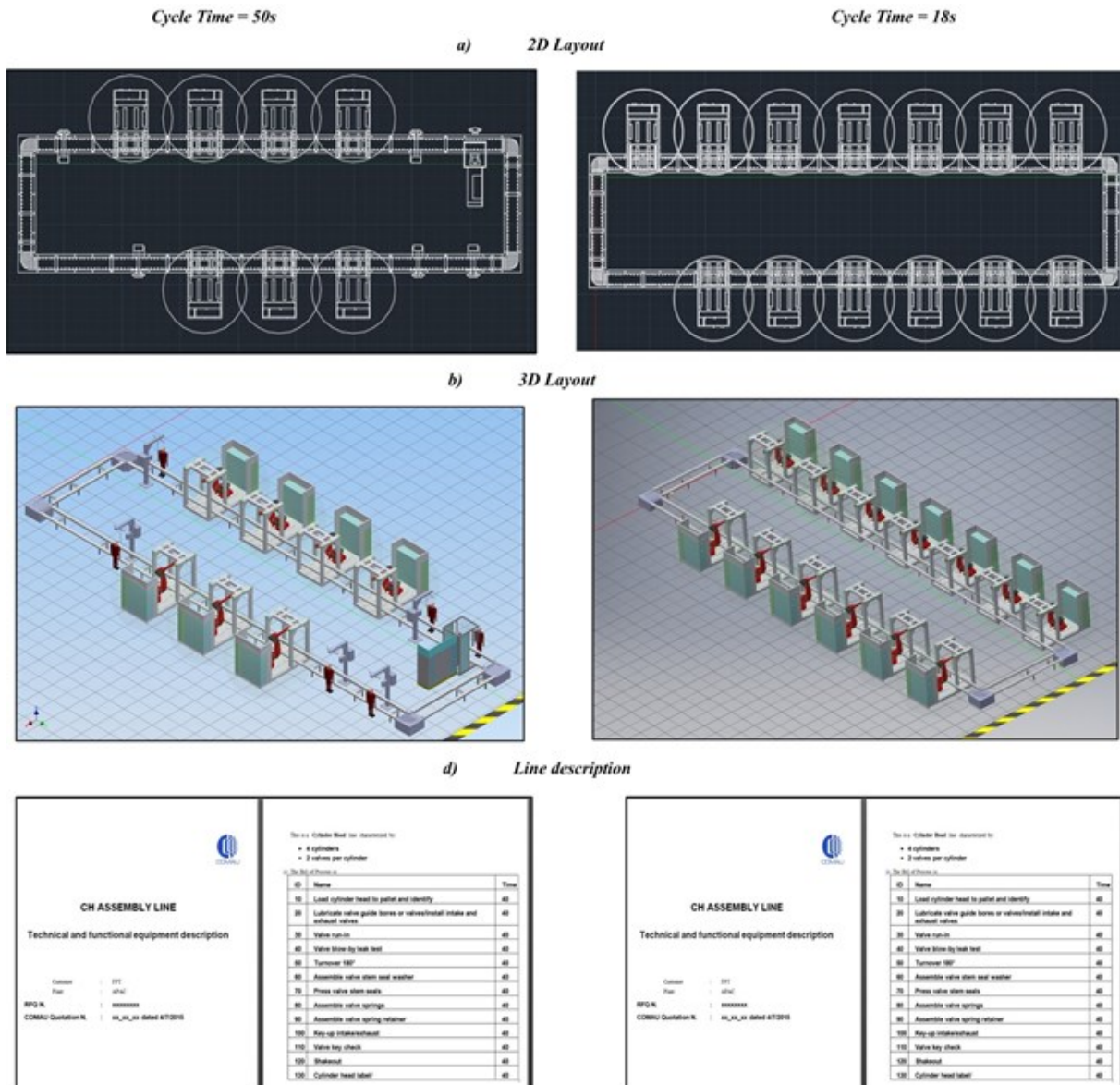

Figure 37: Output of the KBE application for a cylinder head assembly line with different cycle times.

5.6.Evaluation

The evaluation of the tangible benefits given by product configurator systems is considered to be a difficult task. Some authors consider the application of this system and the testing in a real industrial environment as a viable solution to evaluate possible benefits.

Most configuration and KBE literature focuses on technical solutions and methodologies, while only a minor part of this literature focuses on empirical studies of the benefits from applying these approaches. Hvam et al. [77] present a review of examples in the literature of evaluation of configurator approaches. In particular Ladeby [78] describes the application of the benefits of product configuration to engineering companies. This thesis has the aim of both presenting and applying a structured methodology and validating empirically the implemented solutions.

The evaluation proposed in this research work is based on 4 main *pillars*, shown in Figure 38:

1. **Lead Time**

The reduction in lead time is considered by the literature the most tangible effect of the implementation of a knowledge based configurator application. Lead time reduction is much higher if we consider the integration of the DES model (section 6.2.1).

2. **Resource Consumption**

One of the main aims of design automation projects is to reduce the consumption of resources for performing repetitive design task. This does not mean shifting the entire workload from men to machines, but leaving more space for added value and creative work.

3. **Quality of Design**

Quality of design can be evaluated in several ways. However quality is a difficult aspect to measure as it can be defined by a subjective evaluation of the receiver. The *quality pillar* includes both better optimization of the system to customer requirements and a reduction in the number of mistakes in the design.

4. **User and Customer Satisfaction**

The satisfaction of the user is an important index for the evaluation. Nevertheless its nature is mainly subjective and sensitive to customer perception.

The test have been performed on the developed KBE application for the configuration of a cylinder head assembly line. The evaluation scheme proposed is applied to the pilot test performed.

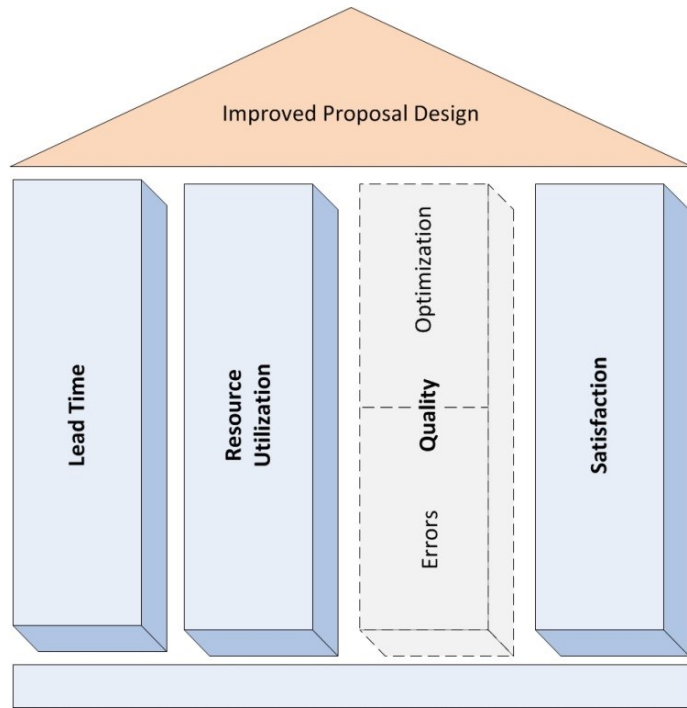

Figure 38: The four evaluation pillars of the methodology

5.6.1. α Test Case – Pilot

As anticipated, a test has been carried out to validate the reliability of the implemented methodology. The same actors involved in the KA phase were participating in the test with their different competences. The main element of the test is the comparison between the design supported by the knowledge based configurator and the traditional design process using existing procedures. In the first case, two designers were using the KBE application while in the traditional design process more actors with different competences were involved in the design process. The object of the design was the cylinder head assembly line. At the end of the design, all the participants, including designers that used the traditional approach but took part in the development of the application, were asked for direct feedback on the new KBE approach. We collected three main positive and negative feedbacks and we asked the participants whether they agreed or not with the statement. Table 7 shows the participants roles and the results of this test in terms of worked hours and participants feedback.

1. *Lead Time*

The replacement of the traditional approach, which relies mostly on tacit knowledge and experience, with a systematic capture of existing knowledge and automation of repetitive design tasks can lead to an estimated reduction of around 30% of current design times. The traditional design approach of a cylinder head assembly line took 1 full-time week. Nevertheless this time span increases proportionally with the complexity of the assembly line being designed. Usually, the time for a proposal design can be stretched in rare cases to 2 or 3 days for a very simple cylinder head assembly line. However, in the case of full engine assembly lines, the entire proposal may take up to 3 weeks in the worst case scenario. These numbers are estimates made by the same proposal engineers and designers. Figure 39 shows the estimated time saving based on the test performed on

the design of a valve train assembly line starting from the same Request For Quotation (RFQ). The reduction in design time can result in a larger amount of design output being generated in a relative shorter time span [38].

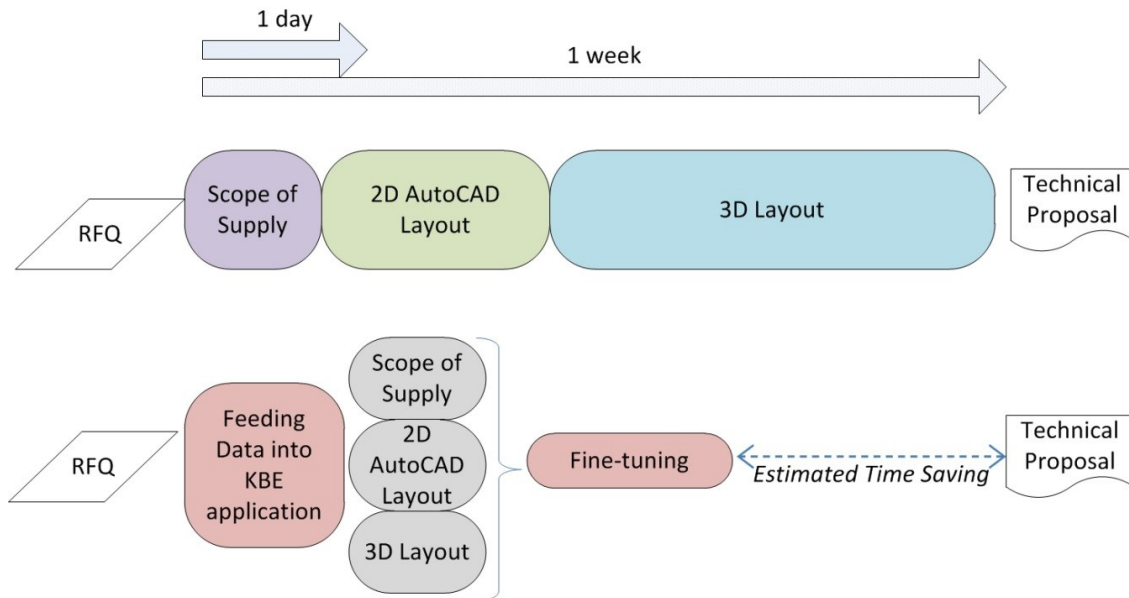

Figure 39: Estimated time saving for the preparation of a technical proposal of a powertrain assembly line.

2. Resources Consumption

This new approach can lead also to a reduction of the number of resources involved in the process. In the traditional approach functional blocks have various styles because they represent tasks carried out by several actors with different competences: 2D layout designer, 3D layout designer and proposal engineer. Currently in Comau, 2D layout design and proposal engineer competences are common to the same designer. Typically experienced designers have the adequate knowledge to design the line but they are used to work only with 2D CAD (AutoCAD). On the contrary, 3D layout design is a more specific competence and typical of new hires, used to work with various 3D CAD systems but lacking proposal experience. Section 6.1 goes into details of 3D CAD tools for layout design and some of the issues that make 3D layout design a task requiring different competences from 2D design.

3. User and Customer Satisfaction

Table 7 shows the qualitative feedback on the tests performed. The evaluation of the customer satisfaction is referred both to the first/internal customer of the KBE application (i.e. proposal engineer or designer) and to the external customer (i.e. automotive OEM). For the purpose of this research it was not feasible to test the satisfaction of the external customer, due to the prototypal stage of the application. For the calculation of the possible benefits of a knowledge based system configurator, the better satisfaction of customer requirements is taken as an expected but non verified benefit. In fact, it is believed that applying the concept of automation to engineering can lead also to an increased customer satisfaction thanks to a shared output with the customer from

the initial design steps. However, the aim of the internal test was also to verify the impact of the system configurator on the users themselves. The answers reported in Table 7 show a positive impact of the new technology. Among the positive aspects, almost all the participants fully agree on the ability of a KBE application of significantly reducing design times. At the same time, the designers and engineers interviewed see a great benefit in the possibility of quickly exploring different design alternatives (i.e. β test Case). The aspect related to the knowledge re-use is less seen as a benefit of the application. This may be due of the not fully integrated knowledge re-use functionality. At present, in fact, the application only works as a knowledge repository without automatic recognition of similar features or line archetypes. On the contrary, the interviewed participants identified a series of negative aspects. Among them, the limited capability of output generation is considered as a weakness of the new technology. As a matter of fact the great rigidity of the output is mostly related to the 3D layout. The 2D layout generated in AutoCAD is a widely accepted format for 2D design and does not represent an obstacle. On the contrary, the generation of a 3D layout in NX format may cause some troubles as it is a CAD tools not commonly used by the interviewed designer. Furthermore, some of the participants see in the KBE application a threat to creativity due to the discussed rigidity which includes also the definition of rules which evolves constantly at a fast pace. Finally the issue of intellectual property was raised by some of the participants. They fear that the formalization of design rules in an automatic platform could lead to more optimized solutions that can be copied by competitors. However, this problem is an intrinsic risk of competing bids and applies also to traditional design processes.

Table 7: Feedback results of the preliminary test.

	TIME (Hrs)		FEEDBACK					
	Usual Approach	KBE Approach	Positive			Negative		
			Shrinks design times	Helps evaluation alternatives	Useful for knowledge re-use	Limits creativity	Too Rigid Output	Intellectual property at risk
2D Layout Designer	8	0						
3D Layout Designer	16	12						
Cost Engineer	8	0						
System Engineer	8	0						
Proposal Engineer	0	16						
TOT.	40	28		Fully Agree		Neutral		Strongly Disagree
				Agree		Disagree		

4. Quality of Design (Less Errors and Optimization)

The reduction of design mistakes is one of the main aim of a knowledge based configurator. The errors that can be avoided are at three different levels:

- *Design mistakes:* the main aim of knowledge based design is to avoid re-engineering of technical solutions. The re-use of already tested solution reduced the probability of errors in the design. However, at this high level configuration the design of the machines has little influence on the quality of the design. Nevertheless already existing layout solutions can be re-used with the necessary adjustments reducing the risk of errors and reworks.
- *Detail mistakes:* these are typical human errors due to lack of focus. These include typos in the technical description of the system as well as simple mistakes in the CAD tools (e.g. wrong mates or positioning).
- *Quotation mistake:* these are mistakes that can negatively influence the good outcome of the proposal. The quotation activity is highly error-prone as it deals with a lot of numbers and list of hundreds of equipment. The typical mistakes during these phase can be very serious. However the integration of the configuration tool with the estimation tool with a one to one correlation between the elements used to configure the line and their price can

help to tackle this issue. Similarly to design mistake, the quotation is much more important the deeper it goes into the detail of equipment. At present however the configurator does not support this integration.

Nevertheless in this first evaluation it was not possible to quantify the increase of quality reached with the proposed approach. The output of the application for this test is shown in Figure 37. The repetitive tasks are executed by the application and can be considered as error-free. Provided that the output generation rules of the application are correctly defined by the programmer the output will be executed by the application without detail mistakes.

The benefits in terms of reduction in quotation mistakes will be evaluated once the application will be integrated with the estimating tool (i.e. currently an excel file with complex macros and routines). On the contrary the reduction in design mistakes is not so relevant at this level of abstraction. Nevertheless the comparison between a traditional proposal and an automatically generated one at a detail level can only be made during the detailed engineering phase, this means when the proposal was successful and the project has already started.

The current KBE application, as most of the existing applications in the field, is CAD specific. The interaction between Rulestream and the CAD software is integrated into the KBE package by the developers. Currently, the supported CAD tools are Siemens NX and SolidWorks. It is possible to implement the KBE package with interfaces to other CAD tools but requires an effort by the developers and it is not up to the user. As highlighted by Salchner et al. [79] for the automotive industry is important to be able for automotive suppliers to deal with different CAD system as every OEM has different requirements.

Figure 40 summarizes the effects on the four *pillars* of the evaluation after the α test case.

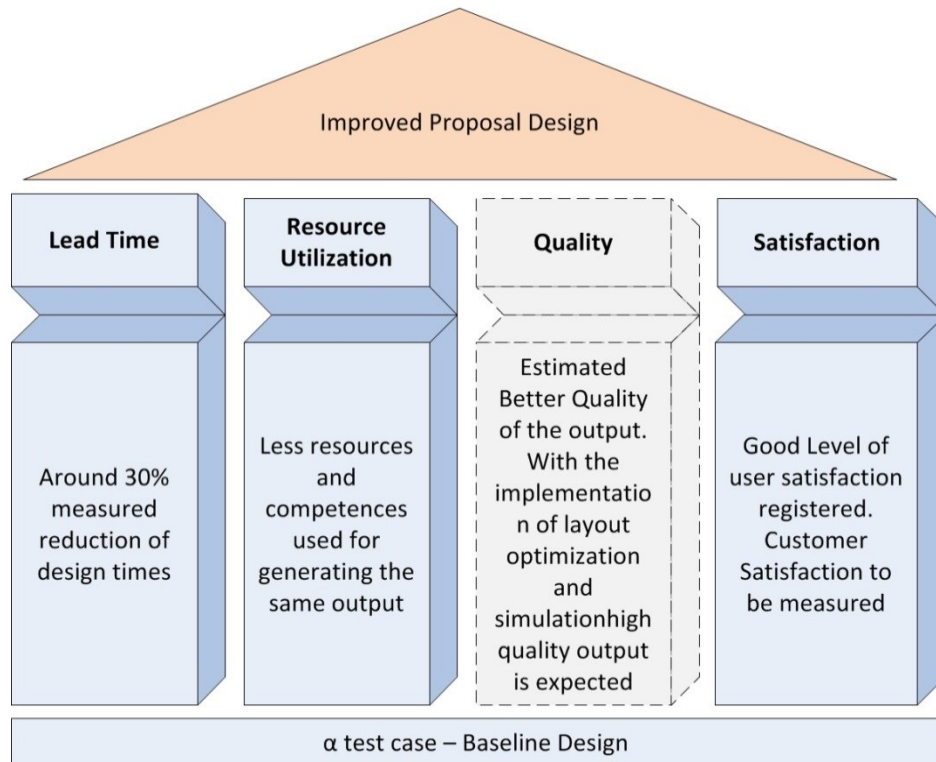

Figure 40: The four evaluation pillars with respect to the α test case of the application.

5.6.2. β Test Case – Design Alternatives

Design requirements may evolve over time both during the proposal and the detailed engineering phases. Changes in the requirements or the evaluation of different design alternatives can negatively affect the design in terms of time and cost. Some of these changes simply required part of the design to be re-worked, while others required not only a re-work but a substantially greater amount of design work. In an interesting paper, Williams et al. investigated the effect of design changes during large engineering projects using system dynamics [80]. Their assumption can be transferred to almost every design activity where changes in the specifications creates feedback loops that lead in the end in an increased delay in design activities. Figure 41 explain the concept of feedback loops in a system dynamic model. The main negative loop of the model is formed by a design change that leads to more work to do that, in turns increases the delay of the project. A delayed project implies more parallel activities with less resources that result in an increased duration of the activities and an always more delayed project.

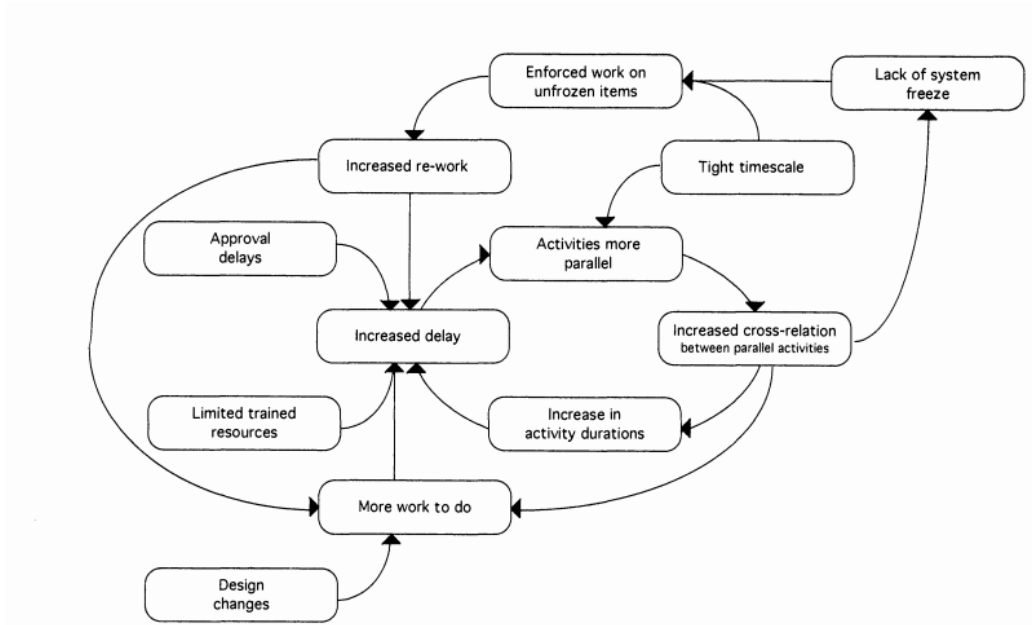

Figure 41: Feedback loops created by design changes during engineering projects (taken from [80]).

Exploring different design alternatives can result in significant design delays. This assumption is mostly true when talking about repetitive design tasks and large non-specific designs. In the case of big layout designs, from a technical point of view, small changes are amplified and can mean several hours of additional work. These adjustments made on big and somewhat repetitive layouts are low-added value activities, perfect target for design automation.

Therefore, one of the aims of our evaluation was to consider the *what-if* scenario: “*what if there are changes in the initial requirements or the evaluation of different design alternatives is required? How the design is improved with respect to the traditional approach?*”.

The possible changes in the requirements can be of very different types. For this test, we took as an example a very simple modification in the production rate of the designed assembly line. This change affects mainly the choice of the level of automation of some workstations.

Figure 37 compares the outputs of two cylinder head valve assembly line configurations: one with a medium-high cycle time and one with a very low cycle time (i.e. typical of high volumes production lines). All the other constraints of the configuration are kept the same with the only modification of annual production volume and the relative line cycle time. The absence of manual or semi-automatic stations in the second solution can be noted.

- *Lead Time*: the modification of an existing layout is a time-consuming activity. With the traditional approach and the production rate modification it took an entire day (i.e. 8 hours) to modify all the three outputs (i.e. line description, 2D and 3D layout); this was possible provided that the resources with the right competences were available on that day. The same change implemented in the KBE application was performed in less than 1 hour, drastically reducing the design time.

- *Resources Utilization*: modifications to the design require of course the intervention of the same skilled people that started the design in the first place. If the designers in charge of implementing the changes are not the same of the first design, the modifications are likely to require a longer lead time. The KBE application is free of this *personalization of design* and can be run by different designers with the same design procedure and outputs.
- *Quality*: the same concept applies both to the α test case (base solution) and the β test case (design alternatives). The quality of the design has not been quantified, but it can be imagined that the automation of the task will lead to a reduction in errors, provided that the configuration rules are correct. As a matter of fact, an update of the initial design is likely to overlap with other activities already programmed. This would force the designer to focus on more parallel activities at the same time with the risk of a decrease in quality.
- *Satisfaction*: the request for changes put on the designer additional stress and pushes him to work on different tasks at the same time have to parallelize work. The benefit on the user satisfaction increases when it comes to update an existing design. Proposal designers and engineers interviewed confirmed that they would like an automatic system to help them in updating or changing designs more than they do when the design starts from scratch.

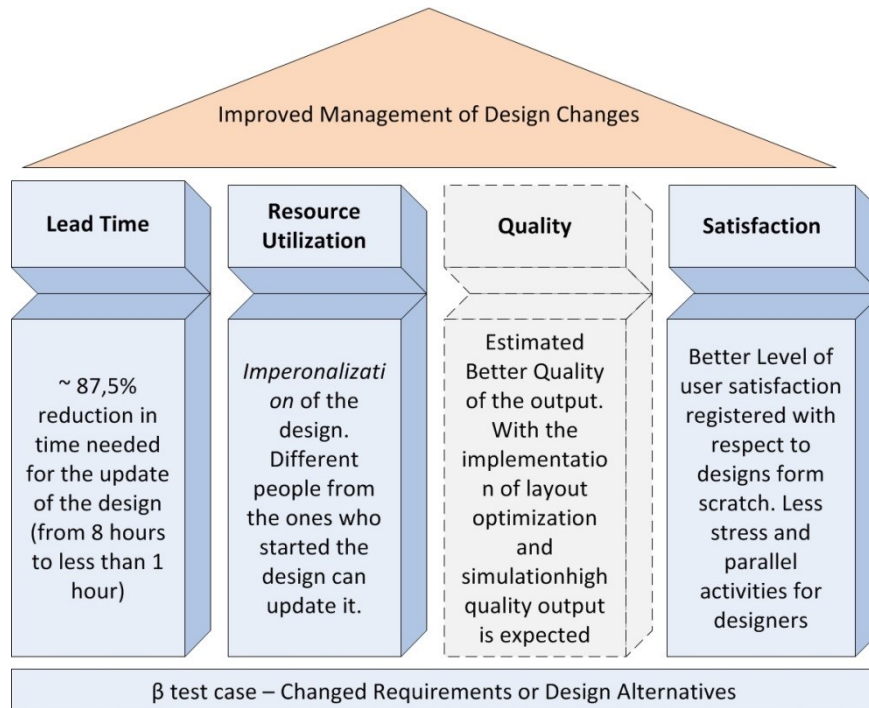

Figure 42: The four evaluation pillars applied to the case of design changes.

5.7. Business and Organizational Case

The previous chapter discussed the benefits of the new approach. In this section the study tries to translate the identified benefits in terms of revenues and costs to build a solid business case for the adoption by industries. We identified four main critical success factor areas for the implementation of a KBE approach based on the analysis carried out by Suryanthono [81]. At a company level these four factors should be positively aligned for the success of KBE implementation:

- *Organizational factors*: including management support, company culture and clear definition of strategy and objectives with the right employee motivation.
- *Resources/Training*: including the definition and training of resources in charge of set-up and maintenance of the KBE system. This factor includes the right education of engineers and designers to ensure a smooth change from current design systems to the new approach. This implies of course the acceptance of the need of a new professional figures with specific competences and skills: the knowledge engineer.
- *IT Infrastructure*: this includes the adequacy of the IT systems and the ability to integrate easily with the variety of commercial design tools used in an engineering company and the several output formats of design activities.
- *Performance Indicators*: the success factor considered as the most critical is the measurement of the performances achieved with the new KBE approach. Of all the critical success factors, the evaluation of the benefits is seen as the most important. If some performance improvements are reached, benefits are expected in other success factor areas and especially management support is more likely to lead to a successful implementation of the new design approach.

In the literature, there are several implementations of KBE in industrial environments and identifications of the benefits. However, apart from some exceptions [82, 83] there are virtually no papers that discuss benefits versus cost. The first step for performing a business case analysis is to have clear the actors that have some interest in the introduction of the new design approach within the company. The different stakeholders can be classified on different graphs based on their interest/power or simply listed according to their involvement as in Figure 43.



Figure 43: Stakeholder map with regards to the development of a KBE application

5.7.1. Cost-Benefit Analysis

The cost-benefit analysis described in this sub-chapter refers to the experience described in this thesis. The framework of the analysis is therefore limited to the scope of the methodology and the application developed within this research programme. The cost-benefit analysis is based on a two-year time frame and on the KBE application built with the commercial off-the-shelf tool used for this research Siemens Rulestream. Section 5.7.3 gives more detail on the commercial software tools available on the market for building design automation applications. One of the aims of this analysis is the definition of a preliminary return on investment (ROI) from the introduction of the new KBE approach.

- **Benefits**

The primary benefit of this preliminary application is the reduction of the design time (i.e. around 30% in the case of designs starting from scratch). Nevertheless the benefits for design changes is much higher (around 87%). For this reason the calculation of the return of investments for this application is based on an hour count. However for the cost benefit analysis, the 30% reduction in lead time is taken as a good approximation of the expected benefits.

The analysis is based on an hour count thus it is difficult to take into account the benefits not related with a lead time reduction (i.e. quality improvement and better user satisfaction). These hours/costs are difficult to estimate as there are also indirect benefits expected: given the time saving thanks to KBE, additional hours will be used to improve the dexterity of the designers with the new system. Several findings have proven that IT-enabled time savings are re-invested in new product features development and in a general improved design quality [84, 85].

- **Costs**

The Total Cost of Ownership (TCO) quantifies all costs associated with the purchasing process. The cost of the acquisition and subsequent use of an item or service that has been purchased is determined. The approach goes beyond the simple price of the product/service and considers all the costs over the items entire life [86]. The TCO is an index commonly used for the calculation of costs of IT software and infrastructure. It is composed of 4 main elements:

- i. Costs for the purchase of hardware and software components (including administrative costs for benchmarking analysis) In this specific case, this item includes all the costs for the acquisition of the software package to implement KBE application and integration with existing IT infrastructure;
- ii. Costs for software customization;
- iii. Operative costs for running and maintaining the application (including training costs, energy costs, internet connection , end user assistance, IT security etc..). In the case of the KBE application, this item includes the non-negligible costs of maintaining and updating knowledge bases;
- iv. Costs for closing down the system ;

The development of the presented application accounted for 3 man months. This includes all the steps of the methodology and the work of the knowledge engineer and software engineer, whose salaries at a company level are similar. The developed application only covers a restricted area of powertrain systems assembly lines (i.e. cylinder head). It is estimated (Table 8) that the development of a complete KBE application covering different powertrain products will need additional work up to 27 man month (accounting for almost 21000 hours). For this analysis we introduced a custom defined “complexity index” that works as a simple multiplication factor for the application development required man months. The index ranges from 1 (low complexity) to 3 (high complexity).

Table 8: Time needed for the application development

	Complexity Index	Man Month (Knowledge Engineer)	Man Month (Software Engineer)	Total Man Month
Cylinder Head	1	1	2	3
Engine	2	2	4	6
Transmissions	3	3	6	9
Suspensions	3	3	6	9
				27 (21000 hours ca.)

- **Return On Investment**

We estimated for the proposal engineering department a total expenditure of 70.000 design hours per year, a value that reflects the current company structure. In this case, the estimated yearly time

saving (i.e. 30%) is roughly comparable to the hours needed for the implementation of a complete KBE application.

If we use for the comparison only the design hours we can estimate that a return of the investment will be achieved at the end of the first year of the implementation (Figure 44). In this case, after the break-even point, using the same application, time savings will be effective with a direct annual ROI of around 30%. This preliminary ROI calculation takes into account costs and benefits related to design hours. At this point we chose not to introduce a financial analysis as it would be tied to the specific software tool. On the contrary, the aim of this study is to give an evaluation of the benefits to the design phase of a KBE configurator approach rather than benchmarking different software tools available in terms of licenses costs and service.

However if we tried to introduce some indications about the viable costs for the company we could use a reverse approach to define a target cost for the implementation of the KBE approach. In this case, if we consider an hour cost of *50 €/hour*, which bears with it all the overheads and company costs, we can multiply by the annual estimated hours saved (i.e. 21000) and obtain a value around *1 Mio €*. This value can be considered as the threshold for investments on a two-year time frame. It includes all the cost for licensing, operating and maintaining the software tool at a global level. This investment in fact is to be considered on 70000 design hours which means around 38 designers/engineers. The amount of design hours thanks to the use of the KBE application is reduced by 30% which leads to 49000 hours and around 27 designers and engineers that should have access to a significant number of licenses compatible with their needs. These licenses will be managed at a global level by the ICT department.

It is easy to imagine the importance of an anticipated evaluation of the cost-benefit analysis for a KBE implementation. Retrospective or ex-post cost-benefit analysis is important for understanding and communicating positive results but at the same time it can be used for better prospective or ex-ante cost benefit analysis. If a prospective analysis manages to consider all the right assumptions in a relatively short future period it can be a useful tool for better and anticipated decision making at a company level.

Cost-benefit analysis is a conceptually simple analysis but can be very difficult in practice; calculating the costs is a fairly straightforward endeavor, but quantifying the benefits of a knowledge based system is less quantifiable. Nonetheless, it is this precise difficulty which makes performing such an analysis vital, if carried out correctly, it can be an ideal tool for creating a roll-out strategy or a strategic proof of concept.

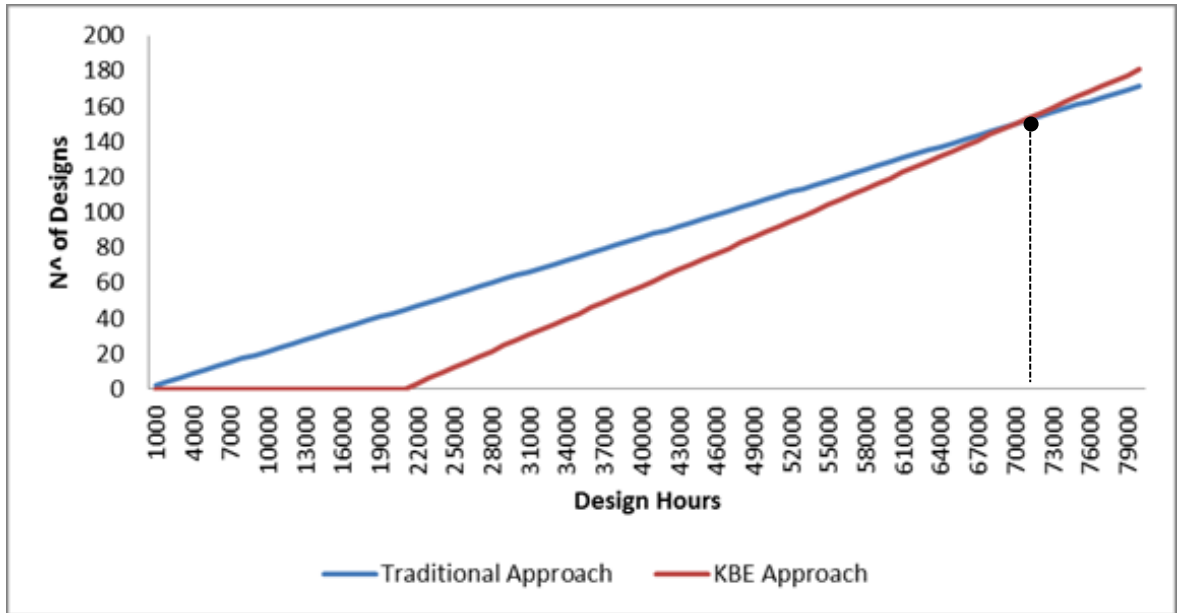

Figure 44: Estimated return on investment in terms of design hours.

To verify more in detail the benefits of the investment a NPV (Net Present Value) should be performed. This is only a preliminary analysis to see if there is the opportunity to build a solid business case.

5.7.2. SWOT Analysis

Taking into consideration the analysis carried out in the previous sections, the Strengths, Weaknesses, Opportunities, and Threats (SWOT) framework can be used to classify favorable or unfavorable factors to the adoption of KBE technologies within manufacturing systems preliminary design phase. The SWOT analysis, despite its simplistic structure and lack of diagnostic capacity is a largely adopted and recognized framework. Strengths (S) and Opportunities (O) gather those factors that are favorable to the implementation of a KBE approach, while Weaknesses (W) and Threats (T) mention aspects unfavorable to the new design approach. Strengths and weaknesses of the solution are considered internal, while opportunities and threats faced by the system are mainly due to changes in the external environment. Strengths and weaknesses are intrinsic to the KBE application and approach and have been highlighted in the previous sections. On the contrary, opportunities and threats regard more the interactions of the designers among them and with customers. Some of the points raised by the designers during the qualitative evaluation of the application are reported in these two elements.

The outcome of the SWOT analysis is summarised in Table 9.

Table 9: SWOT analysis for the applied KBE approach.

Internal	Strengths	Weaknesses
	<ul style="list-style-type: none"> - Reduces design times eliminating repetitive design tasks - Helps designer and engineers reducing errors and improving their level of satisfaction - Stores newly generated knowledge - Provides a robust design output at a global level 	<ul style="list-style-type: none"> - Requires programming skills - Strongly depends on the quality of the knowledge base and engineering rules collected (needs to be updated and maintained) - Lack of integration with all engineering tools (cannot generate all types of output required)
External	Opportunities	Threats
	<ul style="list-style-type: none"> - Can improve collaboration between designer between different Comau premises - Can improve communication with the customer from the early stage design increasing the number of successful proposal. - Can be expanded to a web-based application with direct user/customer interaction 	<ul style="list-style-type: none"> - May put at risk some of Comau intellectual property and design knowledge - Designers and engineers may negatively react thinking that automation of design tasks can lead to a reduction of the workforce

5.7.3. Market Outlook

After several developments, KBE systems never really became an industry standard despite being always a popular research and industry topic. In the last decade, with the great advancements in CAD capabilities, many software houses are introducing KBE additional modules on top of their design tools. The aim is to increase the level of design automation to avoid repetitive design tasks and focus only on value added activities.

Figure 45 shows the evolutions of the main KBE systems (blue coloured), the main KBE vendors (black coloured) and the more recent configurator-like tools (coloured orange). Apart from Genworks GDL/Gendl and Technosoft AML (Adaptive Modelling Language), which are possibly the only true KBE systems on the market, all the others are basically KBE-augmented CAD systems, where a true KBE language (e.g., SiemensNX, Knowledge Fusion) or some sort of KBE capabilities (e.g., Dassault Systemes CATIA V5 Knowledgeware) have been integrated to augment the core CAD functionality. The major differences between these augmented CAD systems and true KBE systems is that the first are CAD centric, i.e., a CAD engine is always present and running, and the automation focus is largely geared towards geometry manipulation. Hence, no data processing can occur or any kind of algorithm can be implemented that is not related or directly embedded in the definition of some geometrical object. True KBE systems, on the contrary, focus on more holistic knowledge and information manipulation, and they do not even include a real CAD kernel in their basic package, although one can be acquired under an extra license. In spite of the not always orthodox KBE nature

of many of the new tools on the market and the questionable absorption processes carried by the big PLM companies, there are some incontestably positive consequences on the diffusion of KBE.

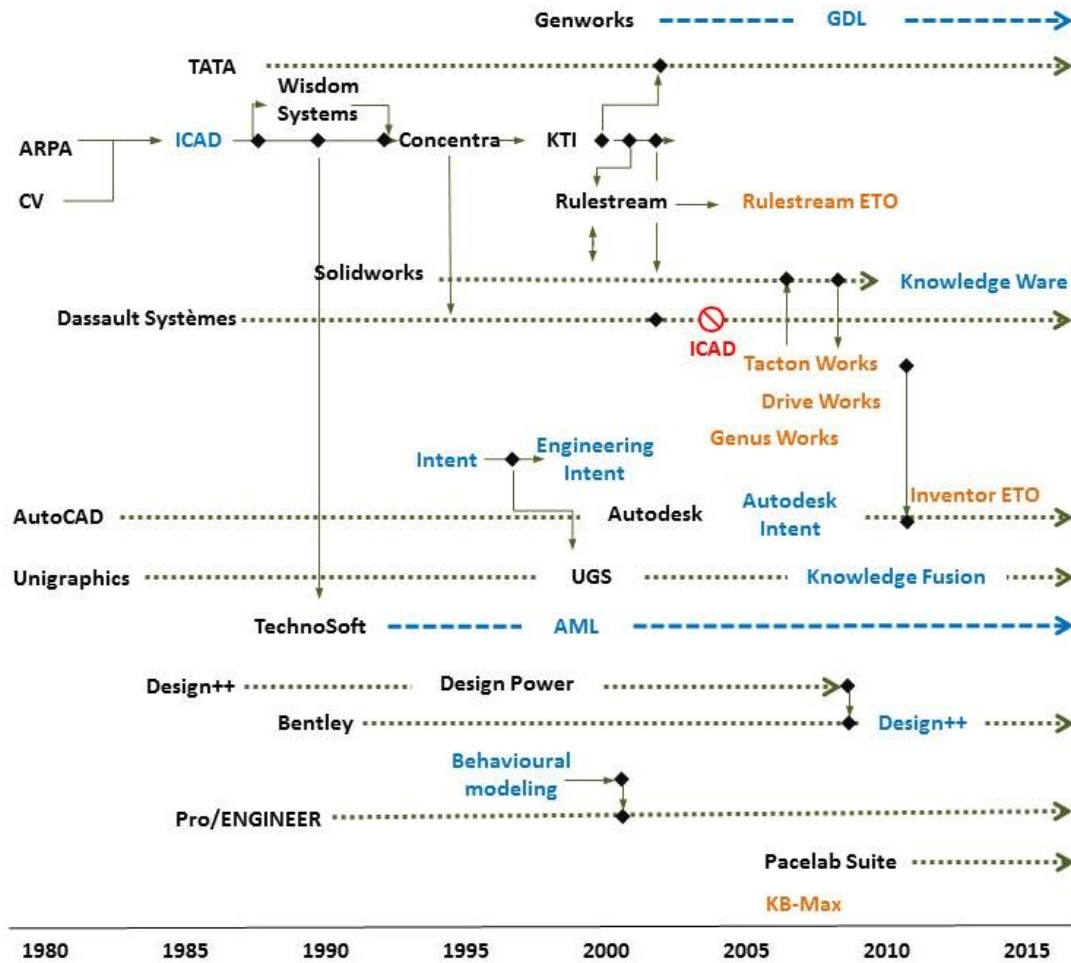

Figure 45: Review of KBE software packages over time adapted from [33]. Coloured black, and followed by dark green arrows the main KBE vendors. The main KBE languages are represented in blue. The KBE most recent software packages that focus on sales support are coloured orange.

Most of the most recent tools have a strong focus on the sales and commercial aspect. Other tools have instead a strong focus on the web based technology. Table 10 lists the main KBE software packages available on the marketplace. The first part of the table reports the software tools more focused on an integrated approach from the design to the sales phase: these are the so called ETO (Engineering-to-Order) software tools. These tools are the best fit for the assembly line configuration case study since the integrated output is typical of a sales configuration rather than an automated design. The bottom lines of Table 10 report some of KBE tool specifically focused to the design automation and usually integrated in existing CAD tools. The information in Table 10 has been collected from the internet and also re-elaborated from Reddy, Sridhar et al. [87] and from [88]. All the reference of the cited software tools can be found at the end of this work.

A part from the main software houses, the market of KBE has many actors that offer services of KBE application implementation and development using various existing tools and methods.

Table 10: Main KBE commercial software tool.

Software Tool	Developer	Features
Rulestream Engineering-to-Order	Siemens	not directly built on a CAD software but is already integrated with NX and other software tools. The tool is designed to implement the Siemens PLM software package.
Inventor ETO	Autodesk [89]	Inventor ETO (Engineering-to-Order) has a strong focus on the sales automation as well as on design
Tacton Works Engineer	Tacton [90]	one of the most recent software tool promising to automate both design and sales with a possible web-based approach.
KB Max	Citius Software Corporation [91]	automatically generates all required outputs like CAD models and drawings, pricing and quotes, BOMs
Design++	Design Parametrics [92]	ETO configuration software
Drive Works	Drive Works [93]	Supports both design and sales configuration
Adaptive Modeling Language	Technosoft [94]	an object-oriented, knowledge-based engineering modelling framework
Genus Designer	Genus Software Inc. [95]	design automation tool conceived for SolidWorks.
Pacelab Suite	PACE Aerospace Engineering and Information Technology [96]	Aerospace industry specific engineering tool
KBE Works	Vision KBE [97]	Specifically designed for integration with SolidWorks.
CATIA Knowledge Engineering/Ware	Dassault Systèmes	integrates knowledge management into the product design process

5.7.4. Patent Landscaping

The purpose of this patent landscaping is to add relevant information to the market analysis and scientific literature to have a complete overview of the diffusion on knowledge based systems at a global level.

The technical area investigated is the design automation, especially focusing on KBE methodologies and tools.

The search has been performed using the Orbit tool by Questel [98]. The term “knowledge based engineering” has been searched in the main three fields to avoid non relevant patents: title,

abstract, claims. The search returned 32 results. Data present in the search are not complete regarding the last 18 months due to the non-disclosure period for patents.

The two countries that take almost all the patent landscape and where the most patents have been granted are USA (19) and China (10). The first patent dates back to 1996, and it was granted to Ford Motor Technologies "Method for optimizing the design of a product using knowledge-based engineering techniques". After 1996, the diffusion of patents on the topic had peak from year 2000 until 2003. After that date, the concentration of patents in the area of KBE decreased to zero. During last year (2015) there was a peak of patents registrations all assigned to a Chinese company Chengdu Information Technology that has been highly involved in applying knowledge engineering techniques to big data collection.

The top assignees of the patents are Ford and United Technologies for the years before 2000. On the contrary, Chengdu and Siemens (provider of the software that was used for this study) have been more active in the field after 2010.

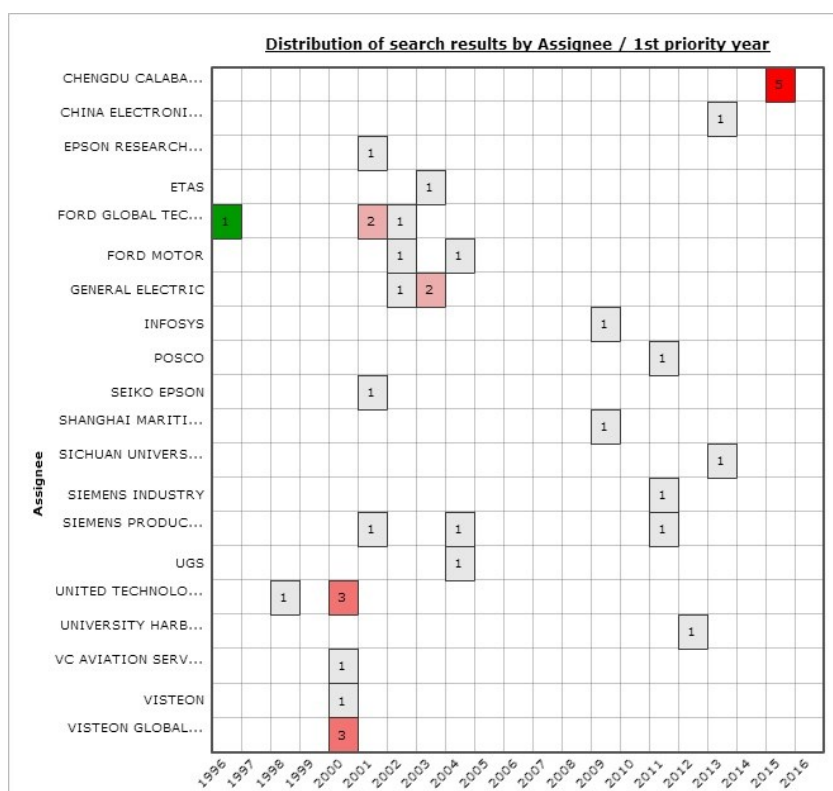

Figure 46: Distribution of patents by Assignee over time for the term "knowledge based engineering"

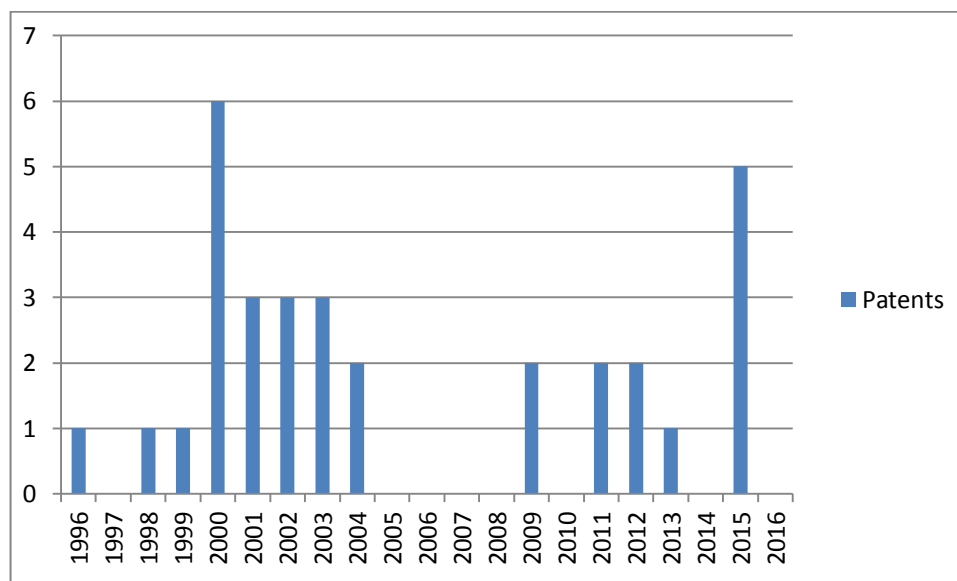

Figure 47: Distribution of patents number over time for the term "knowledge based engineering"

The same landscaping has been performed using "design automation" as a different keyword. This search returned 1057 patents as a result.

The first patent on the topic is assigned to IBM in 1972. IBM has been the sole player in the field for some years. After 1990 the patent landscape is highly dense (Figure 48) with an increasing trend shown in Figure 49. The top two assignees in this landscape are Synopsys with 107 patents and Cadence Design Systems with 80 registered patents.

The low number of patents returned by the "knowledge based engineering" query may be due to the fact that KBE is mostly intended as a methodology/algorithm, thus something that is less object of patents and IP protection. On the contrary, the high number of patents returned by the second search may be due to the fact that "design automation" is a fairly wide definition and covers a large range of patents, some of which are not related with automating repetitive design tasks.

The patent searches can be filtered for technology domain, but almost all patents in this topic are categorized as "Information Technology". Therefore it is not possible to verify all the domains of application both for the term "knowledge based engineering" and "design automation".

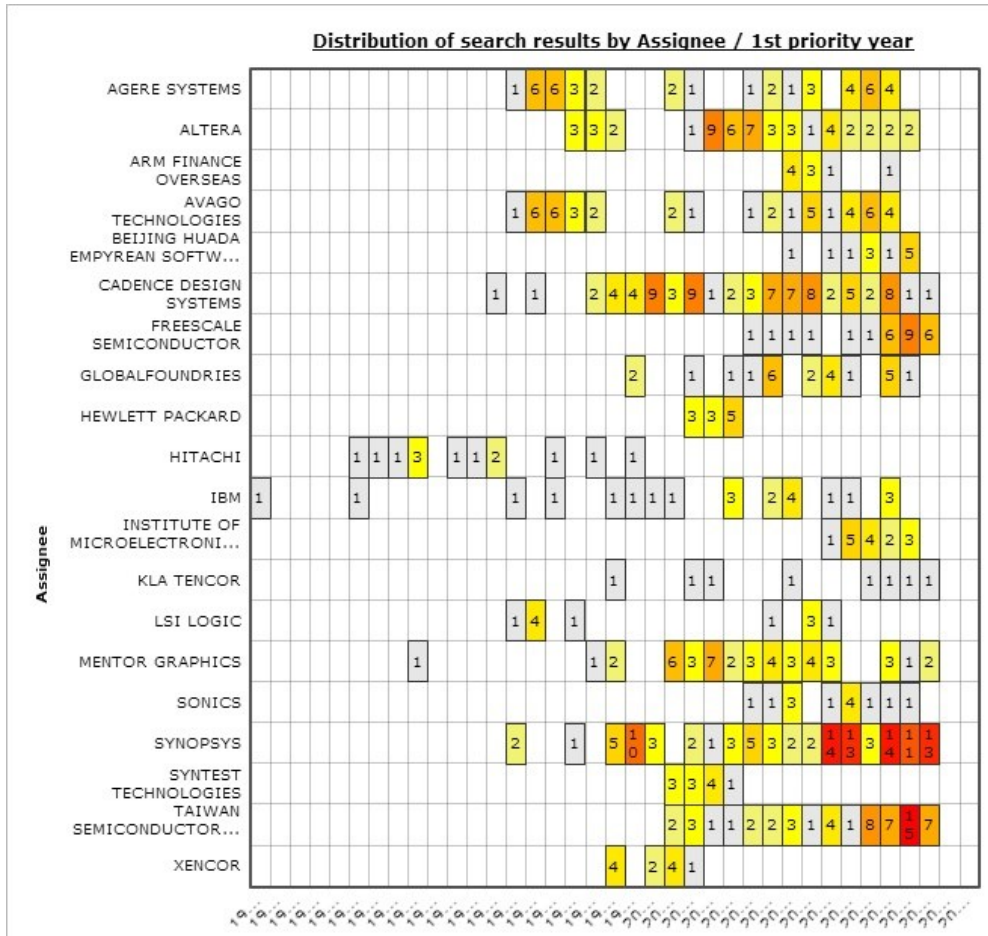

Figure 48: Distribution of patents by Assignee over time for the term "design automation".

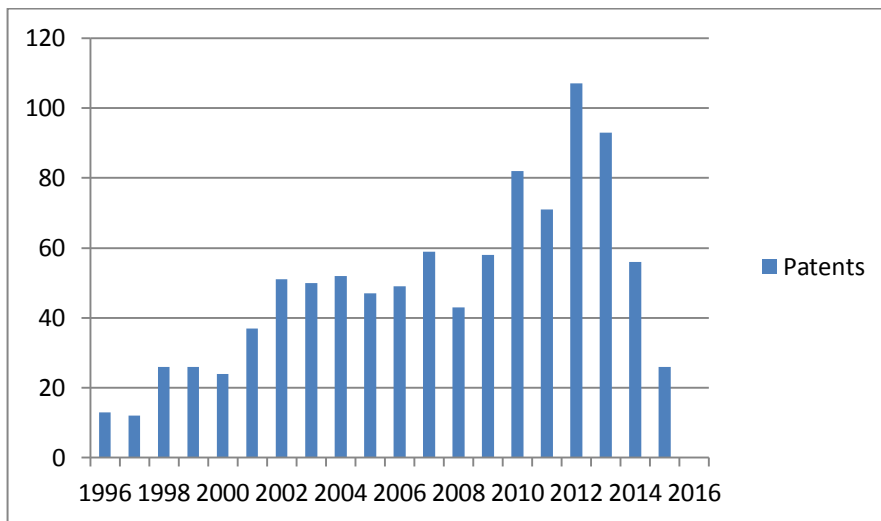

Figure 49: Distribution of patents number over time for the term "design automation"

5.7.5. Conclusions

The presented cost-benefit analysis is meant to help decision makers in setting strategic directions for the company. In this specific case, the shift to a KBE approach requires a radical change of processes, people involved and competencies. The specific KBE application, as shown, can be

developed using existing KBE software tools. However, the company has the possibility to develop from scratch a new KBE application. This would of course increase the effort in terms of hours and costs but it is part of a make or buy decision. The decision to make-vs.-buy has a rich and varied literature reflecting its importance and interest to both scholars and practitioners [79]. However, there is no standard and unique method to take this decisions and the variables that affect the choice change from time to time. Commercial off-the-shelf KBE tools appears to be not at a mature stage of development. Other tools that focuses more on supporting the sales configuration phase are more user friendly and commercially appealing. Nevertheless they may lack the possibility to be customized according to the requests of the company.

Given the current market conditions the adoption of KBE technology still seems not being a top priority for engineering companies and equipment providers. Some of the reasons that are impeding the diffusion of knowledge based approaches to the automation of design tasks have been highlighted in this chapter.

In conclusion, the presented study and the evaluation of benefits compared to cost is a tool available for the managers to take decisions supported by empirical evidence. However a final decision on the introduction of a KBE approach is not the scope of this research and is still an on-going evaluation that has to take into considerations further external variables.

6. Related work and Challenges

Abstract

The knowledge presented in this thesis is based on a series of assumptions and a well-defined industrial context. This chapter presents a discussion on the works related to the kernel of this thesis. Furthermore it gives an overview of the research challenges that will be tackled by the next steps of this study. In particular, among the presented topics, (I) the introduction of a tool to perform integrated 2D and 3D layout design will be discussed as an improvement of design performances during the proposal engineering phase. Regarding the next challenges, the attention will focus on four crucial topics: (II) discrete event simulations to be integrated into the KBE applications, (III) the implementation of new paradigms of powertrain assembly lines, (IV) a research project funded by the European Commission that aims at integrating many of these elements and (V) the investigation of ways to objectify the evaluation of design performances and evaluate improvements.

6.1. Integrated Proposal Tool

One of the most time-consuming activities related with the efficiency improvement during the proposal engineering phase has been the choice and implementation of a new software tool for fast 3D layout design. This activity, less *research intensive* is strongly related with the KBE application as it is based on the same concepts of modularity and fast system configuration that are the basis of this research study. The adoption of this new software tool for fast layout design can be considered as the first step of the path towards an automated design of PA lines.

As anticipated in 2.4, the proposal department for PA used to work defining the scope of supply starting from the RFQ, designing a 2D layout with AutoCAD® and linking all the equipment with the cost database and estimating tool). The costs database is currently managed with an excel file.

Therefore, the work of improving performances during the proposal engineering phase started with the introduction of a new software tool to enrich the technical proposal with a 3D representation of the line. The introduction of 3D layout is a crucial step towards the digital factory concept that enhances product, plant and process engineering to align a virtual model of the factory with the real shop floor. CAD tools for factory layout planning are available that provide predefined modules for creating detailed factory models. These layout tools allow to work with predefined objects that virtually represent the resources used in a factory. These predefined objects combined with the specific equipment of the system integrator (i.e. Comau machines) allow the creation of a 3D modular layout model in a fast and efficient way. Virtual reality models enable to move through factory mock-ups, walk through factories, inspect, and animate motion in a rendered 3D-factory model. This design and communication technology also provides design collaboration activities in order to view, measure, analyse, and inspect for clearance in a 3D-virtual factory model at an early stage of design improving also communication with the customers and non-technical people in general [99].

6.1.1. Methodology

The methodology for this activity did not comprise an analysis of the existing literature. As a matter of fact, the methodology followed a series of logical steps for the adoption of a new software tool: (i) first the requirements from designers and engineers where collected, then (ii) a benchmark analysis among commercial-off-the-shelf tools was conducted. Having chosen the new tool, a big effort was directed towards the (iii) definition and creation of the 3D components libraries. Finally, (iv) the new proposal procedure has been formalized and disseminated to other Comau facilities worldwide.

Software requirements

The aim of this task was to change the approach and make the 3D layout design a standard *de facto* in the proposal engineering department of Comau PA. Some specific requirements were collected directly from the people involved in preparing technical proposals. The question that was asked them was “*Consider a new software tool to design proposal layouts, which are the features that you would like the software to have?*”.

The requirements collected from the proposal designer and engineers can be grouped into three macro-categories listed below with some examples of requirements:

- *General Purpose:* User-friendly, low cost, fast learning curve;

- *CAD Capabilities*: Integration between 2D and 3D layout, creation of special parts, easy connection among parts, etc.;
- *Tool Compatibility and Integration*: Ability to import Solidworks (to create components libraries), export formats useful for simulation (e.g. JT files), automatic BOM creation, etc.

All the expressed requirements had a weight from 1 to 3 (*critical, important but not critical, non-critical but nice to have*). Not all the requirements are listed as this is not the main scope of this thesis. The overall goal of this chapter is to describe one step of the methodology used to introduce a new software tool for increasing proposal engineering performance.

Benchmark Analysis

The benchmark has been performed among existing and commercially available software tools, ready to be implemented in the day-to-day business. The main players in the field of virtual factory tools are three global software houses: Dassault Systèmes, Siemens and Autodesk. The decision, shared with the Comau ICT department, was to perform the benchmarking only among Siemens and Autodesk that propose two different tools that better suit the Comau needs.

The benchmark was conducted with the help of consultants both from Siemens and Autodesk that worked on the same case study of design of a typical plant with the use also of some Comau specific equipment. Each of the requirements received a score from 1 to 5 (*Not satisfied, weakly satisfied, neutral, satisfied, satisfied better than competitors*). At the end of the analysis, the suite provided by Autodesk called Factory Design Suite [100] scored the highest result and was selected as the most suitable solutions for the identified needs. As a matter of fact, the suite comprises a series of tools that are able to complete the technical proposal with different outputs as shown in Figure 50.

The software tools that compose the suite are mainly four: (i) *Process Analysis 360*, a tool to model the line flow and perform some preliminary analysis; (ii) *AutoCAD* for 2D layout design; (iii) *Inventor* for 3D layout design; (iv) *Navisworks* a tool for realistic representations of the virtual factory and for creating animations. However, the main feature of the Factory Design Suite that outperformed competitors is the seamless integration between 2D (AutoCAD) and 3D (Inventor) layout design.

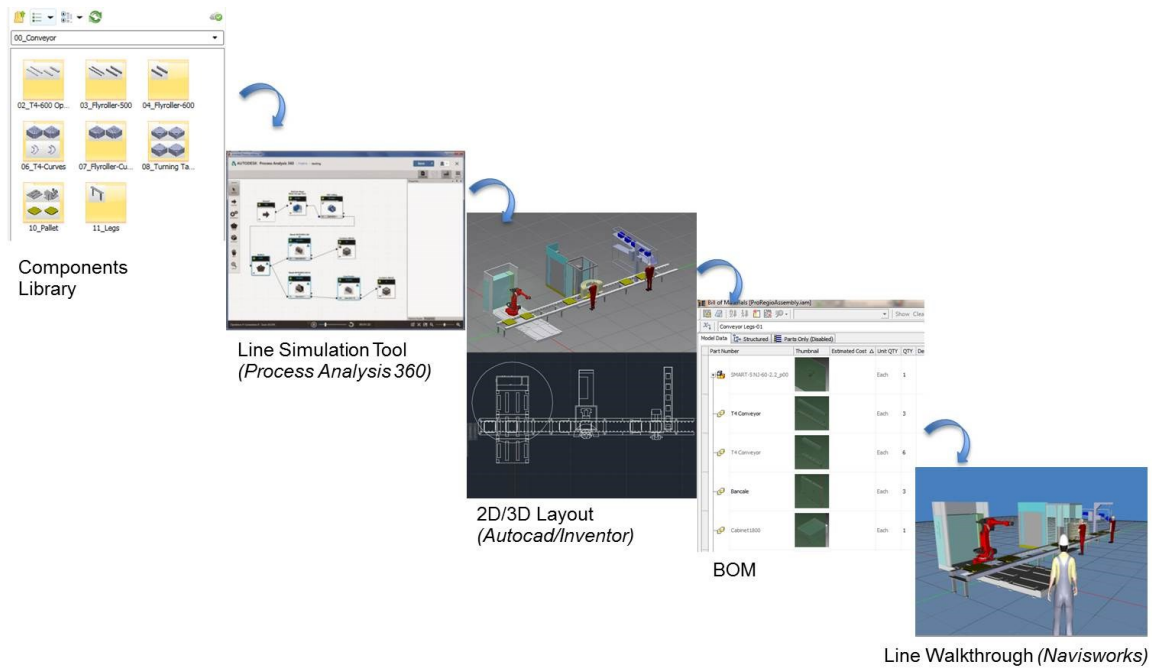

Figure 50: Overview of the tool comprised in Factory Design Suite 2016 by Autodesk

3D Library Development

As anticipated, the commercial tools for 3D plant layout design usually present an integrated library with 3D components with typical objects present in manufacturing plants. Nevertheless, specific engineering provider companies have to use their own technical solutions and components when configuring a manufacturing plant. Therefore there is the need to work for the creation of these libraries of simplified 3D components.

The more elements are present in the libraries and the faster will be the configuration of the 3D layout. However these elements have to be properly defined and modelled. The simplification of 3D CAD models is a time-consuming activity. There are some automatic procedures integrated in CAD tools usually based on volumes or feature recognition. However, often this tools fail to reach an adequate level of simplification. Thus the simplification is made by manually redesigning the component have as a model the final object.

Factory Design Suite library is managed in Inventor, which is the 3D CAD tool of the factory design platform. It works with “Assets” or rather 3D model with features and properties associated. The same assets have both a 3D and 2D representation. Therefore this feature allows the suite to automatically synchronize and switch from the 2D to the 3D version of the same layout. The defined libraries have a set of standard Comau components as well as a dedicated section for regionally customized products and machines design for specific projects. Nevertheless, these project-specific components can be re-used in other proposal designs.

Implementation and Dissemination

After the selection of the new tool, the first training courses and the creation of the 3D components library, the new proposal flow has been defined and rolled out to all Comau facilities worldwide. This

phase included the definition of guidelines for the use of tools and the decision on how to manage and update the central 3D libraries (same for all Comau facilities).

The whole activity (i.e. from the benchmark to the first proposal 3D layout) took around 6 months. The system is currently in place and used by different designers in different regions of the world (i.e. Italy, China and US). All the designers that use the software now can base their designs on the same standard components stored in the centralized libraries. Figure 51 shows the example of a 3D layout designed with Factory Design Suite.

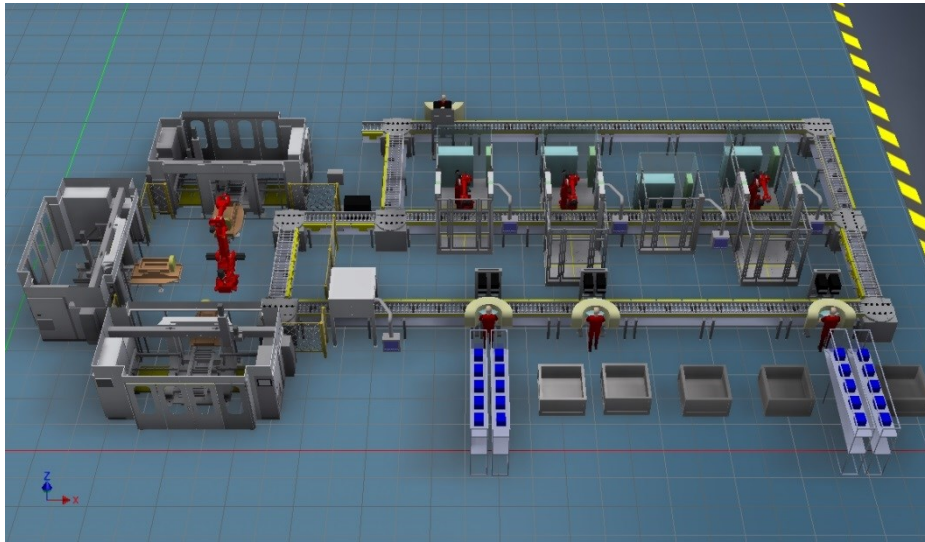

Figure 51: Example of a 3D Layout of a Powertrain Assembly Line (Comau USA).

6.1.2. Integration with KBE Approach

As it was mentioned at the beginning of this sub-chapter, this activity can be considered as a first step towards the automation of the layout design. The layout design process will greatly benefit from the introduction of this new software tool able to speed-up the design process. However the configuration of the layout is still a matter of knowledge and experience of the design engineer. The designer in fact uses his/her past experience and competences to choose the right elements of the library and combine them to achieve the final layout shape.

The KBE approach will be the next step to further improve design efficiency during proposal. The competence of the design engineer, stored in a KBE application in the form of rules, will automate the construction of the layout CAD model.

The KBE application is currently integrated with Siemens NX for the 3D layout generation. The choice was driven by the fact that the integration of NX with Rulestream was already developed and available. In the future, an integration with Autodesk Factory Design Suite will be developed. This will ensure a better synchronization between 2D and 3D layout as well as allowing different outputs (e.g. rendering, walkthrough, etc.). Nevertheless, the best configuration of the KBE application is to be able to provide different outputs, allowing the user to choose which software tool to open for the generation of the output documents. Therefore the KBE application in the future will need to be able, using the same simplified blocks, to generate a CAD independent output.

6.1.3. Conclusions and Next Steps

In conclusion, the introduction of a new software tool for a more integrated technical proposal is only an intermediate step on the roadmap for improvements of performances during the proposal engineering phase. Table 11 summarizes the main differences in terms of outputs of the proposal engineering phase among these different development phases: from the *as-is* phase to a fully implemented KBE application, passing through the already implemented tool for 3D proposal design.

As anticipated, among the next steps for this activity there is the need to integrate the new software tool for the proposal department within the KBE application. What is currently missing is the possibility to have metadata generated by Rulestream and able to communicate with different CAD systems (i.e. not only the ones already integrated in the tool) and generate 3D layouts in the relative file format. This can be done by writing the appropriate APIs to formalize the interaction between the different tools.

Table 11: Differences between outputs in the different proposal flows scenario.

Tools	OLD Approach		AS IS – Integrated 2D/3D Tool (Factory Design Suite)		TO BE – Automated Design (KBE Application – Rulestream)	
	✓	Manual	✓	Manual	✓	Automated
2D Line Layout	✓	Manual	✓	Manual	✓	Automated
3D Line Layout	x	-	✓	Automatically generated from 2D	✓	Automated
Line Walkthrough	x	-	✓	Automatically generated model from 2D (video is created manually)	x	To be defined
Scope of Supply	✓	Manual	✓	Partially Automated – the system generates a BOM	✓	Automated
Cost Estimation	✓	Manual	✓	Automated - can be linked with cost database	✓	Automated – can be linked with cost database
Discrete Event Simulation	x	-	x	-	✓	Automated
Layout Optimization	✓	Manual	✓	Manual	✓	Automated

6.2. Discrete Event Simulation (DES)

The VDI (Verein Deutscher Ingenieure, Association of German Engineers) guideline 3633 defines simulation as the emulation of a system, including its dynamic processes, in a model one can experiment with. The simulation aims at achieving results that can be transferred to a real world installation. In addition, simulation defines the preparation, execution and evaluation of carefully directed experiments within a simulation model.

In particular, a discrete, event-controlled simulation (DES) only takes points in time (events) into consideration that are of importance to the further course of the simulation. Such events may, for example, be a part entering a station or leaving it or moving on to another machine. Any movements in between are of little interest to the simulation as such. It is only important that the entrance and the exit (out) events are displayed correctly.

DES is successfully applied to manufacturing processes in several industries for its evident benefits in terms of increasing productivity by optimizing the line flow. In general, simulation can be considered as a practical methodology for understanding the high-level dynamics of a complex manufacturing system [75]. According to Yücesan and Fowler [101], simulation has several strengths, including the following:

- *Time compression*—the potential to simulate years of real system operation in a much shorter time.
- *Component integration*—the ability to integrate complex system components to study their interactions.
- *Risk avoidance*—hypothetical or potentially dangerous systems can be studied without the financial or physical risks that may be involved in building and studying a real system.
- *Physical scaling*—the ability to study much larger or smaller versions of a system.
- *Repeatability*—the ability to study different systems in identical environments or the same system in different environments.
- *Control*—everything in a simulated environment can be precisely monitored and exactly controlled.

Figure 52 shows the example of simulation model of a powertrain assembly line. The model is built following an existing physical layout of the line. The correlation between the layout and the simulation model is crucial for being as much as possible close to the reality so that the results obtained in the virtual environment are reflected in the shop floor.

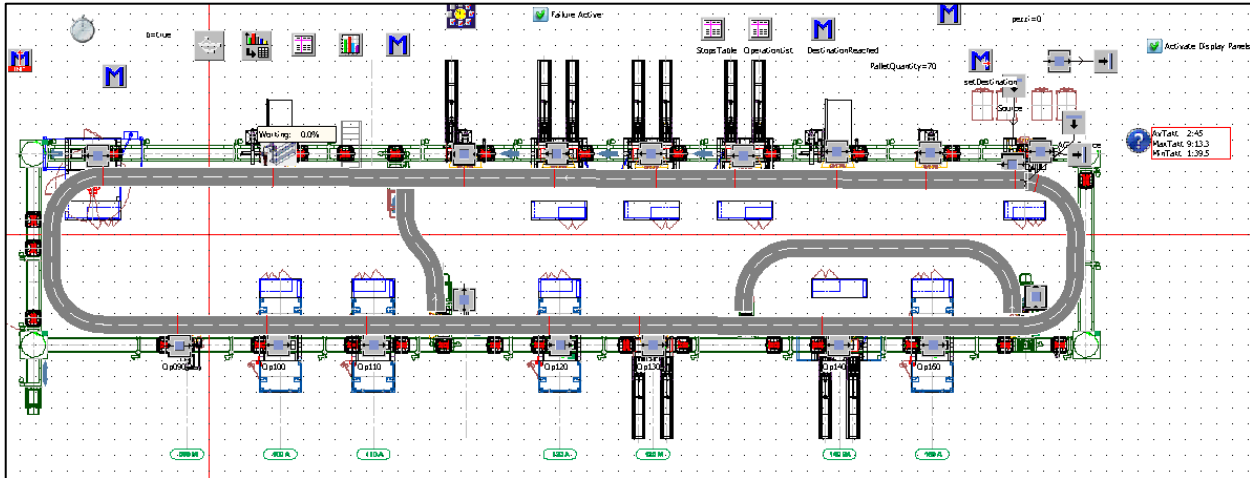

Figure 52: Example of a DES Model

6.2.1. Methodology

The activity presented here is currently going through the first steps of investigation. The current phase includes the analysis of a suitable software to be integrated with the KBE application and the investigation of technologies for the automatic generation of simulation models. Similarly to CAD systems, there are several competing tools on the market that provide comparable simulation features. Among the most used, there are Plant Simulation (by Siemens), Automod, Arena and Flexsim. Plant Simulation is a tool developed and sold by Siemens, likewise Rulestream. However, Rulestream, despite providing some in-built integration with CAD software tools such as Siemens NX and other competitors (i.e. section 5.4.3), does not provide integration with Siemens Plant Simulation. This is probably due to the fact that KBE and Engineering-To-Order technologies are mainly applied to product configuration where discrete event simulations have no application. On the contrary, DES is a critical element in production line design. Therefore, the introduction of DES into the knowledge based configurator would represent a new need especially targeted to manufacturing systems design.

The integration of commercially available DES tools into the KBE application requires developed programming skills and will most likely take some time to be defined. Nevertheless there are some promising opportunities from the use of open source simulation software such as Jaamsim [102]. This kind of tool appears to be more accessible in terms of APIs and could reduce the time required for the integration. Once the integration of the simulation tool will be developed, the simulation will be run and its outputs validated against a manually designed model.

6.2.2. DES in the KBE Application

DES plays a vital role during the proposal engineering phase. Simulating the system can help in identifying problems at an early stage of the line design.

However, DES is not always a customer request. As a matter of fact not all customers require the line to be simulated during the proposal phase. However, most of the OEMs have some sort of simulation of their plants all over the world to manage productions and orders allocation. The diffusion of simulation techniques among automotive producers is constantly growing. Therefore the

simulation is an essential added value provided by the system integrator company to their clients at some point in time.

By anticipating the simulation during the proposal phase the benefit is two-fold: (I) external as the customer is able to see the simulation of the system before the beginning of the project and (II) internal as the provider of the line is able to verify possible bottlenecks and offer an optimized system supported by a virtual simulation, anticipating an analysis that will be performed if the project starts.

The integration of DES into the KBE application will allow the line builder (i.e. Comau) to provide a detailed analysis without increasing the proposal time and having more resources. In some aspects the benefits deriving from an early simulation of the system are comparable to the benefits achieved with a 3D design of the layout.

In the literature the capability of generating simulation models in an automatic (or semi-automatic) way is considered one of the greatest challenges in the simulation of manufacturing systems. The automatic generation of a simulation model answers to the need of speeding up the overall time required to build a simulation model [103]. However, most of the papers addressing this issue in the literature have noted as the main drawback of these automation approaches, the limited level of automatism that can be actually reached.

As anticipated, in the literature there are several approaches for the automatic generation of a simulation model the main ones being [104]:

- Parametric approaches: Models are generated based on existing simulation building blocks stored in simulation libraries, which are selected and configured based on parameters.
- Structural approaches: model generation is based on data describing the structure of a system, typically in the form of factory layout data from relevant CAD-systems.
- Hybrid-knowledge-based approaches: These approaches combine artificial intelligence methods (expert systems, neuronal nets) with both of the above approaches.

In such approaches of automatic (or semi-automatic) model generation a simulation model is not created manually using the modelling tools of the chosen simulator, rather it is generated from external data sources using interfaces of the simulator and algorithms for creating the model. This is often also referred to as “data-driven model generation”. The promise of such approaches is that they, if successful, can reduce the amount of time needed to create a simulation model as well as the expertise needed for creating and conducting simulations[104].

6.2.3. Conclusions and Next Steps

This work is presented as an ongoing activity as currently there are not enough results regarding the possible integration of DES into the configurator application. An interesting experience concerning the use of DES for the simulation of layout alternatives is however presented in section 6.4.3. However, it is considered a primary goal the construction of a discrete event model directly as an output of the KBE application.

6.3.ProRegio

Some of the requirements of this research to improve efficiency in the proposal engineering phase have been included in a proposal for a European funded research project. This proposal was accepted and is now a wider and running research project that receives funding from the European Union's Horizon 2020 research and innovation program under grant agreement no. 636966. The project is called *ProRegio* – short name for the long project title “*Customer-driven design of product-services and production networks to adapt to regional market requirements*”[105]. The main aim of the project is to create a product-service development platform able to increase the competitiveness of European companies in a global marketplace by including varying customer requirements and satisfying regional needs.

The project has kicked off in January 2015 and will run for 36 months. It is developed by a consortium of various partners, including prestigious European Universities, SMEs (Small and Medium size Enterprises) and big industrial partners active in several markets, not only in the automotive field.

6.3.1. Methodology

The *ProRegio* project has a very wide scope: it ranges from product design to production network to plant design with applications in different industrial sectors including automotive (Comau), aerospace and white goods. One specific aspect of this research project is the design of production systems according to changing regional requirements. This matter is tackled by Work Package 4 (WP4) “Process and plant design for product-service innovation” whose main partners are Comau, Politecnico di Milano and EnginSoft.

The goal of WP4 is to develop a sort of production line configurator that, based on some inputs data that the user (proposal or customer) insert in the system, automatically generates a draft layout of the process and optimizes the layout in the most efficient way linking the different tools involved. The overall architecture of WP4 is shown in Figure 53. The design of the production line (e.g. drag and drop of existing library components) should be substituted by an automated system that based on some configuration rules is able to generate a first layout draft. This layout configuration can be then evaluated by other tools (provided by EnginSoft) in terms of optimization and performance assessment. Finally the optimized and simulated layout will be shown in a 3D CAD environment. The entire architecture is substantiated by a common data framework that will enable data exchange between the different pieces of software of the platform. Each module of the application is related to a specific task part of WP4.

Related work and Challenges - ProRegio

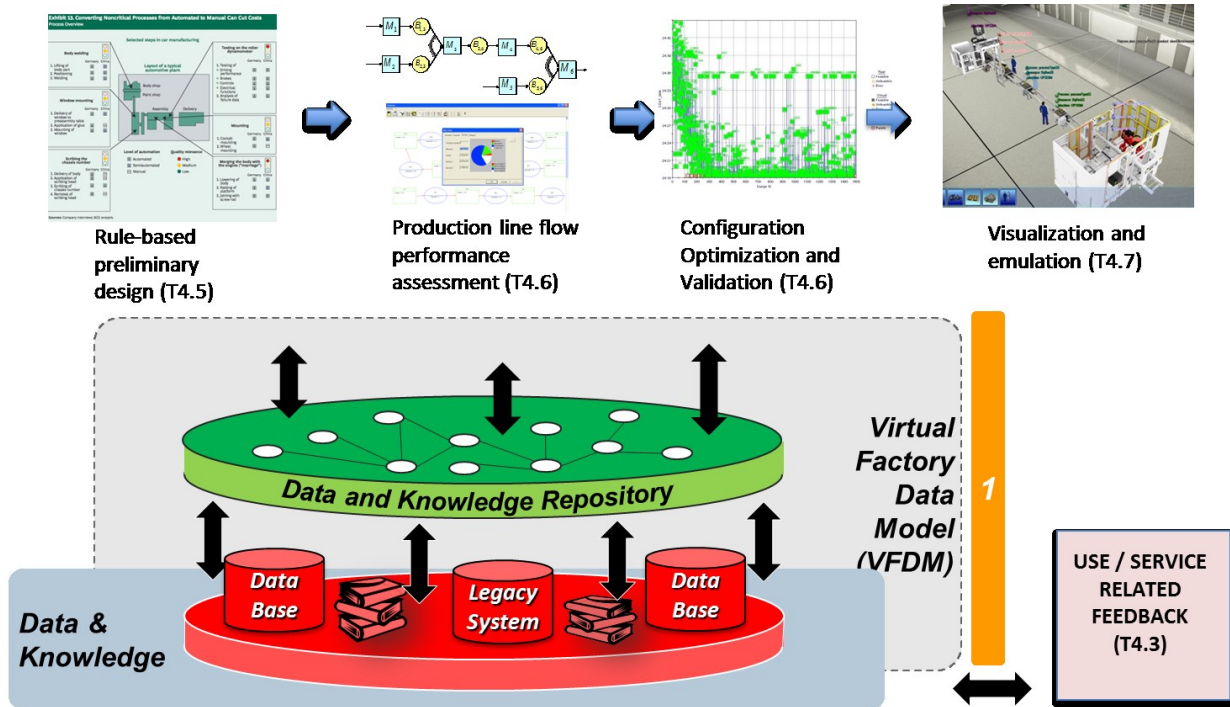

Figure 53: Overall architecture of ProRegio WP4 for process and plant design.

The desired software tool should be able to help engineers/designers in finding the best production line solution by integrating software tools for optimization, simulation and visualization with Comau standard machines and regional/customer rules. This tool will help to translate customer requirements into concrete outputs (e.g. exportable to different commercial design tools format) in a time and cost effective way.

In this project both Comau Body Assembly and Powertrain Assembly are involved. The collaboration between the two Business Units is important to collect the different requirements according to the different processes developed. At high level the methodology for the Comau use case is divided into two macro phases: first the development of the line configurator based on a Comau case study that will then be implemented in the bigger picture of the project which foresees a bigger software platform that includes product and production network design modules.

However at a local level, the Comau use case follows the roadmap shown in Figure 54. The case study is divided into two main sections: the *conceptual layer* which includes the definition of the logical layout of the line based on processes and rules and the *physical layer* where the logical layout is translated into a tangible output.

The research project is currently at an early stage of development. Some requirements and line configuration rules have been collected within Comau and they will be integrated into a software tool with the help of Politecnico di Milano and EnginSoft. The future developments of this research projects, however, will be very important for the topic of this thesis.

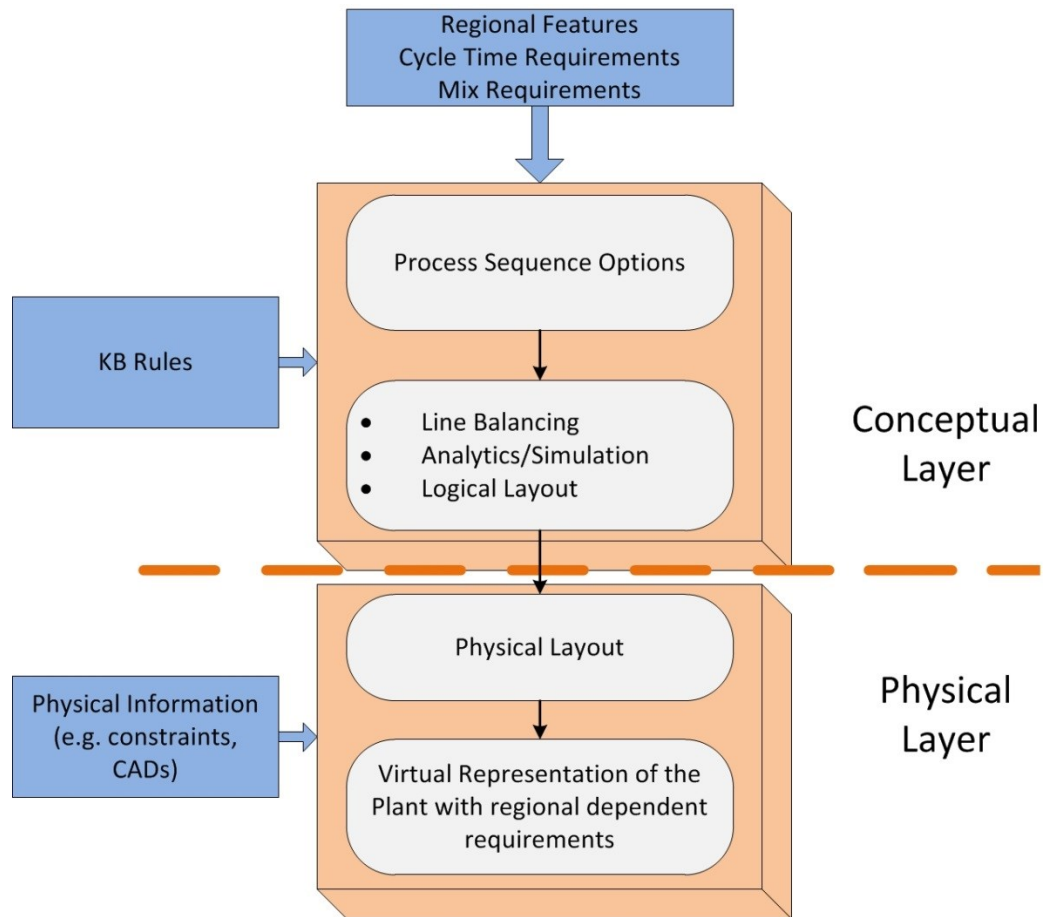

Figure 54: Logical flow for Comau Use Case inside ProRegio

6.3.2. ProRegio and the KBE application

The ProRegio project and the research study described in this thesis are similar in several aspects. The two research projects share part of the approach and some of the outputs. The ProRegio project and the KBE application are strongly related. In particular, ProRegio and especially the work carried out in WP4 can be seen as an extension of the main work presented in this thesis on two different axis: (i) improvement of the KBE configurator with the inclusion of an optimization and line flow simulation module, and (ii) integration within the KBE configurator of regionalization features of manufacturing systems.

The project builds upon the achievements described within this thesis and aims at implementing them with further research developments. It is interesting to compare the methodology presented in Figure 53 and the software modularity of the KBE application shown in Figure 26. The output of the ProRegio project are complementary to the research study here described and will be integrated in the application when mature.

6.3.3. Preliminary Scientific Results

As of today (March 2016), WP4 is under development and the main analysis at this point regards ways to integrate the configuration optimization software into the KBE architecture. The optimization software developed by Politecnico di Milano and EnginSoft has been tailored to the

Comau use case. The tool is able to automatically configure and run a mode FRONTIER performance evaluation and optimization workflow providing multi-objective optimization, generation of optimized candidate solutions (Pareto frontier), robustness and sensitivity analysis on Pareto solutions and finally a DES on the found Pareto solutions. The systems takes in input reliability and cycle time parameters and runs in an iterative fashion the calculation of the optimal solutions and the evaluation of their performances (Figure 55). Finally a robustness analysis and a simulation can be run on the optimal solutions in output.

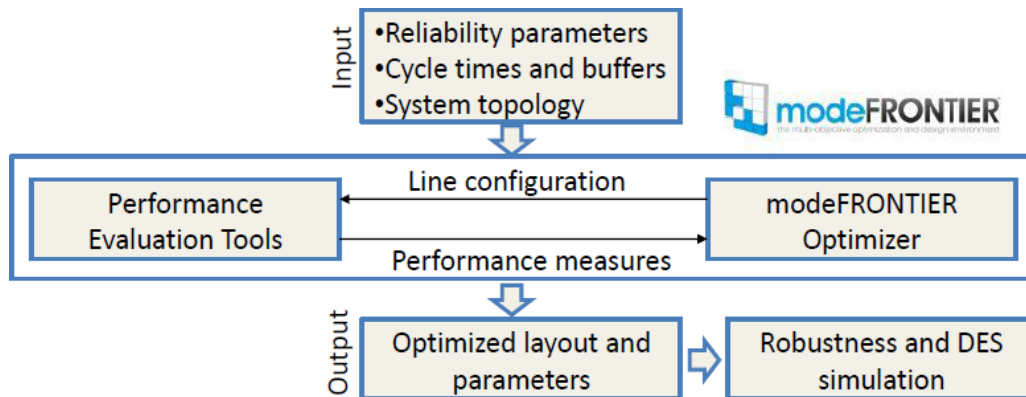

Figure 55: Overall architecture for the optimization tool tailored to Comau use case (part of the conceptual layer).

In addition to the optimization tool, the first results have been collected in the area of regionalization requirements of the system. The question that was asked to the project members was: “*what are the regional features that differentiate production systems around the world?*”. After an analysis it was found that there are 4 main axis for regional customization of manufacturing systems:

- *Comau Standard Components:* standard components are intrinsically the same all around the world. Nevertheless depending on where the plant is going to be installed there are different manufacturing strategies for standard components. For instance robots to be implemented in a Chinese plant are manufactured directly in china whereas robots for European or North American market will be produced in Italy.
- *Supplier Components:* Comau is both a provider of technical solutions and a system integrator. As a matter of fact, assembly line are composed of standard components and equipment both from suppliers. These components are for example motors, slides, actuators and so on. These items vary according to the country where the plant is going to be installed (i.e. different suppliers all over the world, different electrical equipment, etc.).
- *Line Configuration:* the high level configuration of the manufacturing line can be influenced by the region where is going to be installed. One of the variable that may be subject to regional variations is the level of automation of the line, which can be influenced by external factors such as labour cost, norms and regulations and technical skills availability.
- *Documentation:* it is straightforward to imagine that depending on where the line is going to be built, the documentation needs to be aligned with different languages. The same problem may present with technical documentation and measurement units (e.g. metrical or imperial standard units).

6.3.4. Conclusions and Next Steps

The described research project is an important opportunity to work on a research intensive project exploiting public funding. The actors gathered together are the same that have been working on the research project described within this thesis (i.e. Comau and Politecnico di Milano). In addition, the competences and skills of EnginSoft for optimization algorithm could boost and complete the KBE configurator. Furthermore, from an industrial standpoint, the opportunity to complete the line configurator with the missing elements represents a great advantage on two aspects: first it helps supporting research activities that may have a long time from application in a real industrial environment and on the other hand it helps completing the prototype of the application that can be presented to the management to receive additional funding for bringing everything to implementation. As a matter of fact, the *ProRegio* project is classified at a European level as bringing the technology readiness level from 3 (beginning of project - experimental proof of concept) to 4 (end of project - technology validated in lab)[106].

6.4. Automate Guided Vehicles Conveyor System

Standard Products and Solutions are constantly evolving over time at the pace of changing market requirements. The aim of the Standard and R&D department is not only to develop standard solutions based on a modular approach (see section 2.3), but also to investigate new market opportunities and develop innovative solutions. One of the most recent development of the market of PA lines is the use of automated guided vehicles (AGVs) both for replacing traditional conveyor and logistics systems inside production plants. Despite being an already existing and widespread technology, AGVs have been a trending topic in the last years due to the increased level of flexibility required and the interest in their use is still expected to grow in the manufacturing sector. AGVs introduce a new paradigm of product movement and logistics inside the plant. AGVs are able to autonomously perform a set of movements: they can follow predetermined paths, or real-time decide the path according to the current condition of the surrounding environments. They are also provided with a set of sensors to detect the presence of objects along the path, in order to avoid collisions. The advantages that such systems can offer include increased flexibility, better space utilization, improved factory floor safety, reduction in overall operating cost, and easier interface with other automated systems. For a general review on AGV literature, the reader is referred to [107] and [108].

As seen, powertrain assembly lines are traditionally made up of stations placed in a serial layout, and items move through consecutive workstations by conveyors. This solution is considered efficient for mass production but it allows a very low flexibility. The modularity of systems described in 2.3.2 is a methodology to reduce the low flexibility of high volume assembly lines. Usually, when more than one model has to be assembled on the same line it is better to consider possible future expansions of the line during the design phase of the initial line. Otherwise, changes for increased or mixed production may be very difficult to be implemented if not foreseen from the beginning.

The research question asked for this work could be formulated as *“How can the introduction of AGVs modify the paradigm of powertrain assembly lines?”*

Flexible manufacturing systems (FMSs) are a viable answer to meet the market demand for increased product variety, short product life cycles, and uncertain demand. Despite their great diffusion at an industrial level the concept of FMS is not widespread in powertrain assembly lines. Here we propose the development of a cellular layout for more flexible assembly systems and logistics. From a strategic perspective, an efficient layout design is critical for the implementation of a manufacturing system. The layout is difficult to design, costly to modify, and significantly affects the efficiency of the entire system. It has been estimated that 20%-50% of the total operating expenses within manufacturing operations are attributed to material handling, and it has been reported that effective layout design can reduce these costs by at least 10%-30% [109]. In addition to material handling costs, the facility layout also impacts the production costs and the work-in-process inventory levels [110].

Part of this work has been conducted thanks to the collaboration with Politecnico di Torino, department of Management and Production Engineering. In particular, they provided the algorithm for the new layout design and competence in line simulation.

6.4.1. Methodology

There is a wide literature targeting AGVs system, FMSs and cellular layout. Nevertheless there are virtually no papers that target the comparison between traditional conveyor systems and AGVs fleet. Before applying AGVs in assembly lines to substitute traditional conveyors a robust feasibility analysis needs to be performed. Traditional conveyor system are well-established automation standards and are hardly replaceable. Nevertheless, the mere replacement of traditional conveyors with AGVs, keeping the serial layout for the workstations, is not economically convenient and does not allow to fully benefit from the advantages that can result from the deployment of autonomous vehicles with reduced path constraints.

The methodology for this work consisted of three main steps:

- (I) *Analyze* the *as-is* situation: model and simulate the throughput of a line with a traditional conveyor system. Estimate the minimum number of pallets for achieving the desired throughput.
- (II) *Replace* the traditional conveyor with a transport system based on AGVs. Each AGV is assigned to a pallet and a product. The positions of the workstation are kept the same. The AGVs move from one station to another in the same serial layout. They stop into the station, wait for the operation to be finished and go to the next one.
- (III) *Modify* the existing serial layout with a cellular layout to better exploit the advantages of using AGVs instead of the traditional conveyor system.

The case study chosen for this analysis is a slightly varied cylinder head assembly process. With respect to the assembly process described in the KBE application, this case study includes as well as the valve train components also the insertion of the camshaft which is usually postponed to the main engine assembly line. This process is quite simple to analyze, yet presents a higher number and variety of assembly tasks. Therefore this case study allows a good overview of the distribution of workstations for operation type in a cellular layout.

The described analysis is primarily focused on a high level view of the assembly system. This analysis neglects most of the technological constraints for the implementation of AGVs in powertrain assembly lines. The neglected constraints are for instance the entrance of the AGV into the workstation and the correct positioning of the workpiece for tasks where high precision is required (i.e. insertion). Nevertheless, we considered the real dimensions of the workstation and a minimum buffer area (i.e. distance between workstations) to allow the AGVs to enter and exit the workstations without collisions.

For the sake of simplicity, we made the hypothesis of a traditional line is composed of 19 workstations carrying out all the operation listed in Table 12. The cycle time of the line is 45 seconds and the layout shape is a simple closed loop. The used conveyor is a T4 friction roller conveyor, with nominal speed 1 m/s. The changes of direction of the pallets are achieved using rotating tables integrated in the conveyor system. The minimum number of pallets needed for achieving the desired efficiency (i.e. 98%) is 20. The same model is used to replace the traditional conveyor system with AGVs. The logic of the new AGV conveyor is the same as the traditional one. AGV move in sync with the engine along a track that follows the shape of the previous conveyor system. The maximum

speed of the AGV in the model is 1,5 m/s with an acceleration of 0,4 m/s². By keeping the same positioning of the workstations, there are not notable changes in the level of efficiency of the line. Nonetheless, this solution would result in a higher economic effort in settling the line, and would allow to exploit a few quantity of the advantages provided by AGVs.

Table 12: Bill of Process for the cylinder head assembly including camshafts.

ID	Cluster	Description	Avg process time (s)	Avg setup time
1	Load	Load and identify cylinder head to pallet	10	8
2	Sealant and lubrication	Lubricate valve guide bores or valves	15	8
3	Insertion	Install intake and exhaust valves	25	4
4	Leak test	Valve blow-by leak test	25	8
5	Rollover	Rollover 180°	10	8
6	Load	Load camshafts to pallet	15	8
7	Load	Load camshaft caps and bolts to pallet	20	8
8	Insertion	Assemble valve stem seal	25	4
9	Press	Press valve stem seals	15	8
10	Insertion	Assemble valve springs, valve spring retainer	25	4
11	Press	Key-up	15	8
12	Sealant and lubrication	Apply sealant	25	4
13	Load	Assemble camshafts, camshaft caps, bolts and pre-torque	10	4
14	Tightening	Torque camshaft cap bolts	20	8
15	Measure	Torque to turn	25	8
16	Press	Press camshaft seal ring	15	8
17	Tightening	Torque, intake, exhaust and/or injector studs	25	8
18	Marking	Cylinder head label	15	8
19	Load	Unload cylinder head assembly	10	8

6.4.2. Alternative Layout

The development of a new layout of the workstations is crucial for the exploitation of AGVs. However how to design the new layout is not a trivial task and depends on the operations that have to be performed. This design problem known in FMS literature as Facility Layout Problem (FLP) usually consists of three distinct stages: (i) selection and grouping of production and material handling equipment into cells, (ii) allocation of the machine cells to areas within the shop-floor (facility layout), and (iii) detailed layout of the machines within each cell (machine layout) [111]. This work addresses the layout problem (FLP) by assuming that the composition of each cell is known.

The idea is to create a cellular layout based on *process areas*. For the engine assembly, this process areas represent all the ten process clusters described in 2.3.1. Therefore we should have one area for each cluster. Each area is equipped with a sort of *hypermachine*, able to perform all the tasks related to a cluster, provided a defined set-up time. Thus, the machine in the process area *insertion* will be able to perform both install bearing and pistons assembly. Nevertheless the concept of

hypermachine is a great simplification and there are technological constraints that are not taken into consideration. If the same product has to perform more operations of the same clusters, it will pass several times through the same process area during the entire assembly process. Each process area has one machine by default. If there are more operations of the same cluster the number of machines in the process area can be increased by placing parallel machines. Therefore, when the AGV carrying the workpiece arrives in the process area, enters in the first station empty available in the area.

The crucial aspect of creating a cellular layout is the identification of the optimal positions of this process areas to optimize the outputs of production. The distribution of the stations along a serial layout is a task that is usually performed manually based on the designer's experience. Nevertheless some constraints are taken into account: spatial constraints of the plants (e.g. columns), center to center distances between station and technical constraints related to the sequencing of operations. On the contrary, the activity of positioning process areas in a cellular layout cannot be based on manual estimations but needs a more precise analysis for taking into account the many variables that can influence the optimization of the shop floor. Therefore, for defining the optimal positions of the process areas an algorithm has been developed based on the parallelism with a mechanical system. Suppose to have a set of bodies, connected with each other through springs; each spring has given stiffness and equilibrium length. The equilibrium configuration of this system is the one with the lowest residual energy. Similarly, the areas composing the manufacturing line can be considered as connected through springs, whose stiffness is proportional to the number of travels performed through each couple of cells. In this way, each cell is considered as an agent, able to interact with other agents, whose position is due to a balance of forces.

The morphology of the cells is not explicitly introduced: in the model, agents are described as circular objects: this simplification allows to deal with only one direction (the radius) rather than two (x and y length). Each cell is given two characteristic radii: R_{in} , which is the radius of the area occupied by the workstation; R_{out} , which depicts the area necessary to move around the workstation (for example, to permit AGVs transit or to supply components to the workstation). In Figure 56, an example of the interacting forces is shown. Two kinds of forces act between the cells i and j : the attraction force tends to lead the length of the spring equal to the equilibrium length; the repulsion force avoids overlapping between adjacent stations.

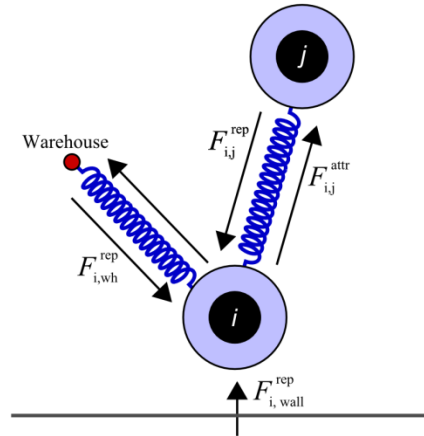

Figure 56: Interaction mechanism between cells (process areas).

The stiffness of the spring is equal to the number of travels performed through the stations i and j to produce one unit. Hence, the highest is the number of travels, the highest is K , the lowest is the distance between the two cells. In Figure 56, the black area is the circle with radius R_{in} ; the lilac area is the circle with radius R_{out} .

The warehouse is modeled as a punctual entity; it is described as an additional cell interacting with the other agents in the model according to the relationships above. Furthermore, repulsion forces are added to avoid cells going outside the plant area. A balance of forces is performed for each of the N agents in the model: the equilibrium configuration is the one for which $\sum F = 0$. Nevertheless, such balance provides the distances among cells, but not their position into the shop-floor. Hence, an artificial movement due to drag forces is introduced.

This algorithm has been tested to design in a cellular layout a line able to perform the bill of operations presented in Table 13. The column "cluster" has been used to group similar operations. The only exception is given by the Load cluster: the first and the last operations must be performed close to the warehouse, due to the weight of the part to be loaded; conversely, in operations 6, 7, and 13 lighter parts are managed. Further, since load operations are spread along the sequence, a unique cell placed close to the warehouse would generate a huge quantity of traffic and crossings between vehicles. For this reason, two Load cells are considered. In total, 10 working cells have been identified.

The number of machines composing each cell has been evaluated, keeping the overall utilization of the workstation. The results of this analysis are synthesized in Table 11: the 10 cells consist in one or two machines. In the traditional layout, 19 machines are necessary to perform the whole sequence. The first result of the layout reorganization is a reduction of this number: 15 machines are sufficient to keep the process stable. Given this clusterization, a square matrix K with the ten process areas as rows and columns contains the number of travels between each couple of cells. The direction of the travel is not taken into account: the scope of this step is to identify the movement aisles and the intensity of the traffic.

Table 13: List of process areas with machine optimization.

Area ID	Cluster	Operations	Avg. process setup time (s)	Inlet flows	Nr. Of machines	Capacity
1	Load A	1; 19	18.00	2	1	0.80
2	Sealant and Lubrication	2; 12	26.00	2	2	0.58
3	Insertion	3; 8; 10	29.00	3	2	0.97
4	Leak test	4	33.00	1	1	0.73
5	Rollover	5	18.00	1	1	0.40
6	Load B	6; 7; 13	21.67	3	2	0.72
7	Press	9; 11; 16	23.00	3	2	0.77
8	Tightening	14; 17	30.50	2	2	0.68
9	Measure	15	33.00	1	1	0.73
10	Marking	18	23.00	1	1	0.51

Then, the dimension of each process area must be evaluated. For the sake of simplicity, the hypermachines are considered as standard Comau automatic stations Smart Rob 1800 (i.e. section 2.3.2). Each machine has length equal to 4000mm and width equal to 1800mm. The distance between machines in the same workstation is 2200mm. Hence, the radii of the area occupied by the machines are equal to 2700mm for single-machine cells and 3800mm for double machine cells. The annulus surrounding the cell to support the movement of vehicles is 5000mm thick. The plant is supposed to be square; the length of the edge is 100m. The coordinates of the point representing the warehouse are (0, 0): this point is not moved during the optimization of the layout; conversely, all the working cells can be freely placed in the available area, without further constraints. The initial position of the agents is evaluated adding cells one-by-one in the area. First, the cell with the highest number of interactions with the warehouse is introduced (in this case, cell number 1). Then, the cell with the highest number of interactions with the agents already placed in the area is introduced in an iterative way. Finally, the model can be run to achieve the equilibrium configuration. The equilibrium configuration for the bill of processes used as case study is shown in Figure 57. Black circles represent the area occupied by the machines; lilac circles depict the working area. The blue lines represent the traffic directions; the thicker is the line, the more is the traffic on the aisle. Critical crossings occur on the aisles 2-6 and 7-3, and on the aisles 8-10 and 7-9. In Table 14 the final positions for the cells are provided. The algorithm also evaluates the distance to be run by an AGV to transport an item through the process: the estimation is 46m, and is provided by the sum of the distances run through the borders of the black circles.

It is possible to introduce in this model spatial constraints (e.g. columns of the plants, no go areas, etc.). The calculation of the optimal positions will run similarly but the cells will avoid the constrained areas.

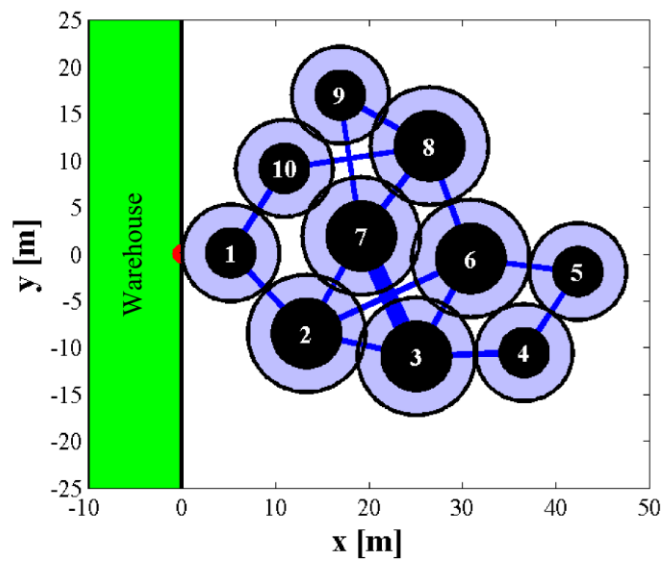

Figure 57: Final cellular layout configuration according to the algorithm applied to the case study.

Table 14: Coordinates of the centers of the process areas in their final positions.

x (m)	y (m)
2.74	1.02
10.81	-5.62
22.52	-8.12
34.06	-9.76
39.84	-1.12
28.38	2.33
16.69	4.77
24.01	14.37
14.50	17.85
8.49	10.04

6.4.3. Discrete Event Simulation

Once the optimal positions of the process areas have been defined, a simulation of the performance of the system should be run. The x and y coordinates of the centers of the process areas are transformed in inputs for the DES model.

For the new cellular layout two main AGV strategies are compared. In the first, the vehicles are only used to transport items through the workstations; in the second, the vehicles assist an item through the whole process, since it enters the process until it leaves the line, staying idle when the item undergoes manufacturing operations. The choice among these two scenarios, performed during the design stage, can affect the flexibility of the line and its capability in dealing with different takt times with respect to the initial target.

For this work, the DES model has been built using Flexsim® [112]. The system however can be run in other simulation software that have a specific module for simulating AGVs (i.e. Plant Simulation®, Automod®, etc.). The simulation model during running is shown in Figure 58. The positions of the workstations correspond to the output of Figure 57. The other inputs of the simulation model are the data contained in Table 13: operations and set up times, numbers of stations and the list of processes. Finally, the AGVs in the virtual model simulates the real machines in terms of performances: speed equal to 1.2m/s and acceleration equal to 0.4m/s². The workstations (Flexsim element “processor”) have different dimensions: big stations are process areas with 2 parallel machines (they can process two workpieces at a time as shown in figure) whereas small stations represent process areas with only one machine. The workpiece changes colour after each step of the process, thus it is possible to identify the current step of the process that the workpiece is undergoing. On the contrary, with a traditional serial layout, it is easier to identify the situation of the workpiece as it follows a linear path from start of the line to the end.



Figure 58: DES model of the optimized layout.

Simulations have been performed with different sizes for the AGVs fleet. The results of the simulations for both scenarios can be summarized as follows:

- Scenario 1 – AGVs not assigned:** The optimal number of vehicles active in the shop-floor is 19. A quantity of AGVs lower than 19 results in efficiency (i.e. the ratio between the effective and the desired cycle time) loss, thus in higher values for the takt time and a lower demand can be satisfied. Conversely, a number of AGVs greater than this value does not lead to efficiency benefits. Figure 59 shows the distributions of time for the different states of the AGV. With a fleet of 19 AGVs on average the time spent by each vehicle is composed by a 65% of idle condition (i.e. the AGV is waiting for the call from an item that needs to be transported) and a 30% of transport condition (i.e. the AGV is moving charged with an item).

The remaining 5% is spent in the empty transport condition (i.e. the AGV is moving to a different position without the item).

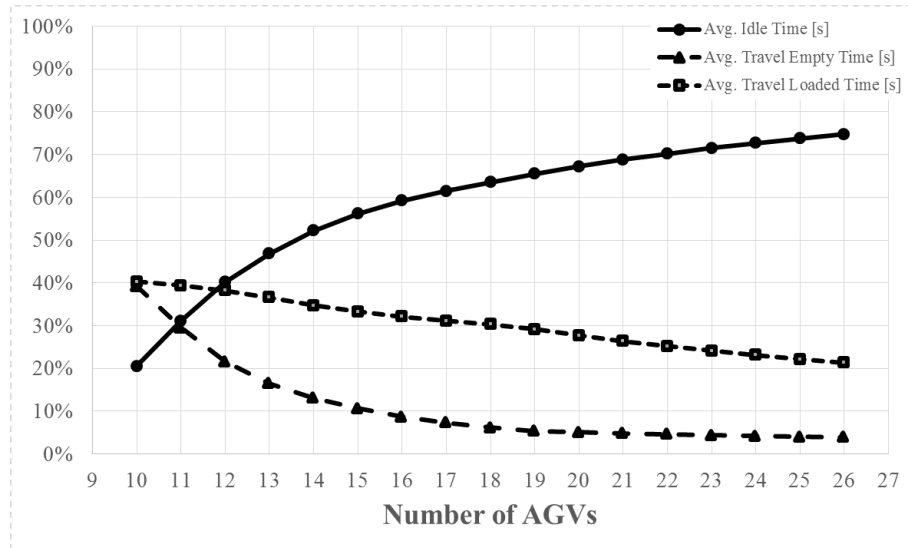

Figure 59: Percentages of average times spent in different conditions for scenario 1

- Scenario 2 – AGVs assigned to one item:** The minimum number of AGVs to reach an efficiency equal to 98% (i.e. acceptable value of technical efficiency for an assembly line) is equal to 18. Similarly to the previous case, Figure 60 shows the distribution of times and status of the AGVs. Times are determined by the process of the assisted item. Therefore the ration between the different status does not change like in the first scenario. However, with a fleet of 19 AGVs the times spent in the different conditions are similar to scenario 1: 30% is spent in transport loaded; 5% is spent in transport idle; 65% is waiting.

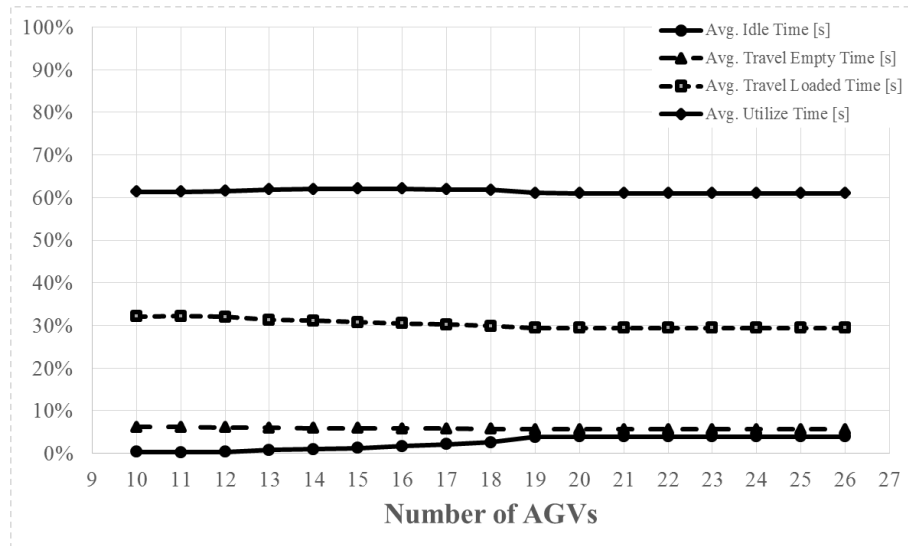

Figure 60: Percentages of average times spent in different conditions for scenario 2

In conclusion the average result for the same fleet size is similar between the two scenarios; however, the punctual behavior is different. In scenario 1, the vehicle is free to assist different items,

hence the time spent in each workstation is not fixed. On the contrary, in scenario 2 the waiting time is set (small fluctuations may occur due to process variability);

However, this simulation model does not consider battery duration and charging areas. As a matter of fact this constraint can greatly influence the simulation. Solutions for battery charging are however many, one of them being the possibility to install a charging equipment inside the stations where the AGV in the second scenario waits for the process to be completed. Indeed, scenario 1 appears to be a more flexible option in terms of variable demand different products processed on the same cellular layout.

6.4.4. AGVs and KBE application

For our KBE application this is a perfect example of how a KBE application needs to be maintained and updated with new configuration rules if the modules of the line change and evolve. The next step for this promising work is to implement it in the KBE line configurator. By exploiting the modular approach of the KBE configurator (Figure 26) the algorithm for calculating the optimal positioning of the process areas could be an added module to the existing framework. For the integration within the KBE application the optimal configuration algorithm will be run automatically from the bill of process and will automatically send position outputs to the DES model builder.

The application would be enriched by an additional module that could be useful for instance for the evaluation of different *as-if scenario*. In particular the replacement of a traditional conveyor system with a fleet of AGVs.

6.4.5. Conclusions and Next Steps

As anticipated, important technological constraints are neglected for this analysis. The main aim of this work is to show the existence of different paradigms for powertrain assembly lines, to define a methodology to tackle them and integrate the KBE configurator with new features for changed scenarios. In the next steps of this work the technological aspects of the integration of AGVs in powertrain assembly lines will be better defined. This will allow a more robust analysis of the new system.

The algorithm and simulation of AGVs line will be improved in the following aspects:

- i. Considering real dimensions (x, y) of the cells, not only radius;
- ii. Evaluation of the impact on mixed-model assembly lines; the introduction of an item that follows a different process sequence is considered to be the real added value of a flexible transport system. However the initial optimization of the cellular layout is based on the starting bill of process. The introduction of a new process will indeed influence the positions of the process areas, thus it should be taken into consideration from the very beginning.
- iii. Evaluate the impact of traffic management on the system. Crossing should be avoided and rules for precedencies should be defined. Indeed, waiting times for precedencies can negatively influence the line throughput.
- iv. Evaluation of the impact of the use of AGVs in an integrated production-logistic system. In the described case study, the AGVs are used for conveying items from one process area to

another. Nonetheless the use of AGVs for the logistic of components and supplies to the single workstations can lead to more advantages at a plant level.

Note: The work presented in this Chapter has been developed in cooperation with dr. Gianluca D'Antonio, Ph.D. Candidate in Production Systems and Industrial Design at Politecnico di Torino.

6.5. Engineering KPIs

The work presented in this chapter derives from the request at a company level to find an adequate index for measuring performance of non-production activities. As a matter of fact, in parallel with the automation of the design, one of the aims of this thesis is to quantitatively measure improvements in design performances. The thesis focused on the application of KBE configuration to assembly lines and presented a preliminary evaluation of the registered benefits. However, the evaluation was mostly qualitative except for the measurement of the reduction of design times. Performance measurement is often referred to as the process of quantifying actions, but also to establish quality-related dimensions of performance. Nevertheless it is difficult to find an objective measure of quality in design, especially during proposal engineering where high flexibility is required.

KPIs for the design departments in engineering companies like Comau were hardly considered relevant in the past, since the metrics are usually related to the financial aspects of projects. Also, the scarcity of engineering performance indices in literature can be attributed to the difficulty in defining a general accepted KPI system, because the design processes and products of each company are very different.

The work presented here was conducted to investigate ways of measuring performances of an engineering company. However, this activity is focused on detailed design engineering activities (P4) rather than proposal engineering (P2, see Figure 2). In fact, it is presented as related work as it was not used to evaluate benefits of the KBE application due to both limitation of the approach and objective difficulties in applying quality measurements to proposal engineering.

6.5.1. Methodology

The appraisal of design quality not always has a desirable result. In the studies performed by Busby at different engineering companies problems were caused by people in downstream functions making incorrect diagnoses. People in other functions were not always knowledgeable or even systematic in their diagnostic method. In some cases they had no training on the product in question [113]. One of the greatest contributions to the research on how to assess performances in design activities comes from Busby. In one of his works [114], he identified four main reasons to investigate performance measurement of engineering design: (I) effectiveness of quantitative goal setting and feedback for overall increase of performances; (II) apparent existence of unproductive behaviours among engineering designers (e.g. settling on the first solution found instead of looking for more nearly optimal designs); (III) performance measurement is normative (i.e. “you cannot control what you do not measure”); (IV) existing performance measure in most engineering organizations have deficiencies, they usually ignore important outcomes other than time and cost.

The methodology used for this work has been to first (i) review the existing literature on the topic, then (ii) analyse the main factors that could be inserted into the evaluation of design performances and (iii) try to find an appropriate performance indicator and finally (iv) apply the defined indicator to real world data.

The literature on the topic of quantitative measurement of non-production activities is not very rich. Most of the papers tackle the analysis of big engineering projects (e.g. construction projects) to find

ways to measure design quality instead of using merely financial indexes to measure the success of the project. Except from Busby [113, 114] and few others notable examples [115] there are almost no papers that investigate specifically the measurement of performances in design tasks.

The analysis conducted in Comau focused on the main indicators currently used during the engineering phase in both business units for system design: Body Assembly and Powertrain Assembly. The index for measuring performance in projects are based on design hours, costs and number of delays and design changes. They can be organized into three categories (Figure 61):

- In terms of efficiency, the most common indicators that estimate performances based on major project axis: time, cost and delays.
- Level of Standardization is relevant to understand the role and the profitability of the standard product on an engineering project.
- Quality indicators measure the output of the engineering phase based on the number of nonconformities attributable to Engineering (P4) and the level of customer satisfaction about the technical solutions.

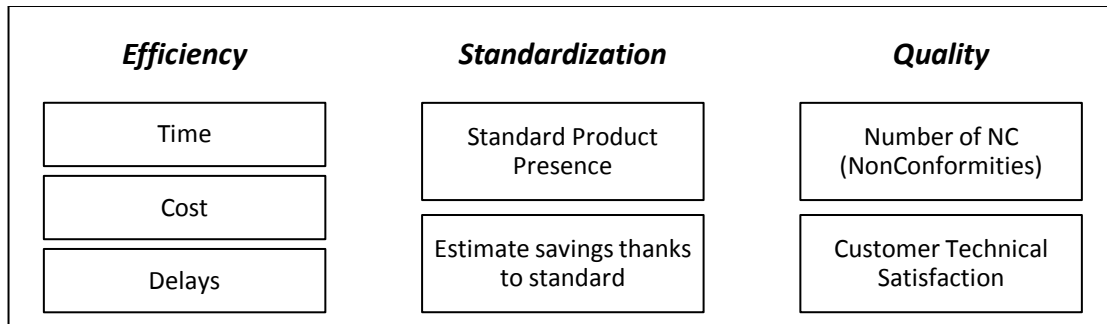

Figure 61: Main performance indicators for Engineering (P4) activities within Comau.

6.5.2. Design Performance with Frontier Analysis

An holistic approach proposed by Busby [114] to measure engineering performance involving all the metrics above can be offered by the Frontier Analysis or Data Envelopment Analysis (DEA).

This method, often used to assess the efficiency of non-production activities, intuitively assigns to each parameter an axis where the scores for each project are recorded, that is, given n parameters, each project can be identified by a point in a n -coordinates dimension. The points of best performance form an efficient frontier-surface (i.e. the convex hull of the cloud of points), therefore if a project is not on the surface, its score can be evaluated as its distance from the surface (Figure 62 shows the simplified model for a 2-dimensional space).

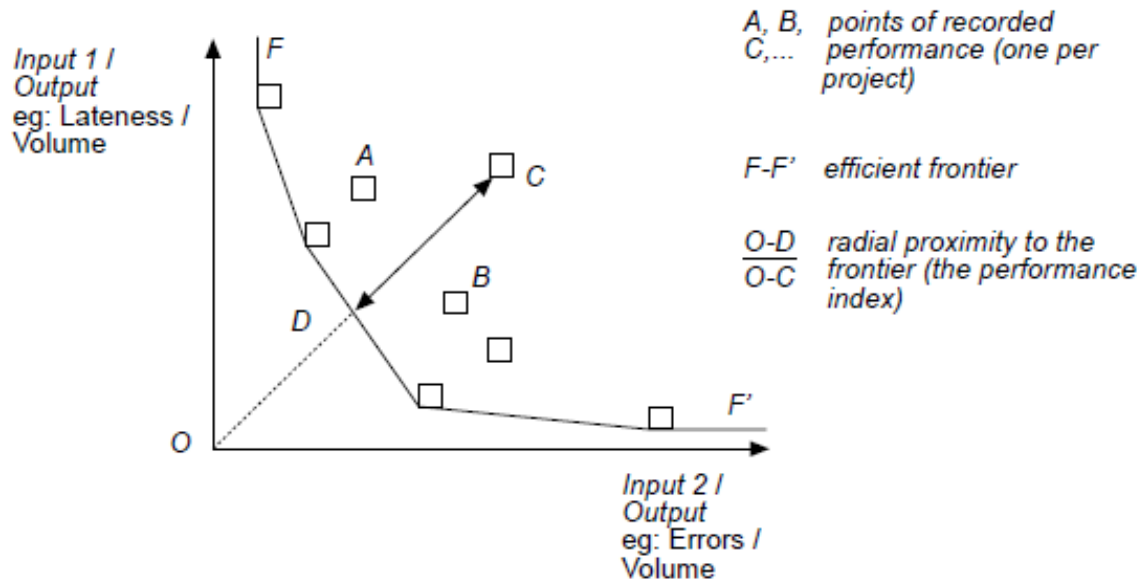

Figure 62: The principle of Frontier Analysis for 2 inputs over one output parameter (bi-dimensional graph taken from [114])

The principle of DEA is the definition of performance or efficiency as:

$$performance = \frac{output}{input} = \frac{Y_N}{X_N};$$

In particular, for project N, output Y_N and input X_N are a linear combination of the output and input parameters, respectively $Y_{j,N}$ and $X_{i,N}$.

More widely, it is important to notice that:

- *Outputs* $Y_{j,N}$ are all the factors that contribute to improve performance (e.g. number of drawings). The higher the value of outputs the better.

$$Project\ N\ Output = Y_N = \sum_j \alpha_j Y_{j,N} \quad \text{with } \alpha_j = \text{multiplier for output parameter } j;$$

- *Inputs* $X_{i,N}$ are all the factors that contribute to reduce performance (e.g. number of errors and delays). The higher the value of inputs, the lower the performance of the design.

$$Project\ N\ Input = X_N = \sum_i \beta_i X_{i,N} \quad \text{with } \beta_i = \text{multiplier for input parameter } i;$$

The mathematical foundations of DEA is based on the maximization of the ratio

$$\max \mu_N(\alpha, \beta) = \frac{Y_N}{X_N} = \frac{\sum_j \alpha_j Y_{j,N}}{\sum_i \beta_i X_{i,N}};$$

with the help of linear programming optimization algorithms[116].

Therefore, following Operational Research methods, the previous problem can be transformed in its equivalent form[117]:

$$\max Y_N = \sum_j \alpha_j Y_{j,N};$$

with the constraints:
$$\begin{cases} \frac{Y_N}{X_N} \leq 1 \text{ or } \sum_j \alpha_j Y_{j,N} - \sum_i \beta_i X_{i,N} \leq 0 \\ \sum_i \beta_i X_{i,N} = 1 \\ \alpha_j \geq 0 \text{ and } \beta_i \geq 0 \text{ for all } j \text{ and } i \end{cases}$$

and it represents a linear optimization in terms of the multipliers α_j and β_i .

The Frontier Analysis allows to identify a single performance factor by gathering many variables, belonging to various categories, that would be difficult to combine otherwise. As consequence, in the application developed for Comau case, it operates as collector of different KPIs.

Recalling the approach used in literature, the inputs and outputs for Comau Powertrain Engineering have been identified in Figure 63. In particular:

- i. *Number of Non-Conformities (Errors)* identified by the quality department and assigned to engineering have a negative effect on Engineering performance.
- ii. *Delays in Engineering Milestones* adversely affect Engineering efficiency.
- iii. *Number of drawing revisions* measures the reworks and can be used as an indicator for Engineering quality, the more frequent are the revisions, the lower is the performance.
- iv. *Hours of Engineering* are an input for the project, obviously, the less resources are used, the better is Engineering efficiency.
- v. *Number of special drawings* developed by technical teams has a positive effect on performance, the higher this number - other things being equal - the better is Engineering.
- vi. *Cost of ordered material* quantifies the output and gives tangible evidence of the number of drawings released, thus, it favourably affects engineering efficiency.
- vii. *Percentage of standard drawings* influences positively the technical productivity.

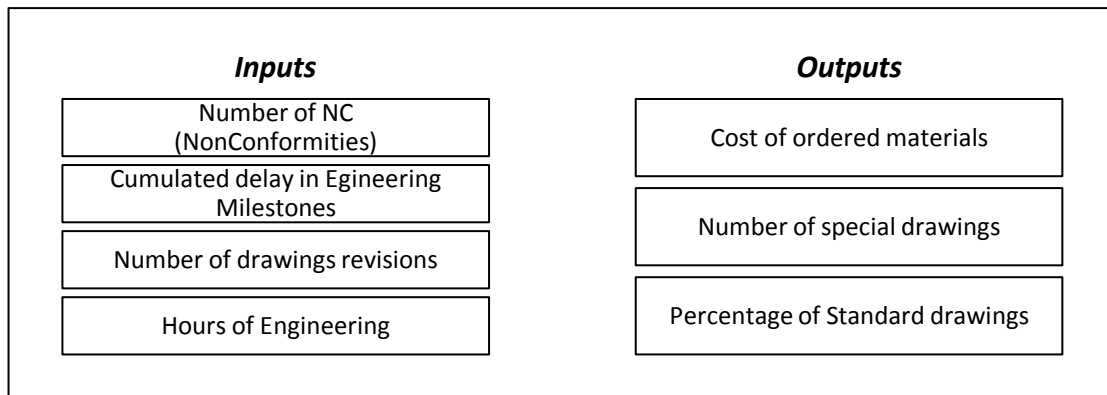

Figure 63: List of inputs and outputs used for the DEA

The required data for several projects have been collected with the support of Comau Quality department reports, project team reports, Enovia® PLM system and SAP® records. Then, the mathematical model has been adapted to an Excel® VBA macro, which is able to elaborate the iterations of the Linear Programming solver.

Table 15: Example of DEA application for Comau Mechanical Engineering

	Input 1	Input 2	Input 3	Input 4	Output 1	Output 1	Output 1	Results
Project	Delays	NC	N^rev.	Hours	CoM	N^spec dwg	Std %	Efficiency
A	20	125	250	25000	18	2000	50	31%
B	25	44	200	12000	1	100	20	2%
C	25	80	100	6000	10	6000	55	100%
D	12	23	150	10000	11	1200	12	41%
E	20	125	250	1000	15	2000	5	100%
F	25	44	200	12000	16	100	20	5%
G	50	80	48	6000	5	500	12	22%
H	26	100	150	10000	2	100	20	2%
I	80	125	458	25000	200	2000	5	30%
L	0	0	10	200	16	100	80	100%

The suitability of this method for engineering efficiency measurements is mainly due to the following reasons:

- DEA does not require fixed weights, the technique is able to integrate an arbitrary number of factors into a single index without requiring their relative importance.
- DEA handles outcome and environmental variables, because it excludes the effect of noise when defining the efficient frontier.

Among the drawbacks of this approach there are:

- DEA allows only the calculation of relative efficiency. If all projects have similar levels of efficiency they will all be on the efficiency frontier but this does not necessarily guarantee a good performance level.
- For enhancing the efficiency and the reliability of its results, DEA needs a large set of data both inputs and outputs. At the same time, the more projects are analysed the more effective the analysis will be.
- It ignores technical accomplishment embodied in the design and environmental variables like product complexity and product novelty – no basis for distinguishing between performance shortfalls that are attributable to the design process and those attributable to its environment.

6.5.3. Engineering KPIs and the KBE application

One of the pressing requirements for a provider of automation solutions is to try to automate as much as possible its internal processes, including design tasks. KBE practices are typically tied to organisational objectives and are intended to achieve specific outcomes. However, as seen from this

research study, quantifying the benefits deriving from the introduction of KBE approaches is not a trivial task. The research work presented in this section is a first attempt to provide a solution to this problem applied to the detailed engineering phase within Comau. Nevertheless, at this stage there is no application of this performance measuring system to the KBE approach implemented. The only measurement of performance applied is described in section 5.6 and aims at a preliminary evaluation of the KBE application for its further development. However, once the application runs, it will be possible to collect enough data and include into the KBE application an indicator for measuring performances of the preliminary design.

Based on the described DEA analysis and on the variables that characterize the proposal engineering phase we can speculate on a possible performance indicator shown in Table 16. The table is inspired to the case study here described. The number of non-conformities is not part of the indicator as it is something that is not measured during the proposal phase. The cost of the ordered material is substituted by the value (i.e. price) of the proposal/offer.

Table 16: Hypothesis for the application of DEA to the developed KBE application.

	Input 1	Input 2	Input 3	Output 1	Output 2	Output 3	Results
Proposal/ Offer	Delays	N [^] rev.	Hours	Project Value (Mio €)	N [^] dwgs	Std %	Efficiency
Proposal 1	3	2	25000	18	3	50	x%
.	-	-	-	-	-	-	y%
.	-	-	-	-	-	-	z%
Proposal n	-	-	-	-	-	-	a%

6.5.4. Conclusions and Next Steps

The presented work briefly summarizes the investigation of ways to measure efficiency in design activities within an engineering company. This work started from an analysis of the existing techniques in the literature and an analysis of the main indicators collected in Comau (i.e. where data are available and can be used for analysis). Then, the DEA was selected as a suitable analysis for our case study, useful to aggregate several data into a unique indicator of efficiency. Some data for real projects were collected from different sources and used for running an excel solver for the analysis.

This works is reported to show the efforts that the company is doing in trying to measure design tasks to improve its efficiency. Furthermore, this is to testify the importance given at a company level to the improvement of engineering phase, including measurement of performances and automation of design processes.

Despite all these efforts, the DEA is not currently implemented in everyday engineering projects. This is due to the large number of data necessary to run this index. Actually, these data are hardly tracked during the projects and the lack of a small portion of these data may jeopardize the reliability of the entire calculation. On top of this, the same DEA has some limitations that were discussed in the previous section. Moreover there are general problems in introducing quantitative measurements in design activities. The designer and engineers fear the possible decrease in quality of the design or in other aspects than are not measured by the index (e.g. innovative content of the design).

Among the next steps for this research work there is need to implement the measurement of performance in the day to day work of engineers and designers. For this purpose it will be necessary to raise awareness on the importance of measuring performances and to gain full acceptance of these kinds of measurements among designers.

7. Conclusions

Abstract

This final chapter aims at summing up the main discussion points of this research study and draw some conclusions. The KBE approach has demonstrated to be successful in reducing design times and the number of resources needed. Furthermore we collected a positive feedback from the same designers and engineers about the ability of the configuration tool to support their day-to-day work. Based on the results obtained from the tests the initial research questions of this study are tackled and answered. Moreover, some of the limitations of this approach and difficulties encountered during the empirical research are indicated. Finally, some directions for further research are highlighted. These conclusions have been disseminated in various international publications and will be further spread as new results are achieved.

7.1.Introduction

The study was set out to explore the concept of improving design efficiency in an engineering company by re-using existing knowledge and automating design. This work has investigated the pressing requirements at a company level to improve design performances and at the same time cope with the challenge of retaining company knowledge in an increasingly global context. Nowadays most engineering companies have to face a fierce and global competitions. Engineering design is largely experience based activity and most of the time spent by designers is used for retrieving past technical solutions. Therefore, one of the main assets to leverage for reaching a competitive advantage is identified as internal knowledge. This asset, however is at risk due to high turnovers and rapid global expansion. The study sought to answer these two research questions:

- *How can a knowledge based approach improve design performances in an engineering company?*
- *How can a knowledge based approach help retaining existing technical knowledge in an engineering company?*

The general theoretical literature on this subject is inconclusive on several crucial questions on the benefits of the application of these approaches to day to day engineering activities. This study deep dived into the company processes to analyse as-is design processes and existing technical knowledge in the specific area of powertrain assembly line design. In the area of manufacturing systems, design automation approaches have found little space in the existing literature. The study, therefore, tried to answer another research questions.

- *How can design automation and knowledge based approach be applied to the preliminary design of manufacturing systems in an industrial environment?*

The research used the existing technical knowledge to develop a working prototype of a design automation application for the preliminary design of powertrain assembly lines. The application was finally tested among designers to evaluate the possible benefits.

7.2.Empirical Findings

The empirical findings are summarized in the relevant empirical chapters (i.e. chapters 5 and 6). Here below the main findings related to the research questions are summarized.

How can a knowledge based approach improve design performances in an engineering company?

- The automation of repetitive design tasks can have a direct impact on design performance related to time and costs. In the present study, a reduction of design times of around 30% was achieved with a relative saving in terms of design costs.
- Automation of repetitive design tasks can improve the design output in terms of quality and reduce the number of errors. The automatic generation of a CAD generative model of an assembly line using predefined components and configuration rules brings the risk of CAD related errors almost to zero.
- The use of the knowledge based application registered a good acceptance level by the designers that were satisfied by a tool able to help them and reduce the amount of

repetitive design tasks. Better satisfaction of the designers is expected to lead to better design quality. The impact on customer was not measure however it is believed that a better quality design will lead to an improved customer satisfaction.

How can a knowledge based approach help retaining existing technical knowledge in an engineering company?

- The knowledge based approach has its foundation on the company knowledge. However it gives a structured approach for the clarification and formalization of existing knowledge. At the same time, we found that the implemented methodology has been beneficial to the company work. The designers interviewed were happy to share their knowledge in an attempt to improve their work by avoiding repetitive design tasks. The activity of collecting existing technical knowledge is desirable as it allows to re-collect all the work done and set a shared starting point for any further research activity.
- The automation of some design tasks can lead to a reduction of the technical competences needed for design. This is to say that for instance the design of a 3D layout requires design skills that may not always and at the same time be globally available in an engineering company. The automation of this design task can solve this problem and respond to the lack of people competences and technical knowledge.

How can design automation and knowledge based approach be applied to the preliminary design of manufacturing systems in an industrial environment?

- The variability of solutions that can be found in an assembly line is almost infinite. Similarly the modular approach applied to the configuration of assembly lines reduces the number of standard components but increases exponentially the number of possible configurations. As a conclusion of this work we found that the variability found in the design of a Powertrain Assembly Lines is great but can be overcome with a proper standardization of solutions, especially considering that considered products are a restricted group (i.e. engine, cylinder head and transmissions) and their assembly processes are quite consolidated. In the development of the configurator it is important to define correctly the scope of the application and the level of detail of the configuration process. The low level of detail guarantees the automation of the design of an assembly line. These level of detail allows also the CAD systems to generate the virtual prototype of the line. Using a higher level of detail would dramatically increase the complexity of the application and jeopardizing the achieved benefits. A higher degree of complexity can compromise also the visualization of the assembly line with the CAD software. The use of the modular approach avoided the consideration of all the detailed parameters of a complex product/process that would have been too expensive in terms of development time and definition.
- The design automation of the preliminary layout of a powertrain assembly poses a series of challenges that are completely new to product design. Certainly, among the kinds of analysis that are typical of a manufacturing system there is discrete event simulation (see section 6.2) that is neglected by the commercially available KBE software packages. However in the literature there are some examples of automation of the generation of a simulation model. Furthermore assembly systems are subject to a huge variability depending on the product

being assembled but also on the same evolving technical solutions. This study tried to give some answers in section 6.4 however most of the commercial tools for design automation are not suitable for the design of complex manufacturing systems in their different aspects.

7.3. Discussions and Implications

At a company level it is easy to encounter difficulties and people that believe that knowledge acquisition, knowledge engineering and knowledge management are not relevant for the success of the organization. This may be true in some cases but it is a shared opinion among top executives from around the world that one of the areas of activity that offers the greatest potential for productivity gain over the next 15 years is “knowledge management” [118]. Knowledge and competences are therefore believed to be crucial to remain competitive in an increasingly global market with fierce competition.

The current situation of the preliminary design of production lines within Comau poses a series of challenges: it is an experienced based activity with some uncertainties and inefficiencies. The need for a reduction in errors and delays is a pressing requirement from the market which is growing at fast pace on a global scale with always more specific requirements from the customers. This work added to the research knowledge an industry-related study of the implementation of knowledge based engineering techniques and design automation in the form of a configurator application for the preliminary design of powertrain assembly lines.

This study built upon similar investigations on knowledge based systems applied to manufacturing systems [1, 51, 103] but sought to add a direct evaluation in an industrial environment. On top of the existing KBE approaches in the literature we tried to implement a cost-benefit analysis and build a solid business case for implementation in the day to day work. In line with the previous works, the study found that there are evident benefits by the application of these approaches in an industrial environment. However the commercially available software packages should be revised to reach a level of desirability needed for the diffusion in an industrial context. At present, the existing package need probably too much effort to be customized to the single case study compared to the achieved benefits.

Furthermore, many engineering companies nowadays are trying to implement modular approaches to their designs so to better apply engineering-to-order reducing time and costs. By leveraging this trend it makes a lot of sense to formalize this modular approach and implement it in a configurator application to improve the preliminary design and sales of customized designs. In this work we described the experience of a successful company provider of manufacturing equipment. The research done had positive feedback as well as positive consequences on the day to day business.

7.4.Limitations

The study has offered an evaluative perspective on a complete design automation approach and was conducted in an industrial environment through direct contact with designers and engineers. As a direct consequence of this methodology, the study encountered a number of limitations, which need to be considered.

- i. Programming skills. As evident from the previous sections, practicing knowledge based engineering (not using KBE applications!) is mostly about programming software applications to enhance the level of automation in the engineering design process. The activity of knowledge collection and formalization is an undoubted added value for a company. The implementation of the application for the configurator requires, though, competences that are difficult to find among mechanical and automation engineers.
- ii. Maintenance and Update of the knowledge base. As soon as the knowledge base gets out of date the system becomes almost useless. On the contrary, the more knowledge is added to the application and the more effective the system will become.
- iii. Development of KBE systems present on the market. The commercially available tools are usually costly and need a high level of customization to be suitable for an industrial implementation.
- iv. The fear that designers have of the system limiting their creative work. The engineer or designer, from the observation work and the interview would like to have a tool able to support and facilitate their work without being too rigid and limiting creativity. On the contrary, the plant configuration tool is a tool to support and foster innovation at a company level.
- v. Intellectual property of the company, which is considered to be at risk in a direct interaction with the customer in an open bid. Finally, a present limitation to the implementation of such a system could be the.
- vi. Complexity vs usefulness balance: One of the main challenges of this work has been the identification of the right level of simplification to guarantee an acceptable balance between usefulness of the application and its complexity. The idea that was stress by the company was to adopt an 'increasing complexity' approach. Therefore the first attempt is to start with the lowest complexity possible but preserving the benefits of the application.

The adoption of a design automation approach for an engineering company is not as simple as it may seem. As every big change it needs a widespread acceptance and most of all time. If we take as example the case of mechanical design in the last 40 years it evolved constantly. In the same company, mechanical designers that started designing using the drawing table, they had to learn how to use CAD tools for 2D drawings and now they started designing in 3D. These same people will shortly be confronted with software that can automate most repetitive design task. It is not correct to speak about limitations but it is the time needed for accepting such a big change that can slow done the adoption of the approach.

Throughout this work, some of the details of the company-related knowledge have been omitted. The overall description of the thesis shows the methodology and the application but does not intentionally goes into the details of the existing technical solutions property of Comau for obvious confidentiality reasons.

7.5.Dissemination

Throughout the research project, several papers were published to present the work and disseminate the achieved results. The dissemination strategy developed on two main axis due to the

nature of the work: internally (i.e. within the company) and externally (i.e. within the scientific community).

Four different papers were published during the three-year project: 3 published in the proceedings of international conferences one of which was awarded the Best Paper Award prize and 1 on a peer-reviewed journal. All the main external dissemination activities are summarized in Table 17.

Table 17: Main dissemination activities related to this thesis.

Conference/Journal	Title	Status
ICIDM 2014: International Conference on Innovative Design and Manufacturing, 11-15 August, Montreal, Canada	<i>“Feasibility of an Assembly Line Layout Configuration Based on a KBE Approach”</i>	Published in proceedings (Awarded best paper in the <i>Design</i> session)
ETFA 2014: 19th IEEE Conference on Emerging Technologies and Factory Automation, 16-19 Sept 2014, Barcelona, Spain	<i>“Automatic Configuration of a Powertrain Assembly Line Layout Based On a KBE Approach”</i>	Published in proceedings + poster
ASME IMECE 2015: International Mechanical Engineering Congress & Exposition– Houston (TX), USA	<i>“Configuration Rules for Assembly Line Layouts: an Integrated Approach for the Preliminary Design”</i>	Published in proceedings
International Journal of Computer Applications in Technology	<i>“A Knowledge Based Framework for Automated Layout Design in an Industrial Environment”</i>	Accepted for publication

At a company level, the project has undergone periodical reviews. The final results of the application will be presented at the end of the *Proregio* (6.3) project to have a more complete output and validation.

7.6.Next Steps and Future Work

In spite of the good results achieved, some short term research actions will be investigate to complete the developed application. The following tasks will be needed to enrich and complete the modular software architecture shown in Figure 26:

- Discrete Event Simulation and Line optimization (section 6.2 and 6.3 inside ProRegio); the theme of DES is a crucial improvement for completing the early stage design of production systems.
- Formalize regional requirements (section 6.3 ProRegio); by the end of the EU supported research project, regional features of manufacturing systems will be formalized and included in the configuration process.
- AGV module with factory layout algorithm (section 6.4);
- Increase output type; develop interface module to be able to generate different CAD format in output (see section 6.1)
- Connect with costs database; improve the connection between the currently used estimating tool and the KBE application to have a precise quotation. Nevertheless the as is situation of the KBE application allows to assign a cost property to each component but this aspect has to be improved with a full integration of the two tools.

- Explore the possibilities offered by web technologies that are rapidly spreading in the development of configurator applications.

However, the scale of this debate is extensive and multifaceted. To generate satisfactory results for the full adoption of design automation strategies in engineering companies there is need for more case studies at industrial level and further developments in the area of study. Exploring the following as future research strategies can facilitate the attainment of this goal:

- Generalization of the scope the system will be generalized to cover a broader spectrum of automotive manufacturing technologies, including Body-in-White (BiW) assembly (i.e. metal joining technologies for chassis). In the future the scope should go beyond the manufacturing sector to include general purpose manufacturing systems.
- Knowledge Re-Use: An interesting evolution of artificial intelligence to engineering design is the use of case-based reasoning (CBR) approaches. In the developed application the knowledge about past projects is foreseen to be simply stored in the databases. In a case-based reasoning system usually the knowledge is indexed so that similarity metric allow to retrieve in the database existing knowledge relevant to the design[119, 120].
- Include the electrical and automation part of the design of a manufacturing systems. In the era of the *Industry 4.0* concept a great part of the design of a production line is taken by electrical and automation engineering. Not only it will save more and more time in design tasks but it is a crucial aspect to be taken into consideration for further research.

In conclusion, this work introduced a methodology to approach the early stage design of powertrain assembly systems. The methodology relied on a knowledge based framework: the research extracted domain knowledge and rules from the experts, formalized the acquired knowledge and implemented it into a knowledge based application. The developed application is integrated with already existing engineering tools for design (2D and 3D CAD). The methodology has been developed starting from industrial requirements and tested in a real world scenario. The study sought to answer three main research questions, firstly (i) demonstrating an improvement in design performances (i.e. reduction of 30% in design times a positive feedback from the designers), secondly (ii) collecting and formalizing for the first time configuration rules and knowledge and making it available to non-technical people and thirdly (iii) applying knowledge based techniques to a complex manufacturing system with a high variability of solutions. The same application improved the quality of the output of the preliminary design introducing the use of a 3D layout and the of an approximate assembly line balancing algorithm. On top of the existing KBE approaches in the literature we tried to implement a cost-benefit analysis and build a solid business case for implementation in the day to day work. In spite of the limitations encountered during the real world implementation and the implementations needed for a full functionality of the applications, the achieved results are promising and testify the usefulness of a design automation approach for powertrain assembly line based on the formalization and diffusion of available technical knowledge. Building on this conclusions, directions for research are suggested for further additions to the body of knowledge in this promising yet far from application field of the automation of design.

Bibliography

- [1] K. Efthymiou, K. Sipsas, D. Mourtzis, and G. Chryssolouris, "On an Integrated Knowledge based Framework for Manufacturing Systems Early Design Phase," *Procedia CIRP*, vol. 9, pp. 121-126, // 2013.
- [2] W. J. C. Verhagen, P. Bermell-Garcia, R. E. C. van Dijk, and R. Curran, "A critical review of Knowledge-Based Engineering: An identification of research challenges," *Advanced Engineering Informatics*, vol. 26, pp. 5-15, 1// 2012.
- [3] S. Peters, G. Lanza, J. Ni, J. Xiaoning, Y. Pei-Yun, and M. Colledani, "Automotive manufacturing technologies – an international viewpoint," *Manufacturing Rev.*, vol. 1, p. 10, 2014.
- [4] A. Ascheri, G. Colombo, M. Ippolito, E. Atzeni, and F. Furini, "Feasibility of an assembly line layout automatic configuration based on a KBE approach," in *Proceedings of the 2014 International Conference on Innovative Design and Manufacturing, ICIDM 2014*, 2014, pp. 324-329.
- [5] KPMG. (2013, 22/04/2015). Available: <http://www.kpmg.com/KZ/ru/IssuesAndInsights/ArticlesAndPublications/Documents/KPMG-s-Global-Automotive-Executive-Survey-2013.pdf>
- [6] I. Haq, R. Monfared, R. Harrison, L. Lee, and A. West, "A new vision for the automation systems engineering for automotive powertrain assembly," *International Journal of Computer Integrated Manufacturing*, vol. 23, pp. 308-324, 2010.
- [7] J. Johansson, "Design Automation Systems for Production Preparation: Applied on the Rotary Draw Bending Process," Department of Product and Production Development, Chalmers University of Technology, Göteborg, 2008.
- [8] A. Kusiak and F. Salustri, "Computational Intelligence in Product Design Engineering: Review and Trends," *Systems, Man, and Cybernetics, Part C: Applications and Reviews, IEEE Transactions on*, vol. 37, pp. 766-778, 2007.
- [9] G. Pahl, W. Beitz, J. Feldhusen, and K.-H. Grote, *Engineering Design: A Systematic Approach*: Springer, 2007.
- [10] S. L. Mountney, J. X. Gao, and S. Wiseall, "A knowledge system to support manufacturing knowledge during preliminary design," *International Journal of Production Research*, vol. 45, pp. 1521-1537, 2007/04/01 2007.
- [11] Oliver Wyman, "Automotive Manager," 2014.
- [12] Y. Koren, *The Global Manufacturing Revolution: Product-Process-Business Integration and Reconfigurable Systems*: Wiley, 2010.
- [13] R. Harrison, A. Colombo, A. West, and S. Lee, "Reconfigurable modular automation systems for automotive power-train manufacture," *International Journal of Flexible Manufacturing Systems*, vol. 18, pp. 175-190, 2006.
- [14] Comau. (2016, 05/03/2016). <http://www.comau.com/en/our-competences/powertrain/modules>.
- [15] L. Langeveld, *Product design with embodiment design as a new perspective*: Intech Open, 2011.
- [16] T. W. Simpson, J. R. Maier, and F. Mistree, "Product platform design: method and application," *Research in engineering Design*, vol. 13, pp. 2-22, 2001.
- [17] J. B. Dahmus, J. P. Gonzalez-Zugasti, and K. N. Otto, "Modular product architecture," *Design studies*, vol. 22, pp. 409-424, 2001.
- [18] A. Lowe, C. McMahan, and S. Culley, "Information access, storage and use by engineering designers, part 1," *The Journal of the Institution of Engineering Designers*, vol. 30, pp. 30-32, 2004.

Bibliography

- [19] A. Lowe, C. McMahon, and S. Culley, "Information access, storage and use by engineering designers, part 2," *The Journal of the Institution of Engineering Designers*, vol. 30, pp. 23-26, 2004.
- [20] N. Papakostas, K. Efthymiou, G. Chryssolouris, S. Stanev, J. Ovtcharova, K. Schäfer, *et al.*, "Assembly Process Templates for the Automotive Industry," in *3rd CIRP Conference on Assembly Technologies and Systems. Trondheim, Norway: Tapir Uttrykk*, 2010.
- [21] M. Lohtander, M. Lanz, J. Varis, and M. Ollikainen, "Breaking down the manufacturing process of sheet metal products into features," *Mechanika*, vol. 2(64), pp. 40-48, 2007.
- [22] J. Stjepandić, W. J.C. Verhagen, H. Liese, and P. Bermell-Garcia, "Knowledge-Based Engineering," in *Concurrent Engineering in the 21st Century*, J. Stjepandić, N. Wognum, and W. J.C. Verhagen, Eds., 1 ed: Springer International Publishing, 2015, pp. 255-286.
- [23] V. Naranje and S. Kumar, "A knowledge-based system for strip-layout design for progressive deep drawing dies," *International Journal of Computer Applications in Technology*, vol. 48, pp. 222-234, 2013.
- [24] R. R. Inman, D. E. Blumenfeld, N. Huang, and J. Li, "Designing production systems for quality: Research opportunities from an automotive industry perspective," *International Journal of Production Research*, vol. 41, pp. 1953-1971, 2003/01/01 2003.
- [25] M. Colledani, L. Bolognese, D. Ceglarek, F. Franchini, C. Marine, and A. Mistry, "Multi-objective Early-stage Design of Automotive Hybrid Assembly Lines," *Procedia CIRP*, vol. 28, pp. 125-130, // 2015.
- [26] A. Qattawi, A. Mayyas, M. Abdelhamid, and M. A. Omar, "Incorporating quality function deployment and analytical hierarchy process in a knowledge-based system for automotive production line design," *International Journal of Computer Integrated Manufacturing*, vol. 26, pp. 839-856, 2013/09/01 2013.
- [27] N. Papakostas, G. Pintzos, M. Matsas, and G. Chryssolouris, "Knowledge-enabled Design of Cooperating Robots Assembly Cells," *Procedia CIRP*, vol. 23, pp. 165-170, // 2014.
- [28] M. B. Raza and R. Harrison, "Information Modeling and Knowledge Management Approach to Reconfiguring Manufacturing Enterprises," *International Journal of Advanced Information Technology (IJAIT)*, vol. 1, pp. 1-20, 2011.
- [29] R. Harrison, A. A. West, and L. J. Lee, "Lifecycle engineering of future automation systems in the automotive powertrain sector," in *Industrial Informatics, 2006 IEEE International Conference on*, 2006, pp. 305-310.
- [30] J. X. Wang and M. L. Roush, *What every engineer should know about risk engineering and management*: CRC Press, 2000.
- [31] D. G. Ullman, *The mechanical design process* vol. 2: McGraw-Hill New York, 1992.
- [32] C. B. Chapman and M. Pinfold, "Design engineering—a need to rethink the solution using knowledge based engineering," *Knowledge-based systems*, vol. 12, pp. 257-267, 1999.
- [33] G. La Rocca, "Knowledge based engineering: Between AI and CAD. Review of a language based technology to support engineering design," *Advanced Engineering Informatics*, vol. 26, pp. 159-179, 4// 2012.
- [34] G. La Rocca, *Knowledge based engineering techniques to support aircraft design and optimization*: TU Delft, Delft University of Technology, 2011.
- [35] S. K. Chandrasegaran, K. Ramani, R. D. Sriram, I. Horváth, A. Bernard, R. F. Harik, *et al.*, "The evolution, challenges, and future of knowledge representation in product design systems," *Computer-Aided Design*, vol. 45, pp. 204-228, 2// 2013.
- [36] M. R. Lee and T. T. Chen, "Revealing research themes and trends in knowledge management: From 1995 to 2010," *Knowledge-Based Systems*, vol. 28, pp. 47-58, 4// 2012.
- [37] M. Cederfeldt, "Planning Design Automation : A Structured Method and Supporting Tools," Department of Product and Production Development, Chalmers University of Technology, Göteborg, 2007.

Bibliography

- [38] B. Vermeulen, "Knowledge based method for solving complexity in design problems," Aerospace Engineering, TU Delft, Delft University of Technology, Delft, 2007.
- [39] M. Stokes and M. Consortium, *Managing engineering knowledge: MOKA: methodology for knowledge based engineering applications*: Professional Engineering Publ., 2001.
- [40] C. Chapman, S. Preston, M. Pinfold, and G. Smith, "Utilising enterprise knowledge with knowledge-based engineering," *International journal of computer applications in technology*, vol. 28, pp. 169-179, 2007.
- [41] I. O. Sanya and E. M. Shehab, "A framework for developing engineering design ontologies within the aerospace industry," *International Journal of Production Research*, vol. 53, pp. 2383-2409, 2015/04/18 2014.
- [42] Stanford University, "Protégé," ed. California, USA: Stanford University, Stanford University School of Medicine, Stanford Medical Informatics, 2004.
- [43] I. O. Sanya and E. M. Shehab, "An ontology framework for developing platform-independent knowledge-based engineering systems in the aerospace industry," *International Journal of Production Research*, vol. 52, pp. 6192-6215, 2014/10/18 2014.
- [44] F. Laallam, M. Kherfi, and S. Benslimane, "A survey on the complementarity between database and ontologies: principles and research areas," *International Journal of Computer Applications in Technology*, vol. 49, pp. 166-187, 2014.
- [45] K.-Y. Kim, S. Chin, O. Kwon, and R. D. Ellis, "Ontology-based modeling and integration of morphological characteristics of assembly joints for network-based collaborative assembly design," *Artificial Intelligence for Engineering Design, Analysis and Manufacturing*, vol. 23, pp. 71-88, 2009.
- [46] K. Efthymiou, K. Sipsas, D. Melekos, K. Georgoulas, and G. Chryssolouris, "A Manufacturing Ontology Following Performance Indicators Approach," in *Proceedings of 7th International Conference on Digital Enterprise Technology (DET2011), Athens, 2011*, pp. 28-30.
- [47] Q. Ma and X. Liu, "Review of knowledge based engineering with PLM," in *Applied Mechanics and Materials*, 2008, pp. 127-131.
- [48] D. Guerra and R. Young, "Knowledge maintenance in knowledge-based product development systems," in *Knowledge and Technology Integration in Production and Services*, ed: Springer, 2002, pp. 403-410.
- [49] D. Monticolo, S. Mihaita, H. Darwich, and V. Hilaire, "An agent-based system to build project memories during engineering projects," *Knowledge-Based Systems*, vol. 68, pp. 88-102, 9// 2014.
- [50] D. Mourtzis and M. Doukas, "Knowledge Capturing and Reuse to Support Manufacturing of Customised Products: A Case Study from the Mould Making Industry," *Procedia CIRP*, vol. 21, pp. 123-128, // 2014.
- [51] K. Efthymiou, K. Sipsas, D. Mourtzis, and G. Chryssolouris, "On knowledge reuse for manufacturing systems design and planning: A semantic technology approach," *CIRP Journal of Manufacturing Science and Technology*, vol. 8, pp. 1-11, 1// 2015.
- [52] X. Gogouvitis and G. C. Vosniakos, "Construction of a virtual reality environment for robotic manufacturing cells," *International Journal of Computer Applications in Technology*, vol. 51, pp. 173-184, 2015.
- [53] P. Lovett, A. Ingram, and C. Bancroft, "Knowledge-based engineering for SMEs—a methodology," *Journal of materials processing technology*, vol. 107, pp. 384-389, 2000.
- [54] G. Schreiber, *Knowledge engineering and management: the CommonKADS methodology*: MIT press, 2000.
- [55] G. Colombo, D. Pugliese, and C. Rizzi, "Developing DA Applications in SMEs Industrial Context," in *Computer-Aided Innovation (CAI)*. vol. 277, G. Cascini, Ed., ed: Springer US, 2008, pp. 69-82.

Bibliography

- [56] G. Colombo and F. Mandorli, "Evolution in Mechanical Design Automation and Engineering Knowledge Management," in *Innovation in Product Design*, ed: Springer, 2011, pp. 55-78.
- [57] C.-H. Chen and Z. Rao, "MRM: A matrix representation and mapping approach for knowledge acquisition," *Knowledge-Based Systems*, vol. 21, pp. 284-293, 5// 2008.
- [58] Y.-J. Chen, Y.-M. Chen, and M.-S. Wu, "Development of an Ontology-based Expert Recommendation System for Product Empirical Knowledge Consultation," *Concurrent Engineering: R&A*, vol. 18, pp. 233-253, / 2010.
- [59] Siemens. (20/04). *Siemens Rulestream Engineer-to-Order*. Available: http://www.plm.automation.siemens.com/it_it/products/open/rulestream/
- [60] N. R. Milton, *Knowledge acquisition in practice: a step-by-step guide*: Springer Science & Business Media, 2007.
- [61] J. Zheng, M. Zhou, J. Mo, and A. Tharumarajah, "Background and foreground knowledge in knowledge management," in *Global Engineering, Manufacturing and Enterprise Networks*, ed: Springer, 2001, pp. 332-339.
- [62] I. Nonaka, H. Takeuchi, and K. Umemoto, "A theory of organizational knowledge creation," *International Journal of Technology Management*, vol. 11, pp. 833-845, 1996.
- [63] C. Janani and T. Devi, "Study and Analysis of Knowledge Acquisition Techniques for Acquiring Knowledge on Product Functionality," *International Journal of Software and Web Sciences*, vol. 5, pp. 68-73, 2013.
- [64] N. Milton. (2015, 01/01). *PCPACK5*. Available: <http://www.epistemics.co.uk/Notes/207-0-0.htm>
- [65] P. Akhavan, M. Jafari, and M. Akhtari, "Exploration of knowledge acquisition techniques in tunnel industry: The case study of iran tunnel association," *International Journal of Business and Management*, vol. 6, pp. 245-255, 2011.
- [66] Y. Koren and M. Shpitalni, "Design of reconfigurable manufacturing systems," *Journal of manufacturing systems*, vol. 29, pp. 130-141, 2010.
- [67] M. Rossoni, "A Knowledge-Based Engineering Approach to Automate the Assembly Lines Configuration," MSc Mechanical Engineering, Department of Mechanical Engineering - Methods and Tools for Product design, Politecnico di Milano, Milano, Italy, 2015.
- [68] T. Tsai and R. Sato, "A UML model of agile production planning and control system," *Computers in Industry*, vol. 53, pp. 133-152, 2// 2004.
- [69] C. Forza and F. Salvador, "Managing for variety in the order acquisition and fulfilment process: The contribution of product configuration systems," *International journal of production economics*, vol. 76, pp. 87-98, 2002.
- [70] IDEF. (2015, 02/03/2015). <http://www.idef.com/idef0.htm>.
- [71] C. Becker and A. Scholl, "A survey on problems and methods in generalized assembly line balancing," *European journal of operational research*, vol. 168, pp. 694-715, 2006.
- [72] M. E. Salveson, "The assembly line balancing problem," *Journal of Industrial Engineering*, vol. 6, pp. 18-25, 1955.
- [73] O. Battaïa and A. Dolgui, "A taxonomy of line balancing problems and their solution approaches," *International Journal of Production Economics*, vol. 142, pp. 259-277, 2013.
- [74] A. P. Staudacher and A. Pozzetti, *Progettazione dei sistemi produttivi: criteri e metodologie*: Hoepli, 2003.
- [75] J. W. Fowler and O. Rose, "Grand challenges in modeling and simulation of complex manufacturing systems," *Simulation*, vol. 80, pp. 469-476, 2004.
- [76] T. Bray, J. Paoli, C. M. Sperberg-McQueen, E. Maler, and F. Yergeau, "Extensible markup language (XML)," *World Wide Web Consortium Recommendation REC-xml-19980210*. <http://www.w3.org/TR/1998/REC-xml-19980210>, vol. 16, 1998.

Bibliography

- [77] L. Hvam, A. Haug, and N. H. Mortensen, "Assessment of benefits from product configuration systems," in *13th Workshop on Configuration, ECAI 2010, the 19th European Conference on Artificial Intelligence*, 2010.
- [78] K. R. Ladeby, *Applying Product Configuration Systems in Engineering Companies*: DTU Management, 2009.
- [79] M. Salchner, S. Stadler, M. Hirz, J. Mayr, and J. Ameye, "Multi-CAD approach for knowledge-based design methods," *Computer-Aided Design and Applications*, pp. 1-13, 2016.
- [80] T. Williams, C. Eden, F. Ackermann, and A. Tait, "The effects of design changes and delays on project costs," *Journal of the Operational Research Society*, pp. 809-818, 1995.
- [81] S. S. Amidharmo, "Critical success factors for the implementation of a knowledge management system in a knowledge-based engineering firm.," Queensland University of Technology, 2014.
- [82] A. Corallo, "Enhancing product development through knowledge-based engineering (KBE) A case study in the aerospace industry," *Journal of Manufacturing Technology Management*, vol. 20, p. 13, 2009.
- [83] C. L. Emberey, N. Milton, J. Berends, M. Van Tooren, S. Van der Elst, and B. Vermeulen, "Application of knowledge engineering methodologies to support engineering design application development in aerospace," in *7th AIAA Aviation Technology, Integration and Operations Conference (ATIO)*, 2007.
- [84] S. Bhasali and E. Brynjolfsson, "Measuring the impact of electronic data management on information worker productivity," *MIT Center for Digital Business Research Brief*, vol. 10, 2008.
- [85] R. Laubacher and G. Papandrea, "Activity based performance measurement: impact of simulation in new product development," in *MIT Center for Digital Business Seminar, December, 2007*.
- [86] Z. Degraeve, E. Labro, and F. Roodhooft, "An evaluation of vendor selection models from a total cost of ownership perspective," *European Journal of Operational Research*, vol. 125, pp. 34-58, 2000.
- [87] E. J. Reddy, C. Sridhar, and V. P. Rangadu, "Knowledge Based Engineering: Notion, Approaches and Future Trends," *American Journal of Intelligent Systems*, vol. 5, pp. 1-17, 2015.
- [88] Wikipedia. (2016, 01/01). *Knowledge Based Engineering*. Available: https://en.wikipedia.org/wiki/Knowledge-based_engineering
- [89] Autodesk. (2015, 01/02/2016). *Inventor ETO*. Available: <http://www.autodesk.com/products/inventor-engineer-to-order/overview>
- [90] Tacton. (2015, 01/02). *Tacton Works Engineer*. Available: <http://www.tacton.com/solutions/design-automation/>
- [91] Citius Software Corporation. (2015, 01/02). *KB Max*. Available: <http://www.kbmax.com/>
- [92] Design Parametrics. (2015, 01/02). *Design++*. Available: <http://designpower.com/design++/>
- [93] Drive Works. (2015, 01/02). *Drive Works* Available: <http://www.driveworks.co.uk/>
- [94] Technosoft. (2015, 01/02). *Adaptive Modeling Language*. Available: <http://www.technosoft.com/application-software/adaptive-modeling-language/>
- [95] Genus Software Inc. (2015, 01/02). *Genus Designer*. Available: <http://genussoftware.com/>
- [96] PACE Aerospace Engineering and Information Technology. (2015, 01/02). *Pacelab Suite*. Available: <https://www.pace.de/products/preliminary-design/pacelab-suite.html>
- [97] Vision KBE. (2015, 01/02). *KBE Works*. Available: <http://www.visionkbe.com/>
- [98] Questel. (2015, 01/02). *Orbit*. Available: <https://www.questel.com/#>
- [99] W. Kühn, "Digital factory: simulation enhancing the product and production engineering process," in *Proceedings of the 38th conference on Winter simulation*, 2006, pp. 1899-1906.

Bibliography

- [100] Autodesk. (2016, 01/02). *Factory Design Suite 2016*. Available: <http://www.autodesk.it/suites/factory-design-suite/overview>
- [101] E. Yücesan and J. W. Fowler, "Logistics systems, simulation analysis of Simulation analysis SIMULATION ANALYSIS OF MANUFACTURING AND LOGISTICS SYSTEMS," in *Encyclopedia of production and manufacturing management*, ed: Springer, 2000, pp. 687-697.
- [102] JaamSim. (2015). *JaamSim*. Available: <http://jaamsim.com/>
- [103] W. Terkaj and M. Urgo, "Virtual factory data model to support performance evaluation of production systems," in *Proceedings of OSEMA 2012 workshop, 7th international conference on formal ontology in information systems, Graz, Austria, 2012*, pp. 24-27.
- [104] S. Bergmann and S. Strassburger, "Challenges for the automatic generation of simulation models for production systems," in *Proceedings of the 2010 Summer Computer Simulation Conference, 2010*, pp. 545-549.
- [105] European Commission. (2015). *ProRegio*. Available: <http://www.h2020-proregio.eu/>
- [106] E. Commission, "HORIZON 2020 – WORK PROGRAMME 2014-2015," in *General Annexes - Technology readiness levels (TRL)*, ed, 2013.
- [107] T. Ganesharajah, N. G. Hall, and C. Sriskandarajah, "Design and operational issues in AGV-served manufacturing systems," *Annals of Operations Research*, vol. 76, pp. 109-154, 1998.
- [108] I. F. Vis, "Survey of research in the design and control of automated guided vehicle systems," *European Journal of Operational Research*, vol. 170, pp. 677-709, 2006.
- [109] J. A. Tompkins, J. A. White, Y. A. Bozer, and J. M. A. Tanchoco, *Facilities planning*: John Wiley & Sons, 2010.
- [110] M. Rajasekharan, B. A. Peters, and T. Yang, "A genetic algorithm for facility layout design in flexible manufacturing systems," *International Journal of Production Research*, vol. 36, pp. 95-110, 1998.
- [111] R. D. Meller and K.-Y. Gau, "The facility layout problem: recent and emerging trends and perspectives," *Journal of manufacturing systems*, vol. 15, pp. 351-366, 1996.
- [112] FlexSim. (2015, 01/10). *FlexSim*. Available: <https://www.flexsim.com/>
- [113] J. Busby, "Problems in error correction, learning and knowledge of performance in design organizations," *IIE transactions*, vol. 31, pp. 49-59, 1999.
- [114] J. Busby and A. Williamson, "The appropriate use of performance measurement in non-production activity: the case of engineering design," *International Journal of Operations & Production Management*, vol. 20, pp. 336-358, 2000.
- [115] A. Kline, E. Tsang, B. Aller, J. Asumadu, J. Morgan, S. Beyerlein, *et al.*, "Creating and using a performance measure for the engineering design process," in *2003 ASEE Annual Conference and Exposition: Staying in Tune with Engineering Education, 2003*.
- [116] J. Zhu, *Quantitative models for performance evaluation and benchmarking: data envelopment analysis with spreadsheets and DEA excel solver*: Springer, 2003.
- [117] H. D. Sherman, Zhu, Joe, *Service Productivity Management: Improving Service Performance using Data Envelopment Analysis (DEA)*: Springer, 2006.
- [118] E. Economist Intelligence Unit, "Forefront 20/20: Economic, Industry and Corporate Trends," London 2006.
- [119] P. Cunningham and A. Bonzano, "Knowledge engineering issues in developing a case-based reasoning application," *Knowledge-Based Systems*, vol. 12, pp. 371-379, 1999.
- [120] I. Watson and F. Marir, "Case-based reasoning: A review," *The knowledge engineering review*, vol. 9, pp. 327-354, 1994.

List of Figures

Figure 1: Structure of the thesis.....	22
Figure 2:Comau General Processes	25
Figure 3: Overview of the product range covered by the "Powertrain" definition (adapted from Comau PA institutional presentation).	26
Figure 4: Location of Comau PA centres around the world.....	27
Figure 5: Example of Modularity Concept for an automatic station (Smart Rob).....	31
Figure 6: Example of equipment modularity applied to a SmartRob automatic workstation. The components highlighted in orange are part of the structure of the station. The elements highlighted in green are typical standard support components while the blue area indicate a process components.	32
Figure 7: Proposal Flow representation with main actors involved.....	35
Figure 8: Manufacturing cost commitment during design (taken from [31]).....	40
Figure 9: Logical Architecture of the research study.....	47
Figure 10: Six-step methodology for development of KBE industrial applications.....	50
Figure 11:Overall architecture of the knowledge framework to be implemented.....	52
Figure 12: The role of the knowledge engineer in the traditional and new generation KBE approaches.....	56
Figure 13: Valve Train assembly.....	57
Figure 14: Multi-fold definition of Knowledge from Milton [60]	59
Figure 15: Main KA techniques used for the specific case study.	62
Figure 16: Example of an Excel spreadsheet collecting non-formalized knowledge.	63
Figure 17: UML scheme of the powertrain assembly line.	65
Figure 18: Basic Function Block of the IDEF0 notation	66
Figure 19: IDEF0 representation of the design process.....	67
Figure 20: Detail of the processes inside the Product Analysis block	68
Figure 21: Detail of the processes inside the Logical Design block	69
Figure 22: Detail of the processes inside the Output Generator block	70
Figure 23: Graphical representation of the line balancing algorithm logic.	76
Figure 24:Hierarchical and object-oriented structure within Rulestream Architect.....	79
Figure 25: Rulestream Architect interface for properties definition.....	79
Figure 26: Modularity of the KBE software application.....	80
Figure 27: Interaction of the configurator with external tools	81
Figure 28: Integration of the configurator with existing IT tools.	83
Figure 29: User interface for the NX integration of the application.	85
Figure 30: Example of reference plane for an automatic station and a conveyor module.	85
Figure 31: Starting window of the KBE application.	88
Figure 32: General Information window of the application.	89
Figure 33: Production volume and product requirements.	91
Figure 34: Operation Tab	92
Figure 35: Operation Editor tab.	92
Figure 36: Conveyor tab.....	93

List of Figures

Figure 37: Output of the KBE application for a cylinder head assembly line with different cycle times. ..	94
Figure 38: The four evaluation pillars of the methodology	96
Figure 39: Estimated time saving for the preparation of a technical proposal of a powertrain assembly line.....	97
Figure 40: The four evaluation pillars with respect to the α test case of the application.	101
Figure 41: Feedback loops created by design changes during engineering projects (taken from [80])...	102
Figure 42: The four evaluation pillars applied to the case of design changes.	103
Figure 43: Stakeholder map with regards to the development of a KBE application	105
Figure 44: Estimated return on investment in terms of design hours.	108
Figure 45: Review of KBE software packages over time adapted from [33]. Coloured black, and followed by dark green arrows the main KBE vendors. The main KBE languages are represented in blue. The KBE most recent software packages that focus on sales support are coloured orange.	110
Figure 46: Distribution of patents by Assignee over time for the term "knowledge based engineering".....	112
Figure 47: Distribution of patents number over time for the term "knowledge based engineering"	113
Figure 48: Distribution of patents by Assignee over time for the term "design automation".	114
Figure 49: Distribution of patents number over time for the term "design automation"	114
Figure 50: Overview of the tool comprised in Factory Design Suite 2016 by Autodesk	120
Figure 51: Example of a 3D Layout of a Powertrain Assembly Line (Comau USA).	121
Figure 52: Example of a DES Model.....	124
Figure 53: Overall architecture of ProRegio WP4 for process and plant design.	127
Figure 54: Logical flow for Comau Use Case inside ProRegio	128
Figure 55: Overall architecture for the optimization tool tailored to Comau use case (part of the conceptual layer).	129
Figure 56: Interaction mechanism between cells (process areas).	135
Figure 57: Final cellular layout configuration according to the algorithm applied to the case study.	137
Figure 58: DES model of the optimized layout.....	138
Figure 59: Percentages of average times spent in different conditions for scenario 1.....	139
Figure 60: Percentages of average times spent in different conditions for scenario 2.....	139
Figure 61: Main performance indicators for Engineering (P4) activities within Comau.	143
Figure 62: The principle of Frontier Analysis for 2 inputs over one output parameter (bi-dimensional graph taken from [114])	144
Figure 63: List of inputs and outputs used for the DEA.....	145

List of Tables

Table 1: Ten Process Clusters that group of all the assembly tasks present in PA lines.	29
Table 2: Difference between MEDEA and the presented approach.	51
Table 3: Sequence of the operations needed to perform powertrain valve assembly on a cylinder head.	58
Table 4: Types of knowledge and relative acquisition techniques and examples.	59
Table 5: Examples of line configuration rules formalized and explained.	71
Table 6: Examples of flexibility levels of different technical solutions for an operation of a cylinder head assembly.	90
Table 7: Feedback results of the preliminary test.	99
Table 8: Time needed for the application development	106
Table 9: SWOT analysis for the applied KBE approach.	109
Table 10: Main KBE commercial software tool.	111
Table 11: Differences between outputs in the different proposal flows scenario.	122
Table 12: Bill of Process for the cylinder head assembly including camshafts.	133
Table 13: List of process areas with machine optimization.	136
Table 14: Coordinates of the centers of the process areas in their final positions.	137
Table 15: Example of DEA application for Comau Mechanical Engineering.	146
Table 16: Hypothesis for the application of DEA to the developed KBE application.	147
Table 17: Main dissemination activities related to this thesis.	154

