



POLITECNICO DI TORINO
Repository ISTITUZIONALE

Near term perspectives for fusion research and new contributions by the Ignitor program

Original

Near term perspectives for fusion research and new contributions by the Ignitor program / Coppi, B.; Airoidi, A.; Albanese, R.; Ambrosino, G.; Berta, S.; Bianchi, A.; Bombarda, F.; Cardinali, A.; Cenacchi, G.; Chilton, L.; Clai, G.; Detragiache, P.; Faelli, G.; Frattolillo, A.; Frosi, P.; Giunchi, G.; Grasso, G.; Mantovani, S.; Migliori, S.; Penco, R.; Pierattini, S.; Pironti, A.; Pizzicaroli, G.; Ramogida, G.; Rebusco, P.; Rubinacci, G.; Sassi, M.; Villone, F.; Zhou, T.C.; Zucchetti, M.. - ELETTRONICO. - (2010), pp. 1-12. ((Intervento presentato al convegno 23rd IAEA Fusion Energy Conference tenutosi a Daejeon, South Korea nel 11-16 ottobre 2010.

Availability:

This version is available at: 11583/2628391 since: 2016-09-12T18:48:16Z

Publisher:

International Atomic Energy Agency

Published

DOI:10.13140/RG.2.1.1423.9765.

Terms of use:

openAccess

This article is made available under terms and conditions as specified in the corresponding bibliographic description in the repository

Publisher copyright

(Article begins on next page)

Near Term Perspectives for Fusion Research and New Contributions by the Ignitor Program*

B. Coppi^{1,9}, A. Airoidi³, R. Albanese³, G. Ambrosino³, S. Berta⁵, A. Bianchi⁴, F. Bombarda², A. Cardinali², G. Cenacchi³, L. Chilton⁹, G. Clai¹, P. Detragiache¹, G. Faelli⁶, A. Frattolillo², P. Frosi², G. Giunchi⁷, G. Grasso⁵, S. Mantovani⁸, S. Migliori¹, R. Penco⁵, S. Pierattini¹, A. Pironti³, G. Pizzicaroli², G. Ramogida², P. Rebusco⁹, G. Rubinacci³, M. Sassi², F. Villone³, T.C. Zhou⁹, M. Zucchetti⁸.

¹ENEA, Italy; ²Associazione Euratom-ENEA, Italy; ³Consorzio CREATE, Naples, Italy; ⁴Ansaldo Nucleare, Genoa, Italy; ⁵Columbus Superconductors, Genoa, Italy; ⁶Ignitor Project, Piacenza, Italy; ⁷Edison, Milan, Italy; ⁸Politecnico di Torino, Italy. ⁹M.I.T., Cambridge MA, US.

E-mail contact of main author: coppi@mit.edu

Abstract. The main advances made within the Ignitor program, that is aimed at investigating the physics of fusion burning plasmas near ignition, are described. In particular, the operation of the machine in the H and I regimes at the 10 MA plasma current levels has been considered and analyzed. The unique properties of the plasmas that can be generated by operating the machine with reduced parameters (lower magnetic fields and plasma currents) relative to those needed to achieve ignition are identified. A key feature of this operation is the relatively fast duty cycle that can be maintained. The Ideal Ignition Conditions, under which the density barrier due to bremsstrahlung emission in high density plasmas is removed, can be attained in this case. The plasma heating cycles are identified for which the contribution of ICRH is used both to enter the H-regime and to optimize the time needed for ignition. The on going effort to set up a test ICRH facility is described. The initial results (2 km/sec) of the high speed pellet injection system developed for Ignitor and operated at Oak Ridge are reported. The combined structural analysis and integration of the entire machine core (Load Assembly) is discussed. The adopted control system for both the machine and the plasma column has been designed and is described. The design solutions of the vertical field coils made of MgB₂ and operating at 10 K have been identified and the relevant R&D program is underway. The analysis of the Caorso site and of its facility for the operation of the Ignitor with approved safety standards is completed. The relevant results are being made available for the operation of Ignitor at the Trinita site within the framework of the Italy-Russia agreement on the joint construction and operation of the Ignitor facility. A development effort concerning the advanced diagnostic systems that is being carried out for fusion burning plasma regimes is described. An initial analysis of the characteristics of a neutron source based on a system of Ignitor-like machines is reported.

1. Introduction

The fact that a DT fusion reactor capable of producing useful energy needs to approach ignition conditions is widely accepted by now, and the possibility to use DT burning devices as neutron sources has received considerable attention lately. These are additional motivations to the science driven objective that Ignitor has of investigating the physics of igniting fusion plasmas. In particular, these involve the excitation of new kinds of collective modes and an expected important role of self-organization processes. The Ignitor machine has been the first proposed and designed with this purpose, and the development of the Ignitor program has been sustained by continuous progress in the investigation of high-density plasmas with high magnetic axisymmetric configurations as well with helical configurations. One of the main driving factors of the Ignitor machine ($R_0 \cong 1.32$ m, $a \times b \cong 0.47 \times 0.83$ m², triangularity $\delta \cong 0.4$) is the poloidal field pressure [$B_p^2 / (2\mu_0)$] that can contain, under macroscopically stable conditions for the entire plasma column, the peak plasma pressure ($p_0 \cong 3-3.5$ MPa) corresponding to ignition [1]. The toroidal maximum magnetic field on axis (excluding the paramagnetic contribution due to the poloidal plasma current) that the machine can produce is about 13 T. The plasma configurations that can be generated with the adopted design of the poloidal magnetic field coils are of the “extended first wall” and “double X-point” type [2].

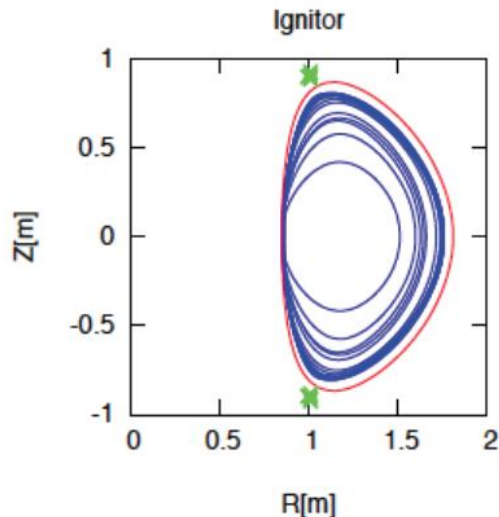

Figure 1. Plasma shape evolution from 1 to 10 MA. The green crosses mark the X points, the red line is the first wall.

2. Regimes of Operations

A variety of physical regimes can be produced with the existing Ignitor design. Maintaining a high degree of plasma purity is a necessary condition in order to achieve ignition and the ‘spontaneous’ confinement of impurities at the edge of the plasma column is an important process associated with the high density L-Regimes produced by the Alcator and the Frascati Torus program. The in depth investigation of the I-Regime within the Alcator C-Mod program [3,4] has revealed that the impurity confinement as well as the direction of the spontaneous rotation are the same as that for the L-Regime while the plasma energy confinement is superior. In order to verify the consequences of producing this regime in Ignitor, the levels of the heating power that needs be applied in order to enter it have to be reliably identified. An effort is underway within the Alcator C-Mod program to control the excitation of the 200 kHz mode (density fluctuations) that characterizes this regime and is consistent with the theory that has been carried out for it [5].

The double X-point configurations have been included in the Ignitor design in order to produce, with the appropriate level of plasma heating, the H-regime. In this case a sufficiently long confinement time for ignition is predicted on the basis of existing scalings but the possibility that impurities may not be sufficiently concentrated at the edge remains a concern.

Spontaneous rotation is expected to be present in Ignitor. This process is connected to the characteristics of the modes excited at the surface [6] of the plasma column as well as to those responsible for the transport of angular momentum from the edge toward the center. These facts do not lead to a reliable scaling for the entity of the rotation velocity and of its effects. Another important factor that is difficult to predict, given our inexperience with meaningful fusion burning plasma regimes, is the amplitude of the expected sawtooth oscillations in the central region of the plasma column.

3. Operation at Reduced Parameters

Experience shows that most of the operation time of an advanced machine is devoted to investigate plasmas whose parameters are well below the record parameters for which the machine is designed. Therefore, a comprehensive analysis has been carried out of the ‘reduced parameter’ operation of the machine with the criterion that the relevant duty cycle be appropriate

In the former configuration, the plasma current I_p can reach 11 MA with a magnetic safety factor $q_\psi \cong 3.5$; in the latter configuration, $I_p \lesssim 10$ MA, given the consequent reduction of the plasma cross section relative to the extended first wall case. The double X-point scenario (see Fig. 1) with magnetic field up to 13T, plasma current up to 10 MA and X-points on the outer surface of the plasma chamber has been analyzed by using the JETTO [2] equilibrium-transport code.

for the investigation of the plasma regimes. Thus the heating of the main magnet systems and the time necessary for their cooling that determines the interval between successive shots is evaluated in parallel to the evolution of the plasma column. For this the JETTO 1+1/2 D free-boundary transport code is utilized. Starting from the reference discharges with 11 MA plasma current (extended limiter configuration) and 10 MA (double nul configuration), plasma with $I_p \approx 7$ MA and $B_T \approx 9$ T in the latter configuration have been analyzed in detail and relevant results are summarized partly in Fig. 2.

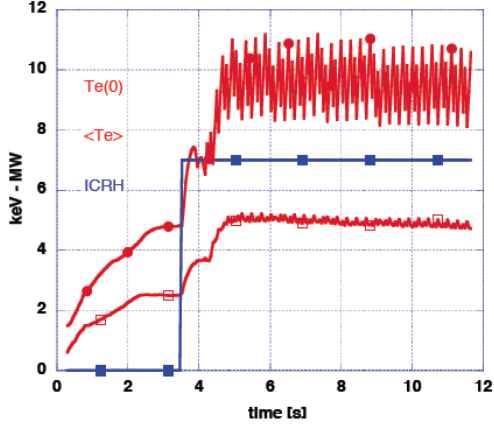

Fig. 2. 7 MA- 9 T scenario. Red lines refer to electron temperature, the blue line indicates the RF power.

a mid-range value for the pressure profile peaking is shown. Operating points well below density and beta limits and requiring an auxiliary power P_{aux} below 10 MW are obtained for all the P_{thr} scalings considered. We also note that with these parameters the current diffusion time is shorter than the flat-top time.

We note that an important objective for the Reduced Parameters program is that of the Ideal Ignition Condition where α -particle heating can compensate the loss of the bremsstrahlung radiation emission. From this point on, during a given heating cycle, the values of the plasma density can be chosen in order to optimize this cycle without the limit of the “bremsstrahlung barrier” [10].

4. The ICRH System and Relevant Theory

The ICRH system for Ignitor is designed to accelerate the achievement of ignition as well as to access the H and the I-regimes. In order to have large operating flexibility the system has been conceived with a modular configuration to optimize the launch of the RF power depending on the different plasma regimes considered. Each RF module, based on 4 high power generators,

Plasma performance has also been determined using a simplified zero-dimensional model. It was found that at these reduced parameters access to H-mode confinement is facilitated by a lower threshold power P_{thr} (three different scalings are considered, A[7], B[8], C[9]) and by the increased level of ICRF power that is available (about 10 MW) because of the lower frequency required for ion cyclotron resonance. With H-mode confinement, D-T plasmas with interesting characteristics ($T_{e0} \approx 10$ keV, $n_{e0} \approx 3 \times 10^{20} \text{ m}^{-3}$) may be produced, corresponding to a gain parameter $Q_F \approx 1$. In Fig. 5, the operating regime obtained with a zero-dimensional model assuming

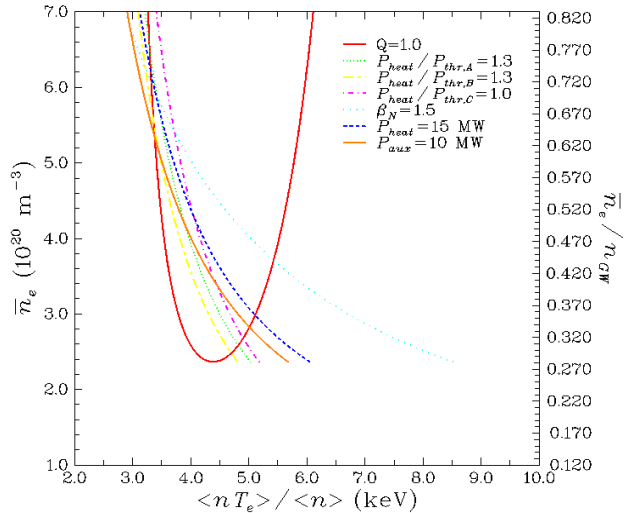

Fig. 3. POPCON plot showing an Ignitor operation regime with reduced parameters ($I_p=5$ MA, $B_T=8$ T) and H-regime confinement. Different scaling expressions for threshold power P_{thr} . D-T plasmas with $Z_{eff} = 1.3$ and $n_0 / \langle n \rangle = 1.4$, $T_0 / \langle T \rangle = 2.5$ are considered.

is able to operate in the frequency range 80-120 MHz generating a total power of 8 MW at the central frequency of 80 MHz (2 MW per generator). This value is reduced to 4 MW when the operating frequency is increased at values close to the upper side of the generator band (115 MHz). The RF power of each module is distributed over 2 RF ports through 2 antennas (one antenna per port) consisting of 4 current strap electromagnetically coupled to the plasma. A 30Ω vacuum transmission system is capable of transferring 0.4 MW of power per strap (1.6 MW per port-antenna) keeping the electric field in the vacuum region below 5 kV/cm. The RF configuration of the modules allows a full phase controls (toroidal and poloidal) of the straps through a PLL phase control.

Assuming a transmission and plasma coupling efficiency around 75%, 2 RF modules (with 8 generators, 16 straps, 4 antennae) distributed over 4 ports, can produce 6 MW with 115 MHz of RF power into the plasma for the assisted ignition process.

A detailed design of the ICRH antenna, including the Faraday shield, the current straps, the vacuum transmission lines and the vacuum feed-through, has been carried out (Fig. 4). The design of this system has been integrated with that of the plasma chamber. An innovative plug-in system has been conceived to allow a simple installation of the antenna by remote handling. Manufacturing of a prototype is underway; an improved port will be welded to the existing D-shaped prototype sector of the plasma chamber. A set of four straps will then be installed inside to test their electrical and mechanical coupling with the VTL coaxial cables. This new facility will also be used for testing welding procedures, vacuum tightness, plug-in system, and high voltage components.

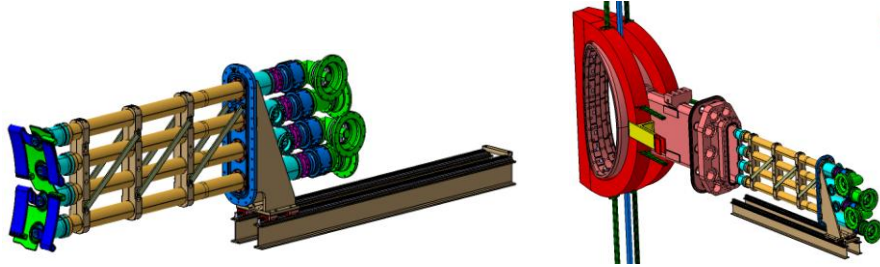

Fig.4. ICRH Antenna System (CATIA 3D Model)

As a complement to the transport analyses, the pertinent physics of the ICRH has been analyzed for all the operating scenarios of interest. In the Ignitor experiment, in fact, Ion Cyclotron Resonant Heating (ICRH) waves is planned to be used as a tool to control the plasma temperature, in particular to accelerate the achievement of ignition in the extended first wall configuration, and to facilitate the H-mode transition in the double X-point plasma configuration. The analysis of the ICRH absorption is given by numerical solution of the full wave equation in 2D geometry coupled with a 2D (in velocity space) Fokker-Planck solver. The power deposition profiles on ions and electrons are obtained and used as input data for a transport analysis. A small fraction of ^3He (1-2%) improves the wave absorption on ions near the center of the plasma column, while a substantial fraction of the coupled power is damped on the electrons in a broad radial interval of the plasma column. The transport analysis, moreover, has demonstrated that a small amount of power is sufficient to comply with the Ignitor objectives [1, 2]. The main goal concerns essentially the possibility to control the thermonuclear instability, which develops after reaching the ignition.

The expected ability of Ignitor to achieve ignition with high peak densities ($n_0=10^{21} \text{ m}^{-3}$) and relatively low temperatures makes it possible to investigate the thermonuclear instability that can develop in these regimes. As a consequence of the instability, self-heating of the plasma

by the fusion produced α -particles can lead to a significant rise of the plasma temperature and, with this, to an increase of its pressure. Then, internal plasma modes may be excited and saturate the thermonuclear instability at acceptable levels without external intervention. In the case where an internal process may not be effective, a scenario is considered whereby Ignitor is led to operate in a slightly subcritical regime, i.e. the plasma parameters are so chosen that the thermonuclear heating power is slightly less than the power lost, and a small fraction of ^3He is added to the optimal Deuterium-Tritium mixture. The difference between power lost and α -heating is compensated by additional ICRH heating that should be able to energize the minority species (minority heating) directly, which can transfer the power to the main plasma species by collisions [11].

The best frequency to operate in this “ignited scenario” where the magnetic field is ramping-up is 115 MHz when the ICRH timing is $t_{ICRH} > 3\text{sec}$, corresponding to a magnetic field $> 11\text{ T}$.

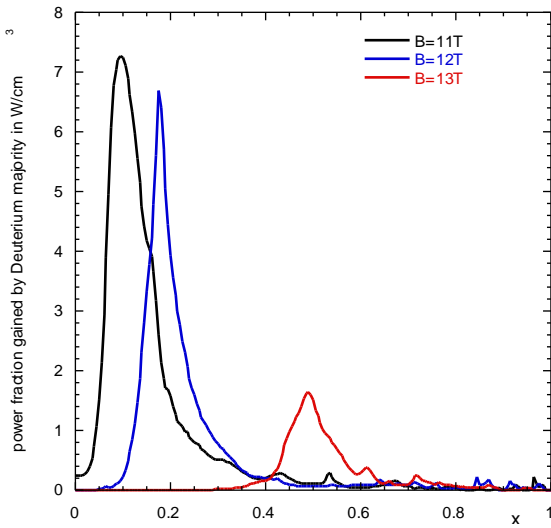

Fig. 5. Power deposition profile (in W/cm^3) on the deuterium bulk ions after collisional transfer (from energetic ^3He minority to D) for $B=11\text{ T}$ (black line), 12 T (blue line), and 13 T (red line) in the case Deuterium(50%)-Tritium(50%) plasma mixture.

For timing $< 3\text{ sec}$ and fields $< 11\text{ T}$, the operational frequency is 95 MHz. In Fig. 5 the power deposition profile in W/cm^3 is plotted vs the radial coordinate x when the magnetic field is ramping-up from 11 to 13 Tesla at the same frequency $f = 115\text{ MHz}$, and a power level of about 5 MW. The plasma is formed by Deuterium (50%), Tritium (50%) and a small fraction of ^3He ($< 2\%$). The density and temperature increase from about $5 \times 10^{20}\text{ m}^{-3}$ to $9 \times 10^{20}\text{ m}^{-3}$ and from 4 to 6 keV respectively. As such, it possible to recognize the first harmonic of ^3He and the second harmonic of tritium resonate at the same location, and when the field increases the resonance layer moves toward the periphery. The power absorbed by the ^3He (minority heating) is redistributed on the collisional time essentially to the deuterium and tritium bulk ions. The consequence is that the plasma temperature is increased, accelerating the attainment of ignition [12].

5. Design and Development of MgB_2 Equilibrium Coils

We have undertaken the design of the largest coils (about 5 m diameter) of the poloidal field system of Ignitor that produce the equilibrium vertical magnetic field and started a relevant development program. The Columbus team that is charged with this effort has identified the optimal configuration of the MgB_2 cable of which these large coils can be composed. The superconducting material MgB_2 has been selected because of its capability to operate at temperatures compatible with the cooling system selected for Ignitor, and thanks to its workability into flexible and robust km-long round wires, which represent an ideal base to realize very high current multi-strand cables. The relevant working temperature, 10 K, is achieved by an extension of the He-gas cryogenic system for Ignitor whose main function is to cool the other (copper) magnets down to 30 K. At the same time, a broader collaboration with material science laboratories (including Edison, CNISM, Frascati, GHMFL) to pursue further significant developments relevant to advanced magnetic confinement is being initiated.

The MgB_2 superconducting cable characteristics have been identified as in the following table:

Current density of a single MgB₂ strand @ 4T, 15K	1000 A/mm ²
Superconducting filling factor	20%
Single Strand diameter	1 mm
Total cross section	0.784mm ²
MgB₂ cross section in a single strand	0.15 mm ²
Critical current of a single MgB₂ strand @ 4T, 15K	152 A
Minimum number of strands to reach a current of 35kA	230

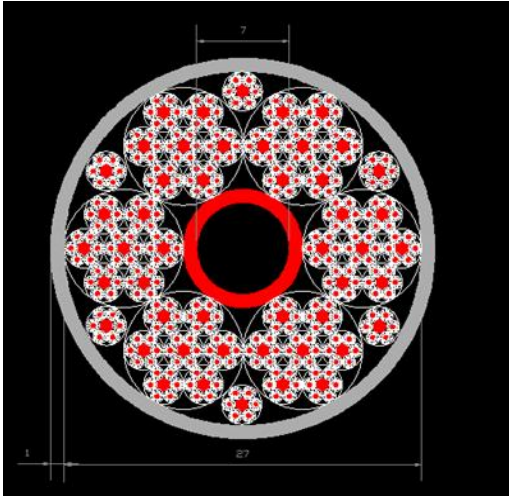

Fig. 6. Superconducting cable configuration.

A total length of about 2.2 km of such cable will be required in order to wind 9 different pancakes, in order to reach a total coil current of about 5 MA turns. The cable configuration will be very likely following the scheme reported in Fig. 6.

An inner Copper tube placed in central position has the function of carrying the cold helium gas flow throughout the windings, while the empty spaces between the outer stainless steel and the cable strands will be filled by an appropriate resin material once the curvature to the cable is realized. A total length of about 1600 km of 1 mm diameter MgB₂ wires will be required, representing to date the biggest worldwide project using this relatively new superconducting compound.

6. Detailed Machine Design and Integration

The Ignitor machine is characterized by a complete structural integration of its major components. A sophisticated Poloidal Field system provides the flexibility to produce the expected sequence of plasma equilibrium configurations during the plasma current and pressure rise. The structural concept of the machine is based on an optimized combination of the so called “bucking” and “wedging” of the toroidal field magnet coupled with the central solenoid. All components, with the exception of the vacuum vessel, are cooled before each plasma pulse by means of He gas, to an optimal temperature of 30 K, at which the ratio of the electrical resistivity to the specific heat of copper is minimum. The 3D and 2D design and integration of all the core machine components, including electro-fluidic and fluidic lines, has been produced using the Dassault CATIA-V software.

A complete structural analysis has verified that the machine can withstand the forces produced for all the main operational scenarios. Recent activities carried out by Ansaldo Nucleare for the Ignitor program include the structural analysis of the machine Load Assembly for two new scenarios that extend the operation of the machine to H-regimes, where the plasma equilibrium configuration is of the double X-point type and the out-of-plane forces increase. A complete structural analysis was carried out for three scenarios with $B_T = 13$ T and $I_p = 9$ and 10 MA and double X points just outside the plasma chamber, and $I_p = 9$ MA and double X points just inside the plasma chamber. The lowered values of the plasma

current can offset the increase of stress due to the less favorable X-point configuration relative to the ‘extended limiter’ configuration.

The design of the cryogenic plant that uses gaseous helium as coolant has been verified by Linde Kryotechnik AG. After a pulse at the most extreme machine parameters, limited regions of the toroidal field coils reach temperatures up to 230 K and the central solenoid coils approach 220 K, while the vertical field coils remain under 100 K. Several hours are needed to re-cool the machine down to 30 K before each pulse. New calculations have verified that the plant cooling performance at reduced parameters allows operation with repetition rates of the order of one hour. Nonetheless, a review of the toroidal field coil cooling channels design has been undertaken, since this is the limiting factor for the achievement of higher pulse repetition rates.

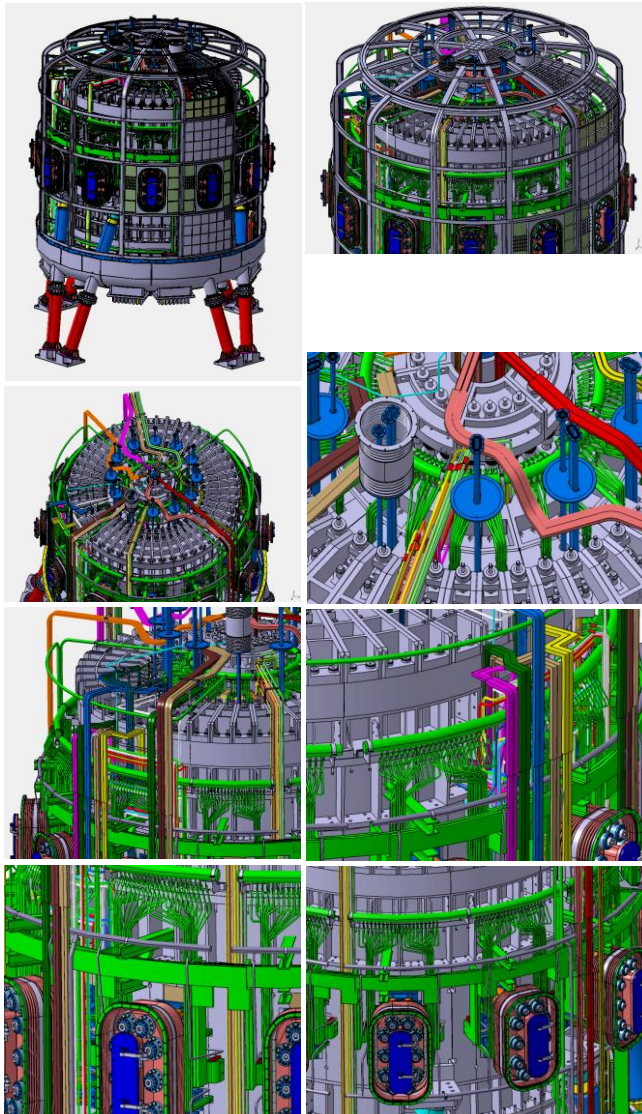

Fig. 6. Load Assembly (3D CATIA Model)

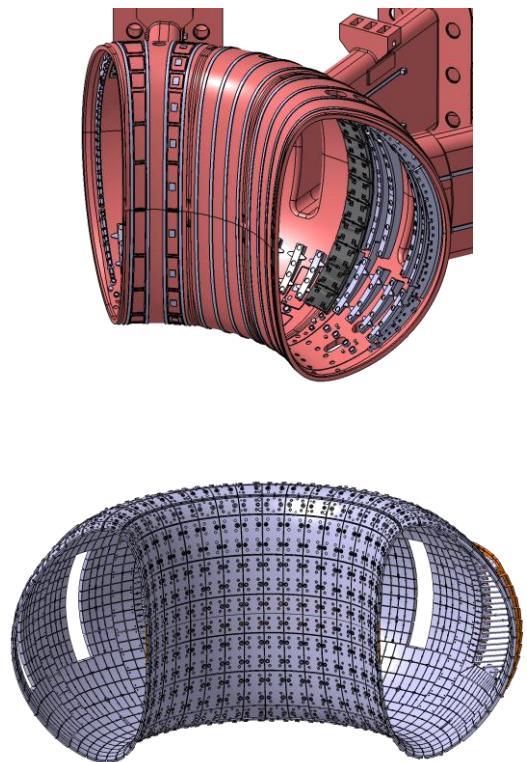

Fig. 8. First Wall arrangement in the Vacuum Vessel Outboard region and 180° First Wall structure.

7. Considered Developments

The advances made in the field of superconducting materials have led us to consider the possibility to design high field machines of the Ignitor type that employ hybrid magnets in order to obtain longer plasma pulses and higher repetition rates. Facilities involving a set of

machines operating with alternating cycles are contemplated, (considering that, for fusion burning plasmas a current drive system capable of sustaining steady state discharges cannot be envisioned at this time). An objective that can be pursued is that of devising reliable high flux sources of high energy neutrons for material testing with burning plasmas having peak densities close to those considered for Ignitor as DT fusion creates more neutrons per energy released than traditional neutron sources, such as fission or spallation. Clearly, in order to have a usable neutron source, a special kind of machine has to be conceived, with the space to house the materials to be tested within the toroidal magnet cavity between the plasma chamber and the toroidal magnet. Material samples to be tested should receive annual doses in the range of 20 dpa. At the same time, machine components close to the plasma must survive exposure to the neutrons. We have assumed the neutron energy spectrum expected at the Ignitor first wall. The total neutron flux on the first wall for each neutron produced in the plasma, is about 3.3×10^{-5} n/cm² s at the outer board midplane. At maximum performance, for 50/50 DT discharges, the neutron production in Ignitor is 3.3×10^{19} n/s. To compute material damage on pure Iron target replacing the first wall, the most recent, multi-group dpa cross section data base has been obtained by the NEA Data Bank. The dpa rate is estimated to be of the order of 3×10^{-26} dpa/n, consistent with evaluations found in the literature for Fe in other fusion devices. Similar results are obtained for other materials of interest. For comparison, the IFMIF neutron source and irradiation device envisions a high-irradiation volume of about 0.5 l, with damages of about 20 dpa/y for pure Iron. To obtain the same irradiation performance, with an irradiation volume of about 1000 l, an Ignitor-based device should produce approximately 6×10^{26} neutrons per year. If the neutron production rate could be increased up to 10^{20} n/s, a yearly damage rate of 20 dpa could be achieved with a duty cycle of about 20%.

8. Pellet Injection System

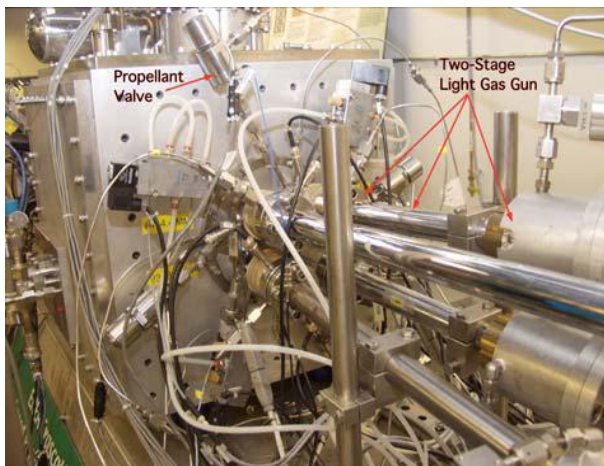

Fig. 9. The new arrangement accommodating both single- and two-stage guns on each barrel.

In order to control the density profile during the initial current rise phase of the discharge, which is critical for optimizing the Ohmic and fusion heating rates, a fast pellet injector, the Ignitor Pellet Injector (IPI) has been developed in collaboration between ENEA and ORNL [13]. The injector is designed to launch solid deuterium pellets in the 1.9 – 4.4 mm size range at speeds of 3 to 4 km/s, and features two innovative concepts: (i) the proper shaping of the propellant pressure pulse to improve pellet acceleration, and (ii) the use of fast closing (< 10 ms) valves to drastically reduce the expansion volumes of the propellant gas removal system. Two independent sub-systems have been built separately by the two teams and integrated at ORNL. Preliminary tests demonstrated that the two systems match properly, while their respective control systems interface correctly and perform outstandingly. The cryostat is actively cooled by a pulse tube refrigerator, but it has also been equipped with supplemental cooling from a liquid helium dewar. A first attempt to demonstrate reliable operation of the injector at relatively high speed (in the 2 to 3 km/s range) resulted in accelerating intact pellets at up to 2.2 km/s. Above 2 km/s, pellets trajectories were exhibiting a too wide dispersion, most likely due to the oscillation of the thin walled barrels, caused by the propellant shockwave propagating along them. The barrels have been replaced with thicker

ones, which can be more firmly held along their length to grant better alignment and stability. High speed tests of the injector in this new configuration have been carried for a two week experimental campaign carried out at ORNL, in April 2010. The impact patterns on the metal target show that the new barrel assembly effectively reduces the dispersion of pellets trajectories, though the injector alignment still needs some minor adjustments. The ENEA team had also developed a new arrangement that accommodates both a two stage gun and a standard propellant valve on each barrel (Fig. 9). A check valve protects the propellant valve against the hot, high peak pressure pulses produced when firing the two-stage guns. No failure was recorded over about 200 shots performed alternating single- and two-stage gun operation. With this configuration the operator can switch easily between standard and high-speed operation on any or all gun barrels. Yet, it was still more difficult than expected to preserve pellet integrity at velocities above 2 km/s. The analysis of in-flight pictures shows that, at moderate speeds, the pellets usually travel with their axis roughly parallel to their trajectories. As the speed increases, pellets are often observed to tilt, while their trajectories seem to drift somewhat out of the mid plane, probably striking against the side wall of the narrow (i.d. \sim 9.5 mm) channel that guides them through the photographic station and the mass probe. Our simulations indicate that, in order to achieve a 65% increase in pellet speed (from 1.82 to 3.0 km/s), an increase of the base pressure at the gun muzzle by a factor of about 3 (from 15.9 to 46.6 bar) is necessary, suggesting that the diameter of the conduit inside the diagnostics needs to be enlarged as much as possible.

9. Siting and Operation of Ignitor. The Trinita Facility

The environmental impact assessments for the Caorso site were carried out with the code GENII 2.0. The code, developed for the Environmental Protection Agency at the Pacific Northwest National Laboratory, incorporates the latest models and dosimetric ICRP risk factors in Federal Guidance Report 13.

To complete the assessment of the environmental impact in accident condition, the worst Design Basis Accident (DBA) was assumed. Accidents occurring less than 10^{-7} events/year were initially considered in the probabilistic analysis but found immaterial for radiological impact purposes, as the device will operate only few hours over ten years.

According to its design, the Ignitor machine requires a maximum plasma current of 10-11 MA and appropriate magnetic fields produced by a set of poloidal and toroidal field coils. The currents are generated and controlled by a system of AC/DC converters. Ignitor is made of mutually coupled circuits where the currents are imposed by the considered plasma equilibrium configurations. The design of Ignitor's pulsed power supply system (PPS) is based on having a line connected to a sufficiently powerful 400 kV network node. The maximum active power absorption is below $P_t \sim 850$ MW for a small time interval, and the maximum reactive power absorption is below $Q_c \sim 550$ MVar (already compensated by Static Var Compensator local).

In 2003 the manager of the Italian national network made a simulation to assess the sustainability of the network transients induced by the Ignitor pulse operation. This simulation was performed using the code SIRCE and on the basis of a pessimistic load diagram of Ignitor (maximum active power absorption of 1095 MW; maximum reactive power of 860 MVar). The results of the simulation were found acceptable. A new and improved analysis has produced a load chart with active power consumption lower than 850 MW and a reactive power consumption lower than 550 MVar. This implies a substantial improvement in

network response, suggesting that a reassessment of the behavior of the network will be successful.

The safety assessments show that the environmental impact associated with Ignitor's operation complies with all existing regulations. Doses in case of the worst accidental sequence are below any relevant limit for emergency countermeasures. Routine emissions and consequent doses are so low that tall stacks for airborne release dispersion are not necessary. The analysis carried out for Caorso and its connection to the power grid are now applied to the Troitzk site.

10. Tritium Laboratory Studies

The total Tritium inventory for the Ignitor facility is about 3 g and the Trinita site is licensed for 5 g. Given the large time interval (≈ 5 hours) between plasma discharges with the peak parameters and the relatively limited volume of the plasma column and chamber, the estimated amounts of the tritium to be injected are very small. The plasma exhaust is to be recovered in gaseous form avoiding oxidation and formation of hazardous tritiated water. Palladium membranes are used to separate the Hydrogen isotopes which are then stored in metallic getters. The results of the design of the Tritium Laboratory are given in Ref. [15], where the main components of it are described and the operations needed to supply the D-T mixtures to the plasma chamber and to recover the plasma exhaust are identified.

11. X-ray GEM Detectors for Burning Plasma Experiments

The harsh environment and higher values of plasma parameters to be expected in future burning plasma experiments (and even more so in future power producing fusion reactors) is prompting the development of new, advanced diagnostic systems. The detection of radiation emitted by the plasma in the X-ray spectral region can be detected by means of GEM gas detectors, developed at CERN as the natural evolution of Multiwire Proportional Chambers, with a number of advantages: higher counting rates, lower noise, good energy resolution, low sensitivity to background radiation [16]. GEM's can be used in several different ways, but two specific applications are being explored in the framework of the Ignitor program, one for plasma position control and the other for high resolution spectroscopy. The diagnostic layout on the Ignitor machine is such that the detectors will not be in direct view of the plasma, at locations where they can be efficiently screened by the background radiation. Prototype detectors $10 \times 10 \text{ cm}^2$ in area have been assembled and are being tested to assess the optimal geometrical parameters and operating conditions, regarding in particular the choice between Single and Triple GEM configurations, the gas mixture, and the problem of fan-out associated with the high number of output channels required for high resolution crystal spectrometers.

12. Plasma Control Studies

An integrated system for the vertical stability, shape and plasma current control exploiting a suitable decoupling scheme of all the circuits has been designed for the Ignitor machine. It assumes that a set of measurements is available giving the distances of the plasma boundary from reference points (gaps) at several position along the poloidal boundary, and that the values of the plasma current I_p and the poloidal field currents I_{PF_n} are available. The gap diagnostics have been modelled with a time delay of 2 ms. The vertical controller, acting on a faster scale, is included in the system together with the linear model of the plasma, passive structures and circuits. In particular, this controller drives in voltage the circuits for the vertical stabilization, therefore it is

not necessary to introduce additional controllers for the currents of the vertical stabilization circuits. The new design of the shape controller, shown in Fig. 10, is based on the same methodology used for the eXtreme Shape Controller (XSC) at JET [17]: using all the circuits for the shape control with the exception of those used to control the vertical stability has proved the capability to control up to four independent linear combinations of the 36 plasma-wall gaps. It is assumed that these gaps are made available by means of a numerical code for the identification of the plasma boundary from a set of magnetic or non-magnetic measurements. The selection of the circuits to be used for the shape control was made on the basis of an ordering of all the circuits with respect to the effectiveness in restoring the nominal shape after a realistic disturbance. Obviously, the circuits for the control of the vertical stability have been excluded in this analysis.

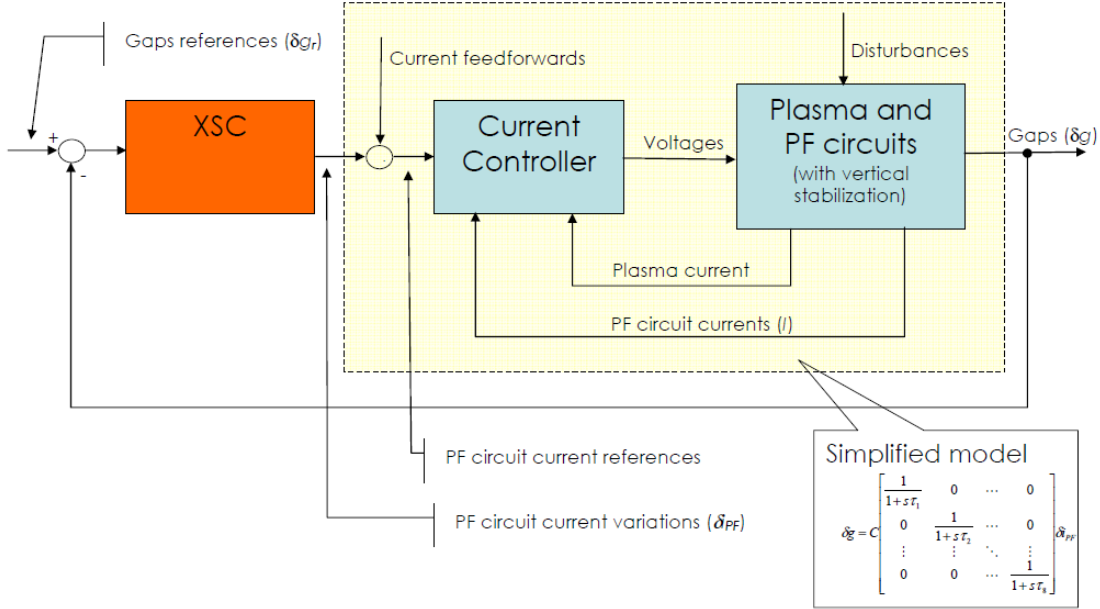

Fig. 10. Shape controller layout.

The integrated system performance has been assessed by means of the CREATE_L linearized model of plasma response [18] against a set of disturbances (sudden Vertical Displacement Event of 5 mm, instantaneous poloidal beta variation $\Delta\beta_{pol} = -0.1$, instantaneous variation $\Delta\ell_i = +0.1$) for two high performance plasma equilibrium configurations: the reference 11 MA plasma current limiter configuration and the 10 MA plasma current Double Nul configuration. The results point out satisfactory performances and a substantial shape recovery improvement, especially in the

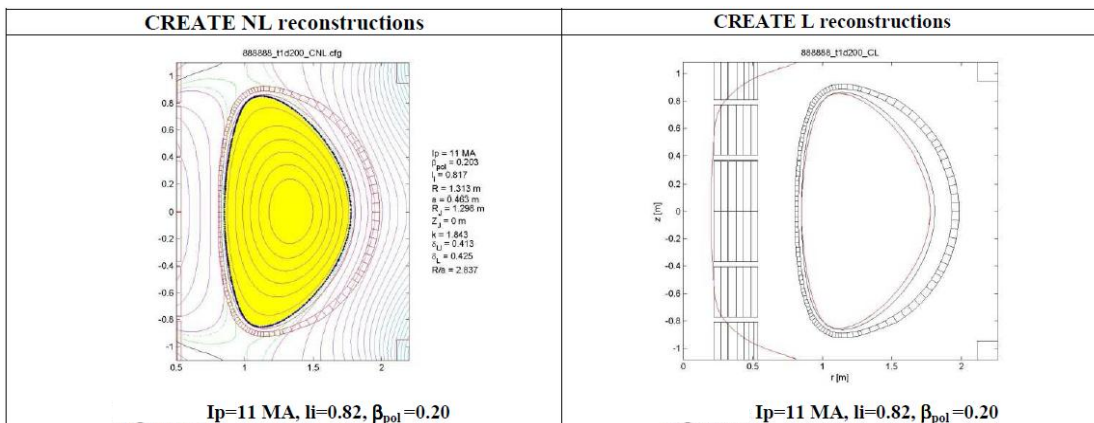

Figure 11. CREATE-NL and CREATE-L reconstructions of the Ignitor 11 MA plasma equilibrium.

presence of a disturbance in ℓ_i , with respect to the previous design where the plasma current controller was not present, the mutual interactions among different controllers were neglected and a simplified shape controller was adopted. This improvement has been obtained at the price of the presence of control currents in almost all the coils. The proposed shape controller guarantees robust performances in terms of maximum gap displacement and recovery time with respect to an increase of the diagnostics time delay from 2 ms to 5 ms.

The new shape controller can also be used to generate automatically the time evolution of the Poloidal Field Coil currents required to obtain new plasma configurations in the proximity of a given equilibrium, allowing moving to a new shape through a succession of equilibrium configurations. The desired configuration is specified to the shape controller as a set of step references on the various gaps. The reference IGNITOR 11 MA equilibrium obtained using CREATE-NL and CREATE-L model are shown in Fig. 11.

13. Ignitor Program Website Re-Development

To increase availability of information for both the scientific community and the general public, the current website (<http://www2.lns.mit.edu/ignitorproject/index.html>) is being redesigned. This maintains the same organizational information (collaborators, contacts, experimental information) as well as press release section with updates on the progress of the program. The main change is the designation of sections for physicists, engineers, and general public directly from the home page.

*Sponsored in part by ENEA of Italy and by the U.S. Department of Energy.

References

1. COPPI, B., AIROLDI, A., BOMBARDA, F., *et al.*, *Nucl. Fus.* **41(9)** (2001) 1253.
2. COPPI, B., AIROLDI, A., ALBANESE, R., *et al.* Paper FT/P3-23, 22nd IAEA Fus. En. Conf. (Publ. IAEA, Vienna, 2009).
3. MARMAR E., LIPSCHULTZ B., DOMINGUEZ, A., *et al.* *Bull. Am. Phys. Soc.* **45** (2009) 97.
4. WHYTE, D.G., HUBBARD, A.E., HUGHES, J.W., *et al.*, *Nucl. Fus.* **50** 105005 (2010).
5. B. COPPI and T.C. ZHOU, M.I.T. LNS Report 09/04 submitted to 2010 IAEA Fus. En. Conf.
6. B. COPPI *Nucl. Fusion* **42** (2002) 1-4.
7. SNIPES, J.A. and the International H mode Threshold Database Working Group, *Plasma Phys. Contr. Fusion* **42** (2000), A299.
8. MCDONALD, D. *et al.*, *Plasma Phys. Contr. Fusion* **48** (2006) A349.
9. MARTIN, Y.R., TAKIZUKA, T. and the ITPA H mode Threshold Database Working Group, *Journal of Physics: Conference Series* **123** (2008), 012033.
10. COPPI, B. and TANG, W., *Phys. Fluids* **31**, 2683 (1988).
11. CARDINALI, A. and COPPI, B., *Bull. of Am. Phys. Soc.* **54**, (N° 15) 73 (2009).
12. CARDINALI, A., E.N.E.A. Report RT/2009/37/FUS (2009).
13. FRATTOLILLO A. *et al.*, 23rd IEEE/NPSS SOFE, San Diego (CA), June 1-5 (2009) SP4A-14
14. COPPI, B., FAELLI, G. and ZUCCHETTI, M., M.I.T. LNS Report 09/04 (2009).
15. RIZZELLO, C. and TOSTI, F., *Fus. Eng. & Des.* **83** (2008) 594.
16. PACELLA, D., BELLAZINI, R., *et al.*, *Nucl Instr. Meth.* **A508(3)** (2003) 414.
17. AMBROSINO, G., ARIOLA, M., *et al.*, *Fus. Eng. & Des.* **66-68** (2003) 797.
18. ALBANESE, R. and VILLONE, F., *Nucl. Fus.* **38** (1998) 723.