



POLITECNICO DI TORINO  
Repository ISTITUZIONALE

Procedures for realistic models of fibrous gas filtration media

*Original*

Procedures for realistic models of fibrous gas filtration media / Tronville, P.; Rivers, R.. - ELETTRONICO. - (2014).  
((Intervento presentato al convegno Aerosol Technology 2014 tenutosi a Karlsruhe (Germania) nel 16-18 June 2014.

*Availability:*

This version is available at: 11583/2606190 since:

*Publisher:*

Association for Aerosol Research

*Published*

DOI:

*Terms of use:*

openAccess

This article is made available under terms and conditions as specified in the corresponding bibliographic description in the repository

*Publisher copyright*

(Article begins on next page)

## Comparison of measurement and simulation of particle deposition at charged microfibers

A. Hellmann, K. Schmidt, M. Pitz, S. Ripperger

Chair of Particle Process Engineering, Kaiserslautern University of Technology, 67663, Kaiserslautern, Rhineland-Palatinate, Germany

Keywords: Filtration, Simulation, Particle Deposition, Electrical effects.

In the field of aerosol filtration, electrostatic effects are relatively unexplored but absolutely decisive in many applications (Rengasamy, 2009). It is possible to adjust and improve the particle deposition for synthetic filter materials to increase the initial filtration efficiency. E.g. it is used in respiratory protective devices, cabin air filters or air conditioning systems. The measurement and simulation techniques for electrostatic forces respectively charges still need to be investigated.

To determine the influence of the charged fibres for the filtration efficiency three different methods can be obtained, measurements, empirical formula and 3D modeling. The general setup for the experiments is shown in figure 1.

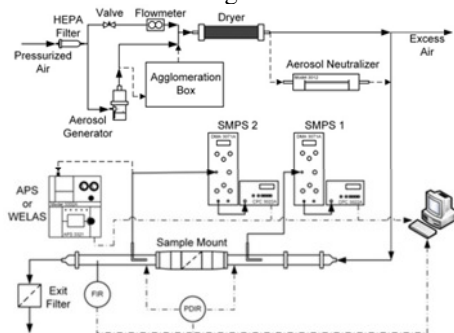

Figure 1. Scheme of the experimental setup.

The filtration efficiency experiments have been carried out with a sodium chloride aerosol. In order to quantify the influence of the electric effect the electret fibers were tested with and without charges. Hence, a suitable 3D model has been generated to simulate and compare the filtration experiment which is shown in figure 2.

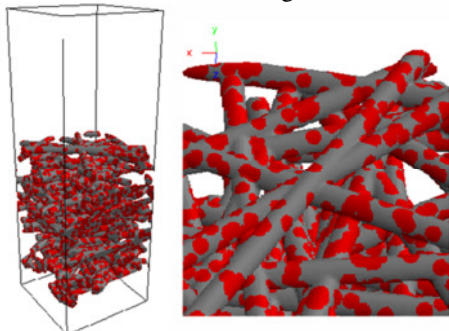

Figure 2. 3D model of microfibers with random spotted charged areas on the fibers surface.

In this work measurements and simulations have been performed and compared. Usage of empirical formulas considers not an adequate result for charged fibers. On the other hand the 3D simulation allows a good fit with the measured results of the filtration efficiency of charged fibers as shown in figure 3.

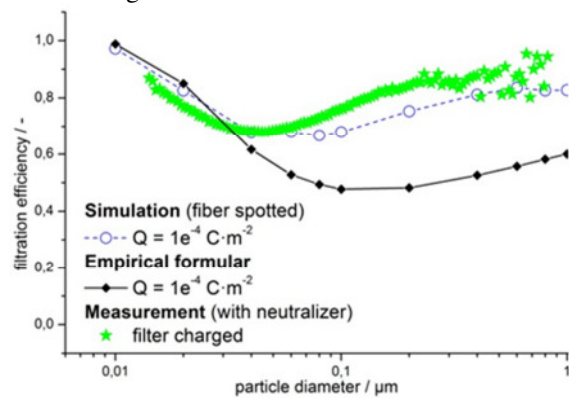

Figure 3. Comparison of measured and simulated filtration efficiencies.

- Rengasamy, S., Eimer B. and Shaffer R., *Comparison of Nanoparticle Filtration Performance of NIOSH-approved and CE-Marked Particulate Filtering Facepiece Respirators*, Ann. Occup. Hyg., Vol. 53, No. 2, pp. 117–128, 2009
- Schmidt, K., Hellmann, A., Pitz, M., Ripperger, S., *Modeling of NaCl aerosol deposition at electrically charged microfibers: FILTECH 2013*, Proceedings, Wiesbaden, 2013
- Schmidt, K., Rief, S., Wiegmann, A., Ripperger, S., *Microstructure Modeling and Simulation of Nanoparticle Deposition*, World Congress on Particle Technology 6, Nürnberg, 2010

## New models for the collision probability of particles onto bare model fibers in parallel arrays

T.K. Müller<sup>1</sup>, J. Meyer<sup>1</sup>, G. Kasper<sup>1</sup>

<sup>1</sup>Institute of Mechanical Process Engineering and Mechanics, Karlsruhe Institute of Technology, 76131 Karlsruhe, Germany

Keywords: Fibrous media, CFD, Particle Deposition

Inertial deposition (with concurrent interception) is the dominant and highly relevant deposition mechanism in air filtration of coarse particles ( $\gg 1 \mu\text{m}$ ) and/or at high filtration velocities. Despite many years of research and the availability of quite a few, mostly empirical expressions for inertial collision and adhesion probabilities, the available models are far from reliable, and discrepancies with accurate measurements remain to be explained (e.g. Kasper et al. 2010 [1]).

We have therefore calculated the collection efficiency  $\varphi$  of fibers positioned in a single layer of parallel fibers over a wide range of all relevant parameters (Stokes number  $St$ , Reynolds number  $Re$ , dimensionless fiber distance  $s/d_F$  and interception parameter  $R = d_p/d_F$ ).

Analytical flow fields were used in the Stokes flow regime ( $Re \rightarrow 0$ , Miyagi 1958), whereas CFD was employed in order to cover the technically relevant range of  $Re \leq 10$ . Using the resulting data base we have developed new and simple empirical laws for the impaction probability, which are expressed as functions of a modified Stokes number. This modified Stokes number allows for the quantification of the influence of neighboring fibers and fluid inertia.

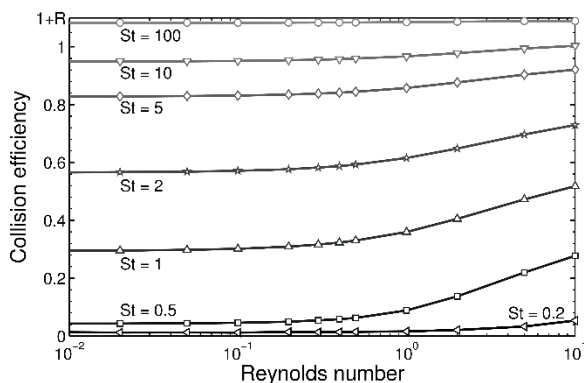

Figure 1. Collision efficiency vs. Reynolds number for various Stokes numbers at  $R = 0.1$  and  $d_F/s = 0.2$ .

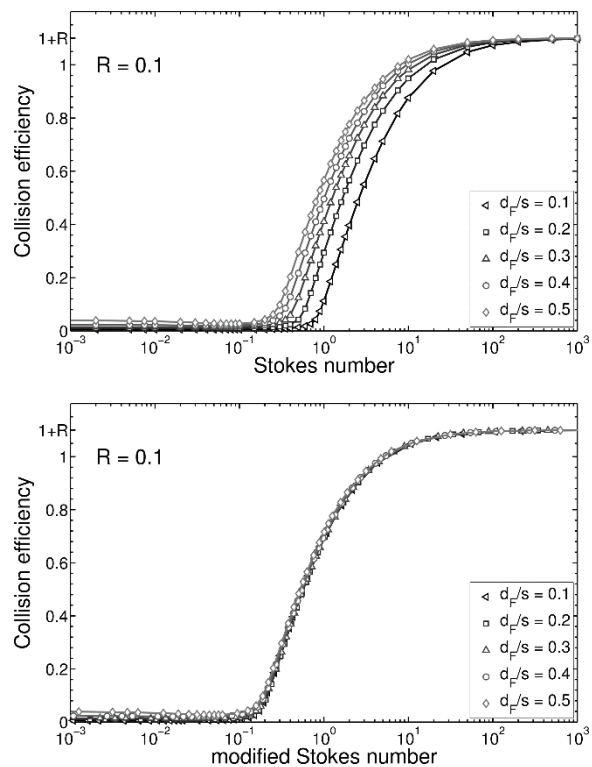

Figure 2. Collision efficiency vs. Stokes number (top) and vs. the modified Stokes number (bottom) for various fiber offsets at  $R = 0.1$  and infinitesimal  $Re$ .

Kasper, G., Schollmeier, S., Meyer, J., Hoferer, J. (2009). "The collection efficiency of a particle-loaded single filter fiber." *Journal of Aerosol Science*, **40**(12): 993-1009.

Miyagi, T. (1958). "Viscous Flow at Low Reynolds Numbers past an Infinite Row of Equal Circular Cylinders." *Journal of the Physical Society of Japan*, **13**(5): 493-496.

## Improvements in simulations of aerosol filtration in pleated filters taking into account the in-depth filtration

Nathalie Bardin-Monnier<sup>1,2</sup>, Liping Cheng<sup>3,4</sup>, Pierre-Colin Gervais<sup>1,2</sup>, Ralf Kirsch<sup>4</sup>, Andreas Wiegmann<sup>3</sup>, and Dominique Thomas<sup>1,2</sup>

<sup>1</sup> Université de Lorraine, LRGP, UMR 7274, Nancy, F-54000, France

<sup>2</sup> CNRS, LRGP, UMR 7274, Nancy, F-54000, France

<sup>3</sup> Math2Markt GmbH, Trippstadter Str. 110, 67663 Kaiserslautern, Germany

<sup>4</sup> Fraunhofer Institute for Industrial Mathematics, 67663, Kaiserslautern, Germany

Keywords: aerosol filtration, pleated filter, depth filtration, simulation.

Pleated filters are widely used in many industrial applications in air treatments due to their high effective surface area for a low overall dimension. Experimentally, Del Fabbro et al. (2002) observed that pleated filter pressure drop evolution with solid particles could be described by 3 periods. Among these is a period of depth filtration when particles are mostly collected within the fibrous medium. A quite innovative method is implemented in GeoDict in order to characterize the depth filtration in a pleat. It is characterized by the combination of flow and trajectory calculations in GeoDict and particle-media interactions simulations thanks to a MatLab routine.

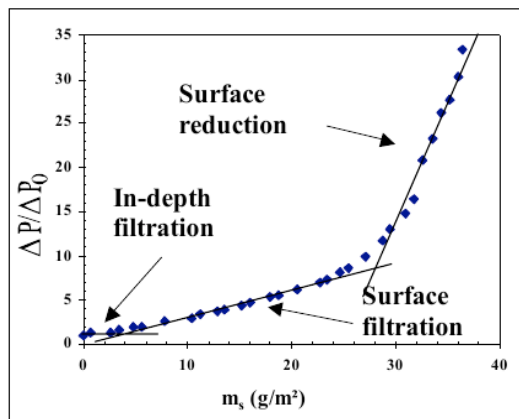

Figure 1. Phases of pleated filter clogging

The flow field is computed by solving Stokes-Brinkman equations with periodic boundary conditions. Each voxel of the domain is characterized by its porosity and permeability. Once the flow is established, particles are launched in the domain and their motion is calculated thanks to a force balance taking into account drag effects, Brownian diffusion and electrostatic effects. The travel paths inside the media are known and Matlab allows determining the interactions inside the media thanks to a flexible capture probability model.

The particle deposition inside the media induces changes in voxel porosity and permeability. Based on these new properties, the flow is computed again. Loops can be simulated until the desired number of batches is reached.

The first results with a simplified capture probability model (constant probability) that have been obtained are quite encouraging. A good agreement is found for the evolution of the overall pressure drop across the filter element (Fig. 2).

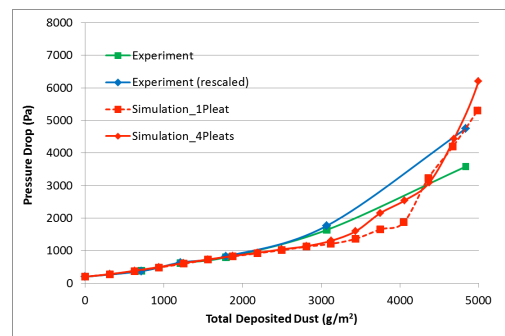

Figure 2. Experimental/Simulated pressure drop during clogging

Except the top and bottom of the pleat, the deposition distribution of particles from the simulation is in the reasonable range compared to the data available in the literature (Gervais, 2013). However, the simulation had more particles deposited.

At present, the attention is focused on the development of capture probability models in which the influence of the fibre type, the velocity and particle diameter are taken into account.

Del Fabbro, L., (2002). *Filt. Sep.*, 39(1) :35-40

Gervais, P.C., (2013). PhD Thesis Université de Lorraine

## A simplified model for the simulation of the loading process in pleated filter elements

Florian Keller<sup>1</sup>, Sebastian Brocke<sup>1</sup>, Andreas Beck<sup>1</sup>, Martin J. Lehmann<sup>1</sup>

<sup>1</sup>MANN+HUMMEL GMBH, 71638 Ludwigsburg, Germany

Keywords: Loading kinetics, resolved pleats, simulation, ANSYS FLUENT.

### 1. Introduction

In automotive applications, pleated filter elements are commonly used for protecting the engine by cleaning of engine oil, fuel and intake air (Durst et al., 2007). A preferred way to rank a filter medium is by the evolution of the pressure drop over the collected mass. Besides the performance of the filter medium a key factor is the flow and local particle size distribution on the dirt side of the filter medium.

Simulation methods are used for better understanding of the loading kinetics of filter element and to serve as a base for further optimization. Thereby, for a virtual product development numerical simulations have to be fast and reliable. Due to the different length scales in filter elements – ranging from the scale of the fibers in the filter media to the dimensions of the housing – it is not possible to simulate all geometrical details. Thus, in the past the bellow of the filter element was modelled as a homogenous porous block without resolving the geometry of the pleats, see e.g. Huurdeman and Banzhaf (2006).

Recently, Hettkamp et al. (2012) showed the correlation between the pressure drop and the dust loading for perfect U- and V-shaped pleats. This offers a new way for a simplified model of the filter element to enhance simulation of its loading kinetics.

### 2. Methodology

In this contribution we focus on fast and enhanced simulation of the loading kinetics of pleated media. The filter bellow is modeled as porous block but in a sub-model the detailed loading of a single pleat is accounted for. We extend the work of Hettkamp et al. (2012) to a more general class of pleats which differ from the ideal shapes due to manufacturing reasons. As in Hettkamp et al. (2012) it is assumed that dust is distributed evenly along the filter media of the pleats, i.e. no separation based on inertia on the pleat scale. But on the macro scale inertia is taken into account and particles can be uneven distributed on the surface of the filter bellow. As pleat clogging is a major factor for the increase of the pressure drop, we limited ourselves for this study to cake filtration.

The CFD simulations are carried out with the software ANSYS FLUENT which has been extended by using UDFs. To enhance the computational time which is needed for efficient simulations, parcels are used instead of particles.

### 3. Results

The simulation results are compared and validated by experiments using ISO fine dust. Figure 1 shows the evolution of the pressure drop increase over the deposited mass for simulation (dots) and experiments (line). The simulation is carried out for a bellow in a channel flow with homogenous inflow. A good correlation between experiments and simulations is obtained with the enhanced sub-model for loading kinetics of pleated media.

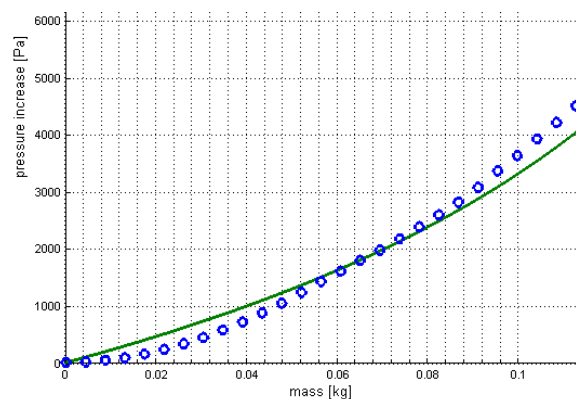

Figure 1. Comparison between simulation (dots) and experiments (line) of the pressure drop increase of a rectangular filter element under homogenous flow conditions.

### 4. References

- Durst, M., Klein, G.-M., Moser, N. & Trautmann, P., 2007. Filtration und Separation in der Automobiltechnik. Chemie Ingenieur Technik, 11, 79(11)
- Huurdeman, B. & Banzhaf, H. (2006). CFD Simulation of Flow in Air Cleaner with Transient Dust Loading of the Filter Element. SAE World Congress.
- Hettkamp, P. & Kasper, G. (2012). Simulation of Pressure Drop and Capacity for Pleated Air Filters Loaded with Dust, Filtration Journal, Vol. 12 (3), pp 183-192.

## Air flow and particle transport simulations in fibrous media

P.C. Gervais and L. Ricciardi

Institut de Radioprotection et de Sûreté Nucléaire (IRSN), PSN-RES/SCA/LEMAC,  
Saclay, 91192, Gif-sur-Yvette, France

Keywords: aerosol filtration, fibrous media, collection efficiency, GeoDict, experimental validation.

When it comes to aerosol filtration, fibrous media are so far the most efficient filters among the different devices. Since they are easy to use and maintain, they are widely used in areas related to air treatment such as nuclear containment. The main objective of our researches is to improve the knowledge on the performances of filters used in the nuclear industry to contain radioactive particles in normal operation or accident situation. The initial performances of such media are characterized by two important parameters: the filtration efficiency and the pressure drop. The air flow and particle transport modeling is hardly achievable due to the wide range of operating conditions and characteristics of aerosol and media. Numerical approaches, consisting in designing fibrous micro-geometries together with solving transport equations, seem to be relevant tools to investigate this problem even if they require an experimental validation step, which is discussed in this work.

To cover a wide range of geometric characteristics and especially the solid volume fraction  $\alpha$  and the filter thickness  $Z$ , experimental results from two types of fibrous media are compared to the simulations. Gougeon *et al.* (1996) provide spectral efficiencies for two monomodal media manufactured by Bernard Dumas (Bergerac, France). A Differential Mobility Analyser was used to select the precise diameter of a DEHS aerosol. The concentration was measured downstream and upstream of the filter with a continuous flow Condensation Nuclei Counter. The characteristics of both filters, made with glass fibers, are shown in Table 1.

Table 1. Characteristics of monomodal media

Ref.	$d$ ( $\mu\text{m}$ )	$\alpha$ (%)	$Z$ ( $\mu\text{m}$ )
110x475	2.7	9.87	300 $\pm$ 10
106x475	0.65	3.72	780 $\pm$ 20

Five bimodal media, which are blends of fine and coarse fibers (diameters  $d_f$  and  $d_c$  respectively) are also studied. The characteristics of these filters, made with polyethylene terephthalate (PET) fibers, are shown in Table 2.

Table 2. Characteristics of bimodal fibrous media and mass proportions ( $Y$ ) of fiber blends

Ref.	$d_f$ ( $\mu\text{m}$ )	$Y_f$ (%)	$d_c$ ( $\mu\text{m}$ )	$\alpha$ (%)	$Z$ ( $\mu\text{m}$ )
H	10.9	55	28.2	19.3	860 $\pm$ 20
I	10.9	10	28.2	17.7	1010 $\pm$ 30
J	10.9	15	28.2	18.3	930 $\pm$ 20
K	10.9	58	45.1	17.4	920 $\pm$ 20
L	10.9	23	45.1	13.8	1130 $\pm$ 20

They are manufactured by the GEMTEX laboratory (Roubaix, France). Efficiency measurements are currently in progress using a liquid monodispersed aerosol generator and a Scanning Mobility Particle Sizer.

Virtual 3-D microstructures are generated using GeoDict2013 ([www.geodict.com](http://www.geodict.com)). Simulation domains considered in this work are at least  $25k^{1/2} \times 25k^{1/2} \times Z$  where  $k$  is the experimental permeability. Inside the microstructure, each fiber is designed with an infinite cylinder length. The diameter of the fine fibers should be represented by at least 10 voxels. The fiber orientation is controlled. The airflow through the microstructure is governed by the Stokes and continuity equations. Filtration simulation is performed thanks to a Lagrangian description of the particle motion. Efficiency results from the balance between the upstream and downstream particle numbers. To be representative, averaged results obtained with microstructures generated using three random seeds as well as three particles initial positions are presented. The results are obtained using a cluster with 512 GB of RAM and a 4-hexa-core AMD CPU with a speed of 3.0 GHz.

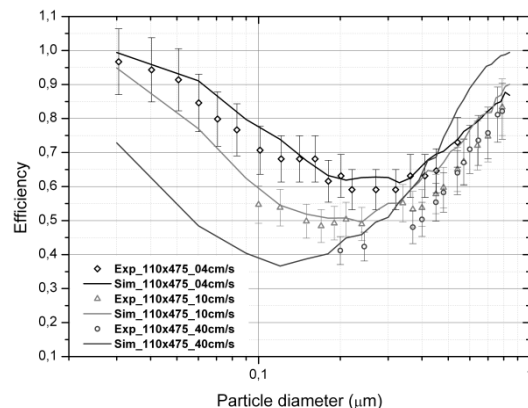

Figure 1. 110x475 filter experimental confrontation for 3 filtrations velocities.

The comparison between simulated and experimental data shows that GeoDict gives a quite good estimation of filtration efficiency in laminar flows, especially for low velocities. Parametric simulations are in progress in order to develop predictive models for efficiency as well as pressure drop and penetration profiles.

Gougeon, R., Boulaud, D. & Renoux, A. (1996). *Chem. Eng. Commun.*, 151, 19-39.

## Optical observation of a single pleat during loading

S. Bourrous\*<sup>1,2,3,4</sup>, P. Lemaître<sup>1</sup>, L. Bouilloux<sup>1</sup>, J.-C. Appert-Collin<sup>2,3</sup>, D. Thomas<sup>2,3</sup>, L. Tampère<sup>4</sup>

<sup>1</sup> Institut de Radioprotection et de Sûreté Nucléaire (IRSN), PSN-RES, SCA, Gif-sur-Yvette, 91192, France  
Soleiman.Bourrous@irsn.fr

<sup>2</sup> Université de Lorraine, LRGP, UMR 7274, Nancy, 54001 Nancy, France

<sup>3</sup> CNRS, LRGP, UMR 7274, Nancy, 54001 Nancy, France

<sup>4</sup> Camfil Farr, BP80225 Rte d'Avrigny, ZI de Saint Martin Longueau, 60722 Pont Sainte Maxence, France

Keywords: Filter, HEPA, Pleat, Optical measurement

In industrial facilities, HEPA pleated fibrous filters are widely used to ensure the air quality, by separating solid or liquid contamination. Most of the works concerning HEPA filtration are focused on their efficiency. This problematic is currently well known, especially for the MPPS. Nevertheless, clogging and pressure drop increase during loading remain an actual subject of interest.

Works about the clogging of pleated HEPA filters in their flow range of use ( $V_f < 2.5$  cm/s) mainly show that the air flow resistance for a given mass of particles collected increases faster for low velocities. For high filtration velocities, inertial deposition of particles has already been shown experimentally and computed (Del Fabbro *et al.* 2002, Rebai *et al.* 2010). Homogeneous deposition and the related surface reduction have also been studied experimentally and theoretically (Del Fabbro *et al.* 2002). But no convincing explanation has been brought to explain additional resistance increase at low velocities.

Previous works (Bourrous *et al.* 2013) have shown the homogeneity of the deposit for nanoparticles at low velocities in HEPA pleated filters. In the present work, the phenomenon occurring inside the pleat is optically observed using a shadowscopy measurement protocol. For this, a specific clogging test bench has been designed which allows the loading of a single filter pleat, with an optical access to observe the formation of the particle deposit. For all tests, airflow is fixed, pressure drop is monitored during the loading and mass is estimated by weighing the loaded filter in order to link a visual observation to a pressure drop curve. This is done for the following operating conditions (table 1).

Table 1. Aerosol used and filtration velocities

Aerosol type	Al <sub>2</sub> O <sub>3</sub>	C
Mean mobility diameter [nm]	950	42*
Filtration velocities (V <sub>f</sub> ) [cm/s]	0.2 - 2	0.2 - 2

\*Soot aggregates made from 7 nm primary particles

The first results of experiments performed with alumina particles show the effect of singularities in the medium like fibers broken during the pleating process (figure 1-a) which act like a priming and collect incoming particles (Figure 1-b). This leads to a surface reduction measurable on pressure drop evolution.

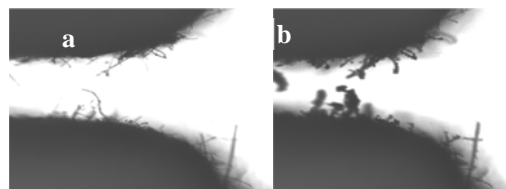

Figure 1. Picture of the pleat head of a clean (a) and loaded (b) filter using shadowscopy

So, obviously, velocity seems to play a role by destroying the structure formed in the pleat. For a low velocity, the size of the formed structures could lead to a pleat obstruction and induce a pressure drop gap. Higher velocity will not permit these structures to reach a sufficient size to influence the pressure drop evolution of the filter.

Particle size also has an important place by conditioning the single fiber collection efficiency and the cohesion of the formed arrangement and its porosity. These points will have a clear influence on the lifetime of the filter. Moreover, complex particles such as combustion particles (Mocho *et al.* 2009) combine the properties of both particles (specific surface and adhesion forces of the primary particles and behavior of thick particles in the air flow).

This kind of arrangement building has already been observed numerically for micron particles without any fibrous priming, (Rebai *et al.* 2010). These observations still have to be experimentally validated by a direct observation.

Mocho, V., Ouf, F.X., (2009) Clogging of industrial pleated high efficiency particulate air (HEPA) filter in the event of fire in a confined and ventilated facility. Filtech 2009, October 13-15 2009, Wiedsbaden, Germany.

Del Fabbro, L., Laborde, J.-C., Merlin, P., Ricciardi, L., (2002) Air flows and pressure drop modelling for different pleated industrial filters. *Filtration and Separation* 39, pp. 35-40.

Rebai, M., Prat, M., Meireles, M., Schmitz, P., Baclet R., (2010) A semi analytical model for gas flow in pleated filters. *Chemical Engineering Science* 65 (9), pp. 2835-2846.

Bourrous S., Bouilloux L., Ouf F.-X., Appert-Collin J.-C., Thomas D., Tampère L., Morele Y., (2013) Measurement of the nanoparticles distribution in flat and pleated filters during clogging. *Aerosol Science and Technology*, in press, corrected proof, 2013.

## Procedures for realistic models of fibrous gas filtration media

Paolo Tronville<sup>1</sup> and Richard D. Rivers<sup>2</sup>

<sup>1</sup>Department of Energy, Politecnico di Torino, Corso Duca degli Abruzzi 24, 10129, Turin, Italy

<sup>2</sup>EQS Inc., 1262 Bassett Avenue, 40204 Louisville, KY, USA

Keywords: fibrous media, filtration modeling, filtration performance, gas filter media, media compressibility.

The behavior of most HVAC system components has been quantified with accuracy sufficient to allow meaningful minimization of both economic and energy system costs. For one component - air filters - performance and cost predictions are still highly approximate, hence designers have difficulty including their contribution to capital, operating, and energy costs.

The first step in simulating the performance of an air filter system is to model the micro-scale geometry of the media in the chosen filter design so that the fluid flow can be calculated. Figure 1 is a SEM image of media from a typical building-ventilation air filter. It shows the chaotic structure of fibers and the polymer binders joining fibers. Binders often form impermeable webs which add significant obstructions to air flow.

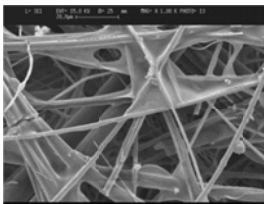

Figure 1. SEM image of a ventilation-grade air filter medium

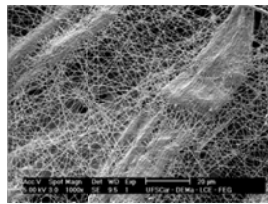

Figure 2. SEM image of a cellulosic medium with nanofiber web on its upstream face

Filter media sometimes have layered structures. Figure 2 is a SEM image of one, in which a nanofiber layer (the white mesh) has been deposited on the upstream face of a coarser-fibered cellulosic filter medium. A 3-dimension (3D) simulation of media inevitably has much simpler geometry than real media. We have chosen to use still simpler 2D geometries which mimic a cross-section of media. 2D allows us to explore the improvements in prediction accuracy obtained by better matches to the fiber size distributions in the SEM images, and to simulate binder webs more easily. The effects of particle bounce on impacting fibers, adhesion and dislodgement after contact can also be studied with shorter computer runs.

Our algorithm first defines the number of distinct layers in the medium, and the SEM images available for each layer. The user then extracts the fiber image width distribution, using an interactive technique. The distribution of these widths is always truncated (Figure 3), for filter media always have

minimum and maximum fiber sizes. The distribution is fitted with functions which model the truncations in its tails. The fit is then used to generate a table of fiber cross-sections, which are positioned randomly in the computational domain. The positioning of cross-sections stops when the following criterion is met:

$$\frac{[\Sigma \text{ cross-section areas}]}{[\text{domain media area}]} = \frac{[\text{measured fiber fractional solids}]}{[\text{media}]} \quad (1)$$

If the media has binder, this is simulated by randomly-positioned links with defined thickness and radius of curvature at points of contact with neighboring fibers, as shown in Figure 4 for round fibers. The cross-hatched zones in Figure 4 are the areas of the simulated binder for these three linked fibers. The creation of binder links stops when the sum of these areas meets the criterion (1), with binder fractional solids substituted for fiber solids fraction.

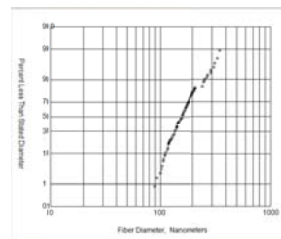

Figure 3. Program plot of truncated log-normal fiber distribution

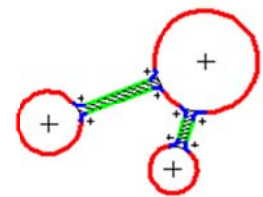

Figure 4. Binder simulation. Fiber arcs are red, binder arcs, blue; binder lines green; all arc centers +.

An algorithm defines the Knudsen Number for assemblages like that shown in Figure 4, so that slip effects can be implemented. Routines for incorporating media compression in CFD analyses are included.

A filter medium such as shown in Figure 2 requires special attention. We have modeled the cross-section of the cellulosic fibers by irregular polygons approximating their sections observed in SEM images like Figure 2. We measure the areas of the patches joining essentially round nanofiber links, and estimate the patch average thickness from the fibers each patch links. Both the widths and lengths of the nanofiber links are measured, allowing a reasonably accurate calculation of web volume.