



POLITECNICO DI TORINO
Repository ISTITUZIONALE

Improvement of the energy networks in a small town district

Original

Improvement of the energy networks in a small town district / L. Giaccone; F. Rozzo; A. Sozza; L. Spinolo; M. Tartaglia. - STAMPA. - (2008), pp. 1-6. ((Intervento presentato al convegno WESC 2008 tenutosi a IASI ROMANIA nel 29 GIUGNO 2 LUGLIO 2008.

Availability:

This version is available at: 11583/1906268 since:

Publisher:

Published

DOI:

Terms of use:

openAccess

This article is made available under terms and conditions as specified in the corresponding bibliographic description in the repository

Publisher copyright

(Article begins on next page)

IMPROVEMENT OF THE ENERGY NETWORKS IN A SMALL TOWN DISTRICT

L. Giaccone⁽¹⁾, F. Rozzo⁽²⁾, A. Sozza⁽³⁾, L. Spinolo⁽⁴⁾, M. Tartaglia⁽¹⁾
 (1) Dipartimento di Ingegneria Elettrica, Politecnico di Torino, Torino, Italy
 (2) Municipality of Torino, Torino, Italy
 (3) Gradenigo Hospital, Torino, Italy
 (4) GTT Gruppo Torinese Trasporti, Torino, Italy
 E-mail: luca.giaccone@polito.it

Abstract

Recent studies have shown that the primary energy consumption in the EU-25 has risen steadily doubling its value with reference to the year 1970. Current greenhouse gas emissions are still too high as clearly recognised in the Kyoto process. As a consequence of these energy developments, CO₂ emissions will rise significantly up to 2010 which is clearly incompatible with the EU's climate policy. Within this scenario it has been developed the idea of improving the energy use by introducing energy networks. It will be analyzed a district of Torino which includes an hospital called Gradenigo, a public primary school and a parking managed by the local transport utility.

A micro-grid will substitute the actual energy independent circuits making advantages of a suitable energy management. The new structure will be based on a polygeneration system. In particular a tri-generation plant and a Photovoltaic system will be installed. In this paper the energy consumption analysis of the existing systems will be given which is the base to design the proposed grid systems. Technical and economical design of the new network will be justified predicting the energetic and environmental balance in order to highlight the primary energy savings and the CO₂ reduction that the new technologies offers

Keywords: energy smart grid, trigeneration, photovoltaic installations, electric vehicles.

1. INTRODUCTION

Recent studies have shown that the primary energy consumption in the EU-25 has risen steadily doubling its value with reference to the year 1970 [1]. As a consequence of these energy developments, CO₂ emissions are expected to rise significantly up to 2010 which is clearly incompatible with the EU's climate policy. Within this scenario it has been developed the idea of improving the energy use by introducing energy networks. In this paper it will be analyzed a district which includes an hospital named Gradenigo, a public primary school and a parking managed by the local transport utility GTT.

The existing network is represented in Figure 1 and the energy needs of the users are summarized in Table 1.

Table 1 – Energy needs

	Hospital Gradenigo	Group of schools	Parking
Electricity	yes	yes	yes
Heating	yes	yes	no
Cooling	yes	no	no

A micro-grid will substitute the actual energy independent circuits making advantages of a suitable energy management, Figure 2. The new structure will be based on a polygeneration system. In particular a trigeneration plant (also known as Combined Heat and Cooling Power or CHCP) will be installed to produce electricity, heating and cooling mainly for the hospital.

The cogenerator (CHP, Combined Heat Power) will be coupled to the heating system of the hospital and to an absorption chiller in order to give a contribution to the cooling demand. Moreover PV modules will be installed in the district and connected in parallel to the existing low voltage network.

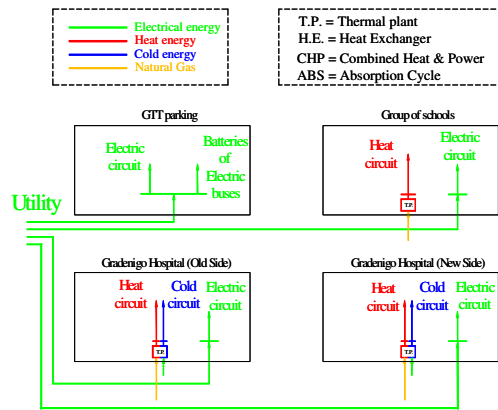

Figure 1 – Existing network

In this paper the energy consumption analysis of the existing systems will be given and this will be the base to design the proposed grid systems. Technical and economical design of the new network will be justified predicting the energetic and environmental balance in order to highlight the primary energy savings and the CO₂ reduction that the new technologies offers.

The environmental balance has been done using the emission factors referenced in [2, 3, 4] and listed here below:

- *ef_elt*: emission factor for separate production of electricity. The mentioned kWh correspond to the electrical energy produced
- *ef_th*: emission factor for separate production of heating. The mentioned kWh correspond to the thermal energy produced
- *ef_chp*: emission factor for combined production of electricity and heating. The mentioned kWh correspond to the CHP fuel

Table 2 – Emission factor

<i>ef_elt</i>	<i>ef_th</i>	<i>ef_chp</i>
kg CO ₂ /kWh	kg CO ₂ /kWh	kg CO ₂ /kWh
0.494	0.252	0.202

2. USER CONSUMPTION ANALYSIS

As a general rule suitable for every field, the benefit of a new development have to be defined with reference to a common base configuration. In this paper the base configuration is obtained evaluating the actual consumption of the users in the district.

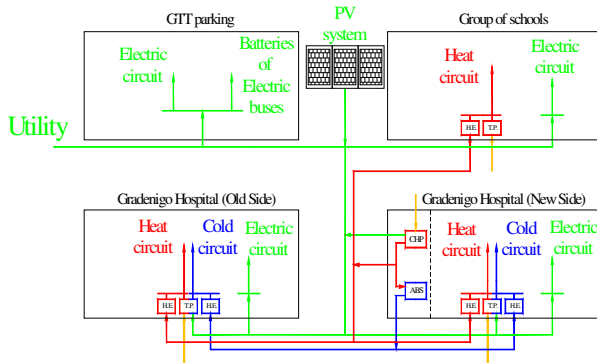

Figure 2 – Future network

The district user with higher consumption is the hospital, the schools have an intermediate consumption and finally we have the parking. Unfortunately some technical constraints make impossible (or not convenient) the installation of a new energy source in the schools. In fact in these building there is no space for the installation of a CHP/CHCP unit and the roofs are not oriented in a suitable direction for a PV system installation.

Therefore the CHCP unit will be installed in the existing thermal plant of the hospital and the PV system will be installed on the parking roof.

2.1 Gradenigo Hospital

Electricity consumption

The main building of the district is the hospital named Gradenigo. This is the user that requires a more detailed analysis because it needs at the same time energy for electricity, heating and cooling.

As frequently happen the most detailed data are available for the electricity consumption because big users, like hospitals, can buy electricity at prices defined with reference to the hourly bands. In this case the local utility installs an energy meter which stores the user load profile. Through the data downloaded from this meter it is possible to derive 2 typical days per month, one is representative for week days (Figure 3) and the other one for week-end days (Figure 4).

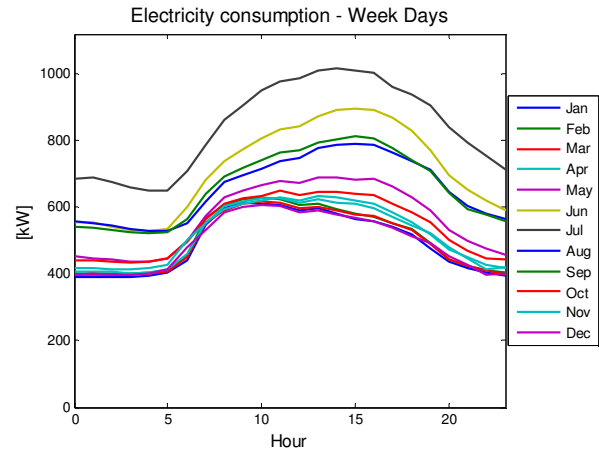

Figure 3 - Gradenigo Electricity load profiles - Week Days

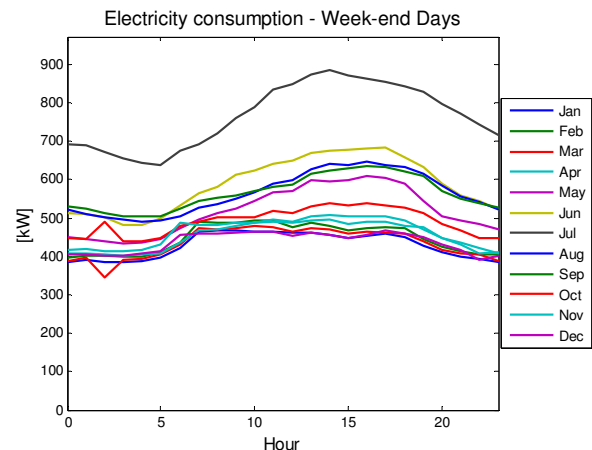

Figure 4 - Gradenigo Electricity load profiles - Week-end Days

The annual energy consumption for electricity is equal to 4925213 kWh_e.

Heating consumption

The evaluation of heating consumption has been done using the energy bills. This means that the thermal load profile are not directly available.

The evaluation of the Gradenigo thermal consumption during the day have been done using the load profile of another hospital in Rome called “Fondazione Santa Lucia”. The consumption of this hospital are taken from reference [5].

Using this notation:

- $P_{th-SL-j}$: “Fondazione Santa Lucia” thermal consumption in the hour j;
- P_{th-G-j} : “Gradenigo” thermal consumption in the hour j;
- $E_{th-SL-d}$: “Fondazione Santa Lucia” thermal consumption in the day d;
- E_{th-G-d} : “Gradenigo” thermal consumption in the day d;

the Gradenigo load profile are found by means of the following equation:

$$P_{th-G-j} = \frac{E_{th-G-d}}{E_{th-SL-d}} P_{th-SL-j} \quad \text{with } j=1, \dots, 24 \quad (1)$$

The load profile of “Fondazione Santa Lucia” have been reshaped in order to obtain the daily Gradenigo energy consumption achieving the result in Figure 5. Heating profiles are not divided in week or week-end days because they mainly depend on the external temperature and not on the day of the week.

The annual energy consumption for heating is equal to 8170334 kWh.

Cooling consumption

Cooling consumption are often hidden in the electrical one because cooling energy is, in most of the thermal plant, supplied from electrical chiller. Therefore cooling consumption are included in already included in the load profiles of Figure 3 and Figure 4.

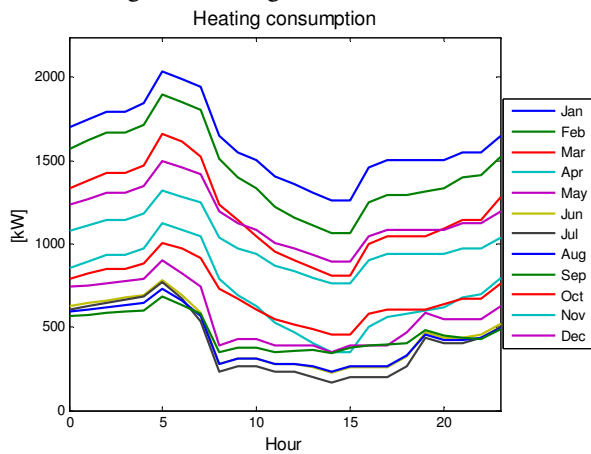

Figure 5 - Gradenigo Thermal load profiles

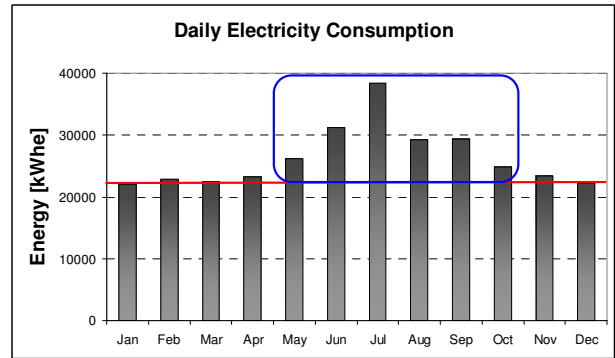

Figure 6 – Energy consumption for cooling demand

Cooling load profile have been evaluated by mean of energetic consideration. Figure 6 shown that in summer months the daily electricity consumption increase due to cooling demand. The amount of daily electrical energy corresponding to the cooling demand (E_{el-c}) can be used for deriving a simple cooling load profile defined by the average absorbed power cooling (P_c):

$$P_c = \frac{E_{el-c}}{h_c} COP_{CH} \quad (2)$$

where:

- h_c are the working hour of the cooling system (here supposed equal to 16)
- COP_c are the Coefficient Of Performance of the electric chiller (here supposed equal to 3)

Figure 7 shows the cooling profile (only for week days for the sake of brevity) obtained following this procedure. It has to be stressed that now the electricity load profiles in Figure 3 and Figure 4 have to be updated removing the cooling demand just calculated. The new electricity load profile are show in Figure 8.

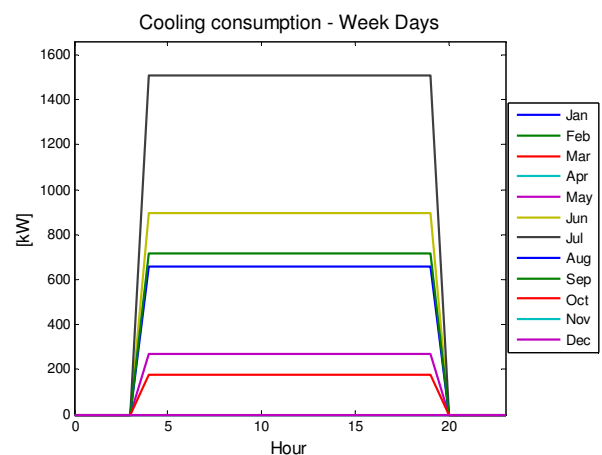

Figure 7 – Cooling load profiles – Week Days

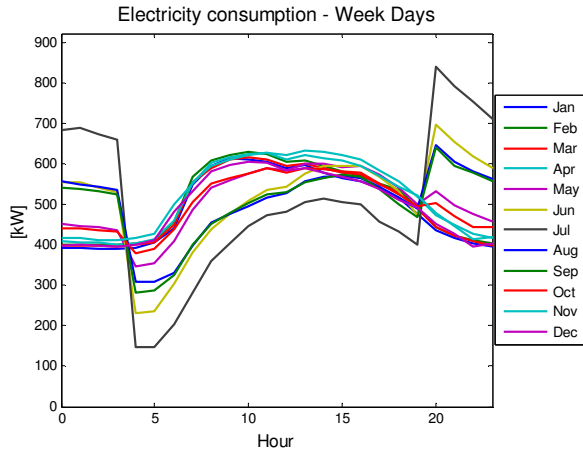

Figure 8 – Gradenigo Electricity load profiles without cooling demand

The annual energy consumption for cooling is equal to 2032400 kWh_c and the electricity consumption without the cooling demand is 4328100 kWh_e.

2.2 School

The total consumption in the school of the district are:

- 49416 kWh_e of electricity
- 604143 kWh_t for heating

The total consumption of the school is very low with respect to the hospital consumption, therefore the trigeneration system will be designed on the basis of the hospital energy demand.

2.3 Parking

The last important user is the parking of the district. It is managed by the local transport utility. From the point of view of the energy consumption it needs only electrical energy for the lighting system and for charging the electrical buses used for the public transport. The annual electricity consumption, evaluated by the electrical bills, is 400800 kWh. The charging activity is the lower part of this consumption, in fact one bus need 10 kWh of electricity for its charge, and during the day 8 buses are charged. The charging activity is done only during the week days of the year (about 260). Therefore the annual electricity consumption of the parking is:

$$260(\text{days}) \cdot 8(\text{buses}) \cdot 10(\text{kWh}) = 20800\text{kWh}$$

The energy demand for charging the electric buses is about the 5% of the total consumption.

3. CHCP PLANT PRELIMINARY DESIGN

The performance of the CHCP plant are tightly dependent from the user requirements. In other word the higher will be the utilization of the CHCP produced energy, the higher will be the investment profitability and the environmental benefit.

The user directly connected to the CHCP system is the hospital, therefore its load profiles (electricity, heating and cooling demand) have been used for simulating the best production system.

A CHCP system is composed by a cogenerator (CHP) thermally coupled with an absorption chiller (ABS). Starting from 11 different CHPs and 15 different ABSs all the possible combination have been analyzed for a total of 176 configuration (also the CHPs without ABSs have been considered).

The detailed method for evaluating the best CHCP system is out of the scope of this paper so that only the final results will be presented.

The CHCP system with best performances is composed by:

- Internal combustion engine with 526 kW of electrical power and 656 kW of thermal power
- Absorption cycle with 209 kW of cooling power

The economical results are shown in Table 3 where:

- I is the initial cost
- NPV is the Net Present Value
- DPBP is the Discounted Pay Back Period
- IRR is the Internal Rate of Return

For more detail about the economic indicator see reference [6].

Finally the energetical results are summarized in Table 4.

Table 3 – Economical results (CHCP)

I	NPV _(15 years)	DPBP	IRR
€	€	years	%
551950	1398209	3.01	37

Table 4 – Energetic results (CHCP)

Working hours	4928	
Fuel Consumption	6758111	[kWh]
Electricity production	2592128	[kWh]
Electricity selfconsumption	2513825	[kWh]
Thermal energy production	3232768	[kWh]
Thermal energy selfconsumtion	2562657	[kWh]
Thermal waste	219939	[kWh]
Cooling power produced with ABS	337629	[kWh]
Primary Energy Savings (PES)	37	[%]
Thermal Limit (LT)	54	[%]
CO ₂ reduction	611	[tCO ₂]
CO ₂ reduction spec	31	[%]

In Table 4 the rows concerning PES and LT need a deeper explanation. The PES can be calculated with equation (3)

$$PES = \frac{E_{SP} - E_{CHP}}{E_{SP}} \quad (3)$$

Where:

- E_{SP} is the primary energy consumption with separate production of electricity and heating
- E_{CHP} is the primary energy consumption of the CHP

The TL indicator can be calculated with equation (4)

$$L_T = \frac{E_t}{E_e + E_t} \quad (4)$$

Where:

- E_e is the electrical energy produced by a section of CHP production
- E_t is the thermal energy produced by a section of CHP production and really used for industrial or civil purposes

These two indicators are necessary in Italy for defining a CHP unit. A cogenerator is officially defined a CHP if are satisfied the following constraints:

- 1) IRE > 0.05 (5%) for existing section
0.08 (8%) for extended part of existing section
0.1 (10%) for new section
- 2) L_T > 0.33 (33%) for size up to 10 MWe
0.22 (22%) for size between 10 and 25 MWe
0.15 (15%) for size over 25 MWe

4. PV SYSTEM PRELIMINARY DESIGN

The PV system will be installed on the roof of the parking. During a PV system feasibility study the variables with more influence on the installable power are the economic capability of the investor and the area available for the module installation. These two constraints lead us to the choice of a PV system of 50 kW_p.

The PV system energy production can be evaluated by this simple formula:

$$E_{PV} = I \cdot S \cdot \eta_{PV} \cdot \eta_g \quad (5)$$

where:

- I is the Irradiation on the surface modules [kWh/m²]
- S is the total surface of the PV systems [m²]
- η_{PV} is the module efficiency
- η_g is the global efficiency of the other components of the system (inverter, cable, etc...). Usually is considered 75%.

Considering that the module efficiency is defined in Standard Test Conditions (STC), i.e. irradiance 1 kW/m² (here the other parameters defined in the STC, like cell temperature can be neglected), η_{PV} can be written introducing the nominal power of the system (P_n):

$$\eta_{PV} = \frac{P_n [kW]}{1 \left[\frac{kW}{m^2} \right] S [m^2]} \quad (6)$$

Using equation (6) in equation (5) and doing some simplification we obtain:

$$E_{PV} = h_s \cdot P_n \cdot \eta_g = h_{eq} \cdot P_n \quad (7)$$

where:

- h_s are the equivalent hours of the sun
- $h_{eq} = h_s \cdot \eta_g$ are the equivalent hours of the PV system

The parameter h_{eq} depends on the geographical latitude and on the module orientation. In the city of Torino, for PV system with optimal tilt angle (34°) oriented in south direction, the h_{eq} is equal to 1167 hours. Therefore the electricity production of the PV system is:

$$E_{PV} = 1167(\text{hours}) \cdot 50(\text{kW}) = 58530 \text{ kWh}$$

This production corresponds to 28.91 tCO₂ reduction. In Table 5 the economical result for the PV system are shown.

Table 5 – Economical result (PV)

I €	NPV _(20 years) €	DPBP anni	IRR %
301135	247407	8.2	13.6

5. CONCLUSIONS

The energetic balance of a small district in Torino has been done in order to evaluate the benefits of the distributed generation. The new energy network has been designed in order to connect all the single user together and two different technologies for DG will be implemented: a trigeneration plant and a PV system.

The aim of the paper is to promote the possible results achievable using DG generation from the economical and environmental point of view. In general, for a trigeneration system, the higher is the power of the plant the higher will be the final gain in both cases. Of course the power of the plant is limited by the user consumption because the final result depends on the energy supplied to the local user. In other words, if the CHCP plant size is too big a lot of energy waste will be done. Therefore a trigeneration plant needs to be very carefully designed on the basis of the actual user load profiles for being sure to achieve calculated results.

Finally, a PV system production has been introduced which is relatively low with respect to the parking consumption but enough for the charging activity of the electric buses. This is in any case a good result because usually electric buses are a weak solution to the environmental problem, i.e. they are emission free from the local point of view but their energy needs are satisfied by power plant far away from the urban centre. Under

this configuration and from the global point of view the electric buses don't give any help to the environmental problem. In the future the PV plant will supply enough energy for the electric buses so that the public transport performed by means of electric buses in Torino can be defined emission free.

6. REFERENCES

- [1] Commission staff working document, "A European Strategy for Sustainable, Competitive and Secure Energy", Brussels, 2006
- [2] APAT Report, "Analisi dei fattori di emissione di CO₂ dal settore dei trasporti", Roma,, 2003
- [3] EDUCOGEN Report, "A guide to cogeneration", Brussels,, 2001
- [4] EDUCOGEN Report, "The European Educational Tool on Cogeneration", Brussels,, 2001
- [5] ENEA Report, "Intervento di cogenerazione per il complesso ospedaliero Fondazione Santa Lucia", Roma, 2000
- [6] F. Karagiannis, "Central cogeneration units in athens-an economical approach," in Electrotechnical Conference, 2000. MELECON 2000. 10th Mediterranean, vol. 3, 29-31 May 2000, pp. 1032–1035, vol.3.