

**Theme: Innovation in Food Technology***Research paper***Analysis on Wideband Band Pass Filter Microwave Sensor Performances for Measuring Rice Quality in Agriculture Industry****Ameerul Fiqri Abu Bakar<sup>1</sup>, Dyg Norkhairunnisa Abang Zaidel<sup>1\*</sup>, Dyg Azra Awang Mat<sup>1</sup>, Shafrida Sahrani<sup>1</sup>, Kismet Hong Ping<sup>1</sup>, Mohd Ridhuan Mohd Sharip<sup>2</sup>, Norhudah Seman<sup>3</sup> and Dayang Norulfairuz Abang Zaidel<sup>4</sup>**<sup>1</sup>Applied Electromagnetic Research Group, Department of Electrical and Electronic Engineering, Faculty of Engineering, Universiti Malaysia Sarawak, Kota Samarahan, 94300, Sarawak<sup>2</sup>Department of Electrical and Electronics Engineering, Universiti Malaysia Sarawak, Kota Samarahan, 94300, Sarawak<sup>3</sup>School of Electrical Engineering, Faculty of Engineering, Universiti Teknologi Malaysia, 81310 Johor Bahru, Malaysia<sup>4</sup>School of Chemical and Energy Engineering, Faculty of Engineering, Universiti Teknologi Malaysia, 81310 Johor Bahru, Malaysia**\*Corresponding author's email address:** [azdnorkhairunnisa@unimas.my](mailto:azdnorkhairunnisa@unimas.my)

Received: July 19, 2018/ Accepted: September 12, 2018/ Published online: September 17, 2018

Academic Editor: William Riley

**To cite this article:**Bakar A.F. A., Zaidel, D.N.A., Mat, D.A.A., Sahrani, S., Ping, K.H., Sharip, M.R.M., Seman, N. and Zaidel, D.N.A. (2018). Analysis of microwave sensor design using wideband band pass filter for measuring rice quality in agriculture industry. *Asia-Pacific Journal of Food Safety and Security*, 4(2), 53-62.**Highlights**

- Microwave sensor can be the substitute to the available rice assessing measurement equipment in the market.
- Band pass filter can act as the microwave sensor.
- The Type 2 band pass filter design shows the most reliable performances among the three designs.

**About Author**

**Dyg Norkhairunnisa Abang Zaidel** received her B.Eng. in Electrical Engineering (Telecommunications) degree from Universiti Teknologi Malaysia, Johor, Malaysia, in 2010. She completed her PhD degree in the same university in 2014. She is now currently a Senior Lecturer in Universiti Malaysia Sarawak. Her research interests include microwave devices and smart antenna beam forming system.

---

## Abstract

This paper introduced the analysis of three microstrip band pass filter designs which can work as a microwave resonator/sensor to measure the quality of rice. To maintain the tight coupling for over a wideband frequency range, all of the designs implemented broad-side coupling microstrip-slot technique into the design. The analysis shows that band pass filter Type 2 has the best performance compared to the other two designs; where the return loss is -25.3 dB and insertion loss is -0.1 dB. This is due to the signal that can transfer effectively in the ring-shaped patch (comparing Type 1 with Type 2 and Type 3) and with thicker ring (comparing Type 2 and Type 3). The advantage of using the wideband band pass filter as a microwave resonator/sensor is compact in size and low manufacturing cost.

**Keywords:** agricultural microwave resonator; band pass filter; broadside-coupling technique; measuring rice quality; wideband

## 2- Introduction

For centuries, rice has been known as a staple food in Asian countries across all income classes. Annually, it is reported that up to 100 kg per capita of rice is consumed by the Asian [1] which proved that rice has been the main source of carbohydrate. However, in the last four decades, the consumption of rice has been declined especially in Japan and South Korea. In Malaysia, the declination has been reported since the last two decades which is due to the changes in diet. Nowadays, the trend in eating fast-food has been growing and people also tend to choose wheat-based product. These trends will affect the income for the rice producing countries such as Thailand and Malaysia which has become a national issue.

In Malaysia, the demand of rice is always greater compared to other domestic production such as rubber, timber and tobacco [2]. For example, in 1985, 1.26 million tonnes of rice was produced and being distributed to both Peninsular and East Malaysia with the self-efficiency of 84% and 43%, respectively. Meeting the rice demand is always related with the rice availability, quality control and country's economy. Few factors that are important in assessing the perfect characteristic of rice include the size and shape of the grain, color, head rice recovery and chalkiness [3].

Measurement analyzer and sensor have been produced to assess the quality of rice including texture analyzer, scanning electron microscope, field emission scanning microscope and etc. This equipment is highly accurate but very expensive [4]. Therefore, to cater this problem, one of the ways is to develop a band pass filter. A band pass filter is a microwave device that can act as a microwave sensor. This sensor can be used in industrial application especially in assessing the quality of rice. The development of microwave sensors technology has been started since 1960's [5]. Previous studies have introduced a few types of microwave sensors such as radiometer sensor, resonator sensor and transmission sensor [5]. In order to design the band pass filter, several important parameters need to be taken into consideration which include; the dielectric constant of the substrate, permittivity of the substrate and permittivity of the subject (rice).

Band pass filter is known as an important device in many radio frequency (RF) and microwave applications as a frequency selective device [6]. It can be realized either by using distributed circuit or lumped elements. However, a few decades ago, due to the advantages that microstrip technology have brought to microwave applications such as easier to fabricate, small in sizes and low cost, the microstrip technology has always been chosen to be the best way to offer low cost microwave devices. There are several topologies to implement microstrip technology into the band pass filter design such as parallel-coupled [7], hairpin [8], interdigital [9] and end-coupled filters [10-11].

Meanwhile, the industrial, scientific and medical band or known as ISM band is an unlicensed band which has been reserved internationally for the use of RF electromagnetic fields for industrial, scientific and medical purposes other than communications. Two basic frequencies that have been allocated by the US Federal Communications Commission (FCC) for the ISM band are 915 MHz and 2.45 GHz. Due to the suitability compromise between power deposition and penetration depth, 2.45 GHz has been the best choice to be used by many applications such as WLAN, Bluetooth and cordless phone.

In this paper, three designs of microstrip band pass filter were introduced. Each one of the band pass filter comprehend different performances in terms of the scattering parameter, insertion loss and bandwidth. Thus, the objective of this paper was to compare the performance of the three microstrip band pass filter designs and the best design will be adapted as the microwave sensor. This sensor can be used in industrial application which is lower in cost compared to available measurement equipment in the market. The band pass filters will be designated to be operated at industrial, scientific and medical band (ISM band) which is at 2.45 GHz. Advanced Design System (ADS) software was used to analyze and design the band pass filter. Rogers RO4003C was chosen as the substrate for the band pass filter.

### 3- Design and Analysis

In microwave, a device or system which can operate by at least 1 GHz frequency range can be considered as a wideband device or system. The band pass filters that operate in a wideband frequency range need to have low insertion loss, flat delay performance within the operated frequency range and a good exclusion characteristic [12]. Four reliable structures that can be implemented to have a wideband band pass filter design include, i) three-line microstrip structure, ii) broadside-coupled using microstrip and coplanar waveguide (CPW), iii) microstrip multiple mode resonator (MMR), the combination of high pass filter and low pass filter, and iv) edge coupled microstrip [13]. It is hard to design and develop a band pass filter that comprise of 80% of fractional bandwidth value due to the limitation of the coupling among the resonators. Thus, the broadside-coupled structure was chosen as it can provide very tight coupling [12,14] compared to the other structures and the fabrication process for this type of structure is easier. The design of the broadside-coupled filter is restricted by the coupling factor (CF) between the slot-line and the stubs. This will affect the design filters which are prone to alignment errors. CF can be calculated by solving (1), (2) and (3) [12].

$$S_{11ef} = S_{11} + \frac{S_{21}^2 S_{11}}{1 - S_{21}^2}, S_{21ef} = \frac{S_{21}^2}{1 - S_{21}^2} \quad (1)$$

$$S_{11} = \frac{1 - CF^2(1 - \sin^2(\beta_{ef}l))}{(\sqrt{1 - CF^2} \cos(\beta_{ef}l) + j \sin(\beta_{ef}l))^2} \quad (2)$$

$$S_{21} = \frac{j2CF\sqrt{1 - CF^2}\sin^2(\beta_{ef}l)}{(\sqrt{1 - CF^2} \cos(\beta_{ef}l) + j \sin(\beta_{ef}l))^2} \quad (3)$$

where,  $S_{11}$  and  $S_{21}$  are the scattering parameters of the return loss and insertion loss, respectively, for one section of the coupled structure.  $CF$  is the coupling factor between the top layer and the bottom layer.  $\beta_{ef}$  is the effective phase constant in the medium of the coupled structure. Meanwhile,  $l$  is the physical length of the coupled structure.

The value of  $CF = 1/\sqrt{2}$  was chosen to design the filters since it gives the finest performance [12]. To eliminate harmonic responses, the coplanar waveguide (CPW) that connected the two sections must be changed to stepped-impedance resonator (SIR) and formed overlapped band pass filter. The coupled band pass filter connected by using SIR allowed the false responses to be eliminated. The length of SIR can be obtained by using (4) [12].

$$l_{sir} = 2 \lambda_e \tan^{-1} \sqrt{Zr/\pi} \quad (4)$$

where,  $Zr$  is the ratio of the impedance of the two ends of the SIR to impedance of the middle section of the SIR.  $\lambda_e$  can be calculated using (5) [15].

$$\lambda_e = c/f\sqrt{\epsilon_e} \quad (5)$$

Three designs of wideband band pass filters were introduced in this paper; Type 1, Type 2, and Type 3 as shown in Figure 1, Figure 2 and Figure 3, respectively. Each of the design consists of two layers; the top patch and the bottom patch. It has two ports, Port 1 and Port 2 on the top patch. Also, broadside coupled were implemented on the top patch of all the filters. On the bottom patch, microstrip slot was added as coupler for the top patch.

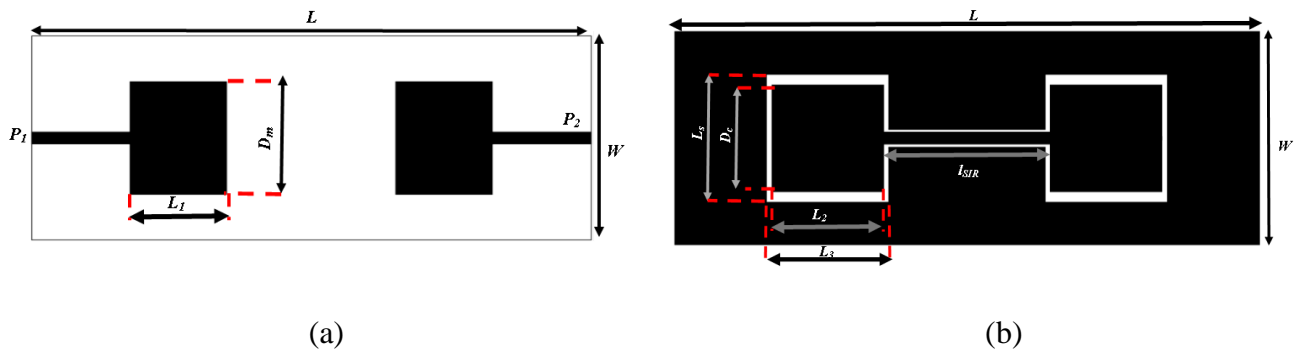

**Figure 1.** Type 1 wideband band pass filter (a) top view (b) ground (bottom view)

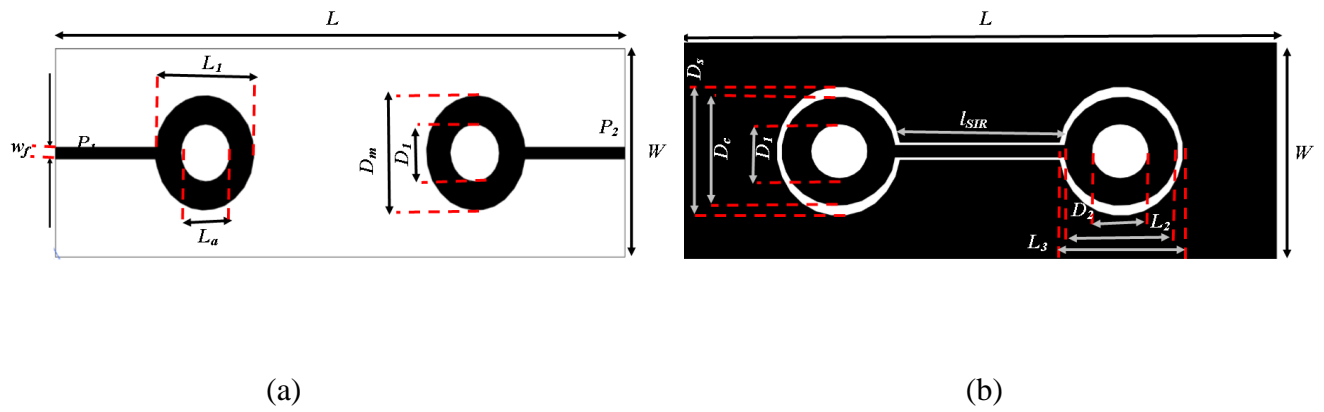

**Figure 2.** Type 2 wideband band pass filter (a) top view (b) ground (bottom view)

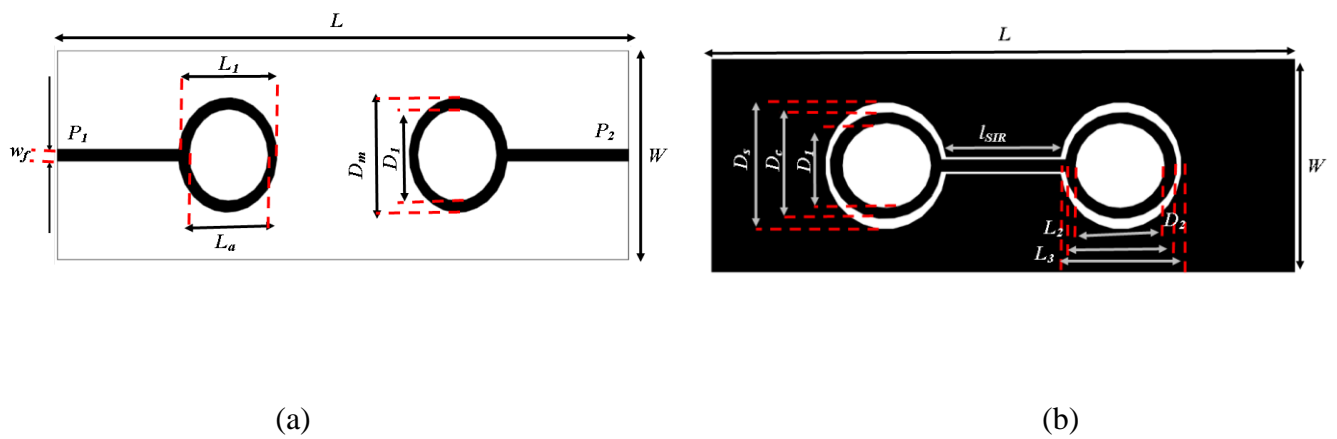

**Figure 3.** Type 3 wideband band pass filter (a) top view (b) ground (bottom view)

Figure 1 shows the Type 1 band pass filter with rectangular shaped for both the broadside on the top patch and the microstrip slot at the ground patch. Figure 2 and Figure 3 show the Type 2 and Type 3 band pass filter design. The top patch of the filter consists of elliptical broadside however the radial slot dimensions,  $D_m$  minus  $D_1$ , are different. The ground patch for Type 2 and Type 3 consisted of radial slot with different dimension as indicated by the labels in each drawing. The band pass filters were designed to operate at the wideband frequency. The central frequency of the wideband band pass filter is 2.45 GHz. The length of stepped impedance resonator,  $l_{sir}$  at the ground patch can be calculated by using (4). The parameters stated in Figure 1 to Figure 3 are summarized in Table 1.

#### 4- Results and Discussions

All of the wideband band pass filters were simulated using ADS Design Studio and the results are shown in Figure 4 and Figure 5. Figure 4 shows the return loss,  $S_{11}$  parameter while Figure 5 shows the insertion loss,  $S_{21}$  parameter. The  $S_{11}$  and  $S_{21}$  parameters were analyzed whether the return loss and insertion loss were in the acceptable range. Theoretically, the  $S_{11}$  parameter should be below -10 dB while the  $S_{21}$  parameter should be approaching 0 dB. The performance of these filters was compared and analyzed to observe the effect of the implementation of the microstrip slots in the patch and the

ground. From the comparison of the results obtained, the wideband band pass filter with the best performance was determined.

**Table 1.** Parameters of wideband band pass filters

Parameter	Dimension of band pass filter (mm)		
	Type 1	Type 2	Type 3
$D_c$	10	10	10
$D_m$	11	11	11
$D_s$	12	12	12
$D_1$	-	5.5	8.8
$D_2$	-	5.25	8.4
$W$	20	20	20
$W_f$	1.13	1.13	1.13
$L$	55	55	55
$L_1$	9.5	9.5	9.5
$L_2$	0.5	10.5	10.5
$L_3$	1.5	11.5	11.5
$L_a$	-	4.75	7.6

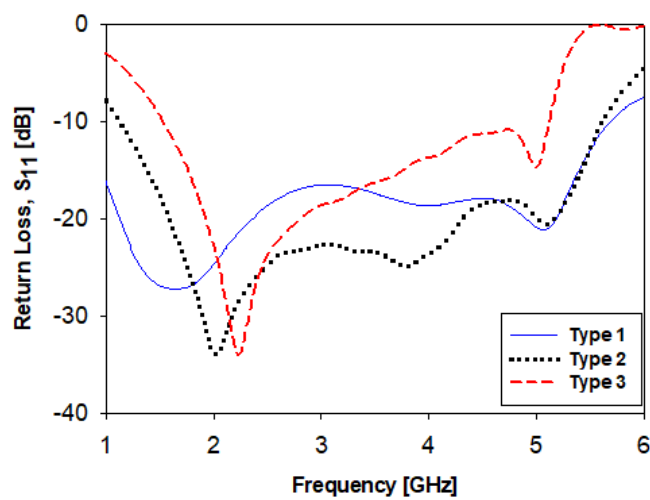

**Figure 4.** Return loss,  $S_{11}$  performances for all types of band pass filter design

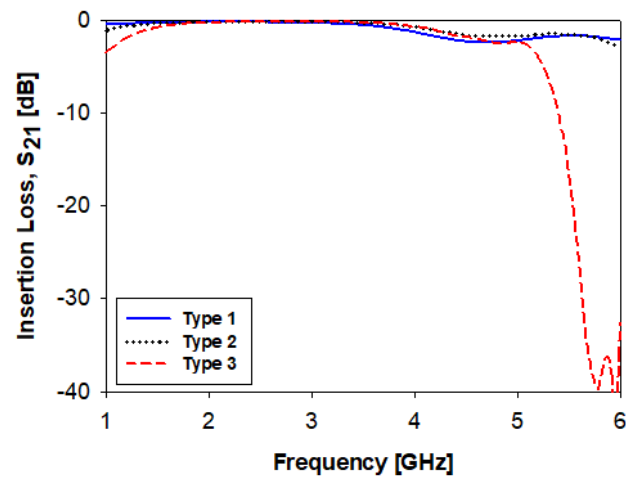

**Figure 5.** Insertion loss,  $S_{21}$  performances for all types of band pass filter design

Based on Figure 4 and Figure 5, Type 3 shows a large pass band ripple in which was not practical for filter design. An ideal filter requires high return loss and low insertion loss to allow for the signal to be transmitted with minimum reflected signal towards the source and least signal loss during transmission from in and out of the filter. Besides that, Type 3 filter has small bandwidth compared to Type 1 and Type 2. Type 1 has the widest bandwidth which is the rectangular shaped, while Type 2 and Type 3 were second and third, respectively, based on bandwidth. The possible explanation for the bandwidth difference is that the existence of the slot which is presence in Type 2 and Type 3 ground and patch while Type 1 has no slot in either ground or patch which was mentioned in previous study [12]. The author has reported that the purpose of the slot was to create an attenuation pole at the mid-band frequency of the stop band which will reduce the bandwidth.

This statement is supported by a different study [16] that bandwidth is easily affected by the slot in patch and in ground. However, Type 2 was closer to ideal case which it has high return loss and low insertion loss compared to Type 1. As mentioned by the author in [17] the slot dimension can be tuned to boost return loss and reduce insertion loss to improve the filter responses. Also mentioned in [16] the proper selection of slot size can improve the efficiency of the device. Another possibility for better response in Type 2 design is the presence of step impedance in the broadside microstrip. This is explained by previous study [18] where the step impedance provides progressive changes in impedance along the transmission line to reduce the losses which allow a solid rise of the characteristic impedance lead to better impedance matching. Therefore, it can be concluded that Type 2 was more efficient compared to Type 1 since Type 2 has better feedback than Type 1. The results of the three filters are tabulated in Table 2.

**Table 2.** Summary of the return loss ( $S_{11}$ ) and insertion loss ( $S_{21}$ ) of all types wideband band pass filter

Parameter	Wideband Band Pass Filter		
	Type 1	Type 2	Type 3
Return Loss, $S_{11}$ (dB)	-19.1	-25.3	-25.1
Insertion Loss, $S_{21}$ (dB)	-0.3	-0.1	-0.2
Operating Frequency Range (GHz)	0.8 - 5.7	1.1 - 5.6	1.5 - 5.1
Bandwidth (GHz)	4.9	4.5	3.6

## 5- Conclusion

In brief, three designs of wideband band pass filter are presented in this paper. All of the designs implemented broadside-coupling technique to provide a very tight coupling between top and bottom patch design and this also leads to compact in size devices. Each one of the designs shows different performances in terms of return loss, insertion loss and bandwidth. Based on the analysis, Type 2 has shown the best performances compared to the other two designs. This is due to the signal that can transfer effectively in the ring-shaped patch (comparing Type 1 with Type 2 and Type 3) and with thicker ring (comparing Type 2 and Type 3). The wideband band pass filter shows good performances which can be used as a microwave resonator to measure the quality of rice.

## References

- [1] Ricepedia. The global staple. <http://ricepedia.org/rice-as-food/the-global-staple-rice-consumers> (accessed on 10 July 2018).
- [2] Wong, L. C. Y., Husain, A. A., and Ithnin, B. (1992). Consumer demand for rice grain quality. International Rice Research Institute.
- [3] Irri. Grain quality and nutrition center. <http://irri.org/about-us/our-organization/grain-quality-and-nutrition-center> (accessed on 10 July 2018).
- [4] Robbins, P., Bikande, F., Ferris, S., Kleih, U., Okoboi, G., and Wandschneider, T. (2004) Guide to collective marketing for small-scale farmers. Ibadan, Nigeria. International Institute of Tropical Agriculture (IITA).
- [5] Hong J. S. G. and Lancaster M.J. (2001). Microstrip Filters for RF/Microwave Applications, Wiley, New York.
- [6] Pozar D. M. (2005). Microwave Engineering, 3rd ed., J. Wiley & Sons.



- 
- [7] Saha P.B., Roy S. and Bhowmik M. (2015). Improvement of parallel coupled bandpass filter using coupled closed loop square resonator structure. *International Conference on Signal Processing and Integrated Networks (SPIN)*. 66-68
- [8] Shaman H., Almorqi S., Haraz O. and Alshebeili S. (2014). Hairpin microstrip bandpass filter for millimeter-wave applications. *Proceedings of 2014 Mediterranean Microwave Symposium (MMS2014)*. 1-4.
- [9] Périgaud A., Bila S., Verdeyme S., Baillargeat D. and Kaminsky D. (2016). Multilayered Coupled Interdigital Resonator Filters for General Chebyshev Filtering Functions. *IEEE Transactions on Microwave Theory and Techniques*. 64(5). 1465-1475.
- [10] Lindo A. O. and et.al. (2009). Parallel and end coupled microstrip band pass filters at W-band. *Asia Pacific Microwave Conference*. 345-348.
- [11] Contreras A., Ribo M., Pradell L. and Blondy P. (2013). Uniplanar Bandpass Filters Based on Multimodal Immitance Inverters and End-Coupled Slotline Resonators. *IEEE Transactions on Microwave Theory and Techniques*. 61(1). 77-88.
- [12] Abbosh, A., Bialkowski, M., Ibrahim, S. (2010). Ultra-wideband band pass filters using broadside-coupled microstrip-coplanar waveguide. *IET Microwaves, Antennas and Propagation*. 5(7)
- [13] Li K., Kurita D. and Matsui T. (2005). An ultrawideband band pass filter using broadside-coupled microstrip-coplanar waveguide structure. *IEEE MTT-S International Microwave Symposium Digest*.
- [14] Tripta, A. and Ghazali, N. (2016). Broadside-coupled uwb filter for indoor communication systems. *International Conference on Wireless Communications, Signal Processing and Networking (WiSPNET)*
- [15] Virdee Bal S., Avtar S. Virdee, Ben Y. Banyamin. (2004). *Broadband Microwave Amplifiers*. Norwood, MA: Artech House, Inc;
- [16] Kumar R., J. P. Shinde and M. D. Uplane. (2009). Effect of Slots in Ground Plane and Patch on Microstrip Antenna Performance. *International Journal of Recent Trends in Engineering*. 2
- [17] Yaqeen S. M. and Halil T. E. (2016). Investigation of New Microstrip Bandpass Filter Based on Patch Resonator with Geometrical Fractal Slot.
- [18] Zaidel, D. N. A., Rahim, S. K. A., Seman, N., and Dewan, R. (2015). Design of Ultra Wideband Phase Shifter with Improved Scattering Parameter Performances. *International Conference on Advances of Electrical, Electronic and Systems Engineering*.

---

© 2018 by the author; licensee 2050Science Publishers, Christchurch, New Zealand. This is an open access article distributed under the Creative Commons Attribution License, which permits unrestricted use, distribution, and reproduction in any medium, provided the original work is properly cited.