

Development of a universal DC power supply using solar photovoltaic, utility and battery power sources

Joe Oladosu Oni

Department of Electrical/ Electronics Engineering, Olabisi Onabanjo University, Ibogun Campus, Ogun State, Nigeria

Bukola Olalekan Bolaji

Department of Mechanical Engineering, University of Agriculture, Abeokuta, Nigeria

Abstract

In this paper, a universal direct current (DC) power supply system was developed and tested in order to provide uninterrupted power for DC appliances. The system employs simple Diode OR logic for the three power sources (mains from utility power supply, the solar photovoltaic and battery). The parallel combination of the three diodes at the output functions like a comparator circuit and compares the outputs voltage of the three sources, so that the highest voltage at a particular time feeds the DC output and supplies the charging current to the battery. The universal DC power supply system was tested under various operating conditions and the results obtained showed a good performance of the system. The system outputs, when all the power sources were available, during utility power failure and when only the stored energy in the back-up battery was available were 13.8, 13.1 and 12.2V, respectively. The system guarantees an uninterrupted power supply, which can be used to power telecommunication equipment, audiovisual materials, computers, DC motor driven devices and other DC appliances. A typical day solar radiation varied from 547 W/m² to 865 W/m² while the generated voltage from PV varied from 11.8 V to 13.7 V. The generated voltage from solar power source increases with the increase in solar radiation.

Keywords: battery, direct current, photovoltaic, power, solar, universal

1. Introduction

Energy is vital input for sustainable development and economic growth for any country. Electrical energy is considered a most convenient form of energy sources in rural and urban areas. The seemingly unending power outages by the Power Holding Company of Nigeria (PHCN) calls for a reliable, safe and efficient alternative, which will guarantee an uninterruptible power supply to run several domestic, industrial and commercial systems. The main sources of power generation today are fossil fuels and nuclear reactors. These are depletable, non-renewable and pollute the environment. Moreover, the exploration of these resources is expensive. Hydro energy is also used, but it does not produce adequate and consistent power for the nation's consumption (Adu and Bolaji, 2004).

In many parts of the world there is growing awareness that renewable energy has an important role to play in the provision of social amenities such as potable water and electricity. Among the various types of renewable energy, special attention has been given to solar energy because it is freely available. According to Bolaji and Adu (2007), solar energy is the driving force behind several of the renewable forms of energy. Solar energy is an ideal alternative source of energy because it is abundant and inexhaustible.

Nigeria like most tropical countries is blessed with large amounts of sunshine all year round. For instance, it receives about 490 W/m² of sunshine per day (Bamiro and Ideriah, 1982). From the research carried out by Fagbenle (1991), a very high insolation, as much as 37639 kJ/m² in August, was attained in Makurdi, Nigeria. Therefore, positive results are expected from solar energy utilization in Nigeria.

Photovoltaic energy is the conversion of sunlight into electricity through a photovoltaic cell, commonly called a solar cell. Sunlight is composed of photons, or particles of solar energy. These photons contain various amounts of energy corresponding to the different wavelengths of the solar spectrum. When photons strike a photovoltaic cell, they may be reflected, pass right through, or be absorbed. Only the absorbed photons provide energy to generate electricity. When enough sunlight (energy) is absorbed by the material (a semiconductor), electrons are dislodged from the material's atoms. Special treatment of the material surface during manufacturing makes the front surface of the cell more receptive to free electrons, so the electrons naturally migrate to the surface (EIA, 2004).

When the electron leaves their position, holes are formed. When many electrons, each carrying a negative charge, travel toward the front surface of the cell, the resulting imbalance of charge between the cell's front and back surface creates a voltage potential like the negative and positive terminals of a battery. When the two surfaces are connected through an external load, electricity flows. Individual cells can vary in size from about 1 cm to about 10 cm across. However, one cell only produces 1 or 2 watts, which is not enough power for most applications. In order to increase power output, cells are electrically connected into a packaged weather-tight module. Modules can be further connected to form an array (Figure 1). The term array refers to the entire generating plant, whether it is made up of one or several thousand modules (Tiwari, 2002). As many modules as needed could be connected to form the array size.

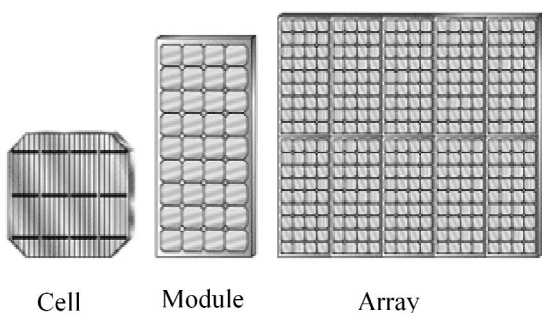

Figure 1: Different arrangement of solar cells

The performance of a photovoltaic (PV) array is dependent upon sunlight. Climate conditions have a significant effect on the amount of solar energy received by a PV array and, in turn, its performance. Most current technology photovoltaic modules are about 10 percent efficient in converting sunlight to electricity. Further researches are being conducted to raise this efficiency to 20 percent and above (Q-Kou *et al.*, 1998; Tripanagnostopoulos *et*

al., 2001; Nemet, 2006; Albrecht, 2007).

Photovoltaic conversion is useful for several reasons. Conversion from sunlight to electricity is direct, so that bulky mechanical generator systems are unnecessary. The solar photovoltaic system has no moving parts, in the field, it requires only a modest amount of skilled labour to install and maintain, making them well suited for developing countries. In order to supply the required power, the arrays should be capable of producing sufficient current and voltage to run the appliances, and it can be connected in series and in parallel to obtain the desired voltage and current, respectively.

The installation of a PV system has been growing by 20–25% per annum over the past 20 years, which is mainly due to the technological advances and increasing production volume of PV components (Jones and Underwood, 2001; Meyer and Luther, 2004). Also, the environmental impact of a photovoltaic system is minimal, requiring no water for system cooling and generating no by-products. Photovoltaic cells like batteries generate direct current (DC) which is generally used for small loads (electronic equipment). When DC from a photovoltaic cell is used for commercial applications or sold to electric utilities using the electric grid, it must be converted to alternating current (AC) using inverters, solid state devices that convert DC to AC (Ordenes *et al.*, 2007; Eltawil and Samuel, 2007).

Many researcher such as Thomachan and Srinivasan (1996); Q-Kou *et al.*, (1998); Beshada *et al.*, (2006); and Bolaji and Adu (2007) have in recent times designed, investigated and developed photovoltaic power which has been utilized in low to medium power applications such as in telecommunication stations, water pumping, refrigeration etc. Most of the researches in this area considered solar power as the sole power source. In this paper, a universal DC power supply, which can automatically switch between power sources, is developed. The system utilizes both solar photovoltaic power and mains from utility power supply, which charges the back-up battery when the radiation from the sun is available at a high intensity or whenever there is a supply from a utility power source. The design arrangement guarantees an uninterrupted power supply.

2. Materials and methods

2.1 Basic theory of photovoltaic cell

In all solar panels a basic solar cell is represented according to the model shown in Figure 2. As shown in the figure, the current generator (I_c) provides a short-circuit current which is a function of the solar irradiation (G) according to an equation determined by the characteristic $I(V)$ provided by the manufacturer (Klein, 1996):

$$I_c = a \cdot G + b \tag{1}$$

where, a and b are constants which depend on photovoltaic cells.

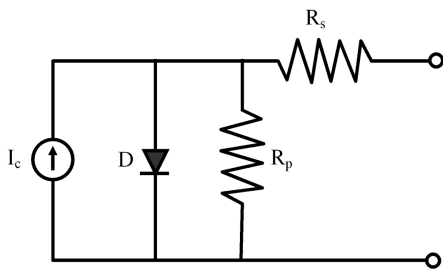

Figure 2: Electric scheme of one photovoltaic cell

Source: Aziz et al., (2006)

In Figure 2, 'D' is a diode whose parameters are given by simulations at the time of the modelling of PV generators. In this diode, the general equation of current (I) is given in Eq. (2) (Aziz et al., 2006):

$$I = I_s \left[\exp\left(\frac{q \cdot V}{\eta \cdot \sigma T}\right) - 1 \right] \quad (2)$$

where, I_s = saturation current; η = idealist factor; V = voltage applied at the diode boundaries; q = electron charge; σ = Stefan Boltzmann constant; and T = temperature. Also, R_s and R_p in Figure 2 are resistances standing for the voltage drops per ohmic contact and leakage current.

2.2 Photovoltaic system

The traditional utility-interactive (UI) photovoltaic system is employed in this work. This is in the form of a hybrid system that combines a photovoltaic power system and utility power system working together to supply the required electricity. This arrangement produced a system with relatively good reliability and cost when compared to increasing the size of the photovoltaic array and battery storage to cover days of extremely poor weather.

2.3 Energy storage device

The solar electric system in design required battery storage. The solar panels charge the battery during daylight hours and the battery supplies the power when it is needed. The photovoltaic system makes use of rechargeable batteries. The rechargeable battery used in this work is the 12V, 120Ah lead-acid type. A lead-acid battery is used because of its low initial cost, its maintenance ability and because they are readily available. The battery operates in parallel with a load and charging sources (solar panel and utility power) at an applied voltage, so that the battery takes a charge from the available charging source which is sufficient to maintain the cells in a fully charged condition indefinitely. The system employs a voltage regulator to

protect the battery from excessive over-voltage conditions. This regulator dissipates any excess energy when the battery bank is fully charged. The charging circuit is shown in Figure 3.

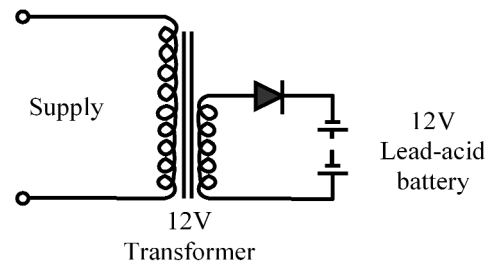

Figure 3: Battery charging circuit

Capacity of the storage device: The system is designed to power DC users of total loads of 30 watts. Energy has units of product of power and time (watt-hours). A 12V, 120 amp-hours battery has energy of 1440 watt-hours (120×12).

$$\text{Time} = \frac{\text{Energy}}{\text{Power}} = \frac{1440 \text{ watt-hours}}{30 \text{ watt}} = 48 \text{ hours}$$

Therefore, the stored energy in the battery will run 30 watt DC loads for 48 hours (2 days) without any supply from both the solar panel and utility.

2.4 Mains section (transformer)

Since the required output voltage is +12V, a 15V r.m.s. transformer is chosen and a transformer with an output current rating of 200 mA is chosen to allow for wide variations in different power rating of different DC users. The rectifier section consists of four diodes connected in the bridge configuration. Filtering was achieved with aid of a comparator ($1000\mu\text{f}$, 25V) large enough to remove enough AC components (ripples). An IC type voltage regulator was used to counter the problems of charging output voltage under varying load conditions. The combined circuit diagram for the transformer, rectification and regulation is shown in Figure 4.

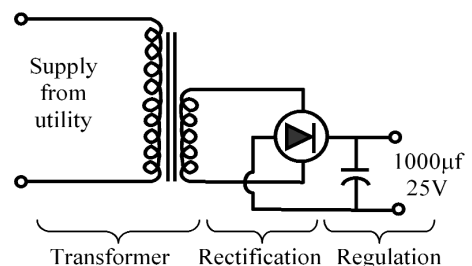

Figure 4: Combined circuit diagram for mains section

2.5 Principle of operation

The complete circuit diagram for the universal power supply is shown in Figure 5. The basic operation of the circuit is centred on the characteristics

of D_5 - D_6 , D_7 and D_8 network, which forms a 3-input Diode-OR logic gate. The parallel combination of these three diodes compares the output voltage of the three sources. In this arrangement, the highest voltage at a particular time feeds the DC output and supplies the charging current to the battery. Many researchers such as Khedari *et al.* (2004); Carr and Pryor (2004); and Park *et al.* (2010) have also used a diode in controlling and regulating the operation of photovoltaic (PV) power generating systems.

2.6 Experimental test analysis

The DC voltage was measured with the help of a fluke 73 series multi-meter (connected in series). The short circuit current was measured with the help of an ammeter. The global solar radiation was measured using a thermoelectric Kipp and Zonen pyranometer (B.V. model CM 11, accuracy ± 1.0 W/m²). The system was connected to 30 watt DC loads and tests were conducted under various operating conditions.

3. Results and discussion

The results obtained during the performance test are shown in Tables 1 to 3. Table 1 shows the results obtained when power was available through the three power sources (solar, utility and battery). As shown in this table, the output from the system was 13.8V and the highest voltage between solar and utility, through the feedback connection of D_9 and D_{10} diode gates was responsible for the battery charging. This was the best output obtained as expected.

Table 2 shows the results obtained during utility power failure, and available power was through solar and battery. As shown in this table, the output from the system was 13.1V and power from solar through the feedback connection of D_{10} diode gate was responsible for the battery charging.

Table 3 shows the results obtained when the battery was the only power source. The powers from both the solar photovoltaic (PV) and utility sources were cut-off to test the capacity of the storage device. As shown in this table, the system output was 12.2V. There was no charging of the battery, the battery only discharges the stored energy in it during this time. At this condition, the output was used to carry 30 watt DC loads for 46 hours.

Figure 6 shows the variations of solar radiation with the time of day for a typical experimental run. As shown in the figure, the solar radiation intensity was high about mid-day when the sun is usually overhead.

Figure 7 shows the variations of the generated voltage from the solar panel with the time of day for a typical experimental run. Comparison of Figure 7 with Figure 6 showed that the generated voltage from PV increases with the increase in solar radiation. The solar radiation varied from 547 W/m² to 865 W/m² while the generated voltage from solar power source varied from 11.8 V to 13.7 V.

Table 1: Test results with power from solar, utility and battery

Power source	Voltage (V)	System output (V)
Solar	13.5	
Utility	15.0	13.8
Battery	12.8	

Table 2: Test results with power from solar and battery

Power source	Voltage (V)	System output (V)
Solar	13.7	
Utility	0	13.1
Battery	12.7	

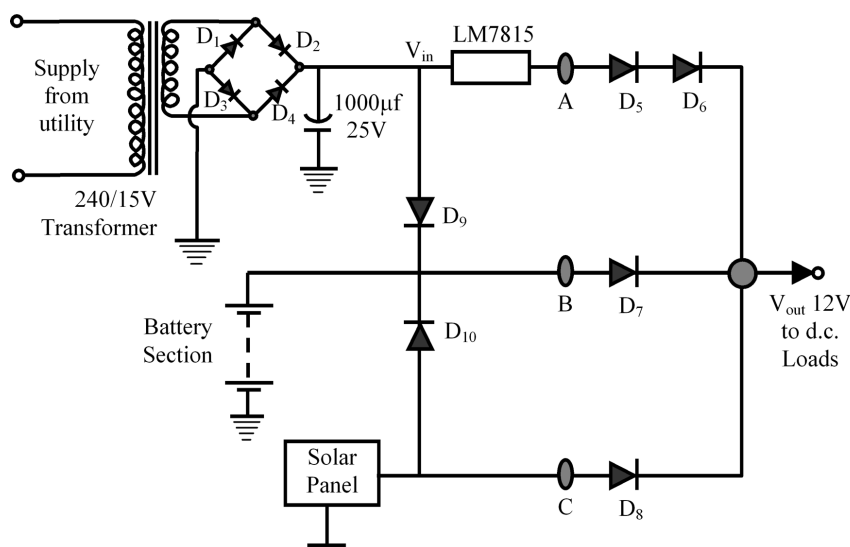

Figure 5: Universal power supply circuit

Table 3: Test results with power from battery only

Power source	Voltage (V)	System output (V)
Solar	0	12.2
Utility	0	
Battery	12.5	

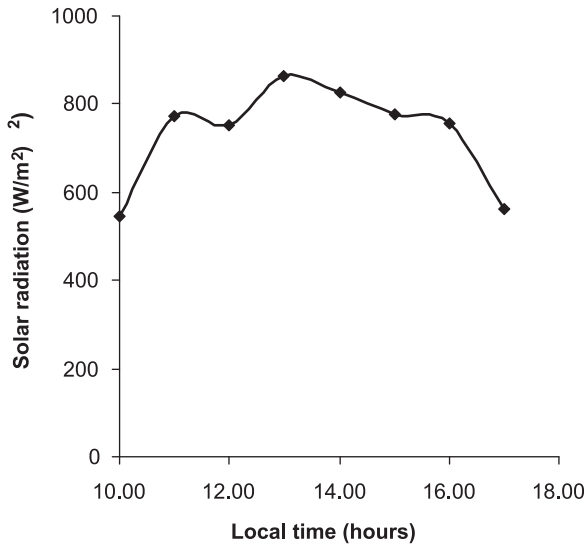

Figure 6: Variation of solar radiation with the time of the day for a typical experimental run

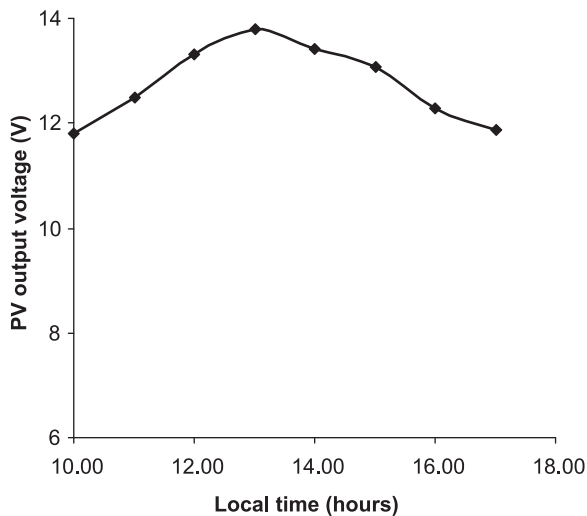

Figure 7: Variation of the generated voltage from solar panel with the time of the day for a typical experimental run

4. Conclusion

In this paper, a universal power supply system was developed to utilize solar photovoltaic (PV) power and mains from a utility power supply to feed the DC outputs and charge the back-up battery. Charging of the battery is carried out during the daylight when there is appreciable radiation intensity or whenever there is a supply from the utility power source. The system employs simple Diode

OR logic for the three power sources (mains from utility power supply, solar panel and battery). The parallel combination of these three diodes at the output functions like a comparator circuit and compares the outputs voltage of the three sources so that the highest voltage at a particular time feeds the DC output and supplies the charging current to the battery.

The system was tested under various operating conditions and the output was 13.8V when all the power sources were available, while 13.1V output was obtained during utility power failure and the solar power source was responsible for the battery charging. The output when the system depended solely on the energy stored in the back-up battery was 12.2V, which powered 30 W DC. loads for 46 hours without any power supply from both the solar panel and utility. A typical day solar radiation varied from 547 W/m² to 865 W/m² while the generated voltage from PV varied from 11.8 V to 13.7 V. The generated voltage from the solar power source increases with the increase in solar radiation.

References

- Adu, M.R. and Bolaji, B.O. (2004). Possibility of rural electrification through solar energy in Nigeria. *Proceedings of 5th Annual Engineering Conference of School of Engineering and Engineering Technology*, Federal University of Technology Minna, Nigeria: 105–111.
- Albrecht, J. (2007). The future role of photovoltaics: a learning curve versus portfolio perspective. *Energy Policy*, 35: 2296–2304.
- Aziz, A., Kassmi, K., Olivie, F. and Martinez, A. (2006). Symbolization of the electric diagram of the marketed solar panels. *Moroccan Journal of Condensed Matter*, 7(1): 38–41.
- Bamiro, O.B. and Ideriah, F.J.K. (1982). Determination of the optimum collector orientation for Ibadan, Nigeria. *Nigerian Journal of Solar Energy*. 2(1): 26–32.
- Beshada, E., Bux, M. and Waldenmaier, T. (2006). Design optimization of a photovoltaic powered grain mill. *Agricultural Engineering International: The CIGR Ejournal*, 8: 1–15.
- Bolaji, B.O. and Adu, M.R. (2007). Design analysis of a photovoltaic pumping system for rural application in Nigeria. *International Journal of Agricultural Sciences, Science, Environment and Technology*, University of Agriculture, Abeokuta, Nigeria, Series B, 6(2): 120–130.
- Carr, A.J. and Pryor, T.L. (2004). A comparison of the performance of different PV module types in temperate climates. *Solar Energy*, 76: 285–94.
- EIA, (2004). Energy Information Administration, Electric Power Annual. Annual Electric Generator Report database, USA.
- Eltawil, M.A. and Samuel, D.V.K. (2007). Vapour compression cooling system powered by solar PV array

- for potato storage. *Agricultural Engineering International: The CIGR Ejournal*, 9: 1–23,
- Fagbenle, R. (1991). Optimum collector tilt angles and average annual global radiation for Nigeria conditions. *Nigeria Journal of Renewable Energy*. 2(1): 9–17.
- Jones, A.D. and Underwood, C.P. (2001). A thermal model for photovoltaic systems. *Solar Energy*, 70: 3639–3644.
- Khedari, J., Waewsak, J., Supheng, W. and Hirunlabh, J. (2004). Experimental investigation of performance of a multi-purpose PV-slat window. *Solar Energy Materials and Solar Cells*, 82, 431–45.
- Klein, S.A. (1996). *TRNSYS Users Manual Version 14.2*, University of Wisconsin Solar Energy Laboratory, Madison, WI.
- Meyer, T. and Luther, J. (2004). On the correlation of electricity spot market prices and photovoltaic electricity generation. *Energy Conversion Management*, 45: 2639–2644.
- Nemet, G.F. (2006). Beyond the learning curve: factors influencing cost reductions in photovoltaic. *Energy Policy*, 34: 3218–3232.
- Ordenes, M., Marinoski, D.L., Braun, P. and Ruther, R. (2007). The impact of building-integrated photovoltaic on the energy demand of multifamily dwelling in Brazil. *Energy and Buildings* 39: 629–642.
- Park, K.E., Kang, G.H., Kim, H.I., Yu, G.J. and Kim, J.T. (2010). Analysis of thermal and electrical performance of semi-transparent photovoltaic (PV) module. *Energy*, 35, 2681–2687.
- Q-Kou, S., Klein, S.A. and Beckman, W.A. (1998). A method for estimating the long-term performance of direct-coupled PV pumping systems. *Solar Energy*. 64(1): 33–40.
- Thomachan, K. and Srinivasan, K. (1996). Photovoltaic panel generator based autonomous power source for small refrigeration units. *Solar Energy*, 56: 543–552.
- Tiwari, G.N. (2002). *Solar Energy Fundamentals, Design, Modelling and Applications*. Narosa Pub. House, New Delhi.
- Tripanagnostopoulos, Y., Nousia, T. and Souliotis, M. (2001). Test results for air cooled modified PV modules. *Proceedings of 17th European PV Solar Energy Conference Munich, Germany*, 2519 – 2522.

Received 15 July 2009; revised 13 August 2010