

# Online Working Drawing Review and Assessment

Jennifer McInnis, Alexandra Sobin, Nicholas Bertozzi

Daniel Webster College

Marie Planchard

Mass Bay Community College

## Abstract

*This paper describes the development and implementation of an online working drawing review video and online assessment tool. Particular attention was paid to dimensioning and ASME ANSI Y14 standards with the goal of improving the quality of the working drawings required in final design project reports. All members of freshmen design teams in the fall 2008 semester were required to watch this video and pass an online assessment before they could turn in their final design project reports. The School of Engineering maintained scanned copies of design project reports for the fall 2006 and 2007 semesters. A separate working drawing assessment rubric was developed and used to evaluate the working drawings for these semesters so that a comparison could be made with the project working drawings submitted for the fall 2008 semester. The working drawing review videos and the online assessment tool are available on request for Engineering Design Graphics (EDG) faculty members.*

## INTRODUCTION

Many first-semester freshman engineering design courses cover a wide range of topics such as the principles of the engineering design process, effective teamwork and project management, engineering graphics, three-dimensional solid modeling, oral and written presentations, an introduction to engineering analysis, and an introduction to specific engineering disciplines through industry tours and speakers. In addition, many include a Conceive-Design-Implement-Operate (CDIO) or similar type of project experience (CDIO Homepage, n.d.). It is difficult to fit all this content into a one-semester course. Often student teams do a good job with the analysis and fabrication of the physical prototypes of their projects; however, their final project reports are usually of lower quality. This seems to be especially true of their working drawings. The students have covered this material and have submitted related drawings assignments successfully earlier in the semester, so the challenge is to find ways to get them to review

this material on their own before turning in their reports without taking up additional class time. Could an online review and assessment tool be effective in addressing this problem?

Branoff and Totten (2006), in "Online Learning in Engineering Graphics Courses: Research, Tools, and Best Practices", had some interesting results with a 400-level 3-D CAD course. In spring 2004, students read the assignments, watched voiced-over slides streamed online, and took midterm and final exams. The following year, online quizzes were added for each reading assignment. The change in student performance between 2004 and 2005 was startling. The mean midterm exam score increased from 84 to 91 and the mean final exam score increased from 69 to 97, suggesting that following up online activity with immediate online assessment has a significant impact on effectiveness.

Branoff (2007) looked at the effectiveness of requiring students in an introductory graphics

course to take an online assessment of the week's reading assignment before coming to class for additional instruction. His analysis indicated that there was no relationship between student online assessment scores and homework or midterm exam scores. And yet on a post-assessment survey student responses were overwhelmingly positive regarding the value of online assessment helping them prepare for class and prepare for the midterm. They were also unanimous in their agreement that the faculty should continue to use the online assessment. The vast majority indicated that without the online assessment they would probably look at the chapters only when studying for exams. If the online assessment has the effect of getting the students to spend more time reading the book, then it seems worthwhile.

In addition to online assessment and voiced-over content presentations, some Engineering Design Graphics faculty members have begun supplementing their face-to-face student time with online voiced-over software demonstrations and sketching examples. Branoff and Wiebe (2008) used these techniques in a hybrid version of a foundations of graphics course. They ran three sections of the hybrid version and compared the final exam scores to the scores from fourteen face-to-face sections. They found that there was virtually no difference between the final exam scores in the hybrid and the standard face-to-face sections. Student surveys also showed that the students preferred the hybrid version over the face-to-face version by a margin of more than two to one. The results were so successful that in the spring 2009 semester they plan to offer only hybrid sections of this course along with a pilot for a completely online version.

The goal of the work described in this paper is to develop online presentations that can be used primarily to reinforce and review the material covered earlier in the course related to working drawings. Students will be required to pass an online assessment before they can turn in their final design project reports. This requirement will hopefully result in higher quality working drawings in their final reports.

## ONLINE MATERIAL OVERVIEW

In the first semester design course at Daniel Webster College students are required to submit hand-sketches that cover a variety of topics as well as submit drawings of increasing levels of detail created in SolidWorks. After regular assignments have been completed in the first half of the semester, students then begin work on a CDIO design project. A large portion of the work for this project involves creating working and assembly drawings. In order to reinforce the principles covered in the assignments during the first half of the semester, a review module was added to supplement the in-class material.

Part of the difference between the drawing assignments completed early in the semester and the working drawings that students create for their projects is that the requirements for the regular drawing assignments are clearly specified, whereas for their design projects they must create their own solutions and make their own decisions in selecting and laying out working drawings. This difference of format seems to create a stumbling block for students, causing them to miss even some basic aspects of drawings. By adding this additional review material and assessment, students may be better prepared to apply the concepts they learned in assignments to the drawings they create for their projects.

The review module for drawings is organized into four topics: Basic Drawing Set-up, Baseline Dimensioning, Contour Dimensioning, and Assembly Drawings (Figure 1). A combination of videos, online assessments, and functional examples of each topic was used to cover and assess the proficiency of each student in the various areas related to drawings. Each topic begins with a diagnostic assessment, which is followed by review videos and presentations. The material for each topic remains available for student reference during later assignments and projects. Finally, a follow-up assessment becomes available if the student does not pass the diagnostic assessment (Figure 2).

Use of a course management tool like Angel (Angel Homepage, n.d.) allows the review mod-

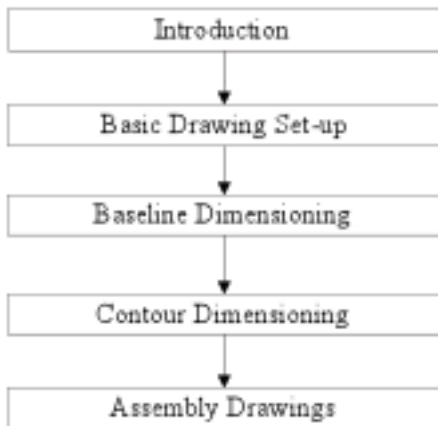

Figure 1. Flowchart of Review Module.

ule to be organized in such a way as to guide students through the material in a logical order. Students are introduced to the module with a video explaining the purpose, process, and topics to be covered. The first topic is then made available to the students, and they are only able to access the diagnostic assessment in that first topic. When the student submits the assessment, all review material becomes available. As the student passes the diagnostic, or passes the follow-up assessment, the next topic then becomes available (Figure 2). This sequence allows the online portion of the material to be organized in a similar fashion to face-to-face presentation of material.

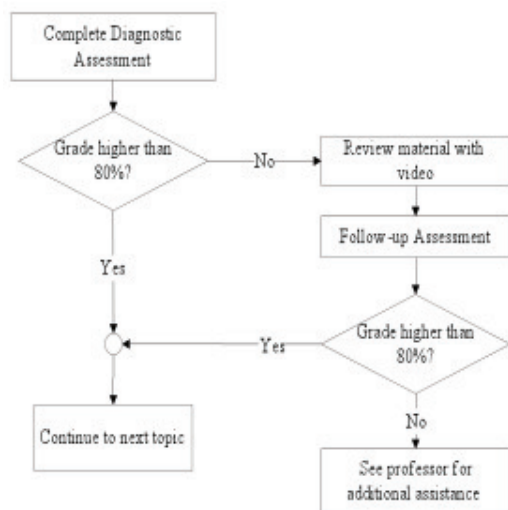

Figure 2. Organization of Individual Topics.

The purpose of the diagnostic assessment for each topic is to identify areas of proficiency for all students so they are not bored with information and additional assessments in areas in which they are already capable. The grade of the diagnostic exam will prompt instructions to the student to either move on to the next topic or complete review material. Students who are not proficient in a subject matter will be directed to view a short review video about the topic. After the review video has been watched, examples related to the topic and another assessment are made available, allowing the students to study and assess their understanding. If a student is unsuccessful in passing the follow-up assessment, he or she will be directed to seek help from the instructor of the course.

Assessments are composed of multiple choice, true/false, and matching questions. Both the diagnostic and follow-up assessments contain ten questions, and the diagnostic and follow-up assessments have different questions. The feature of reviewing assessment submissions is disabled so students can see their scores but cannot review their submissions. The assessments are also randomly arranged. There are no time limits on the assessments. These features encourage the student to take the time to consider the answers and to re-take the follow-up assessment when needed. Some questions from the Setting Up Drawings question bank are shown below (Figure 3).

2. Match the following:

A. Center Lines
B. Center Marks
C. Hidden Lines
D. Isometric View

- Dashed lines that are visible in front/right/top views to indicate edges behind the visible surface
- Dashed line that extends 1/8" past edge of feature that indicates a circular feature in the rectangular view
- Shaded, half scale view
- Cross with 1/8" lines that indicate a circular hole in the circular view

3. The isometric view should be shaded.

A) True

B) False

4. What are the standard three views normally imported into a drawing?

A) Front, Bottom, Left

B) Front, Top, Left

C) Front, Top, Right

D) Front, Bottom, Right

Figure 3. Setting Up Drawings Assessment Example.

Each topic in the review module focuses on a different aspect of working and assembly draw-

ings. Basic Drawing Set-up includes concepts such as first angle and third angle projection, hidden lines, center marks, center lines, scale, and general aesthetics of a drawing. Because they are a means of technical communication, drawings must be functional, but as graphics they should also be well arranged. As students proceed to Baseline Dimensioning, the functionality of the drawing is emphasized, covering reference points, when to use occasional chain dimensions to emphasize critical dimensions, and the best way to complete drawings for use in a machine shop (Figure 4).

Contour Dimensioning moves past 2-D parts such as plates to cover notches, arcs, and holes in great detail (Figure 5). In addition to a presentation outlining a number of rules that apply to contour dimensioning, examples are shown for a variety of contours to help students see the rules put to use. While holes are dimensioned in Baseline Dimensioning, greater emphasis is placed on understanding hole callouts in the Contour Dimensioning review material. Finally, students review the concepts of exploded views, and Bills of Materials in the Assembly Drawing review material.

Students continue through the material after passing an assessment for the first topic. Each new topic becomes available upon the completion of the previous material. All materials remain available for students who wish to revisit material at

later dates. Online course management programs like Angel facilitate this process of guiding students through material in an acceptable order while allowing them to complete the material outside of class on their own time. In this way material is accessible to students at all times, unlike presentations in class.

Material from the text book and examples of parts used in other assignments for the course are used in videos and materials for each topic since students are familiar with and have access to both. Videos highlight the main points of the topic, go through the process of preparing a drawing with emphasis in the main points of the topic, and conclude by summarizing the points. Both PowerPoint slides and SolidWorks examples are used in the videos to combine bulleted points, pictures of good and bad examples, and the actual process of creating the drawing to thoroughly cover each topic.

At the end of each topic, a brief summary of the points is available as well as an explanation of frequent mistakes on working drawings. These two summaries allow students to quickly refer to the main points without necessarily reviewing all of the details and examples associated with the topic. Students are encouraged to refer to this module when they start working on drawings for their design projects.

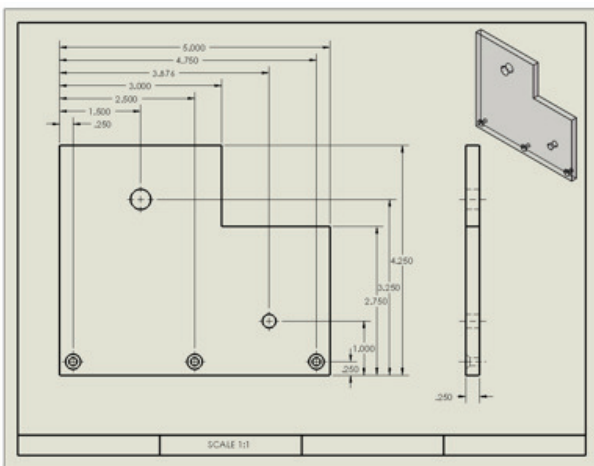

Figure 4. Baseline Dimensioning.

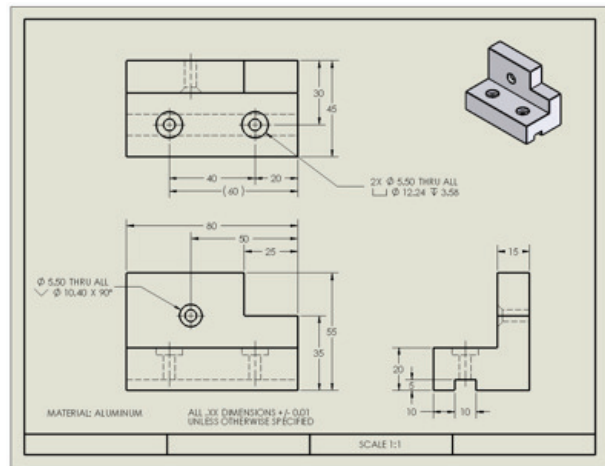

Figure 5. Example of Contour Dimensioning.

**ASSESSMENT RUBRIC**

The School of Engineering has maintained scanned copies of design project reports for the fall 2006 and 2007 semesters. The working drawing assessment rubric (Figure 6) shown below was used to evaluate the working drawings for these semesters so that a comparison could be made with the project working drawings submitted for the fall 2008 semester.

The following scale was used:

1. Incorrect in virtually all drawings
2. Incorrect in many drawings
3. Incorrect in only a few drawings
4. Correct in all drawings

**RESULTS AND DISCUSSION**

The data from the 2006 and 2007 design projects, which had no review material, were combined and compared to the data from 2008, which did. Seventeen groups from 2006 and 2007 (combined), and eleven groups from 2008 were scored. The averages of each attribute score are shown graphically in Figure 7. It can be seen that most of the attributes either improved or stayed approximately the same in 2008 from the previous two years. Statistical significance of the changes was not calculated due to the small sample size. Dramatic improvements were observed in Bill of Materials, Tolerances, and Shaded Isometric Views. These three attributes improved by about 1.5 points each. The exception to this trend is Thread Notes, for which the average score for 2008 was slightly lower than the previous two years.

In addition to the averages, the distribution of scores within an attribute demonstrates the improvement seen in many attributes after the implementation of the review module. An example of this is Contour Dimensioning, the distribution of which is shown in Figure 8. While the average improved from around 2.5 to about 3.0, the distribution improved such that there were no teams

scoring 1, fewer teams by percentage scoring 2, and more teams by percentage scoring 3 and 4.

There were several factors that may have caused some attributes to stay relatively unchanged. This

Attribute	1	2	3	4
Line Weights				
Material Specified				
Thread Notes				
Hole Notes (Except Thread Notes)				
Tolerances Specified				
Dimensions Placed in Correct View According to Contour Dimensioning Principles				
Appropriate Scale and Placement of Views on Sheet				
Extension Line Offsets				
Lengths for Hidden Lines, Center Marks, and Center Lines				
Dimension Line Distance from Part				
Baseline Dimensioning				
Dimensions Lined Up and Grouped Logically				
No Superfluous Dimensions				
No Missing Dimensions				
Shaded Isometric				
Assembly is Exploded in a Logical Manner				
Exploded Assembly Trail Lines				
Exploded Assembly Balloon Placement				
Bill of Materials Complete Including Unit and Extended Weights and Costs along with Totals				
Upper Case Text of Appropriate Size Used in Title Blocks and BOMs				

Figure 6. Assessment Rubric.



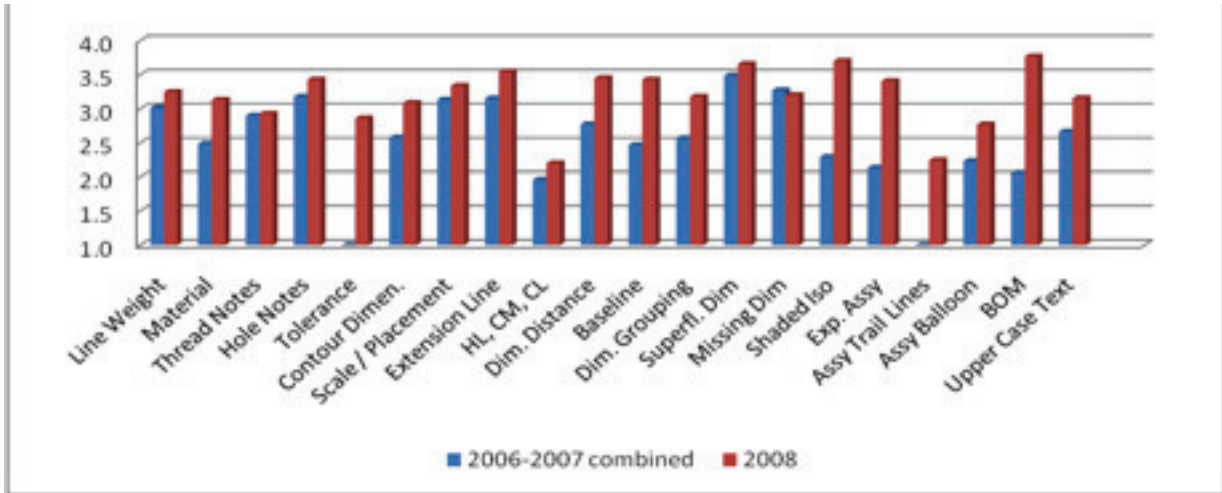

Figure 7. Attribute Averages.

was the initial usage of the module, and due to time constraints there was no opportunity to pilot test and revise the module before implementation in the fall 2008 semester. Second, it seems that some topics should receive greater emphasis in the review sections. Finally, some specific dimensioning concepts were not covered in the review module. While contour dimensioning was covered in detail, the examples may not have sufficiently covered the specific dimensioning related to the students' projects. For example, the technique for dimensioning keyways would benefit the students, since the final project uses keyways a number of times in the design.

In the future the module will be employed earlier in the semester, which may make it more effective. All teams are required to submit initial drafts of their working drawings for review, followed by a revised set of working drawings submitted with the final report. In fall 2008, the review module

was available before the final design reports were submitted but was not ready for student use before the drafts were due; if students complete the review module before creating their draft working drawings then it is likely that the draft quality will improve. Due to the end-of-semester crunch in fall 2008 it was likely that some teams did not have time to revise their working drawings between draft and final submissions. Requiring students to complete the module prior to submitting their initial drafts should make the review more beneficial.

## CONCLUSIONS

Upon analysis of the data, it appears that the review module helped to improve the quality of working drawings submitted by freshman in their final report for Engineering Design I in a number of attributes. Contour Dimensioning, Baseline Dimensioning, and basic Drawing Setup seemed to be better than in previous years. However, the

improvement was not consistent across all the drawing attributes evaluated. It is likely that implementation earlier in the semester and more examples for the topics that didn't improve would help students create higher quality working drawings.

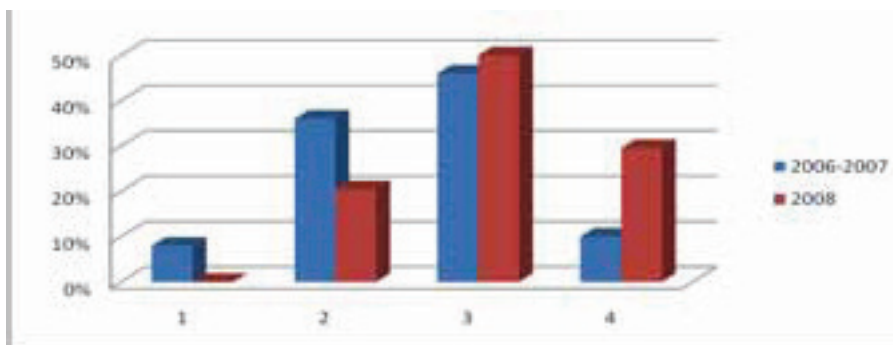

Figure 8. Distribution of Scores for Contour Dimensioning.

This module will continue to be used at Daniel Webster College and collaboration with other colleges should help improve its quality and provide data to further evaluate its effectiveness. Upon request, the review material and assessments will be made available to faculty interested in providing feedback or implementing the module.

## REFERENCES

- Branoff, T. J. (2007). Do Online Formative Questioning Strategies Correlate with End-of-Course Evaluations? 61st Annual Midyear Conference of the Engineering Design Graphics Division of the American Society for Engineering Education.
- Branoff, T. J., & Totten, R. A. (2006). Online Learning in Engineering Graphics Courses: Research, Tools, and Best Practices. 2006 American Society for Engineering Education Southeast Section Conference.
- Branoff, T. J., & Wiebe, E. (2008). Face-to-Face, Hybrid, or Online?: Issues Faculty Face Redesigning an Introductory Engineering Graphics Course. 2008 American Society for Engineering Education Annual Conference.
- Homepage. (n.d.). Retrieved October 18, 2008, from CDIO Initiative: [www.cdio.org](http://www.cdio.org)
- Homepage. (n.d.). Retrieved from Blackboard-Angel: [www.angelllearning.com](http://www.angelllearning.com)

