

Spring 2009

Cam Design Projects in an Advanced CAD Course for Mechanical Engineers

H. K. Ault, Ph.D.
Worcester Polytechnic Institute

ABSTRACT

The objective of this paper is to present applications of solid modeling aimed at modeling of complex geometries such as splines and blended surfaces in advanced CAD courses. These projects, in CAD-based Mechanical Engineering courses, are focused on the use of the CAD system to solve design problems for applications in machine design, namely the geometric and mechanical design of cam mechanisms.

Introduction

Most introductory CAD courses build solid modeling skills using basic shapes such as simple extrusions and revolved features. In advanced CAD courses, skills for modeling complex geometries that require the use of blended surfaces such as skins and sweeps are introduced using arbitrary shapes or parts that are designed primarily for aesthetics. Various applications for the use of complex geometries including automotive, aerospace and marine craft design have been used as the basis for a variety of student projects (Helbling et al., 2007; Leake, 2004; Leonhardt and O'Charoen, 2006; Wronnecki, 2007).

To enhance the students' understanding of more advanced CAD modeling and surface design, it is desirable to design shapes such as spline contours and ruled surfaces based on the engineering requirements of the parts, not just aesthetics. Students must also be able to analyze geometric properties such as slope, surface normals, and radius of curvature, which may have a significant impact on performance of the part.

In the area of machine design, complex shapes are required for proper dynamic performance of cam surfaces. These surfaces encompass the use

of spline contours for both extruded and blended surfaces. This paper will explore the use of cam design as an example of engineering applications of geometric design and analysis in advanced undergraduate and graduate level CAD courses.

Course Descriptions

Mechanical engineering electives at WPI are grouped into "concentrations". Nearly half of the mechanical engineering undergraduate students at WPI select a concentration in mechanical design. This concentration includes introductory and advanced courses in CAD, design methodology, kinematics, machine design, dynamics of machinery, system dynamics and robotics.

The Introductory CAD course covers basic solid modeling and drawings; one lab is used to introduce simple sweeps and blends, with no significant discussion of theory. Splines are not discussed. The Advanced CAD course is offered to juniors and seniors. The course objectives are not only to build the students' modeling skills, but to do so in the context of realistic engineering design projects.

In addition to the undergraduate courses, WPI also offers a graduate level course in Geo-



metric Modeling and Design. The objectives of this course are to present the mathematical foundations of geometric modeling, in the context of mechanical engineering design applications. The course is populated by both full and part-time graduate students as well as some senior undergraduates.

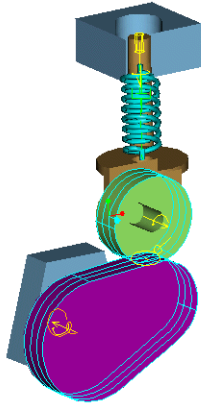

Figure 1. *ProEngineer Cam Tutorial (PTC, 2007)*

Cam Design Projects

Cam mechanisms often require the use of complex geometries to describe the shape of the cam surface. Cams of increasing geometric complexity are selected as the basis for design projects in advanced undergraduate and graduate level CAD-based design courses.

Advanced CAD for Undergraduates

Most students in the advanced CAD course will have had or are concurrently enrolled in the kinematics course. Thus, it is assumed that they will be familiar with the design requirements for typical cam motion programs. Furthermore, the students can use cam design software Dynacam that accompanies their kinematics text (Norton, 2007) to design any desired cam contour, based on dynamic performance criteria.

A simple cam mechanism modeling tutorial is presented first (PTC, 2007). The cam mechanism is shown in Figure 1. Through this tutorial, students use a simple cam contour (lines and

arcs) to generate kinematic data such as follower position, velocity and acceleration, as well as dynamic reaction forces in the spring and damper, and torque on the servo-motor.

After the analysis of this simple geometry, the students can import a more complex, spline-based cam contour from Dynacam and repeat the analysis. Cam performance characteristics such as pressure angle can be calculated using Dynacam and compared to the direction of forces calculated in ProEngineer. The radius of curvature must be larger than the radius of the roller follower in order to avoid undercutting of the cam during manufacturing. This geometric property can also be measured in the CAD system.

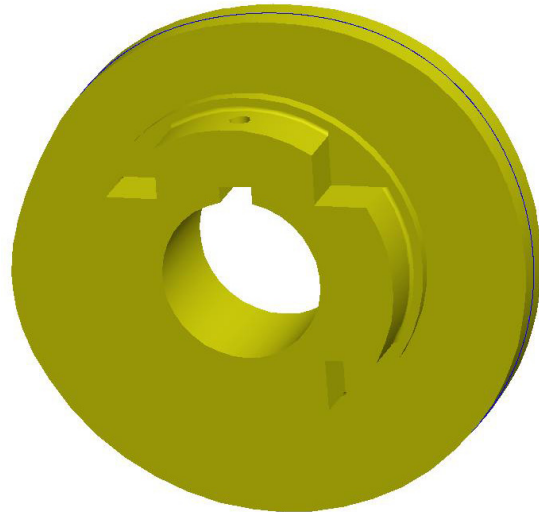

Figure 2. *Plate cam made with spline contour (Yamartino, 2004)*

CAD systems with variational modeling capabilities can also be used for optimization. In this example, the design problem involves a simple eccentric cam as shown in Figure 3. The objective of the project is to minimize the contact forces between the cam and follower for a given cam radius (r), cam speed (ω), lift (a), and spring constant. The model includes material properties and gravity. All of the dimensions shown in figure 3 are used as design variables ($d1-d3$, $h1-h5$, e), with some required relationships between variables and limits on size. These relationships

must be built into the CAD model. The students perform a sensitivity study for each of the design variables and use the results for the optimization.

Graduate Level CAD Projects

Globoidal cams are used in indexing machines and pick-and-place mechanisms where packaging constraints prevent the use of simpler plate cams. An example of a globoidal indexing cam is shown in Figure 4.



Figure 4. Globoidal cam in indexing machine (CMB Engineering, 2007)

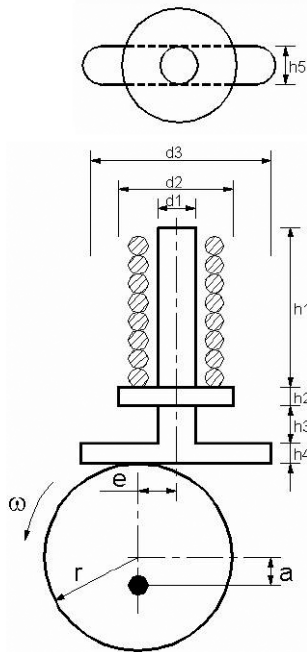

Figure 3. Cam Optimization Problem (Moon, 2005)

Typically, the cam surface is modeled as a ruled surface, as described by Norton (2008). The geometric parameters are shown in Figure 5. The section curves for the ruled surface are space curves, not 2D. Generating the space curves and sweeping the surface present a significant modeling challenge. Once the surface is generated, the geometric model can be interrogated to obtain measures of the local radius of curvature of the cam surface. A mechanism model can be used to evaluate pressure angles; optimization studies can be performed by varying the cam diameter, follower arm dimensions, offset or other geometric parameters.

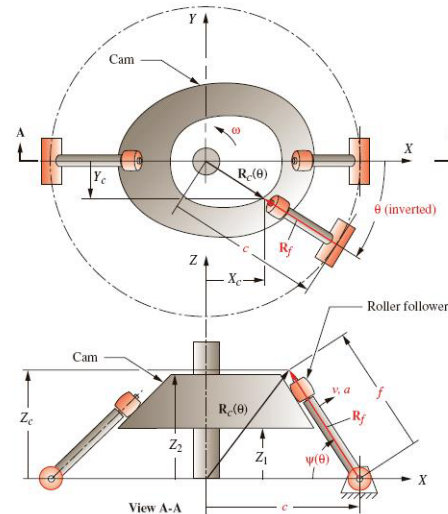

Figure 5. Globoidal Cam (Norton, 2008).

Conclusion

Cam mechanisms can be used as the basis for design projects in advanced CAD courses to study complex geometric shapes. The graduate level projects are similar to the undergraduate projects, but with more complex geometry.

References

Ault, H.K. and Yamartino, D.E. (2004). ES 3323 C04 Cam Lab. Worcester Polytechnic Institute, ES 3323 Advanced Computer Aided Design.

CMB Engineering, (2007). Soudronic Welder Gearboxes. http://www.canlinespares.co.uk/refurb_machines_sub_4.php, accessed 07 October 2007.



- 
- Helbling, J., Marriott, D., and Gally, T. (2007). Applied computer aided design using aerospace vehicles for sophomore level students. *ASEE Annual Conference Proceedings*, #2701.
- Leake, J.M. (2004). Development of an advanced course in computer-aided design, analysis and prototyping. *ASEE, Annual Conference Proceedings*.
- Leonhardt, E. and O'Charoen, V. (2006). Paddling for a record – Building a kayak to improve CAD surface modeling and composite construction skills. *ASEE Annual Conference Proceedings*, #2151.
- Moon, Y-M. (2005). ES3323 Cam Optimization. Worcester Polytechnic Institute. ES 3323 Advanced Computer Aided Design.
- Norton, R. (2007). *Design of machinery*. McGraw-Hill.
- Norton, R. (2008). Cam Design and Manufacturing Handbook. *Industrial Press*. 2nd edition, in press.
- Parametric Technologies Corporation. (2007). Mechanism design tutorial 3: Creating an oscillating Cam. ProE Wildfire 2 help files.
- Wronecki, J. (2007). Surface modeling techniques for automotive and product design. *ASEE, Annual Conference Proceedings*, #1163.
- Yamartino, D. (2004). Creating Cams in Pro/Engineer Wildfire Using *DYNACAM*. Worcester Polytechnic Institute.