



PRIFYSGOL
BANGOR
UNIVERSITY

Translanguaging as a strategy to boost human learning:

An event-related potential (ERP)
investigation.

Doctoral dissertation presented by:

Ms Anna M. Beres

Thesis submitted to the School of Psychology, Bangor University, in fulfillment
of the requirements for the degree of Doctor of Philosophy

Page intentionally left blank

Acknowledgements

There are some people who have been too amazing not to deserve a few special words. I would like to thank **S.**, for all the help and support over the last couple of years, and for all those fun Curry nights ;) **A.** – for answering all of my questions, giving advice, and breaking the dull weeks of writing-up with some fun Skype chats. Also my gratitude goes to **O.** and **W.**, for always being there for me, their constant support no matter what, advice, friendship, and the fabulous game and Abba nights ;) I would also like to thank **C.**, for her advice on anything from reading through writing to cooking and baking, and for being such a wonderful friend for so many years now. Finally, **H.** – for all the fun we've had drinking wine and travelling together; I hope there are more trips awaiting us in the future! I feel immensely proud and privileged to call all of those people my friends.

I would also like to thank all the participants who volunteered their time and made this thesis possible. My sincere gratitude goes to everyone at the Bilingual Mind Research group in Vitoria, for all the help and advice they gave me.

Finally, eternal gratitude and love goes to my wonderful family. Without them, none of this would have been possible. I will be forever in debt for all the love and support they have given me over the years. My love also goes to my sister **Basia** and the two most wonderful boys in the world, **Kai** and **Niko**, who live in the world of translanguaging.

I dedicate this thesis to my parents, who never gave me any idea that I couldn't do whatever I wanted to do, or be whomever I wanted to be. I will always be grateful for their never-fading enthusiasm, support, patience, and endless love.

**‘If you talk to a man in a
language he understands,
that goes to his head.’**

[Nelson Mandela]

Page intentionally left blank

Translanguaging as a strategy to boost human learning: An event-related potential (ERP) investigation.

Contents

Summary	14
Chapter 1 Let’s talk it over. General introduction and thesis overview	16
1. Aims of the thesis and research questions.....	19
2. Structure of the thesis.....	21
3. Dissemination of findings.....	22
Chapter 2 An overview of Translanguaging: 20 years of giving voice to those who do not speak	25
Abstract.....	26
1. General overview.....	27
2. Historical background.....	28
2.1 Turn of the 20 th century.....	28
2.2 Mid-20 th century.....	28
2.3 Turn of the 21 st century and the ‘B’ word.....	29
2.3.1 The case of Wales in the UK.....	29
2.3.2 The case of the US.....	30
3. Developments of Translanguaging.....	31
3.1 Origins of Translanguaging.....	31
3.2 Further research in Wales.....	32
3.3 A global take on Translanguaging.....	32
3.4 Further international research on Translanguaging.....	33
4. General discussion of Translanguaging.....	36
5. Current research on Translanguaging.....	39
5.1 Translanguaging in the community.....	39
5.2 Neural underpinnings of Translanguaging.....	40

6. The future of Translanguaging.....	41
Chapter 3 Time is of the essence. Electroencephalography (EEG) and event-related brain potentials (ERPs).....	43
1. Short introduction.....	45
2. Event-related brain potentials (ERPs).....	46
2.1 How does it work?.....	47
2.2 Use of EEG in the present thesis.....	49
2.3 ERP components.....	50
2.4 Components most commonly implicated in language research.....	51
2.4.1 What do you <i>mean</i> ? The N400 component.....	51
2.4.2 The preceding context matters – the P600 component.....	54
2.4.3 Left anterior negativity (LAN).....	55
2.4.4 Mismatch negativity (MMN).....	55
3. Pros and cons of using ERPs in language research.....	57
3.1 Advantages.....	57
3.2 Disadvantages.....	58
4. Conclusions.....	60
Chapter 4 Translanguaging: A new strategy to boost human learning.....	62
Abstract.....	63
Introduction.....	64
Methods.....	67
Results.....	77
Discussion.....	89
Conclusion.....	93
Chapter 5 Bilingual word recognition: An ERP study with Welsh-English bilinguals.....	94
Abstract.....	95
Introduction.....	96

1. On the issue of language-switching effects.....	96
2. On the issue of automaticity of semantic priming.....	100
2.1 Masked priming studies in monolinguals and bilinguals.....	101
2.2 Priming experiments with visible primes.....	102
3. On the masked <i>versus</i> visible primes – does it really matter?.....	103
4. On the issue of language criteria in bilingual studies.....	103
5. On the issue of automatic semantic priming in early, native-like bilinguals.....	104
6. The present study.....	105
Methods.....	106
Results.....	110
Discussion.....	115
1. The automaticity of semantic priming.....	115
2. The effects of language-switching.....	118
3. Handling of the data.....	119
Conclusion.....	120

Chapter 6 | The electrophysiology of comprehension and production of words and pictures in Basque-Spanish bilinguals. An ERP investigation.....

Abstract.....	122
Introduction.....	123
1. How people produce words.....	123
2. Use of ERPs in language production research.....	126
3. The present study.....	129
Methods.....	130
Results.....	135
Discussion.....	143
Conclusion.....	148

Chapter 7 | General discussion.....

1. Summary of the main results.....	151
-------------------------------------	-----

2. Review of the key findings.....	153
3. Methodological considerations.....	158
3.1 Bilingual participants' language skills.....	158
3.2 Behavioural effects (and the lack of thereof) in ERP studies.....	159
4. Practical implications and limitations.....	160
5. Ideas for future research.....	161
6. Concluding remarks.....	162
References.....	164

Summary

Bilingual education has witnessed a major shift towards mixing two languages in the classroom. However, adequate methods taking into account the needs of today's highly multicultural world require scientific testing. Translanguaging is a method of learning in which students produce an output of their learning in a language different to that of instruction. So far, insights into the potential benefits of this method have been exclusively qualitative. The aim of this thesis was to quantify the benefits of translanguaging for new knowledge acquisition. In the main experiment (Chapter 4) I have found neuroscientific evidence for facilitated access to existing semantic representations for items used in learning mediated by translanguaging as compared to control items presented in a monolingual learning context. Participants were tested using a picture-picture priming paradigm after a learning phase involving either English or a code-switch between English and Welsh simultaneous with a switch between reading and speaking. Beyond the expected effect of semantic relatedness on the mean N400 amplitude, well known to index semantic processing effort (Kutas and Hillyard, 1980), a striking main effect of translanguaging on the same N400 was found, suggesting that relevant semantic representations had become selectively more accessible in long-term memory. Moreover, this effect could still be measured 2 to 4 weeks later without participant training. In chapters 5 and 6, I have set out to test the two components of translanguaging separately in order to determine the contribution to the overall effect of code-switching on one hand and comprehension-to-production on another. Chapter 5 focuses on the automaticity of semantic priming and the potential impact of code-switching on the N400 in Welsh-English bilinguals. Chapter 6 focuses on the effects of the comprehension-to-production switch on the N400 in Basque-Spanish bilinguals.

Page intentionally left blank

Chapter 1

Let's talk it over:

General introduction and thesis overview.

Bilingualism is not a new phenomenon; however the way it is perceived by the society has been variable over time. Bilingual education was seen as desirable and prestigious for hundreds of years, up until the 15th century, when the changing socio-economical perspective and the development of printing press prompted the drive to uniform language used and make education homogenous. This trend has prevailed until the turn of the 20th century, when leaders have realised the need to educate everyone in the society, regardless of their social or linguistic background. This has given a rise to decades of experimenting with bilingual education, and introducing new programmes. However, the overarching aim remained the same in the majority of the approaches: to educate children from various linguistic backgrounds, but with the hope of them mastering the ‘target’ language of the school and society and then facilitating essentially monolingual education from that point onwards. Other programmes, which aimed at gaining proficiency in both languages, kept them strictly separate, dedicating particular lessons, teachers, or even days of the week to one language or the other.

However, towards the end of the 20th century, some schools have begun to experiment with the concurrent use of two languages within the same lesson. This method was first coined as the Welsh word *trawsieithu* by Cen Williams (1994a) to describe a teaching strategy in which students receive information in one language and produce an output of their learning in another. It has since been renamed as *translanguaging*, and popularised globally by international scholars and educators, most notably Colin Baker in the U.K. and Ofelia García in the USA. Despite translanguaging being now widely accepted as the most appropriate approach to bilingual education, so far there has been no quantitative evidence provided on the effects of this teaching method.

In terms of the practical issues around translanguaging, they are still being discovered and the best way to incorporate translanguaging into a daily classroom is an ever-changing and still very much developing concept. There is no question that using such flexible approach comes with many challenges, especially for the teachers, who might not always be familiar with languages spoken by their students, and for the children who might have different skill levels of different languages. One thing is very clear,

however: in order for children to learn, they must understand the concept that is being taught and must be able to manipulate the information. If, therefore, they do not understand the language of instruction, they cannot possibly acquire new knowledge and use it effectively. Translanguaging is a strategy that makes this learning possible, while at the same time it allows for the development of language skills. Collaborative work is crucial, especially in the classroom with children from different linguistic backgrounds, who can work together in order to figure out a solution to a given task. They learn not only a new language along the way, but also gain new perspectives, expand their thinking and increase their understanding.

In this thesis, I have attempted to find neuroscientific bases of translanguaging and to quantify its potential as a teaching strategy in acquiring new information. The present work begins with an overview of the translanguaging research so far, followed by an overview of electroencephalography (EEG) and event-related brain potentials (ERPs) as the method of choice employed in the present research.

The experimental work is described in 3 separate chapters. Firstly (Chapter 4), I concentrate on the longitudinal study of translanguaging, in which after the completion of a novel-object learning task, participants were tested on the efficiency of their semantic integration using the ERPs. Testing was conducted at two time points – straight after initial learning and up to a month later. In this chapter, I suggest that what makes translanguaging a successful method of learning is the concurrent use of both language and mode switch. The results of this experiment paved way for the further two studies conducted as part of this thesis: a study on language-switching, and another study on modality-cross (Please note that in this thesis, terms: *modality-cross*, *modality-switch*, *mode-switch* are used interchangeably, and refer to transferring from comprehension to production). Those 2 further experiments were designed in order to disentangle the two ‘pillars’ essential for translanguaging. In Chapter 5, the focus is on Welsh-English early, balanced bilingual adults’ processing of language switch, whereas Chapter 6 focuses on how early Basque-Spanish bilinguals process the modality-switch in both pictures and words. In all of the studies, the focus has been the N400

component, as it is known to index semantic integration effort. In Chapter 4, the interesting differences were found within the N400 window, and therefore both Chapter 5 and 6 aimed to investigate language-switching and modality-switching separately and their individual impact on the N400. All the experimental work in the present thesis uses ERPs as the method of choice. Additionally, behavioural measures, such as reaction times and accuracy, were collected when it was appropriate to do so.

As a result of the set of experiments presented in this thesis, I propose a definition of translanguaging as a complex process, which entails both language and mode switch—that is, a shift between comprehension in one language at input (reading, listening) and production in another language at output (writing, speaking). Moreover, as the evidence presented here shows, translanguaging cannot be reduced to simply one of those components, and it is an elaborate interaction of the two that makes it a successful strategy for new knowledge acquisition.

Overall, I believe the work presented here approaches translanguaging from a novel perspective and provides a unique neuroscientific take on this teaching and learning method. Moreover, the experiments included in this thesis constitute the first ever quantitative evidence that highlights the effectiveness of translanguaging.

1. Aims of the thesis and research questions

The aim of this thesis is to explore translanguaging as a potential teaching and learning strategy. As no one has done any quantitative research on the topic before, this work is considered as just the beginning of the road to bilingually boosted education. It has its advantages and disadvantages. The advantages are the unquestionable novelty of such research, and the potential impact it might have on the way bilingual education is seen in research, educational, and policy settings. The disadvantages, however, are that this research is just the first, very small step taken towards understanding the potential of translanguaging. This step cannot possibly answer all the questions and provide clear-cut answers to how bilingual education should be approached. This thesis answers some

initial questions about translanguaging, but opens up many more, which are essential to investigate if we are to truly understand the mechanisms involved in translanguaging. Therefore, future research on the topic is essential before a real change in the way we approach bilingual education can happen.

1.1 This thesis aimed to address the following research questions:

- 1.1.1** Mixing two languages in the same learning context is often considered detrimental. This stems from people's fear that such mixing can introduce confusion and therefore impact negatively on learning. The main question this thesis aimed to answer was whether this view is true. Precisely, the goal was to investigate whether learning through translanguaging, as opposed to monolingually, has any impact on people's learning?
- 1.1.2** Is such impact negative, neutral, or perhaps positive?
- 1.1.3** Since translanguaging involves simultaneous language and modality (i.e., going from comprehension to production) switch, what are the individual contributions of those components to the overall effect of translanguaging?
- 1.1.4** Is translanguaging just a fancy word for code-switching?
- 1.1.5** Are there any long-term implications of learning through translanguaging? Are they different from those based on monolingual learning?
- 1.1.6** Finally, in qualitative and observational studies, translanguaging has been seen as a great strategy for learning. Will it be confirmed in carefully-designed, quantitative research?

2. Structure of the thesis

2.1 Chapter 1 provides an overview of the present research, the research questions that this thesis aimed to answer, and the dissemination of the findings.

2.2 Chapter 2 provides a review of all the literature concerning translanguaging to date, discusses the developments of translanguaging over the last 2 decades, and ideas for future research.

2.3 Chapter 3 discusses the methodology used in the present research.

2.4 Chapter 4 describes a longitudinal study of translanguaging in Welsh-English adult bilinguals.

2.5 Chapter 5 investigates language-switching as one of the main components ('pillars') of translanguaging in Welsh-English adult bilinguals.

2.6 Chapter 6 investigates modality-cross, that is going from comprehension to production, in Basque-Spanish adult bilinguals as another main component of translanguaging.

2.7 Chapter 7 summarises and discusses the results of all the findings together and examines the answers to the research questions set out in the present chapter (Chapter 1).

3. Dissemination of findings

Chapter 2 has been peer-reviewed and published as **Beres, A. M.** (2015). *An overview of translanguaging: 20 years of 'giving voice to those who do not speak.'* *Translation and Translanguaging in Multilingual Contexts, 1*, 103-118. doi: 10.1075/ttmc.1.1.05ber

Chapter 5 has been submitted for publication and is currently under review.

Chapter 6 has been possible thanks to Santander Special Mobility Grant (Student) and the PsyPag Study Visit Grant, which I have received. This has allowed me to spend 3 months at the University of the Basque Country in the 'Bilingual Mind' research group (under the directorship of Prof Itziar Laka), where I collected all the data necessary for that study. This chapter is currently in preparation for publication.

The work included in this thesis has been a subject to **press coverage**, with the following articles in the media:

- Cognitive Neuroscience Society (CNS) website:
http://www.cogneurosociety.org/bilingualmind_beres_guest/
- LiveScience website:
<http://www.livescience.com/47068-learning-languages-two-at-a-time.html>
- Yahoo News:
<http://news.yahoo.com/unleashing-power-bilingual-mind-op-ed-192810199.html>

Additionally, I have been selected to present this work at the **SoapBox Science** event in Swansea in June 2015. Soapbox Science is a novel public outreach platform for promoting women scientists and the science they do (see www.soapboxscience.org for more information).

I have been awarded a number of grants and awards, which have enabled me to complete this work and present it at different conferences, including:

- **Merit Award** for the highest-ranked abstract submitted to the *Society for the Neurobiology of Language 2013 Annual Meeting*, awarded by the Society;

- **Travel Award** to present my work at the *Society for the Neurobiology of Language 2013 Annual Meeting*, awarded by the Society;
- **Grindley Travel Award** from the *Experimental Psychology Society (EPS)*;
- **PsyPag Study Visit Award** to visit University of the Basque Country for 3 months;
- **Santander Special Mobility Grant** to visit University of the Basque Country for 3 months.

Additionally, a number of conference presentations have been made to date based on findings from the data included in this thesis:

April 2015:

- An oral presentation on the findings from Chapter 6, entitled ‘The electrophysiology of comprehension and production of words and pictures in Basque-Spanish bilinguals: An ERP study’ at the **Neuronus Neuroscience Forum** (Krakow, Poland);
- A poster presentation on the findings from Chapters 4-6, entitled ‘Education and Neuroscience: When more difficult is better for learning’ at the **Neuronus Neuroscience Forum** (Krakow, Poland).

August 2014:

- A poster presentation based on findings from Chapters 4-6, entitled ‘Examining the pillars of Translanguaging’ at the **Society for the Neurobiology of Language (SNL) Annual Meeting** (Amsterdam, The Netherlands).

April 2014:

- An oral presentation entitled ‘Translanguaging: a way to facilitate new knowledge acquisition’ at the **Neuronus Neuroscience Forum** (Krakow, Poland).

January 2014:

- A poster presentation entitled ‘Translanguaging: Boosting the acquisition of new knowledge using bilingualism’ at the **Alpine Brain Imaging Meeting (ABIM)** (Champéry, Switzerland).

November 2013:

- An oral presentation entitled ‘Translanguaging: Boosting the acquisition of new knowledge using bilingualism’ at the **British Psychological Society (Welsh Branch) conference** (Wrexham, U.K.);
- An oral presentation entitled ‘Translanguaging: Boosting the acquisition of new knowledge using bilingualism’ at the **Society for the Neurobiology of Language (SNL) Annual Meeting** (San Diego, USA).

Finally, I gave three invited talks on the research included in this thesis:

- **‘Educational Neuroscience: What is really going on when we push ourselves?’** (Krakow, Poland). A presentation of the overall findings from my PhD thesis.
- **‘The electrophysiological basis of speech production and comprehension in bilingual adults’** (Vitoria, Spain). A talk on the findings from Chapter 6;
- **‘No longer the ‘B’ word. Finding the best way to educate bilingual children’** (Vitoria, Spain). A talk on the findings from Chapters 4 and 5.

Chapter 2

An overview of Translanguaging:

20 years of 'giving voice to those who do
not speak'.

This chapter has been peer-reviewed and published as:

Beres, A. M. (2015). *An overview of translanguaging: 20 years of 'giving voice to those who do not speak.'* *Translation and Translanguaging in Multilingual Contexts*, 1, 103-118.

doi: 10.1075/ttmc.1.1.05ber

Abstract

Over the last two decades, with the increasing bilingual population across the globe, it has become clear that we need to develop new approaches to language and education. Translanguaging is a term that was originally coined in Wales to describe a kind of bilingual education in which students receive information in one language, for example English, and produce an output of their learning in their second language, for example Welsh. Since then, scholars across the globe have developed this concept and it is now argued that it is the best way to educate bilingual children in the 21st century. The present article offers an overview of translanguaging from its origins in Wales to recent developments in the UK and the US. It first presents the traditional approaches to bilingualism in education, which viewed the first and second language as separate entities. Next, it explores how bilingual education can be transformed through the use of translanguaging and outlines current research in the UK. Finally, it proposes some avenues for future studies.

Keywords: translanguaging, bilingual education, bilingualism

1. General overview

For decades, schools have separated the languages used in learning and allocated separate teachers, lessons, or even days of the week to one language or the other. This approach largely stemmed from a belief that any mixing of two languages might confuse learners and therefore hinder their progress. As Jacobson and Faltis (1990) explain, the underlying reasoning of such thinking was that strict separation of the languages used was the only way to avoid ‘cross-contamination’. The effectiveness of such double-monolingual treatment of bilingualism has recently been questioned. Alternative methods, which take into account the needs of multilingual societies in the 21st century, have started to appear. It is now widely accepted that it is necessary to shift from approaching bilingualism as two separate, rigid and static languages, to viewing them as fluid, flexible and permeable. The concept of translanguaging has been developed within this new perspective over the last two decades.

Translanguaging is a relatively new notion that is still being developed. The term is the English equivalent of the Welsh word *trawsieithu*, which was coined by Cen Williams in his PhD thesis (1994a) to describe a teaching method adopted in bilingual secondary schools in Wales. This involved providing students with information in one language and asking them to produce a piece of written or oral work in the other language. An example might be preparing a poster in English and explaining it in Welsh. This pedagogical practice was intended to foster learning through meaning and understanding. It has since been developed by a number of educators, most notably Colin Baker (2003, 2006), who first translated the Welsh term as *translanguaging*, and Ofelia García (2009). García extended Williams’ original definition and placed it in the context of emergent bilingual children, mostly from Spanish-speaking homes living in the US. García argues for less rigid criteria of the proficiency of the two languages and focuses on how bilinguals naturally and flexibly use their entire linguistic repertoire. She places equal emphasis on the naturally occurring language practices of bilingual children and the adoption of bilingual pedagogies. She argues in favour of moving away from seeing the two languages as separate entities, recognizing that bilingual students

have one linguistic repertoire at their disposal. Hence they should be allowed to flexibly draw from it in order to choose the aspects that enable them to meet their complex communicative needs. Translanguaging can be used effectively to achieve proficiency in English and their native language as well as enhance their academic attainment.

2. Historical background

2.1 Turn of the 20th century

Bilingualism in Western education had been highly desirable for centuries. However, socio-economic changes and the development of printing press in the 15th century created the need to standardise the language used by communities to increase profits (García, 2014b). Those who did not ‘fit in’ were simply excluded from schooling. Homogenous language use was strongly favoured in education up until the early 20th century, when nations began to understand the benefits of educating all their citizens, regardless of their home language. Providing an education for all was the only way forward to achieve more industrialized and developed societies. However, as bilingualism was at the same time blamed for a range of behavioural and intellectual problems (Reynold, 1928 in Saunders, 1988; Weisgerber, 1933 in Saunders, 1988; Arsenian, 1937 in McLaughlin, 1978), the global aim was to achieve proficiency in the second language so that that bilingual children could eventually function monolingually. In Canada, Australia and New Zealand, the pursuit of this goal caused the complete suppression of indigenous languages. In the US there was a great need for all the new immigrants coming from different countries to become ‘monolingual’ English speakers. As a result, children from language-minority groups failed to perform well in schools, owing to their lack of proficiency in English (García, 2014b; García, 2014c).

2.2 Mid-20th century

Bilingual education that recognized children’s home-language practices alongside the second language began to gain recognition in the mid-20th century. However, these bilingual programmes were developed from a monolingual perspective that regarded bilingual individuals as having two separate languages. Moreover, many of those

programmes aimed at using students' home-language in a 'transitional' fashion, that is, only until they became proficient enough in the second language. From that moment onwards the second language became the sole language of instruction, hence their schooling was essentially monolingual (subtractive bilingualism). Additive bilingualism, which aimed at adding the second language and maintaining it over time alongside the first language, also saw the two languages as parallel rather than interactive. Around the same time, in a response to an increasing tension between French and English in Canada, the first early immersion programmes were established with the aim to make the Anglophone children bilingual. These programmes included the use of children's second language one hundred per cent of the time in the initial stages, followed by the equal use of their two languages. Similar programmes were later established in other countries such as the US and Australia. They included Japanese-English, Mandarin-English and French-English programmes, amongst others. A further development, known as two-way immersion programmes, included children from two different language groups and provided education in both languages. The goal was to achieve fluency in both languages. As prestigious as it was, this programme, like the previous ones, viewed bilingual education in terms of two independent languages. After decades of language separation, educators began to question the validity of such approach to bilingualism and whether it could fully represent the skills of bilingual individuals (Esquinca, 2011).

2.3 Turn of the 21st century and the 'B' word

2.3.1 The case of Wales in the UK

Like in the US, monolingual education in the UK was seen as desirable and natural for centuries. It is only in the last two decades that this view has been questioned. In Wales, for example, bilingual education is to be considered in the context of the historic separation of Welsh and English and the difference in prestige accorded to these languages. While English was regarded as the desirable form of communication, Welsh was perceived as 'irrelevant' and 'inferior' (Jones, 1982). The growth of bilingual education in Wales was, therefore, not only a response to the educational needs of Welsh students, but also a combination of cultural, social and political factors

concerning the Anglophone and English language dominance. This led to an increased cultural and nationalistic awareness and demand for social change (Baker, 1993). Welsh was given the same status as English in the eyes of the law in 1967 through the Welsh Language Act, after almost a century since the introduction of the 1870 Education Act, through which English-medium schooling had become compulsory throughout Wales (Malerich, 2008).

2.3.2 The case of the US

Towards the end of the 20th century, bilingual education came under attack once again, especially in the US, which turned to English-only schooling. Bilingual education was officially banned in California (1998), Arizona (2000) and Massachusetts (2002). The words ‘bilingual’ and ‘bilingualism’ were eliminated from all official documents and the emphasis was placed on the majority, dominant language. The US Office for Bilingual and Minority Language Affairs became the Office of English Language Acquisition. Bilingual education became either dual language or structured English immersion. Bilingual children became English Language Learners or Limited English Proficiency students and The Bilingual Education Act disappeared under the No Child Left Behind (NCLB) Legislation. Some started to refer to ‘bilingualism’ as the ‘B word’, suggesting that bilingualism had become something not to be named explicitly (García, 2014a).

The NCLB Act, which required satisfactory performance by students on standardised English tests in order for the schools to qualify for state funding, aimed to improve educational outcomes for children from all disadvantaged groups. However, it resulted in poorer achievements for bilingual children. Teachers and schools were made accountable for students’ performance, hence for school funding, through the increased use of standardised tests. As a result, the NCLB Act led schools to abandon bilingual instruction and replace it with English-only approaches (Crawford, 2007). ‘Teach to the test’ classrooms (Galvez, 2013) were created with the aim to prepare students for passing the standardised English tests. Menken (2006) pointed out that amongst a number of schools she visited after the introduction of NCLB Act, only one of them had

increased Spanish-language instruction in order to provide for the needs of their bilingual students. Unsurprisingly, this was also the school that had an increased 50% performance on standardised tests. This finding supports the interdependence theory put forward by Cummins (2000). The theory posits that emergent bilinguals can successfully apply the skills they learn in their home language to English language acquisition, as both languages are developmentally interdependent, whereas restricting their home language is linked to poorer school performance.

It comes as no surprise that when emergent bilinguals are tested in English, their success is limited, which in turn creates a problem for the schools that are under constant scrutiny to show continuous improvement. Luckily, it has also been shown that, when given voice and the right environment to flourish, emergent bilinguals can improve not only their English language skills but also their general academic achievements (Menken & Solorza, 2014). It is at this point that translanguaging comes into play.

3. Developments of translanguaging

3.1 Origins of translanguaging

As was said earlier in section 1, Cen Williams, a Welsh educator, coined the term *trawsieithu* to refer to a teaching method in Welsh secondary schools. The method involves the systematic alternation of two languages, so that children receive information in one language and produce a piece of work in the other language (Williams, 1994a; Williams, 2002). An example may be reading a history text in Welsh and discussing it in English. Through the systematic use of both languages in the same lesson, translanguaging enables students to internalise new knowledge, process it and then make sense of it in the other language. This process requires the use of a number of cognitive skills, both receptive and expressive, and results in a deeper understanding of the subject taught. Williams contends that this method may not be as effective with emergent bilinguals as it is with pupils who are fluent in both languages (Williams, 2002).

It is important to remember the broader social and political context at the time, when Welsh and English were regarded as completely separate communicative strategies, with a huge difference in prestige and status. Therefore, the introduction of translanguaging was seen as a major step away from separating the two languages and the first step towards using them concurrently in the same lesson. Williams pointed out that children use both their languages in order to maximise their understanding and they translanguage naturally on a daily basis (Williams, 2002).

3.2 Further research in Wales

Colin Baker (2003, 2006) has further examined the use and advantages of translanguaging. He argues that it has the potential to enable a deeper understanding of the subject taught, because in order to discuss in one language what has been learned in another, students must have understood the meaning of a given topic at a deep, detailed level. Moreover, it encourages school-home interaction, with parents being able to support their children's work at home in their native language. Finally, not only does translanguaging improve children's knowledge of the second language, but it also develops their overall learning. Two languages are used in a structured way in order to organise and facilitate mental processes in learning. Baker argues that in translanguaging, it is much more difficult for students to perform well without fully understanding the subject. Unlike in a monolingual classroom, where it is fairly easy for children to pick up on some key concepts and essentially copy-and-paste the information, translanguaging requires a deeper understanding if the input information is to be discussed in another language. Translanguaging, therefore, involves learning through meaning.

3.3 A global take on translanguaging

What started in Wales as a local pedagogy has now been recognised by scholars around the world. Among them, Ofelia García has been credited with popularising translanguaging globally and developing it further. Her approach to translanguaging is holistic in that it posits that "the language practices being learned by emergent bilinguals are in functional interrelationship with other language practices and form an integrated system" (Velasco & García, 2014, p.7). Also, translanguaging is considered

to be as effective with fluent bilinguals as with emergent bilinguals such as children from Spanish speaking homes living in the US. Moreover, García argues that translanguaging is a common, everyday practice in the multilingual societies of the 21st century. Not only does it increase students' competence in their additional language, but it also makes them more skilled academically. García takes William's and Baker's views further and emphasises that children can translanguage even when they have minimal knowledge of both languages.

García contends that since bilingualism does not entail the use of two separate linguistic codes, translanguaging is not just about switching languages and modes of learning (e.g., going from reading to writing). Instead, translanguaging is based on the idea that individuals can draw on their entire linguistic repertoire in order to meet their communicative needs. García and Li Wei (2014) argue that translanguaging is a process whereby individuals use various meaning-making signs in order to adapt and actively participate in different societal and linguistic situations critically and with cognitive engagement and creativity (66-68). Translanguaging enables bilinguals to develop new understandings of interaction between people and create a free and equal environment in which everyone is given a voice. It allows students to shine and show their true knowledge and potential. For García and Li Wei (2014) individuals' knowledge and use of languages are closely linked and permeable with their knowledge of social and human interactions. To sum up, for García and Li Wei translanguaging is more than a learning strategy. It is "the discursive norm of all bilinguals, as well as a pedagogical theory of learning and teaching" (García & Li Wei, 2014, p.126), especially for language-minoritized populations. Indeed, translanguaging provides the conceptual framework for theorizing on bilingual education as a democratic endeavor for social justice (García, 2013c).

3.4 Further international research on translanguaging

Other scholars have provided their own definitions of and insights into translanguaging. What was labelled as *trawsieithu* by Williams (1994a) and *translanguaging* by Baker (2003) and García (2009) is termed *codemeshing* by Canagarajah (2011),

metrolingualism by Otsuji and Pennycook (2010) and *translanguaging space* by Li Wei (2011). Although they all uphold the flexibility of language use rather than traditional language separation, each of these definitions views the use of translanguaging slightly differently and focuses on slightly different aspects of sociolinguistic bilingual practices.

Since Baker's and García's initial work on translanguaging, a number of studies have discussed its use in academic and social contexts. Some of these studies have concentrated on using translanguaging in writing. Canagarajah (2011) has shown the use of different strategies in writing. His term *codemeshing* refers not only to mixing codes to enhance learning, but also to symbols other than languages. Creese and Blackledge (2011) have investigated multilingual practices in complementary schools in the UK, which concentrate on native-language learning and culture classes, rather than general education. They found that students and teachers can manifest flexible bilingualism (fluid and permeable) and language separation (rigid and distinct language barriers) at the same time, as these two seemingly opposite strategies are not so clear-cut for pupils and staff alike. They strongly argue for the benefits of flexible use of languages to better understand students' identities. Esquinca (2011) analysed the writing of two Spanish-English college students and discovered that they used a number of resources to help them create mathematical meaning. They talked about the text in their first language and wrote about it later in the second language. He affirms the importance of translanguaging in social context, which enables students to create the meanings of the written text and make it possible for them to move across the continua of biliteracy. He also states that translanguaging can occur as soon as students have enough knowledge of the second language to be able to use it for learning purposes. Velasco and García (2014) investigated the use of translanguaging as a strategy to boost academic writing and found that it helps children self-regulate their linguistic repertoire and perform better than if they were to use only one language. They were developing their creativity and language skills, and therefore their overall attainment. The importance of these cultural aspects is echoed by Blackledge and Creese (2010), who argue that translanguaging helps pupils to negotiate different language and cultural identities in their home and in the community.

A number of studies have looked at translanguaging from perspectives that address academic, social, cultural and identity issues. Hornberger and Link (2012) expand on the original idea of translanguaging and focus on the practice of transnational literacies that are based on cross-border identities, skills and social relationships. They argue for increasing awareness of translanguaging and transnational practices in multicultural classrooms in order to increase our understanding of students' resources and how these can be used to enrich their educational attainments. They believe that translanguaging is as much about learning the language as it is about having a positive school experience and academic attainment.

García and Sylvan (2011) have developed the idea of translanguaging within a 'dynamic plurilingual pedagogy' which maintains that it is necessary to focus on the individual in multilingual and multicultural schools. Therefore, successful and meaningful bilingual education involves the purposeful engagement of teachers and pupils from a variety of different backgrounds, with their individual cultural and linguistic repertoires. They argue for improving English language skills and general knowledge through the use of translanguaging by emergent bilingual children. They also contend that successful translanguaging is a process based on continuous adaptations of the students' entire linguistic repertoire in order to create meaning.

Li Wei (2011) argues for the creative and critical use of the bilinguals' entire social and cultural space. His stance on translanguaging stems from the concept of languaging, namely a process whereby individuals 'do' languages, rather than 'have' them (García, 2011; García, 2014b). Therefore, translanguaging for him also includes a space for people's history, values, identities and abilities. Expanding on the concept of translanguaging space, Wei (2014) investigated Chinese complementary schools in the UK. These schools are a great source of knowledge of different linguistic systems and socio-cultural aspects necessary for the well-being of an individual. They foster translanguaging, funds of knowledge and symbolic competence, which involves increasing language skills and understanding the context in which such skills are

employed. Teachers and students bring different sets of funds of knowledge into the school. These include language, life and cultural experiences. Teachers usually demonstrate their personal relationship with China, whilst students lack this intimate aspect of learning since they are mainly British-born. These differences provide important learning resources, but may also create conflict. It is therefore crucial to learn how to use these resources properly so to create a positive environment, which can benefit teachers and students alike. Through this symbiotic relationship, they can reflect on who they are and how they can profit from the knowledge and experiences of others.

Kano (2013), in her PhD thesis, examined the process between the input in one language and the output in another, thus extending the initial definition of translanguaging to involve *thinking* as the in-between step necessary to digest the information. She also stresses the difference between code-switching and translanguaging, in that the first one involves merely shifts in codes (languages) whereas the latter involves changes in both codes (languages) and modes (reading and writing, listening and speaking, or a mix of those). Translanguaging is a complex, dynamic process involving a mixture of different practices and may include what others denote as translation and code-switching. The process that takes place alongside code-switching and translation is also viewed as a key aspect of translanguaging by García, as one that enables bilinguals to make sense of the words since “fixed identities and meanings are questioned, and new signification is made” (García, 2013a, p.162). Through translanguaging and flexible use of meaning-making signs, bilingual individuals can adapt and function flexibly in different social and communicative situations (García & Li Wei, 2014).

4. General discussion of translanguaging

Translanguaging challenges the idea still popular in many parts of the world today according to which non-native students have somehow deficient skills due to their lack of proficiency in their additional language. It is this view that was behind the idea of some educational methods, such as immersion, where students were required to use only the second language. Code-switching and other aspects of mixing languages,

which go against the principle of language separation, are discouraged and often officially forbidden by school policies. This can create feelings of exclusion or even failure, because students lack the skills that enable them to fully express themselves in the target language (Cenoz & Gorter, 2011). It can, however, be overcome by the use of flexible languaging, where students can use aspects of their entire linguistic repertoire in order to address their communicative needs.

Translanguaging in its pure form goes back to Moll and Diaz (1985), who showed that, by discussing in Spanish what they had read in English, Spanish emergent bilingual children increased their reading proficiency in English, which became comparable to their first language. Knowing how students learn and function is the key to successful learning and teaching. Translanguaging allows students to use their personal skills and repertoire as they naturally do in their bilingual world.

Translanguaging does not assume that individuals have two separate language codes, but rather that they have one linguistic repertoire from which they choose the information they need in a particular context. Although it includes code-switching, it is much more than that. Rather than focusing solely on the second language and therefore essentially ignoring bilingualism, translanguaging enables teachers and pupils alike to see bilingualism as a resource that can facilitate the acquisition of language skills and general knowledge (García, 2012).

Translanguaging enables permeability between languages (Creese & Blackledge 2010; García, 2011). Bilinguals need to be able to draw from their entire linguistic system those aspects, which enable them to make the connection with one another, explain their thoughts and feelings and learn new skills. It is only through such flexible bilingualism that links between language, culture, community and context can be established. This permeability is maintained by Park (2013), who argues that it enables students to fully participate during the lesson as they do not feel constrained by the disproportionate gap between the two languages.

Translanguaging is often confused with code-switching. The latter is described as a strategy adopted by bilingual speakers, which entails the use of two languages intrasententially and intersententially (Cook, 2001). Whilst translanguaging includes code-switching, it goes beyond that. Translanguaging is about drawing from a complex linguistic system that does not clearly fit into one language or another as described by nation-states and grammar books. It is about using this linguistic repertoire in a flexible way in order to gain new knowledge, develop new skills and enhance language practice. What makes translanguaging important in teaching emergent bilinguals is that by allowing students to flexibly choose those aspects, which work for them at the time, it enables them to participate in a situation they otherwise would be excluded from. Therefore, it boosts their confidence as well as their skills. It also builds on their strengths rather than weaknesses, i.e. skills which they are just acquiring, and minimises the feeling of alienation. Translanguaging can give “voice to those who do not speak” (García 2014a, p.115). It also involves simultaneous shifts in modes (Kano, 2013), that is to say shifting between comprehension and production, e.g. from reading or listening to writing or talking.

It is important to pause and consider what ‘proficient’, ‘fluent’ or ‘balanced’ bilingualism means in today’s world. García (2013b) has questioned what being a ‘native’ speaker really entails. For decades, being ‘native’ has been seen as the ideal concept. It equates to an individual being ‘proficient’ in both languages. However, this view is now being challenged, especially with the intense globalization of the 21st century. It is now widely accepted that the concept of ‘perfect’ bilingualism, in which both languages are balanced and used equally proficiently, rarely exists, if ever (Grosjean, 2010; Valdes, 2005). Bilinguals are not “two monolinguals in one” (Grosjean, 1989) and the very act of simply acquiring a new language changes an individual’s cognitive system (Cook, 2007). Therefore, even a highly proficient speaker of two or more languages will use his or her skills differently from a monolingual speaker, owing to their unique set of competences, which arise from the ability to flexibly function in a bilingual environment. Such approach enables us to consider the process, rather than the end result, of bilingualism and bilingual education. García

(2013b) also argues that bilinguals are not purely first and second language speakers. Simply adding a second language is not a linear process. The acquisition of a new language is dynamic and in constant interaction with the first one, thus creating a new linguistic repertoire. By creating this linguistic system, translanguaging permits the full participation, in the classroom as in the wider society, of those who otherwise would be restrained by their emerging second language. It is important to note that apart from the broad linguistic skills that bilinguals possess, bilingualism has an impact on people's general well-being and the benefits of bilingualism are "above all, social and psychological rather than linguistic" (Edwards, 2003, p.41).

García (2006) asserts that the overarching aim of translanguaging is for pupils to develop a repertoire of codes and strategies that enable them to strategically use them, rather than gaining mastery of the second language. Apart from developing language proficiency and expanding on students' general academic knowledge and abilities, translanguaging has the potential to transform the public education system in the US, which is still predominantly in English, by recognizing the language practices used by speakers of languages other than English in the US (García et al., 2012). Moreover, she states that it is only by adopting a translanguaging pedagogy that language minority students across the world will be able to successfully perform in global tests such as PISA (Program for International Student Assessment), which is administered worldwide every 3 years to teenagers across the world (García, 2014b). Through translanguaging, individuals can self-regulate their use of language in relation to the situation they are in by drawing meaning-making aspects from their entire linguistic repertoire which enable them to act, to be, and to know. They are in control of their own learning not only in the context of education, but also of their everyday lives as they function in a globalized world of the 21st century (García & Li Wei, 2014).

5. Current research on translanguaging

5.1 Translanguaging in the community

Creese and her team at the University of Birmingham, UK are currently investigating translation and translanguaging in four major British cities. The cultural and linguistic

landscape of the UK is very diverse and the aim of this work is to establish how people from different linguistic and cultural backgrounds communicate successfully. The goal is to establish what happens to languages and how they interact in this varied context. The work will be conducted in various contexts in society such as business, sports and legal systems in order to establish the patterns of how individuals operate within each of those sites in a highly multilingual and multicultural environment. The overarching aim of this project is to have productive discussions with different institutions and contribute to policies on multilingualism as well as to understand the role that multilingualism can play in improving business, sports, diplomacy, education, health and general well being. Funded by the Arts and Humanities Research Council, this project will be undertaken from 2014 to 2018 and is intended to have a positive impact on the wider multicultural community of 21st century Britain (see the project's dedicated website for more details www.birmingham.ac.uk/generic/tlang/about/index.aspx).

5.2 Neural underpinnings of translanguaging

A recent development is the investigation of the neural bases of translanguaging. This PhD research project is being undertaken at the School of Psychology, Bangor University, Wales (Beres, 2014). The departure point of this study is the initial definition of translanguaging, as proposed by Cen Williams (1994a), that is translanguaging entails receiving information in one language and producing it in another. The participants are 'proficient' Welsh-English bilinguals, who use what Kano (2013) terms 'independent translanguaging', whereby both languages are used similarly, which in turn enables individuals to self-regulate their translanguaging mechanisms. Neuroscientific methods such as event-related brain potentials (ERPs) are being used to determine the effects of acquiring new knowledge through the medium of just one as opposed to both languages. A group of bilinguals were tested on a novel-object learning task. The learning context was manipulated. In a monolingual block, the information presented at input was in the same language as the one that the participants were asked to use when producing an output of their learning. In a translanguaging context, participants produced the response of their learning in a language different from the one of instruction. The N400 component of the ERPs, known to index semantic integration

effort, was a measure of choice when testing participants' knowledge after their learning was completed. Participants' knowledge was tested using a classic picture-picture priming paradigm, involving related and unrelated picture pairs according to the learned definition. As expected, a semantic priming effect was found, indexed by amplitude reduction of the N400 wave, when novel objects were followed by their learned related as compared to the unrelated picture.

Moreover, it was found that novel objects learned through translanguaging induced more priming, hence produced a smaller N400 wave, compared with the same objects learned in a monolingual context. This suggests that less effort was required to retrieve and process the information that was acquired through translanguaging. Furthermore, this effect was found to be long lasting and was still measurable a few weeks later after the initial testing, without any revision of the learned information. These results suggest that translanguaging successfully heightens the level of the conceptual system. These experiments provide neuroscientific, quantitative evidence of the benefits of using language alternation in new knowledge acquisition. This research addresses translanguaging from a different viewpoint and adds to the growing body of evidence that this learning strategy enables students to engage in deeper thinking and therefore more meaningful learning.

6. The future of translanguaging

There seems to be little doubt that translanguaging is beneficial in bilingual education. However, more work needs to be done if we wish to fully understand the mechanisms of translanguaging and establish its pedagogical potential. What is needed at this stage is an investigation of the individual components of translanguaging in order to understand what makes this practice a successful learning and teaching strategy. To this end, it is important to examine the role that code-switching and going from comprehension-to-production play in translanguaging. It is also important to establish the influence of age and language proficiency on the effectiveness of translanguaging as pedagogy. Other avenues of future research may include how translanguaging relates to individuals who speak more than two languages, how it can be used in an online

learning situation and how it may change assessment procedures. An additional strand of research could investigate translanguaging with other groups of bilingual learners such as dyslexic students or bi-modal bilinguals such as the Deaf.

Chapter 3

Time is of the essence.

Electroencephalography (EEG) and event-related brain potentials (ERPs).

Electroencephalography has come a long way since its discovery 140 years ago by an English physician Richard Caton. He was the first person to establish that there are electrical currents in the brain. In 1875, he obtained the first EEG from open brains of monkeys and rabbits. Almost 50 years later, in 1924, Hans Berger, a German neurologist, made the first EEG recording on the human scalp, by using simple radio equipment in order to amplify the electrical activity of the brain, and obtained a written output on paper. He claimed that brain activity that is observed through the use of EEG can change in a consistent, reliable and recognisable fashion when the state of the patient changes, such as going from relaxation to alertness, sleep, lack of oxygen (Bronzino, 1995). This breakthrough gave rise for the research of the years to come and the varied applications of EEG use today.

EEG plays a crucial role in many aspects of today's research. It is used in medicine, where monitoring brain activity (or the lack of thereof) is useful in determining brain death in patients, areas of damage following a stroke or head trauma, epileptic activity, sleep disorders, and many others. In other research, it is useful in investigating various cognitive functions, such as memory or attention; it is also used in language and clinical research, for example one that looks at individuals with aphasia.

This chapter starts with a short description of EEG. It then focuses on the ERPs, and their use in experimental settings. It describes the typical set-up of an ERP experiment. Following that, more details about the use of ERPs in the present thesis are given. A description of a number of ERP components typically involved in language research is presented. Finally, the advantages and disadvantages of using ERPs in research are discussed.

All of the experiments presented in this thesis employed the use of ERPs as a method of choice. Where possible and relevant to the research question, behavioural data, such as reaction times (RTs) and accuracy, was also obtained.

1. Short introduction

The average human brain has about 86 billion neurons (Herculano-Houzel, 2009), and the communication between them is the key brain activity. They are excitable cells with intrinsic electrical properties, and their activity results in magnetic as well as electrical fields, which can then be recorded with the use of recording electrodes.

The EEG is the recording of the summed electrical activity of population of neurons, through the use of electrodes placed on the scalp. The neuronal activity creates time-varying electrical currents, consisting of trans-membrane currents. There are two main types of neuronal activity, namely action potential and postsynaptic potential. Action potential is a very rapid depolarisation of neuronal membranes resulting in action potentials mediated by sodium and potassium. They are discrete electrical spikes, which travel from the beginning of the axon at the cell body to the axon terminals. It is at the terminals where the neurotransmitters are released. Postsynaptic potential is mediated by a number of neurotransmitter systems and, as a result of synaptic activation, generally entails slower changes in membrane potential (Lopes da Silva, 2010). They are voltages produced when the neurotransmitters bind to the receptors on the membrane of the postsynaptic cell, making ion channels open or close.

Reliably, EEG can only record postsynaptic potentials. It is because action potentials are very rapid and brief, in addition to having to travel down the axon at a fixed rate, so the electrodes placed on the scalp simply cannot detect them. Postsynaptic potentials, on the other hand, occur almost instantaneously, and they last sometimes hundreds of milliseconds longer than action potentials.

2. Event-related brain potentials (ERPs)

For decades, EEG recording was of great use in research and clinical settings. However, it is very difficult, if not impossible, to use the raw, continuous recording to examine the specific neural activity as a function of certain cognitive processes.

Event-related brain potentials are small parts of the continuous EEG recording, which are evoked in response to stimuli, such as viewing of pictures or words on the computer screen. In cognitive neuroscience experiments, it is not very informative to just use a continuous EEG recording. If we are interested in, for example, how the brain deals with language comprehension or production, we need the recording to reflect the modulation of brain activity by that particular task, in a precise moment in time. Therefore, it is necessary to look at the ERPs, rather than a continuous EEG recording. ERPs are obtained by time-locking the stimuli, through which we know at exactly which point the stimuli were presented and therefore analyse the brain response to a particular sound, word, picture, and so on.

ERPs are used in a range of psychological experiments, which aim to investigate various aspects of cognitive processes, such as language comprehension and production, memory, attention, amongst many others. ERPs cannot be typically seen within the raw EEG recording, because of their very small amplitude (Teplan, 2002). Therefore, they need to be singled out from the continuous recording by creating an average of recording periods, known as epochs, which are time-locked to repeated presentations of stimuli. The spontaneous EEG fluctuations, unrelated to stimulus presentation, are averaged out, resulting in the ERP wave, which reflects only the activity persistently related to the time-locked presentation of stimuli. Therefore, it can be said that the ERPs mirror the neuronal activity evoked by the repeated presentation of a stimulus.

2.1 How does it work?

Below, is an example of an experimental setting used in ERP studies.

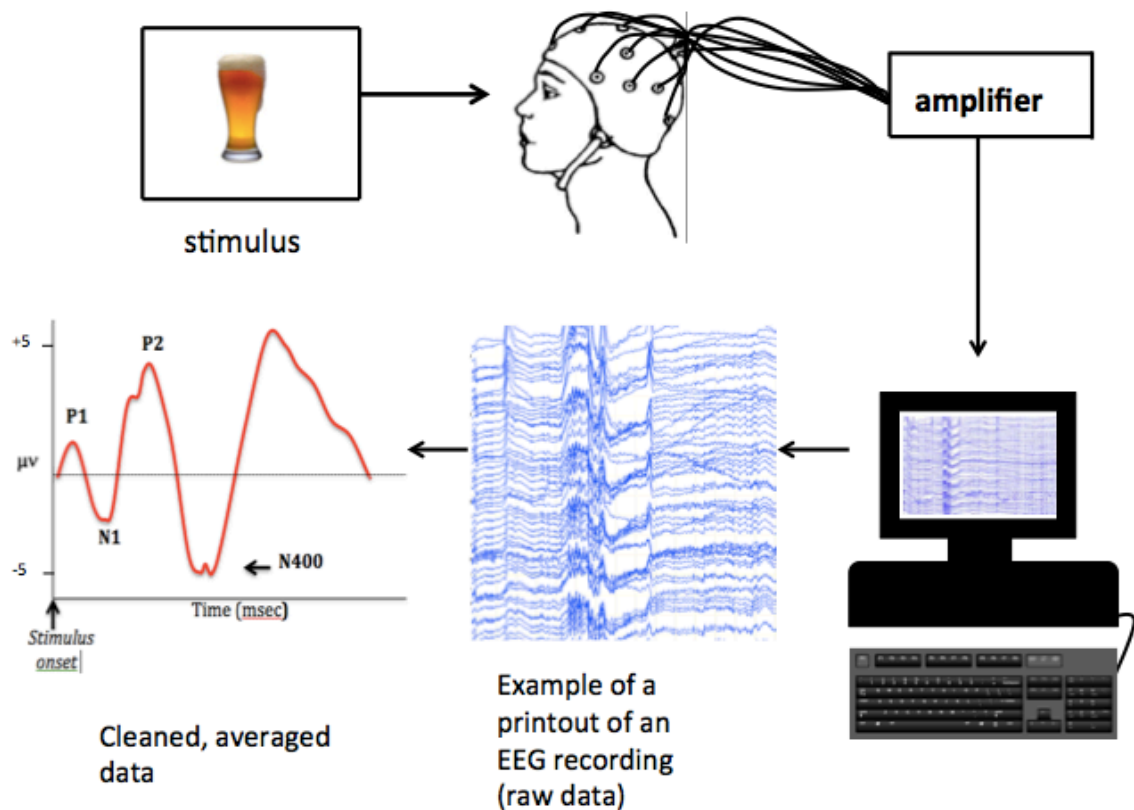

Figure 1. In an experimental setting, a number of electrodes, usually 32, 64, or 128, are placed on a participant's head, which enables the electrical brain activity to be measured on the surface (scalp).

The participant is presented, in this case, with a visual stimulus (a picture) on a computer screen. It then evokes a response by the brain, which is continuously recorded on the computer. This recording is then averaged, and individual ERPs, locked to that stimulus which was presented, get extracted.

EEG signal is obtained by recording the electrical activity, which is produced by the brain with the use of electrodes set at different sites on scalp (see Figure 2, below, for the array and placement of electrodes used in the present thesis). The signal at any one

electrode is obtained from the difference in electrical potential between the electrode and a ground electrode relative to the difference between a reference electrode and the ground. In the present thesis, the reference electrode was set to Cz and then re-referenced to the common average. The recording was always performed from 64 sites, evenly distributed over the scalp according to the 10/20 convention. All studies recorded activity from an extra 2 electrodes used to monitor vertical and horizontal eye movements (placed on the right side – one below, and one in the corner of the right eye). Eye-movements and blinks can contaminate the EEG recording and are “the result of the intrinsic voltage gradient of the eye” (Luck, 2005, p.162). The EEG recording can be visually inspected for eye-blinks as these are distributed across the scalp but have the most power in the frontal region, and inverse potentials are often found over the parietal and occipital sites.

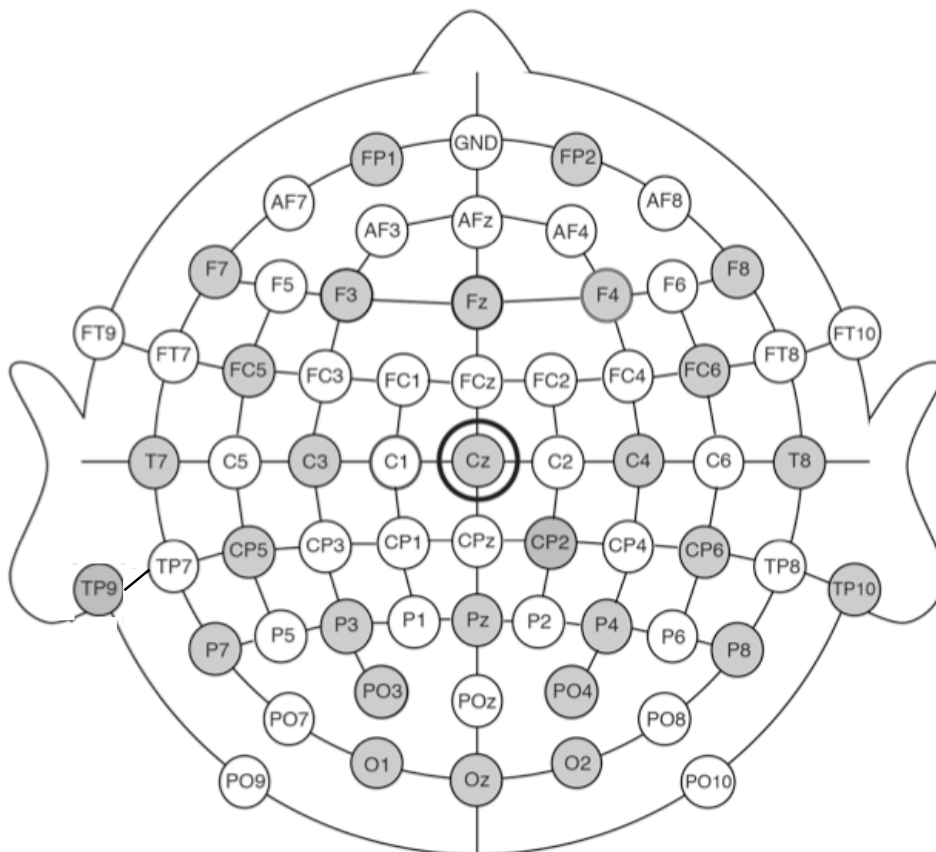

Figure 2. Electrode array used in this thesis. The circle around Cz indicates that this electrode was used as the online reference electrode.

2.2 Use of EEG in the present thesis

The electrodes are not in direct contact with the scalp. They are mounted in a round, plastic part and embedded within the elastic cap that participants put on their heads. Therefore, it is essential to reduce electrical impedance. This is done by using conductive gel in the set up of the electrodes, which essentially creates a ‘bridge’ between the electrodes and the scalp. The resistance is maintained below 5 kOhm for the scalp electrodes, and 10 kOhm for the external ones. The electrical signal that is produced at the surface of the scalp is very weak and therefore needs to be amplified close to the electrodes because it can decline very quickly in electrical wires, which have their own impedance. The sampling rate used was 1kHz.

Upon obtaining the recording, the continuous EEG data was subjected to the off-line filtering through a zero phase shift digital filter at 30 Hz (48 dB slope) in order to reduce the contamination from outside electrical noise. Following that, the continuous data was corrected for artefacts created by excessive eye movements and eye blinks (using Gratton et al., 1983, method in Chapters 4 and 5, and a semi-automated rejection strategy provided in the ERPLAB, Lopez-Calderon & Luck, 2014, in chapter 6), and periods in which activity exceeded +75 mV/-75 mV were rejected. Following that, the recording was re-referenced to a common average reference from a fixed site (Cz). This is often performed in EEG research, because the outward positive and negative currents summed across the sphere (scalp) will balance out to zero (Ohm’s law). Lastly, the continuous data was divided into epochs lasting from 100ms before the onset of the stimulus to either 1000ms after (Chapter 4 and 5) or 700ms after (Chapter 6). They were time-locked to stimulus onset, and averaged across trials of the same type (conditions). The created individual averages were then averaged across participants to create grand averages, in order to cancel out individual differences.

Following those processing steps, mean amplitudes were used to quantify the observed effects. The data was subjected to factorial Analyses of Variance (ANOVAs).

2.3 ERP components

The point of extracting and analysing ERP components from the continuous data in research is to average the activity over a number of trials in each condition. Only the activity that is recurrent and time-locked will not be cancelled out and therefore has some meaning. The output, which is obtained resembles a wave, with a number of positive and negative peaks. Those peaks are known as ‘components’ and labelled according to their polarity with P standing for positive, and N for negative, and their approximate latency in milliseconds (for example, P100 is the positive peak appearing around 100ms after the onset of the stimulus). In this thesis, the negative is always plotted down, and the positive – up. There are many known ERP components involved in language research. Figure 3, below, presents some of the most studied ERP components.

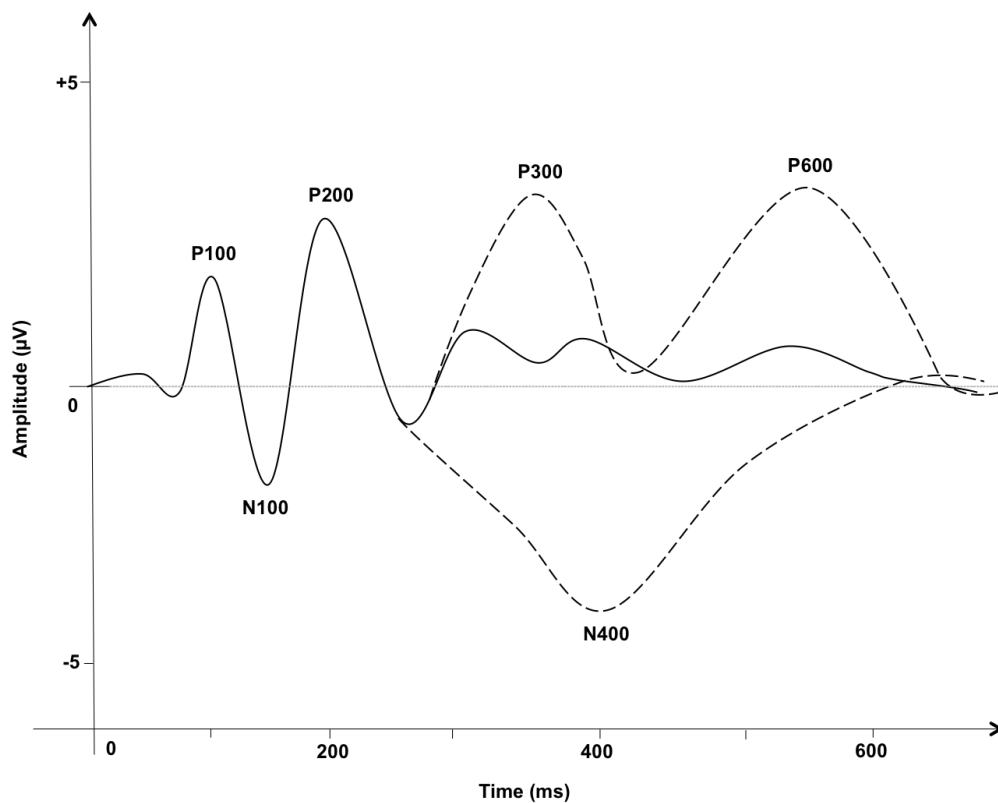

Figure 3. Some of the most commonly studied ERP components in language research. Solid line represents the basic perceptual components in an experiment involving any visual stimuli, such as words or pictures. Two dashed lines represent additional components, which are elicited in certain experimental designs.

Some components (P100, N100, P200) are generally linked with basic, low-level perception and are thought to be automatic in nature. This means, that as long as a perceptual stimulus such as a word or a picture is presented, they should be elicited. Other components, which come later, are elicited in certain experimental conditions. This distinction of early-automatic and late-more conscious components is made just to illustrate the general idea of ERP components. This generalisation may not be valid in all cases, and the functional significance of each peak is often task-dependent and the experimental paradigm should always be considered.

2.4 Components most commonly implicated in language research

2.4.1 What do you *mean*? The N400 component

N400 is one of the best and most studied language components. It was first reported by Kutas & Hillyard (1980). Over the last 30 years, it has been used as a dependent variable in more than 1000 studies, with topics ranging from language comprehension, through semantic memory, processing of faces and gestures, to clinical studies such as those that looked at developmental disorders. It was discovered by accident, in a modified experiment aimed at eliciting a P3b response for language materials (Kutas & Hillyard, 1980). Participants were presented word-by-word with sentences, which had either a congruent ending (75% of stimuli), such as *'I shaved off my moustache and beard'*, and 25% of sentences which either had a strange ending (*'He planted string beans in his car'*) or completely incorrect endings (*'I take my coffee with cream and dog'*). As a result, a large negativity was elicited – largest for semantically anomalous sentences, but present also for those, which had a strange, although probable, ending. It peaked around 400ms after the onset of target word, and was labelled the N400 (Kutas & Federmeier, 2011).

The N400 is found in a number of different experimental paradigms. Firstly, it has been well documented in lexical priming paradigms. The N400 effect (created by the

different waves of the congruent – incongruent stimuli) is found when the target word is unrelated (for example, semantically or categorically) to the preceding word (prime). The unrelated pairs induce larger N400 amplitudes as opposed to the related ones. Secondly, it has been found in auditory word presentation (for example, Bentin et al., 1993). In those experiments, the N400 appears slightly earlier than in the case of visual word presentation (but only in natural speech; when presented at a fixed rate, there is no shift in timing) and lasts longer. It also has a more frontal topography, less concentrated on the right (Holcomb & Anderson, 1993).

It is important to note that the N400 is not elicited to just any unexpected language manipulations. For example, it is not found in studies using capital letters for the target word when the rest of the sentence is in lower-cases (e.g. *'I shaved off my moustache and **BEARD**'*) or those using simple grammatical violations, such as having a singular form of the noun when it should have been plural (e.g. *'All turtles have four **leg**'*). The N400 effect is not elicited as a response to just any violation, linguistic or not. It is very closely linked with the processing of meaning. It is especially powerful in language studies, however its application goes beyond that (Kutas & Federmeier, 2011). The component's sensitivity to meaningful stimuli enabled a range of semantic investigations to take place, that is those, which focus on how the semantic memory is stored and retrieved in the brain (commonly referred to as semantic memory).

Kutas and Federmeier (2011) point out that out of a range of different studies, two main streams of findings are prevalent. Firstly, there is a disparity between the behavioural outcomes (reaction times) and the ERPs. That is, only rarely do those two behave in a similar pattern. This is perhaps not surprising given that with behavioural measures such as RTs, a number of cognitive processes take place and get consolidated by the time the individual makes a response; whereas with the ERPs, the components of interest reflect only a specific fraction of the whole process. Secondly, the results obtained through the ERP analysis often fail to fully support an existing theory, thus supporting different elements of various theoretical approaches.

The N400 has been reported across different modalities, such as speech production (for example, Strijkers & Costa, 2011) sign language (for example, Kutas et al., 1987), and pseudowords (for example, Leinonen et al., 2009; Friedrich et al., 2006), pictures (for example, Nigam et al., 1992; West & Holcomb, 2002; McPherson & Holcomb, 1999), faces (for example, Debruille et al., 1996; Barrett & Rugg, 1989). However, it is important to mention that topographies of the N400 distributions can vary in each of those contexts (Kutas & Federmeier, 2011). As the N400 effect has been found in studies, which used different types of stimuli, such as words, pictures, and sounds, amongst others, Kutas and Federmeier (2011) argue that the N400 effect should be seen as “modality-dependent but not modality-specific” (p. 9). That is, different types of stimuli can elicit the N400s, but those, although they have many broad similarities (such as waveshape and timecourse), depend on the type of stimuli used and vary in terms of the specifics (especially when it comes to topography). And so, for example, written words elicit an N400 which is strongest in centro-parietal region, whereas pictures are concentrated in the fronto-central regions. Furthermore, when comparing within-participant differences, van Petten & Riefelder (1995) found that when presented with visual/auditory words and meaningful environmental sounds, either meaningfully related or not to the upcoming words, the N400 was more right hemisphere dominant in the case of words, but left hemisphere dominant in the case of environmental sounds. Even though the N400 has been found in studies using sounds, the N400 effect does not reliably appear in classic music experiments. Instead, those consistently elicit a P3b response (Besson & Macar, 1987).

Looking at all of studies which reported the N400, it is difficult not to conclude that our unique ability to see the *meaning* in the world around us, to which the N400 is susceptible, is underpinned by a number of cognitive processes, such as attention, memory, language, perception, amongst many others. The N400 therefore seems to be a very reliable and solid component with which we can study processes directly linked to semantic integration.

2.4.2 The preceding context matters – the P600 component

P600 is a positive wave of activity occurring around 500-800 ms after the onset of a target word. It is an index of processing syntactically incorrect or non-preferred sentences (Osterhout & Holcomb, 1992; Hagoort et al., 1993). Osterhout and colleagues (1994) argue that the P600 component varies with the degree to which a syntactic continuation of a sentence is expected. That is, grammatically incorrect continuations result in a larger P600 than those, which are grammatical but non-preferred. It has also been found to be sensitive to continuations which are more difficult to process even though they are grammatically correct and preferred, compared to a control condition (Kaan et al., 2000). Additionally, recently the P600 has been linked with monitoring and re-evaluation processes (Kolk et al., 2003; Kolk & Chwilla, 2007; van de Meerendonk et al., 2010). Therefore, the P600 can reflect the ‘double-checking’ of the information, which is expected in the processing of syntactically abnormal sentences. In addition to syntax, the P600 has been found to be elicited in some situations outside of the language context, such as violations in music (Besson & Macar, 1987; Patel et al., 1998), mathematics (Lelekov et al., 2000), and sequencing (Núñez-Pena & Honrubia-Serrano, 2004). This implies that the P600 component is sensitive to a violation of any expected structure, whether linguistic or not.

Some investigators took advantage of the fact that some syntactic violations can impact semantics, and investigated the processing of less clear-cut psycholinguistic aspects, such as the gender agreement between a pronoun (her) and its antecedent (the boy). In this example, such processing could be argued to be syntactic (constrained by an individual’s grammar) or semantic (part of the word’s meaning and how those words are used in speech). The results of such experiments clearly show that similar violations only modulate the P600 (and possibly LAN) rather than the N400, suggesting that they were perceived as syntactic rather than lexico-semantic (Osterhout & Mobley, 1995).

2.4.3 Left anterior negativity (LAN)

Another component, known to also index syntactic processing, is the Left-Anterior Negativity (LAN). It is a negative wave of activity, peaking around 300-500 ms window on the frontal part of the left side of the scalp. However, this location has not been found to be consistent across studies (Hagoort et al., 2003). It is elicited by grammatical violations (e.g., Kutas & Hillyards, 1983; Friederici et al., 1993) and garden path sentences (Kaan & Swaab, 2003), albeit less frequently. A distinction can be made between an early LAN (ELAN), elicited around 100-200ms after stimulus onset, and LAN appearing in the 300-500ms window. The ELAN has been implicated with automatic processing of phrase structure information and is elicited when phrase structure or word category is violated, such as when a passive participle (not a noun) follows a determiner (e.g., Neville et al., 1991; Friederici et al., 1993). The later component, LAN, has been initially implied by Friederici and colleagues (2002) to be elicited by problems with morpho-syntactic agreement process, but later this interpretation has been questioned. Hagoort and colleagues (2003) elicited it for phrase structure violations, and Deutsch and Bentin (2001) found it to be an early index for agreement violations. There is a debate about the language specificity of the LAN, with some researchers claiming that it reflects processes specific to syntax, whilst others that it is a more general index of working memory load (Kluender and Kutas, 1993a; Kluender and Kutas, 1993b; Coulson et al., 1998).

In the literature, it is common to find (E)LAN component(s) followed by the P600, with the P600 thought to reflect post-hoc integration of various streams of information and the repair of anomalies involving sentence structure, and possible semantic inconsistencies.

2.4.4 Mismatch negativity (MMN)

This component reflects auditory deviance, and therefore is used in speech perception research. It is a negative deflection, peaking around 160-220ms after stimulus onset

(Luck, 2005). It is elicited in an auditory oddball paradigm, in which one 'standard' sound is presented frequently, whilst another, 'deviant' (which differs in pitch, duration, and other acoustic/phonetic properties from the standard) is presented randomly and infrequently. MMN is observed if the difference between the standards and deviants has been registered. MMN has been suggested to act at the pre-attentional level, since it can be elicited in coma individuals (for example, Näätänen, 2003). It can also be elicited when listening to music, watching a movie, reading a book, or sleeping, and individuals do not have to engage in a specific activity. MMN is believed to be a result of an automatic process, which compares actively incoming stimuli (sounds) to a sensory memory trace of previous sounds (Luck, 2005). MMN has been used extensively in first language acquisition research with neonates and infants. Typically, behavioural research on speech perception in babies focuses on preferential looking or sucking rate (for example, Vouloumanos et al., 2010; Werker et al., 1998). However, such methods are sometimes difficult to quantify and their interpretation has, at times, caused controversy (Cheour et al., 1998). An example of research using ERPs and the MMN is looking at how children's perception of phonological categories changes with age and development. Initial behavioural reports indicated that until about 1 year of age, infants are sensitive to all kinds of phonemic distinctions, whether they are present in their native language or not (Werker & Tees, 1984). Research involving ERPs has replicated those findings. In adults, a smaller MMN is elicited to vowel categories, which are not present in their native language (Näätänen et al., 1997). When comparing Finnish babies, they showed a larger MMN to /õ/ found in Estonian language at the age of 7 months, than at the age of 11 months (Cheour et al., 1998). Additionally, the MMN elicited by the 11 month old babies to the Estonian /õ/ was smaller than the MMN elicited by their peers for whom Estonian was a native language. Therefore, a conclusion can be drawn that infants become less sensitive to their non-native phonemic distinction as they grow. This example illustrates how ERPs can be used in language research with infants.

3. Pros and cons of using ERPs in language research

3.1 Advantages

ERPs, because of their good temporal resolution, are useful in language research because language processing happens at a very fast pace. Individual words are recognised in much less than half a second, and a difference between a /d/ and a /t/ can be recognised in just a few milliseconds because it comes down to a difference in voicing onset (Kaan, 2007). Only a method with an excellent temporal resolution can provide some insight into how language processing unfolds over time.

ERPs are particularly useful when working with clinical populations, such as individuals with aphasia, or infants and children. It is a technique that enables researchers to present the stimuli in spoken form, rather than in writing. Additionally, participants are not required to perform an extra task, again making it particularly useful when testing special populations. For example, in studies involving language comprehension, it is possible to assess the processing of a particular word, which might appear in the middle of the sentence. In classic behavioural experiments, it is necessary to wait until the sentence is fully presented for participants to make a response, thus relying on their memory. By that time, a number of cognitive processes are involved and it is not possible to accurately determine their effect. In experiments where an overt response by participants is needed, it is possible to establish which stage of processing is affected by a particular experimental manipulation, from the stimulus presentation to the response.

This technique allows for the collection of continuous data, with very good temporal resolution. In many language experiments, the sampling rate (defined as the rate at which the waveform data is sampled so that it can be changed to a numerical format) is between 250 and 512 Hz (samples every second), which is in line with a rate of language comprehension and therefore enables the continuous online processing.

The ERPs are multidimensional, allowing researchers to draw conclusions about the type of processes involved and their relationship. An example might be studies involving the RTs and self paced reading. In those cases, we don't know why people might struggle with reading, whereas with the ERPs we can say whether they are struggling with, for example, the semantics or syntax, as those are different components responsible for different processes and they are easily distinguishable in the ERPs.

Another advantage is that the effects can be seen almost immediately upon presenting participants with a particular, for example semantic, manipulation. Additionally, every single stimulus, not just targets, can be time locked in ERP research, thus providing not only instantaneous, but also continuous look at language processing.

Finally, the cost of ERPs is important. ERPs are rather inexpensive, compared to other techniques. Whilst the cost of testing a single participant in the fMRI experiment was valued to be up to \$800, the ERP session for each person was at \$1-3 (Luck, 2005).

3.2 Disadvantages

One of the main drawbacks of EEG research is the number of trials needed in an experiment. It is essential to have a large number of stimuli in each condition presented to participants, usually at least 40, because an individual ERP signal is such a small part of the continuous EEG recording that we need a larger sample size in a number of participants for meaningful interpretations. The exact number depends on the number of things, but typically in sentence processing studies involving 20 participants, a minimum of 40 trials is needed in each condition (Kaan, 2007). This in itself can create a number of further problems. Firstly, the time it takes to prepare the stimuli. Stimuli used in experiments have to be closely matched on a number of characteristics, such as word length, familiarity, imageability, amongst many others. Creating a set of such stimuli will take time, especially given that it is advisable that no stimulus is presented more than once to the same participant. Instead, different sets of items are created, and

these are counterbalanced across participants to ensure that all versions of the stimuli are presented the same amount of time throughout the experiment, but no participant is presented with the same version of a stimulus more than once. It can be very time consuming, especially in experiments that have a number of different conditions. Kaan (2007) suggests that in a study with 4 different conditions, it can take over a year to prepare a well-matched set of stimuli. Secondly, the large number of trials means longer experiments, especially if more conditions are needed, and that means tired participants. This leads to a number of difficulties, such as possible alpha waves, participants paying less attention to the task, poor concentration, employing different processing and coping strategies, more missed trials, and so on. It is important to remember that poor quality data leads to more noise, which in turn leads to more trials that might need to be rejected. Another important aspect is the human factor. Participants can often get tired and fed-up with long, monotonous studies. That is why frequent breaks are advisable. It is thought that blocks lasting 5-7 minutes, separated by a short break, are optimal (Luck, 2005). Thirdly, a large number of trials often lead to more artefacts and more trials that will have to be removed. Eye blinks, muscle movements, accidental head turns, even swallowing can create artefacts which will affect the ERPs. Some researchers choose to give specific instructions to participants, such as asking them to blink only at specified times, for example after they have made a response and never during, whilst others choose to refrain from such specific instructions because it can affect participant's attention and quickly lead them to be fatigued. A mathematical method, such as that proposed by Gratton et al. (1983) can be applied to the data in order to correct for the distortion of eye blinks, which can be especially useful in special populations, where specific instructions often cannot be given. However, using such method also has some drawbacks (Luck, 2005). A large number of trials makes it impractical for the ERPs to be used in certain experiments, such as those in which each participant can only receive one trial in each condition (Luck, 2005).

Another possible disadvantage of using ERPS is the poor spatial resolution. ERPs show a good temporal resolution, but it is difficult to say where in the brain the activity occurs. Poor spatial resolution is a result of limited spatial sampling, contamination of

the reference electrode, and the smearing by the head volume conductor, and inability to actively use the information about the volume conductor (Nunez et al., 1993).

In sentence processing experiments involving visual presentation of stimuli, it is not advisable to present the whole sentence on the screen at once because of the eye movements. Also, because it would not be possible to time lock the ERPs to our target stimuli, sentences are usually presented on a word-by-word basis. This leads to a relatively slow stimuli presentation rate, usually of 500ms interval from the presentation of one stimulus to the presentation of another. This is different from typical reading and can therefore add some load to working memory and may introduce a confound (Kaan, 2007). However, results from experiments investigating natural speech are comparable with those using visual presentation of stimuli (Kaan, 2007).

In comparison with classic behavioural studies, the interpretation of ERPs is less clear and requires much more inferences. For example, in a RT behavioural experiment in which participants took 30ms longer to press the button in condition 1 than in condition 2, it is reasonable to say that the time to process and perform an action takes this much longer in condition 1 than 2. However, in ERPs when peak latency is later in condition 1 in comparison to condition 2, it is difficult to draw a conclusion without making many assumptions and inferences (Luck, 2005).

Despite those possible limitations, using ERPs in language research has proven to be popular and valuable and has added a great depth of knowledge to how language is processed in the human brain in real time.

4. Conclusions

The choice of using ERPs in the present thesis has been dictated by its ability to directly measure real-time brain activity, especially without the need for an additional task (this particular advantage has been used in the experiment in Chapter 5, which investigated the possible automaticity of semantic priming in early, balanced bilinguals). It is clear

that ERPs can highlight the temporal unfolding of neural activity associated with different cognitive aspects of language comprehension and production.

Chapter 4

Translanguaging:

A new strategy to boost human learning.

Abstract

Bilingual education has witnessed a major shift towards mixing two languages in the classroom. Observations of bilingual children's learning show a tendency to spontaneously engage in 'translanguaging', that is, the production of an output of their learning in a language different to that of instruction. To date, however, no quantitative evidence is available to assess the effectiveness of such strategy for improving access to newly established knowledge. Here we show that new semantic representations laid in a translanguaging context are more readily accessible from long-term memory than the same representations acquired in a monolingual context. We tested Welsh-English bilinguals using a novel-object learning paradigm whilst manipulating the learning context between experimental blocks: monolingual (reading and naming in English) or translanguaging (reading in English, naming in Welsh). After completion of the learning phase, we assessed semantic access during picture-picture priming with event-related brain potentials. As expected, semantic priming overall reduced N400 amplitude for related picture pairs, but, critically, novel objects learned through translanguaging elicited reduced N400 amplitude as compared to novel objects learned in monolingual context. This main effect of translanguaging on N400 amplitude shows overall greater availability of semantic representations for learning that involves both a language change and a switch from comprehension to production. We also retested participants 2-4 weeks later and found long lasting effects of translanguaging even when the semantic priming effect had started to wear off. These results provide the first neuroscientific evidence that learning is enhanced when semantic representations are laid in a translanguaging context, paving the way to more effective strategies in bilingual education.

Keywords: translanguaging, bilingualism, bilingual education, N400, semantic integration, event-related brain potentials.

Introduction

Today bilingualism is much more common than monolingualism, and across the globe communicating using more than one language is the norm. The intense globalization and the growth of bilingualism has led many scholars, educators, and government bodies to seek the expansion of the previous teaching and learning strategies in order to accommodate the needs of the fast-growing bilingual societies.

The concept of bilingual schooling, although by many perceived as something new, and which indeed had not received much attention and research focus until the mid 20th century, in fact goes back at least 4000 or 5000 years (Mackey, 1978). From a historical perspective, bilingual schooling has always been considered desirable for the education of children from middle and upper classes of society (Lewis, 1977). From the 2nd century onwards, for instance, boys coming from Roman aristocratic homes were expected to learn the language of the then-admired Hellenic civilization, and therefore their education was conducted in Greek and Latin. With the emergence of technology and intense globalization over the last couple of decades, there has been a need to develop new teaching and learning strategies that would account for the fast-changing multilingual society. In recent years, there has been a major shift in the way we approach bilingual education. García (2009) argues that children throughout the world most frequently engage in what she calls ‘translanguaging’. Translanguaging is a relatively new term, first coined by Cen Williams (1994a) in Wales to describe teaching and learning strategy in which students receive information in one language, and are encouraged to produce it back in their other language. It can, for example, include preparing a poster in Welsh, and describing it to classmates in English, or researching something online in English (which is very frequently done these days) and using this information in another language. For a more detailed overview of translanguaging, please refer to Chapter 2.

It is difficult to put translanguaging into a context of wider research, since despite the last 20 years of translanguaging in practice, no quantitative studies have been conducted

that would establish the potential benefits of this learning strategy. One issue has to be discussed though, and it relates to people frequently confusing ‘translanguaging’ with simple ‘language-switching’. People who know more than one language frequently alternate (‘code-switch’) them within a discourse or within a sentence, especially when other bilinguals are also present. Historically, code-switching, a linguistic repertoire whereby bilingual individuals use their two languages intrasententially or intersententially (Cook, 2001), has not been a welcomed activity in schools, mainly due to the belief that engaging in such activity shows gaps in knowledge (Reyes, 2006). Schools typically aimed to have the two languages clearly separated, and pupils were encouraged to only use the ‘target’ language within the lessons. Also from a sociological perspective, it was argued that within a bilingual society, languages should be kept strictly separate in order to allow the language maintenance of an ethnolinguistic group (Fishman, 1972 in García, 2009). It was assumed that mixing two languages would lead to cross-contamination, and that the disadvantage for students that comes from mixing two languages is so obvious, that it does not require any research and scientific evidence (Jacobson & Faltis, 1990). For decades, language policies and bilingual education planning has come from those early assumptions, which has kept the languages strictly separate during learning. Over time, it has been accepted that the ability to code-switch is not an unwelcome phenomena and rather than showing gaps in vocabulary or knowledge, it serves a range of different purposes in the bilingual environment, such as being able to express themselves better (Zentella, 1997) or being able to perform cognitively-demanding tasks (Reyes, 2004). In fact, some researchers argue for the use of code-switching in the schools (Creese & Blackledge, 2010). Lin and Martin (2005) argue for pedagogic potential of code-switching, which extends to inclusion of all students, increased participation, and better understanding of students and their knowledge and abilities. From the cognitive perspective, so all the positive social and emotional values aside, switching languages does produce some cognitive demands. It has been shown that the speed of both comprehension and production of bilinguals are affected in mixed-language tasks, especially when such switch is unexpected and unpredictable (Thomas & Allport, 2000; Meuter & Allport, 1999; Grainger & Beauvillain, 1987; Dalrymple-Alford, 1985; Soares & Grosjean, 1984). It is perhaps not

surprising, then, that many educators have been cautious about allowing language-switching in their classrooms in the fear of somehow making the students' education more difficult. However, translanguaging is not the typical code-switching and has more to do with the long-term effects of using a strategy of simultaneous language- and modality- switch.

Therefore, translanguaging certainly encompasses code-switching, but goes far beyond the language change and taps into purposeful and naturally occurring practices carried out by bilinguals. While code-switching suggests switching between two static language codes, translanguaging is a new phenomena, independent of any codes that through a new and open 'languaging' has the power to give voice to new social realities (García, 2009). It is a pedagogical practice aimed to encourage deeper understanding of the subject, achieved by having to fully understand the topic in one language before being able to discuss it another. It aims to help pupils in gaining deeper understanding of the subject, shape experiences, and make meanings (Lewis et al., 2012). Ofelia García, who has popularised the term globally, emphasises that translanguaging is a strategy when two or more languages are used in a flexible way in order to make sense of the world. She argues that bilingualism in the 21st century is not compartmentalized, balanced or linear, and instead is flexible, dynamic, and fluid (García, 2011). Through translanguaging, bilingual individuals themselves can decide when and which language features they should access in order to meet their communicative needs and allow them to fully participate in the globalized, multilingual and flexible society. It therefore allows individuals to fully benefit from the permeability of learning and functioning in two languages simultaneously (Park, 2013).

Although there have been some promising qualitative reports on the benefits of translanguaging, so far it has not been measured quantitatively. Here, we have set out to establish the effects of translanguaging in its original form, that is when information is heard/read in one language, and produced in another. We have decided to use ERPs as a methodology of choice, focusing on the N400 component, known to index semantic integration effort (Kutas & Hillyard, 1980; see Kutas & Federmeier, 2011, for a review)

in a semantic priming paradigm. It has been found that a recognition of a target is facilitated when it is preceded by a semantically related, rather than unrelated, prime (see McNamara & Holbrook, 2003, for a review). The N400 component of the ERPs has been found to be sensitive to priming paradigms, where semantic content of the stimuli is manipulated. The N400 is attenuated to targets that followed semantically related, rather than unrelated primes (see Chapter 3 for more information on the ERPs and the N400; see Kutas & Federmeier, 2011, for a review of the N400 component). We expected to see the well-established modulation of the N400 by relatedness. Additionally, we were interested in observing any potential effects of translanguaging on the N400, with the aim to establish the effects it might have on people's ability to integrate newly acquired information. We designed a study that enables a direct comparison of learning through translanguaging with acquiring that same information monolingually.

Methods

Participants

Thirty-four Welsh-English bilingual adults with normal or corrected-to-normal vision and no known reading difficulties confirmed in writing that they were early, balanced bilinguals with exposure to both of their languages from early childhood (before starting school). The study was approved by the Ethics Committee at Bangor University, and all subjects gave written consent before testing. Participants were compensated £20 or course credits for their time. Data from 10 participants were discarded from the study owing to poor data quality or insufficient number of artefact-free trials. This exceptionally high attrition relates mainly to the fact that the study involved seven sessions in total, which represents a substantial commitment on the part of the participant and increases the likelihood of poor data quality. In the end, 24 datasets were included in the analyses (7 males, 17 females, mean age: 24.9years).

Due to the balanced and frequent exposure at home, school and the general environment to both Welsh and English from birth, which characterised our participants, it is impossible to determine which language is 'dominant' or 'native', and which is the

‘second language’. Therefore, we have decided not to refer to our participants’ languages as L1 and L2, and instead refer to Welsh and English (see Perea et al., 2008; and Guasch et al., 2011, for a similar decision in the case of their Basque-Spanish and Catalan-Spanish bilinguals, respectively).

Stimuli

We selected colour pictures from in house or online databases depicting 80 novel and 80 familiar objects. Novel objects were very unlikely to have been encountered before by participants (and novelty was checked at debriefing). Each picture measured 558x360 pixels and subtended a visual angle of less than 8 degrees. Eighty novel definitions were created using highly familiar words, and were between 6 and 9 words in length, using the same syntactic frame (Verb-object, see Table 1, below, for examples).



	Used to communicate orders in ships.
	Used to make sugar roses to decorate cakes.
	Used to colour strands of hair.

Table 1. Examples of the stimuli used in the present experiment.

Procedure

Overall the entire experiment consisted of seven phases, that is 5 blocks in a first session (Time 1) and 2 repeat blocks in an additional session (Time 2) conducted 2-4 weeks after the first one.

In session 1, phase 1 involved **familiarization** (first viewing of the novel objects and familiarisation with the pictures of known objects); phase 2 involved **learning** (novel objects were presented along with their definition and semantic associations were first established); phase 3 involved **extended learning** (semantic associations between novel

and familiar objects were tested and consolidated); phase 4 was the **ERP priming test** (novel objects and familiar objects were presented in a traditional picture-picture priming paradigm); phase 5 was a **qualitative matching** task (definitions were presented and participants selected the corresponding novel object from an array of four).

In session 2, participants were re-tested on phase 4 and 5 on the back of a new invitation to participate without any familiarisation, training or forewarning.

Phases 1-3 were presented in 4 consecutive blocks dealing with 20 associations of novel objects, definitions, and familiar objects. Each block included:

- **Familiarization** (Phase 1): participants viewed 20 familiar objects (labelled either in English (in the monolingual block) or Welsh (in the translanguaging block)) and 20 novel objects (labelled with a string of Xs, since they have no label associated with them) presented in the middle of a 19" CRT monitor over a white background in a pseudo-randomised fashion for a duration of 450-700 ms (mean = 575 ms) each. Participants were asked to detect *catch trials* in which familiar pictures were presented with a string of Xs (rather than with their actual name) by pressing the space bar. There were 4 catch trials per block. Please see figure 4 (below) for a schematic representation of phase 1.

Phase 1 - Familiarisation

Phase 1 – Familiarisation (Monolingual blocks)

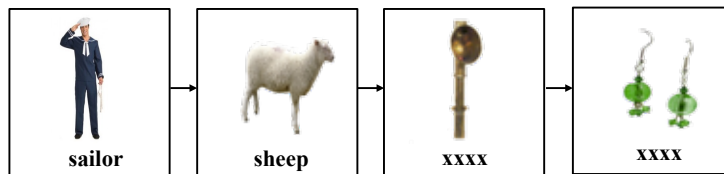

Catch trial* → press the space bar

* Catch trial – because the picture was labeled with a series of 'xxx' rather than with an actual noun (here, *earrings*)

Phase 1 – Familiarisation (Translanguaging blocks)

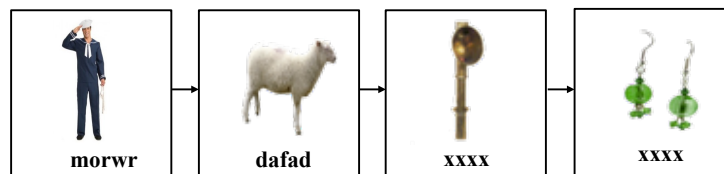

Catch trial* → press the space bar

* Catch trial – because the picture was labeled with a series of 'xxx' rather than with an actual noun (here, *clustdlysau*)

Figure 4. Visual representation of phase 1 for both the monolingual (top) and translanguaging blocks (bottom), separately.

- **Learning** (Phase 2): novel objects were presented individually for 1500 ms in the middle of the screen, followed by the definition in English (in both monolingual and translanguaging blocks), all at once, in 18 points Helvetica font for 1500 ms. Next, the novel object disappeared and 4 familiar objects were presented in a 2 x 2 array. Participants were asked to name out loud the familiar object that related to the previously seen novel object via its definition. Naming was done in English (monolingual block) or Welsh (translanguaging block). Upon verbal response, participants received visual feedback on the screen, manually delivered by the experimenter and indicating 'correct' (green tick mark), 'incorrect' (red cross) or 'misnaming', that is choosing the correct picture but using the incorrect word for it (such as saying *a man* instead of *a sailor*). In the case of misnaming, there was a redisplay of the 2 x 2 familiar picture array (for 1500 ms), indicating that participants should try again, using the correct noun. Failure to name the correct familiar object (incorrect trial) initiated a second presentation of the novel object together with its definition, for 1500 ms,

followed by the 2 x 2 familiar object array requiring a verbal response. Please see figure 5 (below) for a schematic representation of phase 2.

Phase 2 - Learning

Phase 2 – Learning (Monolingual blocks)

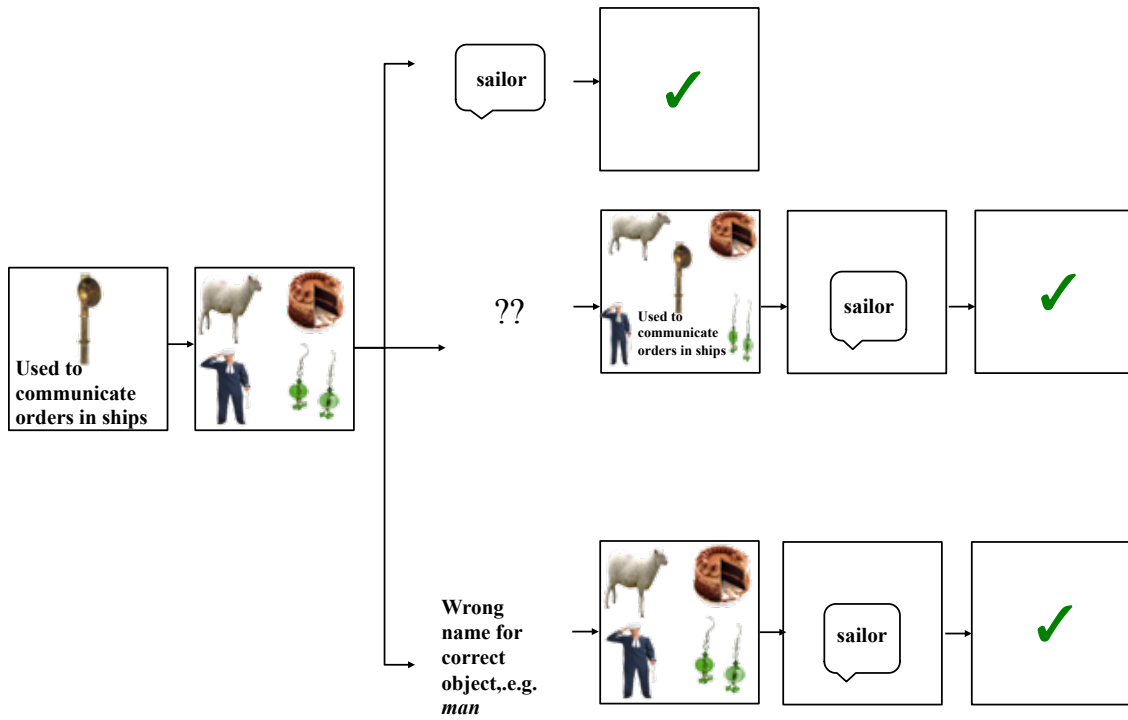

Phase 2 – Learning (Translanguaging blocks)

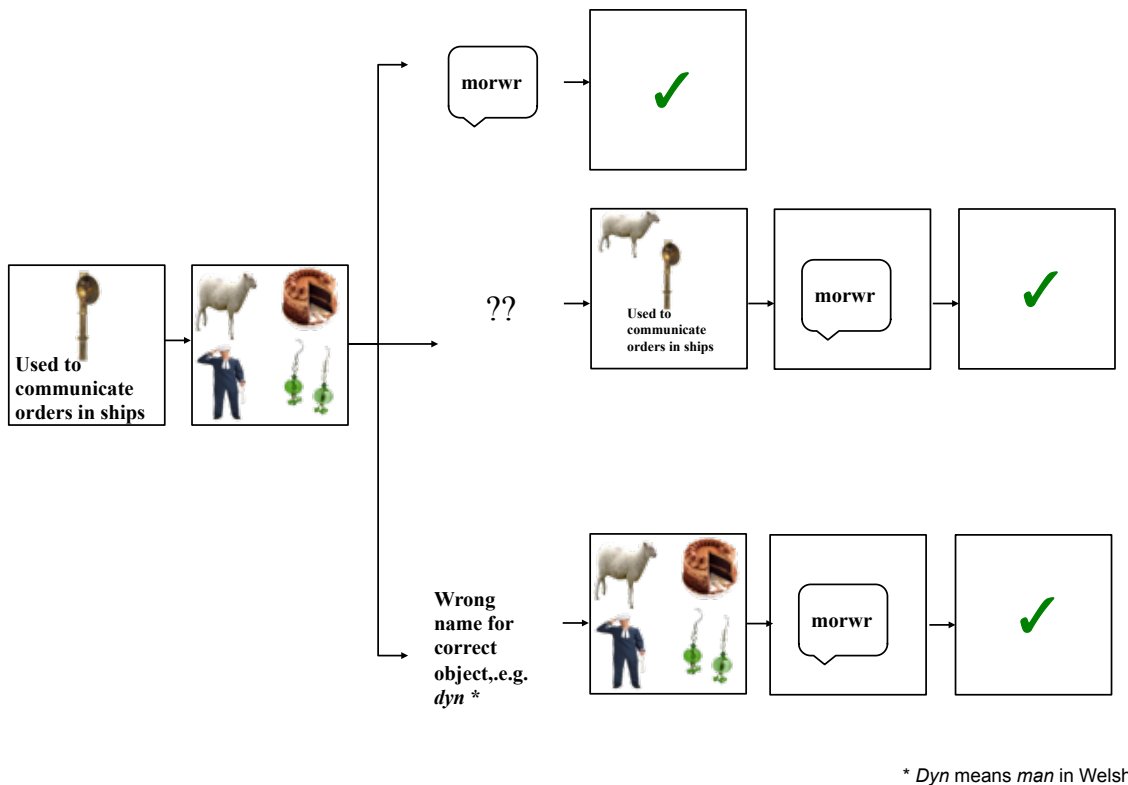
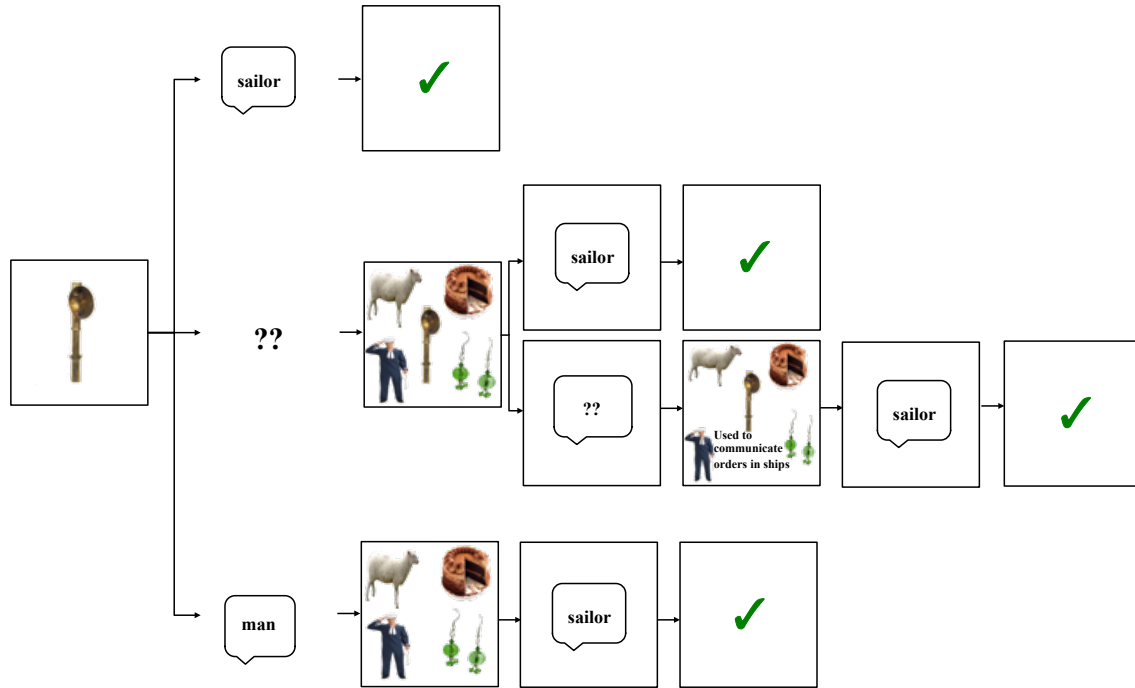

Figure 5. Visual representation of phase 2. The top picture represents Phase 2 in monolingual blocks, whereas the bottom picture represents Phase 2 in translanguaging blocks.

- Extended learning (Phase 3):** the novel objects were displayed in the centre of the screen, on their own (with no associated definitions), for up to 10 seconds and participants were asked to retrieve from their memory the name of the familiar object associated with the presented novel object via the definition learned in the previous phase. Upon verbal response, participants received visual feedback, manually delivered by the experimenter and indicating ‘correct’ (green tick mark) or ‘incorrect’ (red cross). Failure to produce the name for the familiar object (incorrect trial) initiated a repeat presentation of the familiar object array for 1500 ms requiring a corrected verbal response. If participants then named the correct familiar object, the next trial was initiated. If they failed to produce the correct familiar name when prompted the second time, the definition was displayed in the middle of the screen together with the familiar object array and feedback was given accordingly. Novel objects were randomly

presented for a maximum of 8 times and were dropped when participants correctly named the target familiar object twice in separate trials, with no help from the experimenter. In the monolingual blocks, participants named the familiar object in English (after reading a definition in English) and in the translanguaging blocks, in Welsh (after reading a definition also in English). Block order and language of naming was fully counter-balanced between participants. Therefore, those same objects that were learned monolingually in half of the participants, were then used in the translanguaging blocks for the other half of subjects, and *vice versa*. Please see figure 6 (below) for a schematic representation of phase 3.

Phase 3 – Extended Learning



Phase 3 – Extended Learning (Translanguaging blocks)

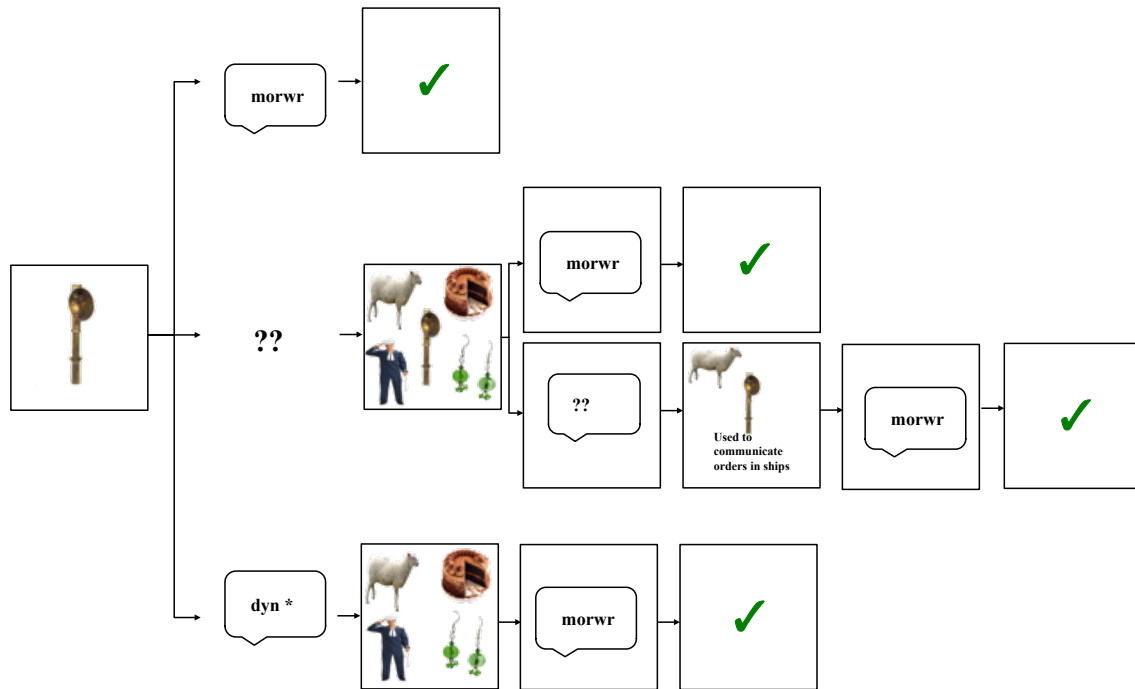

* Dyn means man in Welsh

Figure 6. Visual representation of phase 3. The top picture represents Phase 3 in monolingual blocks, whereas the bottom picture depicts Phase 3 in translanguaging blocks.

After completing the 4 **Familiarization-Learning-Extended learning** blocks (2 monolingual and 2 translanguaging), participants were tested in two blocks corresponding to phases 4 and 5:

- The **ERP priming test** (Phase 4): involved a classic nonverbal picture-picture priming paradigm. All novel objects were presented in the middle of the screen for 450-700 ms, followed by a related or unrelated familiar object according to learned definitions, displayed for 2000 ms or until participants' response. All novel objects were presented twice, once with a related familiar object, and once with an unrelated familiar object. This resulted in 160 trials: 40 related and 40 unrelated learned monolingually, 40 related and 40 unrelated learned through translanguaging. Please see figure 7 (below) for a schematic representation of phase 4.

Phase 4 – ERP Testing

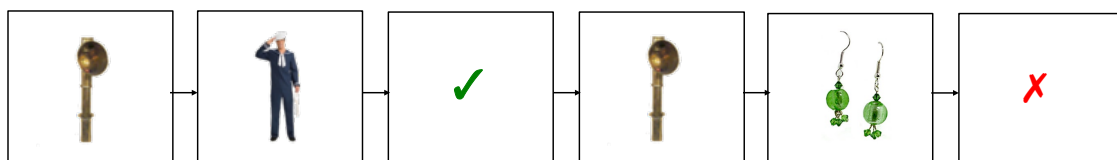

Figure 7. Visual representation of phase 4. All previously presented objects, whether they were learned in monolingual or translanguaging blocks, were mixed up and presented together in this phase.

- The **qualitative matching task** (Phase 5): focused on behavioural testing of participants' explicit knowledge. This phase did not require ERP data, and was conducted after the participants had removed the cap and washed their hair. In each trial, participants were shown a definition of a novel object together with an array of 4 novel objects labelled 1-4 (which stayed on the screen until they made a response). Participants had to indicate (using keyboard keys 1-4) which

of the novel objects matched the definition. Please see figure 8 (below) for a schematic representation of phase 5.

Phase 5 – Behavioural testing

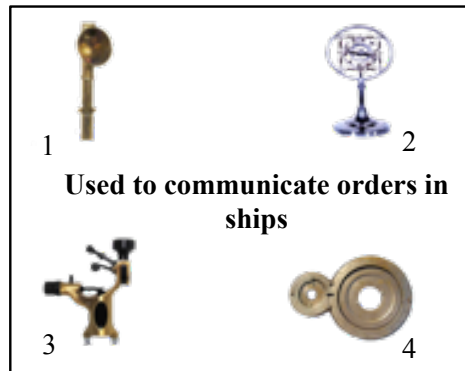

Figure 8. Visual representation of phase 5. All previously encountered novel objects, whether they were learned in monolingual or translanguaging blocks, were mixed up and presented together in this phase.

Participants were asked to come back 2-4 weeks later (~19 days on average) for re-testing involving the ERP priming test (Phase 4) and the qualitative matching task (Phase 5). They were not explicitly told that they would be tested again on the same task in order to ensure that they do not practice what they had learned in the meantime. Only 16 datasets were retained after re-testing due to poor data quality or participants failing to return within the required period.

Electrophysiological recording

EEG data were continuously recorded using Neuroscan 4.4 (Neuro-Scan 4.4, Charlotte, NC) in reference to the Cz electrode at the rate of 1 kHz from 64 AG/AgCl electrodes mounted in a cap (EasyCap™) according to the extended 10/20 system (Jasper, 1958). One additional electrode was attached below the right eye and another additional one on the side of the right eye, in order to monitor for participants' eye-blinks and horizontal eye movements. EEG signals were filtered offline with a 30Hz low pass zero phase shift digital filter. Eye-blink artefacts were mathematically corrected using an algorithm provided in NeuroScan 4.4, which is based on the Gratton et al.'s (1983) method.

Continuous EEG data was then used to create epochs ranging from -100 before the presentation of the target stimulus, to 1000ms after its presentation. ERPs were created by averaging the epochs, time locked to the target stimulus presentation. Individual averages were re-referenced to the global field power produced over the entire scalp. Impedances were kept below 5KOhm.

No full-scalp analyses were conducted. This is because the modulation of the ERP components was predicted to be strongest in the region of interest and thus the statistical analyses of the mean amplitude of the N400 were performed in the electrodes previously determined (predictive approach), based on the extensive N400 literature available to date (see Kutas & Federmeier, 2011, for a review). Mean amplitudes were then used in repeated measures 2 x 2 ANOVA, with relatedness (related, unrelated) and learning context (translanguaging, monolingual) as factors.

Results

Behavioural results

An overview. Analyses for Phases 3-5 are presented in this section. Data analysis was subjected to repeated measures ANOVA. These represent the time taken to consolidate the associations between the novel and the familiar objects (Phase 3), and the ability of the participants to recall these associations when cued (Phases 4 and 5). In Phase 3 the total number of trials taken to complete the phase within each block is the main measure of interest; this measure has a theoretical lower limit of 40, since each novel object had to be named correctly twice with no hints from the experimenter. In Phase 4, response times and accuracies of each trial were recorded. In Phase 5 only accuracy was measured.

Time 1

The measure in phase 3 (extended learning) is the duration (number of trials) for each participant needed to complete the monolingual and translanguaging blocks. The minimum would be 40 trials in each block (since each trial must be seen at least twice). A repeated measures Analysis of variance (ANOVA) analysis showed that participants took slightly longer to complete the translanguaging, rather than the monolingual, blocks [$F(1,23) = 5.091, p = 0.034$].

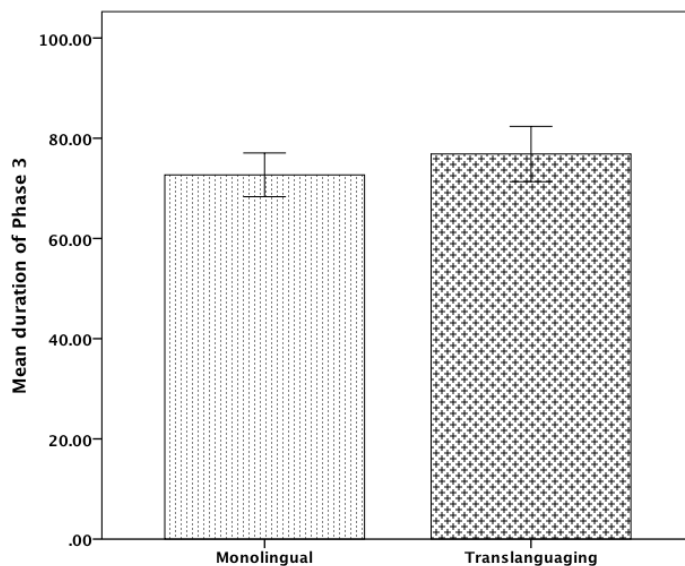

Condition	Mean	St.Dev.
Monolingual	72.695	10.102
Translanguaging	76.847	12.742

Table 2. Overall data for performance in Phase 3 (Extended Learning) in the monolingual and translanguaging learning contexts.

Figure 9. Bar graph representing participants' performance during the extended learning phase (Phase 3). Participants took slightly longer to complete the translanguaging block, rather than the monolingual.

In Phase 4 (ERP testing phase) mean reaction times differed slightly between the conditions for stimuli learned in monolingual versus translanguaging learning contexts. Participants were slower to respond to objects learned in a translanguaging, rather than a monolingual context, [$F(1,23) = 5.078, p = 0.034$].

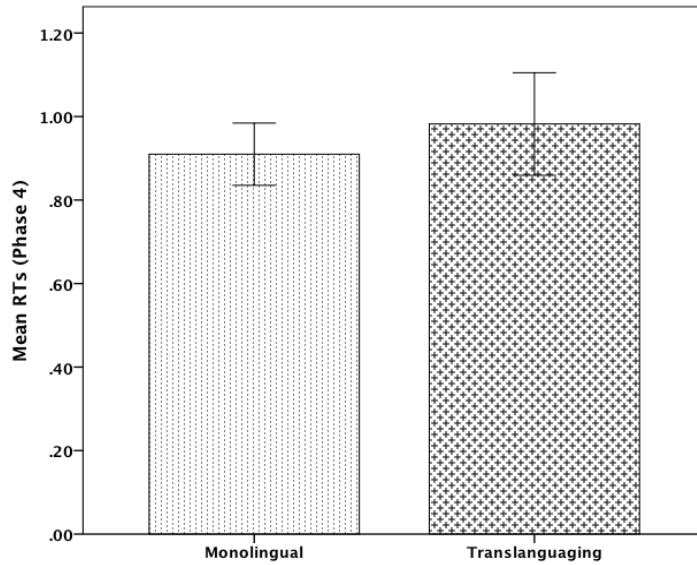

Condition	Mean	St.Dev.
Monolingual	0.909	0.176
Translanguaging	0.982	0.290

Table 3. Overall data for reaction time performance in Phase 4 (ERP testing) in the monolingual and translanguaging learning contexts.

Figure 10. Bar graph representing participants' reaction times (RTs) in milliseconds during the ERP testing phase (Phase 4). Participants took slightly longer to respond to pictures learned in a translanguaging, rather than monolingual, block.

Also in Phase 4 (ERP testing), there was no difference between the monolingual and translanguaging blocks in terms of the accuracy of participants' responses, [$F(1,23) = 0.109, p = 0.744$]. The errors made by the participants, in both monolingual and translanguaging blocks, referred to the participants not being able to correctly identify whether the presented picture pairs were related in meaning or not, according to the previously learned definitions.

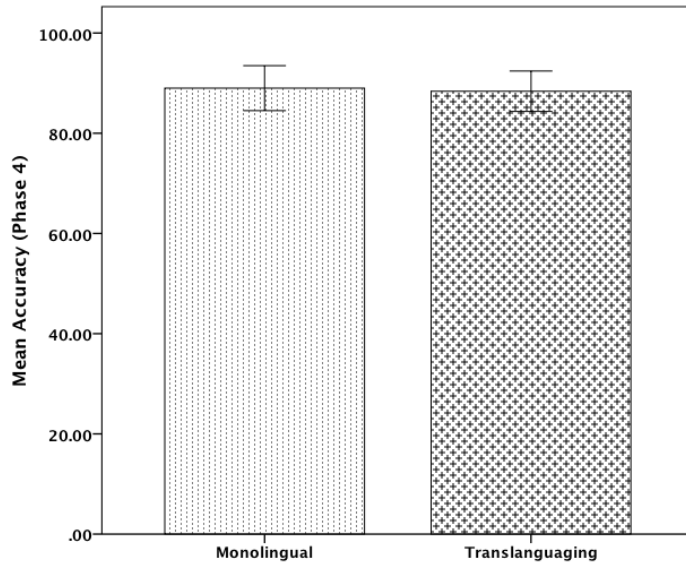

Condition	Mean	St.Dev.
Monolingual	89.010	10.632
Translanguaging	88.385	9.565

Table 4. Overall data for accuracy in Phase 4 (ERP testing) in the monolingual and translanguaging learning contexts.

Figure 11. Bar graph representing participants' accuracy (Acc.) during the ERP testing phase (Phase 4). Accuracy here refers to participants being able to correctly identify whether the picture-pairs were related or not. There was no difference in their performance between the two learning contexts.

Phase 5 measures were taken soon after the participants' had completed the ERP session. Translanguaging items were recalled slightly less accurately after a short delay than monolingual stimuli, [$F(1,23) = 6.214, p = 0.021$].

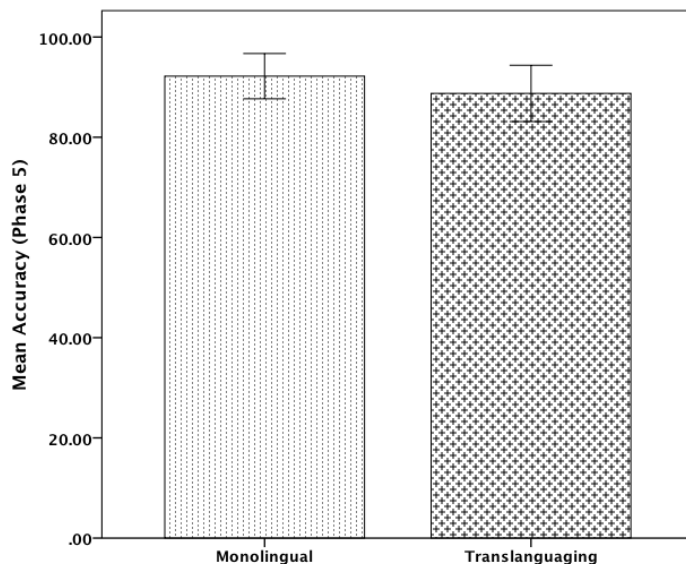

Condition	Mean	St.Dev.
Monolingual	92.195	10.456
Translanguaging	88.710	13.010

Table 5. Overall data for accuracy in Phase 5 (behavioural testing) in the monolingual and translanguaging learning contexts.

Figure 12. Bar graph representing participants' accuracy (Acc.) in the behavioural-only testing phase (Phase 5). Participants recalled items learned in a translanguaging learning

context slightly less accurately than those they learned in monolingual blocks, meaning that they had more difficulties correctly recalling those pictures, which were first encountered and learned in a translanguaging, rather than monolingual, blocks.

Time 2 (2-4 weeks later)

Overall, there were no differences in participants’ performance when they were tested a few weeks after the initial experiment took place. 16 participants from the initial group of 24 were included in the analysis.

This time, there was no data for Phase 3 (Extended Learning) recorded, because participants were not subjected to any learning procedures. Instead, they were tested on the same ERP priming paradigm (Phase 4), and the behavioural testing at Phase 5.

In Phase 4 (ERP testing), there were no differences between the conditions in terms of participants’ mean reaction times, [F(1,15) = 2.990, p = 0.163].

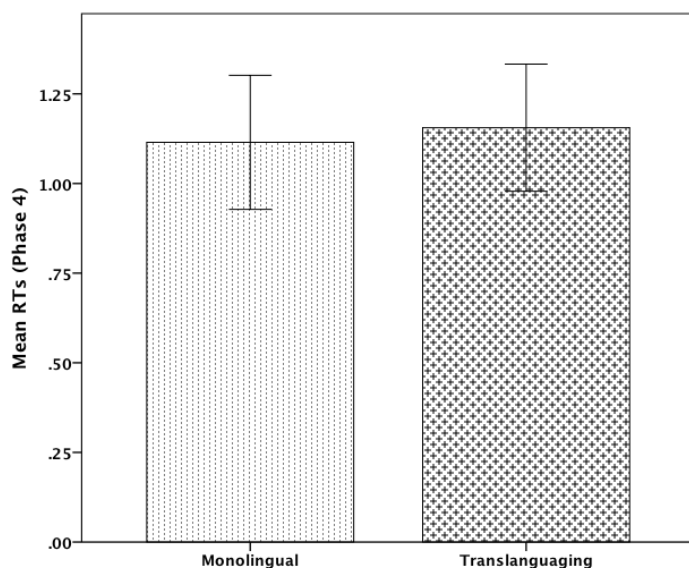

Condition	Mean	St.Dev.
Monolingual	1.114	0.323
Translanguaging	1.155	0.307

Table 6. Reaction time data for participants’ performance in Phase 4 (ERP testing) in the monolingual and translanguaging learning contexts.

Figure 13. Bar graph representing participants’ reaction times in Phase 4. There were no differences between the conditions. Accuracy here refers to participants being able to correctly identify whether the picture-pairs were related or not.

In terms of participants' accuracy in Phase 4 (ERP testing), no differences between the two learning contexts were recorded [$F(1,15) = 3.307, p = 0.06$]. As with the results at Time 1, the errors made by the participants, in both monolingual and translanguaging blocks, referred to the participants not being able to correctly identify whether the presented picture pairs were related in meaning or not, according to the previously learned definitions. The types of errors made by the participants were comparable within the learning context (that is, monolingual and translanguaging) and across time (that is, at Time 1 and Time 2), and related to unsuccessful identification of related and unrelated picture pairs (that is, indicating that the presented picture pair was related in meaning when, in fact, it was not, or *vice versa*).

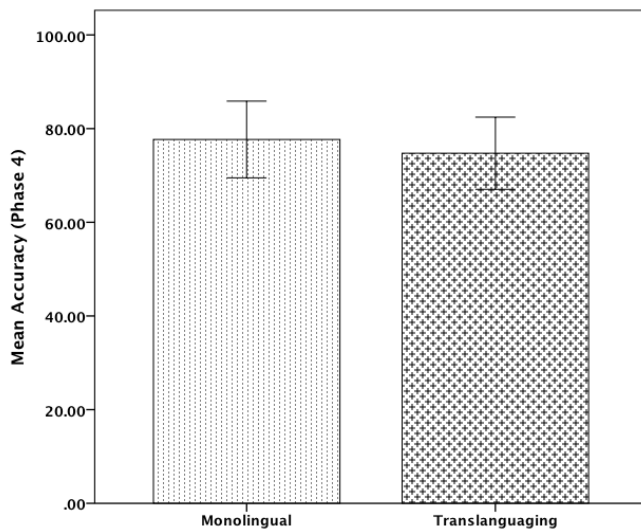

Condition	Mean	St.Dev.
Monolingual	77.678	14.347
Translanguaging	74.732	13.347

Table 7. Accuracy data for participants' performance in Phase 4 (ERP testing) in the monolingual and translanguaging learning contexts.

Figure 14. Bar graph representing participants' accuracy in Phase 4. There were no differences between the conditions.

Lastly, no differences in participants' accuracy to recall the objects from the monolingual and translanguaging blocks were recorded, [$F(1,15) = 5.973, p = 0.06$].

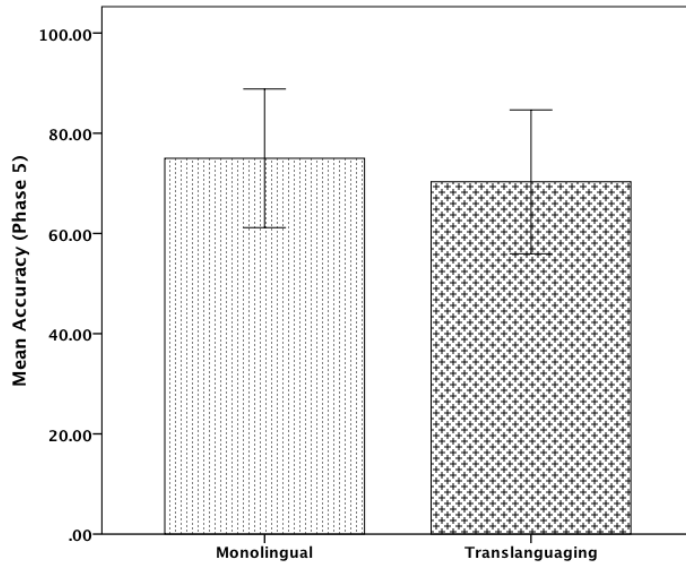

Condition	Mean	St.Dev.
Monolingual	74.991	23.951
Translanguaging	70.298	24.873

Table 8. Accuracy data for participants' performance in Phase 5 in the monolingual and translanguaging learning contexts.

Figure 15. Bar graph representing participants' accuracy in Phase 5. There were no differences between the conditions.

ERP results – the N400 modulation with semantic relatedness and learning context

As expected, the N400 effect was maximal at the 9 central electrodes (CP1, CP2, CPz, P1, P2, Pz, FC1, FC2, FCz), which were then selected for analysis, and peaked on average at around 370 ms. Time window selected was 300-440ms.

The analyses of the N400 component were conducted using a 2 x 2 factorial design, with factors of semantic relatedness (related, unrelated) and learning context (monolingual, translanguaging). Please see figure 16 for ERPs for the related and unrelated blocks, and monolingual and translanguaging learning contexts (Time 1), and figure 18 for Time 2.

Time 1

As expected, in line with the previous literature, the maximal N400 effect was obtained on the central electrodes. The following electrodes were chosen for the analysis: CP1, CP2, CPz, P1, P2, Pz, FC1, FC2 and FCz. Data from all of them were used when

performing statistical analyses. Figure 16 (below) shows the data only from one of those electrodes (here, Cz) as an example to illustrate the obtained results.

As predicted, there was a significant main effect of semantic relatedness (a difference in the N400 wave depletion to target objects preceded by related and unrelated picture), with related objects showing a more reduced N400 amplitude than unrelated, $[F(1,23)=10.733, p=0.003]$. Additionally, there was a striking significant main effect of the learning context (a difference in the N400 amplitude reduction to target pictures that were preceded by an object learned in a translanguaging as opposed to monolingual context), with picture pairs learned in the language alternation block showing significant reduction in the N400 compared to those learned in a monolingual fashion, $[F(1,23)=7.217, p=0.013]$. There was no significant interaction between semantic relatedness and learning context at, $[F(1,23)=0.174, p=0.680]$.

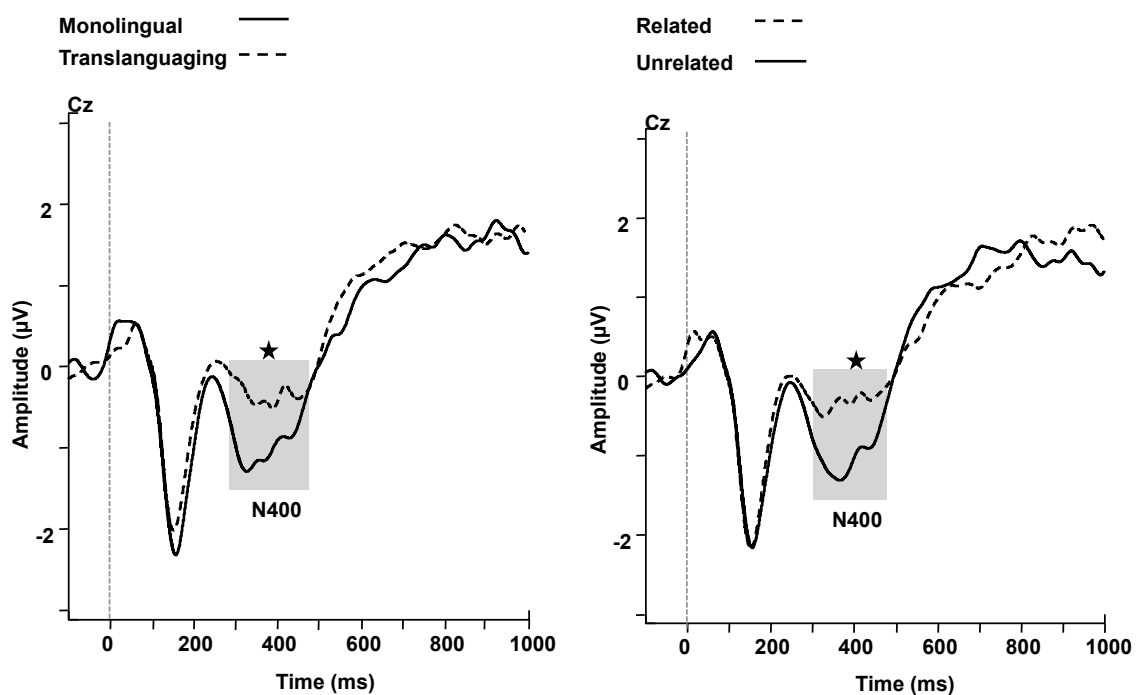

Figure 16. Grand average ERPs for related and unrelated items, and for monolingual and translanguaging learning contexts at Time 1. The above data shows the grand average ERPs only on one of the electrodes (Cz) as an example.

Below (Figure 17) we present the grand average ERPs on the electrodes that were used for statistical analyses (with the exception of Cz, which is enlarged and shown in Figure 16 (above) as an example).

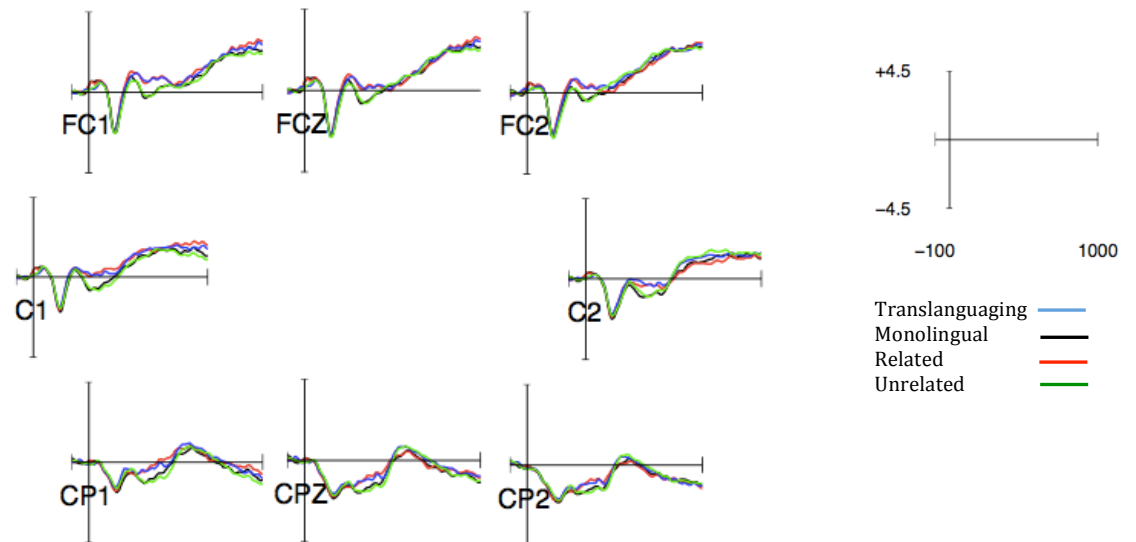

Figure 17. A view of the grand average ERPs on the channels chosen for the statistical analyses (with the exception of Cz, which is enlarged and shown above in Figure 16 as an example)

Below (Figure 18), we present topographical maps of the mean voltage amplitudes for the 300-440ms time window for learning context (monolingual, translanguaging) and relatedness (related, unrelated) conditions.

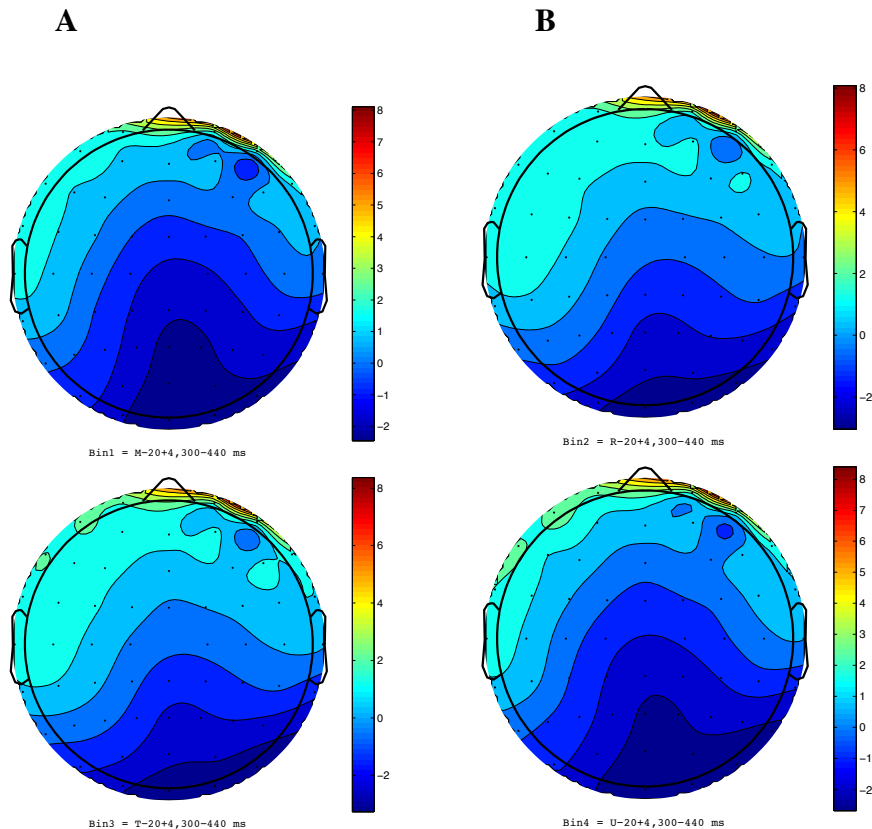

Figure 18. Topographical maps in response to monolingual (column A, top) and translanguaging (column A, bottom), as well as related (column B, top) and unrelated (column B, bottom) conditions. Time window: 300-440ms.

Time 2

As expected, in line with the previous literature, the maximal N400 effect was obtained on the central electrodes. The following electrodes were chosen for the analysis: CP1, CP2, CPz, P1, P2, Pz, FC1, FC2 and FCz. All of them were used when performing statistical analyses. Figure 19 (below) shows the data only from one of those electrodes (here, Cz) as an example to illustrate the obtained results.

The initial effect of relatedness had started to wear off, and after a few weeks it has failed to reach statistical significance, $[F(1,15)=0.746, =0.402]$. Surprisingly, the initial effect of the learning context was found to be long-lasting, and still significant 2-4 weeks after the initial testing, $[F(1,15)=7.280, p=0.017]$. There was no significant

interaction between semantic relatedness and learning context, [$F(1,15)=0.145$, $p=0.709$].

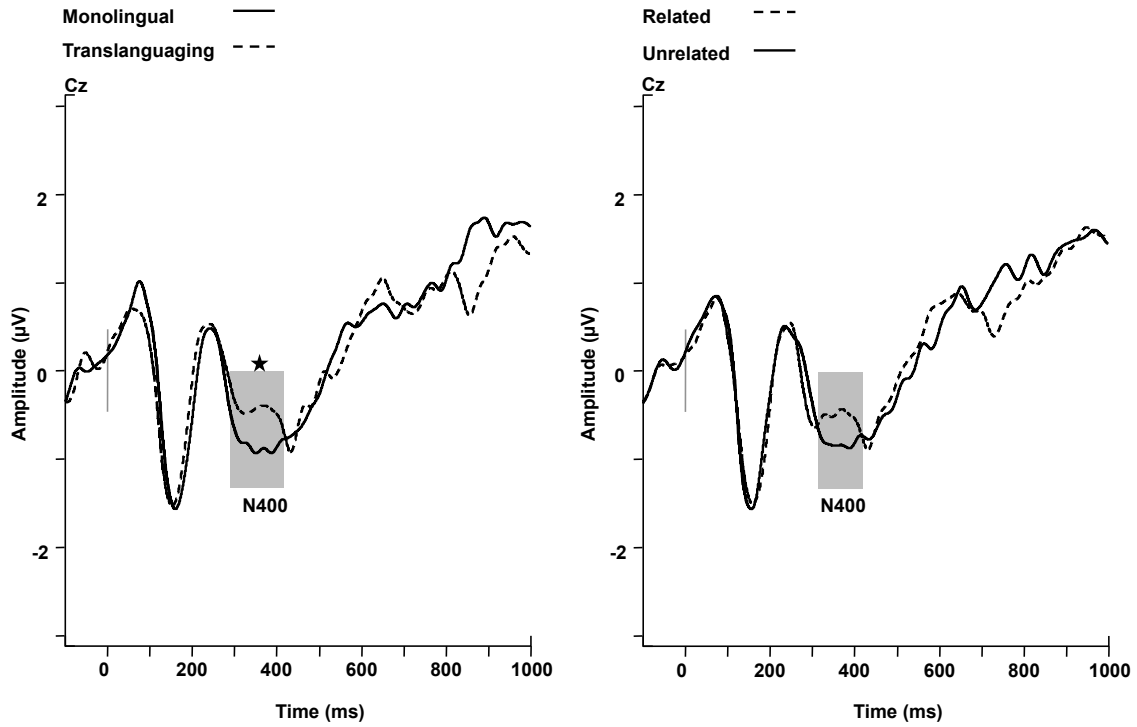

Figure 19. Grand average ERPs for related and unrelated items, as well as monolingual and translanguageing learning contexts, measured 2-4 weeks after the initial testing (Time 2). The above data shows the grand average ERPs only on one of the electrodes (Cz) as an example.

Below (Figure 20) we present the grand average ERPs on the electrodes of choice, which were used for statistical analyses (with the exception of Cz, which is enlarged and shown as an example in Figure 19).

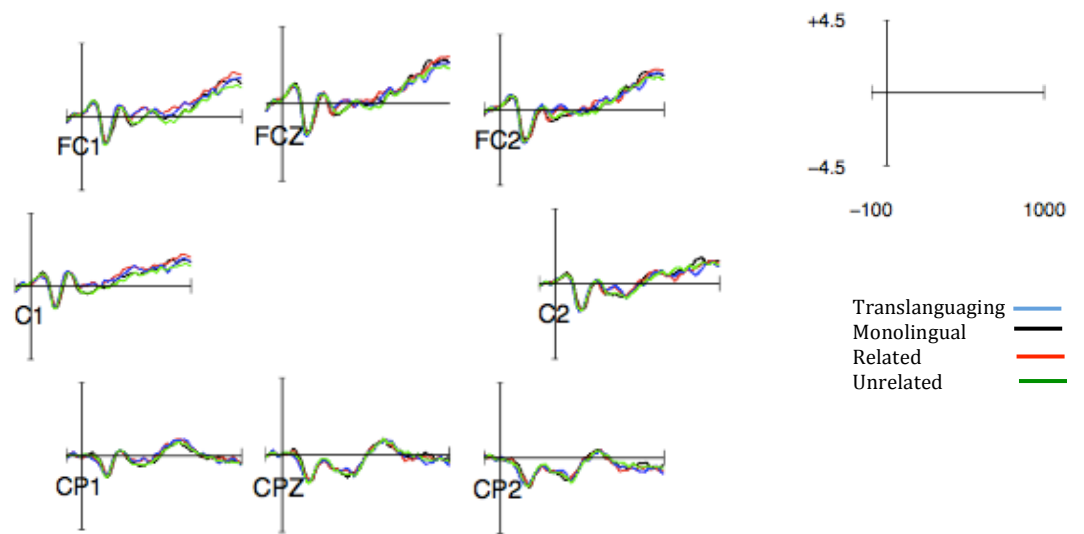

Figure 20. Grand average ERPs of the channels chosen for the statistical analyses (with the exception of Cz, which is enlarged and shown above in Figure 18 as an example).

Below (Figure 21), we present the topographical maps of the voltage amplitude for the obtained results.

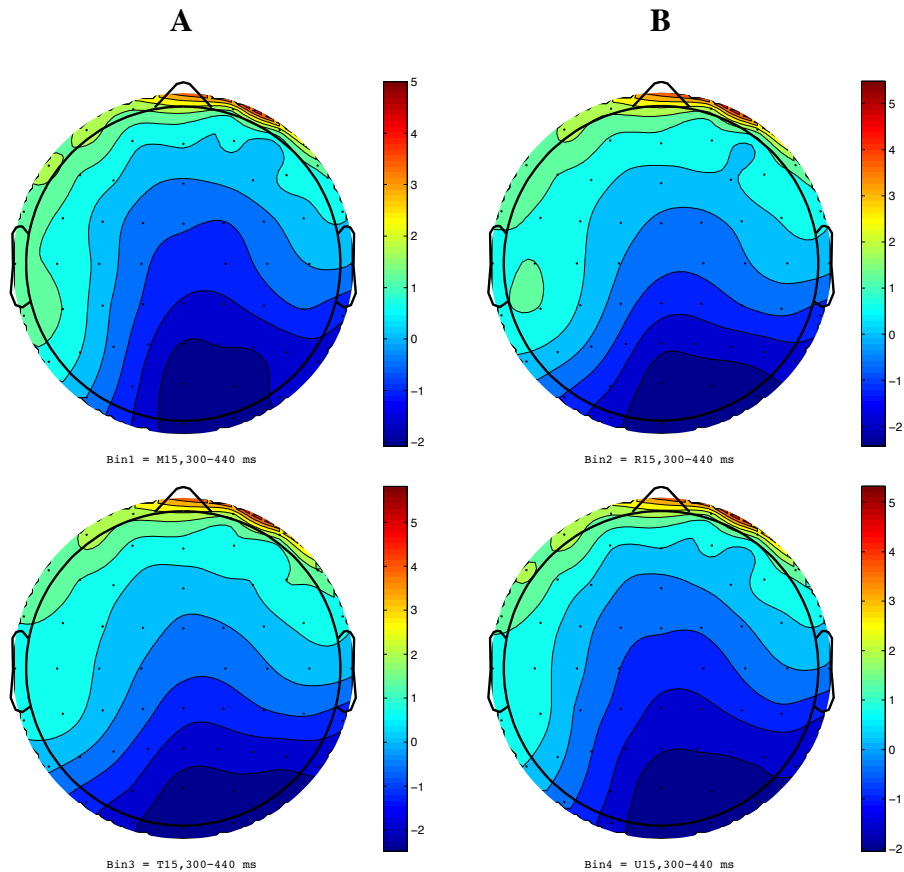

Figure 21. Topographical maps in response to monolingual (column A, top) and translinguaging (column A, bottom), as well as related (column B, top) and unrelated (column B, bottom) conditions. Time window: 300-440ms.

Discussion

The aim of the present study was to investigate the effects of acquiring new information through translinguaging, that is via a simultaneous language- and modality-switch, as opposed to learning that same information monolingually. To this end, we tested early, native-like Welsh-English bilingual adults on a novel-object learning task and manipulated the learning context. In a monolingual learning context, all the information was acquired only in English, whereas in a translinguaging learning context, information at input was in English, whereas output (i.e., participants' responses) was in

Welsh. Participants were tested at two time points: once straight after they completed the learning procedure, and then again a few weeks later without any revision. Behavioural results do show that there were some significant, although very small, differences between the groups at the initial testing. Specifically, participants took longer to learn new objects through translanguaging, rather than monolingually, and they took longer to respond to object pairs which they acquired via translanguaging. Their accuracy, however, was comparable. They also made more mistakes during phase 5, which was the explicit testing of their knowledge, in response to translanguaging objects. However, this phase was created as a ‘reality check’, to ensure that objects in both learning conditions were acquired successfully, and participants were not guessing their use, but actually knew it. By chance, they had a 25% chance of selecting the given object in phase 5. They performed well above that in both conditions, meaning that even though there was a small difference in their performance, we are confident to say that they successfully learned objects from both translanguaging and monolingual blocks. What is crucial here, however, is that all of those differences disappeared at re-testing stage, meaning that participants performed at similar levels in both conditions. Whilst those results on their own do not suggest that translanguaging has any better impact on people’s learning than monolingual instruction, they do clearly show that learning via a simultaneous language- and modality-switch is not detrimental.

However, when ERP results are analysed in light of the behavioural outcomes, the conclusions change. As expected, we obtained the N400 effect modulated by relatedness, such that related objects elicited an attenuated waveform compared to unrelated objects. This is in line with the extensive priming literature, which suggests that when targets are preceded by related, rather than unrelated primes, they are easier to process and result in a smaller N400 (see Kutas & Federmeier, 2011, for a review). Surprisingly, we have also observed a significant reduction of the N400 waveform elicited in response to pictures of the objects, which were learned through translanguaging, as opposed to the same objects acquired in a monolingual fashion. Furthermore, this N400 main effect of translanguaging was long-lasting, and was still significant at re-testing. This is especially important especially since the main effect of

relatedness has started to wear off and did not reach statistical significance at the re-testing stage.

It is important to view the behavioural and ERP results together. When analysed separately, the behavioural results suggest that initially participants struggled more in the translanguaging learning context. Whilst this is true, in light of the ERP results, the possible disadvantage is much less clear. Main effect of translanguaging within the N400 window suggests that relevant semantic representations had become selectively more accessible in participants' medium- (at Time 1) and long-term (at Time 2) memory. The reduction of the N400 to objects learned through translanguaging is interpreted in terms of semantic processing effort, which the N400 is known to index (Kutas & Hillyard, 1980), meaning that novel objects learned through translanguaging required less effort to process than those same objects learned monolingually. As the potential negative behavioural effects disappear over time, and the beneficial ERP results remain, this suggests that translanguaging should be seen as a beneficial teaching and learning strategy, despite the initial difficulties encountered by participants. Those results show that the initial difficulties do not remain for long, and do not have an impact on the long-term efficiency of semantic knowledge.

It is, perhaps, surprising that a few weeks after the initial testing, the main effect of relatedness had started to wear off and was no longer significant. It could be for a number of reasons, such as the attrition rate (nine of the initial 24 participants were not included in the retesting analysis), in which case the diminished power, rather than the wearing-off of the effect, could be the reason behind it. Additionally, as the picture-pairs seen at Time 2 testing were exactly the same (although in different order) as picture-pairs seen at Time 1 testing, it is possible that this repetition had an effect on priming. Finally, the fact that the information that they learned initially was very artificial and the objects as well as the definitions were completely made-up for the purpose of the study, therefore not allowing participants to rehearse or organise their knowledge between Time 1 and Time 2, might also have played part.

There are some methodological issues in this study that have to be addressed. Firstly, the lack of fully counterbalanced design in relation to languages used. In the monolingual blocks, all learning took place just in English, and in the translanguaging blocks all input (that is, written definitions of novel objects) was in English, whereas the output (that is, participants' verbal responses) was in Welsh. There is no doubt that the 'ideal' design would also include a fully Welsh block in the monolingual condition, and a Welsh (at input) – English (at output) block in the translanguaging condition. However, this was not possible due to time constraints and the already very demanding task. The experiment in its present format lasted around 2.5 – 3 hours per participant (sometimes even longer than that), and adding two more blocks would have made it impossible to run in one session. We tried to account for this problem by carefully selecting our group of participants, who were all early, balanced, and native-like bilinguals without a clear first and second language. Therefore, in principle, the language of learning should not have made a difference in the results, since participants were proficient in both Welsh and English to a similar extent.

The second methodological issue relates to how much of 'true' translanguaging was really involved in participants' learning, if their responses were always limited to single words only. The choice for a design of our study comes down to possible confounds that would be present if participants had the opportunity to describe the outcome of their learning to a greater extent. We have to assume that all of them would use different words, sentences of different lengths, and so on, and therefore their performance at testing would not be comparable since they would be subjected to different learning. Of course, studies that would look at the wider opportunities to translanguage are needed in the future. However, as there are literally no previous quantitative studies on translanguaging, we have decided to investigate it with single words only, in order to look at the basics of translanguaging. It is also important to emphasise that each target word that participants were using, was not present in the definitions of the novel object, meaning that participants really had to understand and remember the use of the novel object if they were to successfully name something that *relates* to it.

Conclusion

Translanguaging includes the use of full linguistic repertoires available to bilingual speakers. The key components that we argue for are language-switching combined with comprehension-to-production switch in the same context of learning new information. The present study provides the first quantitative evidence for long-lasting facilitated access to established semantic representations for information acquired via a simultaneous language and modality cross (translanguaging context) as compared to modality switch only (monolingual context). Here, we argue that learning via translanguaging encourages conceptual remapping of information across two languages, which increases understanding and produces more effective learning. This provides the first neuroscientific, quantitative evidence that such special use of language alternation in the same learning context not only does not put students at disadvantage through potential cross-contamination, but also in fact can help facilitate their new knowledge acquisition and improve their learning.

Further research need to investigate the role of the individual components of translanguaging, namely code-switching and comprehension-to-production switch, on semantic representations in the brain. Additionally, future studies have to answer the question of how translanguaging can be used in the classrooms to produce effective behavioural results, which could be generalised to everyday learning. Resolving these issues will hold further implications for models of bilingual education and bilingual language policies.

Chapter 5

Bilingual word recognition:

An ERP study with Welsh-English bilinguals.

The study described in this chapter has been submitted for publication and is currently under review.

Abstract

As it has been argued in Chapter 4, one of the two main pillars of translanguaging is the code-switching element. In the present study, the aim was to investigate this component individually, in order to establish its potential contribution to the effects found in Chapter 4. More precisely, in Chapter 4 there was an attenuated N400 in response to objects learned through translanguaging, as opposed to monolingually, and a larger N400 to unrelated, as opposed to related, objects. We hypothesised that if similar effects were found in this study, translanguaging could potentially be just a fancy word for code-switching. In order to test that, we have designed a study to investigate two issues related to bilingual word recognition. Firstly, whether semantic priming is an automatic, rather than controlled, process in early bilinguals. Specifically, we wanted to investigate whether we would obtain a larger N400 in response to unrelated, as opposed to related, stimuli, in an experimental paradigm, in which participants' attention is diverted away from the semantic content of the each individual stimuli. Secondly, whether language-switching will have an overall impact on the N400. Specifically, whether there will be a difference in the N400 between targets, which followed a language-switch and those that did not. We tested early Welsh-English bilinguals using an adaptation of a paradigm developed by Martin and colleagues (2009). Participants were presented with a stream of Welsh and English words, and were asked to press the space bar when an animal word appeared on the screen. Subjects were unaware that the words formed same-language or cross-language pairs, where semantic content was manipulated (i.e. the words formed related or unrelated pairs). Event-related brain potentials (ERPs) were measured to critical stimuli in order to investigate the changes in the N400 modulation, known to index semantic integration effort (Kutas & Hillyard, 1980). We did not observe any N400 effects modulated by relatedness, thus putting the issue of automaticity of semantic priming into question. We did, however, find an overall effect of language-block, with code-switching pairs inducing a significantly larger N400 than same-language pairs. Those results do not explain the effects found in Chapter 4, suggesting that code-switching alone cannot be used in place of translanguaging.

Introduction

This study aimed to investigate two aspects crucial to language processing in bilinguals. First, the potential cost of language-switching. Bilinguals often use more than one language in their speech by inserting words from another language. Besides the possible social or communicative advantages of it, especially in less proficient bilinguals, generally it has been accepted that such language-switching carries certain cognitive load. It has been shown that when processing stimuli in two languages, both comprehension and production are affected and are thought to be slower. This is even more prominent where the pattern of language change is unpredictable (for example, Thomas & Allport, 2000; Meuter & Allport, 1999; Grainger & Beauvillain, 1987; Soares & Grosjean, 1984). Second, we investigated the automaticity of semantic priming. One of the fundamental questions in language processing is whether the meaning of the word is automatically accessed without paying attention to stimuli ('automatic' processes) or whether awareness and attention are essential ('controlled' processes). Semantic priming is the enhanced processing of a target word preceded by a semantically related, rather than unrelated, prime word. Many have argued that it is an automatic process in skilled, literate adults and does not require them to pay any particular attention (for example, Kiefer & Brendel, 2006; Gaillard et al., 2006; Valdes et al., 2005; Fuentes et al., 1994). However, many studies have challenged that view by showing that semantic priming might not be an automatic process under certain conditions, especially when participants' attention is diverted away from the meaning of the stimuli by making them focus on other tasks (for example, Valdes et al., 2005; Mari-Beffa et al., 2000). Therefore, if this effect can be removed, this suggests that it is a 'controlled', rather than 'automatic', process.

1. On the issue of language-switching effects

There is some debate in the literature as to where the costs of language switching stem from. Perhaps the most popular view is that this cost is not to do with language *per se*, but rather is a result of individuals' cognitive control and how they can regulate their

responses under experimental conditions (Dijkstra & van Heuven, 2002; Thomas & Allport, 2000).

The Inhibitory Control (IC) model (Green, 1998) posits that task schemas are crucial in explaining switch costs. Task schemas belong to a more general task control system and are mutually inhibitory. That means that once participants use task schema 'A', it is easier for them to follow it with another task schema 'A', rather than 'B'. Another account of switch cost comes from the original Bilingual Interactive Activation (BIA) model (van Heuven et al., 1998; Grainger & Dijkstra, 1992). According to this view, switching costs are a result of a mechanism, which regulates the relative activation of lexical representations in the two languages (known as 'language nodes'). BIA model argues that language nodes have a direct impact on the relative activation level of lexical representations in the two languages (this is in contrast to later developments of this model, the BIA+, by Dijkstra & van Heuven, 2002). Therefore, the costs of language-switch are a result of a top-down inhibition from the 'wrong' language node toward the lexical representations of the target language.

Many older studies artificially exaggerated the possible influence of task schemas on language-switching effects, by assigning a different response to each language (so by responding with one button for L1, and another for L2, for example). One of the first experiments designed to address this issue was a study by Grainger & Beauvillain (1987). They found the effects of language switching in a lexical decision experiment, in which participants had to decide whether the stimulus was a real word (irrespective of the language) or not. Therefore, participants were not required to focus on the language those words were in, meaning that in theory they could ignore this information and still finish the task successfully. However, the results showed that they still processed the language to some extent. Participants were slower to respond to target words following a language switch, compared to no-switch conditions. Additionally, the effects of the switch were greater for targets in participants' second language, compared to their L1. Similar results were later obtained by Thomas & Allport (2000).

With the increasing use of neural techniques in language research, one of the first studies, which used ERPs to investigate language-switching costs, was an experiment conducted by Alvarez and colleagues (2003). Participants were presented with words from their two languages, and were asked to make a response when they saw an animal word in either language. Animal words appeared approximately in 10% of the trials and were used as fillers, meaning that they were discarded from the ERP analysis. The results showed a larger N400 waveform in response to words in participants' L2 after a language switch (i.e., L1-L2 sets) compared to L2 words not following a language switch (i.e., L2-L2 combination). No effects of language-switching were found in response to L1 targets. It is possible that participants had enough time to translate the prime word in their L2 to L1, and thus, in a way, the target in L1 was preceded by a prime also in L1. This means that the switch might not have been processed fully (as the L1 lexicon was already active from the translation of the prime word), especially that the participants in their study had low proficiency of their L2.

To overcome this possible translation strategy, Chauncey and colleagues (2008) designed a masked priming study to look at the possible effects of language-switching. It would be almost impossible for the participants to translate word primes, which appeared for 50 ms (Experiment 1) or 100 ms (Experiment 2). Additionally, all targets within one block were in the same language, so it is very likely that participants did not even consciously notice that some of the prime words were in a different language (because of such a short prime presentation duration). Such design ensured that participants could not use any translation or conscious predictive strategies. It is important to note that all words used in this study were unrelated in meaning. The results showed language-switching effects within the N250 and N400 windows, such that language-switching resulted in more negativity than same-language pairs. Specifically, they found that when targets in L1 were preceded by primes in L2, a larger negativity was found in the N400 window than when they were preceded by primes in L1. When targets in L2 were preceded by L1 primes, larger negativity was found in the N250 component, compared to when they were preceded by L2 primes. Therefore, the obtained effects largely depended on the target language: L1 targets resulted in more

prominent N400 effects, whereas L2 targets elicited earlier component (N250). The authors argued that the N250 was thought to reflect the mapping of pre-lexical representations to whole-word level representations, whereas the N400 was believed to reflect the mapping of the whole-word level representations to semantic levels. They concluded that the increased negativity in both time windows is linked to increased difficulties in processing the target word following a language-switch. According to the BIA model, the effects of language-switching are due to top-down processing modulations of activation of lexical representations as a function of language. In the above study, a prime in one language automatically activates its related language node, which in turn prevents to some extent the representations of the words in another language (van Heuven et al., 1998). Therefore, when a target word is in a different language than a prime word, this prime word activates a language node, which then inhibits the representation of the target, making it more effortful to process. When the prime and target words are in the same language, no such inhibition takes place and therefore processing is more effortless.

One potential problem with that study relates to participants' unequal proficiency levels of their two languages. Specifically, the results the authors obtained, that is the L1-L2 effects appearing in an earlier time window than the L2-L1 effects, could have been at least partly caused by the low proficiency level of participants' L2. To account for that, in a follow-up study, Chauncey and colleagues (2011) aimed to replicate this experiment with participants of higher proficiency level. In the second part of this study, their aim was also to investigate whether the results obtained in their 2008 experiment might be due to participants' subjective view of word frequency. Specifically, if their L2 proficiency was low, they could have perceived L1 words as more frequent. If the prime was in their L2, it then could have contributed to the results obtained in the L2-L1 switch. Therefore, they varied prime and target frequency in participants' L1 to investigate within-language effects of frequency switching. They hypothesised that if similar patterns were observed, it would explain the early effects obtained in their 2008 experiment. The results obtained in this study replicated the same pattern of processing, suggesting that the lower-higher L2 proficiency does not affect the overall processing.

As for the results of frequency effects, the obtained waveforms did not resemble the language-switching effects, suggesting that different mechanisms are responsible for the results. In the frequency-effect task, one component, P350, was comparably affected by language-switching and frequency-switching.

2. On the issue of automaticity of semantic priming

There is a long-standing debate in the literature concerning the automaticity of semantic priming. While it is now well established that people can access the meaning from words when paying direct attention to them, it has been shown that this process can be disrupted when their attention is directed away and towards other tasks.

Generally, it has been accepted that words are represented in memory at two main, separate levels. The lexical level is concerned with the orthographic and phonological form of the words, whereas the conceptual and semantic level is concerned with the meaning of the word. In bilingual individuals, two languages have to be accounted for and therefore such characterization has to include the links between different levels of representation across both languages.

Nowadays, there are two main models of bilingual memory: the revised hierarchical model (RHM, Kroll & Stewart, 1994; Kroll & Tokowicz, 2001; Kroll & Sunderman, 2003; Kroll & Tokowicz, 2005) and the bilingual interactive activation (BIA+) model (Dijkstra & van Heuven, 1998; Dijkstra & van Heuven, 2002). The RHM model argues for a separate, independent lexicon for each of the languages, whereas the BIA+ posits a single, integrated lexicon for the two languages.

The RHM model assumes that in the early stages of acquiring the L2, individuals use their first language (L1) to access the semantic system. Only once they reach proficiency and fluency in their second language (L2), they can use it to access semantic knowledge. Therefore, because initially learners strongly rely on their L1 to access meaning for L2, this results in an asymmetry in the form of interlanguage connections: with strong semantic connections for the L1 words, and weaker for the L2 words. This model allows, in principle, for the possibility of automatic within- and between-

language semantic priming in highly proficient bilinguals since in those individuals connections for words from both languages are equivalent. The BIA+ model assumes that during reading, semantic representations of both languages are active. It recognises that semantic representations can be activated by the lexical orthographic representations of the word. This model is nonselective and assumes simultaneous lexical search within one, integrated L1-L2 lexicon. Therefore, this model, allows for within- and between-language semantic priming in bilingual speakers, regardless of their proficiency level.

2.1 Masked priming studies in monolinguals and bilinguals

A number of monolingual masked semantic priming paradigm studies have shown that masked prime words can activate semantic representations. Those effects have been established in behavioural studies (for example, Bourassa & Besner, 1998; Bodner & Masson, 2003; Perea & Lupker, 2003; Perea & Rosa, 2002) as well as in neuroscientific investigations (for example, Grossi, 2006; Devlin et al., 2004; Gold & Rastle, 2007). Similar priming has also been obtained in eye-fixation experiments involving typical reading, with the prime word masked and presented briefly in the fovea (for example, Sereno & Rayner, 1992). Also, some bilingual masked priming studies have been done. De Groot & Nas (1991) recruited Dutch-English bilinguals and using a masked priming paradigm, found the semantic priming effects for cognate words, but not for non-cognates. One of the problems here might be participants' knowledge of English, which although proficient, was not native-like. Within a domain of masked *translation* priming, some studies found significant effects (for example, Gollan et al., 1997; Williams, 1994b), some found mixed results (for example, Finkbeiner et al., 2004), while others found no effects at all (for example, Sanchez-Casas et al., 1992). One of the obvious reasons for such discrepancies is the language background and proficiency of participants. The majority of the studies so far concentrated on bilinguals with different degrees of proficiency of their second language, and used different inclusion and exclusion language criteria. Only one masked translation priming experiment involved early, balanced bilinguals (Perea et al., 2006). In this study, Basque-Spanish

bilinguals showed a significant translation priming effect for non-cognate words in both language directions (Spanish-Basque and Basque-Spanish).

2.2 Priming experiments with visible primes

Some (Kerhofs et al., 2006; Kotz & Elston-Güttler, 2004; Silverberg & Samuel, 2004) have been able to show between-language priming in studies with visible, rather than masked, word primes. In a study investigating the effects of age of second language acquisition on the automaticity of semantic priming, Silverberg & Samuel (2004) found early automatic semantic priming for early balanced learners of the second language, but not for late learners, suggesting that semantic representations are shared for this group of bilinguals. Kotz & Elston-Güttler (2004) tested categorical and associative semantic priming (using reaction times (RTs) and the ERPs) in advanced and less proficient late German learners of English. They found that advanced speakers show similar RTs and the N400 modulation to early advanced learners and native speakers but limited categorical priming effects. The less proficient speakers failed to exhibit any RTs, but did show a modulation of the N400 in the associative priming condition. The authors have concluded that the proficiency of the second language and the type of semantic information that is presented influence how independent second language semantic processing can be. Finally, Kerhofs and colleagues (2006) have also chosen to investigate RTs and the modulation of the N400 in proficient Dutch-English bilinguals in response to interlingual homographs. Participants responded faster to homographs when they were preceded by a related, rather than unrelated, prime word (for example, when the word 'stem' (which is also Dutch for 'voice') was preceded by 'root' rather than 'fool'). In terms of RTs, participants' response was modulated by the homograph frequency, meaning they responded faster when English frequency was high or Dutch frequency was low. In terms of the ERP modulations, homographs that were following related primes induced a smaller N400 than when they were following unrelated word primes. Furthermore, the modulation of the N400 wave was also a result of the word frequency in both Dutch (L1) and English (L2).

The above studies seem to point to the existence of cross-language semantic priming in bilinguals. However, it is not possible to overlook the fact that none of those studies recruited participants with native-like knowledge of their two languages.

3. On the masked *versus* visible primes – does it really matter?

The design of the study is important. Kouider and colleagues (2007) have emphasised that behavioural as well as neuroimaging evidence shows that different processes in the brain are involved when processing masked, as opposed to visible prime words.

Therefore, it is often difficult to reliably compare the results of different studies, if some of them used masked, while others used visible primes. Proponents of using masked priming paradigms argue that this allows for a true measure of any early and automatic, rather than strategic, effects. This is because participants are very unlikely to be able to process the prime word and its meaning under masked conditions. However, even though in masked priming paradigms the prime word is presented very briefly (usually for around 30-60 ms), it has been argued that participants might still be able to start processing the meaning of word primes unconsciously (Naccache et al., 2005). It has been suggested that semantic information might be activated as soon as the prime word is presented, and hence semantic information from primes can facilitate the lexical access of targets (Fischler & Goodman, 1978; Perea & Gotor, 1997).

4. On the issue of language criteria in bilingual studies

The question regarding how bilinguals comprehend language, especially with regards to the automaticity of semantic priming, remains open. One of the main concerns with regards to studies investigating bilingual word processing is the type of bilinguals used. The vast majority of studies recruited bilinguals with different definitions of 'proficiency', and almost none of them used early, balanced and highly proficient individuals (that is those, that have been growing up with two languages in their natural environment). It is important to point out that even the most proficient bilingual might have different processing strategies to those who have grown up with two languages in their natural environment. It has been suggested that in those two situations, the lexical

development of L1 and L2 might be very different (for example, Bosch et al., 2000; Brysbaert, 2003).

5. On the issue of automatic semantic priming in early, native-like bilinguals

To my knowledge, so far there have been only three studies, which investigated automaticity of semantic priming in early, balanced bilinguals who grew up with their two languages and have native-like knowledge of both of them. Those studies included Basque-Spanish (Perea et al., 2008), Catalan-Spanish (Guasch et al., 2011), and Welsh-English (Martin et al., 2009) speakers.

Perea et al. (2008) tested within- and between-language priming using noncognate words in a masked priming paradigm in order to establish whether semantic representations are shared across languages in early, balanced Basque-Spanish bilinguals. They have found that participants showed early and automatic cross-language semantic priming. They also reported that the magnitude of the effect was comparable within- and across languages. Additionally, they have replicated those findings with late but highly proficient bilinguals. They concluded that highly fluent, early bilinguals develop early and automatic cross-language representations at the semantic level, thus providing support for both the hierarchical and the BIA+ models.

Guasch et al. (2011) investigated whether meaning of the words can be accessed from the two languages in Catalan-Spanish bilinguals. They have investigated the processing of word-pairs with different degrees of semantic relationships (going from no relationships at all, through close and very close relationships, to direct translations). The participants were presented with a prime word (for 250 ms), followed by a target (for 1000 ms) and asked to indicate with a button press whether it is a real word or not. They found that the degree of semantic overlap between words in different languages modulates the effects of priming, with the greatest priming obtained in the translation condition, followed by the very close and close conditions. The results did not depend on the language of the prime, suggesting that the magnitude of priming in highly proficient, native-like bilinguals is the same in both language directions. The authors

concluded that there is a cross-language activation of semantic knowledge, which provides the support for the hypothesis that these types of bilinguals have direct access to word meaning in their two languages.

The study of the main interest here is the experiment conducted by Martin and colleagues (2009), which investigated the automaticity of cross-language priming in Welsh-English bilinguals. This is the only study, of the 3 described here, which has used ERPs alongside the behavioural measures. In their study, participants were asked to only pay attention to one type of stimuli (either English or Welsh) and told to disregard the stimuli in the other language. Their question was whether in early, highly balanced bilinguals, both languages are active at all times, or whether individuals can control the processing in one language but not the other. They presented participants with a stream of words, appearing one by one, and instructed them to decide whether the target word has more or less than 5 letters. Participants were not explicitly told that the stream of words is arranged such that they create language pairs where semantic relatedness and the language of the prime were manipulated. Using ERPs, they have found significant semantic priming effects in the N400 range irrespective of the 'active' language and independent of their performance in the letter-counting task. The authors concluded that early, balanced bilinguals automatically access the meaning of the word in their two languages, even when they are told to ignore one of them.

6. The present study

The goal of the present study was to investigate whether semantic priming is an automatic process in early, native-like bilinguals, when their attention is oriented away from the semantic content of the stimuli. We have taken advantage of a paradigm developed by Martin et al. (2009), and adapted it to fit the needs of our study. The authors of that study have concluded that early, native-like bilinguals automatically process the words in a language they were told to ignore. However, it is not possible to rule out the fact that they processed all of the words, since they must have somehow categorised the words as belonging to one language or another. Here, we have aimed to minimise the chance of overt processing of the words, by asking participants to spot the

animal word (which was a filler only) within a stream of Welsh and English words and press a space bar when they did so. They were not asked to perform any behavioural response to the other words. This was done to minimise the probability of overt semantic appraisal of the presented words. We hypothesised that if participants showed a within- or between-language semantic priming effect when their attention was deliberately diverted to filler words, that would provide further support for the automaticity of semantic priming in early, balanced bilinguals. As in the study by Martin et al. (2009), the participants in our study were bilinguals from North Wales – a region where a large proportion of population is highly fluent (since early childhood) in the two official languages: Welsh and English.

Methods

Participants

18 (5 males, average age 24.15 years old) highly proficient and fully balanced Welsh-English bilinguals participated in the study. Each participant filled out a language questionnaire on his or her background. Only participants who reported to be early (before starting school), balanced Welsh-English bilinguals (i.e., those who had every day exposure to both languages and still report to be using both languages daily in their professional/academic as well as personal lives) were included in the study. None of the participants reported to have any known reading difficulties and all of them had normal, or corrected to normal, vision. All participants gave written consent to take part in this study, previously approved by the ethics committee at Bangor University. Participants were given 5 course credits or compensated £15 for their participation.

Due to the balanced and frequent exposure at home, school and the general environment to both Welsh and English from birth, which characterised our participants, it is impossible to determine which language is ‘dominant’ or ‘native’, and which is the ‘second language’. Therefore, we have decided not to refer to our participants’ languages as L1 and L2, and instead refer to Welsh and English (see Perea et al., 2008;

and Guasch et al., 2011, for a similar decision in the case of their Basque-Spanish and Catalan-Spanish bilinguals, respectively).

Materials and design

A set of 112 highly familiar English nouns was created through the MRC psycholinguistic database (Coltheart, 1981). Additionally, a Welsh-native speaker translated all of the words to Welsh. All nouns were then split into two groups, with 56 words that acted as primes, and 56 that acted as targets. The English stimuli in both groups were matched for concreteness, familiarity, and frequency of use. Welsh and English words were also matched for average lexical frequency (using the CEG database, Ellis et al., 2001) and length.

Eight pseudo-randomised blocks of 56 pairs in each block were created, with each word being presented 4 times in the experiment but never more than once in a given block. Therefore, each participant was presented with four semantically related and four semantically unrelated blocks, which consisted of 56 English-English word pairs, 56 Welsh-Welsh word pairs, 56 English-Welsh word pairs, and 56 Welsh-English word pairs. The order of blocks was counterbalanced across participants. Additionally, 14 animal words (7 in English and 7 in Welsh) were created and used as fillers in each block of the experiment. The animal words were to ensure that participants attended to and analysed all the words presented in the experiment.

Participants were presented with a stream of Welsh and English words on a computer screen, one at a time, and were asked to press the space bar on a keyboard when they saw an animal word in either language. Please see figure 22 (below) for the experimental procedure. All words were presented for the total duration of 350ms, with a variable inter-stimulus interval (ISI) of 450-750ms, in steps of 50ms.

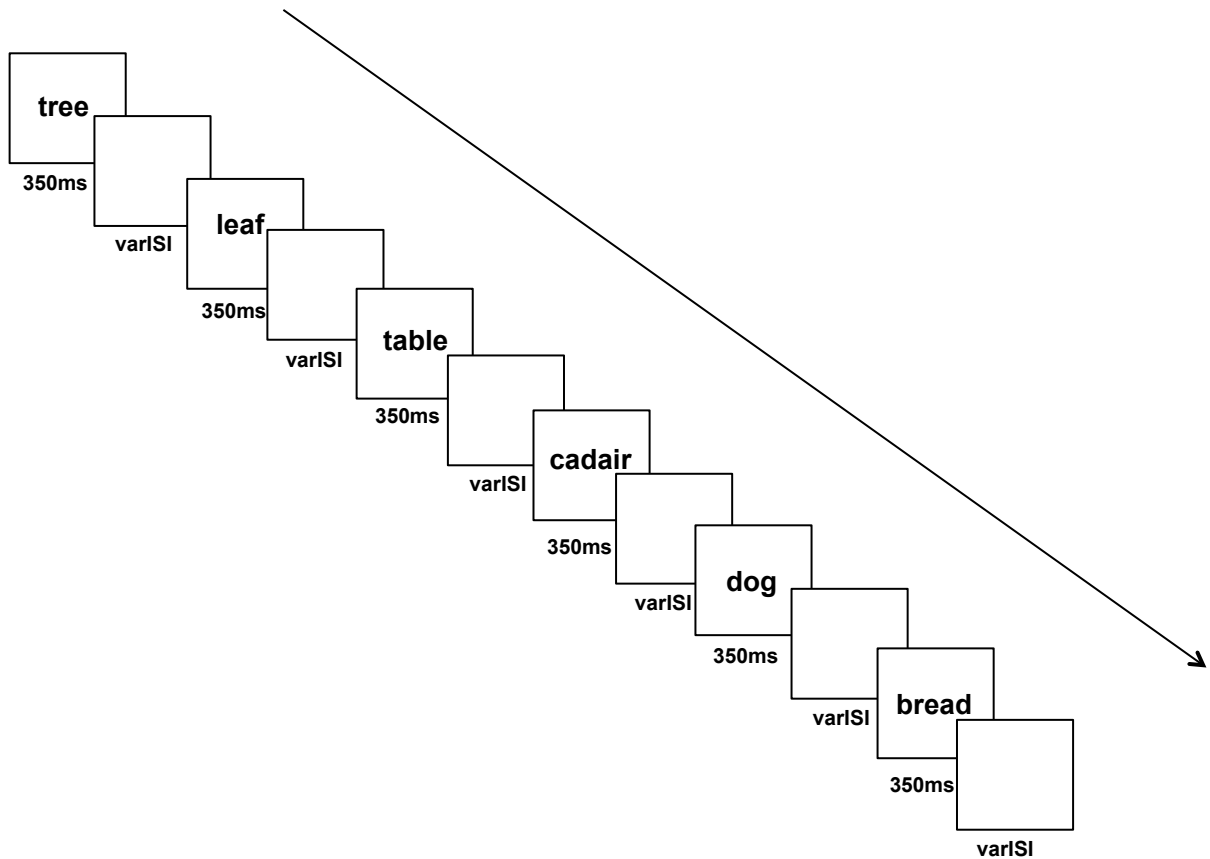

Figure 22. An example of the experimental procedure. Participants were asked to press the space bar when they saw an animal word in either language (Welsh or English). The variable inter-stimulus interval (varISI) was set between 450 and 750ms, in steps of 50ms. *Cadair* means *chair* in Welsh.

Participants were not explicitly told that words within each stream are arranged in a pseudo-randomized fashion, such that they form word-pairs that can be either related (e.g. *girl* and *boy*) or unrelated (e.g. *leaf* and *mug*) in meaning, and can be either in the same (i.e. English-English or Welsh-Welsh) or in different (i.e. English-Welsh or Welsh-English) language. Please see Table 9 (below) for examples of word-pair manipulations. Therefore, the study fitted into a 2x2 ANOVA, with language (same, different) and relatedness (related, unrelated) as factors.

Condition	Prime language	Target language	Semantic relatedness	Example
1	English	English	+	girl – boy
2	English	English	-	leaf – mug
3	Welsh	Welsh	+	oergell (<i>fridge</i>) – cegin (<i>kitchen</i>)
4	Welsh	Welsh	-	trwyn (<i>nose</i>) – brenin (<i>king</i>)
5	English	Welsh	+	bread – menyn (<i>butter</i>)
6	English	Welsh	-	eyes – cylllell (<i>knife</i>)
7	Welsh	English	+	ffisig (<i>medicine</i>) - doctor
8	Welsh	English	-	llaw (<i>hand</i>) - station

Table 9. Examples of the stimuli in each condition. In the *semantic relatedness* column, “+” indicates the presence of semantic relatedness, whereas “-“ indicates that the two words (prime and target) were semantically unrelated.

Electrophysiological recording and data analysis

EEG data was continuously recorded using Neuroscan 4.4 (Neuro-Scan 4.4, Charlotte, NC) in reference to a Cz electrode, at a rate of 1 kHz, from 64 Ag/AgCl electrodes arranged according to the extended 10-20 system (Jasper, 1958). One additional electrode was attached below the right eye and another additional one on the side of the right eye, in order to monitor for participants’ eye-blinks and horizontal eye movements. EEG signals were filtered offline with a 30Hz low pass zero phase shift digital filter. Eye-blink artefacts were mathematically corrected using an algorithm provided in NeuroScan 4.4, which is based on the Gratton et al.’s (1983) method. Continuous EEG data was then used to create epochs ranging from -100 before the presentation of the target stimulus, to 1000ms after its presentation. ERPs were created by averaging the epochs, time locked to target stimulus presentation. Individual averages were re-referenced to the global field power produced over the entire scalp. Impedances were kept below 5KOhm.

Please note, that no full-scalp analyses were conducted. This is because the modulation of the ERP components was predicted to be strongest in the region of interest and thus the statistical analyses of the mean amplitude of the N400 were performed in the electrodes previously determined (predictive approach), based on the extensive N400 literature available to date (see Kutas & Federmeier, 2011, for a review). Mean amplitudes were then used in repeated measures 2 x 2 ANOVA, with relatedness (related, unrelated) and language (same, different) as factors.

The N400 effect was maximal at central sites, and mean ERP amplitudes were measured in the 300-420 ms window, on 9 electrodes: CP1, CP2, CPz, C1, C2, Cz, FC1, FC2, FCz. ERPs were measured to target words. Fillers (animal words) were discarded from the ERP analysis.

Results

1. Behavioural results

Since the experiment did not require an overt task on the critical trials, no behavioural data for word-pairs is provided. In terms of pressing the space bar when participants spotted an animal within the stream of words, their accuracy was high and reached just over 86%. As all the words were presented for only 350 ms, the participants had up to 2 seconds to press the space bar after seeing an animal word. If they did it any later than that, this response would not be registered.

2. ERP results

As expected, in line with the previous literature, the maximal N400 effect was obtained on the central electrodes. The following electrodes were chosen for the analysis: CP1, CP2, CPz, P1, P2, Pz, FC1, FC2 and FCz. All of them were used when performing statistical analyses. Figures 19 and 21 (below) show the data only from one of those electrodes (here, Cz) as an example to illustrate the obtained results.

2.1 Automatic semantic priming effects

Figure 23, below, represents the grand average waveforms elicited in response to related and unrelated word pairs, suggesting there was no N400 effect modulated by relatedness. That is, that semantically related word-pairs did not result in an attenuated N400 compared to unrelated pairs. This is shown to be the case for same-language and code-switching pairs. Those results were confirmed by further statistical analyses. A 2 x 2 ANOVA showed that there was no main effect of relatedness, [$F(1,17) = 0.103$, $p = 0.752$].

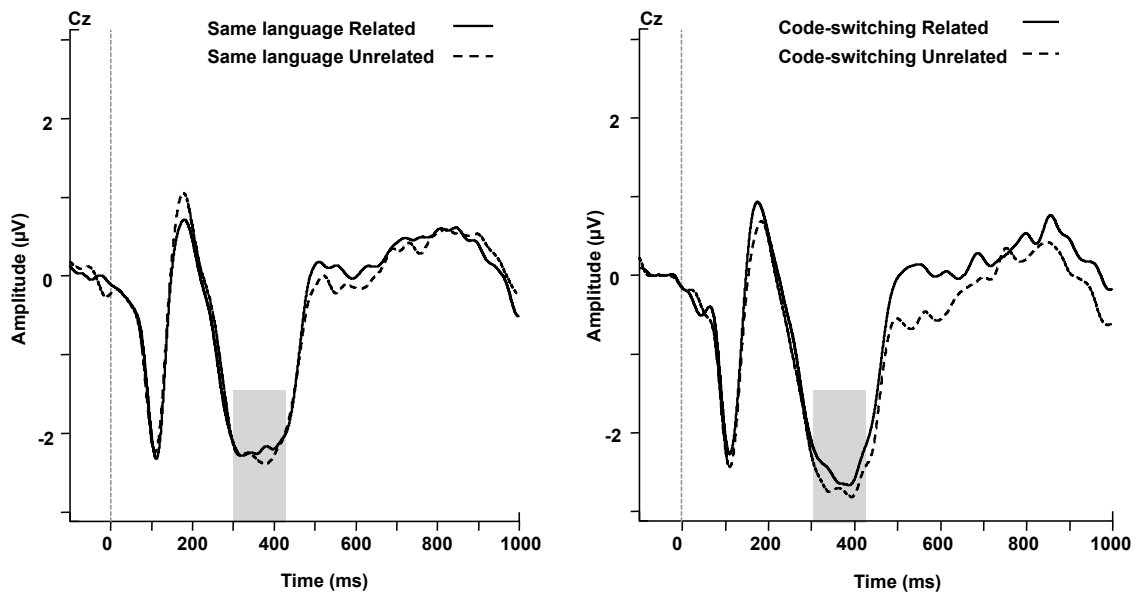

Figure 23. Grand average ERP graphs representing the waveforms elicited in response to related and unrelated word-pairs. No significant semantic priming effects were found. The above data shows the grand average ERPs only on one of the electrodes (Cz) as an example.

Below (Figure 24) we present topographical maps of the voltage amplitudes.

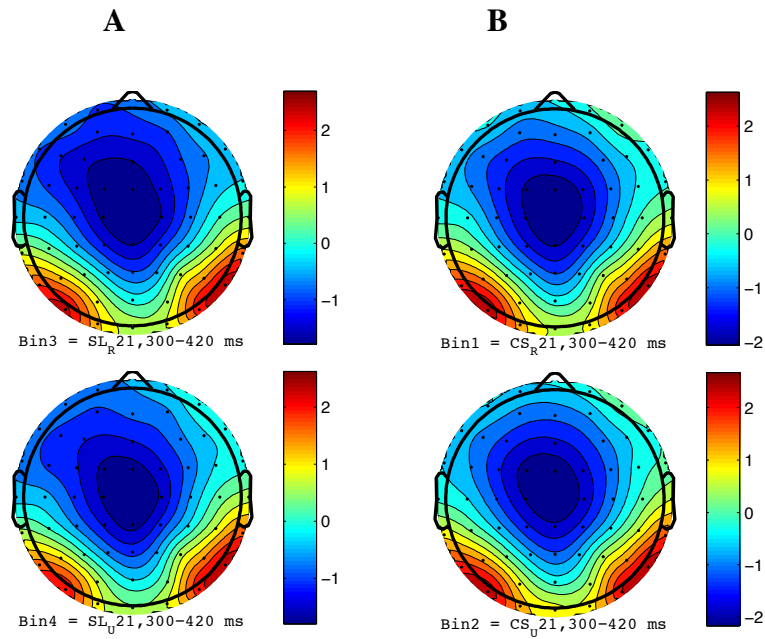

Figure 24. Topographical maps of the voltage amplitudes. Column A shows data for the same-language related (top) and unrelated (bottom) word-pairs. Column B shows data for the code-switching related (top) and unrelated (bottom) word-pairs. Time window: 300-420ms.

2.2 Language-switching effects

Figure 25, below, represents the grand average waveforms elicited in response to language-switching, indicating that language-switching word-pairs induced a significantly larger N400 than same-language pairs, irrespective of relatedness. It was also confirmed in a 2 x 2 ANOVA, which showed a significant main effect of language switch on the N400 mean amplitude, [$F(1,17) = 7.112, p = 0.017$], such that the N400 in mixed language word-pairs (Welsh-English and English-Welsh) was more negative than in the same-language (Welsh-Welsh and English-English) pairs.

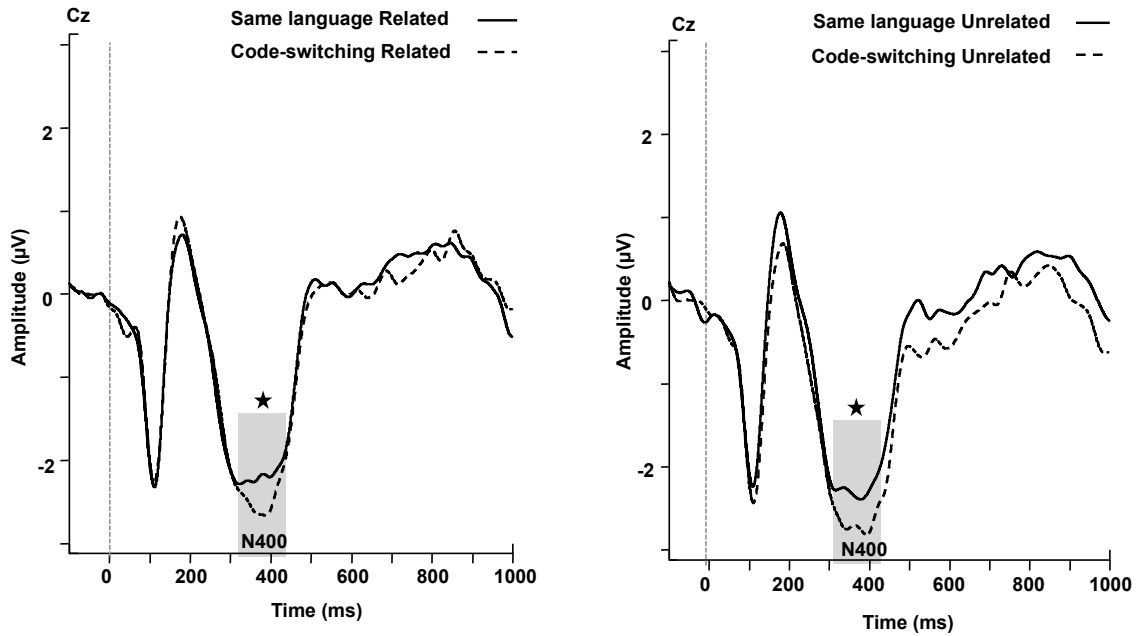

Figure 25. Grand average ERP graphs representing a larger N400 following a language-switch, compared to same-language word pairs. The above data shows the grand average ERPs only on one of the electrodes (Cz) as an example.

No language x relatedness interaction was observed, [$F(1,17) = 0.015, p = 0.905$].

Below (Figure 26), we present grand average ERPs on the channels selected for the statistical analyses (with the exception of Cz, which is enlarged and shown above in Figure 25 as an example).

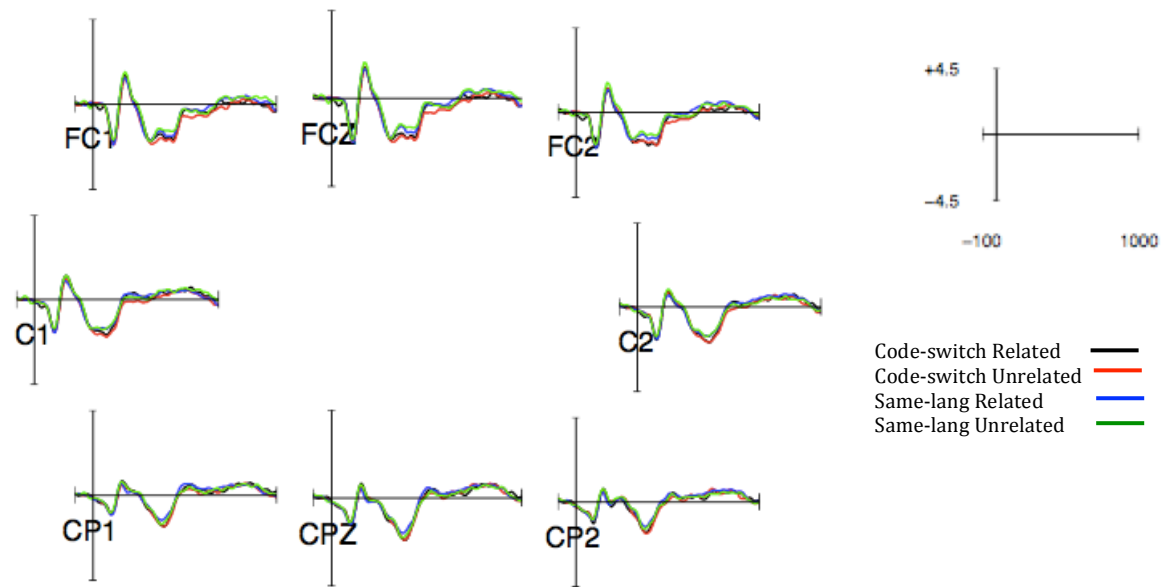

Figure 26. Grand average ERPs of the electrodes that were chosen for statistical analyses (with the exception of the Cz electrode, which is enlarged and shown above in Figures 20 and 21 as an example).

Below (Figure 27) we present topographical maps of the voltage amplitudes obtained in the experimental conditions.

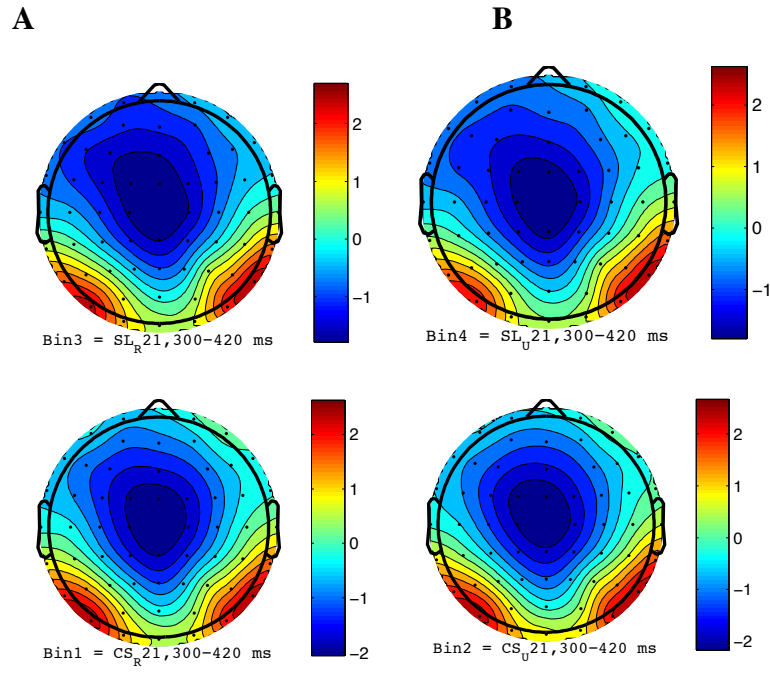

Figure 27. Topographical maps of the voltage amplitudes. Column A shows data for the related same-language (top) and related code-switching (bottom) word-pairs. Column B shows for the unrelated same-language (top) and unrelated code-switching (bottom) word-pairs. Time window: 300-420ms.

Discussion

The aim of the present study was to investigate two main issues concerning bilingual language processing, namely the automaticity of semantic priming, and the impact of language-switching on semantic integration as indexed by the N400 component.

In order to do that, we adapted a paradigm developed by Martin et al. (2009), which had the potential to investigate those two aspects of interest.

1. The automaticity of semantic priming

Firstly, let's examine the aspects of the potential automaticity of semantic priming.

Here, the goal was to test whether semantic priming is an automatic process in early, native-like bilinguals, and occurs when participants' attention is diverted away from the critical stimuli and their semantic content. In order to test that, participants were asked to focus on recognising an animal word, which in fact was a filler word rather than one

of the critical stimuli. We found no effect of the semantic content of the stimuli, either within or across languages. Specifically, if semantic processing were an automatic process, we would have expected to see related items resulting in a more attenuated N400, compared to the unrelated items. Instead, what we found was that the items, which in fact were ‘related’, were seen as ‘unrelated’, to the same extent as the real ‘unrelated’ word pairs. This is evident in essentially the same amplitude as measured by the ERPs in response to those two types of stimuli. This is in contrast to what we expected to find based on Martin et al.’s (2009) results. In their study, the authors concluded that even when participants are told to ignore the stimuli in one language, it remains semantically active within the first 400 ms after the onset of the target word. However, it is important to emphasise that paying attention to words from only one language assumes that participants can successfully categorise the words as belonging to two different language sets. In order to do that, they need to somehow register them, regardless of which language they are in. Such classification could be done very early on, at the pre-lexical stage of word processing, or slightly later, at lexical and semantic stages, at which the meaning of the word, rather than its pure orthographic form, is accessed. The results obtained by Martin and colleagues (2009) seem to suggest that this language-classification was done at a later stage because the EEG analysis showed semantic priming for targets in both languages, and not just the one they were performing the task in. However, it is important to point out that a similar issue might be problematic in the present study. Even though the participants were only asked to act and provide a response to certain (animal) words (which was done on purpose so that there would be no overt response to the critical stimuli), it cannot be ruled out that they must have processed all of the words, nonetheless. This is because in order to successfully categorise a word as ‘animal’, one must be able to also categorise all the other ones as ‘not animal’, which suggests at least some level of processing. However, if that was the case, we would expect to see the modulation of the N400 by the relatedness of the word-pairs, as it happened in study by Martin and colleagues (2009). The fact that we did not observe such effect, which is in a sharp contrast to Martin et al.’s (2009) study could be explained by the timing of the processing of the stimuli. Martin et al.’s (2009) results suggest that the classification of the stimuli in their study

by the participants was done at a later, lexico-semantic rather than the orthographic, stage. Our results, however, seem to suggest that the participants' categorisation of the stimuli was performed at any earlier stage, where purely the orthographic form of the word was accessed. This difference in the results could be due to a different study design, as well as essentially a very different task that the participants were asked to perform. Additionally, the timings used in Martin et al.'s (2009) study were very different, with stimulus onset asynchronies of 1000 ms, which puts into question the true automaticity of semantic priming. In order to address this question, different (shorter) timings should be used, in order to minimise the probability that participants are performing some overt, conscious evaluations of the stimuli and their semantic content. Therefore, it is possible that in Martin et al.'s (2009) study, participants registered the words in their two languages in order to successfully classify them as 'need to pay attention to' and 'can ignore', and then perform the overt behavioural task only on certain words, belonging to the language of interest.

Therefore, to address those issues, in the present study, we have taken advantage of the overall aim of their design, in that the words were appearing one by one on the screen and participants were not explicitly told that they are arranged in pairs. However, we have decided to control for those two aspects by a) diverting participants' attention away from the stimuli of interest, in any language, and instead focusing on detecting animal words (fillers). This meant that the participants only had to provide a response to certain words, unlike to all of the stimuli as it was done in Martin et al.'s (2009) study, and; b) by changing the timings of the stimuli presentation, such that the presentation of target words was much shorter. Those two amendments together helped to ensure that the participants are not overtly analysing the meaning of any stimuli of interest.

It is difficult to put our results in the context of the two models described in the introduction, since both of them argue for between-language semantic priming in proficient bilinguals. Our results show a complete lack of the relatedness effect, which questions the automaticity of semantic priming. Those results might be due to selective attention, which is the ability to pay attention to one aspect of the environment while

ignoring the others (Luck et al., 2000). It is possible then, that our participants were concentrating on detecting animal words (and did so very successfully) so hard, that they ignored all other aspects.

It is important to mention here that when trying to assess automatic semantic priming across-languages in bilinguals, one is immediately faced with a more general problem: there is still a disagreement over whether such effects even exist in monolingual studies (Perea et al., 2008). If, indeed, such effects do not exist within-language, it would be highly surprising to find them between-languages. We are not making definite claims whether such effects exist or not, as they have been found in a number of studies. We have, however, failed to detect them in our study, and our results certainly add new information to the ongoing debate.

2. The effects of language-switching

Secondly, let's examine the effects of language-switching. This study was also similar to those by Chauncey and colleagues (2008; 2011), in that participants were asked to spot animal words that did not belong to a set of critical stimuli. However, here we used a paradigm with visible primes, as opposed to masked-priming in Chauncey et al.'s studies. We also manipulated the relatedness within the critical stimuli, whereas Chauncey et al. used only unrelated words.

Our results show a main effect of language-switching within the N400 window, such that target words following primes in the same language resulted in an attenuated N400 compared to primes in a different language. This is interpreted as mirroring greater effort in integrating information across the lexical and semantic levels. This is in line with the results of other studies, which found a larger N400 following a language-switch (for example, Alvarez et al., 2003; Chauncey et al., 2008; Chauncey et al., 2011). However, it is important to emphasise that in those other studies, the effect was a function of the target language and differed whether target words were in participants' L1 or L2. Here, we did not divide our analysis into such groups, because the participants in our study were early, highly proficient, native-like bilinguals, and it would be impossible to determine which language was their first, and which was their

second. Therefore, we measured the effects of language-switch irrespective of the language of the prime and target.

It is possible that the obtained results of language-switching are to do with the task schemas, as predicted by the IC model (Green, 1998). As mentioned in the introduction, task schemas, which are a part of the task control mechanisms, have an important role when explaining language switch costs. They are mutually inhibitory in nature, which means that after applying task schema A, it requires less effort to follow it up with another task schema A, rather than incorporate and process a new task schema. Here, switching languages can be compared with switching tasks, so after a language-switch the cost of processing increases due to the control mechanism prepared to activate the ‘incorrect’ language. As this study used visible, rather than masked primes, and all the words were presented for exactly the same duration, it seems plausible that task schemas are responsible for the more effortful processing following a language switch. However, it is also possible to interpret the possible effects within the BIA framework (van Heuven et al., 1998; Grainger & Dijkstra, 1992). Presentation of the prime word activates the corresponding language node, which in turn inhibits the representations of words in the ‘irrelevant’ language. This means, that when primes and targets are in different languages, the target’s representation gets inhibited by the language node activated by the prime word, resulting in more effortful processing. If the prime and target are in the same language, no such inhibition takes place, resulting in easier processing of the target.

3. Handling of the data

For the analysis, Welsh-English and English-Welsh blocks were combined together to create a mixed-language condition, and Welsh-Welsh and English-English blocks were combined together to create same-language condition. This is because it has been established that in early, balanced bilinguals, such as those in the present study, the magnitude of the effect is similar irrespective of the language of the prime (for example, Perea et al., 2006; Perea et al., 2008; Guasch et al., 2011).

Conclusion

The present study provides two important elements in the discussion of how bilingual individuals process words. Firstly, it puts into question the automaticity of semantic priming. We did not observe any differences within the N400 range modulated by relatedness, neither within nor across languages. In fact, the amplitude of the N400 negativity was remarkably similar in related and unrelated word-pairs. This suggests that when participants' attention is diverted from all the critical stimuli, semantic information is not automatically accessed. As mentioned above, it could be that they are processing the words at an earlier, orthographic rather than semantic stage, which could be the reason for the lack of . Secondly, we found a main effect of language condition, such that same-language word pairs showed an attenuated N400 compared to word-pairs, which included a language switch (that is, the prime word was in a language different to that of the target word). This seems to suggest that even though the participants did not automatically access the semantic information from the words (they did not process the meaning of them and therefore their relatedness), they did automatically notice the language change within the word-pairs. It is possible that participants automatically access only the pre-lexical and lexical information about the words, but not their semantic information.

To the best of our knowledge, this is the first study, which combined the investigation of both the automaticity of semantic priming and the effects of language-switching in early, native-like bilinguals. Clearly, more research is necessary in order to validate and further explain the obtained effects. What is clear, however, from the point of view of translanguaging, is that none of the effects obtained in this study explain what was found in Chapter 4. In fact, the effects of language-switching found in this study are in exactly the opposite direction to what was found in translanguaging. Therefore, translanguaging is not just a 'fancy' word for code-switching and cannot be reduced to simple language manipulations.

Chapter 6

The electrophysiology of comprehension and production of words and pictures in Basque-Spanish bilinguals.

An ERP investigation.

This study has been conducted as part of the Santander Special Mobility Grant, awarded to Anna M. Beres, in collaboration with **Dr Adam Zawiszewski** and **Prof Itziar Laka**, during a study visit at the University of the Basque Country, Spain.

Abstract

As it has been argued in Chapter 4, the two main pillars of translanguaging are language-switching and switching from comprehension to production (modality-switching). This chapter aimed at investigating modality-switching individually in order to establish its potential impact on the overall effects obtained in Chapter 4. The present study explored the electrophysiology of picture and word naming, with the aim to understand the effects that switching from comprehension to production have on semantics and the N400. Two blocks of word-word and another two of word-picture pairs were presented. In half of them, participants were asked to decide whether the pairs are related in meaning or not, by pressing the corresponding key on a keyboard. In the other half, they were asked to name out loud the target stimuli of each pair (in one block, they were naming words, whereas in the other, they were naming pictures), before making the relatedness judgment with a button press. Our interest here was the potential impact of production on the N400, since the aim was to establish the individual contribution of modality-cross to the overall effect obtained in Chapter 4. Word-word and word-picture blocks were analysed separately. Apart from modulations of the N400, we also found early effects of comprehension and production, with the effects starting to diverge as early as 80 ms after the onset of a target stimulus. The data offers evidence that the ERP waveforms are modulated by participants' intention to speak.

Introduction

1. How people produce words

In terms of producing single words, there is an agreement across the current models that production of words involves a number of steps, each creating a specific type of representation. Information spreads between those representations through the spreading of activation.

The first step involves establishing what kind of notion the speaker wants to express, such as which person or object they wish to name and how (such as saying *the baby*, *the boy*, or *he*). This decision depends on many factors, such as which term the listener might be familiar with or whether the speaker knows the person well, and so on. Following that, as Levelt, Roelofs, and Meyer (1999) argue, there is a lemma selection stage, which is followed by choosing the correct corresponding phonological form. A number of different lemmas might be active at the same time (for example, when we have not yet chosen whether we want to say *cat* or *kitten*), and therefore selecting a lemma is seen as a competitive process. When the activation of a particular lemma is very high and it exceeds the summed activation of the competing lemmas, it is selected (Clifton et al., 2013). The next step is for the speaker to generate a correct word form. Some researchers argue that there is a clear distinction between those stages (lemma and the word-form level) and the evidence for that comes from ‘tip of the tongue’ situations, in which people feel they know what they want to say and can retrieve some information about the word but cannot produce it fully (for example, Vigliocco et al., 1997). The fact that they can often retrieve some partial lexical information shows that the lemma and the word-form are accessed separately. At the word-form level, people first have to retrieve one or more morphemes (depending on how many morphemes the word they are trying to retrieve has). Levelt and colleagues (1999) argue that people build the morphological representations by accessing and combining the individual morphemes. Following that, they need to create the phonological form of the word out of individual phonological fragments, rather than the whole phonological unit at once. Levelt and colleagues (1999) state that those phonological sections are retrieved in a

parallel fashion. The retrieved string of those sections is then divided into syllables, and the stress of the word is allocated. This process moves along from the beginning towards the end of the word in a progressive manner. Phonetic encoding is the final stage in word-form representation, in which the articulatory gestures are identified (Clifton et al., 2013).

Those steps in single-word production, that is the structural (with the distinction between the conceptual, syntactic, individual morphemes, phonology and articulatory representations) and order of representations (conceptual, followed by syntactic, morphological and articulatory encoding) assumptions, are generally agreed on amongst the researchers in the field. The evidence obtained from reaction time studies (for example, Roelofs, 1997), error analysis of healthy and clinical individuals (for example, Dell et al., 1997) and neuroimaging research (for example, Indefrey & Levelt, 2004) clearly supports this overall structure of word production.

However, there are some controversies with regards to how the information moves from one level to another. Levelt and colleagues (1999) propose that it happens in a bi-directional way initially, but is sequential from the stage of the lemma selection, whereas others argue that this flow is continuous and that even when the person does not wish to name an object, its name can be still activated (Roelofs, 2008). If the information was moving along only in sequential fashion, this unintentional activation should not occur.

Another debate centres on the time it takes to select target lemma. Levelt et al. (1999) argue that it depends on the activation of other, competing lemmas, whereas others have argued that the two are independent. On the one hand, there is evidence from picture-word interfering paradigm, in which people take longer to name the picture if it was presented with a semantically related, rather than unrelated, word. This longer naming time is thought to stem from relating lemmas competing more strongly for selection than the unrelated ones (for example, Schriefers et al., 1990; Rahman & Melinger, 2009). On the other hand, the opponents of this view argue that the lemma selection

stage is not competitive and this interference happens at the later stage, when people select the response (for example, Mahon et al., 2007; Mahon & Caramazza, 2009).

Speaking and listening to other people talk have traditionally been thought of as separate activities, and perhaps that is why the vast majority of psycholinguistic studies concentrated on exploring those aspects in isolation. However, more recently such approach has been questioned. Pickering and Garrod (2007) argue that production cannot be seen in isolation, as it is tightly linked with comprehension. They hold the view that comprehension has to involve the production system to some extent, because people tend to influence one another during conversations and the words that one person produces are bound to have an effect on how the other person understands it and then responds to it (Garrod & Pickering, 2004). Indeed, in real life, people generally engage in conversations, thus in aspects of both comprehension and production, rather than just one of those. Therefore, it is not unreasonable to hypothesise that some concepts are shared between language comprehension and language production. As Clifton et al. (2013) point out, the same representations are probably accessed when we read, hear and produce words. Therefore, if we assume that those different activities all involve shared concepts, it is logical to assume that the processes that lead to accessing those concepts are also similar. Pickering and Garrod (2007) hold a view of an integrated account of language comprehension and production, whereby people actively use processes involved in production in order to guide their comprehension, and vice versa. They argue that comprehension and production have to be seen together, because comprehension involves production processes, and not 'feedback' within the comprehension system (Pickering & Garrod, 2013a; Pickering & Garrod, 2013b). They argue that listeners make predictions about the upcoming speech before they actually hear it (Pickering & Garrod, 2013a) and those predictions are based on the forward models of action perception: that is, observers make the predictions about what is about to happen next based on covertly imitating what they would do in a given situation. Pickering and Garrod (2013a) argue that language comprehension is one type of action perception and that listeners also can covertly imitate the incoming speech to understand the intention of the speaker, and then use this information to predict the

upcoming speech in terms of the meaning, sounds, and grammar. This ability to map the information is a part of the forward model involved in the production system (Pickering & Garrod, 2013b). They point out that, as a result, people's ability to comprehend is affected by their ability to produce.

2. Use of ERPs in language production research

Traditionally, ERPs have been used extensively to study language comprehension, rather than production. This is because it was believed that the associated muscle movements would introduce too much noise into the data, making the subtle cognitive effects of interest impossible to detect. That is why, in the initial EEG production studies, different techniques were used. One of them was the investigation of lateralized readiness potential, which is thought to index response preparation. Those studies (for example, Rodriguez-Fornells et al., 2002; Schmitt et al., 2000) indicated a serial sequence of retrieving various representations: retrieving its semantic and lexical representations followed retrieving the picture's conceptual representations, which was then followed by its phonological representations. The problem with that methodology is that due to a delay in naming the picture and the complex tasks participants had to perform, it is impossible to conclusively know the exact timing of retrieving those various representations in a context of natural language production. Another technique involved measuring ERPs to auditory probe words presented with a delay after the onset of a picture (Jescheniak et al., 2002). Participants were cued to produce the name of a picture, after a delay of 1350 ms after its onset. The N400 appeared between 400-800 ms and was attenuated to semantically related, rather than unrelated, probe words. The authors concluded the semantic priming of the word by the picture's conceptual/lemma representation. When participants were asked to make a button press response to the picture, rather than naming them, a similar pattern was found, which suggests that the access to conceptual/lemma representations when naming a picture is similar to accessing these representations when making a button press semantic judgment task. This suggests that accessing the conceptual/lemma picture representations during naming (that is, word-level semantic processing) is similar to accessing these representations during a semantic judgment task (as described by Blackford et al.,

2012). This is in line with the view that these levels, and the stage of word-level semantic processing, are shared between comprehension and production (Levelt et al., 1999).

In more recent years, studies have emerged which use ERPs in language production tasks, which are time-locked to target stimuli. It takes a while to actually name the picture or the word, and so the artefacts due to muscle movements involved in naming do not typically affect the major components of interest as they happen before people start talking.

Three studies investigated the production of high and low frequency words. Laganaro et al. (2009) found that the ERP waveforms begin to diverge around 270 ms after the onset of a target picture. Strijkers et al. (2010) and Strijkers et al. (2011) reported the divergence to start within the P2 window, between 150-200 ms after the presentation of a target picture. In only one of those studies, early and balanced bilinguals were tested (Strijkers et al., 2010). In their study, Catalan-Spanish adults were asked to name pictures, which were either cognate words or not. Their aim was to index the beginning of the lexical access in word production by directly comparing the ERP waveforms in response to word frequency and cognate effects in individuals naming pictures in their L1 and L2. They did not aim to investigate specific ERP components, but rather the time in which the ERP waveforms begin to diverge. Costa and colleagues (2009) asked participants to produce names of picture from a set of mixed semantic categories and measured ERPs to pictures from a particular category that either appeared earlier or later within the presented set of images. They found that the ERP waveforms started to separate around 200 ms after the onset of the target stimulus. A similar result was earlier found by Maess et al. (2002) in an MEG study that looked at the difference of naming pictures that appeared within an intermixed or the same semantic category picture set. The above studies suggest that people's intention to produce words might produce some top-down activity, which then enables early access (around 200 ms after the onset of a target stimulus) to different linguistic representations (Strijkers et al., 2011).

However, the main aim of our study was to investigate the effects of comprehension and production within the N400 window. To the best of our knowledge, only 3 previous studies investigated the N400 distribution to pictures in a naming task. Chauncey and colleagues (2009) recorded ERPs that were time locked to a target picture, in a masked priming paradigm. The word primes were either corresponding to the name of the picture target or not. They found a modulation in the 300-500 ms window, with a more attenuated N400 to pictures with a corresponding prime. The second experiment showed cross-language priming in a similar masked priming paradigm. Bilingual participants saw the prime word in their first language, and were asked to name the picture in their second one. The distribution of the N400 was similar as in the first experiment. However, it is important to mention that the participants in this experiment were not balanced bilinguals. They were native speakers of English with a very late exposure to French (they did not have any significant exposure to French before starting high school). The assessed proficiency of their L1 and L2 showed significant differences. Koester & Schiller (2008) investigated morphological priming in a picture naming experiment in a long-lag priming paradigm. Their participants were Dutch monolingual speakers. They used compound words as primes, which were either morphologically related (semantically transparent or opaque) to a picture name or formed related monomorphemic words. They found an attenuated N400 in the 350-650 ms time window in response to pictures, which followed morphologically related transparent primes, compared to the unrelated ones. Similar distribution of the N400 was found when pictures were preceded by the morphologically related opaque primes. Blackford et al. (2012) argued that the N400 modulation in this study was partly due to the access to some more abstract word-level representations, rather than just the picture's conceptual features. It is important to emphasise that in study by Chauncey et al. (2009) and by Koester & Schiller (2008), the obtained N400 effect was similar to what would we expect in comprehension studies. Blackford et al. (2012) argued that the N400 in picture comprehension and production tasks involves processing at both the conceptual and the more abstract word-level (lemma) representations. Finally, in another masked priming picture production experiment, Blackford et al. (2012) aimed to

examine whether the behavioural pattern of the semantic interference effect would be echoed in the distribution of the N400. They argued that if the effect were mirrored (i.e. with a larger N400 to a target picture which followed semantically related word, compared to unrelated), it would provide the evidence in favour of Levelt's (1999) argument that the selection is made on a competitive basis at the conceptual-lemma representations. If the opposite were found, it would mean that the more abstract word-level (lemma) representation of the target picture was automatically primed by the context word, supporting the argument that the selection is made past the lemma stage. In their study, Blackford and colleagues (2012) manipulated content at different stages of representation in order to determine how those manipulations would influence word production. They found that in a condition where pictures were preceded by their names (as opposed to unrelated words), a smaller N400 and shorter naming latencies were seen. When a word with the same phonemic onset (as opposed to different) as the following picture was presented, shorter naming latencies were observed although there were no detectable changes within the N400 range. Finally, and most interestingly from the point of view of the present study, when pictures were preceded by semantically related (as opposed to unrelated) words, a less negative N400 and longer naming latencies were observed. The authors have concluded priming has occurred past the lemma-selection stage, at the level of semantic processing of the entire word. Therefore, Blackford and colleagues (2012) argue that their results go against Levelt's model of word production, which assumes sequential processing of all stages and therefore argued that only selected lemmas move along in the process and enter the phonological encoding phase. The authors suggest a more interactive approach to language production, in which later stages of processing are subjected to some feed-forward effects of competing semantic information.

3. The present study

There are not many studies, which investigated production using ERPs, and generally all of them have looked at different aspects involved, such as word frequency effects (Strijkers et al., 2011), or frequency and cognate effects (Strijkers et al., 2010). There are even fewer of such studies, which looked at the performance of early, balanced

native-like individuals (Strijkers et al., 2010). Again, the aims of those studies were very different from what we set out to investigate. The main aim of our study was to directly compare comprehension with production and the potential changes in the N400 window, in order to partially explain the effects found in Chapter 4. Therefore, it is reasonable to suspect that the electrophysiological patterns elicited in this study (that is, a direct comparison of comprehension and production blocks of words and pictures, with the focus on the effects on the N400) will in fact, be very different from what has been shown before.

Methods

Participants

Twenty adult highly proficient and balanced Basque-Spanish bilinguals (12 females and 8 males, mean age: 20.1 years old) participated in the study. All were students at the University of the Basque Country, and received monetary compensation for their participation. According to the Edinburgh Inventory for assessment of handedness (Oldfield, 1971) they were all right-handed. They had normal or corrected to normal vision. None of them reported to have any reading difficulties.

We decided to test balanced bilinguals, even though the study did not involve any language manipulations, meaning that it was conducted entirely in Spanish. The bilingual population was chosen for two reasons. Firstly, even when using only one language, it has been argued that bilinguals constantly have to inhibit their second language. It has also been suggested that both languages are active in the bilingual brain at all times, even though only one might be explicitly at use. Therefore, it is reasonable to suggest that even when performing the task in one language only, bilinguals will process the information differently than monolinguals. Secondly, as this study relates to the modality-switch component of translanguaging (Chapter 4), which by definition focuses exclusively on bilinguals, we were interested to see how such a specific population will perform in a comprehension-production switch task. Specifically, we aimed to establish whether any of the effects obtained in the main translanguaging study

(Chapter 4) could be explained when only the modality-switch component is considered (without the language-switch), in a similar population.

Due to the balanced and frequent exposure at home, school and the general environment to both Basque and Spanish from birth, which characterised our highly proficient bilingual participants, it is impossible to determine which language is ‘dominant’ or ‘native’, and which is the ‘second language’. Therefore, we have decided not to refer to our participants’ languages as L1 (first language) and L2 (second language), and instead refer to Basque and Spanish (see Perea et al., 2008, and Guasch et al., 2011 for a similar decision in the case of their Basque-Spanish and Catalan-Spanish bilinguals, respectively).

Materials

The experiment was carried out in Spanish. 40 line drawings were selected from the Snodgrass and Vanderwart’s (1980) picture database. They all depicted common and highly familiar objects. Their labels were also given in Spanish, in blocks that included only written words. Additionally, a database of 40 highly familiar and frequent words was created. They were used to create related and unrelated word-word and word-picture pairs. All of the stimuli were presented on a black background with white line drawing. Words were presented in Times New Roman white font, size 24, on a black background.

Participants were seated in front of a monitor screen and a microphone and were asked to use two buttons on the keyboard to specify their responses (i.e. whether the pairs were related in meaning or not).

Procedure

A computer with Windows XP operating system and Presentation software (Version 16.0; www.neurobs.com) were used to present the stimuli. Participants were instructed about the EEG procedure and seated comfortably in a quiet room.

It is common in picture-naming experiments to create a ‘familiarisation’ phase before the start of the experimental trials in order to increase object-naming agreement across participants. In the present study, participants viewed all the line drawings, one by one, together with their names (written at the bottom of each item) before start of the experiment, and were additionally asked to name them out loud.

Before the actual experiment, participants ran a short practice session of 6 trials in each of the 4 blocks. The stimuli used in the practice run did not appear again in the actual experiment.

Participants viewed 4 blocks of 160 stimuli each. The primes were always Spanish words, and the targets were either pictures (in 2 blocks) or Spanish words (in 2 blocks). They were arranged in semantically related and unrelated pairs. The majority (over 80%) of the stimuli were the same as in the previously published studies by Perea et al. (2008) and Guasch et al. (2011). The relatedness of the remaining word-pairs was determined by a group of native Spanish speakers, who were asked to indicate whether the presented word-pairs were related in meaning or not. The prime appeared on the screen for 300ms, followed by the target picture or word which stayed on the screen for up to 2000ms or until participants had made the response. There was a variable ISI (inter-stimulus interval) between the prime and the target between 450-700ms, in steps of 50 ms. On the trials that required participants’ verbal response first, it was followed by their other response about the relatedness, which also lasted for up to 2000ms. The pairs were separated by a fixation cross. Please see Figure 28 (below) for a graphical representation of the experimental procedure.

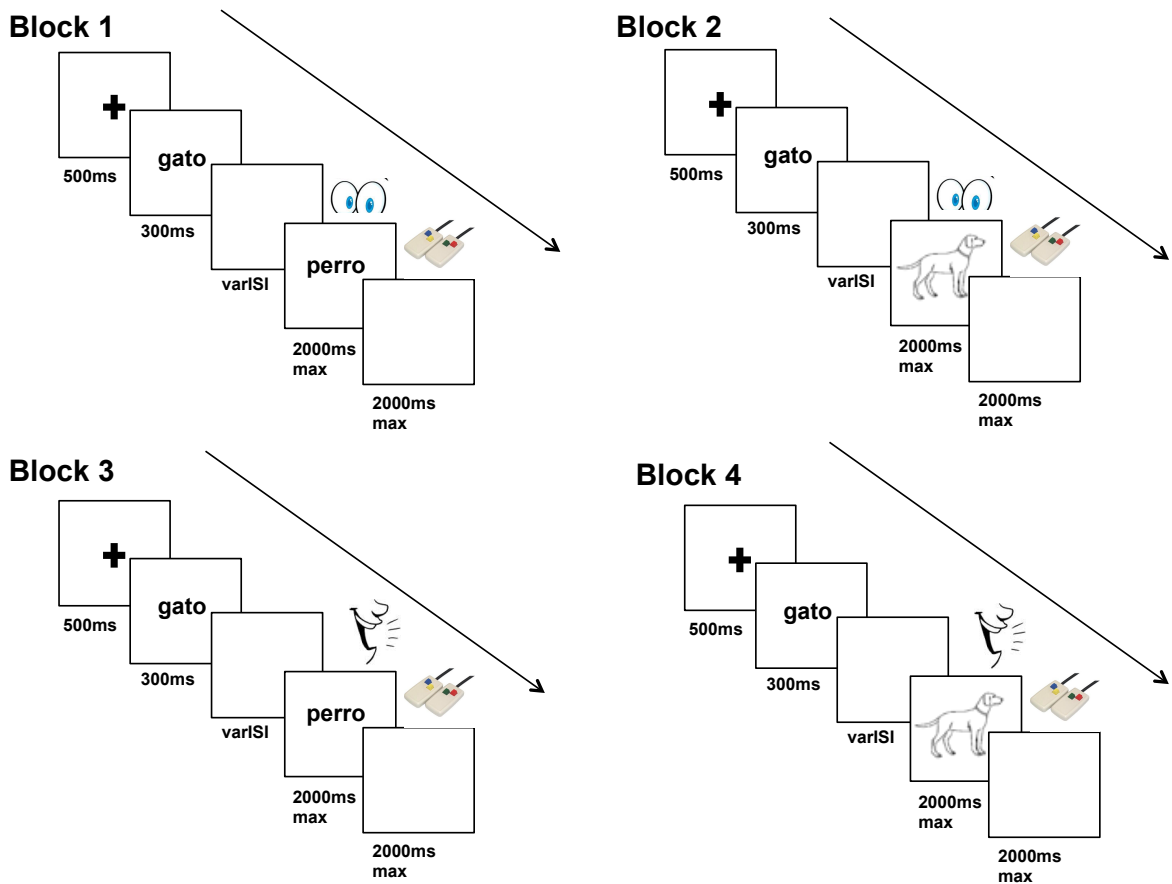

Figure 28. A graphical representation of the experimental procedure. The order of blocks was counterbalanced across participants. The varISI stands for variable inter-stimulus interval, and was between 450-700 ms, in steps of 50 ms.

Please see Table 9 (below) for examples of word-word and word-picture pairs manipulations. The study fitted into a 2x2 ANOVA, with relatedness (related, unrelated) and modality (comprehension, production) as factors. Words and pictures were analysed separately.





Condition	Prime	Target	Relatedness	Mode	Target type
1	vaca	leche	+	Comp	Word
2	huevo	gallina	-	Comp	Word
3	llave	puerta	+	Prod	Word
4	manzana	naranja	-	Prod	Word
5	árbol		+	Comp	Picture
6	león		-	Comp	Picture
7	mesa		+	Prod	Picture
8	mono		-	Prod	Picture

Table 9. Examples of the stimuli used in the 8 conditions of the experiment. In the *relatedness* column, a ‘+’ indicated semantically related, whereas a ‘-’ semantically unrelated pairs. In the *mode* column, *comp* stands for comprehension, and *prod* stands for production. For reader’s information, give the Spanish-English translations of the stimuli from the table: vaca = cow, leche = milk, huevo = egg, gallina = chicken, llave = key, puerta = door, manzana = apple, naranja = orange, árbol = tree, león = lion, mesa = table, mono = monkey

EEG recording

The electroencephalogram (EEG) was recorded from 64 active electrodes placed securely in an elastic cap (Acticap System, Brain Products, Gilching, Germany). Electrodes were distributed on standard positions according to the extended International 10/20 system. All recordings were referenced online to Cz, and off-line to the global average. Vertical and horizontal eye movements were monitored with the use of two additional electrodes. One of them was placed just underneath, and one in the corner of the right eye. The impedance was kept below 10 kOhm at all scalp and eye electrodes. The electrical signals were digitized in-line at a rate of 500 Hz by a BrainAmps amplifiers system and filtered off-line within a bandpass of 0.01-35 Hz. After the EEG data were recorded, the ocular correction procedures as well as the artifact rejection were applied off-line, using the algorithm provided in ERPLAB.

Data analysis

As mentioned before, words and pictures were analysed separately.

For the ERP measures, segments were created from 100 ms before to 700 ms after the onset of the target stimulus. The trials associated with each block were averaged for each participant. Afterwards, the data was subjected to a 2x2 ANOVA analyses, with relatedness (related, unrelated) and modality (comprehension, production) as factors.

As this was a typical priming experiment, with the focus on the N400 effects, the strongest effects were expected to occur within the centro-parietal sites (for words), and the fronto-central sites (for pictures). This predictive approach was based on the extensive N400 literature available to date (see Kutas & Federmeier, 2011, for a review).

Results

Due to the equipment malfunction, the data for one of the participants had to be discarded from the *behavioural* analysis. Therefore, the behavioural results here are for the 19 remaining participants.

In the *electrophysiological* analysis, all 20 participants were included. As expected, the N400 effect was maximal at fronto-central electrodes for pictures (FC1, FC2, FCz, C1, C2, Cz, F1, F2, Fz) centro-parietal sites for words (FC1, FC2, FCz, C1, C2, Cz, CP1, CP2, CPz). Surprisingly, the earlier effects (within the N1 and P2 windows) were also most prominent in the same regions.

Words – Behavioural data

A 2 x 2 ANOVA, with relatedness (related, unrelated) and modality (comprehension, production) was conducted. As expected, the results showed a main effect of relatedness [$F(1,18) = 29.033$, $p = 0.000$], such that participants' responded faster to related, as opposed to unrelated, targets. There was no main effect of modality [$F(1,18) = 2.472$, $p = 0.133$]. A relatedness x modality interaction also yielded significant results, [$F(1,18) = 7.688$, $p = 0.013$]. In related items, the obtained difference is smaller across the

modalities than with unrelated items. The nature of the interaction is such that the effects of relatedness are actually much larger when participants had to comprehend words than when they had to produce them. Figure 29 (below) shows a graphical representation of participants' responses.

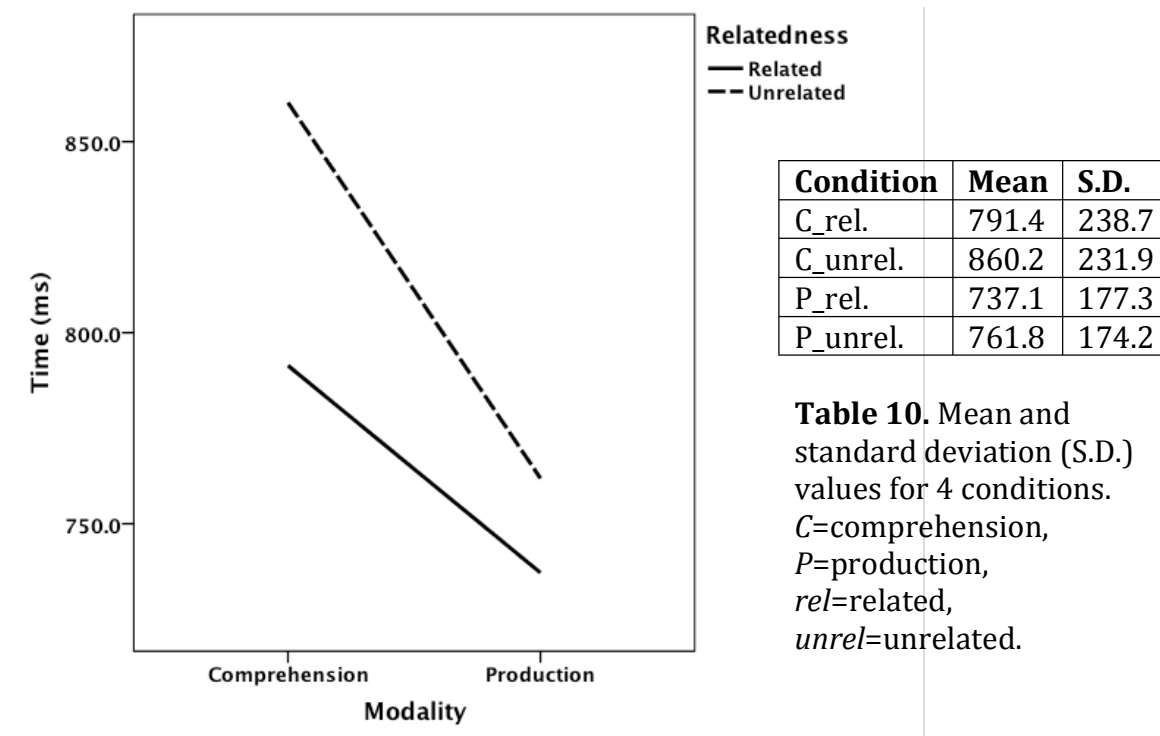

Figure 29. A plot representing participant's mean reaction times to target words. In comprehension, button press reaction times were measured. In production, we measure the onset of participants' verbal response.

Words – Electrophysiological data

The following 9 electrodes were used for the purpose of statistical analyses: FC1, FC2, FCz, C1, C2, Cz, F1, F2, Fz for pictures, and FC1, FC2, FCz, C1, C2, Cz, CP1, CP2, CPz for words. The ERP waveforms shown on the grand average ERP graphs below represent the results from only of the electrodes (here, FCz) as an example of obtained data.

The visual inspection of the data within the N1 window (80-120ms) suggests a tendency of comprehension eliciting larger effects than production. However, no statistically significant effects of modality were found [$F(1,19) = 1.726, p = 0.204$].

Within the P2 window (140-180ms), there was a main effect of modality, with production inducing a significantly larger positivity [F(1,19) = 5.138, p = 0.035]. Finally, within the N400 window (300-400ms), there was a main effect of relatedness, with unrelated word-pairs inducing a significantly larger negativity than related ones [F(1,19) = 8.098, p = 0.010], and a main effect of modality, with production inducing a significantly larger negativity than comprehension [F(1,19) = 7.839, p = 0.011]. The interaction between relatedness and modality was not statistically significant [F(1,19) = 3.506, p = 0.077]. See Figure 30, below, for the ERP waveforms elicited in response to words.

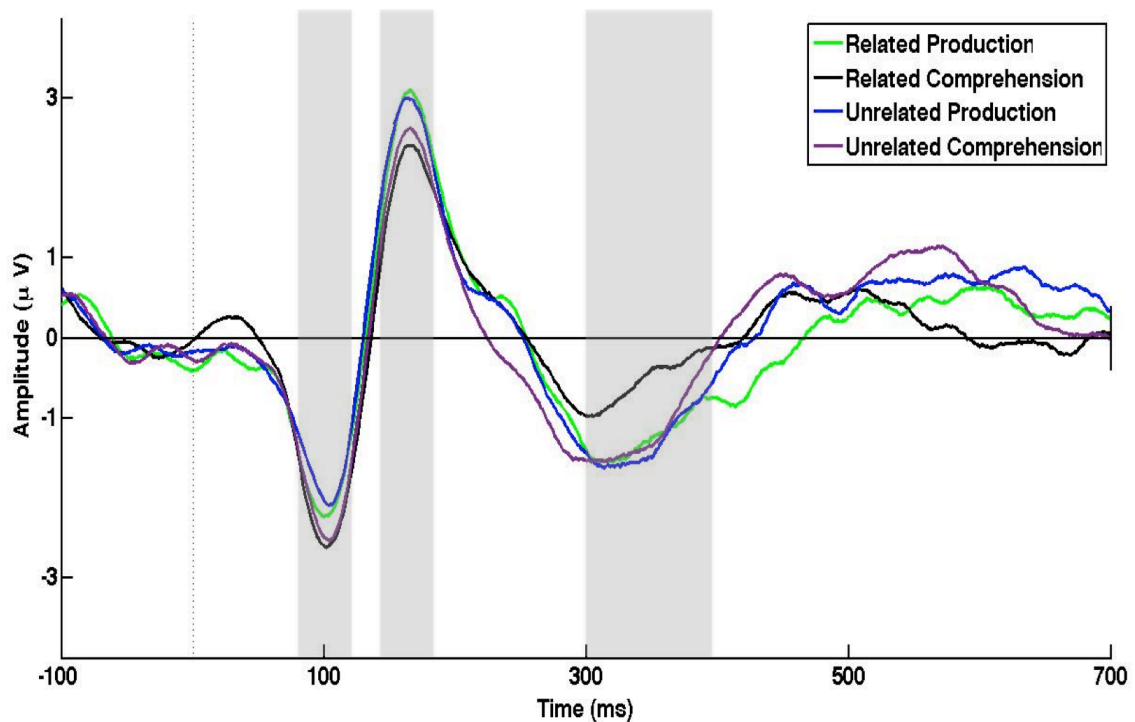

Figure 30. Grand average ERPs elicited in response to words (here, we chose the FCz electrode as an example of one of the electrode sites selected for the statistical analyses) to illustrate the ERP components of interest).

Below (Figure 31) we present the grand average ERPs on the channels selected for the statistical analyses (with the exception of FCz, which is enlarged and shown in Figure 30 (above) as an example).

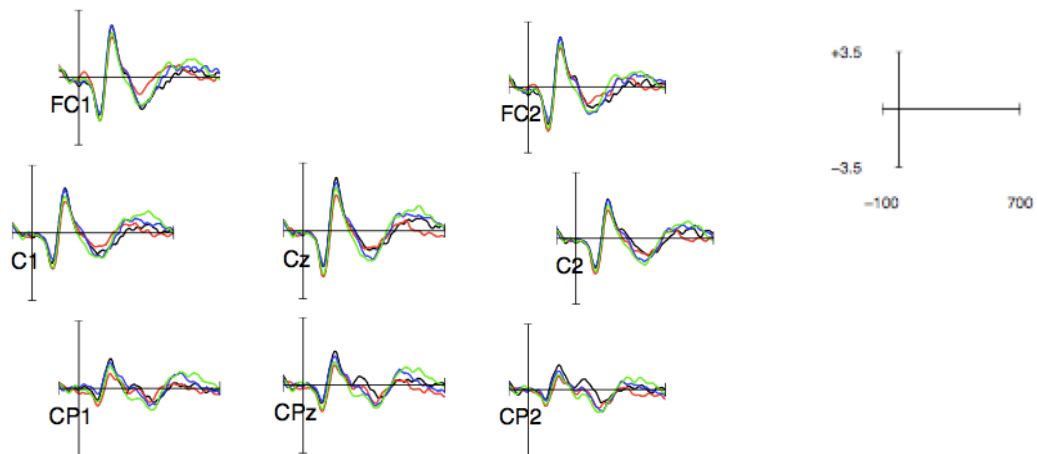

Figure 31. Grand average ERPs on electrodes of interest, which were chosen for the statistical analyses (with the exception of FCz, which is enlarged and shown above in Figure 30 as an example). Each waveform colour corresponds to those presented in Figure 30.

Below (Figure 32), we present topographical maps elicited in response to words, in 4 of the conditions of interest, to match the data presented above (Figure 23) as the ERP response waves: related production (row A), related comprehension (row B), unrelated production (row C), and unrelated comprehension (row D). Within each of those figures, we present the data for 3 time points: 80-120 ms, 140-180 ms, and 300-400 ms.

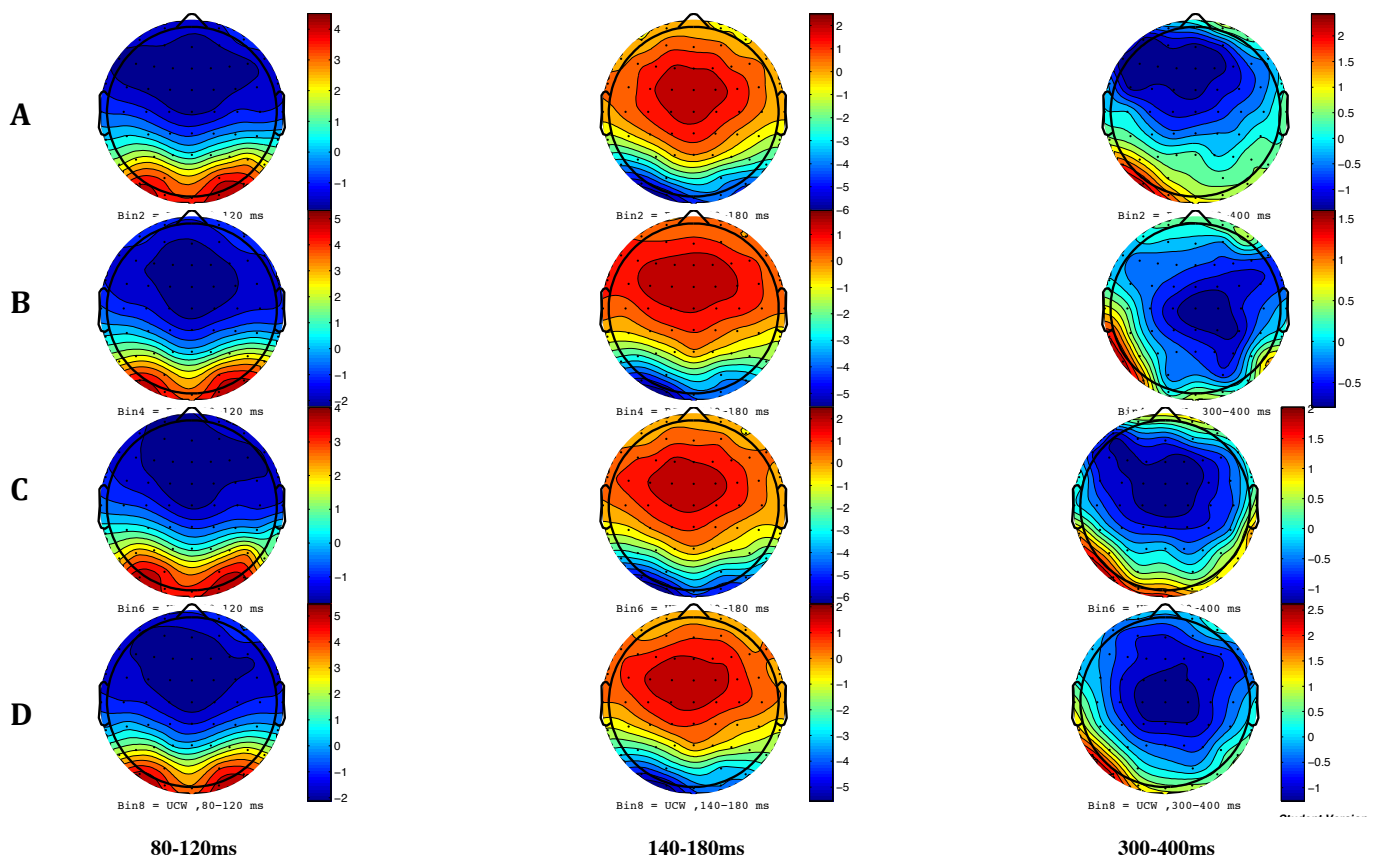

Figure 32. Topographical maps in response to words for each experimental condition: related production (row A), related comprehension (row B), unrelated production (row C), and unrelated comprehension (row D). The first column shows the data for the N1 components (80-120ms), the second column shows the data for the P2 component (140-180ms), and the third column shows the data for the N4 components (300-400ms).

Pictures – Behavioural data

The results of a 2 (relatedness: related, unrelated) x 2 (modality: comprehension, production) ANOVA showed main effect of relatedness [$F(1,18) = 28.414, p = 0.000$], such that participants' responded significantly faster to related, as opposed to unrelated, pairs. There was also a main effect of modality [$F(1,18) = 6.506, p = 0.020$], such that participants' reaction times were faster when they had to silently comprehend target pictures and make a relatedness decision, as opposed to when they had to name the target pictures out loud. No significant modality x relatedness interaction was found, [$F(1,18) = 0.005, p = 0.944$]. Figure 33 (below) represents participants' mean reaction times in response to pictures.

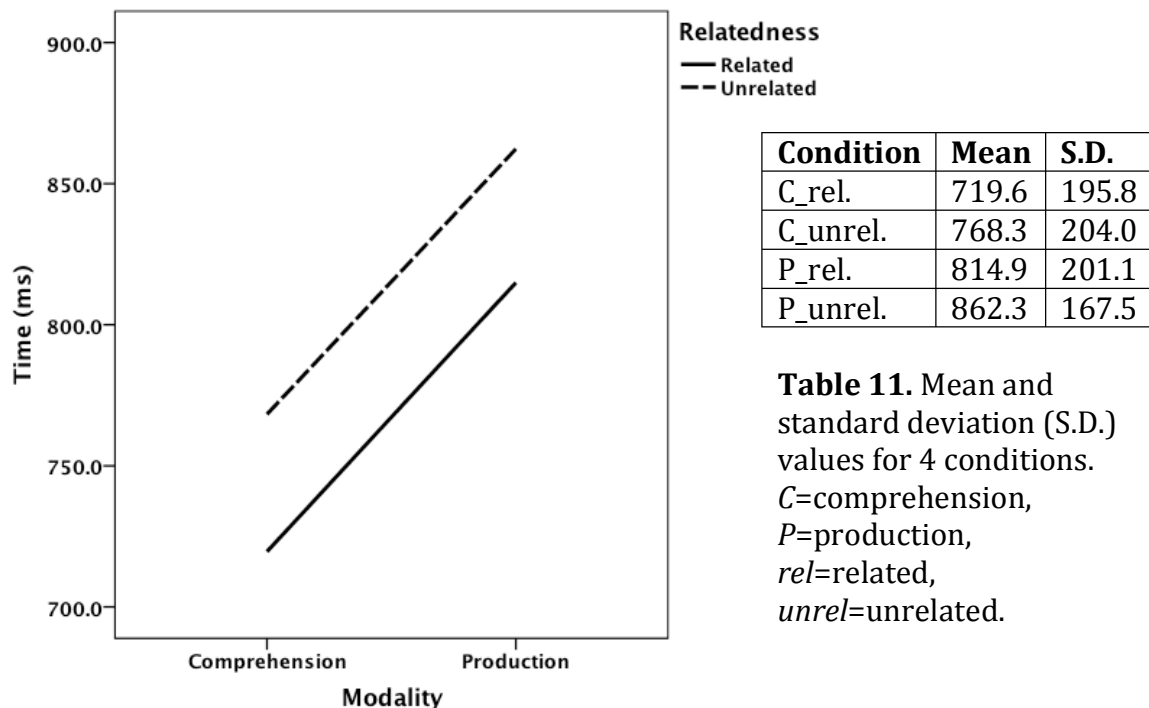

Figure 33. Participants’ mean reaction times in response to pictures. In comprehension, we measure the time of the button press response. In production, we measure the voice onset when participants had to name target pictures.

Pictures – Electrophysiological data

Within the N1 window (80-120ms), we found a main effect of modality, with comprehension inducing a significantly larger negativity than production [$F(1,19) = 9.017, p = 0.007$]. In the P2 window (140-180ms), there was a main effect of modality, with production inducing a significantly larger positivity [$F(1,19) = 5.258, p = 0.034$] and a main effect of relatedness, with related pairs inducing a significantly larger positivity than the unrelated ones [$F(1,19) = 10.787, p = 0.004$]. Finally, in the N400 component (200-300ms), we found a main effect of relatedness, with unrelated word-pairs inducing a significantly larger negativity than related ones [$F(1,19) = 13.608, p = 0.002$]. No main effect of modality was found in the N400 component [$F(1,19) = 1.046, p = 0.320$]. The interaction between relatedness and modality was not statistically significant [$F(1,19) = 0.391, p = 0.540$]. See Figure 34, below, for the ERP waveforms elicited in response to pictures.

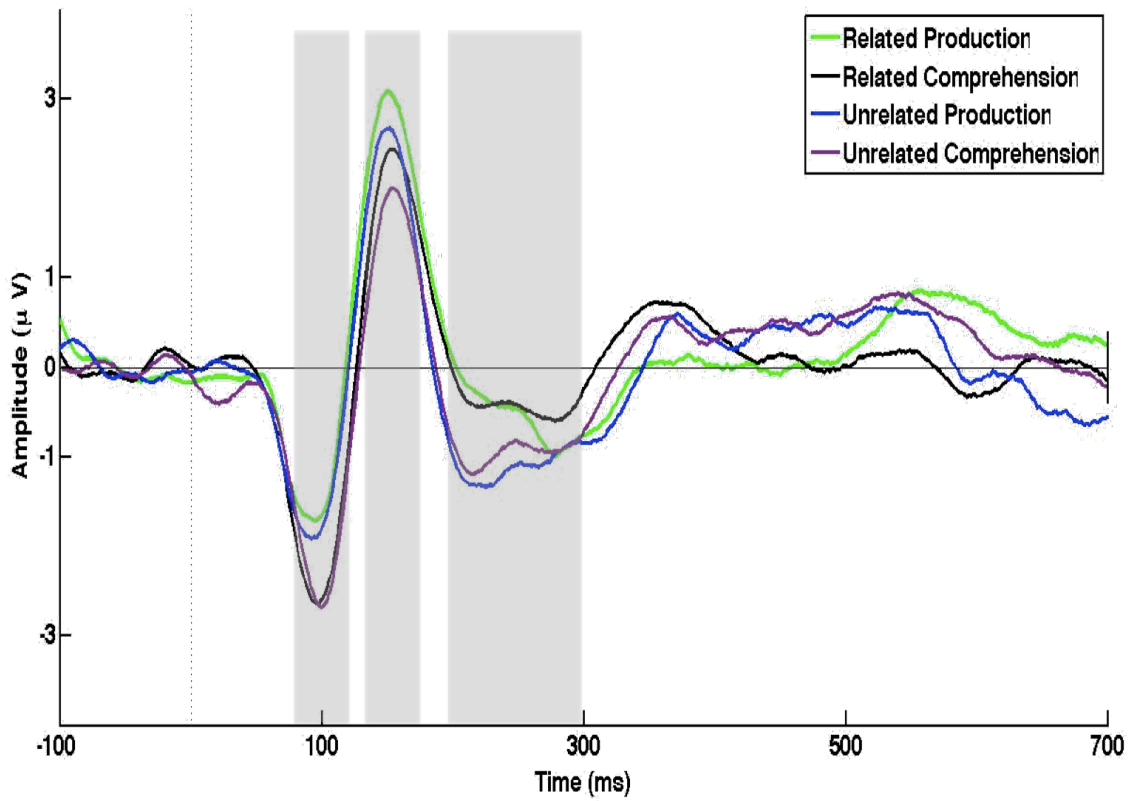

Figure 35. Grand average ERPs elicited in response to pictures (here, we chose the FCz electrode as an example of one of the electrodes selected for statistical analyses) to illustrate the ERP components of interest).

Figures 36 (below) shows the grand average ERPs elicited on 9 electrodes selected for the statistical analyses in response to words.

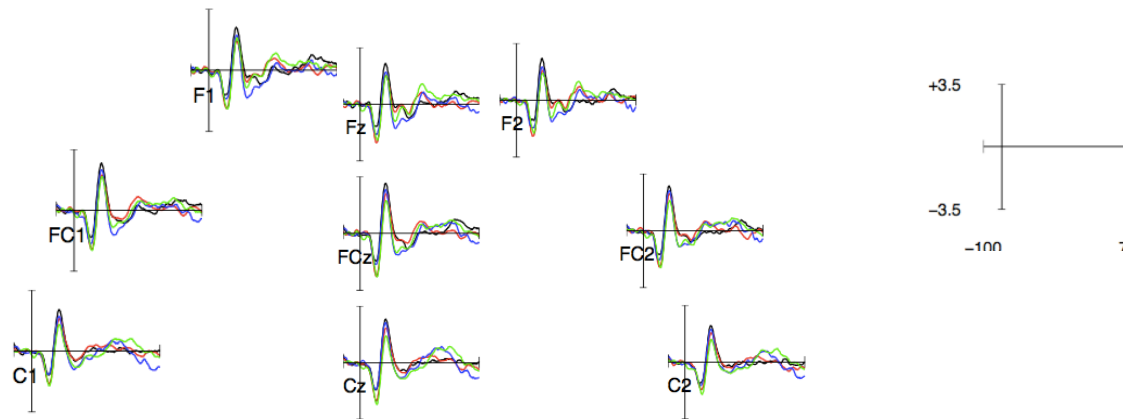

Figure 36. Grand average ERPs on the 9 electrodes of interest, which were chosen for the statistical analyses. Each waveform colour corresponds to those presented in Figure 30.

Below (Figure 37), we present topographical maps elicited in response to pictures, in 4 of the conditions of interest, to match the data presented above (Figure 23) as the ERP response waves: related production (row A), related comprehension (row B), unrelated production (row C), and unrelated comprehension (row D). Within each of those figures, we present the data for 3 time points: 80-120 ms, 140-180 ms, and 200-300 ms.

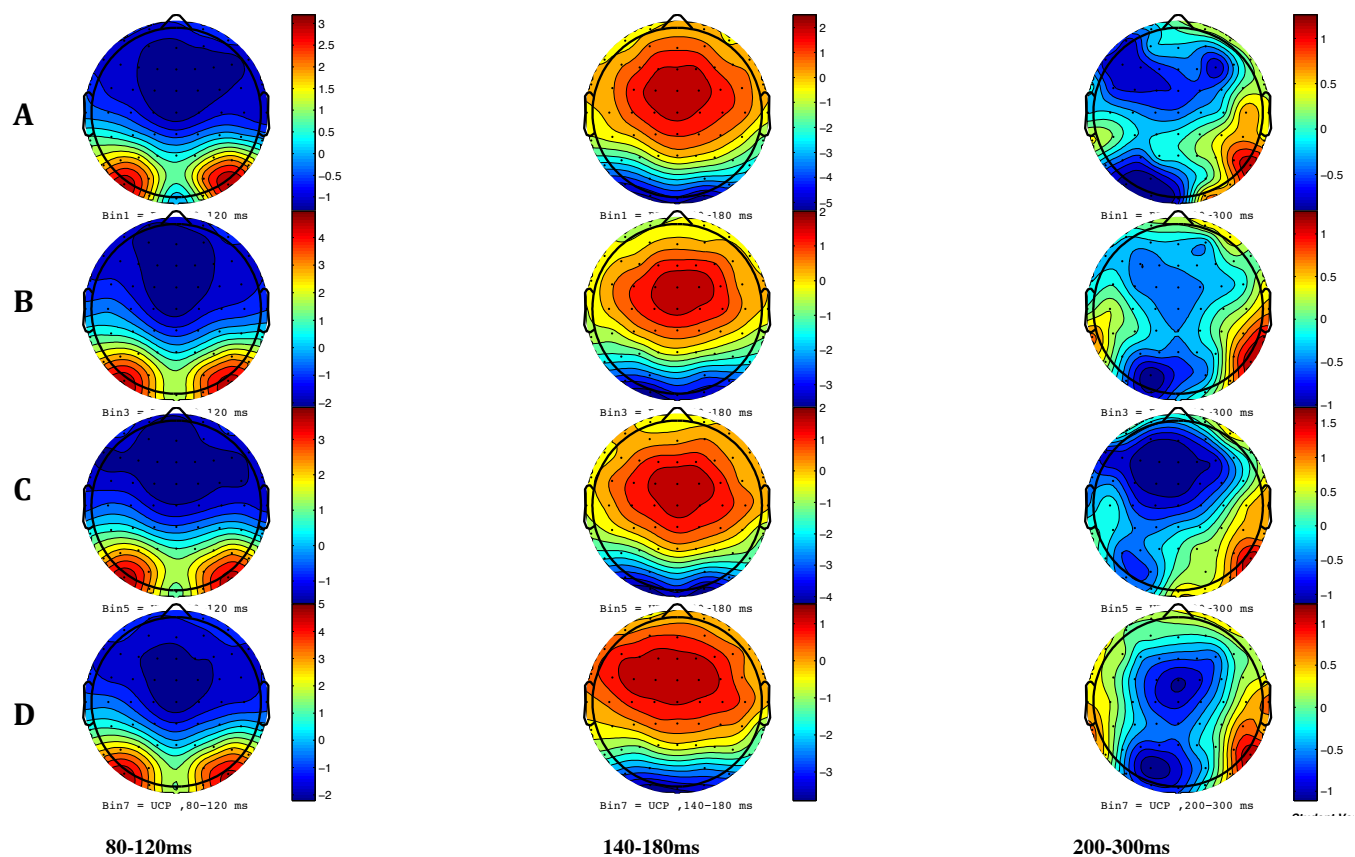

Figure 37. Topographical maps in response to pictures for each experimental condition: related production (row A), related comprehension (row B), unrelated production (row C), and unrelated comprehension (row D). The first column shows the data for the N1 components (80-120ms), the second column shows the data for the P2 component (140-180ms), and the third column shows the data for the N4 components (200-300ms).

Discussion

The aim of this study was to investigate the processes involved in going from comprehension to production, the so-called modality-switch, in words and pictures. Specifically, we were interested whether any effects obtained in this study would explain the overall effects found in the main translanguaging study (Chapter 4) within the N400 window. As we were interested in the possible impact of modality-switch on the semantic integration, we designed a classic priming paradigm, in which participants were asked to decide with a button press whether the target word/picture is related to the

preceding prime, or name it out loud first and then make a relatedness button-press response.

Behavioural effects

As expected, in line with extensive priming literature (see McNamara & Holbrook, 2003, for a review), behavioural results for both words and pictures showed that participants' were faster to respond to related, as opposed to unrelated, targets. Semantic priming paradigms have consistently found that the recognition of a target is faster and more accurate when it is preceded by semantically related, as opposed to semantically unrelated, prime. Behavioural results also showed significant differences between comprehension and naming of pictures, such that spoken production of a picture name took longer than its comprehension. This is not surprising, as production is generally more difficult than encoding because it is easier to understand something than to speak it. Additionally, naming pictures is known to create difficulties. Previous literature suggests that when overt naming is required, latencies to name pictures are longer than latencies to name words (Potter & Faulconer, 1975; Potter et al., 1986; Riès et al., 2012).

A significant related by modality interaction was also observed for words, suggesting that the participants' relatedness responses are modulated, in some way, by the effects of modality. Specifically, the effects of relatedness were smaller when participants were asked to produce words rather than when they had to comprehend them. Participants were fastest when producing related words, followed by producing the unrelated words. They took the longest time to comprehend the unrelated items, followed by their comprehension of related items.

ERP results – later components

As expected, the ERP results showed the N400 effect modulated by relatedness in both words and pictures, such that related pairs resulted in an attenuated N400 than unrelated ones, which is in line with the N400 literature (see Kutas & Federmeier, 2011, for a review). Additionally, the N400 in words was also modulated by modality, such that

production of words induced a significantly larger N400 than their comprehension, suggesting that more processing effort was required to read the words out loud rather than silently. We did not observe a similar effect in pictures. The results on the N400 reduction when target picture or word was preceded by semantically related, as opposed to unrelated, primes, are in line with the extensive N400 literature. This reduction in the amplitude of the N400 is thought to mirror reduced semantic processing of that target because its representation is pre-activated by the context (Kutas & Federmeier, 2011). It is important to stress here that the modulation of the N400 does not depend on participants' behavioural responses. In fact, it is not uncommon to see the reduction of the N400 in the presence of behavioural inhibition (Holcomb et al., 2002). When processing pictures, the N400 is sometimes preceded by the N300 (McPherson & Holcomb, 1999), which is a frontally distributed component that reflects access to the structural semantic features specific to picture recognition. It is different from the later N400, which reflects semantic processing that happens at the interface between the conceptual features and a more abstract level of representation. However, in our study we did not observe the N300 followed by the N400; instead, we observed an N400 in an earlier than usual time window (200-300 ms).

ERP results – early components

Apart from the effects within the N400 window, we also observed earlier effects in both words and pictures. Firstly, there was a tendency for comprehension, as opposed to production, to result in a larger waveform within the N1 window, however this effect was statistically significant only in pictures. This is interpreted as comprehension requiring more effort in the earliest stages of processing. Secondly, in both words and pictures, we found a significant main effect of modality within the P2 window, with production resulting in a larger positivity, as opposed to comprehension. Those later (P2) effects are in a sharp contrast to the earlier (N1) effects, suggesting that people's intention to speak impacts on the ERP waveforms, such that it results in a more processing effort, from around 120ms after the onset of a target. Additionally, there was also a significant effect of relatedness in the P2 component in pictures, such that related objects had an increased positivity than the unrelated ones. As the N400 effect in

pictures appeared very early (200-300 ms after the onset of a target stimulus), it is possible that the relatedness modulation in the P2 and N400 windows is in fact the same effect.

The earlier components are typically elicited upon presentation of any visual stimulus. A number of studies investigating high and low frequency picture names have found effects starting to appear in the early time windows, around 270 ms after the picture onset (Laganaro et al., 2009), or 150-200 ms after the onset of a target picture (Strijkers et al., 2010; Strijkers et al., 2011; Costa et al., 2010). Bilingual individuals also show this early divergence when they name pictures that share (or do not share) phonological features across two languages (Strijkers et al., 2010). However, unlike in our experiment, none of those studies directly compared comprehension and production of the same stimuli in bilingual participants. In the present study, we observed differences in the amplitudes of those early components in comprehension and production. This suggests that the intention to speak has an impact on the ERP waveforms almost immediately after the presentation of target stimuli, with the divergence of the waveforms starting as early as 80 ms. According to Indefrey & Levelt (2004), lexical access is thought to take place around 150-275ms, which is when the first statistically significant difference for both words and pictures appeared in our study. This suggests that the lexical access is different when participants have the intention to speak.

As mentioned in the introduction, some earlier studies that have measured ERPs to probe words, found a similar pattern when naming pictures and when just comprehending them and making a button-press semantic judgement task. Those findings were in line with the assumption that accessing conceptual/lemma picture representations during naming is comparable to accessing these representations during a semantic decision task, suggesting that these levels are shared between comprehension and production (Levelt et al., 1999). In our study, the ERP pattern found in comprehension and production was very different, with the waveforms starting to diverge as early as 80 ms after the presentation of a target. However, it is possible that

those different results are due to differences in the design of the experiment, and the fact that our study used ERPs time-locked to a target stimulus, rather than to probe words.

Issues to be considered when interpreting this dataset

There are two issues that have to be considered when analysing this data, namely the timing of the effects and their distribution.

First, let's consider the time windows of the observed effects. The latency of the obtained N400 effects in this study might seem a bit early, when considered the fact that most of the literature commonly reports the N400 to peak around 400 ms after the onset of the target stimuli. Here, the effect for words was most prominent between 300-400 ms, and for pictures between 200-300 ms after the onset of the target. It is important to remember that the N400 effect has been characterised as the negative-going wave of activity, occurring between 200-600 ms elicited in response to incongruent (such as unrelated), rather than congruent (such as related) stimuli (Kutas & Federmeier, 2011; Kutas & Iragui, 1998). Kutas & Iragui (1998) found that starting as early as 200 ms after the onset of the stimuli, the ERPs measured to incongruent words were significantly larger than those measured to congruent words. They also found this effect to be strongest and appearing earlier in younger adults, and diminishing in amplitude as well as delaying in latency in older adults. Aparicio and colleagues (2012) tested trilinguals and found the semantic N400 to be between 250 ms and 500 ms after the onset of a target. The latency differed as a function of language, with the earliest effect associated with participants' first language, whereas participants' L2 and L3 had a tendency to peak together around the same time, within the 300-500 time window. Therefore, as our participants had essentially 'two L1s', the early effects we obtained are in fact in line with the effects found in the above studies. Indeed, Kutas and Federmeier (2011) argue that the N400 should be seen as a brain activity in response to given stimuli, appearing somewhere between 200 and 600 ms after the onset of said targets, with a particular morphology, and most importantly, a 'pattern of sensitivity to experimental variables – and hence a common functionality' (p.3).

Secondly, let's look at the distribution of the effects. As we were most interested in the potential effects of comprehension and production within the N400 window, we designed a typical priming paradigm. Therefore, we did not aim to perform any full scalp analyses when establishing the sites of interest, and instead used a predictive approach in which, based on the extensive N400 literature available (see Kutas & Federmeier, 2011, for a review), we expected the effect to be maximal over central electrodes. This, in fact, was true with relation to the N400 effect.

The earlier components that were observed in our study were also most prominent within the same sites. This is in some contrast to other production studies, which report the early activity within central and parietal regions, rather than central and frontal. This difference might be due to two issues. Firstly, the design of this study was very different from other production studies, in that it is the first experiment that looked directly at the comparison of comprehension and production of the same stimuli. Previous studies relied heavily on just the production component. Secondly, the participants' selection was, again, different from the majority of production studies. Most of other experiments focused on monolingual participants or learners of the second language. Early, balanced bilinguals are thought to be very skilled at inhibiting one language, and therefore it is possible that their responses are most prominent in the frontal regions, where inhibition takes place. Only one other study looked at production in early, balanced bilinguals (Strijkers et al., 2010). This study reported effect within the central and parietal regions, despite using a similar population in their experiment. However, the design of the study was very different, as they looked at the production of high and low frequency picture names, rather than comparing comprehension with production. Because of a very limited number of previous studies of production in early bilinguals, and no studies that would look at the concept of comprehension and production in this group of participants, it is impossible to say at this stage, with any certainty, what is behind the distribution of the effects found in this study.

Conclusion

To the best of our knowledge, this is the first study that directly compared the electrophysiology of comprehension and production of words and pictures. The results

show that the ERP waveforms start to diverge as early as 80 ms after the onset of the target stimulus. The first significant differences in both words and pictures were within the P2 window, with production inducing a larger positivity than comprehension. This suggests more effort in processing the lexical access of stimuli when participants have the intention to speak. Additionally, there were differences within the N400 component, modulated by relatedness in both words and pictures, suggesting more effort needed to integrate unrelated, rather than related stimuli, and by modality in word-blocks, suggesting that production of words was more effortful than their comprehension. The point in time where the comprehension and production effects induce significant differences (so where the ERP waveforms have significantly diverged) provides new insights with regards to the onset of lexical access.

Chapter 7

General discussion

1. Summary of the main results

In this thesis, I investigated the neural underpinnings of simultaneous language and modality (comprehension to production) switch, known as *translanguaging*, using event related brain potentials.

Based on the experiments included in this thesis, a number of conclusions can be drawn. Firstly, translanguaging successfully heightens the levels of conceptual engagement of the semantic system. When bilingual adults acquired completely new knowledge in either only one of their languages, or both of them, they showed different ways of processing this information at testing. Precisely, objects learned through translanguaging induced a significantly smaller N400 than those same objects learned through the medium of only one language. This is interpreted as evidence that using simultaneous language and modality alternation results in deeper processing and more meaningful learning.

Secondly, when those same participants were tested a few weeks later on the same information they acquired during the first session, the significant N400 effect of learning context still remained, such that pictures learned through the method of translanguaging induced a smaller N400 wave than those same ones learned in a monolingual fashion. It is important to emphasise that due to all of the pictures being novel and having completely made-up definitions, it was not possible for the participants to revise their knowledge in any way between the first testing session and the retesting. Additionally, the participants were not told that they would be coming in for the same testing session when they were invited to return. Instead, they were told that they are invited to take part in a new experiment. Therefore, the effect cannot be assigned to the fact that participants could prepare themselves for the retesting session, by trying to remember or revise what they had learned initially.

Thirdly, when tested on the language-switching paradigm early and highly balanced bilingual individuals showed a larger N400 when presented with mixed-language word

pairs, as opposed to same-language pairs. No typical semantic relatedness effect was observed, meaning that unrelated word pairs did not produce a larger N400 than the related ones. The results of this study indicate that more effort is needed to process language switch, as opposed to same-language pairs. As for the lack of semantic relatedness effect, those results put a shadow on the automaticity of this process. It is possible that participants were concentrating so much on their task, which was identifying animal words, that they did not automatically process the remaining words on a deeper, semantic level, and merely noticed whether there was a language change, suggesting that only lexical processing took place.

Fourthly, when participants were tested on a modality-switch paradigm, which aimed to investigate the processes involved in comprehension-to-production switch in balanced bilinguals tested in a monolingual fashion, the obtained results have failed to provide any adequate explanation about the findings of the main translanguaging study (Chapter 4). The effects of the experimental manipulations obtained in Chapter 6 begin to appear much earlier than those derived in Chapter 4, thus suggesting that translanguaging cannot be simply reduced to comprehension-production manipulations. It is important to emphasise that even though the participants in Chapter 6 were in fact early, balanced bilinguals, they performed the task exclusively in only one language (i.e. Spanish). The reason for such manipulation was to firstly establish the processes of purely modality-switch, before adding on another component of language manipulations, which would be the aim of future studies. Such gradual, bottom-up approach would be easier to disentangle the obtained effects and to explain them in the light of particular experimental manipulations.

Finally, the studies described in this thesis strongly suggest that acquiring new information through translanguaging results in stronger and better-established semantic associations and therefore easier processing of this information at testing. Furthermore, although translanguaging here has been defined as simultaneous language and modality alternation, the results show that this process cannot be reduced simply to the combination of its two separate aspects, namely language-switching and modality cross.

However, it is important to emphasise that the main translanguaging study (Chapter 4) measured medium- to long-term memory effects, because the participants had to successfully acquire new knowledge prior to testing (and retesting), whereas measures in Chapter 5 (language-switching) and Chapter 6 (modality cross) were online measures.

In the following section the results of the thesis will be summarised and discussed with regard to the research questions. After that, methodological issues will be discussed. Following that, practical implications and limitations will be considered and ideas for future research presented. Finally, the thesis will end with some concluding remarks.

In Chapter 1, I presented 6 research questions that this thesis aimed to answer. Below, I summarise the key findings for each research question, before expanding on them later. The first research question was addressed with a longitudinal study of translanguaging and answered in Chapter 4. The second and fifth research questions were discussed in response to the results of this study, also in Chapter 4. The third research question was investigated in Chapter 5 and 6. The fourth research question was partly discussed in Chapter 2 (literature review) and quantitatively answered in Chapter 5. The sixth research question was addressed in Chapter 4.

2. Review of the key findings

2.1.1 Research question 1 - *Mixing two languages in the same learning context is often considered detrimental. This stems from people's fear that such mixing can introduce confusion and therefore impact negatively on learning. The main question this thesis aimed to answer was whether this view is true. Precisely, the goal was to investigate whether learning through translanguaging, as opposed to monolingually, has any impact on people's learning?*

This research question was a focus of Chapter 4, which describes the longitudinal study of translanguaging. I believe that the results presented there can answer this research question with a firm: no, mixing two languages in the same context is not detrimental,

and learning through translanguaging has an impact on people's ability to process the *meaning* of what they have learned. Let's consider the findings of that study. In terms of participants' behavioural outcomes, they did indeed find translanguaging to be more challenging than monolingual learning. This was evident at the learning phase, in which they completed the learning of monolingual objects faster than translanguaging. It was also evident at testing phase, in which they took slightly longer to respond to objects learned via translanguaging. However, what is crucial to point out here, is that, firstly, those differences, although statistically significant, very in fact very small; and secondly, they all disappeared after a few weeks, whilst the N400 results remained. I believe that this really is the essence of translanguaging: whilst it might be harder to learn through translanguaging at first, it really yields good results later. The N400 modulation was clear and strong at both testing times, and showed that objects learned through translanguaging required less processing effort at testing. The initial difficulties in terms of behavioural, and therefore visible, performance disappeared with time and were replaced by virtually the same functioning in both monolingual and translanguaging situations. Therefore, it is my opinion, that translanguaging is not detrimental for learning, as seen in the behavioural and ERP results, and it impacts on people's learning in terms of their ease of integration of new information, as indexed by the N400 effect, meaning that they actually find it more difficult to process the knowledge learned in a monolingual fashion.

2.1.2 Research question 2 - *Is such impact negative, neutral, or perhaps positive?*

I believe that, in a way, all of those possibilities are true to some extent, based on the findings of this thesis. Some might argue that the initial difficulties that participants had in acquiring new information through translanguaging and during testing suggest a *negative* impact. Whilst it is clear that they, indeed, performed a bit better in a monolingual situation, this effect disappeared over time, meaning that participants' behavioural performance was comparable at re-testing. As there were no behavioural differences detected at all after a few weeks, we can say that this '*negative*' impact has

shifted and become ‘*neutral*’. In terms of the ERP waveforms, the results have always clearly suggested a *positive* impact of translanguaging on semantic integration, regardless of the behavioural effects, yielding a significantly smaller N400 in response to objects learned via translanguaging, as opposed to monolingually, thus suggesting easier processing of this information.

2.1.3 Research question 3 - *Since translanguaging involves simultaneous language and modality (i.e., going from comprehension to production) switch, what are the individual contributions of those components to the overall effect of translanguaging?*

Let’s first review the contributions of language-switching (Chapter 5). Participants in Chapter 4 showed an attenuated N400 to related, as opposed to unrelated, objects, which is in line with the extensive priming literature. They also had an attenuated N400 to objects learned through translanguaging, which does include language-switching. Therefore, the aim of the experiment in Chapter 5 was to establish whether those two effects (N400 modulated by relatedness and language-switching) will be similar in an experiment of bilingual processing of words but unlike in translanguaging, without the learning and modality-switch involved. As it was described before, the results were very different from those obtained in Chapter 4, and suggested more effortful processing of language-switch and no relatedness effect within the N400 window. This proves that translanguaging is, in fact, very different from ‘pure’ language-switching, and cannot be replaced with it and result in similar effects. This emphasises the fact that translanguaging is a purposeful, systematic and organised way of learning, and only by keeping those boundaries, the desired effects can be obtained.

Secondly, Chapter 6 examined modality-cross in Basque-Spanish bilinguals, performing the entire experiment in one language only (Spanish). The reason why bilingual individuals were asked to perform in only one, rather than two languages, was that we were aiming to answer one question first (naming by bilinguals), before moving on to the next (i.e., naming in two languages). Such step-by-step approach enables us to

disentangle any effects we find more easily, as they can be assigned to only one manipulation (modality-cross) rather than two (modality-cross and language-switch). Again, the main interest here was on the potential impact of going from comprehension to production on the N400, since this is where the original effects of translanguaging were found. We did find that the N400 was modulated by relatedness, very much like in the main translanguaging study (Chapter 4). We also found that it was modulated by modality, but only in word-blocks, such that production induced a significantly larger N400 than comprehension, suggesting more processing effort. There were earlier effects, within the N1 and P2 time windows, which showed clear differences between comprehension and production. The results showed that the waveforms of those two conditions start to diverge as early as 80 ms after the onset of a target – something that we have not found in Chapter 4. This, again, suggests that the impact of translanguaging cannot be reduced to simply comprehension-production switch, as on its own this manipulation produces very different results.

However, it is crucial to emphasise that the effects measured in Chapter 4 targeted medium- to long-term memory, and the manipulations of language- and modality-switch were done during learning, before the actual testing. Therefore, it is perhaps not that surprising that those effects were very different from those obtained in Chapters 5 and 6, which included online measures of processing.

2.1.4 Research question 4 - *Is translanguaging just a fancy word for code-switching?*

Based on the available literature and the results presented in this thesis, we can with some certainty, say that no, it is not. As explained above as well as in Chapter 5, language-switching on its own increased the processing effort, such that it resulted in a larger N400, compared to processing of same-language words. Therefore, this effect is exactly opposite to what we have found in Chapter 4, where translanguaging induced a smaller N400 thus suggesting less processing effort required. As mentioned before,

translanguaging is a purposeful learning strategy, which cannot be reduced to simply bilingual language mixing.

2.1.5 Research question 5 - *Are there any long-term implications of learning through translanguaging? Are they different from those based on monolingual learning?*

Again, yes and no. The long-term implications, as described above, have to be considered on two levels: behavioural and neural. On the behavioural level, long-term effects of translanguaging do not differ from those of monolingual learning, as both of those strategies produced comparable results at re-testing. At the neural level, however, the implications are very different. The ERP results clearly suggest that compared to what was learned monolingually, information acquired through translanguaging elicited a smaller N400, which we interpret as better integration of this knowledge and therefore less effortful processing. I believe that it really is the most remarkable that this effect has persisted over time, especially considering that participants had no opportunities to practice this knowledge in-between the testing sessions.

2.1.6 Research question 6 - *Finally, in qualitative and observational studies, translanguaging has been seen as a great strategy for learning. Will it be confirmed in carefully-designed, quantitative research?*

We have found some beneficial effects of learning through translanguaging over monolingual instruction at the neural level. Those results are very promising and pave way for future research into this subject. However, it is important to remember that there is still a long way to go before any definite claims about translanguaging described in qualitative and observational classroom research can be made. This is due to many reasons. Most importantly, there is a question to what extent the design of our study (Chapter 4) reflects ‘true’ translanguaging, as described by Cen Williams (1994a), Colin Baker (2002), and Ofelia García (2009, 2012). In our research, participants merely had to say a single word as the outcome of their learning. This is very different

from longer answers or explanations that students have to give in a real classroom, during real learning. As no other studies before measured the efficiency of translanguaging, it is difficult to predict whether the effects obtained in a more ‘real’ situation would be similar. Secondly, this thesis focused on the neural underpinnings of translanguaging, rather than the behavioural effects. It is clear that before making any strong claims about the efficiency of learning through translanguaging, it is essential to investigate it further with the aim of obtaining measurable, behavioural effects, because at the end of the day, this is what matters most in the educational setting. Finally, our study was done with early, native-like bilinguals, whereas all the previous observational reports have focused on learners of the second language. Again, because of the lack of quantitative studies on this topic, it is very difficult to predict whether similar effects would be obtained if we recruited unbalanced bilinguals, with different levels of proficiency. It is something that has to be investigated in the future, as translanguaging so far has been advocated as the best learning strategy for second-language learners, rather than early, balanced bilinguals.

3. Methodological considerations

Investigating bilingual people’s language processing is associated with a number of potential challenges, which could have had an impact on the results. Such possible limitations have to be kept in mind when drawing conclusions from this research.

3.1 Bilingual participants’ language skills

This is something of a concern in many, if not all the studies that investigate language processing in bilinguals. Firstly, the proficiency levels. Those differ across various studies that all have somewhat different language requirements and consider different issues to qualify someone as ‘proficient’. Here, I have attempted to overcome that by carefully choosing those participants, who have grown up with two languages, live and function every day in a bilingual community, use their two languages at home and at work or school, watch TV programmes in both languages, and so on. This, however, highlights the potential second problem, which concerns the self-reported language use questionnaires. It is easy for the participants to over- or under-estimate their actual

language use, either on purpose or not, meaning that they might wish to consciously alter the reality, or they might simply feel more emotional about one language but not the other, and this would affect their reported language use. This problem might be of a particular concern in Chapter 6, which looked at Basque-Spanish speakers, as the sense of ‘belonging’ is particularly strong in the areas they came from. Additionally, from the discussions with lab members over there, it was very clear that the ‘overestimation of Basque-ness’ is a common issue with those participants. Therefore, even though all formal assessments were checked, such as the examinations taken in their languages, there is no way to apply a stringent filter on participants’ self-reported use of everyday Basque and Spanish.

3.2 Behavioural effects (and the lack of thereof) in ERP studies

It is often the case, that ERP experiments are criticized for the lack of behavioural effects or when they are not in line with the ERP findings. The scepticism comes from the assumption that the lack of clear behavioural effects, in support of the ERP findings, questions the validity, and mainly reliability, of ERP results. In my view, such approach is flawed on a very general level. The main reason for it is that this criticism, by default, assumes that EEG as a technique does not bring anything new into the investigation, but rather acts as a ‘fancy’ and high-tech ‘back-up’ to the already obtained behavioural results. To the contrary, ERP evidence is relevant and informative in its own right and provides independent evidence for the question of interest and the phenomenon under study. It is crucial to remember that behavioural measures, such as reaction times, are offline measures, which are an outcome of a number of cognitive processes that take place from the time the stimulus appeared on the screen to when the participant had to make a conscious, overt response. Contrary to that, ERPs provide online, ongoing measure of brain activity and enable researchers to investigate what processes are involved in, and lead to, the behavioural effect. This is not to say that behavioural measures have to be in line with the results obtained through ERP analysis, or that even behavioural measures need to be collected in an ERP study. Indeed, in the present thesis, in Chapter 5, only ERPs were analysed, and no behavioural measurements were even collected to the critical stimuli. This was of course due to the nature and design of

the experiment, and I am not questioning that the research question of that study could potentially be answered in an experiment which combined ERPs with, let's say accuracy and reaction times, if one had the aim or the desire to do so. However, it was not a necessary approach in the case of my investigation and I believe that the design that I have used fully answered my research question with the use of ERPs only. Furthermore, the behavioural results of the translanguaging study (Chapter 4) are, in part, opposite to the ERP results, as they suggested more difficulties in the translanguaging, rather than monolingual learning, whereas the ERP results clearly showed less effort when processing objects learned through translanguaging.

Indeed, ERPs can index a number of cognitive processes that might, but also might not, affect later/upcoming behavioural measures, such as reaction times. There are a number of cognitive processes that do not result in easily measureable behavioural outcomes. Additionally, it might be difficult to quantify what the behavioural outcome was a response to, since processes unfold over time (from stimulus presentation to, let's say, a button press) and there might be different in-between stages of processing which button presses as the end result cannot measure.

4. Practical implications and limitations

There is no question that any research that brings together education and neuroscience has a potential to make an impact on the world around us. Translanguaging has already become a key approach to bilingual education in many parts of the world, despite the lack of any quantitative work that would confirm its effectiveness. It is also clear that the research presented in this thesis has merely opened a gate to future investigations, which are essential before any conclusive directions for education can be made. However, in principle, if translanguaging was confirmed to be the best way to educate bilingual children, it would have significant impact on policy making across the globe, but especially in countries such as Wales, with more than one official language.

Of course, if successful, this would have its limitations, too. Firstly, the financial impact of potentially changing educational policies, which would come at a high cost for local offices. Secondly, providing appropriate training for teachers, who would all need to be bilingual and willing to work within such educational setting. Finally, as all children are different, and all societies vary in how they educate and approach bilingualism, adopting a ‘one size fits all’ philosophy might not be the best idea. Translanguaging might work well within one community, but not the other, and much research has to be done before we can confidently say that we have found out the best way to educate bilingual children.

5. Ideas for future research

This research has opened up an avenue to investigations concerning what stands behind the success of translanguaging so far. Without a doubt, more research is needed. Firstly, the most urgent issue seems to be researching a ‘fuller’ version of translanguaging, meaning one, in which the output of participants’ learning is not restricted to single words. Such extended answers would provide a more realistic window into how translanguaging might work in real life and classroom situations. Furthermore, research with bilingual individuals with different levels of L2 proficiency is also essential, in order to match classroom situations, which so far have been described in the observational reports of translanguaging. Also, investigations of different age groups are needed, especially since translanguaging is most commonly used with school-aged children.

In terms of what is behind the success of translanguaging, more research on the individual components is needed. Firstly, a study involving modality-cross and language-switching, similar to the one presented in Chapter 6 but with an added language-switching component. Secondly, language-switching and modality-switching should be tested in a design, which aims to test medium- to long-term memory effects (as in the main translanguaging study in Chapter 4), rather than immediate impact of those manipulations of the ERP modulations. Finally, those components should also be

individually tested in children, as well as individuals with different proficiency levels of their L2.

6. Concluding remarks

- 6.1** Translanguaging is a teaching and learning strategy in which bilinguals receive information in one language and produce it back in another. In this thesis, I have shown that learning through translanguaging has a significant impact on the semantic integration, as indexed by the N400, such that the waveform is attenuated to information acquired through translanguaging, as opposed to monolingually. This effect is interpreted in terms of processing load or effort needed to integrate the information, with more effortless processing associated with information learned through translanguaging.
- 6.2** This effect is long lasting, and was found to be significant in the same group of participants when tested a few weeks after the initial experimental sessions, without any warning or preparation.
- 6.3** It is argued that translanguaging is an organised, purposeful strategy, which includes simultaneous language- and modality-switch. However, its effectiveness cannot be reduced to merely those two components, as when tested individually, they do not produce similar results to those of translanguaging.
- 6.4** This thesis has taken the first, small step towards understanding something as complex as the neural bases of bilingual education, in order to establish whether translanguaging indeed provides the best way to educate bilingual children globally. Although the results presented here are very promising, much more research has to be done on this topic before making final conclusions and recommendations.
- 6.5** For now, however, what is clear from this work, is that using two languages in the same context during learning, as in translanguaging, is not detrimental and might, in fact, be beneficial for students.

References

- Alvarez, R., Holcomb, P., & Grainger, J. (2003). Accessing word meaning in two languages: An event-related brain potential study of beginning bilinguals. *Brain and Language*, 87, 290-304.
- Aparicio, X., Midgley, K., Holcomb, P., Pu, H., Lavaur, J-M., & Grainger, J. (2012). Language effects in trilinguals: An ERP study. *Frontiers in Psychology*, 3: 402, 1-9.
- Baker, C. (1993). Bilingual Education in Wales. In H. Beardsmore (Ed.), *European Models of Bilingual Education (7-29)*. Clevedon, UK: Multilingual Matters.
- Baker, C. (2003). Biliteracy and Transliteracy in Wales: Language Planning and the Welsh National Curriculum. In N. Hornberger (Ed.), *Continua of Biliteracy: An Ecological Framework for Educational Policy, Research, and Practice in Multilingual Settings (71-90)*. Clevedon, UK: Multilingual Matters.
- Baker, C. (2006). *Foundations of Bilingual Education and Bilingualism*. Multilingual Matters, Clevedon.
- Barrett, S., & Rugg, M. (1989). Event-related potentials and the semantic matching of faces. *Neuropsychologia*, 27, 913-922.
- Bentin, S., Kutas, M., & Hillyard, S. (1993). Electrophysiological evidence for task effects on semantic priming in auditory word processing. *Psychophysiology*, 30, 161-169.
- Beres, A. M. (2014). Translanguaging: A Road to Bilingually Boosted Education. Poster presented at the 9th Annual Alpine Brain Imaging Meeting, Champéry, Switzerland, 14th January 2014.

- Besson, M., & Macar, F. (1987). An event-related potential analysis of incongruity in music and other non-linguistic contexts. *Psychophysiology*, *24*, 14-25.
- Blackford, T., Holcomb, P., Grainger, J., & Kuperberg, G. (2012). A funny thing happened on the way of articulation: N400 attenuation despite behavioral interference in picture naming. *Cognition*, *123*, 84-99.
- Blackledge, A., & Creese, A. (2010). *Multilingualism: A Critical Perspective*. London, UK: Continuum.
- Bodner, G., & Masson, M. (2003). Beyond spreading activation: An influence of relatedness proportion on masked semantic priming. *Psychonomic Bulletin & Review*, *10*, 645-652.
- Bosch, L., Costa, A., & Sebastian-Gallés, N. (2000). First and second language vowel perception in early bilinguals. *European Journal of Cognitive Psychology*, *12*, 189-222.
- Bourassa, D., & Besner, D. (1998). When do nonwords activate semantics? Implications for models of visual word recognition. *Memory & Cognition*, *26*, 61-74.
- Bronzino, J. D. (1995). Principles of electroencephalography. In J. D. Bronzino (Ed.), *The Biomedical Engineering Handbook* (201-212). Florida: CRC Press.
- Brysbaert, M. (2003). Bilingual visual word recognition: Evidence from masked phonological priming. In S. Kinoshita & S. Lupker (Eds.), *Masked priming: the state of the art* (323-343). Hove, U.K.: Psychology Press.

- Canagarajah, S. (2011). Codemeshing in Academic Writing: Identifying Teachable Strategies of Translanguaging. *Modern Language Journal*, 95, 401-417.
- Cenoz, J., & Gorter, D. (2011). A Holistic Approach to Multilingual Education: Introduction. *The Modern Language Journal*, 95, 339-343.
- Chauncey, K., Grainger, J., Holcomb, P. (2008). Code-switching effects in bilingual word recognition: A masked priming study with event-related potentials. *Brain and Language*, 105, 161-174.
- Chauncey, K., Holcomb, P., & Grainger, J. (2009). Primed picture naming within and across languages: An ERP investigation. *Cognitive, Affective, & Behavioral Neuroscience*, 9, 286-303.
- Chauncey, K., Grainger, J., Holcomb, P. (2011). The role of subjective frequency in language switching: An ERP investigation using masked priming. *Memory and Cognition*, 39, 291-303.
- Cheour, M., Ceponiene, R., Lehtokoski, A., Luuk, A., Allik, J., Alho, K., & Näätänen, R. (1998). Development of language-specific phoneme representations in the infant brain. *Nature Neuroscience*, 1, 351-53.
- Clifton, C., Meyer, A., Wurm, L., & Treiman, R. (2013). Language comprehension and production. In A. F. Healy & R. W. Proctor (Eds.) *Comprehensive handbook of psychology (second edition). Volume 4: Experimental Psychology* (523-47). New York: Wiley.
- Coltheart, M. (1981). The MRC psycholinguistic database. *Quarterly journal of experimental psychology*, 33, 497-505.

- Cook, V. (2001). Using the First Language in the Classroom. *Canadian Modern Language Review*, 57, 402-423.
- Cook, V. (2007). The Goals of ELT: Reproducing Native Speakers or Promoting Multi-Competence among Second Language Users? In J. Cummins & C. Davison (Eds.), *International Handbook of English Language Teaching* (237-248). New York: Springer.
- Costa, A., Strijkers, K., Martin, C., & Thierry, G. (2009). The time course of word retrieval revealed by event-related brain potentials during overt speech. *Proceedings of the National Academy of Sciences*, 106, 21442-46.
- Coulson, S., King, J., & Kutas, M. (1998). Expect the unexpected: Event-related brain response to morphosyntactic violations. *Language and Cognitive Processes*, 13, 21-58.
- Crawford, J. (2007). The Decline of Bilingual Education in the USA: How to Reverse a Troubling Trend? *International Multilingual Research Journal*, 1, 33-37.
- Creese, A., & Blackledge, A. (2010). Translanguaging in the Bilingual Classroom: A Pedagogy for Learning and Teaching? *The Modern Language Journal*, 94, 103-115.
- Creese, A., & Blackledge, A. (2011). Separate and Flexible Bilingualism in Complementary Schools: Multiple Language Practices in Interrelationship. *Journal of Pragmatics*, 43, 1196-1208.
- Cummins, J. (2000). *Language, Power, and Pedagogy: Bilingual Children in the Crossfire*. Clevedon, UK: Multilingual Matters.

- Dalrymple-Alford, E. (1985). Language switching during bilingual reading. *British Journal of Psychology*, 76, 111-122.
- de Groot, A., & Nas, G. (1991). Lexical representation of cognates and noncognates in compound bilinguals. *Journal of Memory and Language*, 30, 90-123.
- Debrulle, J., Pineda, J., & Renault, B. (1996). N400-like potentials elicited by faces and knowledge inhibition. *Cognitive Brain Research*, 4, 133-144.
- Dell, G., Schwartz, M., Martin, N., Saffran, E., & Gagnon, D. (1997). Lexical access in aphasic and nonaphasic speakers. *Psychological Review*, 104, 801-838.
- Deutsch, A., & Bentin, S. (2001). Syntactic and semantic factors in processing gender agreement in Hebrew: evidence from ERPs and eye movements. *Journal of Memory and Language*, 45, 200-24.
- Devlin, J., Jamison, H., Matthews, P., & Gonnerman, L. (2004). Morphology and the internal structure of words. *Proceedings of the National Academy of Sciences*, 101, 14687-14688.
- Dijkstra, A., & van Heuven, W. (1998). The BIA-model and bilingual word recognition. In J. Grainger & A. Jacobs (Eds.), *Localist connectionist approaches to human cognition* (189-225). Mahwah, NJ: Erlbaum.
- Dijkstra, A., & van Heuven, W. (2002). The architecture of the bilingual word recognition system: From identification to decision. *Bilingualism, Language and Cognition*, 5, 175-197.
- Edwards, J. (2003). The Importance of Being Bilingual. In J-M. Dewaele, A. Housen, & Li Wei (Eds.) *Bilingualism: Beyond Basic Principles* (28-42). Clevedon, UK: Multilingual Matters.

Ellis, N. C., O'Dochartaigh, C., Hicks, W., Morgan, M., & Laporte, N. (2001). Cronfa Electroneg o Gymraeg (CEG): A 1 million word lexical database and frequency count for Welsh. [On-line]. Available at www.bangor.ac.uk/canolfanbedwyr/ceg.php.en

Esquinca, A. (2011). Bilingual College Writers' Collaborative Writing of Word Problems. *Linguistics and Education, 22*, 150-167.

Finkbeiner, M., Forster, K., Nicol, J., & Nakumura, K. (2004). The role of polysemy in masked semantic and translation priming. *Journal of Memory and Language, 51*, 1-22.

Fischler, I., & Goodman, G. (1978). Latency of associative activation in memory. *Journal of Experimental Psychology: Human Perception and Performance, 4*, 455-470.

Friederici, A., Pfeifer, E., & Hahne, A. (1993). Event-related brain potentials during natural speech processing – effects of semantic, morphological and syntactic violations. *Cognitive Brain Research, 1*, 183-92.

Friederici, A., Hahne, A., & Saddy, D. (2002). Distinct neurophysiological patterns reflecting aspects of syntactic complexity and syntactic repair. *Journal of Psycholinguistic Research, 31*, 45-63.

Friedrich, C., Eulitz, C., & Lahiri, A. (2006). Not every pseudoword disrupts word recognition. An ERP study. *Behavioural and Brain Functions, 2*, 36-46.

Fuentes, L., Carmona, E., Agis, I., & Catena, A. (1994). The role of the anterior attention system in semantic processing of both foveal and parafoveal words. *Journal of Cognitive Neuroscience, 6*, 17-25.

- Gaillard, R., del Cul, A., Naccache, L., Vinckier, F., Cohen, L., & Dehaene, S. (2006). Nonconscious semantic processing of emotional words modulates conscious access. *Proceedings of the National Academy of the USA*, 103, 7524-7529.
- Galvez, L. (2013). The No Child Left Behind Act Leaves Behind ESL Children. <http://www.luc.edu/media/lucedu/law/centers/childlaw/childed/pdfs/2013studentpapers/galvez.pdf> Accessed 04th December 2014.
- García, O. (2006). Foreword: Inventing Discourses, Representations and Conceptualizations of Language. In S. Makoni & A. Pennycook (Eds.), *Disinventing and Reconstituting Languages*, (xi-xv). Clevedon, UK: Multilingual Matters.
- García, O. (2009). *Bilingual Education in the 21st century: A Global Perspective*. Malden, MA: Blackwell.
- García, O. (2011). From Language Garden to Sustainable Languaging: Bilingual Education in a Global World. *Perspective. A publication of the National Association for Bilingual Education, Sept/Oct 2011*, 5-10.
- García, O. (2012). Theorizing Translanguaging for Educators. In C. Celic & K. Seltzer (Eds.), *Translanguaging: A CUNY-NYSIEB Guide for Educators* (1-6). <http://www.nysieb.ws.gc.cuny.edu/files/2012/06/FINAL-Translanguaging-Guide-With-Cover-1.pdf> Accessed 19th November 2014.
- García, O. (2013a). From Diglossia to Transglossia: Bilingual and Multilingual Classrooms in the 21st century. Building on Experience. In C. Abello-Contesse, P. Chandler, M. López-Jiménez, & R. Chacón-Beltrán (Eds.), *Bilingual and Multilingual Education in the 21st Century*, (155-175). Bristol, UK: Multilingual Matters.

<http://ofeliagarciadotorg.files.wordpress.com/2014/01/from-disglossia-to-transglossia.pdf> Accessed 09th August 2014.

García, O. (2013b). *Translanguaging to Teach English in Nepal*.

<http://neltachoutari.wordpress.com/2013/07/01/translanguaging-to-teach-english-in-nepal/> Accessed 04th September 2014.

García, O. (2013c). Theorizing and Enacting Translanguaging for Social Justice. In A. Blackledge & A. Creese (Eds.), *Heteroglossia as Practice and Pedagogy* (199–216). New York: Springer.

García, O. (2014a). Countering the Dual: Transglossia, Dynamic Bilingualism and Translanguaging in Education. In R. Rubdy & L. Alsagoff (Eds.), *The Global-Local Interface, Language Choice and Hybridity* (100-118). Bristol, UK: Multilingual Matters.

García, O. (2014b). Becoming Bilingual and Biliterate: Sociolinguistic and Sociopolitical Considerations. In A. Stone, E. Silliman, B. Ehren, & G. Wallach (Eds.), *Handbook of Language and Literacy: Development and Disorders* (145-160). New York: The Guilford Press.

García, O. (2014c). Multilingualism and Language Education. In C. Leung & B. Street (Eds.), *The Routledge Companion to English Studies* (84-99). New York: Routledge.

García, O., & Sylvan, C. (2011). Pedagogies and Practices in Multilingual Classrooms: Singularities in Pluralities. *The Modern Language Journal*, 95, 385-400.

García, O., Homonoff Woodley, H., Flores, N., & Chu, H. (2012). Latino Emergent Bilingual Youth in High Schools: Transcaring Strategies for Academic Success. *Urban Education*, 48, 798-827.

- García, O. & Li Wei. (2014). *Translanguaging: Language, Bilingualism and Education*. Basingstoke: Palgrave Macmillan.
- Garrod, S., & Pickering, M. (2004). Why is conversation so easy? *Trends in Cognitive Sciences*, 8, 8-11.
- Gold, B., & Rastle, K. (2007). Neural correlates of morphological decomposition during visual word recognition. *Journal of Cognitive Neuroscience*, 19, 1983-1993.
- Gollan, T., Forster, K., & Frost, R. (1997). Translation priming with different scripts: Masked priming with cognates and noncognates in Hebrew-English bilinguals. *Journal of Experimental Psychology: Learning, Memory, and Cognition*, 23, 1122-1139.
- Gratton, G., Coles, M., & Donchin, E. (1983). A new method for off-line removal of ocular artifact. *Electroencephalography and clinical neurophysiology*, 55, 468-84.
- Grainger, J., & Beauvillain, C. (1987). Language blocking and lexical access in bilinguals. *Quarterly Journal of Experimental Psychology: Human Experimental Psychology*, 39A, 295-319.
- Grainger, J., & Dijkstra, T. (1992). On the representation and use of language information in bilinguals. In R. Harris (Ed.), *Cognitive processing in bilinguals* (207-220). Amsterdam: Elsevier Science Publishers.
- Green, D. (1992). Mental control of the bilingual lexico-semantic system. *Bilingualism: Language and Cognition*, 1, 67-81.

- Grosjean, F. (1989). Neurolinguists, Beware! The Bilingual is Not Two Monolinguals in One Person. *Brain and Language*, 36, 3-15.
- Grosjean, F. (2010). *Bilingual: Life and Reality*. Cambridge, MA: Harvard University Press.
- Grossi, G. (2006). Relatedness proportion effects on masked associative priming: an ERP study. *Psychophysiology*, 43, 21-30.
- Guasch, M., Sánchez-Casas, R., Ferré, P., & García-Albea, J. (2011). Effects of the degree of meaning similarity on cross-language semantic priming in highly proficient bilinguals. *Journal of Cognitive Psychology*, 23, 942-961.
- Hagoort, P., Brown, C., & Groothusen, J. (1993). The syntactic positive shift (SPS) as an ERP measure of syntactic processing. *Language and Cognitive Processes*, 8, 439-83.
- Hagoort, P., Wassenaar, M., & Brown, C. (2003). Syntax-related ERP-effects in Dutch. *Cognitive Brain Research*, 16, 38-50.
- Herculano-Houzel, S. (2009). The human brain in numbers: a linearly scaled-up primate brain. *Frontiers in Human Neuroscience*, 3:31, 1-11.
- Holcomb, P., & Anderson, J. (1993). Cross-modal semantic priming: A time-course analysis using event-related brain potentials. *Language and Cognitive Processes*, 8, 379-411.
- Holcomb, P., Grainger, J., & O'Rourke, T. (2002). An electrophysiological study of the effects of orthographic neighbourhood size on printed word perception. *Journal of Cognitive Neuroscience*, 14, 938-950.

- Hornberger, N. & Link, H. (2012). Translanguaging and Transnational Literacies in Multilingual Classrooms: A Biliteracy Lens. *International Journal of Bilingual Education and Bilingualism*, 15, 261-278.
- Indefrey, P., & Levelt, W. (2004). The spatial and temporal signatures of word production components. *Cognition*, 92, 101-144.
- Jacobson, R. & Faltis, C. (1990). *Language Distribution Issues in Bilingual Schooling*. Clevedon, UK: Multilingual Matters.
- Jasper, H. (1958). Report of the committee on methods of clinical examination in electroencephalography: 1957. *Electroencephalography and Clinical Neurophysiology*, 10, 370-375.
- Jescheniak, J., Schriefers, H., Garrett, M., & Friederici, A. (2002). Exploring the activation of semantic and phonological codes during speech planning with event-related brain potentials. *Journal of Cognitive Neuroscience*, 14, 951-964.
- Jones, G. (1982). *Controls and Conflicts in Welsh Secondary Education 1889-1944*. Cardiff: University of Wales Press.
- Kaan, E., Harris, A., Gibson, E., & Holcomb, P. (2000). The P600 as an index of syntactic integration difficulty. *Language & Cognitive Processes*, 15, 159-201.
- Kaan, E., & Swaab, T. (2003). Electrophysiological evidence for serial sentence processing: a comparison between non-preferred and ungrammatical continuations. *Cognitive Brain Research*, 17, 621-35.
- Kaan, E., Dallas, A., Barkley, C. (2006). Processing bare quantifiers in discourse. *Brain Research*, 1146, 199-209.

- Kaan, E. (2007). Event-Related Potentials and Language Processing: A Brief Overview. *Language and Linguistics Compass*, 1, 571-591.
- Kano, N. (2013). Translanguaging as a Process and a Pedagogical Tool for Japanese Students in an English Writing Course in New York. *Dissertation Abstracts International Section A: Humanities and Social Sciences*, 74(10-A(E)). ProQuest Information & Learning, 2013. AAI3512508.
- Kerkhofs, R., Dijkstra, T., Chwilla, D., & de Bruijn, E. (2006). Testing a model for bilingual semantic priming with interlingual homographs: RT and N 400 effects. *Brain Research*, 1068, 170-183.
- Kiefer, M., & Brendel, D. (2006). Attentional modulation of unconscious automatic processes: evidence from event-related potentials in a masked priming paradigm. *Journal of Cognitive Neuroscience*, 18, 184-198.
- Kluender, R., & Kutas, M. (1993a). Subjacency as a processing phenomenon. *Language and Cognitive Processes*, 8, 573-633.
- Kluender, R., & Kutas, M. (1993b). Bridging the gap: evidence from ERPs on the processing of unbounded dependencies. *Journal of Cognitive Neuroscience*, 5, 196-214.
- Koester, D., & Schiller, N. (2008). Morphological priming in overt language production: Electrophysiological evidence from Dutch. *NeuroImage*, 42, 1622-1630.
- Kotz, S., & Elston-Güttler, K. (2004). The role of proficiency on processing categorical and associative information in the L2: Reaction times and event-related potentials. *Journal of Neurolinguistics*, 17, 215-235.

- Kouider, S., Dehaene, S., Jobert, A., & Le Bihan, D. (2007). Cerebral bases of subliminal and supraliminal priming during reading. *Cerebral Cortex*, *17*, 2019-2029.
- Kroll, J., & Stewart, E. (1994). Category interference in translation and picture naming: Evidence for asymmetric connections between bilingual memory representations. *Journal of Memory and Language*, *33*, 149-174.
- Kroll, J., & Tokowicz, N. (2001). The development of conceptual representation for words in a second language. In J. Nicol (Ed.), *One mind, two languages: Bilingual language processing* (47-71). Malden, MA: Blackwell Publishers.
- Kroll, J., & Sunderman, G. (2003). Cognitive processes in second language acquisition: The development of lexical and conceptual representations. In C. Doughty & M. Long (Eds.), *Handbook of second language acquisition* (104-129). Cambridge, MA: Blackwell Publishers.
- Kroll, J., & Tokowicz, N. (2005). Models of bilingual representation and processing: Looking back and to the future. In J. Kroll & A. de Groot (Eds.), *Handbook of bilingualism: Psycholinguistic approaches* (531-553). New York: Oxford University Press.
- Kutas, M., & Hillyard, A. (1980). Reading senseless sentences: Brain potentials reflect semantic incongruity. *Science*, *207*, 203-05.
- Kutas, M., & Hillyard, A. (1983). Event-related brain potentials to grammatical errors and semantic anomalies. *Memory and Cognition*, *11*, 539-50.
- Kutas, M., Neville, H., & Holcomb, P. (1987). A preliminary comparison of the N400 response to semantic anomalies during reading, listening and signing. *Electroencephalography and clinical neurophysiology. Supplement*, *39*, 325-30.

- Kutas, M., & Iragui, V. (1998). The N400 in a semantic categorization task across 6 decades. *Electroencephalography and Clinical Neurophysiology/Evoked potentials section*, *108*, 456-471.
- Kutas, M., & Federmeier, K. (2011). Thirty years and counting: Finding meaning in the N400 component of the event related brain potential (ERP). *Annual Review of Psychology*, *62*, 621-647.
- Laganaro, M., Morand, M., Schwitter, V., Zimmermann, C., Camen, C., & Schnider, A. (2009). Electrophysiological correlates of different anommic patterns in comparison with normal word production. *Cortex*, *45*, 697-707.
- Leinonen, A., Grönholm-Nyman, P., Järvenpää., M., Söderholm, C., Lappi, O., Laine, M., & Krause, C. (2009). Neurocognitive processing of auditorily and visually presented inflected words and pseudowords: evidence from a morphologically rich language. *Brain Research*, *1275*, 56-66.
- Lelekov, T., Dominey, P., & Garcia-Larrea, L. (2000). Dissociable ERP profiles for processing rules vs. instances in a cognitive sequencing task. *Neuroreport: For Rapid Communication of Neuroscience Research*, *11*, 1129-32.
- Levelt, W., Roelofs, A., & Meyer, A. (1999). A theory of lexical access in speech production. *Behavioral and Brain Sciences*, *22*, 1-38
- Lewis, E. (1977). Bilingualism and Bilingual education – the ancient world to the Renaissance. In B. Spolsky & R. Cooper (Eds.), *Frontiers of Bilingual Education*. Rowley, MA: Newbury House.

- Lewis, G., Jones, B., & Baker, C. (2012). Translanguaging: developing its conceptualisation and contextualisation. *Educational Research and Evaluation: An International Journal on Theory and Practice*, 18, 655-670.
- Li Wei. (2011). Moment Analysis and Translanguaging Space: Discursive Construction of Identities by Multilingual Chinese Youth in Britain. *Journal of Pragmatics*, 43, 1222-1235.
- Li Wei. (2014). Negotiating Funds of Knowledge and Symbolic Competence in the Complementary School Classrooms. *Language and Education*, 28, 161-180.
- Lin, A., & Martin, P. (Eds.) (2005). *Decolonisation, Globalisation. Language in Education Policy and Practice*. Clevedon: Multilingual Matters.
- Lopes da Silva, F. (2010). EEG: Origin and Measurement. In C. Mulert & L. Lemieux (Eds.) *EEG-fMRI: Physiological basis, technique, and applications* (19-38). London: Springer.
- Lopez-Calderon, J., & Luck, S. (2014). ERPLAB: an open-source toolbox for the analysis of event-related potentials. *Frontiers in Human Neuroscience*, 8, 213-27.
- Luck, S., Woodman, G., & Vogel, E. (2000). Event-related potential studies of attention. *Trends in Cognitive Sciences*, 4, 432-440.
- Luck, S. (2005). *An Introduction to the event-related potential technique*. Cambridge, Massachusetts: MIT Press
- Mackey, W. (1978). The importation of bilingual education models. In J. Altis (Ed.), *Georgetown University Round Table on Languages and Linguistics* (1- 18). Washington, DC: Georgetown University Press.

- Maess, B., Friederici, A., Damian, A., Meyer, A., & Levelt, W. (2002). Semantic category interference in overt picture naming: Sharpening current density localization by PCA. *Journal of Cognitive Neuroscience, 14*, 455-462.
- Mahon, B., Costa, A., Peterson, R., Vargas, K., & Caramazza, A. (2007). Lexical selection is not by competition: A reinterpretation of semantic interference and facilitation effects in the picture-word interference paradigm. *Journal of Experimental Psychology: Memory & Cognition, 33*, 503-535.
- Mahon, B., & Caramazza, A. (2009). Concepts and Categories: A Cognitive Neuropsychological Perspective. *Annual Review of Psychology, 60*, 27-51.
- Malerich, J. (2008). Welsh Language & Education: A History & Future. *EDGI 510: Culture, Society & Education*
http://www.jennifermalerich.com/uploads/Welsh_Language-a_History_Future.pdf Accessed 7th November 2012.
- Marí-Beffa, P., Houghton, G., Estévez, A., & Fuentes, L. (2000). Word-based grouping affects the prime-task effect on semantic priming. *Journal of Experimental Psychology: Human Perception and Performance, 26*, 469-79.
- Martin, C., Dering, B., Thomas, E., & Thierry, G. (2009). Brain potentials reveal semantic priming in both 'active' and the 'non-attended' language of early bilinguals. *NeuroImage, 47*, 326-333.
- McLaughlin, B. (1978). *Second-language Acquisition in Childhood*. Hillsdale, N. J.: Erlbaum.

- McNamara, T. & Holbrook, J. (2003). Semantic memory and priming. In A. F. Healy & R. W. Proctor (Eds.) *Comprehensive handbook of psychology (second edition). Volume 4: Experimental Psychology* (447-474). New York: Wiley.
- McPherson, W., & Holcomb, P. (1999). An electrophysiological investigation of semantic priming with pictures of real objects. *Psychophysiology*, *36*, 53-63.
- Menken, K. (2006). Teaching to the Test: How No Child Left Behind Impacts Language Policy, Curriculum, and Instruction for English Language Learners. *Bilingual Research Journal*, *30*, 521-547.
- Menken, K. & Solorza, C. (2014). No Child Left Bilingual: Accountability and the Elimination of Bilingual Education Programs in New York City Schools. *Educational Policy*, *28*, 96-125.
- Meuter, R., & Allport, A. (1999). Bilingual language switching in naming: Asymmetrical costs of language selection. *Journal of Memory and Language*, *40*, 25-40.
- Moll, L. & Diaz, S. (1985). Ethnographic Pedagogy: Promoting Effective Bilingual Instruction. In E. García & R. Padilla (Eds.), *Advances in Bilingual Education Research* (127-149). Tucson, AZ: University of Arizona Press.
- Näätänen, R. (2003). Mismatch negativity: clinical research and possible applications. *International Journal of Psychophysiology*, *48*, 179-188.
- Naccache, L., Gaillard, R., Adam, C., Hasboun, D., Clemenceau, S., Baulac, M., Dehaene, S., & Cohen, N. (2005). A direct intracranial record of emotions evoked by subliminal words. *Proceedings of the National Academy of the USA*, *102*, 7713-7717.

- Nigam, A., Hoffman, J., & Simons, R. (1992). N400 to semantically anomalous pictures and words. *Journal of Cognitive Neuroscience*, 4, 15-22.
- Núñez-Pena, I., & Honrubia-Serrano, M. (2004). P600 related to rule violation in an arithmetic task. *Cognitive Brain Research*, 18, 130-41.
- Nunez, P., Silberstein, R., Cadusch, P., & Wijesinghe, R. (1993). Comparison of high resolution EEG methods having different theoretical bases. *Brain Topography*, 5, 361-364.
- Oldfield, R. (1971). The assessment and analysis of handedness: The Edinburgh inventory. *Neuropsychologia*, 9, 97-113.
- Osterhout, L., & Holcomb, P. (1992). Event-related brain potentials elicited by syntactic anomaly. *Journal of Memory and Language*, 31, 785-806.
- Osterhout, L., Holcomb, P., & Swinney, D. (1994). Brain potentials elicited by garden-path sentences: evidence of the application of verb information during parsing. *Journal of Experimental Psychology: Learning, Memory, and Cognition*, 20, 786-803.
- Osterhout, L., & Mobley, L. (1995). Event-related brain potentials elicited by failure to agree. *Journal of Memory and Language*, 34, 739-773.
- Otsuji, E. & Pennycook, A. (2010). Metrolingualism: Fixity, Fluidity and Language in Flux. *International Journal of Multilingualism*, 7, 240-254.
- Park, Mi Sun. (2013). Code-switching and Translanguaging: Potential Functions in Multilingual Classrooms. *Teachers College, Columbia University Working Papers in TESOL & Applied Linguistics*, 13, 50-52.

<http://journals.tc-library.org/index.php/tesol/article/viewFile/960/603> Accessed 9th December 2014.

- Patel, A., Gibson, E., Ratner, J., Besson, M., & Holcomb, P. (1998). Processing syntactic relations in language and music: and event-related potential study. *Journal of Cognitive Neuroscience*, *10*, 717-33.
- Perea, M., & Gotor, A. (1997). Associative and semantic priming effects occur at very short SOAs in lexical decision and naming. *Cognition*, *67*, 223-240.
- Perea, M., & Rosa, E. (2002). Does the proportion of associatively related pairs modulate the associative priming effect at very brief stimulus-onset asynchronies? *Acta Psychologica*, *110*, 103-124.
- Perea, M., & Lupker, S. (2003). Does judge activate COURT? Transposed-letter similarity effects in masked associative priming. *Memory & Cognition*, *31*, 829-841.
- Perea, M., Urkia, M., Davis, C., Agirre, A., Laseka, E., & Carreiras, M. (2006). E-Hitz: A word-frequency list and a program for deriving psycholinguistic statistics in an agglutinative language (Basque). *Behavior Research Methods*, *38*, 610-615.
- Perea, M., Duñabeitia, J.A., & Carreiras, M. (2008). Masked associative/semantic priming effects across languages with highly proficient bilinguals. *Journal of Memory and Language*, *58*, 916-930.
- Pickering, M., & Garrod, S. (2007). Do people use language production to make predictions during comprehension? *Trends in Cognitive Sciences*, *11*, 105-110.
- Pickering, M., & Garrod, S. (2013a). An integrated theory of language production and comprehension. *Behavioral and Brain Sciences*, *36*, 329-347.

- Pickering, M., & Garrod, S. (2013b). How tightly are production and comprehension interwoven? *Frontiers in Psychology*, 4:238, 1-2.
- Potter, M. & Faulconer, B. (1975). Time to understand pictures and words. *Nature*, 253, 437-438.
- Potter, M., Kroll, J., Yachzel, B., Carpenter, E., & Sherman, J. (1986). Pictures in sentences: understanding without words. *Journal of Experimental Psychology: General*, 115, 281-294.
- Rahman, R., & Melinger, A. (2009). Semantic context effects in language production: A swinging lexical network proposal and a review. *Language and Cognitive Processes*, 24, 713-734.
- Reyes, L. (2006). The Aspira Consent Decree: A thirtieth anniversary retrospective of bilingual education in New York City. *Harvard Education Review*, 76, 369-400.
- Riès, S., Legou, T., Burle, B., Alario, F., & Malfait, N. (2012). Why does picture naming take longer than word reading? The contribution of articulatory processes. *Psychonomic bulletin & review*, 19, 955-61.
- Rodriguez-Fornells, A., Schmitt, B., Kutas, M., & Munte, T. (2002). Electrophysiological estimates of the time course of semantic and phonological encoding during listening and naming. *Neuropsychologia*, 40, 778-787.
- Roelofs, A. (1997). The WEAVER model of word-form encoding in speech production. *Cognition*, 64, 249-284.
- Roelofs, A. (2008). Attention to spoken word planning: chronometric and neuroimaging evidence. *Language and Linguistics Compass*, 2, 389-405.

- Sánchez-Casas, R., Davis, C., & García-Albea, J. (1992). Bilingual lexical processing: Exploring the cognate/non-cognate distinction. *European Journal of Cognitive Psychology, 4*, 293-310.
- Saunders, G. (1988). *Bilingual Children: From Birth to Teens*. Clevedon, UK: Multilingual Matters.
- Schmitt, B., Munte, T., & Kutas, M. (2000). Electrophysiological estimates of the time course of semantic and phonological encoding during implicit picture naming. *Psychophysiology, 37*, 473-484.
- Schriefers, H., Meyer, A., & Levelt, W. (1990). Exploring the time course of lexical access in language production: Picture-word interference studies. *Journal of Memory and Language, 29*, 86-102.
- Sereno, S., & Rayner, K. (1992). Fast priming during eye fixations in reading. *Journal of Experimental Psychology: Human perception and performance, 18*, 173-184.
- Silverberg, S., & Samuel, A. (2004). The effect of age of second language acquisition on the representation and processing of second language words. *Journal of Memory and Language, 51*, 381-398.
- Snodgrass, J. G., & Vanderwart, M. (1980) A standardized set of 260 pictures: Norms for name agreement, image agreement, familiarity, and visual complexity. *Journal of Experimental Psychology: Human Learning & Memory, 6*, 174-215.
- Soares, C., & Grosjean, F. (1984). Bilinguals in a monolingual and a bilingual speech mode: The effect of lexical access. *Memory and Cognition, 12*, 380-386.

- Strijkers, K., Costa, A., & Thierry, G. (2010). Tracking lexical access in speech production: electrophysiological correlated of word frequency and cognate effects. *Cerebral Cortex*, *20*, 912-28.
- Strijkers, K., & Costa, A. (2011). Riding the lexical speedway: a critical review on the time course of lexical selection in speech production. *Frontiers in Psychology*, *2*, 365-72.
- Teplan, M. (2002). Fundamentals of EEG Measurement. *Measurement Science Review*, *2*, 1-11.
- Thomas, M., & Allport, A. (2000). Language switching costs in bilingual visual word recognition. *Journal of Memory and Language*, *43*, 44-66.
- Valdes, G. (2005). Bilingualism, Heritage Language Learners, and SLA Research: Opportunities Lost or Seized? *Modern Language Journal*, *89*, 410-434.
- Valdés, B., Catena, A., & Marí-Beffa, P. (2005). Automatic and controlled semantic processing: A masked prime-task effect. *Consciousness and Cognition*, *14*, 278-295.
- van Heuven, W., Dijkstra, T., Grainger, J. (1998). Orthographic neighbourhood effects in bilingual word recognition. *Journal of Memory and Language*, *39*, 458-483.
- van Petten, C., & Rheinfelder, H. (1995). Conceptual relationships between spoken words and environmental sounds: Event-related brain potential measures. *Neuropsychologia*, *33*, 485-508.
- Velasco, P. & García, O. (2014). Translanguaging and the Writing of Bilingual Learners. *Bilingual Research Journal*, *37*, 6-23.

- Vigliocco, G., Antonini, T., & Garrett, M.F. (1997). Grammatical gender is on the tip of Italian tongues. *Psychological Science*, 8, 314-317.
- Vouloumanos, A., Hauser, M., Werker, J., & Martin, A. (2010). The tuning of human neonates' preference for speech. *Child Development*, 81, 517-527.
- Werker, J., Shi, R., Desjardins, R. (1998). Three methods for testing infant speech perception. In A. Slater (Ed.) *Perceptual Development: visual, auditory, and speech perception in infancy* (517-27). Hove, U.K.: Psychology Press Ltd.
- West, W., & Holcomb, P. (2002). Event-related potentials during discourse-level semantic integration of complex pictures. *Cognitive Brain Research*, 13, 363-375.
- Williams, J. (1994b). The relationship between word meanings in the first and second language: Evidence for a common, but restricted, semantic code. *European Journal of Cognitive Psychology*, 6, 195-220.
- Williams, C. (1994a). *Arfarniad o Ddulliau Dysgu ac Addysgu yng Nghyd-destun Addysg Uwchradd Ddwyeithog*. PhD diss. Bangor University.
- Williams, C. (2002). Extending Bilingualism in the Education System. Education and Lifelong Learning Committee Report. *National Assembly for Wales*.
<http://www.assemblywales.org/3C91C7AF00023D820000595000000000.pdf>
 Accessed 19th September 2012.
- Zentella, A. (1997). *Growing up bilingual*. Malden, MA: Blackwell.