

**The role of pre-supplementary motor area in spatial vector transformation: Evidence from  
Parkinson's disease**

**Julie Hiralal Kerai**

**Bangor University**

**April 2013**

## Declaration and Consent

### Details of the Work

I hereby agree to deposit the following item in the digital repository maintained by Bangor University and/or in any other repository authorized for use by Bangor University.

**Author Name:** Julie Hiralal Kerai

**Title:** The role of pre-supplementary motor area in spatial vector transformation: Evidence from Parkinson's disease

**Supervisor/Department:** Professor E. Charles Leek/ School of Psychology

**Funding body (if any):** Bangor University 125<sup>th</sup> Anniversary Research Scholarship

**Qualification/Degree obtained:** Doctor of Philosophy

This item is a product of my own research endeavours and is covered by the agreement below in which the item is referred to as "the Work". It is identical in content to that deposited in the Library, subject to point 4 below.

### Non-exclusive Rights

Rights granted to the digital repository through this agreement are entirely non-exclusive. I am free to publish the Work in its present version or future versions elsewhere.

I agree that Bangor University may electronically store, copy or translate the Work to any approved medium or format for the purpose of future preservation and accessibility. Bangor University is not under any obligation to reproduce or display the Work in the same formats or resolutions in which it was originally deposited.

**Bangor University Digital Repository**

I understand that work deposited in the digital repository will be accessible to a wide variety of people and institutions, including automated agents and search engines via the World Wide Web.

I understand that once the Work is deposited, the item and its metadata may be incorporated into public access catalogues or services, national databases of electronic theses and dissertations such as the British Library's EThOS or any service provided by the National Library of Wales.

I understand that the Work may be made available via the National Library of Wales Online

Electronic Theses Service under the declared terms and conditions of use

(<http://www.llgc.org.uk/index.php?id=4676>). I agree that as part of this service the National

Library of Wales may electronically store, copy or convert the Work to any approved medium or

format for the purpose of future preservation and accessibility. The National Library of Wales is

not under any obligation to reproduce or display the Work in the same formats or resolutions in

which it was originally deposited.

**Statement 1:**

This work has not previously been accepted in substance for any degree and is not being concurrently submitted in candidature for any degree unless as agreed by the University for approved dual awards.

Signed ..... (candidate)

Date .....

**Statement 2:**

This thesis is the result of my own investigations, except where otherwise stated. Where correction services have been used, the extent and nature of the correction is clearly marked in a footnote(s).

All other sources are acknowledged by footnotes and/or a bibliography.

Signed ..... (candidate)

Date .....

**Statement 3:**

I hereby give consent for my thesis, if accepted, to be available for photocopying, for inter-library loan and for electronic repositories, and for the title and summary to be made available to outside organisations.

Signed ..... (candidate)

Date .....

**NB:** Candidates on whose behalf a bar on access has been approved by the Academic Registry should use the following version of **Statement 3:**

**Statement 3 (bar):**

I hereby give consent for my thesis, if accepted, to be available for photocopying, for inter-library loans and for electronic repositories after expiry of a bar on access.

Signed ..... (candidate)

Date .....

**Statement 4:**

Choose **one** of the following options

<p>a) I agree to deposit an electronic copy of my thesis (the Work) in the Bangor University (BU) Institutional Digital Repository, the British Library ETHOS system, and/or in any other repository authorized for use by Bangor University and where necessary have gained the required permissions for the use of third party material.</p>	
<p>b) I agree to deposit an electronic copy of my thesis (the Work) in the Bangor University (BU) Institutional Digital Repository, the British Library ETHOS system, and/or in any other repository authorized for use by Bangor University when the approved <b>bar on access</b> has been lifted.</p>	
<p>c) I agree to submit my thesis (the Work) electronically via Bangor University's e-submission system, however I <b>opt-out</b> of the electronic deposit to the Bangor University (BU) Institutional Digital Repository, the British Library ETHOS system, and/or in any other repository authorized for use by Bangor University, due to lack of permissions for use of third party material.</p>	

*Options B should only be used if a bar on access has been approved by the University.*

**In addition to the above I also agree to the following:**

1. That I am the author or have the authority of the author(s) to make this agreement and do hereby give Bangor University the right to make available the Work in the way described above.

2. That the electronic copy of the Work deposited in the digital repository and covered by this agreement, is identical in content to the paper copy of the Work deposited in the Bangor University Library, subject to point 4 below.
3. That I have exercised reasonable care to ensure that the Work is original and, to the best of my knowledge, does not breach any laws – including those relating to defamation, libel and copyright.
4. That I have, in instances where the intellectual property of other authors or copyright holders is included in the Work, and where appropriate, gained explicit permission for the inclusion of that material in the Work, and in the electronic form of the Work as accessed through the open access digital repository, *or* that I have identified and removed that material for which adequate and appropriate permission has not been obtained and which will be inaccessible via the digital repository.
5. That Bangor University does not hold any obligation to take legal action on behalf of the Depositor, or other rights holders, in the event of a breach of intellectual property rights, or any other right, in the material deposited.
6. That I will indemnify and keep indemnified Bangor University and the National Library of Wales from and against any loss, liability, claim or damage, including without limitation any related legal fees and court costs (on a full indemnity bases), related to any breach by myself of any term of this agreement.

Signature: .....

Date : .....

## Acknowledgements

Foremost, I would like to express my sincere gratitude to my supervisor Prof. Charles Leek, for his guidance and support throughout the process of my PhD, especially when I have made mistakes. I'd also like to thank Dr. Martyn Bracewell and Dr John Hindle for their help and advice.

Thanks to my fellow members of the Leek Lab, past and present in particular Dr Lina Davitt and Dr Fil Cristino. It has been a pleasure to have worked with you and your advice along the way has been invaluable.

Thank you to my dear friends Alice Pyke and David Morris for their spiritual presence and offers of refuge throughout the past three years. Thank you both for our lovely chats and reassurance when the future looked bleak.

Thanks to my friends Kat Burnett, Biddy Andrews and Lowri Hadden for all the fun and laughter along the way. I will look back on cookie making, piggery pottery, the quest for the 'mythical' Dyserth Falls and topics not to talk about in front of Biddy with fond memories.

Chad Cole, where do I start? Oh yes, giving me somewhere to live. Meeting you in the weeks before starting my PhD, I consider as one of the most fortunate occurrences in my life. Thank you for being there (and staying) through tears and tantrums and changing "I can't" into "you can". I have enjoyed visiting new places with you, even when my life has been at risk crossing the top of Aber Falls, canoeing backwards down parts of the River Wye and tobogganing down mountain sides in Brixen! I can't express how grateful I am to be in your life and how much this work has been enhanced and made easier by you being in mine.

Finally I'd like to thank my Dad, Mum, sister Nisha and brother Vishay for their constant love and support, only a phone call away.

Thank you

## Table of Contents

Declaration and Consent.....	2
Acknowledgements .....	7
Table of Contents .....	8
List of Figures .....	13
List of Tables .....	16
Abstract.....	17
Thesis Overview and Aims .....	18
Chapter 1 Visuospatial processing in the brain.....	21
Chapter Overview.....	21
1.1 Processing Visual Information .....	22
1.2 Pathways for object recognition.....	22
1.2.1 The “what” /“where” pathways .....	22
1.2.2 The perception/action pathways.....	24
1.3 Why is understanding spatial representation relevant to vision? .....	25
1.4 Spatial reference frames .....	25
1.5 Neuropsychology of spatial representation .....	27
1.6 Mental Rotation.....	29
1.7 The Neural Correlates of Mental Rotation .....	30
1.8 The link between Manual and Mental Movement .....	31
1.9 Summary .....	34
Chapter 2 The Supplementary Motor Area.....	36
Chapter Overview.....	36



2.2 Anatomy and connectivity of supplementary motor areas .....	37
2.3 Functional heterogeneity of the supplementary motor areas.....	38
2.3.1 Planning and preparation of movement.....	39
2.3.2 Internally vs. Externally generated movement.....	40
2.3.3 Movement Selection and Action Control .....	41
2.3.4 Visuospatial transformation.....	42
2.4 The Vector Transformation Hypothesis .....	44
2.5 Summary .....	45
Chapter 3 Parkinson's disease.....	46
Chapter Overview.....	46
3.1 The basal ganglia circuit.....	46
3.2 The pathology of Parkinson's disease .....	47
3.3 Symptoms.....	50
3.4 Cognitive Impairment in Parkinson's disease .....	51
3.5 Visuospatial cognition impairments in Parkinson's disease .....	53
3.5.1 Mental Rotation in Parkinson's disease .....	55
3.5.2 Visuospatial Working Memory.....	57
3.6 What accounts for the visuospatial deficit in PD?.....	58
3.7 Summary .....	60
Chapter 4 Study I: An investigation of mental rotation impairment in Parkinson's disease .....	62
Chapter Overview.....	62
Introduction .....	63

Methods.....	66
Participants .....	66
Experimental tasks.....	68
Stimuli.....	68
Apparatus.....	69
Design & Procedure .....	70
Results.....	73
Experimental Tasks.....	73
Discussion .....	79
Chapter 5 Study II: An investigation of vector transformation processes in visuospatial tasks other than mental rotation .....	83
Chapter Overview.....	83
Introduction .....	84
Methods.....	87
Participants .....	87
Neuropsychological Background and Screening Tests. ....	87
Apparatus.....	90
Experimental tasks.....	90
Results.....	94
Task 1: Spatial Memory .....	94
Task 2: Sequential Vector Transformation Vs Task 3: Sequential Number Subtraction.....	95
Task 2: Sequential Vector Transformation.....	96

Task 3: Sequential Number Subtraction .....	97
Further Analysis of Screening Measures .....	97
Discussion .....	100
Chapter 6 Study III: An investigation of the domain specificity of pre-SMA in vector transformation processes .....	106
Chapter Overview.....	106
Introduction .....	107
Methods.....	110
Participants .....	110
Screeners.....	110
Experimental Tasks.....	112
Task 1: Visual Transformation Task.....	112
Task 2: Auditory Transformation Task.....	114
Results.....	115
Accuracy Analysis.....	115
VOT Data Analysis .....	117
The individual level of analysis .....	117
Discussion .....	121
Chapter 7 An investigation of pre-SMA activation during cognitive rehabilitation to improve motor reaching in Parkinson's disease.....	125
Chapter Overview.....	125
Introduction .....	126

Methods.....	131
Participants .....	131
Neuropsychological Background and Screening Tests .....	131
Stimuli.....	133
Apparatus.....	133
Behavioural Experimental Tasks .....	134
Motor Reaching Task.....	136
General Procedure .....	136
Results.....	138
Analysis of Behavioural Experimental Tasks.....	138
Analysis of Motor Reaching .....	139
Correlation Analysis .....	144
Discussion .....	144
Clinical Implications .....	146
Chapter 8 General Discussion .....	149
8.1 Impaired Visuospatial Transformation in PD.....	153
8.2 The Vector Transformation Hypothesis .....	155
8.3 Clinical Heterogeneity in Parkinson's disease.....	157
8.4 Summary and Conclusions.....	159
References .....	160
Appendices .....	206

## List of Figures

- Figure 1.1. Illustration of the dorsal stream (green) and ventral stream (purple) both originating from the visual cortex in the occipital lobe (Ungerleider & Mishkin, 1982).....23
- Figure 1.2. Coordinate mapping across viewer-centred and object-centred reference frames. The axis can be defined from a viewer-centred reference frame where the origin of the axis is externally defined. When objects assigned viewer-centred reference frames are rotated, the coordinate representations of the object features change. In object centred reference frames, the axis is defined using parts of the object which remain the same across changes in object orientation. ....26
- Figure 1.3. Illustration of the COR hypothesis which assumes that the visual system maps viewer-centred representations onto object-centred representations as seen on the left. The COR orientation is defined by the polarity correspondence and the tilt angle calculated by the angular discrepancy between the two axes. ....28
- Figure 1.4. Schematic illustration of linearly increasing reaction times with angular disparity between stimulus pairs as shown in the classic mental rotation experiment (Shepherd & Metzler, 1971). ....29
- Figure 2.1. Caudal-rostral sub-divisions for SMA (F3) and pre-SMA (F6) with distinct connectivity to striatum. (Lehéricy et al. 2004). The figure on the left shows the comparison of tracks coming from the SMA (green) and pre-SMA (yellow). In the righthand figures, we see the comparison of tracks coming from the SMA (green) and motor cortex (red). ....37
- Figure 2.2 Activation of anterior part of medial premotor cortex (pre-supplementary motor area) during abstract mental rotation of 2D novel shape representations. This activation provides evidence that pre-SMA is involved in the computation of visuospatial transformations (Johnston et al. 2004).....44
- Figure 3.1. Normal functional anatomy of the basal ganglia. The arrows point in the direction of different tracts and the colors indicated on the right show the neurotransmitters involved at each

level. The positive sign near the end of the tract indicates that the impulses are excitatory, while the negative sign indicates inhibitory impulses. For reference, keep in mind the width of these tracks is proportional to the strength of the signal. Of special interest are the dopaminergic pathways and the excitatory glutamatergic pathways. Retrieved from:

[http://www.mdvu.org/library/disease/pd/par\\_path.asp](http://www.mdvu.org/library/disease/pd/par_path.asp) .....49

Figure 3.2. Pathologic functional anatomy of the basal ganglia in Parkinson's disease. This second diagram shows the changes in the basal ganglia cortical circuitry after substantia nigra compacta damage. The main features are the reduced dopaminergic impulses from substantia nigra to the striatum, enhanced excitation of the subthalamic nucleus and the globus pallidus internus, and increased inhibition of the thalamus. Retrieved from:

[http://www.mdvu.org/library/disease/pd/par\\_path.asp](http://www.mdvu.org/library/disease/pd/par_path.asp) .....49

Figure 4.1. (a) Schematic procedures for Task 1 (Mental rotation) and Task 2 (Recognition memory). (b) The novel object stimulus sets for both tasks. These objects are shown in at the 0° or upright orientation.....69

Figure 4.2. Mean regression slopes (ms/deg) for the PD and controls groups on each task. ....76

Figure 5.1. Trial Sequences for Tasks 1, 2, and 3.....90

Figure 5.2. Mean percentage accuracy and response times (ms) across ISI conditions on the spatial memory task for PD patients and controls on the spatial short term memory task. Error bars represent standard error of the mean.....95

Figure 5.3. Percentage accuracy across the sequential processing tasks as a function of group and sequence length. Error bars represent standard error of the mean. ....96

Figure 6.1. Trial representation of Visual Vector Transformation Task.....113

Figure 6.2. Visual representation of trial structure for auditory vector transformation task.....115

Figure 6.3. . Mean percentage accuracy between groups across Sequence Length and Task. Error bars represent standard error of the mean. ....116

Figure 6.4. Scatter plots showing percentage accuracy data for the Control and PD groups on (a) Visual Vector Transformation Task and (b) Auditory Vector Transformation Task. ....	118
Figure 6.5. Individual performances of the Parkinson's disease patients who showed impairments on any of the vector transformation tasks. Values represent t-test values of the Crawford Modified t-test designed to compare single cases to a control sample.....	119
Figure 7.1 A scientific diagram of the Light Cue Box. ....	134
Figure 7.2. Trial presentation of Auditory Vector Transformation Task. ....	135
Figure 7.3. Trial presentation of Auditory Sequence Memory Task.....	136
Figure 7.4. General task order for motor reaching task with both intervening task structures.....	137
Figure 7.5. Mean percentage accuracy for the two behavioural tasks across the three sequence length conditions. Error bars show standard error of the mean. ....	138
Figure 7.6. Crawford Modified t statistic on percentage improvement for individual patient performance on Auditory Vector Transformation: (a) Movement Velocity , (b) Movement Onset.	140
Figure 7.7 . Crawford Modified t statistic on percentage improvements for individual patient performance on Auditory Sequence Memory task: (a) Movement Velocity, (b) Movement Onset. ....	141

## List of Tables

Table 4.1. PD motor scores, ages, sub-types and neuropsychological screeners. Control mean (SD). .....	67
Table 4.2. Mean Voice-onset times (VOTs) per condition and accuracy (% correct). Brackets show standard error of the mean. ....	73
Table 4.3. Pearson’s correlations for regression slopes for spatial normalisation and screening measures.....	78
Table 5.1. Mean control and individual patients’ scores on screeners. ....	89
Table 5.2. Bivariate correlations for screening measures and tasks.....	99
Table 6.1. Mean control and individual patients’ scores on screeners. ....	111
Table 6.2. Pearsons’ correlations between measures on Visual and Auditory Vector Transformation Tasks and Neuropsychological screeners. ....	120
Table 7.1. Mean control and individual patients’ scores on screeners. ....	132
Table 7.2. Pearson’s correlations for Movement Improvement and Screening Measures on Auditory Vector Transformation.....	142
Table 7.3. Pearson's correlations for Movement Improvement and Screening Measures for Auditory Sequence Memory. ....	143



## Abstract

This thesis investigated the role of the supplementary motor area (SMA) in visuospatial processing using Parkinson's disease (PD) patients as a model of pre-supplementary motor area (pre-SMA) dysfunction.

The vector transformation hypothesis assumes that visuospatial transformation deficits in PD are a result of impairments in calculating vectors or co-ordinate remapping with a reference frame. These vector transformation processes were investigated in spatial normalisation during mental rotation and showed that PD patients demonstrate slower image normalisation rates indicative of a deficit compared with controls. It was then investigated how far these deficits extend to other vector transformation tasks such as abstract grid navigation. PD patients were less accurate than controls and these deficits were independent of spatial short term memory and serial processing suggesting that PD is associated with spatial transformation deficits. Comparisons of visual vector transformation and auditory vector transformation showed that PD patients were less accurate at visual vector transformation than auditory vector transformation suggesting that vector transformation processes may be more sensitive to the visual domain. The final study was a pilot study to investigate the feasibility of using a cognitive vector transformation task to remediate symptoms of bradykinesia in PD. Modest improvements in movement velocity following the vector transformation task but no significant change in movement velocity following a control task suggests that vector transformation can be used for therapeutic gain.

## Thesis Overview and Aims

The aim of the thesis is to investigate the contribution of supplementary motor areas in spatial vector transformation using Parkinson's disease (PD) patients as a model of pre-supplementary motor area (pre-SMA) dysfunction.

Spatial transformations are imagined or performed spatial re-mappings of features within a reference frame. An example of such spatial transformations is mental rotation. The mental rotation phenomenon shows that the time taken to judge whether two images are the same or different linearly increases with the angular disparity between the two images (e.g. Shepard & Metzler, 1971; Cooper & Shepard, 1973). When completing a mental rotation task at the same time as a motor function, performance was faster and more accurate when mental and manual movements were congruent (Wexler, Kosslyn & Berthoz, 1998) suggesting that mental transformations are subject to the same constraints as manual transformations. This link between manual and mental movement has been further supported for example, by interference effects between concurrent manual and mental movement (Wohlschlagel & Wohlschlagel, 1998).

Recent imaging studies have reported activation of premotor cortices during mental rotation tasks. Given what we know about the association between manual and mental movement, it is not surprising that associative motor areas are involved in mental rotation. Rather than the mechanisms underlying movement execution in primary motor cortex, it is likely that mental rotation processes would require regions responsible for the planning and preparation of movement in pre-motor cortex (Wexler, Kosslyn, & Berthoz, 1998).

The medial supplementary motor areas have been associated with the planning and preparation of internally generated movement (Luppino, Matelli, Camarda, Gallese, & Rizzolatti, 1991; Musiacke et al., 1991; Passingham, 1993; Matsuzaka, Aizawa, & Tanji, 1992; Picard & Strick, 1996; 2001). More recently, anatomical and functional subdivisions were identified, labelled the (caudal) SMA proper and (rostral) pre-SMA (Luppino et al., 1991; Matsuzaka et al., 1992, 1996;

Picard & Strick, 1996, 2001). While SMA proper has been associated with the onset of movement execution (Lee, Chang, & Roh, 1999; Picard & Strick, 1996; 2001), the role of pre-SMA has been deemed more abstract in pre-movement planning and the selection of responses (Alexander & Crutcher, 1990; Rizzolatti et al., 1990; Matsuzaka et al., 1992; Shima, Mushaike, Saito, & Tanji, 1996; Shima & Tanji, 1998). In addition, pre-SMA activation has also been observed during mental imagery (Johnston, Leek, Atherton, Thacker, & Jackson, 2004; Richter et al., 2000; Windischberger, Lamm, Bauer, & Moser, 2003), suggesting that this region generates and encodes motor representations prior to movement. Ensuing research suggests that pre-SMA may support non-motor as well as motor processes such as mental visuospatial transformations (Johnston, Leek, Atherton, Thacker, & Jackson, 2004; Richter et al., 2000; Windischberger, Lamm, Bauer, & Moser, 2003) proposing a link between movement planning and abstract visuospatial transformations.

The vector transformation hypothesis (Leek & Johnston, 2009) proposes that one function of pre-SMA is the computation of transformations required to map spatial locations via a transformation matrix. Thus, the pre-SMA does not support movement through dedicated motor planning operations, but rather through the use of cognitively or computationally abstract spatial vector transformations which are used in both motor and non-motor tasks requiring the remapping of spatial locations. The vector transformation hypothesis assumes that these computations underlie a variety of tasks including the planning and online control of visually guided movement via the calculation of movement trajectories, as well as abstract visuospatial transformation tasks, including any task requiring the remapping of feature locations such as mental rotation.

Given its underlying pathology, and the consequent effects of striatal dopamine depletion on the SMA, this hypothesis specifically predicts visuospatial transformation impairments in PD. The spatial remapping function of pre-SMA as proposed by the vector transformation hypothesis is by association likely to be dysfunctional in PD and may underlie visuospatial transformation

impairments observed in PD. To test this hypothesis, the studies presented here investigate PD patient's performance on a series of tasks involving vector transformation processes.

Chapter 1 provides a brief overview of visuospatial transformation and why spatial representations are important for how we interact with our environment. The spatial organisation of vision in the brain is discussed, as well as the neural correlates of visuospatial transformation. Chapter 2 reviews the evidence of the function of the supplementary motor areas (SMA) including anatomical and functional subdivisions before looking at the contribution of SMA to imagery and visuospatial transformation. Also discussed are the cortical connections of SMA proper and pre-SMA and how these connections inform the vector transformation hypothesis. Chapter 3 comprises of an overview of PD covering the pathology of the disease and symptom presentation. The cognitive impairments of PD are discussed with particular attention to visuospatial cognition.

Study I (Chapter 4) investigates the vector transformation hypothesis in spatial normalisation processes engaged in mental rotation in PD patients. Study II (Chapter 5) investigates how vector transformation impairments observed in mental rotation in PD extend to other visuospatial tasks such as abstract grid navigation. The domain generality of vector transformation is tested in Study III (Chapter 6), comparing vector transformation in the visual and auditory modalities. In Study IV (Chapter 7), the knowledge about vector transformation and acquired from preceding chapters is applied to a cognitive rehabilitation task to investigate the effects of pre-SMA activation on motor function in PD. The general discussion provides an overview of the principal empirical and theoretical contribution of the work described in the thesis, and relates these findings more broadly to other empirical theoretical and clinical findings in this field.

# Chapter 1

## Visuospatial processing in the brain

### Chapter Overview

This chapter describes the processing of visual information from when it enters the eye to when more complex features such as form, depth, motion and colour are processed. Considered, are the distinct processing pathways for object identity and the spatial location of objects as well as how viewers orient themselves in order to interact with the environment.

Also examined is the nature of spatial representation of vision for skills such as orientation invariant object recognition, spatial attention, navigation and interacting with our environment. One hypothesis for how the visual system represents the orientation and location of objects is via spatial reference frames which map the spatial locations of features of a representation in a coordinate system (Leek & Johnston, 2009).

Disorders of spatial representations are considered in terms of how they can disrupt an individual's ability to create internal spatial representations or reference frames. Internal spatial reference frames can undergo mental transformations as is the case with mental rotation. Mental rotation has been investigated in a variety of paradigms and research shows that mental movements and manual movements activate overlapping cortical regions, namely, supplementary motor areas.

The cortical overlap between mental and manual movement suggests that the functions of premotor cortex go beyond movement planning to a more computational role in motor movement planning. It is unclear what role supplementary motor areas, traditionally associated with the planning and preparation of movement, play in abstract visual mental rotation.

## 1.1 Processing Visual Information

Information processing in the brain begins as soon as visual information hits the retina. When light enters the eyes, it travels through axons of ganglion cells, amacrine cells, bipolar cells and horizontal cells where the light is received by rods and cones. The rods and cones send information back to the centre of the eye. The axons of the retinal ganglion cells form the optic nerve through which visual information travels into the brain. The optic nerves cross at the optic chiasm. After the axons of the retinal ganglion cells have passed the optic chiasm, they are collectively known as the optic tract. Most of the axons of the optic tract terminate in the lateral geniculate nucleus (LGN); the visual portion of the thalamus. Afferences from the optic tract and LGN are received by the pulvinar, the posterior portion of the thalamus. Ten percent of ganglion cells project to the superior colliculus which in turn project to other subcortical structures including the reticular formation, inferior colliculus and the spinal cord. As information leaves the primary visual cortex, more complex aspects of the visual world are processed and separated into form, depth, motion and colour.

## 1.2 Pathways for object recognition

It is proposed that object recognition is processed in two processing pathways in the brain. Distinctions have been made in terms of how these pathways are conceptualised; 1) the “what”, “where” hypothesis and 2) the action perception hypothesis. These accounts will now be discussed with associated evidence.

### 1.2.1 The “what” / “where” pathways

Ungerleider and Mishkin (1982) proposed that visual information is transmitted from the visual cortex via two visual streams; the dorsal stream and the ventral stream. The dorsal stream, also known as the “where” stream, is assumed to be involved in the guidance of actions and interpreting where objects are in space. This pathway extends from the primary visual cortex in

the occipital lobe forward into the parietal lobe. The two functions of the dorsal stream are to 1) represent a spatial map of the visual field and 2) to detect and analyse movements. Sensory inputs are processed in the occipital lobes before processing spatial information in the parietal lobe. This spatial processing is essential for perceiving and interpreting spatial relationships and the coordination of the body in space; proprioception (Bear, Connors, & Paradiso, 2007).

The ventral stream, associated with object recognition, stretches from the primary visual cortex to the temporal cortex. Also known as the “what” stream, it processes the features of objects that are relevant to their identity such as colour and form. The ventral stream goes from the primary visual cortex to the temporal cortex via visual areas V2, V3 and V4. Each visual area contains a full representation of space and is made up of neurons whose receptive fields together, represent the entire visual field.

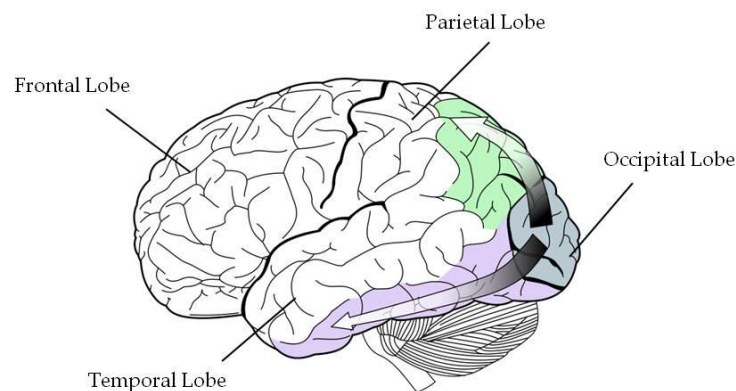

**Figure 1.1. Illustration of the dorsal stream (green) and ventral stream (purple) both originating from the visual cortex in the occipital lobe (Ungerleider & Mishkin, 1982)**

One source of evidence to support the segregation of pathways for visual spatial and visual object processing can be seen in patients with form agnosia and optic ataxia. Visual form agnosics have difficulties with object recognition despite intact motion detection or representation of orientation (Goodale, Jakobson, & Keillor, 1994; Milner, Dijkerman, & Carey, 1999; Goodale et al., 2008; Goodale et al., 1994; Rice, et al., 2006). Optic ataxia is characterised by intact performance when a delay is introduced between the visual stimulus and motor response, and diminished performance when the response immediately follows the stimulus, (Goodale, et al., 1994;

Himmelbach & Karnath, 2005; Milner et al., 2003; Rice et al., 2008; Schindler et al., 2004). Patients with damage to structures in the ventral stream may develop visual form agnosia. Research shows that some patients demonstrate impaired object perception but spared reaching and grasping and shape size judgements (Milner et al., 1991; James, Culham, Humphrey, Milner, & Goodale, 2003), thus supporting the distinction between the dorsal and ventral pathways. Further, patients with posterior parietal lesions show impaired spatial information processing but intact object information processing (Kessels, Postma, Kappelle, & de Haan, 2000; Newcombe, Ratcliff, & Damasio, 1987; Farah, Hammond, Levine, & Calvanio, 1988), a dissociation which supports independent processing pathways.

A subsequent study compared activation on a spatial matching task and an object identity matching task and found more activation of dorsal right inferior parietal lobe during spatial matching than object matching and more bilateral ventral occipitotemporal activation during object matching than spatial matching, further supporting the double dissociation between the “where” and “what” streams (Kohler, Kapur, Moscovitch, Winocur, & Houle, 1995).

### **1.2.2 The perception/action pathways**

Goodale and Milner (1991) proposed a distinction between vision for perception and vision for action which argues that the dorsal stream is more appropriately characterised as a “how” rather than as a “where” pathway relative to a specific action. The close connections to the motor system allow the dorsal stream to encode the location of objects and their movement depending on how an observer might interact with the object, (Goodale et al., 1991).

Evidence from neuropsychological research to support this assumption comes from an agnosic patient with a bilateral lesion of occipitotemporal cortex and a small left sided lesion of the occipitoparietal cortex. The patient demonstrated impairments of object perception (distinguishing a square from a rectangle) but spared ability to accurately reach for objects with the appropriate



grasping gestures for the shape and size of the object. Furthermore, the patient was unable to accurately describe or adjust the orientation of her hand to match the orientation of a distant slot but was accurate in orienting her hand when reaching for the same slot suggesting the dorsal stream has a visuomotor association (Goodale, Milner, Jakobson, & Carey, 1991).

This was supported by subsequent findings that neurons in the dorsal stream of monkeys were not concerned with where the objects were but the shape and size of the objects being reached for (Sakata, Taira, Murata & Mine, 1995). Thus, the dorsal stream processes more complex spatial information than spatial location.

### **1.3 Why is understanding spatial representation relevant to vision?**

The mental representation of space is necessary for us to determine object orientation, recognise objects at different orientations, to form different viewpoints, allocate spatial attention, reach for and grasp objects and to navigate around our environment.

Visual spatial cognition refers to the processes of mentally representing and manipulating visual information and how this information is interpreted or constructed. It is a complex set of functions and involves skills such as the orienting of attention and navigation.

### **1.4 Spatial reference frames**

How does the visual system represent spatial information such as the location and orientation of sensory stimuli? One hypothesis is that spatial representation involves the use of reference frames as depicted in Figure 1.2 (McCloskey, 2001). A reference frame is a system that uses coordinates to establish positions in space. To do so, an origin and an axis or matrix need to be specified. Visual stimuli can be presented in an object-centred reference frame or in a viewer-centred reference frame (McCloskey, 2001). The reference frames differ in how the axes are defined; internally for object-centred representations and externally for representations defined by any number of external properties for example head-centred, monitor-centred, or viewer-centred.

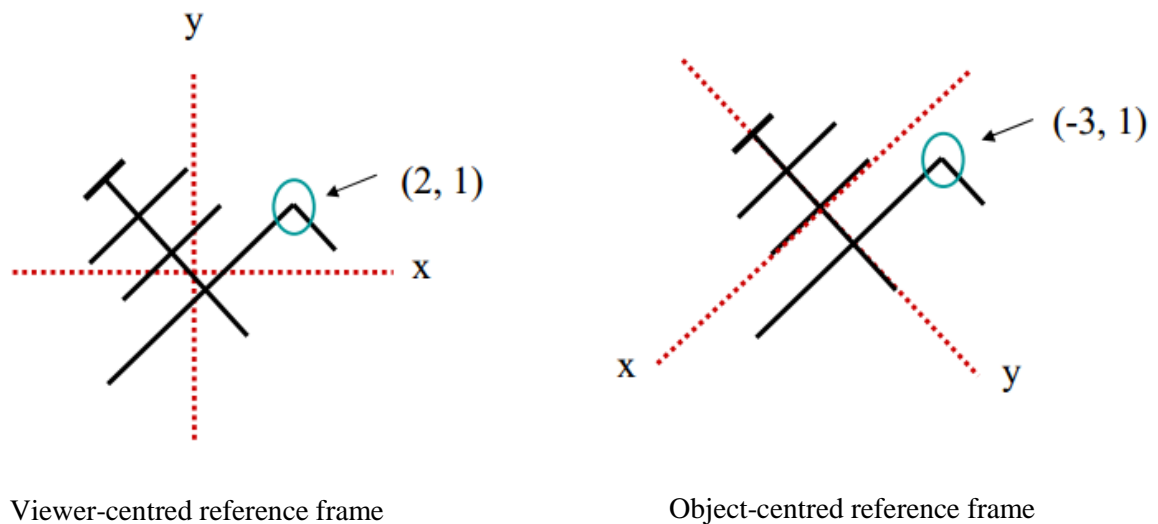

**Figure 1.2. Coordinate mapping across viewer-centred and object-centred reference frames. The axis can be defined from a viewer-centred reference frame where the origin of the axis is externally defined.**

**When objects assigned viewer-centred reference frames are rotated, the coordinate representations of the object features change. In object centred reference frames, the axis is defined using parts of the object which remain the same across changes in object orientation.**

Object-based reference frames are defined relative to external objects and locate things relative to one or more axes defined with respect to a particular object. These reference frames enable us to define the relationship between the parts of an object independent of the object's location in the visual field, e.g. the handle of the cup is on the right of the main cup vessel, or the orientation at which the object is seen.

Viewer-centred reference frames are defined relative to the viewer. The origin relates to externally defined spatial locations. They can be eye-centred, whereby the locations of objects in the reference frame change every time the eyes move; or head-centred. In this situation, the location of objects does not change when the eyes move but when the head moves. Head-centred reference frames could be defined, for example, relative to the midline of the head. Viewer-centred reference frames are crucial for controlling action because, to reach out and grab something, it is necessary to identify where an object is with reference to the external environment, the body, and

the limbs to judge the direction and distance one needs to reach and grasp the object in question.

This definition of direction and amplitude is called a vector.

Thus, reference frames use coordinate systems to establish locations in space. These reference frames are defined internally or externally. In viewer-centred representations, the spatial locations of features within the reference frame vary across changes in object orientation whereas in object-centred representations, spatial locations of features within the reference frame remain constant across changes in object orientation.

### **1.5 Neuropsychology of spatial representation**

Developmental and acquired abnormalities in visual cognition can enable us to learn more about the way spatial information is processed in the brain. Such a developmental impairment of visual cognition was reported by McCloskey et al., (1995). AH was a right handed university student with normal visual acuity and no history of neurological injury or disease. AH demonstrated highly systematic location and orientation errors in the form of left-right and top-down reflections on a series of visual tasks. However what was most interesting about this case was that AH's mis-location of visual stimuli was not completely unrelated to the correct location. The erroneous movements were made with the correct distance and eccentricity but in the wrong direction relative to the midline suggesting that representations of mental space have an internal structure involving multiple independent components. McCloskey, Valtonen and Sherman (2006), proposed that object locations are represented in a spatial coordinate system defined by a reference point that represents the origin and orthogonal axes through that point. It can also be assumed that distance and direction of displacement along an axis are represented independently (McCloskey & Rapp, 2000).

In addition, a patient with a right inferior parietal lesion following a cerebral vascular incident demonstrated normal object recognition but was unable to detect mirror reflections across the y

axis. Reflections across the x axis remained unaffected, as did straightforward image plane rotations suggesting that deficits can occur specific to particular reference frame transformations.

Such representation impairments can be explained in part by the Coordinate-system Orientation Representation (COR) hypothesis (McCloskey, 2009). The hypothesis assumes that object orientation is encoded by relating an object centred representation of the stimulus to a viewer-centred representation by specifying the polarity correspondence, tilt direction and magnitude.

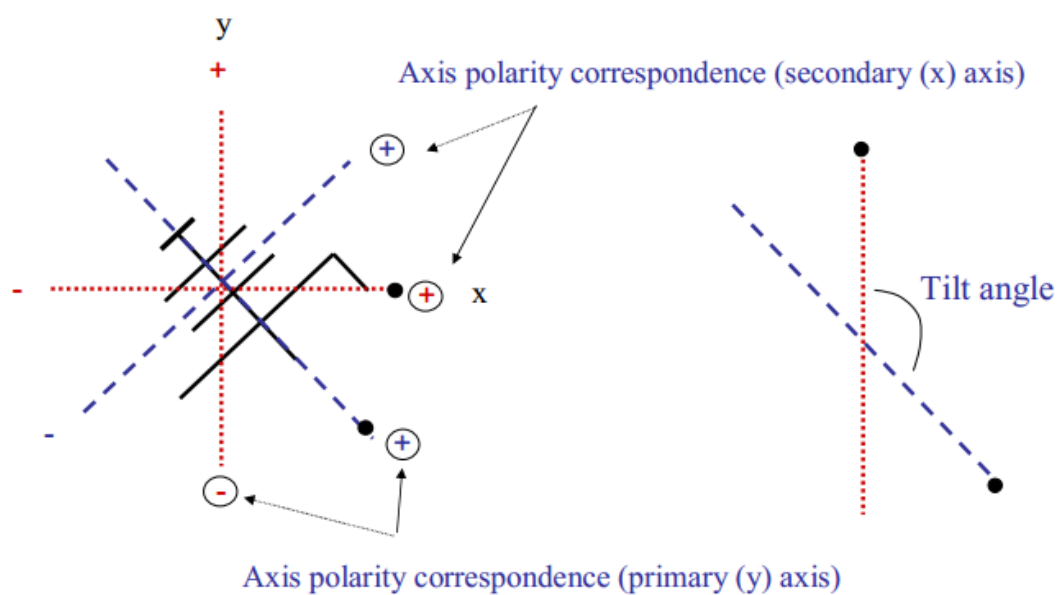

**Figure 1.3.** Illustration of the COR hypothesis which assumes that the visual system maps viewer-centred representations onto object-centred representations as seen on the left. The COR orientation is defined by the polarity correspondence and the tilt angle calculated by the angular discrepancy between the two axes.

The tilt of the image representation is calculated by the angular discrepancy between the axis polarities of the two representations (Figure 1.3). Reflection errors are assumed to arise from failure to assign correct polarity correspondences, e.g. when the primary axis is assigned as [-] instead of [+].

This research provides evidence for the visual system representing spatial information via spatial reference frames. These internal reference frames can undergo mental transformations such as mental rotation.

## 1.6 Mental Rotation

Mental rotation, a term originally coined by Shepard and Metzler (1971), is the spatial transformation of a reference frame. In their original research, Shepard and Metzler showed that when subjects were asked to judge whether objects were identical or mirror images of each other, response times increased linearly with the angle of rotation from its original position as depicted in Figure 1.4 (Shepard & Metzler, 1971). Findings suggested that participants “mentally rotated” the image of the stimulus object until it had the same orientation as the target stimulus. All subjects participating in the experiment reported using imagery in this mental rotation process, (Shepard & Metzler, 1971).

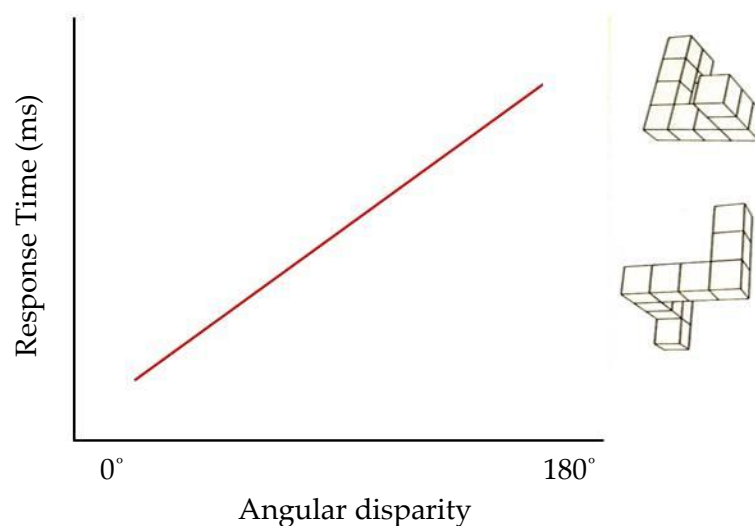

**Figure 1.4. Schematic illustration of linearly increasing reaction times with angular disparity between stimulus pairs as shown in the classic mental rotation experiment (Shepherd & Metzler, 1971).**

Subsequent research by Cooper and Shepard (1973) found that when advanced information regarding the orientation of a stimulus shape was presented before the test stimulus, participants could begin the mental rotation process early. No increase in reaction times was observed with increased angular disparity if participants were given enough time to complete the mental rotation. This suggested that progressively more time was required for every additional amount that an object needed to be mentally transformed implying that at some level the mental

rotation of objects shares cognitive substrates with the physical rotation of objects. This relationship is explored later.

Tarr and Pinker (1989) found that when participants made match/mismatch judgements to previously stored representations, image normalisation slopes increased with angular variance. These findings showed that participants matched stimuli by rotating stimuli to match the orientations of the stored representations. Similarly, Leek, Atherton and Thierry (2007) showed that object constancy is achieved in part by orientation dependent visuospatial transformation implying that spatial transformation is a widely used cognitive process in object recognition.

### **1.7 The Neural Correlates of Mental Rotation**

Mental rotation processes have been described, but where do these processes occur in the brain? Disagreement prevails with regards to the function of cortical motor areas in mental rotation. Theoretical approaches imply that dynamic imagery and explicit movements rely on the same neural networks. Wexler et al., (1998) suggested that mental rotation would not recruit the cortical and sub cortical mechanisms liable for the execution of movement but instead involve motor planning and anticipation mechanisms.

Results from imaging studies have been inconclusive. Whereas some studies report premotor activation during mental rotation, (Cohen et al., 1996; Richter et al., 2000; Johnston et al., 2004), others have shown no involvement of the premotor cortex (Jordan, Heinze, Lutz, Kanowski, & Jäncke, 2001; Harris et al., 2000). Several studies suggest that the lateral premotor cortex/precentral gyrus and the supplementary motor area (medial premotor areas) are active in mental rotation, (Cohen et al., 1996; Lamm, Windischberger, Leodolter, Moser, & Bauer, 2001; Richter et al., 2000; Vingerhoets, de Lange, Vandemaele, Deblaere, & Achten, 2002; Johnston et al., 2004).

Inconsistencies among the findings may be due to methodological confounds. The tasks were varied across studies and it has been suggested that the rotation of non-abstract objects, such

as hands and feet may produce more activation in the motor areas including the premotor cortex, than abstract novel objects (Kosslyn, Digirolamo, Thompson, & Alpert, 1998; Parsons, 1994). Further confounds arising from imaging studies may lie in the tasks which require mirror image judgements for 3D stimulus objects which involve the element of depth (Cohen et al., 1996; Lamm et al., 2001; Richter, Ugurbil, Georgopoulos, & Kim, 1997). Neural activation may have been observed on these tasks due to the presence of cognitive processes and additional task demands placed on the rotation of 3D shapes. A study which addressed this issue will later be considered, (Johnston et al., 2004).

Extensive literature supports the role of the premotor cortex in the preparation and execution of movement (Lamm et al., 2001; Rushworth, Krams, & Passingham, 2001). Research also implicates the medial premotor cortex in the preparation and selection of internally generated movement; unprompted and self initiated movements, made in the absence of external cues (Deiber, Ibanez, Sadato, & Hallett, 1996). The lateral premotor areas on the other hand are involved in movement preparation and response execution to external cues (Hamzei et al., 2002; Passingham, 1996; Rowe & Passingham, 2001), supporting findings that associate the medial premotor cortex to abstract visuospatial transformation.

The aforementioned studies have reported that in the superior and inferior parietal cortex, prefrontal and motor areas are associated with mental rotation and suggest that the functions of the supplementary motor areas go beyond movement planning to a more computational role in mental rotation and motor planning (Wohlschlager & Wohlschlager, 1998).

## **1.8 The link between Manual and Mental Movement**

What are the underlying processes involved in spatial transformation? The relationship between manual and mental rotation was initially suggested by a linear relationship observed between angular disparity and response time in a mental rotation task (Shepard & Metzler, 1971).

This relationship may be interpreted as evidence for an internal mechanism for visuospatial transformation subject to the same constraints as analogue, physical transformation. Objects seem to move along continuous trajectories as they are transformed and the time taken to perform transformations is directly related to the magnitude of the transformation (Shepard & Cooper, 1982).

These findings suggest that rotation may be guided by processes that also prime specific motor actions. This hypothesis was investigated in a dual task paradigm where a task similar to the Cooper and Shepard (1973) mental rotation task was completed while executing a motor function in a given direction (Wexler et al., 1998). Performance was faster and more accurate when the direction of mental rotation and motor rotation were compatible than when the direction of the tasks was incompatible. When the direction of rotation was compatible, there was a correlation between the angle of mental rotation and the angle through which the joystick handle was rotated, supporting a direct relationship between manual and mental movement.

Several neuropsychological studies support an interaction between motor anticipation and mental image transformation. Activation has been reported in motor and visuomotor areas, particularly in posterior parietal cortex, motor and premotor cortex when performing mental rotations of images of hands (Parsons et al., 1995). Further, participants find it easier to rotate body parts in ways that are physically possible rather than rotating the images in physically awkward directions, suggesting that the mental transformation of body parts is associated with the ease of which the physical rotation of that body part is performed (Shepard & Cooper, 1982; Parson's 1987; Parsons, 1994).

When investigating the link between motor processes and mental image transformation of more arbitrary objects which do not have embedded motor system association, mental rotation and manual rotation was faster when the direction of concurrent tasks is congruent than when the direction is incongruent (Wohlschlager & Wohlschlager, 1998). No interference effects were



observed when transformations were made about a different axis. Taken with the findings of Wexler et al., (1998), these results provide direct evidence that mental and motor processes share a common link.

In a study where monkeys were trained to move a joystick to a lit target, researchers found that single M1 neurons fire for multiple directions but that each of these neurons has a preferred direction. The neuron would fire fastest in the preferred direction and slower as the direction moves further away from the preferred (Georgopoulos, Schwartz, & Kettner, 1986). Though individual cells in motor cortex have a directional preference, they are not direction specific, hence discharge in both preferred and non-preferred directions. However movements in certain directions engaged neurons with overlapping directional tuning curves. This suggests that the direction of movement is not subserved by specialised cells corresponding to a particular direction, but instead is coded in a directionally heterogeneous group of cells. Population coding refers to the way in which information is coded in a group of neurons. Each neuron has a distribution of responses over some sets of inputs.

To explain how motor cortical cells with directional preference and directional spread could generate movements in particular directions as populations, Georgopoulos et al., (1986) proposed a population vector hypothesis. The hypothesis assumes that cells exert a directional vector along the axis of their preferred direction. The directional vector is on the same axis for all directions of movements exerted toward the cells preferred direction when the discharge level is increased above average. For movement direction, the vectoral components of individual cells sum linearly.

Studies showed that in the motor cortex of monkeys, there was 'rotation' in the population vector that guided hand movement (Georgopoulos, Lurito, Petrides, Schwartz, & Massey, 1989). When making a movement that deviates angularly from a visually presented stimulus, movement onset time is linearly dependent on the angle of deviation. This supports the link between manual

and motor processes by suggesting that the motor process of planning a physical movement directly influences internal, and here, physiological movement processes.

The relationship between mental movement and physical movement has been further applied and investigated relative to training. An attempt to improve mental rotation performance by manual rotation training required participants to rotate a block figure to match the orientation of a target. A mental rotation test was administered to assess the impact of the manual training on mental rotation performance (Rizzo et al., 2001). No significant differences were found between the group that received the training and the control group who performed a non-spatial filler task. Thus manual rotation training does not influence mental rotation ability, contradicting the proposed relationship between manual and mental rotation. There were however some important methodological factors which may account for such findings. Firstly, the manual training was conducted in a virtual three dimensional environment while the mental rotation test is a two dimensional measure. Secondly, the mental rotation test required four figures for comparison unlike the training where only one figure was available for comparison. These issues may have reduced any potential effects of training in mental rotation.

## 1.9 Summary

- Spatial representation in vision is important for mis-oriented object recognition, navigation and interacting with our environment.
- One way the visual system represents spatial information is via reference frames which are based on coordinate system representations. These reference frames can undergo mental transformations such as mental rotation.
- Mental rotation and manual movement both activate premotor areas and concurrent tasks show interference effects.

- The link between movement planning (traditionally associated with premotor areas such as supplementary motor area; SMA) and mental movement remains undetermined.
- The aim of the thesis is to examine this link further. The next chapter discusses SMA, its functions and how they may extend beyond movement planning to computing mental rotation and motor planning.

## Chapter 2

### The Supplementary Motor Area

#### Chapter Overview

As discussed in the previous chapter, supplementary motor area activation has been observed during visuospatial transformation particularly in mental rotation. This chapter focuses on the supplementary motor areas to establish the nature of the regions involvement in visuospatial transformation.

The supplementary motor areas, on the medial surface of the superior frontal gyrus, are anatomically and functionally subdivided into caudal supplementary motor area proper (SMA) and rostral pre-supplementary motor area (pre-SMA). The supplementary motor areas are extensively connected to the basal ganglia. Unlike SMA proper, pre-SMA does not have direct connections to motor areas suggesting pre-SMA computes more abstract functions associated with movement (Nachev, Kennard, & Husain, 2008).

SMA and pre-SMA are functionally heterogeneous (Nachev, Kennard & Husain, 2008). Planning and preparation of movement, traditionally associated with supplementary motor areas, activate both SMA and pre-SMA for different functions (Goldberg, 1985; Tanji, 1994). While SMA is active during the movement onset of motor tasks, pre-SMA has more of a role in pre-movement activity (Alexander & Crutcher, 1990; Cunnington, Windischberger, Deeke, & Moser, 2002; Lee, Chang, & Roh, 1999; Matsuzaka et al., 1992; Picard & Strick, 1996; 2001; Rizzolatti et al., 1990; Shima, Mushaike, Saito, & Tanji, 1996; Shima & Tanji, 1998). Pre-SMA activity has also been observed in the planning and learning of sequential movements implying an association with complex movement planning (Shima, Mushiake, Saito, & Tanji, 1996). Another function associated with supplementary motor is internally and externally generated movement (Luppino, Matelli, Camarda, Gallese, & Rizzolatti, 1991; Matsuzaka, Aizawa, & Tanji, 1992; Musiake et al., 1991; Passingham, 1993; Picard & Strick, 1996; 2001). Pre-SMA is involved in early movement planning

and preparation while SMA modulates the later stages of movement execution as expected by its motor cortex connectivity (Luppino, Rozzi, Calzavara, & Matelli, 2003). Pre-SMA has been associated with conflict resolution between competing responses and selecting movement (Garavan, Ross, Kaufman, & Stein, 2003; Nachev, Rees, Parton, Kennard, & Husain, 2005; Ullsperger & von Cramon, 2001).

Visuospatial transformation has also been shown to elicit pre-SMA activation (Johnston et al., 2004). One explanation for such activity is that pre-SMA supports motor and non-motor processes by computing representations of movements in coordinate systems required for mapping reference points from one spatial location to another, vector transformation hypothesis (Leek & Johnston, 2009).

## 2.2 Anatomy and connectivity of supplementary motor areas

The supplementary motor areas are located on the medial surface of the superior frontal gyrus, anterior to the motor area and were originally demonstrated in monkey studies (Tanji, 1996). More recently, this region has been subdivided into the caudal SMA proper (SMA) and rostral pre-supplementary motor area (pre-SMA) with distinct connectivity as depicted in Figure 2.1 (Luppino et al., 1991; Matsuzaka et al., 1992, 1996; Picard & Strick, 1996, 2001).

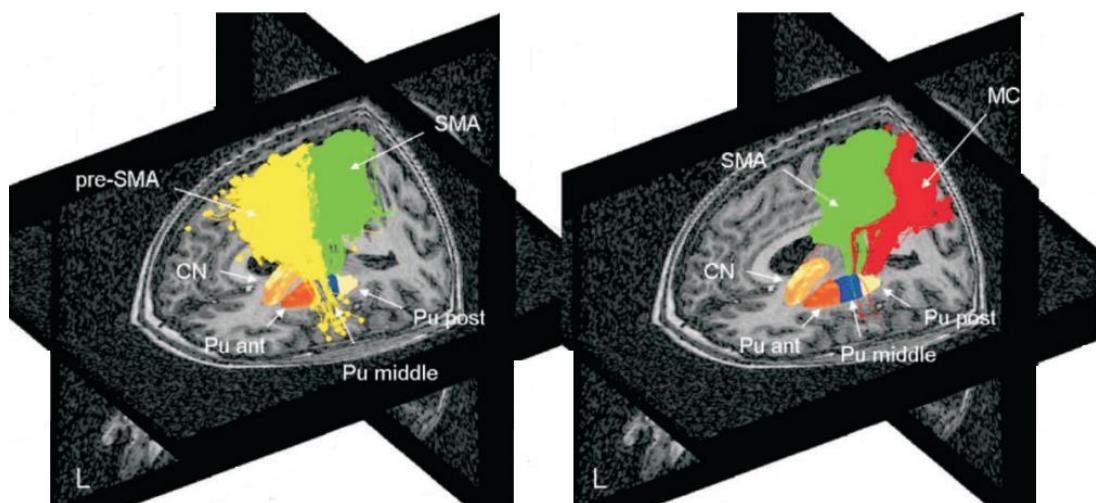

Figure 2.1. Caudal-rostral sub-divisions for SMA (F3) and pre-SMA (F6) with distinct connectivity to striatum. (Lehéricy et al. 2004). The figure on the left shows the comparison of tracks coming from the

**SMA (green) and pre-SMA (yellow). In the righthand figures, we see the comparison of tracks coming from the SMA (green) and motor cortex (red).**

SMA proper is extensively connected to motor regions of the cortex with direct connectivity to dorsal pre-motor cortex, primary motor cortex and the spinal cord (Luppino, Rozzi, Calzavara, & Matelli, 2003). While SMA has direct connections to motor effectors, pre-SMA connects to dorsolateral prefrontal cortex and non-motor regions (Lu, et al. 1994; Maier et al., 2002; Hoshi & Tanji, 2004), thus implicating it in more abstract cognition associated with movement (Geradardin, et al., 2000; Picard & Strick, 1996).

The supplementary motor areas also form part of the basal ganglia circuit. Akkal, Dum and Strick (2007) showed that the number of cells that project from the GPi to the SMA and pre-SMA via the thalamus is 3-4 times the number that project from the cerebellum highlighting the vital role of supplementary motor areas in this circuit. The pre-SMA sends efferents to the striatum which has direct and indirect projections to the GPi, thus completing a sub cortical loop (Inase, Tokuno, Nambu, & Akazawa, 1999). The SMA and pre-SMA have hyperdirect connections to the subthalamic nucleus (Nambu, Takada, Inase, & Tokuno, 1996). This route has been considered important for the rapid “brake” function of the supplementary motor area in the cortical basal ganglia circuit (Frank, Samanta & Moustafa, 2007).

The supplementary motor areas are only part of a more complex motor control network. The role of the motor circuit and supplementary motor areas may be investigated by examining activity in this area in a variety of movement related tasks as well as the result of damage to the SMA circuit as is the case with Parkinson’s disease and medial premotor lesions.

### **2.3 Functional heterogeneity of the supplementary motor areas**

Clinical reports of lesions to supplementary motor areas have suggested that pre-SMA and SMA are functionally as well as anatomically distinct (Nachev, Kennard, & Husain, 2008). While supplementary motor areas have traditionally been associated with the generation of voluntary

action (Lassen, Ingvar, & Skinhøj, 1978; Orgogozo, Larsen, Roland, & Lassen, 1979; Roland, Larsen, Lassen, Skinhøj, 1980), subsequent research into the precise function of the supplementary motor areas suggested that the region was associated with planning and preparation of movement, the composition of sequential movements, internally generated movement, and visuospatial transformation, (Goldberg, 1985; Tanji, 1994). The following discussions consider the precise contribution of pre-SMA and SMA proper to these proposed functions of supplementary motor areas; planning and preparation of movement, internally generated movement, movement selection and action control and visuospatial transformation.

### **2.3.1 Planning and preparation of movement**

Matsuzaka, Aizawa and Tanji, (1992) initially compared neuronal activity in SMA and pre-SMA. Pre-SMA neurons were found to be more involved in preparation rather than in the onset of preceding movements. Subsequent findings showed preferential activation of pre-SMA neurons when changing the direction of visually guided movement prior to movement execution (Matsuzaka & Tanji, 1996). Thus it can be argued that pre-SMA is involved in pre-movement activity associated with planning prior to movement execution.

The functional subdivisions of SMA have been further determined by the roles of the distinct regions in movement tasks. Subsequent research has shown that activation of SMA proper was predominantly observed during movement onset phases of motor tasks (Lee, Chang, & Roh, 1999; Picard & Strick, 1996; 2001) while pre-SMA activation is seen during the preparation stage prior to movement (Alexander & Crutcher, 1990; Rizzolatti et al., 1990; Matsuzaka et al., 1992; Shima, Mushaike, Saito, & Tanji, 1996; Shima & Tanji, 1998). These findings support the notion that SMA is functionally subdivided and that SMA proper may be more associated with movement execution whereas pre-SMA may play a more prominent role in the selection and preparation of movement. Regional cerebral blood flow (rCBF) changes in SMA during movement execution,

response selection and motor planning further support the concept that SMA is functionally distinct (Orgogozo & Larsen, 1979; Roland et al., 1980).

Picard and Strick (1996) identified that pre-SMA is activated by high order processes whereas SMA proper is associated with more simple motor behaviour. In support of these findings, pre-SMA activity has been found during the sequential learning of motor patterns (Hikosaka et al., 1996) and in the planning and formation of novel sequences (Shima, Mushiake, Saito, & Tanji, 1996) thus implicating pre-SMA in the planning or learning of sequential movements.

### **2.3.2 Internally vs. Externally generated movement**

Early research reported that SMA (mesial premotor area) is more involved in internally generated movement while the lateral premotor area is involved in externally cued movements (Goldberg, 1985). This mesial lateral dichotomy has been supported by anatomical studies in monkeys confirming the association of lateral premotor cortices with externally generated movement and SMA to internally generated movement (Luppino, Matelli, Camarda, Gallese, & Rizzolatti, 1991; Matsuzaka, Aizawa, & Tanji, 1992; Musiake et al., 1991; Passingham, 1993; Picard & Strick, 1996; 2001).

Consistent with this proposed function of mesial premotor cortex, regional cerebral blood flow (rCBF) and movement related potential studies have shown greater activation of SMA during internally generated tasks, where participants choose a pattern of responses, than externally generated tasks, when participants respond to visually guided cues (Deiber et al., 1991; Roland et al. 1980; Papa, Artieda, & Obeso, 1991). Additionally, animal research involving monkeys has shown that SMA lesions lead to disturbances in task execution in the absence of external cues, further supporting the specialised role of this region in internally guided movements (Thaler,



Chen, Nixon, Stern, & Passingham, 1995). However, these findings were reported prior to the now well documented subdivisions of supplementary motor areas.

With regards to functional heterogeneity, when participants are free to choose their actions without external cues, there is greater activity in pre-SMA (Jenkins, Jahanshahi, Jueptner, Passingham, & Brooks, 2000; Deiber, Honda, Ibanez, Sadato, & Hallett, 1999; Deiber et al. 1991). Prior to internally and externally generated actions, SMA proper shows similar patterns of activation. However, activation is observed earlier in the pre-SMA for internally than externally generated movements suggesting that pre-SMA is involved in early movement preparation processes prior to movement onset (Cunnington, Windischberger, Deeke, & Moser, 2002) while SMA proper is involved in the later stages of movement execution. Thus the supplementary motor areas are greater associated with movement planning and execution of internally generated movements than movements cued by external cues. These findings are also consistent with the role of SMA in movement planning and preparation and selection of movement.

### **2.3.3 Movement Selection and Action Control**

Pre-SMA has been implicated in a range of high level cognitive functions such as movement generation and recognition (Stephan et al., 1995); visuomotor associations (Sakai, et al., 1999), motor sequence learning (Nakamura, Sakai, & Hikosaka, 1999; Shima & Tanji, 2000; Isoda & Tanji, 2004); internally guided movement (Picard & Strick, 1996); movement selection (Dieber et al., 1991); representing action intention (Lau, Rogers, Haggard, & Passingham, 2004), resolving motor conflict (Ullsperger & von Cramon, 2001; Garavan, Ross, Kaufman, & Stein, 2003; Nachev, Rees, Parton, Kennard, & Husain, 2005) and task switching between motor actions (Matsuzaka & Tanji, 1996; Rushworth, Hadland, Paus, & Sipila, 2002; Kennerley, Sakai, & Rushworth, 2004). While there are many functions associated with pre-SMA, this may be because pre-SMA modulates a more basic process that underlies these functions or that in fact, pre-SMA is itself a functionally heterogeneous area. One such process could be in action control (Botvinick, Braver,

Barch, Carter, & Cohen, 2001), more specifically, the resolving of conflict between competing motor plans by selecting one motor action in favour of another. Evidence to support the function of pre-SMA in resolving conflicts between motor plans comes from a patient with a selective pre-SMA lesion with intact SMA who showed no deficit of simple reaction times but had a deficit inhibiting responses where there were competing responses demonstrating the role of pre-SMA in controlling voluntary actions (Nachev, Wydell, O'Neill, Husain, & Kennard, 2007). These findings are consistent with impairments of inhibitory processes observed in PD patients relative to controls during lexical decision tasks (Mari-Beffa, Hayes, Machado & Hindle, 2005). Interference from competing responses has been greater on Stroop tasks in patients relative to controls (Henik, Singh, Beckley & Rafal, 1993). The proposed function of pre-SMA in the resolving of conflict between competing responses can account for the impairment of these processes in PD via reduced pre-SMA activation consistently observed in this clinical population (Jahanshahi et al., 1995; Jenkins, Fernandez, Playford et al., 2004; Playford, Jenkins, Passingham, Nutt, Frackowiak, & Brooks, 1992; Rascol, Sabatini, Chollet, et al., 1994).

#### **2.3.4 Visuospatial transformation**

Supplementary motor area activity has been observed during the imagination of movement even if the movement is not executed (Roland et al., 1980) suggesting that SMA, as previously discussed, is involved in the preparation and encoding of actions prior to movement initiation whether or not actions are executed (Cunnington, Iansky, Bradshaw, & Philips, 1996; Cunnington, Windischberger, & Moser, 2005). Grezes and Decety (2002) observed that simply viewing a graspable object activates SMA and pre-SMA in humans regardless of whether or not the grasping action is carried out. Despite there being no actual movement generation, pre-SMA may be activated because the presence and processing of the graspable object may activate a motor plan in the brain. One account suggests that pre-SMA generates and encodes motor

representations in sustained activity prior to movement maintaining these representations in readiness for action (Passingham, 1996).

Similarly, fMRI and PET studies have demonstrated that pre-SMA, SMA, premotor, parietal and basal ganglia regions that are active during motor action are also active during motor imagery in the absence of physical movement execution (Gerardin et al., 2000; Grafton, Arbib, Fadiga, & Rizzolatti, 1996; Stephan et al., 1995). Thus it can be assumed that the same neural regions would be active during the execution and imagination of motor movement but only in the movement preparation stage (Jeannerod, 1995; Jeannerod & Frak, 1999; Grafton et al., 1996). While SMA is active when mentally imitating a movement sequence, pre-SMA activation is seen in the evaluation of these observed movements, during the mental simulation and observation of an action with the intention to reproduce the movement. This supports the role of pre-SMA in movement planning and preparation and further supports the functional subdivisions.

Several studies implicate SMA, dorsolateral prefrontal cortex and superior parietal cortex in high level cognitive imagery computations such as mental rotation (Johnston et al., 2004; Lamm, Windischberger, Leodolter, Moser, & Bauer, 2001; Richter et al. 2000; Tagaris et al., 1997; Vingerhoets et al. 2001), suggesting pre-SMA is involved in abstract visuospatial transformation. Imaging research has reported pre-SMA activity during two dimensional image rotations (Johnston et al. 2004; Leek & Johnston, 2009; Milivojevic, Hamm, & Corballis, 2009; Richter et al., 2000; Windischberger et al., 2003; Vingerhoets et al., 2001; Zacks, 2008) further implicating pre-SMA in visuospatial computation.

A growing body of research suggests that pre-SMA may support non-motor processes such as the mental transformations of images in space, as seen in Figure 2.2 (Johnston et al., 2004; Richter et al., 2000; Windischberger et al., 2003). This leads us to question what the link is between movement planning and abstract visuospatial transformation. The imagined motor simulation

from visuospatial transformation tasks such as mental rotation may rely on vector transformation (Leek & Johnston, 2009).



**Figure 2.2** Activation of anterior part of medial premotor cortex (pre-supplementary motor area) during abstract mental rotation of 2D novel shape representations. This activation provides evidence that pre-SMA is involved in the computation of visuospatial transformations (Johnston et al. 2004).

## 2.4 The Vector Transformation Hypothesis

Neuronal activity associated with effector dependent reaching was most frequently observed in pre-SMA than in SMA (Fuji, Mushiake, & Tanji, 2002) and pre-SMA neurons preferentially represented the location of a reaching target which suggests that pre-SMA participates in the representation of visually guided movement in a reference frame (Hoshi & Tanji, 2004). Considered together, these findings suggest that one function of pre-SMA is to compute the coordinates of locations in space.

The vector transformation hypothesis (Leek & Johnston, 2009) proposes that one function of the pre-SMA is the computation of transformations required to map one set of spatial coordinates to another within a reference frame via a transformation matrix. Thus, the pre-SMA does not support movement through dedicated motor planning operations, but rather through the use of abstract spatial vector transformations which are used in both motor and non-motor tasks requiring the remapping of spatial locations in abstract space.

These computations are presumed to underlie a variety of tasks including the planning and online control of visually guided movement via the calculation of movement trajectories during the planning, and online control, of action, as well as abstract cognitive tasks like mental rotation, and object recognition, where image normalisation is required. These vector transformation computations are used in both motor and non-motor tasks that require spatial remapping by adding and subtracting numerical values that specify spatial locations.

## 2.5 Summary

- The supplementary motor area is on the medial surface of the superior frontal gyrus in humans.
- The region is functionally and anatomically subdivided into SMA proper and pre-SMA.
- Functions associated with SMA proper include movement onset of motor tasks and the later stages of movement execution of internally generated movement.
- Functions associated with pre-SMA include early movement planning and preparation, the learning and planning of sequential movements, response and movement selection and visuospatial vector remapping.
- The vector transformation hypothesis (Leek & Johnston, 2009) proposes that one function of the pre-SMA is the computation of transformations required to map one set of spatial coordinates to another.

## **Chapter 3**

### **Parkinson's disease**

#### **Chapter Overview**

The previous chapter considered the function of supplementary motor areas and the anatomical distinction between pre-supplementary motor area (pre-SMA) and SMA proper. Also examined was evidence supporting the hypothesis that one function of pre-SMA is in the computation of spatial vector remappings – the vector transformation hypothesis. This chapter discusses how Parkinson's disease (PD) may be used as a model of pre-SMA dysfunction in order to test the predictions of the vector transformation hypothesis.

An overview of PD is provided beginning with the basal ganglia circuit and its connectivity because the basal ganglia play a central role in the pathology of PD. The pathology of PD is then discussed with regards to disruption to the basal ganglia circuit. The cardinal motor symptoms of PD are described followed by the cognitive impairments associated with PD, namely language processing difficulties, executive functions, and visuospatial cognition including mental rotation and visuospatial working memory. The nature of the visuospatial deficit in PD is discussed with regards to the frontal basal ganglia neural networks, executive function and vector transformation.

#### **3.1 The basal ganglia circuit**

The basal ganglia consist of the caudate nucleus, putamen and the globus pallidus. The three large nuclear masses underlie the cortical mantle, and the functionally related sub-thalamic nucleus, substantia-nigra and red nucleus are on either side. The interconnections of these nuclei are complex. On each side there is extensive projection from the motor cortex, the supinator strip and the premotor cortex to the striatum. The striatum projects to the substantia-nigra and to the globus pallidus. The ansa lenticularis is the major efferent pathway to the ventro lateral and ventral anterior nuclei of the thalamus, the subthalamic nucleus, the red nucleus and other areas of

the brain stem. Thalamic nuclei project to the motor areas in the cortex (the same areas that project to the striatum), thus completing a closed feedback loop (Middleton & Strick, 2000).

The nigro-striatal dopaminergic system is a prominent system of dopaminergic neurons. The system contains cell bodies in the substantia-nigra and axonal endings in the caudate nucleus. The dopamine released at these endings, appears to inhibit cells in the caudate, whereas acetylcholine released from other cells excites them. A feedback circuit from the caudate to the substantia-nigra is made up of neurons that secrete GABA. The subthalamic nucleus has reciprocal connections to the globus pallidus (Alexander, DeLong, & Strick, 1986; DeLong & Wichmann, 2007). The red nucleus receives input from the other basal ganglia, the cerebral cortex and the cerebellum; it projects, diffusely, to the reticular formation and spinal end (DeLong & Wichmann, 2007).

### **3.2 The pathology of Parkinson's disease**

Problems in the basal ganglia circuitry underlie PD. In PD, the nigrostriatal system of dopaminergic neurons is damaged (Jankovic, 2008; Olanow & Tatton, 1999). A loss of dopamine producing cells causes deregulation in the striatum, resulting in dysfunctional multiple circuits which connect the basal ganglia with motor areas and cognitive cortical regions (Middleton & Strick, 2000).

Figure 3.1 illustrates the complex circuitry between the cortex, striatum, subthalamic nucleus and the thalamus. The arrows depict the direction of the pathway and the colours show the neurotransmitters involved. The excitatory pulses are marked with a positive sign and the inhibitory impulses are marked with a negative sign. The dopaminergic pathways and the excitatory glutamate pathways are of particular interest when investigating pathological changes of the basal ganglia motor circuit in Parkinson's disease.

Figure 3.2 shows the changes to the pathologic functional anatomy of the basal ganglia motor circuit in PD. These can be summarised as reduced dopaminergic impulses from the

substantia nigra to the striatum, enhanced excitation of the subthalamic nucleus and the globus pallidus internus and increased inhibition of the thalamus.



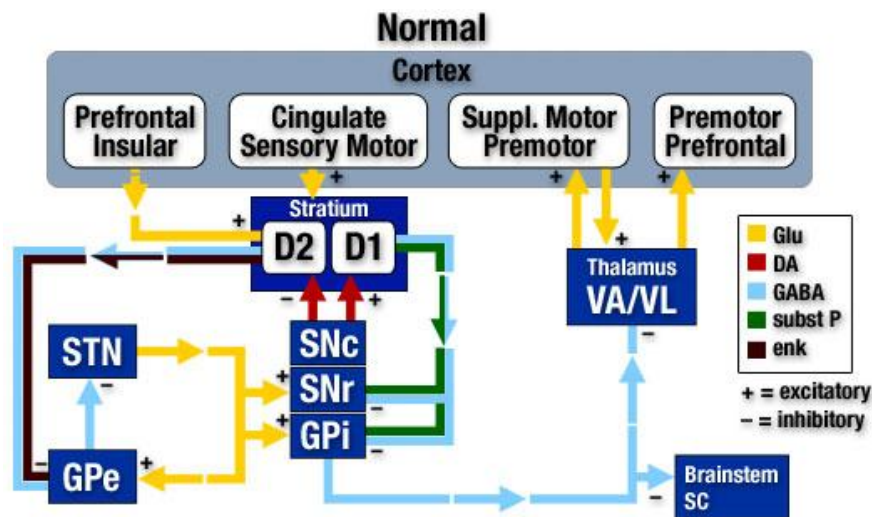

Figure 3.1. Normal functional anatomy of the basal ganglia. The arrows point in the direction of different tracts and the colors indicated on the right show the neurotransmitters involved at each level. The positive sign near the end of the tract indicates that the impulses are excitatory, while the negative sign indicates inhibitory impulses. For reference, keep in mind the width of these tracks is proportional to the strength of the signal. Of special interest are the dopaminergic pathways and the excitatory glutamatergic pathways. Retrieved from: [http://www.mdvu.org/library/disease/pd/par\\_path.asp](http://www.mdvu.org/library/disease/pd/par_path.asp)

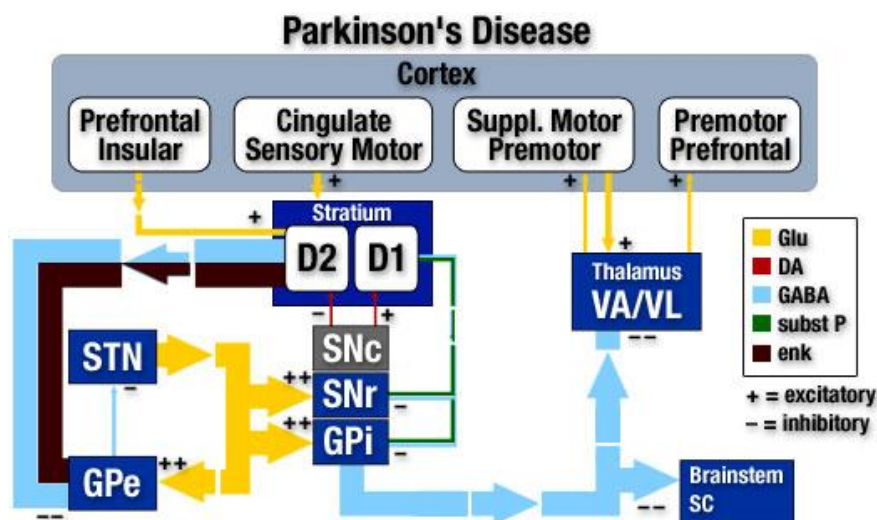

Figure 3.2. Pathologic functional anatomy of the basal ganglia in Parkinson's disease. This second diagram shows the changes in the basal ganglia cortical circuitry after substantia nigra compacta damage. The main features are the reduced dopaminergic impulses from substantia nigra to the striatum, enhanced excitation of the subthalamic nucleus and the globus pallidus internus, and increased inhibition of the thalamus. Retrieved from: [http://www.mdvu.org/library/disease/pd/par\\_path.asp](http://www.mdvu.org/library/disease/pd/par_path.asp)

PD is characterised by a severe loss of neurons in the substantia nigra. When the initial signs and symptoms of PD begin to present, it is estimated that up to 60-70% of the substantia nigra dopaminergic neurons are lost. Neuroimaging research shows that the loss of dopamine

terminals in the striatum is synaptically asymmetrical and exacerbates over time leading to further clinical deterioration (Kempster, Gibb, Stern, & Lees, 1989).

### 3.3 Symptoms

As there is no specific test or biomarker for PD, diagnosis is based on the presence of 2 of the 4 cardinal motor signs of PD: resting tremor, bradykinesia, rigidity, and/or postural instability.

Tremor is experienced by approximately 70% of PD patients either in the hand or foot on one side of the body (Hoehn & Yahr, 1967). Tremor is a rhythmic movement that cannot be controlled and usually appears when muscles are relaxed and so is called a resting tremor. Though the tremor progresses to other parts of the body as the disease advances, it remains most severe in the region of onset throughout disease progression.

Bradykinesia is the slowness of movement which can also manifest in impaired movement control. This can lead to incomplete movements and difficulties in initiating and terminating movements. Bradykinesia may also cause people to walk with a shuffling gait which is most apparent during turning. Slowness of movement and rigidity can occur in facial muscles. Whereas tremor and bradykinesia are commonly reported symptoms, rigidity is less commonly reported by patients and is often referred to as muscle stiffness.

Rigidity is recognised if there is increased resistance throughout the range of motion. In rigidity, muscle tone on an affected limb is stiff and does not relax which results in a decreased range of movement. The assessment of rigidity involves passive movements of the neck, lower limbs and upper limbs.

Another clinical hallmark of PD, which typically emerges later in the course of the disease is postural instability. Postural instability is assessed by the “pull test” whereby the patient stands behind the patients and the patient is asked to maintain their balance while the examiner pulls the

patient back briskly. The patients' ability to recover is assessed. With the progression of the disease, postural instability is accompanied with abnormal gait.

### **3.4 Cognitive Impairment in Parkinson's disease**

Though PD is most commonly associated with the hallmark motor symptoms, the cognitive symptoms associated with PD have recently received more attention. Cognitive domains likely to be impaired in PD include language (Altmann & Troche, 2011), executive function (Cools, van den Berken, Horstink, van Spaendonck, & Berger, 1984; Cronin-Golomb & Braun, 1997) visuoperceptual and visuospatial ability (Crucian et al., 2003; Lee, et al., 1998; Sawamoto, Honda, Hanakawa, Fukuyama, & Shibasaki, 2002). Disrupted basal ganglia output can disrupt frontal lobe function. As such, cognitive processes which require frontal lobe functions such as abstract thinking and reasoning, attention, organisation and planning, and memory are likely to be affected in PD. These will be discussed further now.

The pathology of PD, with its effects of subcortical structures such as the thalamus and basal ganglia, suggests impairments of language processing and given that PD is progressive and degenerative, it can be assumed that language impairments observed in PD will be related to disease progression. A review of the literature on language production in PD details the production processes which are impaired in this condition concluding that PD affects language production in all stages from message generation, syntactic organisation and articulation (Altmann & Troche, 2011). Initial research into language disorders in PD identified impairments in the more advanced stages of PD. These studies however, focussed on examining basic language ability e.g. confrontation naming, word and short sentence comprehension (Bayles et al., 1997; Cummings, Darkins, Mendez, Hill, & Benson, 1988). More recent methods investigating higher level aspects of language processing found linguistic impairments across the range of stages of PD (Zanini et al., 2003). Many of the linguistic impairments observed in PD patients may be a result of disruption to more general cognitive processes such as executive function impairment.

Executive function is an umbrella term for cognitive processes such as planning, working memory, attention, problem solving, verbal reasoning, inhibition, mental flexibility, multi-tasking, initiating and monitoring actions (Lezak, 1982). They refer to a range of cognitive behaviours and processes that govern the ability to selectively attend to, manipulate, and plan for specific information (Elliot, 2003; Lezak, 1982). Given the involvement of executive functions in selecting, holding and manipulating information, these cognitive processes are commonly associated with planning and organisation. Executive functions also encompass cognitive flexibility required in processes such as set shifting (Cools, van den Berken, Horstink, van Spaendonck, & Berger, 1984) and inhibiting irrelevant information (Witt et al., 2006) or inappropriate behaviours. They control the initiation and termination of actions and monitor behaviour adapting or changing behaviour as necessary (Lee et al., 2010).

Executive functions are primarily mediated by the prefrontal regions of the frontal lobes (Alvarez & Emory, 2006). These areas have multiple connections with other cortical regions including dorsolateral prefrontal cortex, associated with the online processing of information and more specifically verbal fluency, set shifting, planning, response inhibition, working memory, abstract thinking and reasoning, problem solving and organisation, all facets of executive function (Alvarez & Emory, 2006; Cronin-Golomb & Braun, 1997).

The neuropathology of PD suggests that the magnitude of any cognitive deficits will reflect the degree to which the task relies on the integrity of the frontal executive system (Taylor & Saint-Cyr, 1995). Dopamine depletion in the caudate nucleus is thought to cause frontostriatal disruption which may manifest in impaired executive functions implicating dopamine regulation in the successful execution of executive functions (Cools, Stefanova, Barker, Robbins, & Owen, 2002; Owen, 2004, Zgaljardic, Borod, Foldi, & Mattis, 2003). Further support for this comes from L-dopa withdrawal negatively affecting executive function in PD (Lange, et al., 1992).

Theories of cognitive deficits in PD focus around PD patients demonstrating impaired performance on tasks requiring high task demands such as applying the cognitive flexibility to updating information to adapt plans or set shifting and forward planning or strategy formulation (Bondi & Kasniak, 1991; Brown & Marsden, 1990). For successful planning to take place, individuals must look ahead through a series of possible steps, (some of which may be counter intuitive) to reach a desired goal. This ability to plan is essential to daily living and deficits have been reported in PD from the early stages of disease onset (Culbertson, Moberg, Duda, Stern, & Weintraub, 2004; Hodgson, Tiesman, Owen, & Kennard, 2002).

Findings by McKinlay et al. (2008) suggest that planning deficits in PD are dependent on the cognitive demands of the task and that patients are able to complete tasks such as the Tower of London (Shallice, 1982), under conditions where a solution strategy can be inferred from the instructions given but not when required to devise a strategy thus supporting the idea that PD patients have a deficit in generating strategies on several cognitive tasks (Cohen, Boucher, Scherzer, & Whitaker, 1994; Farina et al., 1994; Price, 2006; Swainson et al., 2006). These factors may contribute to the problem solving deficit in PD patients. Though it appears to be the most profound cognitive impairment in PD, the exact pattern of executive function impairment remains undetermined. Additionally, the complex nature of executive functions suggests that they may underlie high level cognitive processes such as visuospatial cognition.

### **3.5 Visuospatial cognition impairments in Parkinson's disease**

Visuospatial impairment in PD is among the more controversial questions surrounding cognitive changes in the condition. Spatial impairments have been identified in PD patients throughout the progression of the disease and are independent from motor symptoms (Chaudri & Schapira, 2009; Hovestadt, deJong & Meerwaldt, 1987). Visuospatial processing in PD has since been investigated from a number of perspectives; impairments have been identified in space perception, mental rotation, navigation and spatial working memory.

The earliest evidence for a spatial deficit was observed in the lower WAIS score on performance subsets, than on verbal subsets (Brown & Marsden, 1986). However, this may have been because the performance subsets are scored based on speed of completion. PD patients experience motor slowing and impaired manual dexterity which may have accounted for the finding. Though PD has been associated with deficits in visuospatial tasks, the literature demonstrating a deficit is inconsistent. While PD patients have shown impairments on standardised tasks such as the WAIS, performance on other tasks such as embedded figures and line orientation tasks remains within the normal range (Levin, Llabre & Weiner, 1991). It can be argued that tasks such as block design and object assembly that make up many standardised measures are cognitively complex and require a number of cognitive processes beyond visuospatial ability. Deficits in these areas may reflect disturbances to underlying cognitive processes and thus may not reflect a true account of visuospatial function. (Levin, Llabre & Weiner, 1991) Furthermore, visuospatial ability is not likely to be a distinct cognitive process (Stelmach, Phillips & Chau, 1989). As a result, PD patients may show impairments on some visuospatial tasks and not others.

On a maze navigation task, participants navigated around a maze without a map and remembered the route to a target location (Leplow et al., 2002). However, when participants were relocated to a start location 90° deviant from the original start location, PD patients were unable to adapt their plans to accommodate the change and reorient themselves, suggesting that PD patients have a deficit with rapidly acquiring new spatial environments.

This deficit could be the result of an impairment of personal orientation awareness, that is, an impaired ability to perceive the self in an abstract environment (Bowen, Burns, Brady, & Yahr, 1976). On a navigation task which required participants to invert their body image to interpret a map, PD patients confused left and right turns when inverting body positions, implying difficulty executing perceptual body position transformations. These findings are consistent with findings of

impaired route finding and navigation in PD ( Uc, Rizzo, Anderson, Sparks, Rodnitzky & Dawson, 2007).

These impairments may lie in the nature of the tasks measuring visuospatial function. The perception of space is complex and it is difficult to associate the influence of spatial intelligence, praxic intelligence and memory factors on visuospatial performance. A more definite rationale for impairment can be obtained by using elementary tasks which test the more basic mechanisms underlying spatial perception. Visuospatial orientation is believed to be the most basic component of visuospatial ability (Linn & Petersen, 1985; McGee, 1979; Bryden, 1982, Stumpf & Eliot, 1999). Mental rotation is a phenomenon which involves visuospatial ability to manipulate a mental image to match the orientation of another.

### **3.5.1 Mental Rotation in Parkinson's disease**

Mental rotation tasks require visuospatial orientation. As one of the most basic components of visuospatial ability, mental rotation tasks offer a reliable measure of visuospatial ability in PD. Visuospatial ability measured by mental rotation in PD remains equivocal. While some studies report impairment, others find no such deficit. The inconsistencies in the research findings may be because different stimulus types engage different cognitive operations on mental rotation tasks.

A mental rotation task was administered to PD patients by Brown and Marsden (1986). A central fixation cross was presented and was followed by an arrow facing in a particular direction. There was a dot on either the left or right of the arrow if they mentally aligned themselves with the arrow. Findings showed that although PD patients were slower than normal controls, they were not worse on conditions that required a greater degree of reorientation. The authors concluded that the findings did not suggest a PD impairment of mental manipulation or a visuo-spatial impairment. However, it cannot be determined whether participants were aligning themselves to the arrow or whether they were rotating the stimuli to an upright position for an image based judgement to be made. Consistent with literature on visuospatial impairment in PD, it has been

argued that the impairment was due to participants changing the relationship between themselves and the stimulus. As such the task may not have been a strong enough test of mental rotation. A greater or stronger test would require participants to change the relationship between two stimuli.

This was investigated in a task by Lee et al., (1998) who adapted Shepard and Metzler's (1971) original mental rotation task. Participants made same/different judgements of two figures which were presented at varying orientations. Participants could not mentally reorient themselves in relation to the stimuli, but instead had to re-orientate one stimulus item with regards to the other. Apart from slower reaction times for PD patients compared with controls, no significant differences were found compared with controls on 2D stimuli. PD patients were significantly slower at responding to 2D drawings of 3D objects and made significantly more errors than the control group. These errors were systematic to large angular differences and suggested a visuospatial deficit in PD patients on the basis of impaired perception of extra personal space (Lee et al., 1998). Patients may have been relying too much on a local feature matching strategy instead of a more global matching strategy, thus not performing mental rotation (Lee et al., 1998). Unlike with 2D stimuli, local feature matching strategies are not sufficient to complete mental rotation judgements of 3D stimuli. However, the rotation of 3D stimuli does introduce various sources of variability such as foreshortening and feature occlusions which complicate the depth rotation of 3D stimuli. The scope for change in the geometric shape information is eliminated in 2D stimuli making the 2D image plane a more reliable means of studying the effects of mental rotation because there are no changes made to the geometric shape information in the visual input. In mental rotation, the visual input is held in working memory where it is manipulated to meet the demands of the task. Therefore, impairments may be due to visuospatial working memory impairment.



### 3.5.2 Visuospatial Working Memory

A cognitive theory of dysfunction in PD suggests that the visuospatial impairments are associated with a disturbance of the frontal basal ganglia neural circuits, important for higher level functions such as attention and concentration, sequencing, working memory and set-shifting (Brown & Marsden, 1990; Taylor & Saint-Cyr, 1995). Dysfunction of frontal striatal or frontal parietal systems, which are associated with dopamine deficiencies, may disrupt cognitive processes supporting working memory or visuospatial computations (Crucian et al., 2003) With this in mind, Crucian et al., (2003) proposed that a deficit in object imagery may account for impairments reported in mental rotation research with PD patients. To perform mental rotation, an individual must first perceive the target stimulus and store this perception in working memory as a mental image or internal representation. They must then transform the stored image into different spatial view-points to decide whether or not the image matches the choices. Abnormal performance on mental rotation tasks may be a result of a failure to perform and maintain the internal representation of the images in working memory.

An investigation into visuospatial impairments in PD tested the hypothesis that the locus of impairment is the visuospatial subsystem of working memory (Bradley et al., 1989). The tasks required all three working memory subsystems, central executive system – controls and coordinates other subsystems, articulatory loop – stores auditory speed and sub vocalisations and the visuospatial sketchpad – maintains and manipulates visuospatial material. Participants performed two tasks: a complex visuospatial memory task where they had to reproduce a pattern of shaded boxes increasing in complexity with each level and a complex verbal memory task where they had to memorise a phrase and then make judgements about which letters the words in the phrase started with e.g. “Did any of the words start with the letter “W”. No significant differences were found in reaction times (RTs) between the PD patients and the controls on the verbal memory tasks. However, the PD group was significantly slower than controls on the

visuospatial memory task. The findings suggest that an impairment of the visuospatial subsystem of working memory do exist in PD. Given that no between group differences were observed in the verbal memory task, it is implied that the impairment is not a result of a reduced capacity of the articulatory loop, but a difficulty in utilising information stored within visuospatial sketchpad to perform complex visuospatial tasks.

To test the function of the central executive Fournet, Moreaud, Roulin and Pellat (2000) manipulated the retention interval of information in a series of span tasks. Participants were tested on verbal and spatial span tasks and a double span task to elucidate the working memory deficit in PD. PD patients were found to show impairments compared to healthy controls on the spatial memory task. However, the task was measuring short term memory rather than working memory because no processing of stored information was required. The findings suggest that the spatial task was more sensitive to the length of retention interval. The authors concluded that this was due to more central attentional resources (Baddeley, 1986; Logie & Marchetti, 1991; Logie, Zucco, & Baddeley, 1990; Parr, 1992). As the delay between encoding and recall lengthens, the efficacy of the subsystem decreases. PD patients and controls showed the same pattern of results suggesting that PD patients do not have visuospatial sketchpad impairment. The short term memory impairment in medicated PD patients could be the result of a general slowing of information processing (Revonsuo, Portin, Koivikko, Rinne, & Rinne, 1993). Thus the precise nature of the contribution of working memory in PD remains unknown.

### **3.6 What accounts for the visuospatial deficit in PD?**

It has been established that PD patients have a deficit in visuospatial cognition. This has been demonstrated in a variety of tasks as previously discussed. The precise nature of the deficit remains unclear.

One explanation concerns the disrupted function of frontal basal ganglia neural networks that include areas associated with spatial abilities such as posterior parietal cortex (Cronin-

Golomb & Amick, 2001; Middleton & Strick, 2000; Fimm et al., 2001; Karnath, Himmelbach, & Rorden, 2002). These circuits have been identified as important for executive functions which often underlie the tasks investigating visuospatial ability in PD (Cools, van den Berken, Horstink, van Spaendonck, & Berger, 1984; Witt et al., 2006; Lee et al., 2010). Such tasks of visuospatial ability may involve several distinct cognitive processes (Ekstrom, French, Harman, & Dermen, 1976), and can be considered quite complex involving multiple cognitive processes. Visuospatial tasks often depend on many other cognitive processes including executive functions and this is a problem with the literature in this field.

When researchers controlled for executive dysfunction, visuospatial processing deficits were eliminated. But when controlling for visuospatial processing deficits, executive dysfunction remained, suggesting a significant relationship between executive dysfunction and visuospatial deficits (Bondi et al., 1993). Further support for this explanation comes from patients with frontal lobe lesions or PD showing difficulties in establishing and maintaining links between stimuli and their location (Petrides, 1985; Taylor, Saint-Cyr, & Lang, 1990).

Cronin-Golomb and Braun (1997) challenged the claim that in PD, dysexecutive and visuospatial abilities are associated. Non-demented, non-depressed PD patients were compared with controls on performance on Subtest A of Ravens Matrices with the other portions of the Ravens Matrices. Subtest A has greater visuospatial demands while the remaining subtests are more concerned with executive functions. PD patient performance on subtest A was related to performance on other measures of visuospatial ability (e.g. Lurias Mental Rotation Test, Standardised Road Map Test) but not executive function measures, suggesting that PD is associated with a more specific visuospatial problem solving deficit.

Thus it appears the altered function of frontal basal ganglia circuits underlie a visuospatial deficit in PD. These findings support the contribution of SMA to visuospatial transformation via

reduced thalamocortical projections to SMA. This thesis investigates this relationship further with the vector transformation hypothesis.

The vector transformation hypothesis assumes that a functional link between the pre-SMA and spatial transformation can be understood in terms of the neural implementation of basic mathematical computations underlying spatial vector transformation, in mapping spatial coordinates from one location to another within or between spatial coordinate systems (Johnston & Leek, 2009). PD has consistently been associated with under activity of the anterior SMA or pre-SMA (Fukuda et al., 2001; Sabatini et al., 2000; Thobias et al., 2000; Cunnington et al., 2001) thought to be the result of the selective loss of dopaminergic nigral input to the putamen which increases inhibition of the excitatory drive from the thalamus (Cunnington et al., 2001; Braak, et al., 1996). The pre-SMA receives input from the prefrontal cortex and projects to the cortical and spinal motor pathways via the SMA (Luppino, Matelli, Camarda, & Rizzolatti, 1993). Cortical regions corresponding to SMA and pre-SMA have distinct connectivity with the striatum (Lehericy, et al., 2004; Parthasarathy, Schall, & Graybiel., 1992). The reduced projections to supplementary motor areas including pre-SMA in PD are likely to affect visuospatial coordinate remapping systems executed by pre-SMA accounting for the impairments in visuospatial transformation tasks.

### **3.7 Summary**

- PD is a neurodegenerative disorder resulting from dopamine depletion in the basal ganglia.
- The cardinal signs of PD are motor symptoms of tremor, bradykinesia, rigidity and postural instability. The cognitive effects of PD have recently become the subject of extensive research.
- These cognitive impairments include language processing, executive function deficits, and visuospatial cognition.

- Findings of visuospatial transformation impairments in PD remain equivocal; while some researchers report deficits, others report normal performance on such tasks.
- PD provides a model of pre-SMA dysfunction and a means to test the vector transformation hypothesis.

## **Chapter 4**

### **Study I: An investigation of mental rotation impairment in Parkinson's disease**

#### **Chapter Overview**

This chapter investigates mental rotation in Parkinson's disease (PD) patients. PD has been associated with mental rotation deficits but the processes underlying the deficit remain undetermined. Visuospatial processing impairments have been observed in a variety of tasks including mental rotation, a phenomenon described in Chapters 1 and 3. Mental rotation requires several processes including spatial normalisation.

As PD is associated with cognitive slowing, it is of interest how this slowing will impact spatial normalisation. Spatial normalisation reflects the computation of spatial vector mapping between object features and their spatial locations. PD impairments of vector transformation underlying spatial normalisation are likely to manifest behaviourally in slower spatial normalisation rates or steeper regression times.

Study I investigated whether visuospatial transformation impairments in PD are related to spatial normalisation and how spatial normalisation affects mental rotation and orientation invariant object recognition. Controls and PD patient performance was compared on two tasks: (1) Perceptual Matching and (2) Recognition Memory. On Task 1, participants made same/different judgements about two simultaneously presented stimuli. On Task 2, participants initially memorised a target object at a specific orientation and then made target/non-target judgements to targets or visually similar distracters presented at variable orientations.

Analyses of regression slopes showed that PD is associated with impairments affecting spatial transformation during image normalisation in both tasks. PD patients were also more impaired at spatial transformation during the perceptual matching of two images than in the recognition memory task. The data from this chapter have been published and can be seen in Appendix A.

## Introduction

PD deficits in visuo-spatial processing have been investigated using a range of different psychometric paradigms, including variants of the classic Shepard and Metzler (1971) 'mental rotation' task. In this task, participants make shape equivalence or mirror image judgements about visual patterns across changes in image orientation or angular disparity. In normal observers – under certain conditions, response latencies are longer at larger angular disparities between stimulus pairs than at shorter ones (Cooper, 1975, 1976; Cooper & Shepard, 1978; Shepard & Metzler, 1971). It has been reported in some studies that PD patients show abnormal performance in the form of longer reaction times or decreased accuracy on these kinds of tasks (Crucian et al., 2003; Lee, et al., 1998; Sawamoto, Honda, Hanakawa, Fukuyama, & Shibasaki, 2002). However, the ability to judge the shape equivalence of objects across changes in stimulus orientation involves several distinct cognitive operations. These include the perceptual encoding of display elements, their maintenance in working memory, the spatial transformation, alignment or normalisation of image features, matching of perceptual representations and response selection. Thus, the specific functional deficit that underlies difficulties in visuo-spatial tasks in PD remains unclear – and this issue is further highlighted by the fact that visuo-spatial deficits in PD are not always found (Amick, Schendan, Ganis, & Cronin-Golomb, 2006; Boller et al., 1984; Duncombe, Bradshaw, Ianssek, & Philips, 1994; Raskin, Tweedy, & Borod, 1990).

In relation to this issue it is relevant to consider how a specific deficit to a spatial transformation process might be manifest behaviourally. Other studies have reported that one of the key underlying cognitive effects of PD is bradyphrenia; that is, a hypothesised general slowing of cognitive processing (e.g., Rogers, Lees, Smith, Trimble, & Stern, 1987; Sawamoto et al., 2002). So what effect would a generalised cognitive slowing have on spatial normalisation? This depends, in part, on how the spatial normalisation process itself is conceptualised. One hypothesis is that mental rotation or spatial normalisation reflects the computation of mappings of spatial

vectors between stimulus locations (e.g., Leek & Johnston, 2009; Johnston et al., 2004). At the neurophysiological level, such a process has been identified in terms of the neuronal population vector (Georgopoulos & Pellizzer, 1995; Pellizzer & Georgopoulos, 1993). For example, one might assume a hypothetical normal spatial normalisation rate of 2ms/deg. That is, it takes 2ms to compute the mapping between spatial vectors for each 1 degree of angular disparity. On this basis, it would take 120ms to compute the mapping across a 60 degree disparity, and 240ms across 120 degrees. A deficit resulting in a 50% reduction (i.e., from 2ms/deg to 3ms/deg) in the speed of cognitive processing (i.e., the rate at which the remapping is computed) would result in an increase in the time taken to compute a mapping over 60 degrees from 120ms to 180ms, and over 120 degrees from 240ms to 360ms. In other words, critically, a deficit to the speed of computation affecting this vector mapping process is predicted to manifest specifically in the slope of the regression line or spatial normalisation rate in mental rotation tasks. If the underlying visuo-spatial deficit in PD specifically affects this mapping process, it should be possible to empirically demonstrate its effects on the normalisation rate.

Another relevant issue concerns the generality of deficits to spatial transformation in PD processes across tasks. This question is motivated, in part, by other research showing dissociations between the processes underlying viewpoint costs in mental rotation and object recognition in neurologically normal subjects (De Caro & Reeves, 2000; Gauthier et al., 2002; Hayward, Zhou, Gauthier & Harris, 2006; Willems & Wagemans, 2001). For example, Hayward et al (2006) compared the response time functions associated with viewpoint costs in mental rotation and misoriented object recognition tasks. The results showed that spatial transformation times increase linearly with angular disparity in mental rotation, but only over small rotations in object recognition. Gauthier et al., (2002) contrasted BOLD activity in mental rotation and object recognition and found dissociable patterns of neural activation, supporting the hypothesis that spatial transformation processes in mental rotation and misoriented object recognition are



subserved by distinct cognitive and neural mechanisms. Further supporting evidence from neuropsychology has come from observations of a double dissociation between object recognition and mental rotation (Harris, Harris, & Caine, 2002; Turnbull & McCarthy, 1996). On the basis of this evidence one might expect a similar pattern of dissociation in PD.

The aims of Study I were to examine whether (1) visuo-spatial impairment in PD is specifically related to a spatial transformation process, and (2) impairments in spatial normalisation generalise across tasks of mental rotation and misoriented object recognition. This was assessed by contrasting spatial transformation processes in PD patients and age-matched, neurologically normal, controls across two tasks. Task 1 involved the simultaneous presentation of two abstract two dimensional (2D) patterns at either the same or different orientations. Participants had to determine whether the two images were the same or different shapes. This task is similar to the classic mental rotation perceptual matching paradigm that has been used in a number of previous studies of PD (e.g., Lee et al., 1998; Amick et al., 2006; Crucian et al., 2003). Task 2 used a recognition memory paradigm that, unlike Task 1, required the matching of a previously learned shape to long-term memory – similar to the demands of object recognition. Participants initially memorised a single 2D abstract shape at a single orientation. Following this they completed a recognition memory task in which a single target or visually similar distracter was presented on each trial at varying orientations. The task was to make a target/non-target judgement. This allowed us to examine the generality of any deficit in spatial mapping across tasks. In both tasks responses were measured using voice-onset time (VOT) as the dependent measure in order to avoid confounds related to motor slowing in PD.

## Methods

### Participants

Thirteen normally medicated non-dementing patients with idiopathic Parkinson's disease (4 Females, 9 Males, Mean age=66.08 years,  $SD=5.42$ , H&Y  $M=2.29$ ,  $SD=.72$ ; UPDRS<sup>1</sup>  $M=27.5$ ,  $SD=11.91$  tremor dominant  $N=4$ , akinetic rigid  $N=5$ , mixed  $N=4$ ), and 14 neurologically healthy controls (6 Females, 8 Males, Mean age=65.1 years,  $SD=4.9$ ) took part. Patients were recruited from a local PD clinic. Research was approved by the NHS and University ethics committees in accordance with the Declaration of Helsinki. Written informed consent was obtained before testing.

### *Assessment of motor impairment*

PD patients were classified as being at stages 2-3 of motor disability as measured by the Hoehn and Yahr Scale (Hoehn & Yahr, 1967). They were assessed with the Unified Parkinson's Disease Rating Scale (UPDRS; Part II: Activities of daily living, Part III: Motor examination) in the 'on' medication state and the scores from the two subscales were summed to give a total UPDRS score representing functional status and motor impairment (Scores out of 108).

### *Neuropsychological Background Assessment*

The Geriatric Depression Scale (GDS; (Yesavage et al., 1983) and the Mini Mental State Exam (MMSE; Folstein, Folstein, & McHugh, 1975) were administered to exclude participants with depression and dementia. The Wechsler Abbreviated Scale of Intelligence (WASI; Wechsler, 1999) provided a measure of verbal performance intelligence. Participants also completed the Rey Osterreith Complex Figure (Rey, 1941) and the Benton Visual Retention Test (BVRT; Benton, 1992).

A summary of the PD demographics and neuropsychological screening data are shown in Table 4.1.

---

<sup>1</sup> The Hoehn and Yahr scale is a commonly used system used for describing the progression of motor symptoms in PD. The scale runs from Stage 1 (Unilateral involvement with no or minimal disability) to Stage 5 (Wheelchair bound or bedridden unless aided). It is largely used in conjunction with the Unified Parkinson's disease Rating Scale which assesses limitation of daily activities and non-motor symptoms based on 10 clinical findings. It is used to follow the longitudinal course of PD (See appendix B).

---

---

---

## **Experimental tasks**

### **Stimuli**

The stimuli consisted of 2D novel patterns adapted from Tarr and Pinker (1990) – see Figure 4.1. In the Perceptual Matching task, each stimulus subtended  $16.23^\circ$  of visual angle horizontally and  $8.12^\circ$  vertically from a viewing distance of 60 cm. The stimulus items in the Recognition Memory task subtended  $7.16^\circ$  vertically and horizontally from a viewing distance of 60cm. The stimuli each consisted of straight-line elements. An upright (zero degree) orientation was defined in which the principal axis (containing the short horizontal foot or circle) was aligned vertically with the monitor. No stimulus items were mirror images of each other. Different sets of stimuli were used in each task in order to eliminate item-specific practice/transfer of training effects (Heil, Rosler, Link, & Bajric, 1998; Tarr & Pinker, 1990).

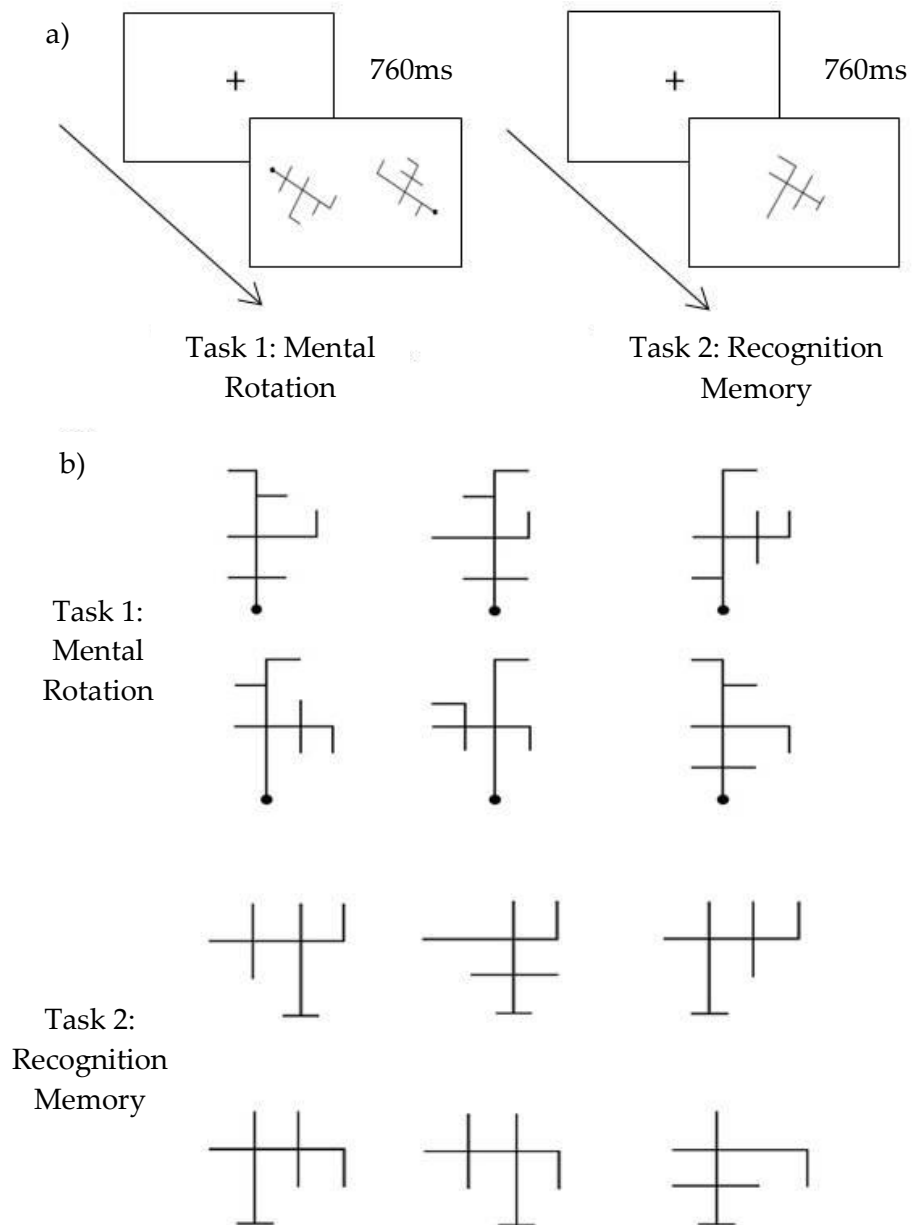

**Figure 4.1. (a) Schematic procedures for Task 1 (Mental rotation) and Task 2 (Recognition memory). (b) The novel object stimulus sets for both tasks. These objects are shown in at the 0° or upright orientation.**

### Apparatus

The stimuli were presented on a 17 inch monitor at a screen resolution of 1024 x 768 pixels.

Stimulus presentation was controlled by E-Prime software (Psychology Software Tools, Pittsburg, USA). Response latencies were measured in terms of voice-onset time (VOT) using a microphone attached to a PST serial response box model S200A. Response type was entered by the experimenter after each trial.

## **Design & Procedure**

The study used a 2 (Group: PD, Controls) x 2 (Task: Mental rotation, recognition memory) x 2 (Angular disparity: 60°, 120°) mixed design. Group was a between-subjects factor. Task and Angular disparity were within-subjects factors. The dependent variables were RTs (VOTs) and accuracy. PD patients were tested in the ON phase of their normal medication cycle. There were two testing sessions altogether (one for Task 1 and one for Task 2). The order of task administration was counterbalanced with an AB BA design. Prior to the experimental blocks of each task, a minimum of 8 practice trials were administered. The practice trials were presented on a loop until an accuracy rate of 80% was achieved before continuing onto the experimental block. The purpose of these practice trials was two-fold: to ensure that the vocal responses were being adequately received by the microphone and to familiarise the participant with the task. Task order was counterbalanced in an AB BA design.

### ***Task 1 (Mental rotation)***

In this task participants were presented with two stimuli on each trial, and were asked to judge whether the stimuli were the same shape regardless of stimulus orientation. The stimulus set is shown in Figure 1(b). On each trial a black fixation point (visual angle  $x = 0.48^\circ$ ,  $y = 0.40^\circ$ ) was shown on a white background for 750ms. This was followed by the stimulus pair which remained on the screen until a response had been made. The stimulus pair was shown side-by-side with the total display subtending  $30.75^\circ$  horizontally. On two thirds of the trials, the stimulus pairs were the same shape ( $N=96$ ), and on one third of the trials they were different ( $N=48$ ). Stimuli could be shown at the same orientation, or at  $\pm 60^\circ$  or  $\pm 120^\circ$  angular disparities in the image plane. Each angular disparity was probed 36 times. The trials were presented in two blocks of 72 trials each with a break in the middle. Each trial was initiated by the participant to allow for breaks whenever necessary. On each trial participants indicated whether or not the stimulus pairs were the same shape (regardless of orientation) using a vocal response which was used to determine VOT.

Participants responded by saying aloud the voiced phoneme /g/ if the two stimuli were the same shape and /k/ if the stimulus items were different. The experimenter indicated the response type (same/different shape) at the end of each trial on the serial response button box. Trial order was random. Tasks 1 and 2 were completed in separate sessions.

### *Task 2 (Recognition Memory)*

This task used a recognition memory paradigm. The task consisted of a learning phase and a test phase which were completed in the same session. A different set of novel objects were used in this study to reduce stimulus specific practice effects - see Figure 4.1(b).

#### *Learning Phase*

Participants were initially presented with a single randomly selected target stimulus which was traced and copied once at the upright (zero degree) orientation. This was followed by a computerised memorisation phase. On each trial a single stimulus (either the target or one of the five distracters) was presented in the centre of the monitor at the upright orientation. The task was to indicate whether the stimulus was the target or a non-target by saying aloud the voiced phonemes "g" for target and "k" for non-targets into the microphone. Response type was entered by the experimenter after each trial. There were 18 memorisation trials. If the participant failed to correctly identify the target to the criterion level of 80%, they continued until 80% of the responses made were correctly.

#### *Test Phase*

On each trial a black fixation point (visual angle  $x = 0.48^\circ$ ,  $y = 0.40^\circ$ ) was shown on a white background for 750ms. Following this one of the stimuli was shown which remained on the screen until a response was made. Participants responded using vocal responses for match (target) and mismatch (non-target) trials. The experimenter entered the response type (target or non-target) using the serial response box after each trial so that accuracy could be calculated. In total there were 180 trials (Targets  $N=120$ , Non-targets  $N=60$ ). For the critical trials, to allow comparison of

slopes to Task 1, stimuli were presented at three orientations:  $0^\circ$ ,  $\pm 60^\circ$ ,  $\pm 120^\circ$  in the image plane. In addition, to reduce orientation-specific practice effects, two additional orientations at  $\pm 90^\circ$  and  $180^\circ$  were included as filler trials. Each orientation was probed 36 trials in total across targets and non-targets (collapsed across symmetrical orientations). Trial order was randomised. At the end of the task, participants were asked to recall and draw the target stimulus object from memory at the upright orientation to ensure that the image had been retained in memory correctly.



## Results

### Experimental Tasks

For each task, response latency (VOT) and accuracy were recorded. VOTs for incorrect trials as well as those for correct trials which were greater than 2 SDs above the mean for the condition were eliminated (Task 1: Mental rotation = 6.7% of trials; Task 2: Recognition memory = 4.79% of trials). Table 2 shows the mean VOTs for correct response trials and accuracy as a function of condition across tasks.

**Table 4.2.**  
Mean Voice-onset times (VOTs) per condition and accuracy (% correct). Brackets show standard error of the mean.

		Mean VOTs (ms)			Mean Accuracy (% correct)		
		(SE)			(SE)		
		0°	60°	120°	0°	60°	120°
Task 1 Mental rotation	Controls	2049.36 (120.96)	2978.93 (317.58)	3027.69 (211.29)	100 (0.00)	85.27 (0.71)	93.30 (0.35)
	PD	3052.38 (331.50)	3846.29 (457.79)	4431.59 (556.73)	100 (0.00)	81.97 (0.62)	83.65 (1.12)
Task 2 Recognition Memory	Controls	624.78 (27.56)	665.89 (32.91)	705.46 (25.27)	99.48 (0.17)	98.44 (0.19)	98.44 (0.24)
	PD	1031.37 (94.75)	1097.02 (120.68)	1284.13 (179.24)	93.4 (1.18)	91.32 (0.92)	90.97 (1.12)

### Analyses of VOTs

Analyses were conducted on mean VOTs across tasks over angular disparities of 60 and 120 degrees. For Task 2 (Recognition memory) mean VOTs were calculated for correct responses to target trials only. The zero degree disparity was excluded from the main analyses to allow valid comparison of transformation rates over equivalent angular disparities across tasks; that is, under conditions where spatial normalisation would be required and stimulus familiarity is controlled. At zero or upright orientations stimulus matching could be accomplished without spatial

transformation via feature matching. Additionally, the zero or upright orientations are not equivalent in terms of stimulus familiarity: in Task 2 participants received prior exposure to the upright orientations during the learning phase of the study. Identically oriented stimuli would not be expected to involve spatial transformation and, for Task 2 (Recognition memory), performance for zero degree targets would benefit from prior exposure during the learning phase. For completeness, analyses of log transformed VOTs including the zero degree orientation are reported in Footnote 1. The log-transformation reduced the skew in the data and demonstrates that excluding the zero degree orientation from the analysis does not mask an underlying effect.

An initial 2 (Task: Mental rotation, Recognition memory)  $\times$  2 (Group: PD, Control)  $\times$  2 (Angular disparity: 60°, 120°) mixed ANOVA on mean VOTs showed significant main effects of Task  $F(1, 50) = 75.56, p < .001, \eta^2 = .60$ , Group  $F(1, 50) = 7.33, p = .009, \eta^2 = .13$ ; and Angular Disparity  $F(1, 50) = 20.12, p < .001, \eta^2 = .29$ . There were also significant two-way interactions between Angular disparity\*Group,  $F(1, 50) = 12.71, p = .001, \eta^2 = .20$ ; and Angular disparity\*Task,  $F(1, 50) = 4.51, p = .039, \eta^2 = .08$ ; and a three-way interaction of Angular disparity\*Group\*Task:  $F(1, 50) = 4.11, p = .048, \eta^2 = .08$ . These interactions were explored further by conducting separate ANOVAs on the mean VOT data for each task.

#### *Task 1 (Mental Rotation)*

A 2 (Group: PD, Control)  $\times$  2 (Angular disparity: 60°, 120°) mixed ANOVA on mean VOTs showed a significant main effect of Angular disparity,  $F(1, 25) = 12.55, p = .002, \eta^2 = .33$ ; and a significant Group\*Angular disparity interaction:  $F(1, 25) = 8.99, p = .006, \eta^2 = .264$ . Analyses of simple effects showed a significant effect of Angular disparity for the PD group,  $t(12) = 3.48, p = .005, d = 0.2$ ; but not for controls,  $t(13) = .66, p = .52, ns, d = 0.04$ .

*Task 2 (Recognition Memory)*

A 2 (Group: PD, Control) x 2 (Stimulus orientation: 60°, 120°) mixed ANOVA on mean VOTs showed a significant main effect of Group:  $F(1, 25) = 11.94, p = .002, \eta^2 = .32$  and Angular disparity:  $F(1, 25) = 10.74, p = .003, \eta^2 = .30$ . There was also a significant interaction of Group\*Angular Disparity:  $F(1, 25) = 4.55, p = .043, \eta^2 = .15$ . Analyses of simple effects showed significant effects of Angular disparity for both the PD group,  $t(12) = 2.64, p = .022, d = 0.3$ ; and for the controls,  $t(13) = 3.45, p = .004, d = 0.4$ .

*Analyses of Regression Slopes*

A key issue concerned the spatial normalisation rates of the PDs and controls across tasks. The normalisation rates were derived by computing the regression slope (ms/deg) on mean VOTs as a function of angular disparity. This provides a standardised measure of spatial transformation rate that is normalised for differences in the global mean VOTs across tasks. The mean regression slopes for the PD sample and controls are shown in Figure 2.

---

<sup>2</sup> Separate analyses using 2 (Group) x 3 (Angular disparity) mixed ANOVAs were conducted on log transformed VOT data across all three orientations. For Task 1 (Perceptual matching) there was a significant main effect of Group  $F(1, 25) = 6.61, p = .016, \eta^2 = .21$ ; and of Angular disparity  $F(2, 50) = 96.94, p > .001, \eta^2 = .80$ . There was also a significant interaction,  $F(2, 50) = 3.27, p = .046, \eta^2 = .12$ . For Task 2 (Recognition memory) there were also significant main effects of Group:  $F(1, 25) = 18.53, p > .001, \eta^2 = .43$ , and Angular disparity,  $F(2, 50) = 20.18, p = .000, \eta^2 = .45$ , but no significant Group x Angular disparity interaction,  $F(2, 50) = .83, p = .44, \eta^2 = .03$ . These analyses show the same basic pattern of results as those based on the comparison of slopes excluding the zero degree (upright) orientation consistent with a modulation of spatial transformation performance in PD by task.

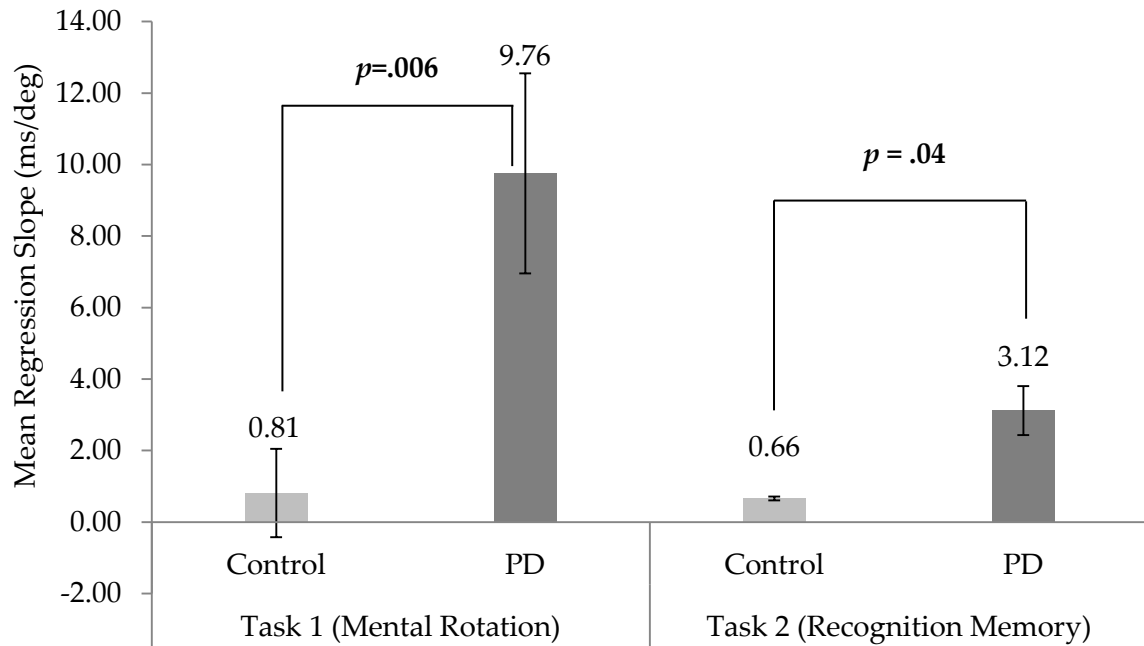

**Figure 4.2.** Mean regression slopes (ms/deg) for the PD and controls groups on each task.

A 2 (Task: Mental rotation, Recognition memory)  $\times$  2 (Group: PD, Control) mixed ANOVA showed significant main effects of Task,  $F(1, 50) = 4.51, p = .039, \eta^2 = .08$  and of Group,  $F(1, 50) = 12.71, p = .001, \eta^2 = .20$ . There was also a significant Group\*Task interaction,  $F(1, 50) = 4.11, p = .05, \eta^2 = .08$ . Analyses of simple effects showed a significant difference in mean slopes between PDs ( $M = 9.76, SD = 10.09$ ) and Controls ( $M = 0.81, SD = 4.61$ ) for Task 1 (Mental rotation),  $t(25) = 2.99, p = .006$ , and for Task 2 (Recognition memory): PD ( $M = 3.12, SD = 4.26$ ), Controls ( $M = .66, SD = .72$ ),  $t(25) = -2.13, p = .043$ . These analyses suggest that the PDs were impaired, relative to controls, in spatial transformation on both tasks, but that they were more impaired in the mental rotation than recognition task.

### *Analyses of Accuracy*

Mean accuracy across groups, tasks and angular disparity is shown in Table 2. A 2 (Task: Mental rotation, Recognition memory)  $\times$  2 (Group: PD, Control)  $\times$  2 (Angular disparity: 60°, 120°) mixed ANOVA on accuracy rates showed significant main effects of Task  $F(1, 50) = 15.81, p < .001, \eta^2 = .24$ , and Group  $F(1, 50) = 8.45, p = .005, \eta^2 = .14$ . There was no significant effect of Angular disparity;  $F$

(1, 50) = 2.90,  $p = .10$ ,  $\eta p^2 = .06$  and no significant interactions. Separate planned 2 (Group)  $\times$  2 (Angular disparity) ANOVAs were conducted on the accuracy rates for the individual tasks. For Task 1 there were significant main effects of both Group,  $F(1, 25) = 6.57$ ,  $p = .017$ ,  $\eta p^2 = .21$ , and Angular disparity:  $F(1, 25) = 5.73$ ,  $p = .025$ ,  $\eta p^2 = .19$ — reflecting higher accuracy for both groups at the upright (zero degree) orientation. There was no significant interaction. For Task 2 there were no significant main effects or interactions. All PD and control participants were able to successfully draw target items from memory in the upright orientation during the verification phase at the end of the experiment. This establishes that the target shapes had been successfully encoded and retained in memory throughout the study.

#### *Further analyses of spatial normalisation in PD*

In separate follow up analyses we used multiple regression analyses to determine whether the spatial normalisation rates shown by the patients correlated with the PD motor scores (UPDRS and H&Y), age or screening test results (MMSE, GDS, BVRT, Rey Figure or WASI). Independent samples  $t$  tests between the control group and the PD patient group on the screening data showed significant differences between groups on their level of depression measured by the Geriatric Depression Scale (GDS),  $t(26) = -2.14$ ,  $p = .042$ ,  $d = 0.8$ . There was a significant difference between the two groups on WASI Verbal IQ,  $t(26) = 2.95$ ,  $p = .007$ ,  $d > 1.0$ ; Performance IQ,  $t(26) = 2.02$ ,  $p = .054$ ,  $d = 0.8$  and Full IQ,  $t(26) = 2.74$ ,  $p = .011$ ,  $d > 1.0$ . There were no significant correlations between the regression slopes for spatial normalisation and the screening measures (Table 4.3).

---

---

---

---

---

---

## Discussion

The main results of the study can be summarised as follows: in both Task 1 (Mental rotation), and Task 2 (Recognition memory) the PD group showed steeper regression slopes (i.e., slower spatial normalisation rates) than controls. However, the degree of impairment was modulated by task: the PD group showed a greater slowing of transformation rates, relative to controls, in mental rotation than in recognition memory.

The findings of impaired spatial transformation are consistent with previous reports suggesting that PD can be associated with deficits to visuo-spatial processing (e.g., Lee et al., 1998; Levin et al., 1991; Montse, Pere, Carme, Francesc, & Eduardo, 2001; Pillon, Dubois, Ploska, & Agid, 1991). Additionally, the findings show that the deficit specifically affects the spatial normalisation component of task performance as reflected by elevated regression slopes or spatial normalisation rates, and cannot be accounted for solely in terms of deficits to other components of the task that might be expected to produce a fixed performance decrement (e.g., perceptual encoding of display elements, response selection and execution). This pattern of results could be accounted for in terms of cognitive slowing – that is, in relation to the time taken to compute a spatial vector between corresponding image locations.

Interestingly, a functional deficit affecting spatial normalisation in PD is also consistent with recent evidence about the role of premotor cortex, and in particular, the supplementary motor area (SMA), in spatial remapping. Evidence for this has come from a number of recent functional imaging studies in normal observers (e.g., Johnston et al., 2004; Lamm et al., 2001; Richter et al., 2000; Vingerhoets et al., 2001; Windischberger et al., 2003). More specifically, Leek and Johnston (2009) have argued that the ventral anterior (pre) SMA supports visuo-spatial processing by computing mappings of spatial vectors between

stimulus locations. According to this 'Vector transformation hypothesis' these computations are presumed to underlie a variety of tasks including the planning and online control of visually guided movement via the calculation of movement trajectories during the planning, and online control, of action, as well as abstract cognitive tasks like mental rotation, and object recognition, where image normalisation is required. Given its underlying pathology, and the consequent effects of striatal dopamine depletion on the SMA, this hypothesis specifically predicts impairments to visual transformation in PD.

PD performance in spatial transformation was found to be modulated by the task. This conclusion is supported by (1) the three-way interaction of Angular disparity x Group x Task and, (2) by the significant Group x Task interaction in the analysis of regression slopes. This suggests that spatial remapping in PD is sensitive to other task factors. Interestingly, both tasks required matching two stimuli across an orientation change: in mental rotation participants were required to determine the shape equivalence of two simultaneously presented images. In contrast, the recognition memory task required matching a perceptual representation of a stimulus to one held in long-term memory. One possibility is that the underlying pattern of performance across tasks could be explained in terms of working memory demands – which are known to affect PD (Gabrieli, Singh, Stebbins, & Goetz, 1996; Lee et al., 2010; Owen, Iddon, Hodges, Summers, & Robbins, 1997; Zahrt, Taylor, Mathew, & Arnsten, 2003) – assuming that working memory demands are higher when computing the mapping between two visible images, than between one perceptual and stored representation. Thus, computing spatial transformations can be assumed to require working memory capacity – which increases with the angular magnitude of the orientation difference between stimuli. Such an account places the underlying cause of the spatial transformation deficit with working memory rather than spatial remapping per se; that is, in the maintenance of outputs of sequential spatial mapping operations during task performance.



It is possible that these factors may contribute to the inconsistencies in visuospatial transformation research in PD.

An alternative explanation for steeper regression slopes for the between groups differences in image normalization rates is that the PD patient group was affected by cognitive slowing (Dominey et al., 1995; Lee et al. 1998; Press, Mechanic, Tarsy & Manoach, 2002; Sawamoto et al., 2002) as a result of dysfunctional fronto-striatal circuits (Owen, 2004). Thus, investigations of visuospatial processing should take care to judge the impairment based on measures which are specific to visuospatial ability such as accuracy on an appropriate task. The accuracy data for the present study show that the controls were significantly more accurate than PD patients on Task 1 but not Task 2 suggesting that PD is associated with a mental rotation deficit.

It must also be considered that both PD patients and controls were significantly more accurate at recognition memory than mental rotation suggesting that the recognition memory task may be easier. This can be explained in part by the cognitive demands of the task. While Task 1: Mental Rotation requires the mapping of coordinates from a stored representation to the stimulus, Task 2: Simultaneous Matching requires the simultaneous matching of coordinate locations from two objects, neither of which is already encoded in working memory. These cognitive processes are likely to result in slower voice onset latencies; consistent with spatial normalisation rates. Further, the strategy applied to complete the tasks may have differed. While an image plane rotation may have been successful during the mental rotation task, a feature matching strategy may have been sufficient to discriminate different shapes (Osborn & Agogino, 1992; Tarr & Pinker 1989).

An alternative explanation is that the dissociation between tasks found here reflects differences in the kinds of spatial transformation processes underlying mental rotation and object recognition. This is consistent with other evidence suggesting that visuo-spatial

processes underlying mental rotation are distinct from those supporting misoriented object recognition – where the latter may be dependent more on interpolation between views or on local feature matching (e.g., De Caro & Reeves, 2000; Gauthier et al., 2002; Hayward et al., 2006; Willems & Wagemans, 2001). It is relevant also that this dissociation has been reported elsewhere in the neuropsychological literature in relation to cases of orientation agnosia – in which patients show impairments in mental rotation without deficits in object recognition (Harris et al., 2002; Turnbull & McCarthy, 1996). The finding that the PD group were significantly more depressed than the control group is perhaps not surprising. However, there is evidence that depression may impact performance on spatial memory tasks (Gould et al., 2007). Similarly, consistent with some of the earliest evidence of spatial deficits in PD, patients were significantly poorer than controls on the WASI (Wechsler, 1999). While these findings have been previously attributed to impaired manual dexterity, it is unlikely that this accounts for the deficits observed in the present study as only the ‘block design’ component of the performance subset was sensitive to motor slowing. Further, impairments were also observed on the non-spatial verbal subset which has no time constraints or motor component. These aspects of the PD performance may, therefore, reflect a more general cognitive dysfunction, that is unrelated to visuo-spatial transformation.

In summary, the current study investigated the nature and generality of visuo-spatial processing impairments in PD. The results showed that PD can be associated with impairments that specifically affect spatial normalisation mechanisms that are sensitive to the magnitude of angular disparity. This was found in both tasks of mental rotation and recognition memory. Additionally, the magnitude of impairment in spatial transformation was modulated by task: being greater in the mental rotation task than in recognition memory. It is suggested that spatial transformation deficits in PD can be modulated by working memory and task demands.

## Chapter 5

### Study II: An investigation of vector transformation processes in visuospatial tasks other than mental rotation

#### Chapter Overview

The previous chapter presented evidence for a visuospatial transformation deficit in Parkinson's disease (PD) using variants of classic mental rotation tasks and considered the extent to which deficits in spatial transformation in PD can be accounted for by image normalisation processes. But do visual spatial processing deficits in PD extend to abstract vector transformation tasks beyond image normalisation?

Tasks used to investigate visuospatial function require additional cognitive demands such as spatial memory and the sequential or serial chaining of information (Kemps, Szmalec, Vandierendonck, & Crevits, 2005) and sequence processing (Pillon et al., 1998; Stoffers, Berendse, Deijen, & Wolters, 2003; Sawamoto et al., 2002). It is therefore necessary to separate these processes when investigating visuospatial ability.

To investigate these issues, PD patients and controls completed a spatial memory task, a visuospatial vector transformation task designed to assess the ability to compute non-motor spatial transformation, and a sequential number subtraction task to assess the ability to compute non-spatial sequential processing. The results showed that PD patients were impaired in spatial transformation relative to a control task of serial number subtraction that also required sequential processing. These findings further our understanding of cognitive impairment in PD, and also suggest that visuo-spatial processing deficits in PD extend beyond movement planning to support non-motor activity, including spatial navigation and mental rotation.

## Introduction

Visuospatial processing deficits in PD have been reported on a range of paradigms including mental rotation, navigation, line bisection and left right discrimination (see Cronin- Golomb, & Amick, 2001 for a review). While some researchers have reported impaired performance on visuospatial processing tasks, (Levin, et al., 1991; Montse, et al., 2001; Pillon et al., 1991; Lee, et al., 1998), others show no such deficit, (Amick, et al., 2006; Boller, et al., 1984; Duncombe, et al., 1994; Raskin et al., 1990).

One explanation for the inconsistencies in the literature on visuospatial processing in PD is that the studies reporting impairment, base their findings on complex tasks that require a number of cognitive processes beyond visuospatial ability such as visual working memory (Kemps, Szmalec, Vandierendonck, & Crevits, 2005) and sequence processing (Pillon et al., 1998; Stoffers, Berendse, Deijen, & Wolters, 2003; Sawamoto et al., 2002). Our previous investigations have shown PD deficits in mental rotation. PD patients have steeper spatial normalisation rates (that is they require longer processing times in terms of ms per degree) when matching two simultaneously presented stimuli than when matching stimuli to a stored mental representation, though impairment relative to controls were apparent on both tasks (Kerai, Bracewell, Hindle, & Leek, 2012). It can be argued that greater cognitive requirements are placed on simultaneous matching.

The question of dissociating visuospatial processing from other additional cognitive demands is of particular theoretical interest in the context of functional specialisation in the supplementary motor area (SMA) of the medial pre-motor cortex. At a computational level, these complex tasks are likely to engage a number of cognitive processes including spatial memory, spatial remapping of image features, serial chaining or operation sequencing, shape matching and response selection.

Sequence processing underlies many human activities such as language, skill acquisition, planning and problem solving. The information processing of sequences encompass anything which requires step by step processing with the concept of first, next, last etc. Sequence processing refers to the ability to encode, store, process and use information in an orderly fashion, linking events over time. It requires the online retention of information and sequencing behaviour in order to reach a specific goal.

PD patients have been reported to have difficulties with sequence learning which has been attributed in part to pre-SMA dysfunction (Kennerley, Sakai, & Rushworth, 2004; Nakamura, Sakai, & Hikosaka, 1998; Hikosaka et al., 1999). Task relative activation of neurons in the medial frontal cortex, particularly in the pre-SMA, has been observed in primates during sequence learning (Nakamura et al., 1998). Inactivation of the anterior striatum which receives input from the pre-SMA and dorsolateral prefrontal cortex has been shown to impair the learning of new sequences, (Miyachi, Hikosaka, Miyashita, Karadi, & Rand, 1997). To this end the altered activation of the pre-SMA in the pathology of PD suggests that sequence processing will be disrupted.

Pre-SMA has been associated with the organization or selection of sequential movements (Kennerley et al. 2004). In addition, connectivity between pre-SMA, prefrontal cortex and neural activity during abstract rule processing suggests a strong involvement of this area during the processing of abstract sequences (Bates, Goldman-Rakic, 1993; Luppino et al., 1993) demonstrating that the pre-SMA sub serves the processing of hierarchical structures in visuospatial sequences (Bahlmann, Schubotz, Mueller, Koester, & Friederici, 2009). The contribution of pre-SMA to sequential processing has been investigated in a task comparing activity during visuo-motor association and sequencing (Sakai et al., 1999). Pre-SMA activation was observed in all visuomotor paradigms but not in all sequencing

paradigms, suggesting that this area is related to visuo-motor association rather than motor or perceptual sequencing.

There is also a growing body of evidence that regions of the SMA also support non-motor cognitive functions (Johnston et al., 2004; Richter et al. 2000; Windischberger et al, 2003). One account – the vector transformation hypothesis (Leek & Johnston, 2009) proposes that these vector transformation computations are used in both motor and non-motor tasks that require spatial remapping and are presumed to underlie task such as planning and online control of visually guided movement by adding and subtracting numerical values that specify spatial locations. This is supported by imaging studies reporting that mental calculations, in particular, counting backwards, activate a network of regions including bilateral pre-SMA (Arthurs, Johansen-Berg, Matthews, & Boniface, 2004; Johnsen-Berg et al., 2004; Hanakawa et al., 2002; Johansen-Berg & Matthews, 2002).

Less clear is the role of pre-SMA in more abstract tasks of visuospatial transformation. Some supporting evidence comes from abstract grid navigation where participants were required to serially update mental representations in response to a series of visually presented cues (Sawamoto, et al., 2002). A subsequent imaging study measuring rCBF during three cognitive tasks: numerical addition, verbal, and spatial grid navigation, reported that the three tasks evoked significantly more pre-SMA activation than control tasks of visual fixation and finger tapping (Hanakawa et al. 2002). These findings support the involvement of pre-SMA in mathematical spatial computations. However, at present it is remains unclear how other aspects of task performance could contribute to poor performance in PD including sequence processing and visuospatial short term memory.

Study II assesses spatial memory in PD patients compared with controls. Performance on a sequential visuospatial transformation task and a sequential number subtraction task - both of which require sequential processing demands, are also compared.

These comparisons allow us to establish whether visuospatial processing deficits in PD extend to abstract vector transformation tasks beyond mental rotation to abstract grid navigation and whether these deficits could be accounted for by associated impairments in spatial memory or sequence processing.

If PD is associated with visuospatial transformation deficits, then performance of the PD patient group would be poorer on the visuospatial transformation task but spared on the non visuospatial tasks. Additionally, if sequential information processing is affected by PD, deficits will be demonstrated on both tasks requiring these cognitive operations.

## **Methods**

### **Participants**

Thirteen patients with a diagnosis of idiopathic Parkinson's disease (mean age 64yrs, range 47-72yrs,  $SD=7.72$ ) were recruited from a local Parkinson's disease clinic. They had a Hoehn and Yahr score of 1-3 and a minimum score of 26 on the MMSE. Twenty aged matched control participants (mean age 64.9yrs, range 51-73yrs,  $SD=7.15$ ) with no neurological history were also involved in the study. Both the patient and control groups were made up of different participants from those in Chapter 4. Research was approved by the NHS and University ethics committees in accordance with the Declaration of Helsinki. Written informed consent was obtained before testing.

### **Neuropsychological Background and Screening Tests.**

The Mini Mental State Exam (MMSE; Folstein et al., 1975) was used to assess the degree of cognitive dysfunction in PD patients. The Hoehn and Yahr (1967) scale provided a description of the progression of Parkinsonian symptoms. Visual memory was measured by the Benton Visual Retention Test (BVRT, Benton, 1992). The Wechsler Abbreviated Scale of Intelligence

(WAIS; 1999) was administered to measure verbal and performance intelligence. A detailed description of the PD sample, clinical sub-type is shown in Table 5.1.





## Apparatus

The experiments were programmed using E-Prime (Psychology Software Tools, Pittsburgh, USA) and presented on a 17inch VGA monitor running at a screen resolution of 1024 x 768 pixels. Behavioural responses were recorded using a microphone and a serial response box (Psychology Software Tools). Stimuli were viewed from 50 cm. Viewing distance was controlled using a chinrest.

## Experimental tasks

There were three experimental tasks assessing spatial memory (Task 1) sequential spatial vector transformation (Task 2) and sequential number subtraction (Task 3). The ISI for the spatial memory task (Task2) was set at 5000ms to exceed the maximum retention time required between stimulus presentations to complete the two sequencing tasks. Tasks 2 and 3 used similar trial sequences and trial durations (see Figure 5.1) allowing us to compare performance across tasks as a function of the underlying cognitive operation involved (spatial memory, vector transformation and sequential processing).

### Task 1: Spatial Memory

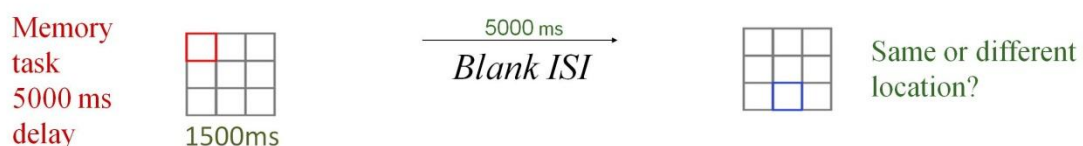

### Task 2: Sequential Vector Transformation

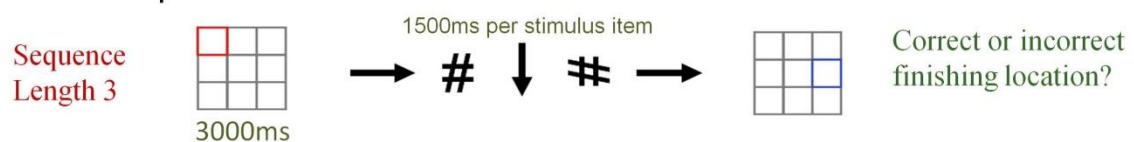

### Task 3: Sequential Number Subtraction

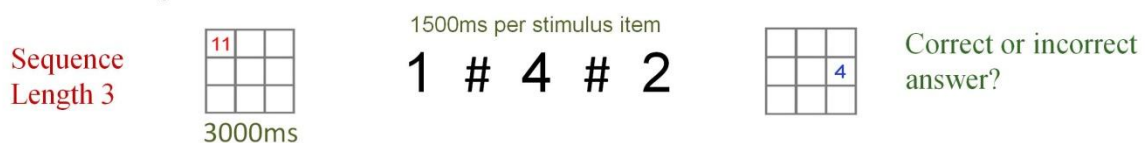

Figure 5.1. Trial Sequences for Tasks 1, 2, and 3.

Dependent measures were response accuracy and voice onset times (VOTs).

Response times (VOTs) were obtained using a voice-key in order to avoid any requirement to make a manual response. Responses (correct/incorrect) was recorded by the experimenter following each trial.

### ***Task 1: Spatial Memory***

#### *Stimuli*

The stimulus items were 9 starting 3 x 3 grids (450 x 450 pixels) each with one square outlined in red. There were 9 response grids which were the same as the starting grids but had a single square outlined in blue. Each stimulus grid subtended a visual angle of 11.36° horizontally and vertically from a viewing distance of 60cm.

#### *Design and Procedure*

Participants saw a starting grid which was presented for 1500ms in the centre of the monitor. They were asked to remember the location of the highlighted square. This was followed by a blank screen memory delay lasting either 2000ms or 5000ms, followed by a response grid. When the response grid was shown, participants responded vocally with the phoneme /g/ if the location on the grid highlighted was the 'same' as the starting grid and /b/ if the location on the response grid was 'different'. There were 54 trials divided into two session blocks, 27 trials for each ISI interval condition. Half the trials required a 'same' response and half the trials required a 'different' response. Each square on the grid was probed as a starting location 6 times. Participants initiated the start of each trial as was the case for all the experiments presented here.

### ***Task 2: Sequential Spatial Vector Transformation***

#### *Stimuli*

The starting and response grids were the same as for Task 1. There were four arrows pointing either left, right, up and down and four place holding hash marks (#). The up and

down arrows were presented at visual angles  $2.86^\circ$  horizontally and  $7.63^\circ$  vertically. The left and right arrows were presented at  $7.63^\circ$  horizontally and  $2.86^\circ$  vertically. The place holding hashmarks measured  $235 \times 175$  pixels and subtended a visual angle of  $4.39^\circ$  horizontally and  $5.92^\circ$  vertically. The hash mark was rotated from the upright by  $90^\circ$  to produce a second stimulus and then each was mirror reversed to create 4 stimulus items altogether.

#### *Design and Procedure*

There were three trial length conditions; 2, 3 and 4 arrows and 12 trials per condition. The starting locations were always one of the four corners of the grid (top left, top right, bottom left or bottom right) and each starting location was probed 12 times. There were 48 trials altogether presented in 2 blocks of 24. Half the trials required a 'correct' response ( $N=24$ ) and half required an 'incorrect' response ( $N=24$ ). The order of trials was randomised within blocks and participants initiated the beginning of each trial.

On each trial, participants first saw a  $3 \times 3$  square grid for 3000ms, with a single red highlighted square which denoted the start location. The grid was then removed from the screen and followed by a variable sequence of either two, three or four arrows and placeholders (hash marks, #) presented centrally. Participants were instructed to ignore the placeholders. Each arrow or place holding hash mark was presented for 1500ms. At the end of the sequence a response grid was presented with a single highlighted blue square. The response grid remained on the screen until a vocal response was recorded. Participants were instructed to decide, as quickly and accurately as possible, whether the location of the blue highlighted square in the response grid matched the location that would arise following the sequence of movements from the start location indicated by the arrows. They responded with the phoneme /g/ if the finishing location was correct and /b/ if the finishing location was incorrect.

### ***Task 3: Sequential Number Subtraction***

#### *Stimuli*

Nine starting grids with the same parameters as those of Task 1 had one square with a red number ranging from 9-18. The response grids had a blue number in one of the squares ranging from 1-16. There were also 9 number stimuli 1-9 in black font size 48 at visual angle 3.10° horizontally and 5.05° vertically. Four grey hash marks (#) were placeholders to keep trial lengths constant and had the same parameters as those in Task 2.

#### *Design and Procedure*

The experiment had three conditions (sequence lengths 2, 3 and 4). Participants saw the starting grid with a number in red for 3000ms. They were then instructed to mentally, serially subtract the numbers which followed from the starting number and ignore the hash marks. The numbers and hash marks were presented for 1500ms per stimulus. When the response grid was presented, participants responded whether or not the number in the response grid was correct or incorrect if the numbers had been serially subtracted from the starting number. The responses were recorded in the same manner as for Task 2. There were 48 trials altogether, (16 for each sequence length) and they were presented in two session blocks.

#### *Statistical Analysis*

For all of the tasks, an a priori alpha level of .05 was adopted. Exact  $p$  values are reported, except where  $p < .001$ . Effect size is reported using partial eta squared ( $\eta p^2$ ). Response latency (voice onset time; VOT) and accuracy were measured.

## Results

Voice onset times (VOT) for incorrect trials and VOTs more than 2 standard deviations above the mean for each condition were excluded from the analysis (Task 1: Spatial Memory= 7.91% of trials; Task 2: Sequential Vector Transformation = 7.10% of trials; Task 3: Sequential Number Subtraction = 6.16% of trials). Arcsine square-root transformations were applied to the percentage accuracy data to normalise the distribution before analysis. The VOT data were transformed using Log10 transformation prior to analysis.

### Task 1: Spatial Memory

Overall response accuracy was high for both the PD group ( $M=92.48$ ;  $SD=2.38$ ) and control group ( $M=91.74$ ,  $SD=4.68$ ). A 2(Group)  $\times$  2(ISI delay) repeated measures ANOVA on percentage accuracy showed no significant main effects or interactions. Similarly, a 2(Group)  $\times$  2(ISI) repeated measures ANOVA of response times found no significant main effects or interactions.

a. Mean accuracy.

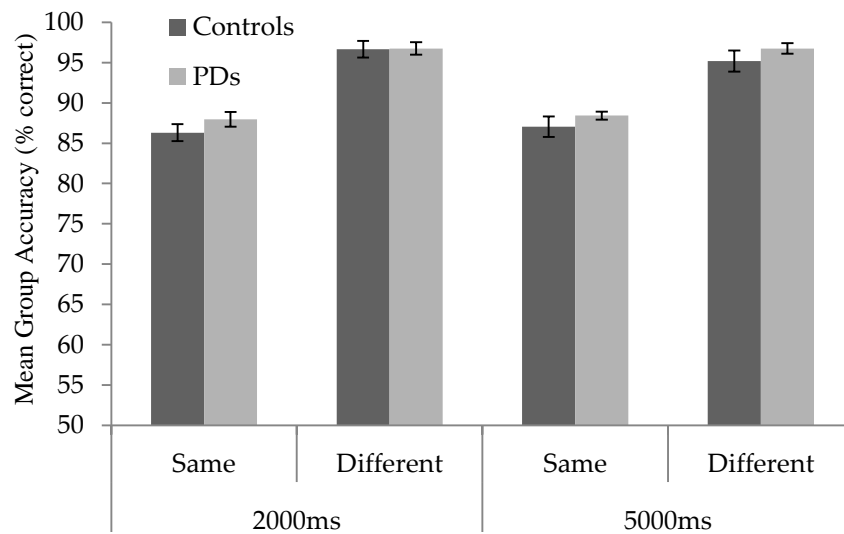

b. Mean VOTs

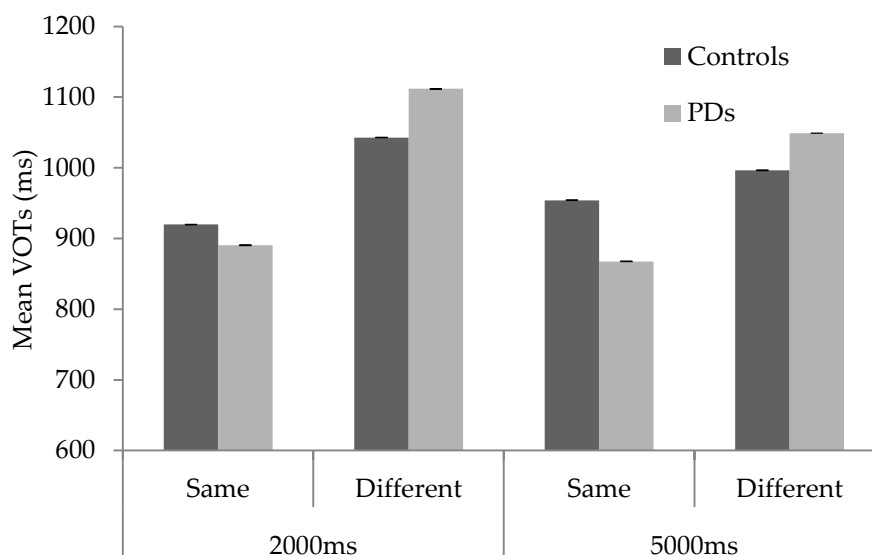

**Figure 5.2. Mean percentage accuracy and response times (ms) across ISI conditions on the spatial memory task for PD patients and controls on the spatial short term memory task. Error bars represent standard error of the mean.**

### **Task 2: Sequential Vector Transformation Vs Task 3: Sequential Number Subtraction**

A 2(Group) x 2(Task) x 3(Sequence Length) repeated measures ANOVA on accuracy data revealed a significant effect of group  $F(1,62) = 13.04, p = .001, \eta p^2 = .17$ , a significant main effect of task,  $F(1,62) = 8.65, p = .005, \eta p^2 = .12$  and no significant effect of sequence length  $F(2,124) = .234, p = .79, \eta p^2 = .004$ .

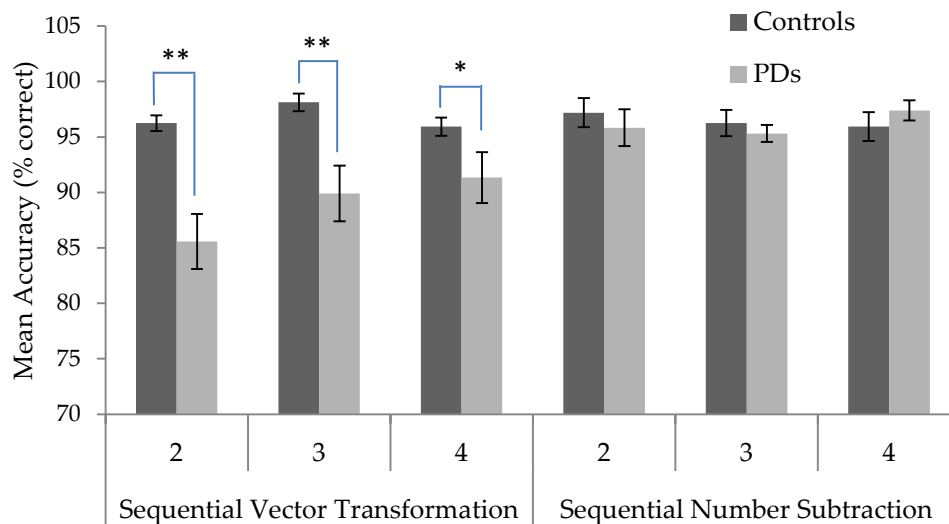

**Figure 5.3. Percentage accuracy across the sequential processing tasks as a function of group and sequence length. Error bars represent standard error of the mean.**

There was a significant Group \* Task interaction  $F(1,62) = 8.27, p = .006, \eta^2 = .12$ , and Sequence Length\*Task interaction,  $F(2,124) = 5.91, p = .004, \eta^2 = .09$ . There were no other significant effects. The two tasks were then explored separately.

### Task 2: Sequential Vector Transformation

A 2(Group) x 3(Sequence Length) repeated measures ANOVA of accuracy data showed a significant effect of group  $F(1,31) = 21.00, p < .001, \eta^2 = .40$ , and a significant effect of sequence length  $F(2,62) = 4.10, p = .021, \eta^2 = .12$ . The two way interaction was not significant  $F(2,62) = 1.99, p = .15, \eta^2 = .06$ .

Simple effects were investigated with a one-way ANOVA to determine how PD patients and controls differed on each sequence length. The control group were more accurate than PD patients on sequence length 2,  $F(1,32) = 18.12, p < .001, \eta^2 = .37$  (Controls:  $M = 96.25, SD = 3.14$ ; PD:  $M = 85.58, SD = 8.95$ ), sequence length 3,  $F(1,32) = 14.87, p = .001, \eta^2 = .32$  (Controls:  $M = 98.13, SD = 3.57$ ; PD:  $M = 89.90, SD = 9.03$ ) and sequence length 4  $F(1,32) = 4.37, p = .045, \eta^2 = .12$  (Controls:  $M = 95.94, SD = 3.67$ ; PD:  $M = 91.35, SD = 8.28$ ).



For the VOT data for correct response trials after removal of outliers (7.10% of trials), a 2 (Group) x 3 (Sequence length) mixed ANOVA showed significant main effects of group,  $F(1,31) = 7.33, p = .011, \eta p^2 = .19$ , and of sequence length,  $F(2,62) = 37.17, p > .001, \eta p^2 = .55$ . There was also a significant group\*sequence length interaction,  $F(2,62) = 9.32, p > .001, \eta p^2 = .23$ . The PD group was significantly slower at responding than the control group on sequence length 2  $F(1,31) = 14.47, p = .001, \eta p^2 = .32$ , but not for sequence length 3,  $F(1,31) = 2.88, p = .10, \eta p^2 = .09$  or Sequence length 4  $F(1,31) = 3.94, p = .056, \eta p^2 = .11$ .

### Task 3: Sequential Number Subtraction

A 2(Group) x 3(Sequence Length) repeated measures ANOVA found no significant main effect of group  $F(1,31) = .271, p = .606, \eta p^2 = .009$ , no effect of sequence length  $F(2,62) = 2.03, p = .14, \eta p^2 = .06$ . There was no significant group\*sequence length interaction  $F(2,62) = 1.01, p = .37, \eta p^2 = .03$ .

A similar pattern was found with the VOT for correct responses following removal of outliers (6.16% of trials). A 2 (Group) x 3 (Sequence length) mixed ANOVA showed a significant main effect of sequence length,  $F(2, 62) = 5.65, p = .006, \eta p^2 = .15$  but no other significant effects.

### Further Analysis of Screening Measures

Independent samples t-tests between the control group and the PD patient group on the screening data showed significant differences on MMSE  $t(31)=2.75, p = .010, d = .99$  and the verbal subset of WASI,  $t(31) = 2.12, p = .043, d = .76$ .

Separate correlation analyses were conducted to establish whether the visuospatial transformation performance of the PD group correlated with H&Y, age and performance on neuropsychological screeners. Bivariate correlations can be seen in Table 5.2.

The significant correlation between spatial short term memory and vector transformation was further investigated with separate correlations between accuracy spatial

short term memory and each sequence length of the vector transformation task. A significant relationship was found between spatial short term memory and vector transformation for sequence length 4, the longest sequence length condition tested,  $r = .660$ ,  $n = 13$ ,  $p = .014$ , suggesting that the more difficult or complex a spatial transformation tasks becomes, the greater the impact of visuospatial short term memory.

---

---

---

---

---

---

## Discussion

The aim of Study II was to examine whether visuospatial deficits in PD patients generalise to tasks other than mental rotation and examine how whether any such generalised visuospatial deficits can be accounted for by spatial memory and sequence processing impairments.

The main findings of the study can be summarised as follows: PD patients showed normal spatial memory but were less accurate at computing visuospatial transformation in grid navigation. The two groups did not significantly differ on accuracy or response latency on the sequential number subtraction task which also required the serial chaining of mental operations. The findings provide new evidence that PD can specifically affect cognitive processes related to the computation of the transformation or the remapping of spatial vectors.

The findings from the spatial memory task challenge previous research investigating PD and spatial encoding at the most basic level (Pillon, Ertle, Deweer, Sarazin, Agid & Dubois, 1996). Pilon et al. (1997) attributed the impairments observed in newly diagnosed, un-medicated PD patients to frontal lobe dysfunction due to lesions of the nigrostriatal dopaminergic system. The patients in the current sample were undergoing dopaminergic treatment which is likely to have restored the level of function of these nigrostriatal dopaminergic systems. Additionally, the delay interval did not differentially affect ability to encode spatial locations and maintain the specific location of the cue in working memory. Thus, the impairment of visuospatial processing cannot solely be accounted for by a spatial memory deficit.

The contribution of sequential processing to the visuospatial transformation deficit observed in Task 2 was investigated by comparing performance with Task 3 - Sequential

number subtraction. Normal performance on the non visuospatial task suggests that the processing of sequential chains of operations alone cannot adequately account for the observed impairments on the sequential vector transformation task. Existing literature associates pre-SMA dysfunction in PD with a deficit in chaining sequences of movements, planning sequences in advance and performing behavioural acts in multiple steps (Brown, Soliven, & Jahanshahi, 1998; Cronin-Golomb, Corkin, & Growdon, 1994; Wallesch, Karnath, & Zimmermann, 1992). This may explain the PD impairment to the vector transformation task that requires spatial remapping and spared performance on sequential number subtraction.

Visuospatial impairments in PD have been attributed to a central processing deficit than from a specific visuospatial processing problem (Dubois & Pillon, 1996). However, the conditions under which the present visuospatial transformation deficit was observed are matched to the number subtraction task challenging this assumption; the impairments appear to be specific to visuospatial transformation.

One hypothesis proposes that spatial impairments occur in tasks which require an intact ability to spontaneously generate strategies for online planning (Buytenhuijs et al., 1994; Jahanshahi et al., 1995). The sequential vector transformation task requires these planning processes to be generated and implemented rapidly. Taken together with evidence of cognitive slowing in PD (Sawamoto et al., 2002), such timing constraints may account for the impairments observed on sequential visual vector transformation.

In addition to cognitive slowing, PD has been associated with impairments to executive functions such as working memory and cognitive flexibility. As the current task requires the location on a grid to be stored and manipulated to reach a goal, impairments observed in this task may have been due to the spatial working memory impairment

thought to be the result of a disruption of visual spatial processing circuits involving antedorsal regions of the caudate nucleus (Possin et al., 2008; Postle & D'Esposito, 1999).

Impairments of spatial transformation in PD patients may also be explained by high cognitive demands of the spatial task when compared with serial subtraction. During serial subtraction, the semantic information of the number is enough to successfully complete the task. The demands of cognitive flexibility to constantly update information and process irrelevant information to reach a goal are higher on the spatial transformation task than serial subtraction.

It is surprising that PD patients were less accurate on the shorter sequence lengths than on the longer sequence lengths. Thus, when there was more relevant information to be processed and less irrelevant information, PD patients were more accurate. A possible explanation for this is that PD patients reported that the place holding hashmarks were distracting with their similarities to the grid stimuli. This may have made it difficult for PD patients to maintain attention (Luque-Moreno, Lopez-Garcia, & Diaz-Argandona, 2012). Further, it is unclear whether the spatial short term memory task was adequate enough to assess memory for spatial locations. There was no dual task interference to prevent participants assigning names to the locations on the grid (e.g. bottom left). Thus, the PD patient's ability to maintain a spatial location between arrow presentations and the response grid could have led to lower accuracy on the shorter sequence length conditions.

Previous imaging studies have reported that serial subtraction activates brain regions including pre-SMA and is commonly used as a pre-SMA localisation task (Johansen-Berg & Matthews, 2002; Arthurs, et al., 2004). By hypothesis, pre-SMA function should be impaired in PD patients; hence, an impairment of sequential number subtraction is expected. It is of interest therefore that PD patients perform normally on sequential number subtraction. Sequential subtraction may be spared because mathematical computations are regularly

practiced and processed quickly during mental arithmetic. Support for this assumption also comes from SMA activation during well practiced/learnt behaviours (Grafton et al., 1992) which may account for pre-SMA activity during mathematic computation. In contrast, unpractised abstract mental transformations of space are more likely to have been subject to slowness of processing making it difficult to maintain temporal control of the task (Sawamoto et al., 2002).

It is relevant also to note that while there was a significant correlation between performance in the grid navigation and spatial memory screening task, none of the PD patients were impaired, relative to controls, in spatial memory. The correlation presumably arises because a failure to encode the grid location of an arrow cue will necessarily disrupt performance regardless of whether the patient is impaired in spatial vector transformation (that is, in computing the new location following execution of the directional shift indicated by the arrow cue).

The direction of the arrows may have affected visual attention in cases where participants were unable to inhibit shifting fixation to the depicted direction; impairments associated with dysfunctional dopaminergic systems (Wright, Burns, Geffen, & Geffen, 1990; Sampaio et al., 2010). In particular, PD impairments have been observed in the directing of attention (Morris, Iansak, Matyas, & Summers, 1996; Bond & Morris, 2000), sustained attention (Luque-Moreno, Lopez-Garcia, & Diaz-Argandona, 2012), and the rapid relocation of the focus of visual attention (Baldo, Mota, & Silva, 2006). Though the directing of attention and sustaining of attention are not likely to underlie impairments in visual vector transformation, the rapid relocation of visual attention may have influenced patient gaze between stimuli. These attentional confounds can be addressed with eye tracking research investigating the sensitivity in PD vision to directional cues. One function of pre-SMA is the

computation of abstract transformations which affect the remapping between spatial vectors within, and between, spatial coordinate systems. Such computations may underlie the planning and online control of visually guided movement, as well as the spatial transformations required by any cognitive task that involves spatial remapping – including mental rotation and abstract grid navigation. The present findings extend previous work by showing that deficits in visuo-spatial processing in PD can extend beyond mental rotation to other tasks requiring spatial transformation, and that impaired performance cannot be accounted for by deficits in spatial memory or sequencing per se. This is not to say that pre-SMA is not involved in either spatial memory or sequencing. Indeed, there is a growing body of evidence that the SMA is not a functionally homogenous area but rather sub-serves a range of cognitive operations (e.g., Chung et al., 2005; Nachev et al., 2008). Furthermore, PD has also been independently associated with difficulties in the sequencing of complex movements and sequence learning (Brown, Soliven, & Jahanshahi, 1998; Cronin-Golomb et al., 1994; Nakamura et al., 1998; Wallesch et al., 1992).

The present findings extend the previously reported visuospatial processing deficits in PD (as demonstrated by larger spatial normalisation rates) go beyond mental rotation to other visuospatial transformation tasks and that these deficits are not influenced by an inability to encode and store spatial locations.

In summary, PD patients and aged-matched controls completed a series of tasks designed to assess abstract sequential visuo-spatial transformation, sequential serial number subtraction and spatial memory. The results showed that PD patients were impaired in abstract spatial transformation but not in sequential number subtraction or spatial memory. These findings suggest that visuo-spatial processing impairments in PD cannot be wholly accounted for in terms of a general deficit in the serial chaining or sequencing of cognitive operations or spatial memory. Rather, PD can specifically affect cognitive mechanisms that



support spatial vector transformation. It is suggested that this impairment results from the effects of nigro-striatal dopamine depletion in PD on the functioning of spatial vector transformation systems.

## Chapter 6

### Study III: An investigation of the domain specificity of pre-SMA in vector transformation processes

#### Chapter Overview

This chapter explored the domain specificity of spatial transformation deficits in Parkinson's disease (PD). Study II, described in Chapter 5, found that PD patients were impaired relative to controls at abstract grid navigation. Though these findings suggest PD impairments in visual vector transformation processes, it remains to be established whether vector transformation processes are affected in the auditory domain.

Posterior parietal cortex is associated with visual and auditory spatial mapping and sends output to frontal motor areas including supplementary motor areas (SMA; Cohen, Russ, & Gifford, 2005; Weeks et al., 2000; Colby & Goldberg, 1999; Heinze et al., 1994). Thus the spatial mapping of visual and auditory information is of interest when investigating pre-SMA in the context of the vector transformation hypothesis.

Pre-SMA activity has been observed in visual and auditory conditional choice paradigms suggesting that pre-SMA is modality general and involved in sensory motor integration (Kurata et al., 2000). The shared activation of visual and auditory stimuli suggests that information from both modalities is likely to be processed in the same way in terms of identity and location.

Previous findings of vector transformation demonstrate PD deficits in spatial normalisation (Chapter 4) and visual abstract grid navigation (Chapter 5). It is not clear whether impairments in visual vector transformation extend to auditory vector transformation, more specifically, whether vector transformation processes are domain general.

PD patients performed visual and auditory versions of abstract grid navigation tasks. The group level of analysis found that the PD patients and controls differed significantly in visual vector transformation but not in auditory vector transformation. The individual patient level of analysis supported the association of task suggesting that vector transformation is specific to the visual modality. However, a double dissociation is suggested by one patient demonstrating impairment in the auditory task with spared visual vector transformation and another patient showing the opposite pattern. These findings raise the possibility that auditory and visual stimuli recruit vector transformation processes independently.

## **Introduction**

We use both auditory and visual spatial information to interpret the world around us. Both modalities enable us to determine the location, speed and direction of moving stimuli; stimulus mapping and tracking. Neuroimaging research has shown that posterior parietal cortex is associated with the spatial mapping of visual and auditory stimuli (Cohen, Russ, & Gifford, 2005; Weeks et al., 2000; Colby & Goldberg, 1999; Heinze et al., 1994). Posterior parietal cortex sends output to frontal motor cortex including dorsolateral prefrontal cortex, supplementary motor areas and frontal eye fields. The pre-SMA is of particular interest in the context of the vector transformation hypothesis.

The pre-SMA, as well as dorsal premotor areas are active when visual spatial and auditory-spatial cues are presented (Fink, Dolan, Halligan, Marshall & Frith, 1997; Grafton, Gagg, & Arbib, 1998; Hazeltine, Grafton, & Ivry, 1997; Iacoboni, Woods, & Mazziotta, 1998). In addition, visual and auditory versions of a conditional choice reaction time paradigm activated pre-SMA in equal magnitudes (Sakai, Stepniewska, Qi, & Kaas, 2000). Taken

together, these findings suggest that pre-SMA is not modality specific and plays a role in sensorimotor integration (Kurata et al., 2000).

Given the shared activation of pre-SMA during visual and auditory stimulus processing, it is likely that information from both modalities is subject to similar processes with regards to the identity and/or the location of objects. The visual identification and localisation of objects is functionally segregated to ventral and dorsal streams respectively. The occipitotemporal pathway specialises in object identity and occipitoparietal pathway preferentially processes spatial relations among objects (Haxby et al., 1991; Livingstone & Hubel, 1988; Mishkin & Ungerleider, 1982). Like the visual system, the auditory system must process the identity and location of stimuli (Romanski et al., 1999). Research has identified segregated pathways for identification and localisation of sounds (Alain & Bernstein, 2008; Altmann, Bledowski, Wibral, & Kaiser, 2007; Salmi, Rinne, Degerman, Salonen, & Alho, 2007) suggesting similarities in the way visual and auditory stimuli are processed.

Traditionally, pre-SMA has been associated with the online selection of appropriate responses (Deiber et al., 1996; Humberstone et al., 1997; Petit, Courtney, Ungerleider, & Haxby, 1998; Ikeda et al., 1999; Sakai et al., 1999), the selection and control of motor plans, (Matsuzaka & Tanji, 1996; Tanji, 1996; Shima et al., 1996) and when responding to unpredictable visual stimuli (Dassonville et al., 1998). More recently, pre-SMA has been associated with mental image transformations in tasks such as mental rotation (Johnston et al., 2004). An explanation for the role of pre-SMA in mental transformation is the suggestion that one function of pre-SMA is to spatially assign coordinates to images and use these coordinates to perform transformations of mental images (Johnston & Leek, 2009).

PD has consistently been associated with under-activity of the pre-SMA as a result of nigro striatal dopamine depletion (Fukuda et al., 2001; Sabatini et al., 2000; Thobois et al., 2000) which, by hypothesis, suggests that deficits should be observed in PD patients on tasks

which require the remapping of spatial coordinates. This has been demonstrated in previous studies described in this thesis, e.g. mental rotation and abstract grid navigation.

Our previous findings in Study II, support impaired visual abstract grid navigation in PD. PD patients demonstrated abnormal performance on spatial navigation guided by visual arrow cues. The cues were presented serially and participants navigated around a 3x3 grid from a highlighted starting location. A serial number subtraction task with the same parameters as the spatial navigation task showed normal performance when no spatial transformation was required. Thus the serial processing of information did not account for the observed deficit in spatial transformations. Though these findings suggest spatial transformation impairments in PD may be associated with pre-SMA, the modality generality of these processes remains unclear.

We are able to perceive distance and direction of a sound source which theoretically encompasses the principles of vector transformation for the spatial mapping of auditory space. While we have shown abnormalities in how PD patients perform visually cued vector transformation in Study II, it is unclear whether the vector remapping processes are involved in the computation of visuospatial transformations modulated outside the visual domain.

This study examines this issue using two tasks. The vector transformation navigation task requires the mental image of the starting column to be retained and transformations to be performed based on visual cues (arrows pointing up or down) and auditory cues (high pitched tone - move up one place, or low pitched tone – move down a place). Both tasks require the same processes to complete the trials in that the same transformations are performed in the visual and auditory tasks.

If vector transformation is sensitive to visuospatial transformation modulated by visual and auditory stimuli, PD patient impairments are expected on both vector

transformation tasks. Task dissociation will suggest that vector transformation processes are modality specific to the impaired modality.

## **Methods**

### **Participants**

Sixteen patients with a diagnosis of idiopathic Parkinson's disease (mean age 63.38yrs, range 51-78yrs, SD=7.82) were recruited from a local Parkinson's disease clinic. They had a Hoen and Yahr (1967) score of 1-3 and a minimum score of 26 on the MMSE (Folstein et al., 1975).

Seventeen aged matched control participants with no neurological history were also involved in the study. Both the patient and control groups were made up of different participants from those in Chapters 4 and 5. Research was approved by the NHS and University ethics committees in accordance with the Declaration of Helsinki. Written informed consent was obtained before testing.

### **Screeners**

The Mini Mental State Exam (MMSE) was used to assess the degree of cognitive dysfunction in PD patients. The Hoen & Yahr scale provided a description of the progression of Parkinsonian symptoms. The Benton Visual Retention Test (BVRT; Benton, 1955) measured visual perception and visual memory. The Wechsler Adult Scale of Intelligence (WASI; 1999) measure was also administered to all participants. A summary of the screening data can be seen in Table 6.1.

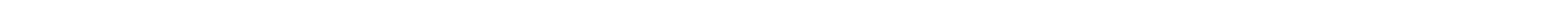

## **Experimental Tasks**

### *Apparatus*

The experiments were presented on a screen with a 1024 x 768 pixel resolution using E-prime (Psychology Software Tools, Pittsburg, USA). Response latencies were measured in terms of voice-onset time (VOT) using a microphone attached to a PST serial response box model S200A. Response type (correct/incorrect) was entered by the experimenter after each trial.

### *Design*

The study used a 2(Group: PD, Controls) x 2(Task: Auditory, Visual) x 3(Sequence Length: 2, 3 and 4) design. The between subject factor was group, the within subject factors were task and sequence length. The dependent variables were voice onset time (VOT) and accuracy. There were 48 trials altogether; 16 trials per sequence length condition. Half of the trials required a correct response and half the trials required an incorrect response. The trials were divided into two blocks of 24 with a break in between. Each trial was initiated by the participant to allow for breaks when necessary. The two experiments were administered on separate occasions to minimise the practice effects and the order of task completion was counterbalanced.

### **Task 1: Visual Transformation Task**

#### *Stimuli*

The stimulus items consisted of 9 grey starting 1 x 3 grids (150 x 450 pixels) with one square outlined in red. There were 9 response grids which were the same as the starting grids but had a single square outlined in blue. There were also two black arrows pointing up and down and four space filler grey hash marks at the upright and rotated 90° and a mirror image of both. The grid stimuli subtended 11.36° horizontally and 3.72° vertically, the arrow



stimuli  $2.86^\circ$  horizontally and  $7.63^\circ$  vertically and the hash marks measured  $235 \times 175$  pixels and subtended a visual angle of  $4.39^\circ$  horizontally and  $5.92^\circ$  vertically from a viewing distance of 60cm. Examples of the stimuli can be seen in Figure 6.1.

### *Procedure*

Participants saw the starting grid with a square highlighted in red for 3000ms. They then saw a series of arrows presented serially in sequence lengths of 2, 3 or 4 arrows. The hash marks were placed in between the arrows where necessary to make the trial durations uniform. Each stimulus arrow or hash mark was presented for 1500ms each. Participants were instructed to navigate around the grid starting at the start location highlighted in the starting grid, using the arrows to guide them. Each arrow denoted a movement of one square in a particular direction on the grid. When the response grid was shown, participants were required to respond “g” for correct and “k” for incorrect. Responses were made vocally using a microphone. Figure 6.1 shows the pattern of each trial. The sensitivity of the microphone was checked prior to the start of the experiment to ensure responses were being encoded. Participants then completed a practice block of eight trials before going onto the experimental block. The practice trials ran on a loop until eighty percent of the responses were correct.

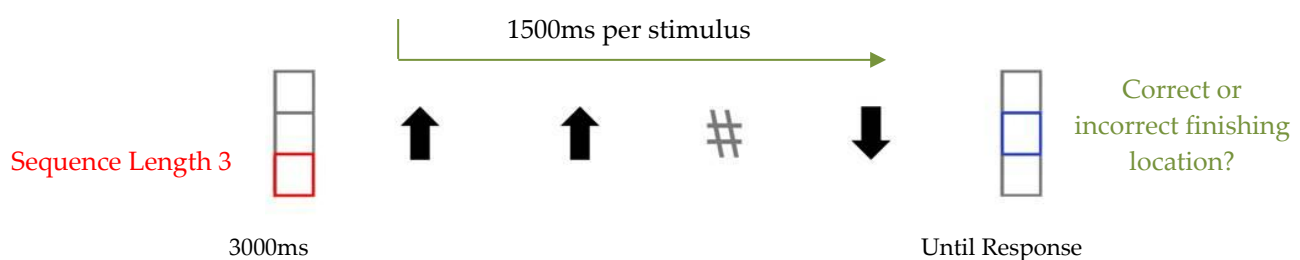

**Figure 6.1. Trial representation of Visual Vector Transformation Task.**

## **Task 2: Auditory Transformation Task**

### *Stimuli*

The stimuli consisted of three 1x3 (135 x 405 pixels) starting grids, each with one square outlined in red. There were three response grids which were the same as the starting grids but with a square outlines in blue. The grids subtended 4.58° horizontally and 14.81° of visual angle vertically. There were also three sound files, a tone at 330Hz, 660Hz, and a white noise sound.

### *Procedure*

Prior to the start of the experiment, participants were shown an example of a trial to familiarise themselves with the task. The tones were played to the participants and participants were required to correctly identify the high pitched tone and the low pitched tone by responding “high” or “low” into the microphone, thus also checking that the microphone was accurately detecting voice onset times. The trial begun with a starting grid representing a starting location presented for 3000ms. This was preceded by a sequence of high (660Hz), low (330Hz) and white noise tones presented for 1500ms each. The high tones denoted an upwards movement and the low tone denoted a downwards movement. The trial structure can be seen in Figure 6.2. The white noise was presented when the same tone was presented as a space filler to ensure trial durations were uniform. When the response grid was shown, participants were required to respond “g” for correct and “k” for incorrect. Responses were made vocally using a microphone. The sensitivity of the microphone was checked prior to the start of the experiment to ensure responses were being encoded. Participants then completed a practice block of a minimum of eight trials before going onto the experimental block. Participants were required to achieve an eighty percentage accuracy level on practice trials before proceeding to the experimental block.

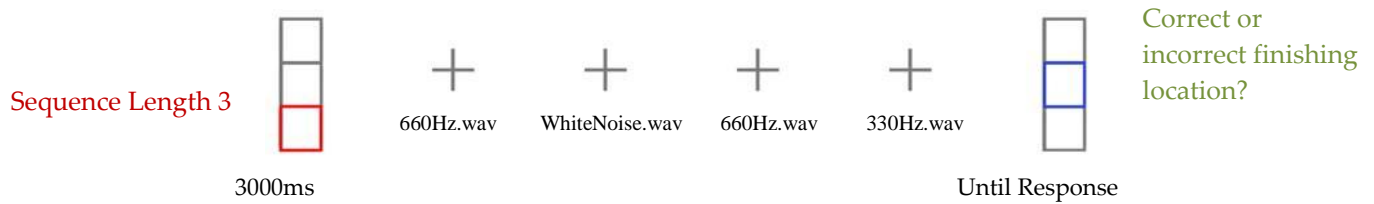

**Figure 6.2. Visual representation of trial structure for auditory vector transformation task.**

## Results

Voice onset times (VOTs) and accuracy were recorded for each experiment. VOTs for incorrect trials as well as those for VOTs 2 SDs above the mean for each condition were excluded from the analysis, (Visual Vector Transform = 10.83%, Auditory Vector Transform = 11.25%). The percentage accuracy data underwent arcsine square root transformation (Sokal & Rohlf, 1981) and the VOT data underwent Log10 transformation to normalise the data prior to statistical analysis.

### Accuracy Analysis

A 2(Group) x 2(Task) x 3(Sequence Length) mixed ANOVA on percentage accuracy showed significant main effects of group  $F(1,62)=6.23$ ,  $p = .015$ ,  $\eta^2 = .10$ , Task,  $F(1,62) = 4.73$ ,  $p = .033$ ,  $\eta^2 = .07$ , and sequence length  $F(2,124) = 62.15$ ,  $p < .001$ ,  $\eta^2 = .50$ . Thus, the PD group ( $M = 85.03$ ,  $SD = 10.74$ ) made more errors than the control group ( $M = 87.01$ ,  $SD = 9.27$ ). There was also significant two-way sequence length\*task interaction  $F(2,124) = 3.31$ ,  $p = .04$ ,  $\eta^2 = .05$  and a three-way interaction between sequence length\*group\*task  $F(2,124) = 10.49$ ,  $p < .001$ ,  $\eta^2 = .15$ . There were no other significant effects. Mean percentage accuracy for each task across sequence length conditions can be seen in Figure 6.3. In light of the three-way interaction, the tasks were explored further by conducting separate ANOVAs for each task.

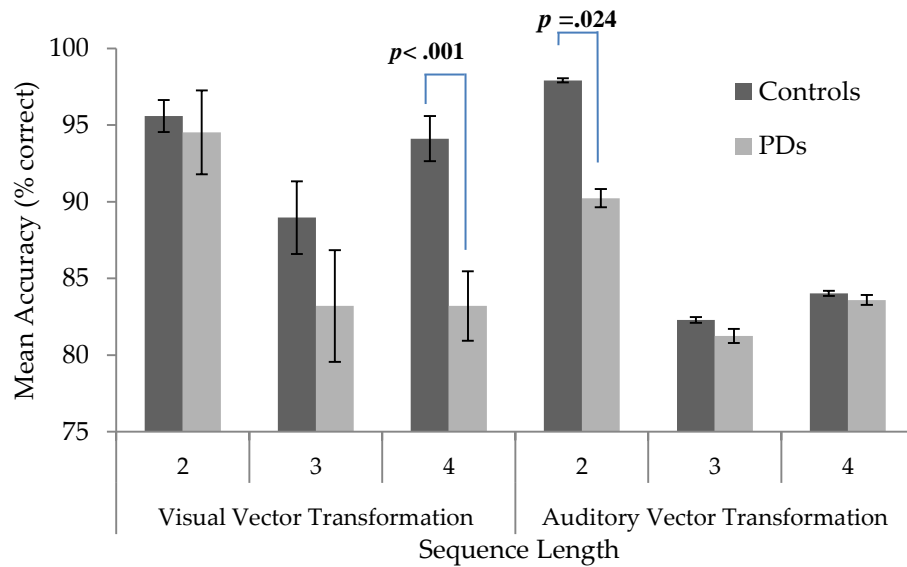

Figure 6.3. Mean percentage accuracy between groups across Sequence Length and Task. Error bars represent standard error of the mean.

### Visual Vector Transformation Task

A 2(Group)  $\times$  3(Sequence Length) ANOVA on accuracy data showed a significant main effect of group  $F(1,31) = 4.35, p = .045, \eta^2 = .12$  and a main effect of sequence length  $F(2,62) = 17.73, p < .001, \eta^2 = .36$ . There was also a significant interaction between group\*sequence length  $F(2,62) = 7.15, p = .002, \eta^2 = .19$ . Though the controls ( $M = 92.89, SD = 4.78$ ) were more accurate than the PD group ( $M = 88.54, SD = 2.41$ ) as shown by the main effect of group, the two groups only significantly differed on sequence length 4  $F(1,31) = 20.08, p < .001, \eta^2 = .39$  (Controls:  $M = 94.12, SD = 6.04$ , PD:  $M = 83.20, SD = 9.05$ ).

### Auditory Vector Transformation Task

A 2(Group)  $\times$  2(Sequence Length) mixed ANOVA on percentage accuracy showed a significant main effect of sequence length  $F(2,62) = 52.00, p < .001, \eta^2 = .63$ , but no effect of group,  $F(1,31) = 1.98, p = .17, \eta^2 = .06$ . There was a significant two way interaction between group\*sequence length  $F(2,62) = 5.03, p = .009, \eta^2 = .14$ . Planned comparison analyses showed that the control and PD group only differed in accuracy on sequence length 2,  $F(1,31) = 5.68, p = .024, \eta^2 = .16$  (Controls:  $M = 97.79, SD = 4.39$ , PD:  $M = 90.23, SD = 14.96$ ).

### **VOT Data Analysis**

A 2(Group) x 2(Experiment) ANOVA showed a main effect of group  $F(1,62) = 5.78, p = .019, \eta p^2 = .085$  showing that the PD group ( $M = 1212.54, SD = 398.72$ ) were slower at responding than the control group ( $M = 1014.18, SD = 171.38$ ). There was no effect of task and no group\*task interaction. No further analyses were conducted as the research question concerns the task\*group difference.

### **The individual level of analysis**

The individual participant accuracy scores can be seen in Figure 6.4. The group level analysis suggests that PD patients are only impaired in visual vector transformation but this might mask theoretically relevant variation at the individual subject level. To address this, the Crawford modified t test (Crawford & Howell, 1998; Crawford & Garthwaite, 2002) was applied to each individual PD patient for each experiment. This statistic enables the individual patient score to be compared against a control sample and is sensitive to the size of the control sample. . The individual patient level of analysis showed variations within the PD group. In total, 4/16 patients showed significant deficits at the individual subject level.

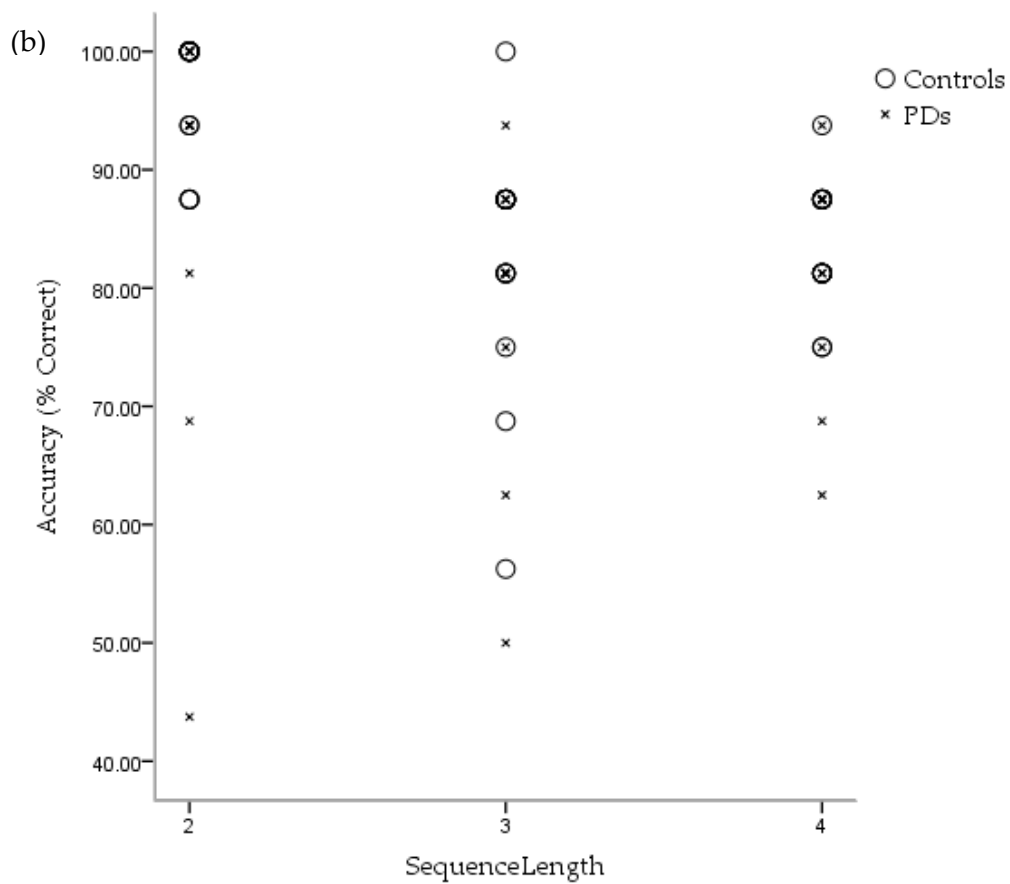
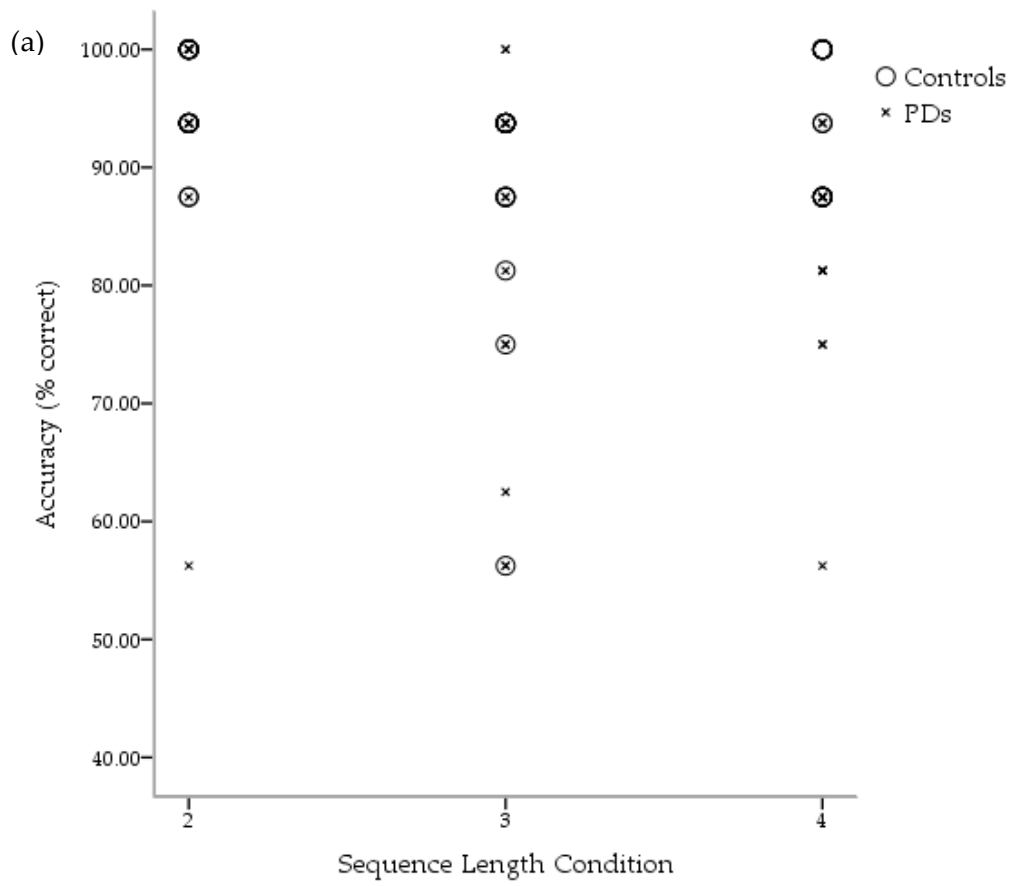
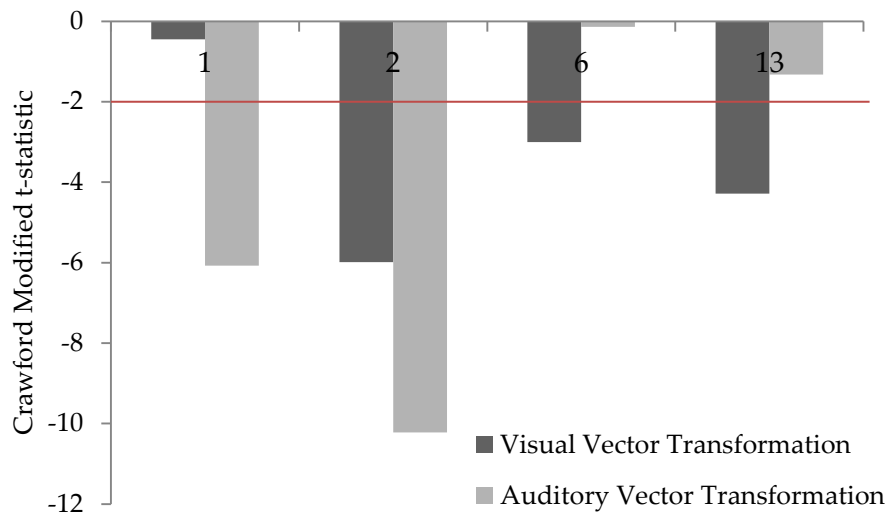

Figure 6.4. Scatter plots showing percentage accuracy data for the Control and PD groups on (a) Visual Vector Transformation Task and (b) Auditory Vector Transformation Task.



**Figure 6.5. Individual performances of the Parkinson's disease patients who showed impairments on any of the vector transformation tasks. Values represent t-test values of the Crawford Modified t-test designed to compare single cases to a control sample.**

The performance of patients who demonstrated any impairment on either task can be seen in Figure 6.5. Three patients showed abnormal performance on visual vector transformation and two patients were impaired at auditory vector transformation. PD 6 and PD 13 show impairments exclusive to visual vector transformation, while PD 1 shows a deficit only in auditory vector transformation. Impairment on both tasks was observed in PD 2. Thus, at the individual subject level, there is evidence of a double dissociation between tasks.

Bivariate correlations of the individual PD patient scores on the two transformation tasks and neurological screening data can be seen in Table 6.2. Significant relationships can be seen between average accuracy on the two transformation tasks. Average Accuracy on auditory vector transformation is also correlated with average accuracy on the same task and with the WASI verbal subset. The visual vector transformation task showed significant correlations between VOTs and performance on the Hohen and Yahr Scale, participant's age, performance on the BVRT, WASI performance subset IQ and WASI full IQ. VOTs on the auditory transformation task correlated significantly with performance on MMSE and the BVRT.





## Discussion

The main findings from the study are that at the group level of analysis, the PD patient group and control group differed significantly on performance in the visual vector transformation task but not on the auditory transformation. Supporting the group level of analysis, the individual patient data suggest dissociation between the visual and auditory modalities. There are also suggestions of a double dissociation with PD 1 demonstrating impaired performance on the auditory transformation task despite intact visual vector transformation. The poor performance was not a result of a physical hearing impairment or a misunderstanding of the task as established in correct practice trial performance.

One possibility for this pattern of results is that there is an amodal vector transformation system restricted to the visual modality on the basis that three out of the four patients showing any deficit, did so on visual vector transformation. However, the presence of a deficit specific to the auditory task suggests domain specific transformation systems. Thus, pre-SMA may recruit vector transformation from independent, domain specific processing pathways.

An alternative explanation for better performance on the auditory task than the visual task may be because performance on the auditory task is not affected by the sustained visual attention deficit in PD (Lee, Wild, Hollnagel & Grafman, 1999; Maddox, Filoteo, Delis, & Salmon, 1996). More specifically, the impairments in PD associated with directing, sustaining or relocating the focus of visual attention (Baldo, Mota & Silva, 2006) are likely to have led to impaired performance on the visual task. Unlike the visual transformation task, the auditory task can be successfully completed without sustained visual attention.

Impaired visual vector transformation in this study is consistent with previous research indicative of spatial remapping deficits in PD (Kerai et al., 2012; Study II). On the

hypothesis that impaired visual vector transformation is a result of pre-SMA dysfunction, it is of interest to consider how participants who demonstrated visual vector transformation impairments performed on auditory vector transformation. Of the three patients who showed abnormal performance in the visual domain, the impairments on both tasks is observed in one patient suggesting that visual and auditory vector transformations selectively affected the cognitive processes.

Support for such conclusions comes from investigations of auditory and visual spatial localization in humans which found modality specific activation during spatial localization tasks (Bushara et al., 1999). This research also supports the double dissociation between visual and auditory spatial deficits, that is, auditory impairments occurring in the absence of visual cues and vice versa (De Renzi, Gentilini, & Barbieri, 1989; Soroker, Calamaro, Glickson, & Myslobodsky, 1997). Thus while both vector transformation tasks involve pre-SMA, the visual and auditory modalities may recruit spatial transformation processes differently.

It can be argued that pre-SMA activation during the two tasks is due to condition action associations (Nachev et al., 2007) where responses are associated, to some degree, with an arbitrary stimulus rule. However whether the cues were presented visually or audibly, the conditioned responses to the stimuli were the same and required imagined navigational movements around a reference frame. Furthermore, the arbitrariness of the auditory stimulus items suggests that the visual task would be easier. However the group level deficit in visual vector transformation suggests that the strength of any stimulus-response mapping cannot explain the results, supporting the notion of modality independent pathways to pre-SMA.

Further analysis of the data with the screening data found significantly positive correlations between accuracy on visual vector transformation and auditory vector transformation. This may have been because most of the patients performed on both tasks within the normal range. A positive correlation between VOTs on visual vector transformation and motor impairment measured by Hoen and Yahr score is not surprising given that motor slowing is likely to manifest in slower responses. Interestingly, as VOTs get faster on the visual vector transformation task, WASI performance IQ increases, suggesting that performance on this WASI subset can predict speed of visual vector transformation. However, the block design component of the WASI is scored on speed of task completion. As such it is likely that this measure of cognitive processing speed is related to the speed of processing in the visual vector transformation task. However, no such relationship was apparent for the auditory vector transformation task suggesting that the visual characteristics of the WASI performance subset account for such associations with visual vector transformation. Accuracy on auditory vector transformation was higher for those participants who scored higher on the verbal subset of the WASI. Pre-SMA has been associated with a range of linguistic tasks including word generation (Abrahams et al., 2003; Alario, Chainay, Lehericy, & Cohen, 2006; Tremblay & Gracco, 2006; Etard et al., 2000), sentence production (Kemeny et al., 2005; Haller, Radue, Erb, Grodd, & Kircher, 2005) and story-telling, a complex form of spoken language production (Braun, Guillemin, Hosey, & Varga, 2001). It is possible in this instance that verbal subsets of the WASI were sensitive to pre-SMA disruption. Thus taken together, the performance on auditory vector transformation and verbal IQ may reflect the diverse functional contribution of pre-SMA to these tasks.

The individual patient level of analysis shows that the PD patient population is not heterogeneous in terms of functional deficits. The varied presentation of PD gives rise to clinical diversity within the diagnosis and has important implications for research investigating the effects of PD. Clinical heterogeneity has been commonly observed in PD (Bostantjopoulou, Logothetis, Katsarou & Mentenopoulos, 1991; Graham & Sagar, 1999; Lewis et al., 2005; Zetuský, Jankovic, & Pirozzolo, 1985) and several attempts have been made to identify clinical subtypes in PD but the findings have been inconclusive and have failed to consistently identify homogeneous subtypes (Graham & Sagar, 1999; Lewis et al., 2005; Schrag, Quinn, & Ben-Shlomo, 2006). Cognitive impairment is one phenotype investigated in the classification of PD subtypes (Goldman, Weis, Stebbins, Bernard, & Goetz, 2012), though the findings remain inconclusive. An area that remains to be explored is the exact nature of the patient level variation observed in the vector transformation tasks. With a broader range of PD patients, patterns may emerge enabling us to better identify the clinical subtypes and elucidate the nature of the impairment.

Individual variation in the PD group demonstrates how group level analyses can mask theoretically and clinically significant variation in performance. In light of the present results, we conclude that PD patients can demonstrate impairments of vector transformation processes in visual and auditory domains and that these can show double dissociations. The double dissociation suggests that visual and auditory vector transformations are independent processes. Though pre-SMA computes vector transformation, the double dissociations suggest that visual and auditory information accesses vector transformation processes via separate processing pathways.

## Chapter 7

# An investigation of pre-SMA activation during cognitive rehabilitation to improve motor reaching in Parkinson's disease

### Chapter Overview

The previous studies have shown that Parkinson's disease (PD) can be associated with deficits in visuospatial transformation. The aim of this final study was to investigate whether training in visuospatial transformation tasks can ameliorate motor symptoms in PD.

There is an increasing need to develop non-pharmacological treatments to address the symptoms of PD. Examples of cognitive training programs in PD have demonstrated improvements in cognitive function supporting the rationale for further developing cognitive training in PD (Sammer, Reuter, Hullmann, Kaps, & Vaitl, 2006). In addition, improvements to motor symptoms of PD have been greater when therapeutic programs include cognitive training supporting the previously identified associations between mental and manual functions and their overlapping neural substrates (Sammer et al., 2006). This relationship has previously been exploited in neurofeedback techniques (Subramanian et al., 2011) and repetitive transcranial magnetic stimulation (rTMS) over supplementary motor areas (SMA; Fregni, Simon, Wu & Pascual-Leone, 2005; Hamada, Ugawa, & Tsuji, 2009). These studies support SMA as a site for preferential activation for therapeutic effects.

Study IV compared the effect of a vector transformation task and a sequence memory task on simple motor reaching. By hypothesis, the vector transformation task activated pre-SMA while the sequence memory task did not. The performance of PD patients did not differ from the control group in the behavioural tasks. Modest improvements were seen in movement velocity following the vector transformation task but not after the sequence

memory task. This pattern of results suggests that activation of pre-SMA via a cognitive task improved movement planning and visuomotor-associations which impact visuospatial coordinate mapping. The results provide further evidence for targeting pre-SMA for therapeutic gains using an inexpensive, theoretically motivated, abstract imagery task.

## **Introduction**

As medical research advances, PD patients are living longer and experiencing greater difficulties as a result of cognitive impairment. Thus, there is a growing need to therapeutically address the cognitive effects of PD. There is a greater interest in non-pharmacological treatments given the cost and side effects of pharmacological medication.

The key aim of cognitive rehabilitation is to administer a behavioural intervention which targets a particular impairment which currently prevents an individual from carrying out activities of daily living in an attempt to improve the impairment. The basic premise of cognitive rehabilitation consists of basic training related to performance and is usually targeted to specific cognitive domains (Cicerone, Dahlberg, Kalmar et al., 2000). At present, there is no treatment directed against the cause of PD. Though medical and surgical treatments lead to symptomatic benefits, these benefits do not address all symptoms highlighting the need for further treatment considerations.

To date, there have been few successful treatments for cognitive dysfunction in PD and medical trials focussing on delaying the progression of cognitive decline or improving cognitive impairment have had variable success (Vale, 2008; Kehagia, Barker, & Robbins, 2010). Behavioural interventions that can improve motor or cognitive impairment have the potential to improve quality of life for PD patients. Sammer et al., (2006) compared PD patients before and after they completed a standard rehabilitation program consisting of

occupational therapy, physiotherapy and physical treatment in conjunction with a cognitive training program involving the Battery of behavioural Assessment of Dysexecutive Syndrome, a Cognitive Estimation Test, that required participants to make quantitative judgements which are not factually determined e.g. how tall is a houseplant, and a Trail Making Task. Patients who underwent the cognitive training program alongside the standard rehabilitation program improved executive function skills compared with PD patients who completed the standard rehabilitation in isolation (Sammer, Reuter, Hullmann, Kaps, & Vaitl, 2006). These findings support the efficacy of cognitive training on cognitive function in PD. Cognitive rehabilitation therapies are increasingly being recognised as viable alternatives or supplementary to medical treatments to address cognitive impairment, but there is little evidence for the effectiveness of cognitive rehabilitation in PD for addressing motor behaviour (Abbruzzese, Pelosin & Marchese, 2008).

Why do we expect cognitive tasks to impact motor behaviour? Mental and manual movements have shown interference effects when concurrently performed, suggesting that the two processes utilise overlapping neural substrates (Wohlslager & Wohlslager, 1998; Wexler, Kosslyn, & Berthoz, 1998) including premotor cortex, supplementary motor area (SMA), the cingulate cortex, parietal cortex and the cerebellum (Dechent, Merboldt, & Frahm, 2004; Hanakawa et al., 2003; Malouin, Richards, Jackson, Dumas, & Doyon, 2003; Roth et al., 1996; Gerardin et al., 2000). In addition, Study I (Kerai et al., 2012) implicates SMA in spatial remapping via vector transformation processes which underlie the planning and control of visually guided movements as well as abstract cognitive computations such as mental rotation and abstract grid navigation (Study I; Study II). Taken together, these findings suggest that mental movements can impact manual movements as have been demonstrated in mental imagery research.

The impact of mental imagery on motor behaviour in PD reported that PD patients are unable to learn a grapho-motor task using imagery practice and attributed the deficit to dopamine inputs to basal ganglia in PD (Yágüez, Canavan, Lange, Hömberg, 1999). However, greater improvements of bradykinesic symptoms have been observed in patients following combined physical and mental practice than in patients receiving physical practice in isolation (Tamir, Dickstein, & Huberman, 2007) supporting the notion of shared pathways for motor and mental movement and providing a strong case for exploiting this relationship for therapeutic intervention.

A therapeutic technique that has recently been investigated is neurofeedback. This method uses brain imaging methods to illustrate brain activity with a goal to train participants to control brain activity. It is a method of cognitive rehabilitation and has shown positive effects in motor function in PD patients (Subramanian et al., 2011). Through the use of neurofeedback, PD patients successfully learnt to increase SMA activity using motor imagery and improved motor behaviour compared with a sample of PD patients matched for disease severity that completed the task in the same way as the experimental group, but did not receive neurofeedback. These findings support the rationale for using cognitive tasks involving motor imagery to activate pre-SMA with a goal to impact motor symptoms. The neurofeedback study did not specify a form of imagery participants were asked to perform. Rather, participants were asked to imagine “any type of movement”. Given that the free reign of movement imagery produced SMA activity, it is likely that a more structured imagery task targeting pre-SMA which is uniform across participants would be likely to improve motor behaviour. Furthermore, the lack of improvement in the control group suggests that selective activation of SMA without neurofeedback is ineffective. However, it is possible that the group that received neurofeedback were able to increase



SMA activity based on feedback to an effective level while the control group were not cued to achieve a higher and possibly more effective level of activation.

Further evidence of the therapeutic effect of SMA activation comes from studies using rTMS over SMA in PD (Fregni, Simon, Wu, Pascual-Leone, 2005; Hamada, Ugawa, & Tsuji, 2009). In a double blind study, the PD patients who received rTMS over SMA made significant improvements compared with a control group of patients who underwent sham stimulation (Hamada et al., 2009). Though modest, these improvements in motor symptoms of PD patients support SMA as a potential stimulation site for the treatment of PD and also help to justify using PD as a model of SMA dysfunction. But how can targeted activation of pre-SMA impact motor behaviours such as simple cued reaching?

Activation of pre-SMA has been observed during visually guided movement where primates performed two types of reaching tasks; reaching for a sequence of three visually cued targets and reaching for visually cued targets continuously without an inter trial interval (Picard & Strick, 2001; 2003). Interestingly, the authors report that these tasks did not adequately produce distinct activity of SMA and pre-SMA likely to be because the tasks did not require internally generated movements. However, recent imaging studies have reported pre-SMA activity when participants select movements based on external sensory cues including visual and auditory (Kurata et al., 2000; Sakai et al., 1999). This conditional motor behaviour in response to sensory information suggests that pre-SMA maps sensory input to movement (Hoshi & Tanji, 2004). These findings support the role of pre-SMA in calculating spatial coordinates of a location and movement trajectories during the planning, and online control, of action, as well as abstract cognitive tasks like visuospatial transformation.

PD has been consistently associated with visuospatial transformation impairments as described in the preceding chapters with regard to spatial normalisation (Kerai et al., 2012) and grid navigation. The vector transformation hypothesis attributes these impairments to under activity of pre-SMA, and the mechanisms underlying the updating of spatial locations in imagined movements. Given the links identified between mental and manual movement and the consequent success of SMA stimulation on PD motor symptoms, it is hypothesised that by performing a vector transformation task, participants will increase the excitation of pre-SMA. The preferential activation of pre-SMA with a cognitive vector transformation task should improve performance on a motor reaching task compared with a cognitive task which by hypothesis does not activate these specific regions of pre-SMA.

Study IV was designed as a preliminary investigation of the effects of vector transformation processes in pre-SMA with a cognitive task on motor performance in PD measured by an externally cued reaching task. A further aim of Study IV was to re-examine auditory vector transformation. Though impairments were not observed at auditory cued abstract vector transformation in the behavioural paradigm, evidence of vector transformation processes may be observed in the form of improved movement onset and velocity following the vector transformation task. Thus, this chapter further investigates vector transformation in the auditory domain.

This study was a pilot study to assess the feasibility of using this type of cognitive task to impact motor performance with a goal solely of establishing a proof of principle. Performance was measured before and after a cognitive vector transformation task with abstract imagery and an auditory sequence memory task which required no imagery, thus hypothesised not to illicit vector transformation processes in pre-SMA. Improvements of

motor symptoms in PD as a result of a vector transformation will open the door to cognitive rehabilitation strategies in PD which are currently under studied.

## **Methods**

### **Participants**

Sixteen patients diagnosed with idiopathic Parkinson's disease were recruited from a North Wales PD Clinic upon recommendation for suitability by their neurologist (Mean = 63.38; Range = 51-78; SD = 7.82; Mean disease duration = 9.19yrs, F = 5; M = 11).

Seventeen age and sex matched control participants were also recruited via a local volunteer panel. Both the patient and control groups were made up of different participants from those in previous chapters. The exclusion criteria for all participants were no history of mental illness and no other neurological complications other than PD. Prior to testing, the research was approved by the NHS and University ethics committees in accordance with the Declaration of Helsinki.

### **Neuropsychological Background and Screening Tests**

The Mini Mental State Exam (MMSE; Folstein et al., 1975) was used to assess the degree of cognitive dysfunction in PD patients. The Hoen and Yahr (1967) scale provided a description of the progression of Parkinsonian symptoms. Visual memory was measured by the Benton Visual Retention Test (BVRT, Benton, 1992). The Weschler Abbreviated Scale of Intelligence (WAIS; 1999) was administered to measure verbal and performance intelligence. A detailed description of the PD sample, clinical sub-type is shown in Table 7.1.

**Table 7.1. Mean control and individual patients' scores on screeners.**

Screeners	Control		PD															
	Mean(SD)	Mean (SD)	PD1	PD2	PD3	PD4	PD5	PD6	PD7	PD8	PD9	PD10	PD11	PD12	PD13	PD14	PD15	PD16
Gender			M	F	M	F	M	M	M	F	F	M	M	M	M	M	F	M
Subtype*			T	A/R	M	M	A/R	M	M	M	M	T	M	A/R	M	T	T	T
Medication Type**			DA	DA/DR	DA/DR	DR	DA/DR	DA	DA/DR	DA/DR	DA/DR	DA/DR	DA	DA/DR	DA	DA/DR	DA/DR	DA
H&Y		2.25 (0.58)	2	2	1	2	2	2	2	2	2	3	2	3	3	3	3	2
Disease duration (yrs)		9.19 (4.10)	8	5	7	7	11	10	7	4	11	7	8	15	21	9	10	7
Age	62.4(3.86)	63.38 (7.82)	67	51	58	63	64	53	63	51	70	68	59	65	64	78	76	64
MMSE	29.71(0.59)	29.44 (0.89)	28	30	30	30	29	30	30	30	30	27	29	30	30	29	29	30
BVRT	7.41(1.37)	6.5 (1.41)	4	8	6	6	6	8	7	8	5	5	8	7	5	6	6	9
WASI Verbal IQ	124.88(8.65)	123.93 (9.76)	104	133	114	134	128	111	127	113	127	117	136	121	128	125	127	138
WASI Performance IQ	121.88(12.50)	114.25 (15.72)	99	135	120	128	101	133	131	109	108	109	134	105	123	79	104	110
WASI Full 4 IQ	125.53(10.13)	120.25 (17.65)	101	139	119	135	115	125	116	113	119	115	140	115	128	100	117	127

\* Classification into subtypes of PD. Tremor dominant (T), Akinetic/Rigid (A/R), Mixed (M)

\*\* Medication Type. Dopamine Agonists (DA); Ropinirole, Pramipexole or Amantadine; Dopamine Replacement (DR); Sinemet

## **Stimuli**

### *Visual Stimuli*

The stimulus items included a grey 1 x 3 (135 x 405 pixels) grid which subtended a visual angle of 14.80° vertically and 5.16° horizontally. Three grey starting grids had the same parameters as the blank grid but each had a different square highlighted in red. The response grids were the same as the starting grids but each with a different square highlighted in blue. A grey central fixation cross (150 x 150 pixels) subtended 4.58° visual angle horizontally and vertically. Examples of the visual stimuli can be seen in Figures 7.2 and 7.3.

### *Auditory Stimuli*

There were three audio tones. A high frequency tone (660 Hz) a low frequency tone (330Hz) and a white noise tone.

## **Apparatus**

Stimuli were presented in E-prime 1.2 (Psychology Software Tools Inc. Pittsburgh, USA) on a 17 inch monitor at a screen resolution of 1024 x 768 pixels at a viewing distance of 50cm. Visual responses were recorded using a microphone and a serial response box (Psychology Software Tools Inc. Pittsburgh, USA).

A light cue board was designed to measure movement onset and velocity of simple reaching. The board had a trajectory of 3 touch sensitive copper rods at 30° angular variances which were each 45cm away from the starting switch. A diagram of the movement board can be seen in figure 7.1. Each rod was 10cm high with a red LED at the top. The movement board was executed by MatLab via a parallel port.

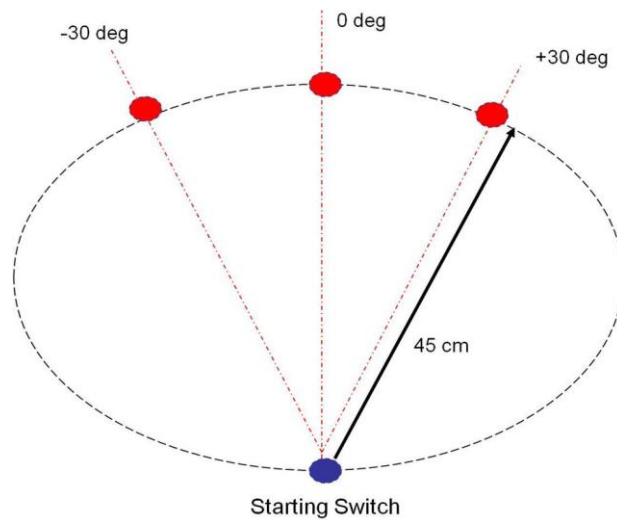

**Figure 7.1** A scientific diagram of the Light Cue Box.

## **Behavioural Experimental Tasks**

### *Auditory Vector Transformation Task*

The starting grid was presented with one of the squares highlighted in red signifying the starting location on the grid. After 3000ms, the starting grid was replaced by a central fixation cross. A series of 5 sounds was then played each for 750ms separated by a silence of 350ms. The series of tones was made up of 2, 3 or 4 of the high and low frequency tones. The white noise sound was a placeholder to ensure the trial lengths remained uniform across sequence length conditions. The low frequency tone denoted a movement of one square down on the grid and the high frequency tone denoted a movement of one square up on the grid. The white noise required no movement. Participants were instructed to mentally navigate up and down the grid as guided by the tones and note which square would be the correct finishing location. When the response grid was presented, participants responded whether the finishing location on the grid was correct or incorrect if the tones were followed correctly. Participants responded “right” if the finishing location was correct and “wrong” if the finishing location was incorrect. The response grid remained on the screen until a vocal response had been recorded.

There were 48 trials altogether, 16 trials per sequence length condition. Half the trials required a correct response and half of the trials required an incorrect response. The trials were separated into 2 blocks of 24. Participants initiated the start of each trial. A practice block of 8 trials was administered before the experimental block began. There was also a short computerised task before the experiment where participants responded whether the sound they heard denoted an upwards or downwards movement to establish that the participants understood the condition action associated with the sounds and to check that participants were able to distinguish between the high and low tones.

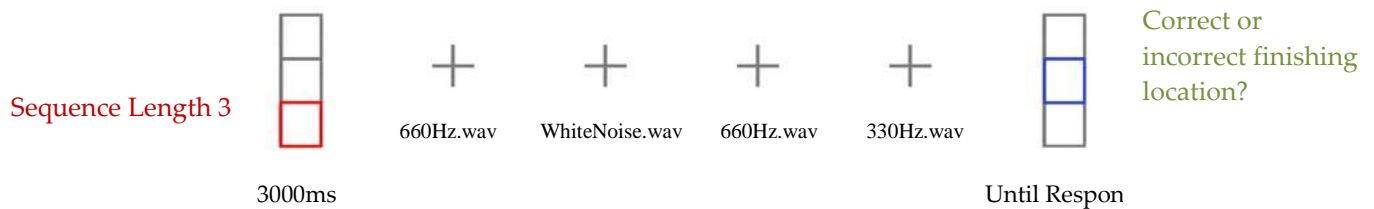

**Figure 7.2. Trial presentation of Auditory Vector Transformation Task.**

### *Auditory Sequence Memory Task*

The blank grey grid was presented for 3000ms to signify the start of the trial. Then the fixation cross appeared as shown in Figure 7.2, while a series of 2, 3 and 4 tones were played. During the trials for sequence length 2 and 3, a white noise sound was played in addition to the tones to ensure the trial lengths matched those of the sequence length 4 condition.. After the initial sequence of tones had been played, the blank grid was presented again and the sequence of tones was played back omitting the white noise. Participants responded whether the second series of tones was the same or different from the first series of tones without the white noise. Participants responded “same” if the two sequences were the same and “different” if the sequences were different.

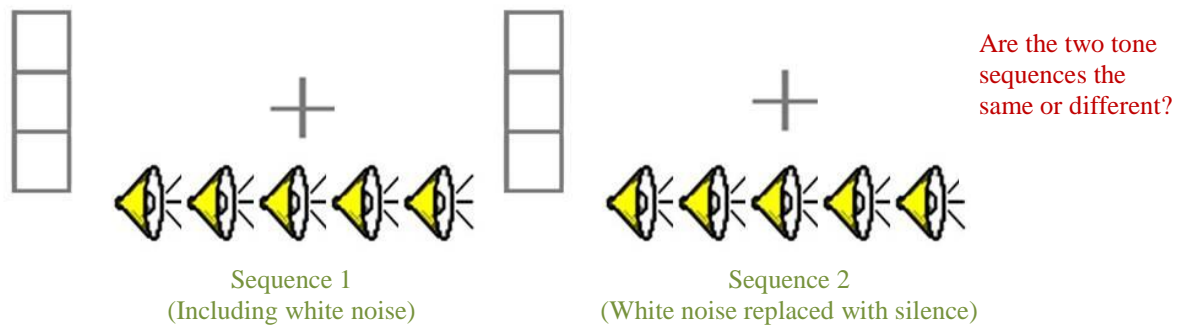

**Figure 7.3. Trial presentation of Auditory Sequence Memory Task.**

### **Motor Reaching Task**

The movement board, controlled by Matlab, monitored the onset of the light which was randomised between 1500ms and 3000ms after the starting switch was pressed. Participants pressed the starting switch to begin the trial. When one of the light rods was illuminated, participants were instructed to release the starting switch and reach for and touch the rod as quickly as possible. The program measured the movement onset from when the light came on and the release of the switch for movement initiation and reaction time from the release of the switch to a touch which was used to calculate movement velocity.

Measures were taken of left and right hands. There were thirty trials on each hand.

### **General Procedure**

The motor reaching task was performed before (Pre-test) and after (Post-test) each of the behavioural tasks as illustrated in Figure 7.4. The auditory vector transformation and auditory sequence memory tasks were administered on separate occasions and the order of the tasks as well as the order of hands were counterbalanced across participants.





**Figure 7.4. General task order for motor reaching task with both intervening task structures.**

## Results

The voice onset times (VOTs) for incorrect trials and VOTs 2 standard deviations above the mean were excluded from the analysis. The VOT data were log<sub>10</sub> transformed to meet the assumptions of normality and the percentage accuracy data were transformed using the arcsine square root correction (Sokal & Rohlf, 1981).

### Analysis of Behavioural Experimental Tasks

A 2(Task: Auditory Vector Transformation Vs Auditory Sequence Memory) × 2(group:

Control Vs PD) × 3(sequence length: 2, 3 and 4) mixed ANOVA showed significant effects of

Task,  $F(1, 64) = 73.64, p < .001, \eta_p^2 = .54$  and sequence length,  $F(2, 128) = 15.44, p < .001, \eta_p^2 =$

.19. There was no significant effect of group,  $F(1, 64) = 2.77, p = .101, \eta_p^2 = .04$ . There was a

significant two way interaction of task\*sequence length  $F(2, 128) = 33.35, p < .001, \eta_p^2 = .34$

and a significant three way interaction of task\*group\*sequence length,  $F(2, 128) = 5.79, p = .004, \eta_p^2 = .08$ .

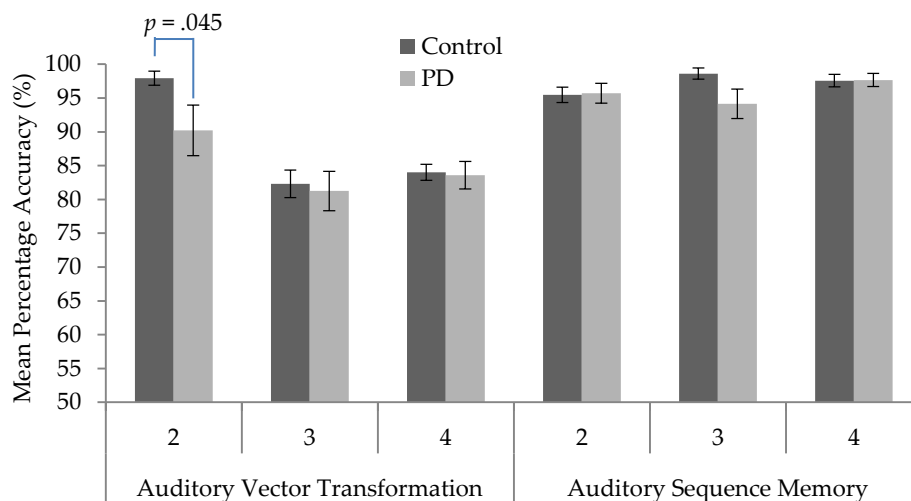

**Figure 7.5. Mean percentage accuracy for the two behavioural tasks across the three sequence length conditions. Error bars show standard error of the mean.**

The significant interactions were explored with further one way ANOVA for each task. The Auditory Vector Transformation task had a significant effect of sequence length

$F(2, 64) = 55.62, p < .001, \eta_p^2 = .64$ . There was no significant effect of group,  $F(1, 32) = 2.24, p =$

.14,  $\eta_p^2 = .07$ . The two way sequence length\*group interaction was significant,  $F(2, 64) = 5.53$ ,  $p = .006$ ,  $\eta_p^2 = .15$ . The two groups only differed significantly on sequence length 2  $t(32) = 2.51$ ,  $p = .017$ ,  $d = 0.9$ .

A one way ANOVA on the auditory sequence memory task showed no significant effects of sequence length  $F(2, 64) = 1.64$ ,  $p = .203$ ,  $\eta_p^2 = .050$ , or group,  $F(1, 32) = .686$ ,  $p = .414$ ,  $\eta_p^2 = .021$ . The two way sequence length\*group interaction did not reach significance,  $F(2, 64) = 2.25$ ,  $p = .114$ ,  $\eta_p^2 = .07$ .

### **Analysis of Motor Reaching**

Given the variation in performance reported in the previous chapter and to specifically explore how robust any observed effects are, the PD patient performance was investigated at the individual patient level. To establish how the individual PD patients differed from the control group, percentage improvement was calculated for each participant. Crawford modified t tests (Crawford & Howell, 1998; Crawford & Garthwaite, 2002) were then computed on the patient percentage improvement scores based on the control mean and standard deviation. These revealed that 4/16 (25%) of patients showed improvement following the vector transformation task and 1/16 showed an improvement after the sequence memory task. These findings can be seen in Figures 7.6 and 7.7.

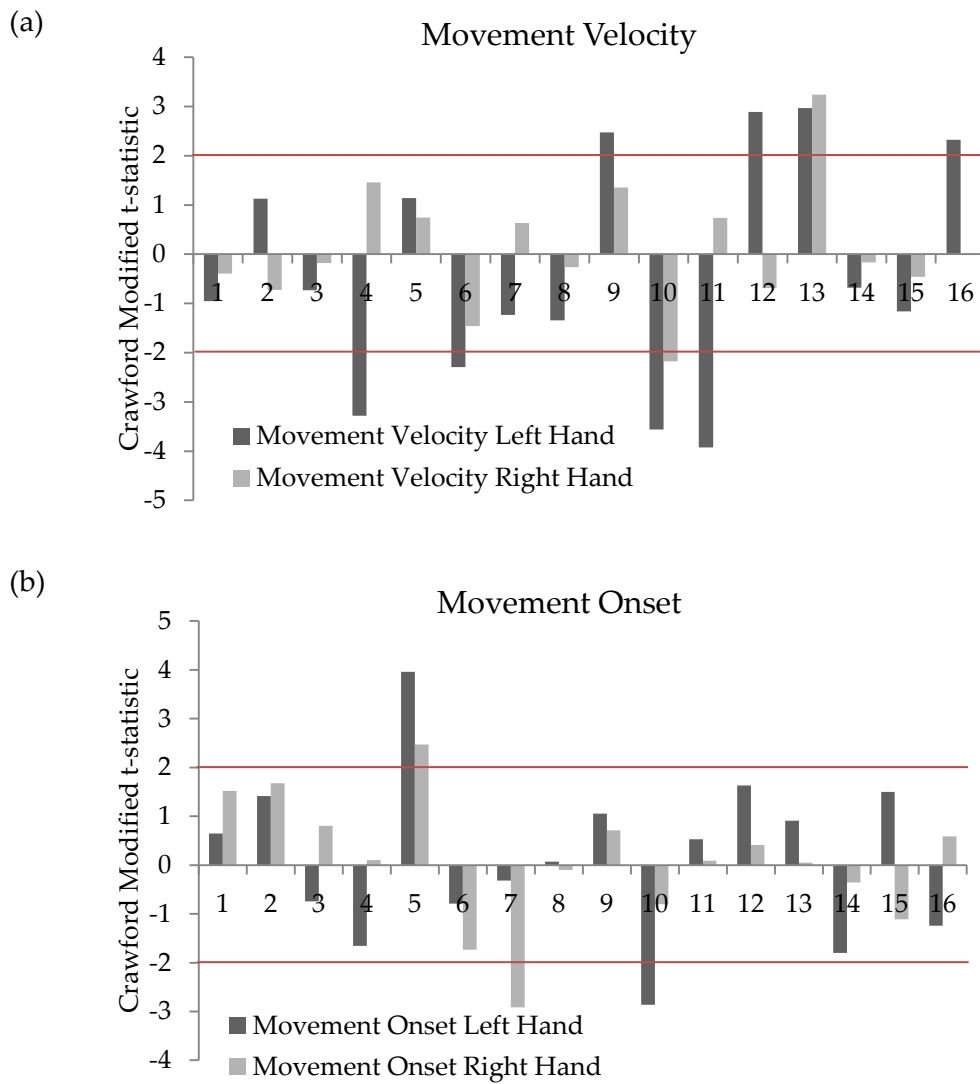

Figure 7.6. Crawford Modified t statistic on percentage improvement for individual patient performance on Auditory Vector Transformation: (a) Movement Velocity , (b) Movement Onset.

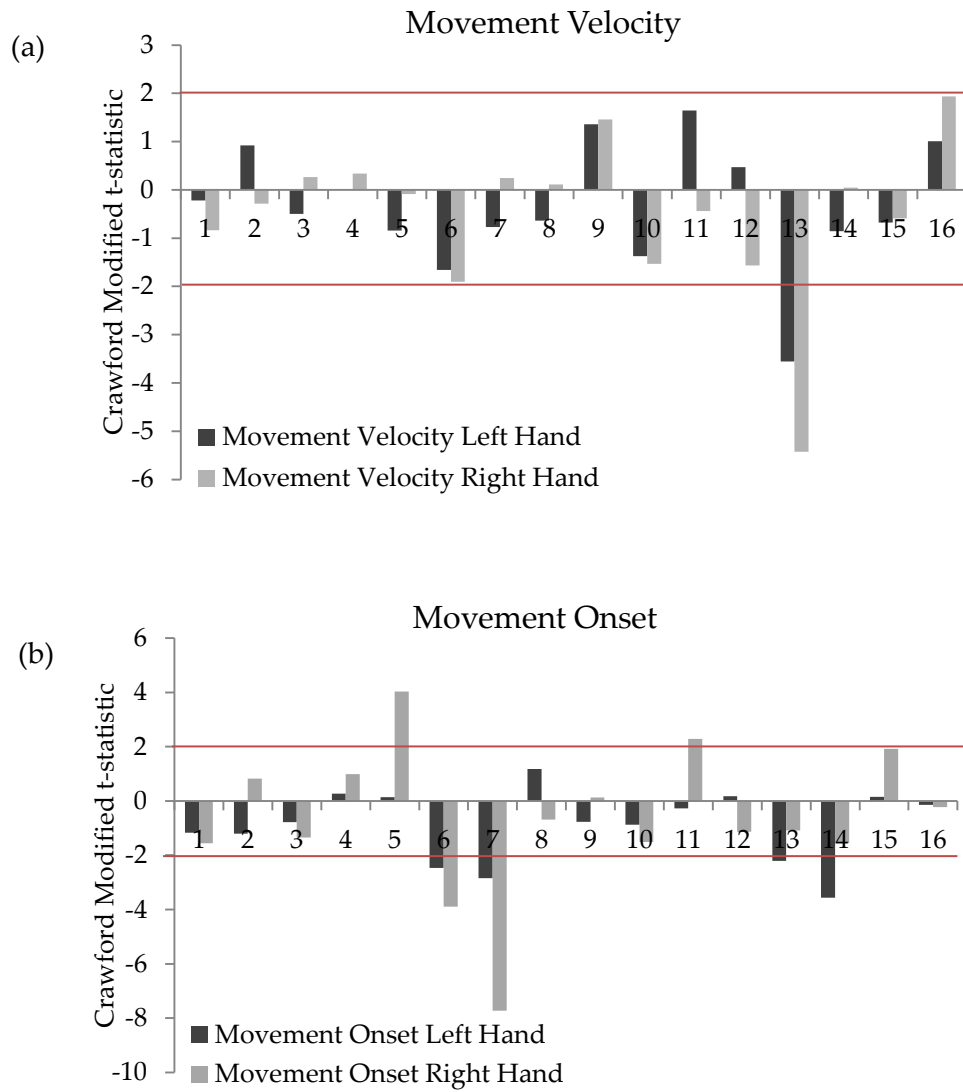

Figure 7.7. Crawford Modified t statistic on percentage improvements for individual patient performance on Auditory Sequence Memory task: (a) Movement Velocity, (b) Movement Onset.



---

---

---

### **Correlation Analysis**

The bivariate correlations between motor behaviour and screening data can be seen in Tables 3 and 4 for the Auditory Vector Transformation task and the Auditory Sequence Memory Task respectively. BVRT scores were correlated with MMSE scores. Hoehn and Yahr measures were significantly correlated with disease severity and age. Age correlated with various cognitive screeners.

Bivariate correlations of screening data with motor behaviour on auditory vector transformation showed significant correlations between Movement Onset of the left and right hands, Velocity of the left and right hands and between Velocity on the left hand with Movement Onset on both hands.

Significant relationship was also shown between Movement Onset of the right hand and performance on the BVRT. On the auditory vector transformation task, significant correlations were seen between Movement Onset of the right and left hands, right hand Movement Onset and disease duration and Velocity of the right and left hands.

### **Discussion**

The findings from the behavioural experiments showed that PD patients and controls did not differ in their performance on the auditory vector transformation task or the auditory sequence memory task. The motor reaching analysis shows that 25% of the patients demonstrated improvements of movement velocity following the auditory vector transformation task while only one patient made velocity improvements after the sequence memory task. One explanation for improvement following vector transformation is that the task improved the spatial remapping of physical movement.

Though it remains unclear why these patients make significant improvements while others do not, the importance of clinical heterogeneity in PD is further highlighted here. No



patients made significant improvements on movement onset or movement velocity after the sequence memory task with the exception of patient 5, further supporting the distinction between the experimental and control task. Improvements of velocity after vector transformation are supported by the functional correlates of bradykinesia in PD recruiting premotor areas including pre-SMA (Turner, Grafton, McIntosh, DeLong & Hoffman, 2003). The lack of significant improvement on movement onset on either task suggests that vector transformation may not affect movement initiation or planning processes in simple externally guided reaching. The reaching task described in this study relies on externally guided movement, the movement preparation of which is presumed to be mediated by SMA proper. The role of pre-SMA in visually guided movement is hypothesised to be in the modulation of visuo-motor association (Sakai et al., 1999). The improvements of velocity in PD following the vector transformation task suggest that pre-SMA may mediate vector transformation, that is, enhanced vector transformation processes initiated by the transformation task would suggest improvements in visuospatial mapping, manifesting in improved visually guided reaching.

These findings are important because they suggest that cognitive therapy can improve movement velocity in some PD patients. Although the results suggest that the auditory vector transformation task only affected performance in some patients, it is important to consider in the context of this study, that these patients show selective improvements on this task which requires vector transformation and not on the auditory sequence memory task. Not only does this confirm that the auditory sequence memory task is a suitable control task but also supports the notion that vector transformation leads to improvements in movement velocity. It is implied that pre-SMA may govern the processes that compute abstract vector transformation and highlight the association between mental and manual movement (Wexler, 1998).

Consistent with previous investigations, vector transformation hypothesised to recruit pre-SMA improved motor function in PD (Fregni et al., 2005; Hamada et al., 2009). Similarly, attempts at stimulating SMA using imagery have also produced motor improvements (Subramanian et al., 2011). However, unlike previous research, the current study empirically measures motor behaviour pre and post-test providing a more reliable level of improvement.

Correlation analyses showed that movement onset and velocity across both hands significantly correlated on both tasks suggesting that improvements did not selectively favour a particular hand. The relationship between velocity and movement onset suggested by the correlations on the auditory transformation task could reflect the effects of vector transformation on motor performance. Pre-SMA has traditionally been associated with pre-movement activity such as movement onset and planning. If the excitation of pre-SMA via spatial vector remapping improved movement onset, it is also likely to have improved the vector transformation processes underlying visually guided reaching supporting the role of pre-SMA in vector transformation. The Hoen and Yahr scale is a measure of motor impairment. It is expected that as the disease progresses, motor impairment in PD becomes more severe. Motor functions are sensitive to aging and are likely to be more disrupted in older participants accounting for the correlations between motor impairment and aging. Like motor function, cognitive functions are also subject to the effects of aging. It is therefore not surprising that age correlated with visual perception on the BVRT or subsets of the WASI.

### **Clinical Implications**

Though in its early stages, the current study has important clinical implications for rehabilitation in Parkinson's disease. The current methods are inexpensive and quick,

making them a viable alternative to rTMS, fMRI or neurofeedback in improving motor symptoms in PD.

There is a current lack of research on the long term effects of mental practice on physical performance in tasks which rely on mental imagery. It would be interesting to investigate how long the motor improvements produced vector transformation can be seen. As such, delayed follow up assessments would enable us to conclude whether or not the effects of mental practice are pervasive and result in progressive improvement.

Several factors could have contributed to the variation within the PD patient group. It has been well documented that PD is a heterogeneous group with variations in medications, primary symptoms and severity of symptoms.

Future research should establish the cause of the individual variation within the PD group. Though several attempts have been made to classify the clinical subtypes of PD, the findings remain equivocal. It may be of interest to test PD patients in the "OFF" stage of medication to establish how the function of pre-SMA is affected by dopaminergic medication. Research argues that Levodopa therapy restores SMA function to normal in medicated PD patients (Rascol et al., 1994). Testing unmedicated patients would give us a better idea of pre-SMA dysfunction. In addition, using fMRI techniques to measure the activity of pre-SMA in PD patients whilst performing these vector transformation tasks, would enable us to make more specific conclusions about the precise role of pre-SMA in vector transformation. The present study builds on previous research indicating pre-SMA disruption in PD. Results from rTMS studies imply that SMA is an acceptable site to target for remediation of motor symptoms in PD (Fregni, Simon, Wu & Pascual-Leone, 2005; Hamada, Ugawa, & Tsuji, 2009). The improvements seen in motor symptoms of bradykinesia following a vector transformation task suggest that cognitive rehabilitation is adequate to impact motor function. These improvements are encouraging and demonstrate

that the paradigm should be further investigated with the hope of developing an effective tool for PD motor symptom management.

## Chapter 8

### General Discussion

The aim of the thesis was to investigate the contribution of supplementary motor areas in spatial vector transformation using Parkinson's disease (PD) patients as a model of SMA dysfunction. PD patient performance on visuospatial transformation tasks has been inconsistent (Kemps et al., 2005; Pillon et al., 1998; Lee et al., 1998; Levin, Llabre & Weiner, 1991; Sawamoto et al., 2002; Stelmach, Phillips & Chau, 1989; Stoffers, Berendse, Deijen, & Wolters, 2003). One explanation for the discrepant findings in previous work is that the range of visuospatial tasks utilise additional cognitive demands such as image normalisation, spatial memory or the sequential chaining of information.

This thesis tests the spatial vector transformation hypothesis of pre-SMA (Johnston & Leek, 2009). According to this view, one function of pre-SMA in movement planning and control is the remapping of coordinates from one spatial location to another within a transformation matrix. A clear prediction of the vector transformation hypothesis is deficits in PD because PD has consistently been associated with under activity of the anterior SMA or pre-SMA (Fukuda et al., 2001; Sabatini et al., 2000; Thobias et al., 2000; Cunnington et al., 2001) thought to be the result of result of the selective loss of dopaminergic nigral input to the putamen which increases inhibition of the excitatory drive from the thalamus (Cunnington et al., 2001; Braak, et al., 1996)

It has been proposed that mental rotation or spatial normalisation times reflect the remapping of spatial vectors from one coordinate location to another (Leek & Johnston, 2009). Imaging research suggests that spatial transformation processes involve medial premotor regions ( Johnston et al., 2004; Lamm et al., 2001; Richter et al., 2000; Vingerhoets et al., 2001; Windischberger et al., 2003) which are known to be affected by PD. If the PD deficit in visuospatial transformation is a result of a disruption of this vector mapping

process, abnormal spatial normalisation rates were expected. Study I investigated how PD affected spatial normalisation and whether spatial normalisation impairments generalise across two spatial transformation tasks: mental rotation and recognition memory.

Findings showed that PD patients demonstrated significantly steeper regression slopes and thus slower spatial normalisation rates than controls on both transformation tasks though the PD group had steeper slopes on the mental rotation task than on recognition memory. Task demands are higher when comparing two visible stimulus items (mental rotation) than when matching stimuli to stored mental representations (recognition memory). The spatial normalisation deficit is consistent with the hypothesis that premotor regions, more specifically pre-SMA, play a role in spatial transformation. The magnitude of visuospatial transformation deficit in PD was modulated by task suggesting that visuospatial processes underlying mental rotation are distinct from those required to recognise misoriented objects. The study concluded that PD patients demonstrate vector remapping impairments required for spatial normalisation.

Though these findings support existing literature of a visuospatial transformation deficit in PD, the precise nature of the deficit remains unclear. One explanation for the inconsistency in the literature is the impact of additional cognitive processes required to complete the task (Kemps, Szmalec, Vandierendonck, & Crevits, 2005; Pillon et al., 1998; Sawamoto et al., 2002; Stoffers, Berendse, Deijen, & Wolters, 2003). It is of interest what short term spatial memory and sequence processing contribute to visuospatial deficits in PD. Sequence processing impairments in PD have been associated with pre-SMA dysfunction (Kennerley, Sakai, & Rushworth, 2004; Nakamura, Sakai, & Hikosaka, 1998; Hikosaka et al., 1999). The role of pre-SMA in the selection and organisation of sequential movements has been further extended to the processing of abstract sequences including visuospatial sequencing.

Unlike the vector transformation of an image frame rotation as described in Study I, the spatial mapping of locations with a reference frame also enlists vector transformation. Of interest is how the spatial remapping impairments in PD observed in spatial normalisation extend to other visuospatial transformation tasks. Study II investigated PD patient ability to encode and retain memory for spatial locations. Spatial vector transformation was also investigated under simultaneous and sequential viewing conditions. Finally sequential vector transformation was compared with sequential subtraction to establish the contribution of visuospatial transformation in performance on sequential processing tasks.

The PD patients had normal memory for spatial locations. They were however, impaired at sequential vector transformation. This deficit cannot be accounted for by sequential task demands because the PD patients performed normally on the sequential number subtraction task which differed only in its non-spatial transformation component.

Study II concluded that visuospatial transformation deficits in PD are not directly the result of compromised sequential information processing or memory for visual spatial locations. Cognitive effects of PD can include mechanisms that support visuospatial vector transformation in pre-SMA which are affected by nigro-striatal dopamine depletion in PD.

Visual and auditory stimuli help us to interpret and interact with our environment. Both modalities enable us to determine distance and direction. We already demonstrated vector transformation processes modulated by visual stimuli in Study II. Therefore, Study III investigated vector transformation processes in the auditory stimulus modality to determine whether vector transformation is domain general.

Support for pre-SMA modulating both auditory and visual vector transformation comes from neuroimaging research showing equal activation of pre-SMA during visual and auditory tasks (Sakai, Stepniewska, Qi, & Kaas, 2000). The aim of Study III was to investigate the domain generality of spatial mapping processes by comparing the performance of PD

patients and controls on a visual and auditory vector transformation task. If vector transformation processes in PD were domain specific impairments were expected only on visual vector transformation. Impairments on both transformation tasks would imply that vector transformation in pre-SMA is domain general.

At the between group level of analysis, the PD group showed significant differences compared with controls on the visual transformation task but not on the auditory transformation task suggesting domain specificity in favour of the visual domain. However, the individual level of analysis showed that two of the patients who demonstrated impairments on visual vector transformation were also impaired at auditory vector transformation. These cases demonstrated that vector transformation is domain general. It is also suggested that one function of pre-SMA is the computation of abstract vector transformation. The double dissociation suggested that vector transformation in the visual and auditory domains utilise independent processing pathways. Also highlighted was the clinical heterogeneity in the PD patient sample which will be discussed in more detail later.

Existing research supports the efficacy of cognitive training on cognitive function in PD (Sammer, Reuter, Hullmann, Kaps, & Vaitl, 2006). Though cognitive therapy is becoming increasingly recognised as an alternative to or as a supplement to medical treatment, there have been few successful studies of cognitive treatments in PD addressing motor behaviour.

The interference effects of concurrent manual and mental movements suggest overlapping neural substrates including SMA (Wohlslager & Wohlslager, 1998; Wexler, Kosslyn, & Berthoz, 1998). Given the links between manual and mental movement and the shared activation of pre-SMA in both these processes it was hypothesised that preferential activation of pre-SMA with a cognitive task (such as the previously described transformation tasks) would produce more improvements in motor behaviour compared with a non-pre-SMA activating cognitive task. The findings showed that PD patients



performed worse on the auditory vector transformation task than on the auditory sequence memory task supporting the assumption that PD is associated with vector transformation processes in the auditory domain.

Consistent with our previous findings of clinical heterogeneity, not all PD patients showed significantly greater improvements compared with the control group. However, more PD patients made improvements on movement velocity after the vector transformation task than movement onset. The findings suggest that vector transformation processes produce modest improvements of bradykinesia in some PD patients measured by visually guided reaching. The study concluded that vector transformation processes can be applied as a method of cognitive rehabilitation to show improvements in motor speed in some PD patients.

## **8.1 Impaired Visuospatial Transformation in PD**

In this series of experiments, investigations of visuospatial ability in PD are made from a number of perspectives: mental rotation, spatial navigation, spatial memory and visual spatial attention. The studies attempt to address some of the basic mechanisms underlying spatial perception.

Previous research investigating visuospatial transformation in PD has been criticised for involving complex manipulations of stimuli relative to the self (Lee et al., 1998). The authors did not report impairments of transformations in the two dimensional image plane but the results were based on reaction times which may not be a true measure of visuospatial function as they have added decision making processes. Spatial normalisation rates consider the cognitive processes underlying image transformations. The speed of rotation between angular disparities are considered together to give a general speed of rotation at ms/deg. These processes applied in the first study, provide a more reliable

measure of cognitive processing. The PD patient group demonstrated impaired spatial normalisation rates and these findings were replicated when matching an image representation to a previously stored internal representation. Thus, PD impairment as a function of spatial normalization is not accountable to additional cognitive components of the task.

Visuospatial transformation impairments in route finding and navigation have been attributed to an inability to invert body image to interpret a map (Semmes et al., 1963). As with the visuospatial transformation task discussed above, the task required the spatial manipulation of the self and does not therefore provide a pure measure of navigation ability. Though previous research has investigated grid navigation in PD, there was not enough emphasis placed on the visuospatial processes involved (Sawamoto et al., 2002).

The visual vector transformation task described in Chapter 5 attempted to look more closely at abstract navigational processes. The impaired performance of PD patients on this visuospatial task is further indicative of a visual spatial transformation deficit in PD. Further, additional task demands and their influence on performance of abstract navigation were addressed. The impairments observed were not a result of a spatial working memory deficit or a temporal sequence processing impairment. Thus, PD appears to be associated with visuospatial impairment at the basic navigation level.

Comparisons of visually guided transformations and audibly guided transformation showed that PD patient impairments were sensitive to visuospatial as well as audio spatial transformation. Thus, the current findings support visuospatial disruptions in PD in the form of inflated spatial normalisation rates and erroneous visuospatial abstract navigation. But what does pre-SMA contribute to the deficit?

## 8.2 The Vector Transformation Hypothesis

One proposed function of pre-SMA has been in the computation of spatial vector mapping. The vector transformation hypothesis assumes that pre-SMA involvement in spatial transformation is not through specific motor planning operations but through abstract spatial vector transformations used in motor and non-motor tasks where the remapping of abstract spatial locations (Leek and Johnston, 2009).

PD is of interest when investigating SMA function because of its connectivity with the basal ganglia pathways affected by PD (Mink, 1996) and has consistently been associated with under activity in PD (Nachev et al., 2008). Visuospatial transformation impairments in PD are presumed to be a result of disrupted activation of SMA and pre-SMA. Reduced activity of pre-SMA was hypothesised to impair vector transformation processes.

Study I recruited vector transformation in remapping the location of stimulus parts to make same/different judgements and in mapping spatial coordinates from an internal image representation with those of an external representation. Vector transformation processes were shown to be impaired in both spatial normalisation tasks. The purpose of Study II in testing the vector transformation hypothesis was to investigate whether vector transformation processes observed in spatial normalisation extend to other visuospatial transformation tasks. If vector transformation processes can be applied to a range of visuospatial tasks, the contribution of vector transformation to the visuospatial transformation impairment in PD can be confirmed. Consistent with this hypothesis, PD was associated with visual vector transformation impairment. Furthermore, vector transformation processes extended to visuospatial transformation guided by auditory cues.

Following the finding that not all PD patients demonstrated impairment on visual vector transformation, the individual level of performance was considered in the two

dimensional vector transformation tasks reported in Study I. Of the thirteen patients who completed the task, 10 of the patients showed abnormal performance compared with the control group, indicative of an impairment. This 2D visual vector transformation task is more sensitive to impairments than the version presented Study III. The one dimensional vector transformation tasks are easier and require the remapping of vectors in a single polarity, which can explain this pattern of results. Future investigations could further explore this aspect of dimension.

The relationship between imagined movement and physical movement in pre-SMA was exploited in the motor rehabilitation pilot study where the impact of potential pre-SMA re-excitation with vector transformation is reported. The underlying function of pre-SMA proposed by the vector transformation hypothesis is spatial mapping in both the motor and non-motor domain. The proposed association between mental and manual movement together with the improvements made in motor behaviour following mental vector transformation support the hypothesis that pre-SMA modulates spatial vector remapping between coordinate locations in imagined and physical movement.

Further investigations of this paradigm could determine the precise nature of the improvements associated with pre-SMA activation. In addition, it is necessary to clarify the involvement of pre-SMA in PD patients during these vector transformation tasks. It has been suggested that compensatory neural mechanisms may exist in PD (Appel-Cresswell, de la Fuente-Fernandez, Galley, & McKeown, 2010; van Nuenen, Helmich, Ferraye et al. 2012). As such, it would be of interest to investigate the neural mechanisms activated during vector transformation tasks in PD. Findings may confirm involvement of pre-SMA in these abstract imagery and spatial remapping tasks or highlight compensatory processes. Some avenues that remain underexplored are the underlying nature of the individual patient variation. Compensatory mechanisms for impaired basal ganglia function may account for some of the

within patient variability. A larger sample with a greater availability of demographic information may help to identify certain behaviours associated with visuospatial and visuomotor behaviour. In addition it would be of interest to establish how long the positive effects of vector transformation on movement velocity last. A delayed follow up assessment can determine whether the effects of mental stimulation are pervasive. Also of interest is whether vector transformation improvements can be successfully applied to motor functions other than simple reaching, particularly in the context of complex sequential reaching. Given the previously identified contribution of pre-SMA to internally generated movement, it is likely that such a complex internally guided movement task would produce more robust effects.

### **8.3 Clinical Heterogeneity in Parkinson's disease**

Given the varied presentation of PD observed in patients, the heterogeneity of PD is becoming increasingly well recognised and can be seen in the PD sample recruited for these studies.

A potential confound of the present studies which may contribute to the variation of performance within the PD patient group is medication. All the patients were on a different course of medication for their PD symptoms tailored to their needs in different doses. Though attempts were made to match the PD group to medication type and motor impairment, the effect of medication on PD performance was difficult to control for. In addition to medication type, the time of day testing took place; particularly in terms of the time relative to the last dose of medication. Furthermore, "wearing off" is a frequently reported experience in PD when medical relief begins to wane. This wearing off is quite often unpredictable and may account for some of the variations in performance.

With regards to medication in PD, research suggests that PD patients medicated with Levodopa have normal function of SMA by up regulation of the dopaminergic system though such normalisation has only been partially reported (Rascol et al., 1994). These findings suggest that PD patients tested in the “OFF” stage of medication may provide a more valid opportunity to investigate the effects of SMA dysfunction.

Previous research into rehabilitative strategies has reported the efficacy of combined therapy in addressing both motor and cognitive functions (Sammer et al., 2006). Some patients who participated in these studies were also engaged in alternative therapies to improve their functionality including yoga programmes, physical exercise programmes and one patient reported regularly using techniques acquired from previous research to address some motor symptoms with imagery.

Studies of the relationship between cognitive measures and motor UPDRS performance suggest that motor symptom severity but not disease duration significantly correlated with cognitive impairment (Williams et al., 2007). Motor symptoms have further been implicated in cognitive impairment with research finding that right sided motor symptom onset was associated with better cognitive function compared with left sided symptom onset. Thus clinical symptom onset may be a more reliable predictor of cognitive impairment in PD than later motor symptom presentation (Tomer, Levin, & Weiner, 1993; Katzen, Levin, & Weiner, 2006).

Research investigating the progression of cognitive impairment in PD showed that cognitive decline progresses faster in older patients, patients who were older at disease onset and patients in the later stage of the disease (Stepkina, Zakharov, & Yakhno, 2010). These findings suggest that from a cognitive perspective, younger patients, patients with younger disease onset and those in the early stages of the disease are likely to have better

cognitive functioning. The clinical samples studied in this thesis are likely to fall within a vast spectrum of cognitive impairment accounting for such varied performance.

Thus it can be seen that there are a variety of reasons which could explain the variant performance within the PD group. Attempts at classifying subtypes of PD based on factors such as motor features, cognitive impairment, disease duration, symptom onset and rate of progression of the disease, and age of onset have not been consistently reliable (Marras & Lang, 2012). Findings from experimental paradigms such as those presented in the studies presented in the thesis may assist with this clinical classification. It is important that research into PD considers the PD patient group heterogeneously and applies caution to conclusions based on group levels of analysis.

#### **8.4 Summary and Conclusions**

The main aims of the thesis were to investigate the contribution of pre-SMA to vector transformation using PD patients as a model of pre-SMA dysfunction. PD patients and controls performed a series of vector transformation tasks. PD patients showed deficits in visuospatial transformation tasks including mental rotation, abstract grid navigation and visual and auditory transformation tasks. These deficits cannot be accounted for by visuospatial memory or sequence processing. Together, these results support the vector transformation hypothesis. Pilot results showed how this model of vector transformation and pre-SMA motivates non-pharmacological cognitive rehabilitation in PD.

## References

- Abbruzzese, G., Pelosin, E., & Marchese, R. (2008). Current Problems and Strategies in Motor Rehabilitation for Parkinson's Disease *Advances in Alzheimer's and Parkinson's Disease*, 57, 23-30. doi: 10.1007/978-0-387-72076-0\_4
- Abrahams, S., Goldstein, L. H., Simmons, A., Brammer, M. J., Williams, S. C. R., Giampietro, V. P., et al. (2003). Functional magnetic resonance imaging of verbal fluency and confrontation naming using compressed image acquisition to permit overt responses. *Human Brain Mapping*, 20, 29-40. doi:10.1002/hbm.10126
- Akkal, D., Dum, R. P., & Strick, P. L. (2007). Supplementary Motor Area and Presupplementary Motor Area: Targets of Basal Ganglia and Cerebellar Output. *The Journal of Neuroscience*, 27, 10659-10673. doi:10.1523/JNEUROSCI.3134-07.2007
- Alain, C., & Bernstein, L. J. (2008). From sounds to meaning: the role of attention during auditory scene analysis. *Current Opinion in Otolaryngology & Head and Neck Surgery*, 16, 485-489. doi:10.1097/MOO.0b013e32830e2096
- Alario, F. X., Chainay, H., Lehericy, S., & Cohen, L. (2006). The role of the supplementary motor area (SMA) in word production. *Brain Research*, 1076, 129-143. doi:10.1016/j.brainres.2005.11.104
- Alexander, G. E., & Crutcher, M. D. (1990). Functional architecture of basal ganglia circuits: neural substrates of parallel processing. *Trends in neurosciences*, 13, 266-271. doi:10.1016/0166-2236(90)90107-L
- Alexander, G. E., DeLong, M. R. & Strick, P. L. (1986). Parallel Organization of Functionally Segregated Circuits Linking Basal Ganglia and Cortex. *Annual Review of Neuroscience*, 9, 357-381. doi: 10.1146/annurev.ne.09.030186.002041



- Altmann, C. F., Bledowski, C., Wibral, M., & Kaiser, J. (2007). Processing of location and pattern changes of natural sounds in the human auditory cortex. *NeuroImage*, *35*, 1192-1200. doi:10.1016/j.neuroimage.2007.01.007
- Altmann, L. J. P., & Troche, M. S. (2011). High-Level Language Production in Parkinson's disease: A Review. *Parkinson's Disease*. doi:10.4061/2011/238956
- Alvarez, J., & Emory, E. (2006). Executive Function and the Frontal Lobes: A Meta-Analytic Review. *Neuropsychology Review*, *16*(1), 17-42. doi: 10.1007/s11065-006-9002-x
- Amick, M. M., Schendan, H. E., Ganis, G., & Cronin-Golomb, A. (2006). Frontostriatal circuits are necessary for visuomotor transformation: Mental rotation in Parkinson's disease. *Neuropsychologia*, *44*, 339-349. doi:10.1016/j.neuropsychologia.2005.06.002
- Arthurs, O. J., Johansen-Berg, H., Matthews, P. M., & Boniface, S. J. (2004). Attention differentially modulates the coupling of fMRI BOLD and evoked potential signal amplitudes in the human somatosensory cortex. *Experimental Brain Research*, *157*, 269-274. doi:10.1007/s00221-003-1827-4
- Baddeley, A. D. (1986). *Working Memory*. Oxford: Oxford University Press.
- Bahlmann, J., Schubotz, R. I., Mueller, J. L., Koester, D., & Friederici, A. D. (2009). Neural circuits of hierarchical visuo-spatial sequence processing. *Brain Research*, *1298*, 161-170. doi:10.1016/j.brainres.2009.08.017
- Baldo, M. V., Mota, A. M., & Silva, K. C. (2006). The allocation of endogenous visual attention in Parkinson's disease. Paper presented at the ECVF.
- Bates, J. F., & Goldman-Rakic, P. S. (1993). Prefrontal connections of medial motor areas in the rhesus monkey. *The Journal of Comparative Neurology*, *336*, 211-228. doi:10.1002/cne.903360205

Bayles, K. A., Tomoeda, C. K., Wood, J. A., Cruz, R. F., Azuma, T., & Montgomery, E. B.

(1997). The effect of Parkinson's disease on language. *Journal of Medical Speech & Language Pathology*, 5, 157-166.

Bear, M. F., Connors, B. W., & Paradiso, M. (2007). *Neuroscience: Exploring the brain* (Third ed.). PA: Lippincott Williams & Wilkins.

Belger, A., Puce, A., Krystal, J. H., Gore, J. C., Goldman-Rakic, P., & McCarthy, G. (1998).

Dissociation of mnemonic and perceptual processes during spatial and nonspatial working memory using fMRI. *Human Brain Mapping*, 6, 14-32. doi:

10.1002/(SICI)1097-0193(1998)6:1<14::AID-HBM2>3.0.CO;2-O

Benecke, R., Day, B. L., Dick, J. P. R., Marsden, C. D., Rothwell, J. C. (1985) Performance of various types of simultaneous movements in patients with Parkinson's disease.

*Journal of Physiology*, 30, 369, Retrieved from:

<http://e.guigon.free.fr/rsc/article/BeneckeEtAl86a.pdf>

Benton Sivan, A. 1992. *Benton Visual Retention Test*, 5th, San Antonio: The Psychological Corporation.

Boller, F., Passafiume, D., Keefe, N. C., Rogers, K., Morrow, L., & Kim, Y. (1984).

Visuospatial impairment in Parkinson's disease: Role of perceptual and motor factors. *Archives of Neurology*, 41, 485-490.

doi:10.1001/archneur.1984.04050170031011.

Bond, J. M., & Morris, M. E. (2000). Goal-directed secondary motor tasks: Their effects on gait in subjects with Parkinson disease. *Archives of Physical Medicine and*

*Rehabilitation*, 81, 110-116. doi:10.1053/apmr.2000.0810110

Bondi, M. W., & Kaszniak, A. W. (1991). Implicit and explicit memory in Alzheimer's disease and Parkinson's disease. *Journal of Clinical and Experimental Neuropsychology*, 13(2),

339-358. doi: 10.1080/01688639108401048

- Bondi, M. W., Kaszniak, A. W., Bayles, K. A., & Vance, K. T. (1993). Contributions of frontal system dysfunction to memory and perceptual abilities in Parkinson's disease. *Neuropsychology, 7*, 89-102.
- Bostantjopoulou, S., Logothetis, J., Katsarou, Z., & Mentenopoulos, G. (1991). Clinical observations in early and late onset Parkinson's disease, *Functional Neurology, 6*, 145-149.
- Botvinick, M. M., Braver, T. S., Barch, D. M., Carter, C. S., & Cohen, J. D. (2001). Conflict monitoring and cognitive control. *Psychological Review, 108*, 624-652. doi: 10.1037/0033-295X.108.3.624
- Bowen, F. P., Burns, M. M., Brady, E. M., & Yahr, M. D. (1976). A note on alterations of personal orientation in Parkinsonism. *Neuropsychologia, 14*, 425-429. doi:10.1016/0028-3932(76)90071-3
- Braak, H., Braak, E., Yilmazer, D., de Vos, R. A. I., Jansen, E. N. H., & Bohl, J. (1996). Pattern of brain destruction in Parkinson's and Alzheimer's diseases. *Journal of Neural Transmission, 103*, 455-490. doi:10.1007/BF01276421
- Bradley, V. A., Welch, J. A., & Dick, D. J. (1989). Visuospatial working memory in Parkinson's disease. *Journal of Neurology, Neurosurgery and Psychiatry, 52*, 1228-1265. doi:10.1136/jnnp.52.11.1228
- Braun, A. R., Guillemin, A., Hosey, L., & Varga, M. (2001). The neural organization of discourse: An H215O-PET study of narrative production in English and American Sign Language. *Brain, 124*, 2028-2044. doi: 10.1093/brain/124.10.2028
- Brown, R. G., & Marsden, C. D. (1986). Visuospatial function in Parkinson's disease. *Brain, 109*, 987-1002. doi:10.1093/brain/109.5.987

- Brown, R. G., & Marsden, C. D. (1990). Cognitive function in Parkinson's disease: from description to theory. *Trends in the Neurosciences*, 13, 21. doi:10.1016/0166-2236(90)90058-I
- Brown, R. G., Soliveri, P., & Jahanshahi, M. (1998). Executive processes in Parkinson's disease random number generation and response suppression. *Neuropsychologia*, 36, 1355-1362. doi:10.1016/S0028-3932(98)00015-3
- Bryden, M. P. (1982). *Laterality: Functional Asymmetry in the Intact Brain*. New York: Academic Press.
- Bundesen, C., Larsen, A., & Farrell, J. E. (1981). Mental transformations of size and orientation. In J. Long & A. Baddeley (Eds.), *Attention and performance*. Hillsdale, NJ: Erlbaum.
- Bushara, K. O., Weeks, R. A., Ishii, K., Catalan, M. J., Tian, B., Rauschecker, J. P., et al. (1999). Modality-specific frontal and parietal areas for auditory and visual spatial localization in humans. *Nature neuroscience*, 2, 759-766. doi: 10.1038/11239
- Buytenhuijs, E. L., Berger, H. J. C., Van Spaendonck, K. P. M., Horstink, M. W. I. M., Borm, G. F., & Cools, A. R. (1994). Memory and learning strategies in patients with Parkinson's disease. *Neuropsychologia*, 32, 335-342. doi:10.1016/0028-3932(94)90135-X
- Canavan, A. G. M., Passingham, R. E., Marsden, C. D., Quinn, N., Wyke, M., & Polkey, C. E. (1989). The performance on learning tasks of patients in the early stages of Parkinson's disease. *Neuropsychologia*, 27, 141-156. doi: 10.1016/0028-3932(89)90167-X
- Chaudhuri, K. R., Healy, D. G., & Schapira, A. H. V. (2006). Non-motor symptoms of Parkinson's disease: diagnosis and management. *The Lancet Neurology*, 5(3), 235-245. doi: 10.1016/S1474-4422(06)70373-8

- Chung, G. H., Han, Y. M., Jeong, S. H., & Jack, C. R. (2005). Functional Heterogeneity of the Supplementary Motor Area. *American Journal of Neuroradiology*, *26*, 1819-1823.  
Retrieved from: <http://www.ajnr.org/content/26/7/1819.full.pdf>
- Cicerone, K. D., Dahlberg, C., Kalmar, K., Langenbahn, D. M., Malec, J. F., Bergquist, T. F., Felicetti, T., et al. (2001). Evidence-based cognitive rehabilitation: Recommendations for clinical practice, *Archives of Physical Medicine and Rehabilitation*, *81*, 1596-615.  
doi:10.1053/apmr.2000.19240
- Cohen, H., Bouchard, S., Scherzer, P., & Whitaker, H. (1994). Language and verbal reasoning in Parkinson's disease. *Neuropsychiatry, Neuropsychology, & Behavioral Neurology*, *7*, 166-175.
- Cohen, M. S., Kosslyn, S. M., Breiter, H. C., DiGirolamo, G. J., Thompson, W. L., Anderson, A. K., et al. (1996). Changes in cortical activity during mental rotation: a mapping study using functional MRI. *Brain*, *119*, 89-100. doi:10.1093/brain/119.1.89
- Cohen, Y. E., Russ, B. E., & Gifford, G. W. (2005). Auditory Processing in the Posterior Parietal Cortex. *Behavioral and Cognitive Neuroscience Reviews*, *4*, 218-231.  
doi:10.1177/153458230528586
- Colby, C. L., & Goldberg, M. E. (1999). Space and attention in parietal cortex. *Annual Review of Neuroscience*, *22*, 319-349. doi:10.1146/annurev.neuro.22.1.319
- Cools, A. R., van den Bercken, J. H., Horstink, M. W., van Spaendonck, K. P., & Berger, H. J. (1984). Cognitive and motor shifting aptitude disorder in Parkinson's disease. *Journal of Neurology, Neurosurgery, and Psychiatry*, *47*, 443-453.  
doi:10.1136/jnnp.47.5.443
- Cools, R., Stefanova, E., Barker, R. A., Robbins, T. W., & Owen, A. M. (2002). Dopaminergic modulation of high-level cognition in Parkinson's disease: the role of the prefrontal cortex revealed by PET. *Brain*, *125*, 584-594. doi: 10.1093/brain/awf052

- Cooper, J. A., & Sagar, H. J. (1993). Incidental and intentional recall in Parkinson's disease: An account based on diminished attentional resources. *Journal of Clinical and Experimental Neuropsychology*, *15*, 713-731. doi:10.1080/01688639308402591
- Cooper, L. A., & Shepard, R. N. (1973). Chronometric studies of the rotation of mental images. In W.G. Chase (Ed.), *Visual information processing*. New York, NY: Academic Press.
- Cooper, L. A. (1975). Mental rotation of random two-dimensional shapes. *Cognitive Psychology*, *7*, 20-43. doi:10.1016/0010-0285(75)90003-1
- Cooper, L. A. (1976). Demonstration of a mental analog of an external rotation. *Attention, Perception, & Psychophysics*, *19*, 296-302. doi: 10.3758/BF03204234
- Cooper, L. A., & Shepard, R. N. (1978). Transformations on representations of objects in space. In: E. C. Carterette & M. Friedman (Eds.), *Handbook of perception*, (pp. 105-146). New York: Academic Press.
- Cronin-Golomb, A., & Amick, M. (2001). Spatial abilities in aging, Alzheimer's disease and Parkinson's disease. In: F. Boller & S. Cappa (Eds.) *Handbook of Neuropsychology*, (2nd edition, Vol. 6. pp. 119-143). Amsterdam: Elsevier.
- Cronin-Golomb, A., Corkin, S., & Growdon, J. H. (1994). Impaired problem solving in Parkinson's disease: Impact of a set-shifting deficit. *Neuropsychologia*, *32*, 579-593. doi:10.1016/0028-3932(94)90146-5
- Cronin-Golomb, A., & Braun, A. E. (1997). Visuospatial dysfunction and problem solving in Parkinson's disease. *Neuropsychology*, *11*, 44-52. doi:10.1037//0894-4105.11.1.44
- Crawford, J. R., & Garthwaite, P. H. (2002). Investigation of the single case in neuropsychology: Confidence limits on the abnormality of test scores and test score differences. *Neuropsychologia*, *40*, 1196-1208. doi:10.1016/S0028-3932(01)00224-X

- Crawford, J. R., & Howell, D. C. (1998). Comparing an individual's test score against norms derived from small samples. *The Clinical Neuropsychologist*, *12*, 482–486.  
doi:10.1076/clin.12.4.482.7241
- Crucian, G. P., & Okun, M. S. (2003). Visual-spatial ability in Parkinson's disease. *Frontiers in Bioscience*, *8*, 992-997. doi:10.2741/1171
- Crucian, G. P., Barrett, A. M., Burks, D. W., Riestra, A. R., Roth, H. L., Schwartz, R. L., et al. (2003). Mental object rotation in Parkinson's disease. *Journal of the International Neuropsychological Society*, *9*, 1078-1087. doi:10.1017/S1355617703970111
- Culbertson, W. C., Moberg, P. J., Duda, J. E., Stern, M. B., & Weintraub, D. (2004). Assessing the Executive Function Deficits of Patients with Parkinson's Disease. *Assessment*, *11*, 27-39. doi: 10.1177/1073191103258590
- Cummings, J. L., Darkins, A., Mendez, M., Hill, M. A., & Benson, D. F. (1988). Alzheimer's disease and Parkinson's disease: comparison of speech and language alterations. *Neurology*, *38*, 680-684. doi:10.1212/WNL.38.5.680
- Cunnington, R., Egan, G. F., O'Sullivan, J. D., Hughes, A. J., Bradshaw, J. L., & Colebatch, J. G. (2001). Motor imagery in Parkinson's disease: A PET study. *Movement Disorders*, *16*, 849-857. doi:10.1002/mds.1181
- Cunnington, R., Iansek, R., Thickbroom, G. W., Laing, B. A., Mastaglia, F. L., Bradshaw, J. L., et al. (1996). Effects of magnetic stimulation over supplementary motor area on movement in Parkinson's disease. *Brain*, *119*, 815-822. doi: 10.1093/brain/119.3.815
- Cunnington, R., Windischberger, C., & Moser, E. (2005). Premovement activity of the pre-supplementary motor area and the readiness for action: Studies of time-resolved event-related functional MRI. *Human Movement Science*, *24*, 644-656.  
doi:10.1016/j.humov.2005.10.001

- Cunnington, R., Windischberger, C., Deecke, L., & Moser, E. (2002). The Preparation and Execution of Self-Initiated and Externally-Triggered Movement: A Study of Event-Related fMRI. *NeuroImage*, *15*, 373-385. doi:10.1006/nimg.2001.0976
- Dassonville, P., Lewis, S. M., Zhu, X-H., Ugurbil, K., Kim, S-G., & Ashe, J. (1998). Effects of movement predictability on cortical motor activation. *Neuroscience Research*, *32*, 65-74. doi:10.1016/S0168-0102(98)00064-9
- De Caro, S., & Reeves, A. (2000). Rotating objects to determine orientation, not identity: Evidence from a backward-masking/dual-task procedure. *Attention, Perception, & Psychophysics*, *62*, 1356-1366. doi: 10.3758/BF03212138
- De Renzi, E., Faglioni, P., & Scotti, G. (1971). Judgment of spatial orientation in patients with focal brain damage. *Journal of Neurology, Neurosurgery and Psychiatry*, *34*, 489-495. doi:10.1136/jnnp.34.5.489
- De Renzi, E., Gentilini, M., & Barbieri, C. (1989). Auditory neglect. *Journal of Neurology, Neurosurgery and Psychiatry*, *52*, 613-617. doi:10.1136/jnnp.52.5.613
- Dechent, P., Merboldt, K-D., & Frahm, J. (2004). Is the human primary motor cortex involved in motor imagery? *Cognitive Brain Research*, *19*, 138-144. doi:10.1016/j.cogbrainres.2003.11.012
- Deecke, L., Grozinger, B., & Komhuber, H. H. (1976). Voluntary finger movement in man: Cerebral potentials and theory. *Biological Cybernetics*, *23*, 99-119. doi:10.1007/BF00336013
- Deiber, M. P., Ibanez, V., Sadato, N., & Hallett, M. (1996). Cerebral structures participating in motor preparation in humans: a positron emission tomography study. *Journal of Neurophysiology*, *75*, 233-247. Retrieved from: <http://www.nips.ac.jp/fmritms/pdf/1996/Deiber1996.pdf>



- Deiber, M. P., Passingham, R. E., Colebatch, J. G., Friston, K. J., Nixon, P. D., & Frackowiak, R. S. J. (1991). Cortical areas and the selection of movement: a study with positron emission tomography. *Experimental Brain Research*, *84*, 393-402.  
doi:10.1007/BF00231461
- Deiber, M-P., Honda, M., Ibanez, V., Sadato, N., & Hallett, M. (1999). Mesial Motor Areas in Self-Initiated Versus Externally Triggered Movements Examined With fMRI: Effect of Movement Type and Rate. *Journal of Neurophysiology*, *81*, 3065-3077. Retrieved from: <http://jn.physiology.org/content/81/6/3065.full.pdf>
- DeLong, M. R. & Wichmann, T. (2007). Circuits and circuit disorders of the basal ganglia, *Archives of Neurology*, *64*(1), 20-24. doi: 10.1001/archneur.64.1.20
- Dijkerman, H. C., Ietswaart, M., Johnston, M., & MacWalter, R. S. (2004). Does motor imagery training improve hand function in chronic stroke patients? A pilot study. *Clinical Rehabilitation*, *18*, 538-549. doi:10.1191/0269215504cr769oa
- Dominey, P., Decety, J., Broussolle, E., Chazot, G., Jeannerod, M. (1995). Motor imagery of a lateralized sequential task is asymmetrically slowed in hemi-Parkinson's patients. *Neuropsychologia*, *33*, 727-741. doi: 10.1016/0028-3932(95)00008-Q,
- Doyon, J., Owen, A. M., Petrides, M., Sziklas, V., & Evans, A. C. (1996). Functional Anatomy of Visuomotor Skill Learning in Human Subjects Examined with Positron Emission Tomography. *European Journal of Neuroscience*, *8*, 637-648. doi:10.1111/j.1460-9568.1996.tb01249.x
- Dubois, B., & Pillon, B. (1996). Cognitive deficits in Parkinson's disease. *Journal of Neurology*, *244*, 2-8. doi:10.1007/PL00007725
- Dum, R. P., & Strick, P. L. (1991). The origin of corticospinal projections from the premotor areas in the frontal lobe. *The Journal of Neuroscience*, *11*, 667-689.

- Duncombe, M. E., Bradshaw, J. L., Iansek, R., & Phillips, J. G. (1994). Parkinsonian patients without dementia or depression do not suffer from bradyphrenia as indexed by performance in mental rotation tasks with and without advance information. *Neuropsychologia*, *32*, 1383-1396. doi:10.1016/0028-3932(94)00071-9
- Ekstrom, R. B., French, J. W., Harman, H. H., & Dermen, D. (1976). *Manual for kit of factor-referenced cognitive tests*. Princeton: NJ7, Educational Testing Service.
- Elliott, R. (2003). Executive functions and their disorders: Imaging in clinical neuroscience. *British Medical Bulletin*, *65*(1), 49-59. doi: 10.1093/bmb/65.1.49
- Etard, O., Mellet, E., Papathanassiou, D., Benali, K., Houde, O., Mazoyer, B., et al. (2000). Picture naming without Broca's and Wernicke's area. *NeuroReport*, *11*, 617-622. doi:10.1097/00001756-200002280-00036
- Farah, M. J., Hammond, K. M., Levine, D. N., & Calvanio, R. (1988). Visual and spatial mental imagery: Dissociable systems of representation. *Cognitive Psychology*, *20*, 439-462. doi:10.1016/0010-0285(88)90012-6
- Farah, M. J., Wong, A. B., Monheit, M. A., & Morrow, L. A. (1989). Parietal lobe mechanisms of spatial attention: Modality-specific or supramodal? *Neuropsychologia*, *27*, 461-470. doi:10.1016/0028-3932(89)90051-1
- Farina, E., Cappa, S. F., Polimeni, M., Magni, E., Canesi, M., Zecchinelli, A., et al. (1994). Frontal dysfunction in early Parkinson's diseases. *Acta Neurologica Scandinavica*, *90*, 34-38. doi:10.1111/j.1600-0404.1994.tb02676.x
- Fimm, B., Zahn, R., Mull, M., Kemeny, S., Buchwald, F., Block, F., et al. (2001). Asymmetries of visual attention after circumscribed subcortical vascular lesions. *Journal of Neurology, Neurosurgery & Psychiatry*, *71*, 652-657. doi: 10.1136/jnnp.71.5.652

- Fink, G. R., Dolan, R. J., Halligan, P. W., Marshall, J. C., & Frith, C. D. (1997). Space-based and object-based visual attention: shared and specific neural domains. *Brain*, *120*, 2013-2028. doi: 10.1093/brain/120.11.2013
- Folstein, M. F., Folstein, S. E., & McHugh, P. R. (1975). "Mini-mental state" : A practical method for grading the cognitive state of patients for the clinician. *Journal of Psychiatric Research*, *12*, 189-198. doi:10.1016/0022-3956(75)90026-6
- Fournet, N., Moreaud, O., Roulin, J. L., Naegele, B., & Pellat, J. (2000). Working memory functioning in medicated Parkinson's disease patients and the effect of withdrawal of dopaminergic medication. *Neuropsychology*, *14*, 247-253. doi: 10.1037/0894-4105.14.2.247
- Fournet, N., Moreaud, O., Roulin, J. L., Naegele, B., & Pellat, J. (1996). Working memory in medicated patients with Parkinson's disease: the central executive seems to work. *J. Neurol. Neurosurg. Psychiat.*, *30*, 313-317. doi:10.1136/jnnp.60.3.313
- Fregni, F., Simon, D. K., Wu, A., & Pascual-Leone, A. (2005). Non-invasive brain stimulation for Parkinson's disease: a systematic review and meta-analysis of the literature. *Journal of Neurology, Neurosurgery & Psychiatry*, *76*, 1614-1623. doi:10.1136/jnnp.2005.069849
- Fujii, N., Mushiake, H., & Tanji, J. (2002). Distribution of Eye- and Arm-Movement-Related Neuronal Activity in the SEF and in the SMA and Pre-SMA of Monkeys. *Journal of Neurophysiology*, *87*, 2158-2166. doi: 10.1152/jn.00867.2001
- Fukuda, M., Mentis, M., Ghilardi, M. F., Dhawan, V., Antonini, A., Hammerstad, J., et al. (2001). Functional correlates of pallidal stimulation for Parkinson's disease. *Annals of Neurology*, *49*, 155-164. doi:10.1002/1531-8249(20010201)49:2<155::AID-ANA35>3.0.CO;2-9

- Gabrieli, J. D. E., Singh, J., Stebbins, G. T., & Goetz, C. G. (1996). Reduced working memory span in Parkinson's disease: Evidence for the role of a frontostriatal system in working and strategic memory. *Neuropsychology, 10*, 322–332. doi:10.1037/0894-4105.10.3.321
- Garavan, H., Ross, T. J., Kaufman, J., & Stein, E. A. (2003). A midline dissociation between error-processing and response-conflict monitoring. *NeuroImage, 20*, 1132-1139. doi:10.1016/S1053-8119(03)00334-3
- Gauthier, I., Hayward, W. G., Tarr, M. J., Anderson, A. W., Skudlarski, P., & Gore, J. C. (2002). BOLD Activity during Mental Rotation and Viewpoint-Dependent Object Recognition. *Neuron, 34*, 161-171. doi:10.1016/S0896-6273(02)00622-0
- Georgopoulos, A. P., Lurito, J. T., Petrides, M., Schwartz, A. B., & Massey, J. T. (1989) Mental rotation of the neuronal population vector. *Science, 243*:234-236
- Georgopoulos, A. P., & Pellizzer, G. (1995). The mental and the neural: Psychological and neural studies of mental rotation and memory scanning. *Neuropsychologia, 33*, 1531-1547. doi:10.1016/0028-3932(95)00079-I
- Georgopoulos, A. P., Schwartz, A. B., & Kettner, R. E. (1986) Neuronal population coding of movement direction. *Science, 233*, 1416–1419. doi: 10.1126/science.3749885
- Gerardin, E., Sirigu, A., Lehericy, S., Poline, J-B., Gaymard, B., Marsault, C., et al. (2000). Partially Overlapping Neural Networks for Real and Imagined Hand Movements. *Cerebral Cortex, 10*, 1093-1104. doi:10.1093/cercor/10.11.1093
- Glover, S., Wall, M. B., & Smith, A. T. (2012). Distinct cortical networks support the planning and online control of reaching-to-grasp in humans. *European Journal of Neuroscience, 35*, 909-915. doi:10.1111/j.1460-9568.2012.08018.x
- Goldberg, G. (1985). Supplementary motor area structure and function: review and hypotheses. *Behavioral and brain sciences, 8*, 567-616. doi:10.1017/S0140525X00045167

- Goldman, J. G., Weis, H., Stebbins, G., Bernard, B., & Goetz, C. G. Clinical differences among mild cognitive impairment subtypes in Parkinson's disease. *Movement Disorders*, 27, 1129-1136. doi: 10.1002/mds.25062
- Goodale, M. A., Milner, A. D., Jakobson, L. S., & Carey, D. P. (1991) A neurological dissociation between perceiving objects and grasping them. *Nature* 349, 154–6. doi:10.1038/349154a0
- Goodale, M. A., & Milner, A. D. (1992). Separate visual pathways for perception and action. *Trends in Neurosciences*, 15, 20-25. doi:10.1016/0166-2236(92)90344-8
- Goodale, M. A., Jakobson, L. S., & Keillor, J. M. (1994). Differences in the visual control of pantomimed and natural grasping movements. *Neuropsychologia*, 32, 1159-1178. doi:10.1016/0028-3932(94)90100-7
- Goodale, M. A., Meenan, J. P., Bulthoff, H. H., Nicolle, D. A., Murphy, K. J., & Racicot, C. I. (1994). Separate neural pathways for the visual analysis of object shape in perception and prehension. *Current Biology*, 4(7), 604-610. doi:10.1016/S0960-9822(00)00132-9
- Goodale, M. A., Wolf, M. E., Whitwell, R. L., Brown, L. E., Cant, J. S., Chapman, C. S., Witt, J. K., Arnott, S. R., Khan, S. A., Chouinard, P. A., Culham, J. C., & Dutton, G. N. (2008). Preserved motion processing and visuomotor control in a patient with larger bilateral lesions of occipitotemporal cortex. Talk given by the first author at the 8th Annual Meeting of the Vision Sciences Society, May 2008.
- Gould, N. F. K., Holmes, M. D., Fantie, B. A., Luckenbaugh, D. S., Pine, D. D., Gould, T., et al. (2007). Performance on a virtual reality spatial memory navigation task in depressed patients. *The American Journal of Psychiatry*, 164(3), 516-519. doi:10.1176/appi.ajp.164.3.516

- Grafton, S. T., Arbib, M. A., Fadiga, L., & Rizzolatti, G. (1996). Localization of grasp representations in humans by positron emission tomography. *Experimental Brain Research*, 112, 103-111. doi:10.1007/BF00227183
- Grafton, S. T., Fagg, A. H., & Arbib, M. A. (1998). Dorsal Premotor Cortex and Conditional Movement Selection: A PET Functional Mapping Study. *Journal of Neurophysiology*, 79(2), 1092-1097. <http://jn.physiology.org/content/79/2/1092.full.pdf>
- Grafton, S. T., Mazziotta, J. C., Presty, S., Friston, K. J., Frackowiak, R. S., & Phelps, M. E. (1992). Functional anatomy of human procedural learning determined with regional cerebral blood flow and PET. *The Journal of Neuroscience*, 12(7), 2542-2548. Retrieved from: <http://www.jneurosci.org/content/12/7/2542.full.pdf>
- Graham, J. M., & Sagar, H. J. (1999). A data-driven approach to the study of heterogeneity in idiopathic Parkinson's disease: identification of three distinct subtypes. *Movement Disorders*, 14, 10-20. doi:10.1002/1531-8257(199901)14:1<10::AID-MDS1005>3.0.CO;2-4
- Grezes, J., & Decety, J. (2002). Does visual perception of object afford action? Evidence from a neuroimaging study. *Neuropsychologia*, 40, 212-222. doi:10.1016/S0028-3932(01)00089-6
- Haller, S., Radue, E. W., Erb, M., Grodd, W., & Kircher, T. (2005). Overt sentence production in event-related fMRI. *Neuropsychologia*, 43, 807-814. doi:10.1016/j.neuropsychologia.2004.09.007
- Hamada, M., Ugawa, Y., & Tsuji, S. (2009). High-frequency rTMS over the supplementary motor area improves bradykinesia in Parkinson's disease: Subanalysis of double-blind sham-controlled study. *Journal of the Neurological Sciences*, 287, 143-146. doi:10.1177/1545968306292608

- Hamzei, F., Dettmers, C., Rzanny, R., Liepert, J., Buchel, C., & Weiller, C. (2002). Reduction of Excitability ("Inhibition") in the Ipsilateral Primary Motor Cortex Is Mirrored by fMRI Signal Decreases. *NeuroImage*, *17*, 490-496. doi:10.1006/nimg.2002.1077
- Hanakawa, T., Honda, M., Sawamoto, N., Okada, T., Yonekura, Y., Fukuyama, H., et al. (2002). The Role of Rostral Brodmann Area 6 in Mental-operation Tasks: an Integrative Neuroimaging Approach. *Cerebral Cortex*, *12*, 1157-1170. doi: 10.1093/cercor/12.11.1157
- Hanakawa, T., Immisch, I., Toma, K., Dimyan, M. A., Van Gelderen, P., & Hallett, M. (2003). Functional Properties of Brain Areas Associated With Motor Execution and Imagery. *Journal of Neurophysiology*, *89*, 989-1002. doi: 10.1152/jn.00132.2002
- Harnois, C., & Di Paolo, T. (1990). Decreased dopamine in the retinas of patients with Parkinson's disease. *Investigative Ophthalmology & Visual Science*, *31*, 2473-2475. Retrieved from: <http://www.iovs.org/content/31/11/2473.full.pdf>
- Harris, I. M., Egan, G. F., Sonkkila, C., Tochon-Danguy, H. J., Paxinos, G., & Watson, J. D. G. (2000). Selective right parietal lobe activation during mental rotation: A parametric PET study. *Brain*, *123*, 65-73. doi: 10.1093/brain/123.1.65
- Harris, I. M., Harris, J. A., & Caine, D. (2002). Mental-rotation deficits following damage to the right basal ganglia. *Neuropsychology*, *16*, 524-537. doi: 10.1037/0894-4105.16.4.524
- Haxby, J. V., Grady, C. L., Horwitz, B., Ungerleider, L. G., Mishkin, M., Carson, R. E., et al. (1991). Dissociation of object and spatial visual processing pathways in human extrastriate cortex. *Proceedings of the National Academy of Sciences*, *88*, 1621-1625. doi:10.1073/pnas.88.5.1621
- Haxby, J. V., Horwitz, B., Ungerleider, L. G., Maisog, J. M., Pietrini, P., & Grady, C. L. (1994). The functional organization of human extrastriate cortex: a PET-rCBF study of

- selective attention to faces and locations. *The Journal of Neuroscience*, 14, 6336-6353.
- Retrieved from: <http://haxbylab.dartmouth.edu/publications/HHU+94.pdf>
- Hayward, W. G., Zhou, G., Gauthier, I., & Harris, I. (2006). Dissociating viewpoint costs in mental rotation and object recognition. *Journal of Vision*, 6, 812. doi:10.1167/6.6.812
- Hazeltine, E., Grafton, S. T., & Ivry, R. (1997). Attention and stimulus characteristics determine the locus of motor-sequence encoding. A PET study. *Brain*, 120, 123-140. doi:10.1093/brain/120.1.123
- He, S. Q., Dum, R. P., & Strick, P. L. (1993). Topographic organization of corticospinal projections from the frontal lobe: motor areas on the lateral surface of the hemisphere. *The Journal of Neuroscience*, 13, 952-980.
- Heil, M., Rosler, F., Link, M., & Bajric, J. (1998). What is improved if a mental rotation task is repeated—The efficiency of memory access, or the speed of a transformation routine?. *Psychological Research*, 61, 99–106. doi:10.1007/s004260050016
- Heinze, H-J., Luck, S. J., Munte, T. F., Gos, A., Mangun, G. R., & Hillyard, S. A. (1994). Attention to adjacent and separate positions in space: An electrophysiological analysis. *Perception & Psychophysics*, 56(1), 42-52. doi:10.3758/BF03211689
- Henik, A., Singh, J., Beckley, D. J., & Rafal, R. D. (1993). Disinhibition of automatic word reading in Parkinson's disease. *Cortex: A Journal Devoted to the Study of the Nervous System and Behavior*, 29(4), 589-599.
- Hikosaka, O., Nakahara, H., R., M. K., Sakai, K., Lu, X., Nakamura, K., et al. (1999). Parallel neural networks for learning sequential procedures. *Trends in Neurosciences*, 22, 464-471. doi:10.1016/S0166-2236(99)01439-3
- Hikosaka, O., Nakamura, K., & Nakahara, H. (2006). Basal Ganglia Orient Eyes to Reward. *Journal of Neurophysiology*, 95, 567-584. doi: 10.1152/jn.00458.2005



- Hikosaka, O., Sakai, K., Miyauchi, S., Takino, R., Sasaki, Y., & Putz, B. (1996). Activation of human presupplementary motor area in learning of sequential procedures: a functional MRI study. *Journal of Neurophysiology*, *76*, 617-621. Retrieved from: <http://jn.physiology.org/content/76/1/617.full.pdf>
- Hikosaka, O., Takikawa, Y., & Kawagoe, R. (2000). Role of the Basal Ganglia in the Control of Purposive Saccadic Eye Movements. *Physiological Reviews*, *80*, 953-978. Retrieved from: <http://physrev.physiology.org/content/80/3/953.full.pdf>
- Himmelbach, M., & Karnath, H-O. (2005). Dorsal and Ventral Stream Interaction: Contributions from Optic Ataxia. *Journal of Cognitive Neuroscience*, *17*, 632-640. doi:10.1162/0898929053467514
- Hodgson, T. L., Tiesman, B., Owen, A. M., & Kennard, C. (2002). Abnormal gaze strategies during problem solving in Parkinson's disease. *Neuropsychologia*, *40*, 411-422. doi: 10.1016/S0028-3932(01)00099-9
- Hoehn, M. M., & Yahr, M. D. (1967). Parkinsonism. *Neurology*, *17*, 427. doi:10.1212/WNL.17.5.427
- Hoshi, E., & Tanji, J. (2004). Functional specialization in dorsal and ventral premotor areas *Progress in Brain Research* (Vol. 143, pp. 507-511): Elsevier. doi:10.1016/S0079-6123(03)43047-1
- Hovestadt, A., de Jong, G. J., & Meerwaldt, J. D. (1987). Spatial disorientation as an early symptom of Parkinson's disease. *Neurology*, *37*(3), 485. doi: 10.1212/WNL.37.3.485
- Humberstone, M., Sawle, G. V., Clare, S., Hykin, J., Coxon, R., Bowtell, R., et al. (1997). Functional magnetic resonance imaging of single motor events reveals human pre-supplementary motor area. *Annals of Neurology*, *42*, 632-637. doi:10.1002/ana.410420414

Iacoboni, M., Woods, R. P., & Mazziotta, J. C. (1998). Bimodal (auditory and visual) left frontoparietal circuitry for sensorimotor integration and sensorimotor learning.

*Brain*, 121, 2135-2143. doi:10.1093/brain/121.11.2135

Ikeda, A., Luders, H. O., Burgess, R. C., & Shibasaki, H. (1993). Movement-related potentials associated with single and repetitive movements recorded from human

supplementary motor area. *Electroencephalography and Clinical*

*Neurophysiology/Evoked Potentials Section*, 89, 269-277. doi:10.1016/0168-

5597(93)90106-Y

Ikeda, A., Lüders, H. O., Shibasaki, H., Collura, T. F., Burgess, R. C., Morris, H. H., &

Hamano, T. (1995). Movement-related potentials associated with bilateral

simultaneous and unilateral movements recorded from human supplementary

motor area, *Electroencephalography and Clinical Neurophysiology*, 95, 323-34.

doi:10.1016/0013-4694(95)00086-E

Ikeda, A., Yazawa, S., Kunieda, T., Ohara, S., Terada, K., Mikuni, N., et al. (1999). Cognitive motor control in human pre-supplementary motor area studied by subdural

recording of discrimination/selection-related potentials. *Brain*, 122, 915-931.

doi:10.1093/brain/122.5.915

Inase, M., Tokuno, H., Nambu, A., Akazawa, T., & Takada, M. (1999). Corticostriatal and

corticosubthalamic input zones from the pre-supplementary motor area in the

macaque monkey: comparison with the input zones from the supplementary motor

area. *Brain Research*, 833, 191-201. doi:10.1016/S0006-8993(99)01531-0

Isoda, M., & Tanji, J. (2004). Participation of the Primate Presupplementary Motor Area in

Sequencing Multiple Saccades. *Journal of Neurophysiology*, 92, 653-659. doi:

10.1152/jn.01201.2003

- Jahanshahi, M., Jenkins, I. H., Brown, R. G., Marsden, C. D., Passingham, R. E., & Brooks, D. J. (1995). Self-initiated versus externally triggered movements: I. An investigation using measurement of regional cerebral blood flow with PET and movement-related potentials in normal and Parkinson's disease subjects. *Brain*, *118*, 913-933. doi: 10.1093/brain/118.4.913
- James, T. W., Culham, J., Humphrey, G. K., Milner, A. D., & Goodale, M. A. (2003). Ventral occipital lesions impair object recognition but not object-directed grasping: an fMRI study. *Brain*, *126*, 2463-2475. doi: 10.1093/brain/awg248
- Jankovic, J. (2008). Parkinson's disease: clinical features and diagnosis. *Journal of Neurology, Neurosurgery & Psychiatry*, *79*, 368-376.
- Jeannerod, M. (1995). Mental imagery in the motor context. *Neuropsychologia*, *33*, 1419-1432. doi:10.1016/0028-3932(95)00073-C
- Jeannerod, M., & Frak, V. (1999). Mental imaging of motor activity in humans. *Current Opinion in Neurobiology*, *9*, 735-739. doi:10.1016/S0959-4388(99)00038-0
- Jenkins, I. H., Fernandez, W., Playford, E. D., Lees, A. J., Frackowiak, R. S. J., Passingham, R. E., & Brooks, D. J. (1992). Impaired activation of the supplementary motor area in Parkinson's disease is reversed when akinesia is treated with apomorphine. *Annals of Neurology*, *32*, 749-757. doi: 10.1002/ana.410320608
- Jenkins, I. H., Jahanshahi, M., Jueptner, M., Passingham, R. E., & Brooks, D. J. (2000). Self-initiated versus externally triggered movements: II. The effect of movement predictability on regional cerebral blood flow. *Brain*, *123*, 1216-1228. doi: 10.1093/brain/123.6.1216
- Johansen-Berg, H., Behrens, T. E. J., Robson, M. D., Drobnjak, I., Rushworth, M. F. S., Brady, J. M., et al. (2004). Changes in connectivity profiles define functionally distinct regions in human medial frontal cortex. *Proceedings of the National Academy of*

*Sciences of the United States of America*, 101, 13335-13340.

doi:10.1073/pnas.0403743101

Johansen-Berg, H., & Matthews, P. (2002). Attention to movement modulates activity in sensori-motor areas, including primary motor cortex. *Experimental Brain Research*, 142, 13-24. doi: 10.1007/s00221-001-0905-8

Johnston, S., Leek, E. C., Atherton, C., Thacker, N., & Jackson, A. (2004). Functional contribution of medial premotor cortex to visuo-spatial transformation in humans. *Neuroscience Letters*, 355, 209-212. doi:10.1016/j.neulet.2003.11.011

Jordan, K., Heinze, H. J., Lutz, K., Kanowski, M., & Jäncke, L. (2001). Cortical Activations during the Mental Rotation of Different Visual Objects. *NeuroImage*, 13, 143-152. doi:10.1006/nimg.2000.0677

Jueptner, M., Stephan, K. M., Frith, C. D., Brooks, D. J., Frackowiak, R. S. J., & Passingham, R. E. (1997). Anatomy of Motor Learning. I. Frontal Cortex and Attention to Action. *Journal of Neurophysiology*, 77, 1313-1324. Retrieved from: <http://jn.physiology.org/content/77/3/1313.full.pdf+html>

Karnath, H. O., Himmelbach, M., & Rorden, C. (2002). The subcortical anatomy of human spatial neglect: putamen, caudate nucleus and pulvinar. *Brain*, 125, 350-360. doi:10.1093/brain/awf032

Katzen, H. L., Levin, B. E., & Weiner, W. (2006). Side and type of motor symptom influence cognition in Parkinson's disease. *Movement Disorders*, 21, 1947-1953. doi:10.1002/mds.21105

Kehagia, A. A., Barker, R. A., & Robbins, T. W. (2010). Neuropsychological and clinical heterogeneity of cognitive impairment and dementia in patients with Parkinson's disease. *The Lancet Neurology*, 9, 1200-1213. doi: S147444221070212X

- Kemeny, S., Xu, J., Park, G. H., Hosey, L. A., Wettig, C. M., & Braun, A. R. (2006). Temporal Dissociation of Early Lexical Access and Articulation Using a Delayed Naming Task: An fMRI Study. *Cerebral Cortex*, *16*, 587-595. doi:10.1093/cercor/bhj006
- Kemps, E., Szmalec, A., Vandierendonck, A., & Crevits, L. (2005). Visuo-spatial processing in Parkinson's disease: evidence for diminished visuo-spatial sketch pad and central executive resources. *Parkinsonism & Related Disorders*, *11*, 181-186. doi:10.1016/j.parkreldis.2004.10.010
- Kempster, P. A., Gibb, W. R., Stern, G. M., & Lees, A. J. (1989). Asymmetry of substantia nigra neuronal loss in Parkinson's disease and its relevance to the mechanism of levodopa related motor fluctuations. *Journal of neurology, neurosurgery, and psychiatry*, *52*, 72-76. doi:10.1136/jnnp.52.1.72
- Kennerley, S. W., Sakai, K., & Rushworth, M. F. S. (2004). Organization of Action Sequences and the Role of the Pre-SMA. *Journal of Neurophysiology*, *91*(2), 978-993. doi:10.1152/jn.00651.2003
- Kerai, J. H., Bracewell, R. M., Hindle, J., & Leek, E. C. (in press). Visuo-spatial transformation impairments in Parkinson's disease. *Journal of Clinical and Experimental Neuropsychology*. doi:10.1080/13803395.2012.716396
- Kessels, R. P., Postma, A., Kappelle, L. J., & de Haan, E. H. (2000). Spatial memory impairment in patients after tumour resection: evidence for a double dissociation. *Journal of Neurology, Neurosurgery, and Psychiatry*, *69*, 389-391. doi:10.1136/jnnp.69.3.389
- Kitamura, J-I., Shibasaki, H., & Kondo, T. (1993). A cortical slow potential is larger before an isolated movement of a single finger than simultaneous movement of two fingers. *Electroencephalography and Clinical Neurophysiology*, *86*, 252-258. doi:10.1016/0013-4694(93)90106-6

- Kohler, S., Kapur, S., Moscovitch, M., Winocur, G., & Houle, S. (1995). Dissociation of pathways for object and spatial vision: a PET study in humans. *Neuroreport*, *6*, 1865-1868.
- Koriat, A., & Norman, J. (1984). What is rotated in mental rotation? *Journal of Experimental Psychology: Learning Memory and Cognition*, *10*, 421-434. doi:10.1037//0278-7393.10.3.421
- Kosslyn, S. M., Ball, T. M. & Reiser, B. J. (1978). Visual images preserve metric spatial information: Evidence from studies of image scanning. *Journal of Experimental Psychology: Human Perception and Performance*, *4*(1), 47-60. doi:10.1037//0096-1523.4.1.47
- Kosslyn, S. M., Digirolamo, G. J., Thompson, W. L., & Alpert, N. M. (1998). Mental rotation of objects versus hands: Neural mechanisms revealed by positron emission tomography. *Psychophysiology*, *35*, 151-161. doi:10.1111/1469-8986.3520151
- Kurata, K., Tsuji, T., Naraki, S., Seino, M., & Abe, Y. (2000). Activation of the Dorsal Premotor Cortex and Pre-Supplementary Motor Area of Humans during an Auditory Conditional Motor Task. *Journal of Neurophysiology*, *84*, 1667-1672.  
Retrieved from: <http://jn.physiology.org/content/84/3/1667.full.pdf>
- Lamm, C., Windischberger, C., Leodolter, U., Moser, E., & Bauer, H. (2001). Evidence for Premotor Cortex Activity during Dynamic Visuospatial Imagery from Single-Trial Functional Magnetic Resonance Imaging and Event-Related Slow Cortical Potentials. *NeuroImage*, *14*, 268-283. doi:10.1006/nimg.2001.0850
- Lang, W., Cheyne, D., Kristeva, R., Beisteiner, R., Lindinger, G., & Deecke, L. (1991). Three-dimensional localization of SMA activity preceding voluntary movement. *Experimental Brain Research*, *87*, 688-695. doi:10.1007/BF00227095

- Lang, W., Lang, M., Uhl, F., Koska, Ch, Kornhuber, A., & Deecke, L. (1988). Negative cortical DC shifts preceding and accompanying simultaneous and sequential finger movements. *Experimental Brain Research*, 71, 579-587. doi:10.1007/BF00248750
- Lange, K., Robbins, T., Marsden, C., James, M., Owen, A., & Paul, G. (1992). L-Dopa withdrawal in Parkinson's disease selectively impairs cognitive performance in tests sensitive to frontal lobe dysfunction. *Psychopharmacology*, 107, 394-404. doi: 10.1007/BF02245167
- Lassen, N. A., Ingvar, D. H., & Skinhøj, E. (1978) Brain function and blood flow. *Sci Am*. 239, 62-71. doi:10.1038/scientificamerican1078-62
- Lau, H. C., Rogers, R. D., Haggard, P., & Passingham, R. E. (2004). Attention to Intention. *Science*, 303, 1208-1210. doi: 10.1126/science.1090973
- Lee, A. C., Harris, J. P., & Calvert, J. E. (1998). Impairments of mental rotation in Parkinson's disease. *Neuropsychologia*, 36, 109-114. doi: 10.1016/S0028-3932(97)00017-1
- Lee, E-Y., Cowan, N., Vogel, E. K., Rolan, T., Valle-Inclan, F., & Hackley, S. A. (2010). Visual working memory deficits in patients with Parkinson's disease are due to both reduced storage capacity and impaired ability to filter out irrelevant information. *Brain*, 133, 2677-2689. doi: 10.1093/brain/awq197
- Lee, K-M., Chang, K-H., & Roh, J-K. (1999). Subregions within the Supplementary Motor Area Activated at Different Stages of Movement Preparation and Execution. *NeuroImage*, 9, 117-123. doi:10.1006/nimg.1998.0393
- Lee, S. S., Wild, K., Hollnagel, C. & Grafman, J. (1999) Selective visual attention in patients with frontal lobe lesions or Parkinson's disease. *Neuropsychologia* 37, 595-604. doi: 10.1016/S0028-3932(98)00081-5
- Leek, E. C., & Johnston, S. J. (2009). Functional specialization in the supplementary motor complex. *Nature Review Neuroscience*, 10, 78. doi:10.1038/nrn2478-c1

- Lehéricy, S., Ducros, M., Van De Moortele, P-F., Francois, C., Thivard, L., Poupon, C., et al. (2004). Diffusion tensor fiber tracking shows distinct corticostriatal circuits in humans. *Annals of Neurology*, 55(4), 522-529. doi: 10.1002/ana.20030
- Leplow, B., Holl, D., Zeng, L., Herzog, A., Behrens, K., & Mehdorn, M. (2002). Spatial behaviour is driven by proximal cues even in mildly impaired Parkinson's disease. *Neuropsychologia*, 40, 1443-1455. doi:10.1016/S0028-3932(01)00205-6
- Levin, B. E., Llabre, M. M., Reisman, S., Weiner, W. J., Sanchez-Ramos, J. , Singer, C., et al. (1991). Visuospatial impairment in Parkinson's disease. *Neurology*, 41, 365-369. doi: 10.1212/WNL.41.3.365
- Lewis, S. J. G., Foltynie, T., Blackwell, A. D., Robbins, T. W., Owen, A. M., & Barker, R. A. (2005). Heterogeneity of Parkinson's disease in the early clinical stages using a data driven approach. *Journal of Neurology, Neurosurgery & Psychiatry*, 76, 343-348. doi:10.1136/jnnp.2003.033530
- Lezak, M. D. (1982). The problem of assessing executive functions. *International Journal of Psychology*, 17, 281-297.
- Linn, M. C., & Petersen, A. C. (1985). Emergence and Characterization of Sex Differences in Spatial Ability: A Meta-Analysis. *Child Development*, 56, 1479-1498. doi:10.1111/j.1467-8624.1985.tb00213.x
- Liu, K. P. Y., Chan, C. C. H., Lee, T. M. C., & Hui-Chan, C. W. Y. (2004). Mental imagery for relearning of people after brain injury. *Brain Injury*, 18, 1163-1172. doi:10.1080/02699050410001671883
- Livingstone, M., & Hubel, D. (1988). Segregation of form, color, movement, and depth: anatomy, physiology, and perception. *Science*, 6, 740-749. Retrieved from: <http://www.sciencemag.org/content/240/4853/740.long>



- Logie, R. H., & Marchetti, C. (1991). *Visuo-spatial working memory: Visual, spatial or central executive? Advances in Psychology* (Vol. 80, pp. 105-115): North-Holland
- Logie, R. H., Zucco, G. M., & Baddeley, A. D. (1990). Interference with visual short-term memory. *Acta Psychologica*, 75, 55-74. doi:10.1016/0001-6918(90)90066-O
- Lu, M-T., Preston, J. B., & Strick, P. L. (1994). Interconnections between the prefrontal cortex and the premotor areas in the frontal lobe. *The Journal of Comparative Neurology*, 341, 375-392. doi:10.1002/cne.903410308
- Luppino, G., Matelli, M., Camarda, R. M., & Rizzolatti, G. (1993). Corticocortical connections of area F3 (SMA-proper) and area F6 (pre-SMA) in the macaque monkey. *The Journal of Comparative Neurology*, 338, 114-140. doi:10.1002/cne.903380109
- Luppino, G., Matelli, M., Camarda, R. M., Gallese, V., & Rizzolatti, G. (1991). Multiple representations of body movements in mesial area 6 and the adjacent cingulate cortex: An intracortical microstimulation study in the macaque monkey. *The Journal of Comparative Neurology*, 311, 463-482. doi:10.1002/cne.903110403
- Luppino, G., Rozzi, S., Calzavara, R., & Matelli, M. (2003). Prefrontal and agranular cingulate projections to the dorsal premotor areas F2 and F7 in the macaque monkey. *European Journal of Neuroscience*, 17, 559-578. doi:10.1046/j.1460-9568.2003.02476.x
- Luque-Moreno, C., Lopez-Garcia, J. C., & Diaz-Argandoña, E. (2012). Analysis of sustained attention in Parkinsonian patients treated with dopamine precursors. *Journal of Neurology*, 55, 257-262.
- Maddox, W. T., Filoteo, J. V., Delis, D. C. & Salmon, D. P. 1996
- Maier, M. A., Armand, J., Kirkwood, P. A., Yang, H. W., Davis, J. N., & Lemon, R. N. (2002). Differences in the Corticospinal Projection from Primary Motor Cortex and Supplementary Motor Area to Macaque Upper Limb Motoneurons: An Anatomical

- and Electrophysiological Study. *Cerebral Cortex*, *12*, 281-296  
doi:10.1093/cercor/12.3.281
- Malouin, F., Richards, C. L., Doyon, J., Desrosiers, J., & Belleville, S. (2004). Training Mobility Tasks after Stroke with Combined Mental and Physical Practice: A Feasibility Study. *Neurorehabilitation and Neural Repair*, *18*, 66-75. doi:10.1177/0888439004266304
- Malouin, F., Richards, C. L., Jackson, P. L., Dumas, F., & Doyon, J. (2003). Brain activations during motor imagery of locomotor-related tasks: A PET study. *Human Brain Mapping*, *19*, 47-62. doi:10.1002/hbm.10103
- Marras, C., & Lang, A. (in press). Parkinson's disease subtypes: lost in translation? *Journal of Neurology, Neurosurgery & Psychiatry*.
- Matsuzaka, Y., & Tanji, J. (1996). Changing directions of forthcoming arm movements: neuronal activity in the presupplementary and supplementary motor area of monkey cerebral cortex. *Journal of Neurophysiology*, *76*, 2327-2342. Retrieved from: <http://jn.physiology.org/content/76/4/2327.full.pdf>
- Matsuzaka, Y., Aizawa, H., & Tanji, J. (1992). A motor area rostral to the supplementary motor area (pre-supplementary motor area) in the monkey: neuronal activity during a learned motor task. *Journal of Neurophysiology*, *68*, 653-662. Retrieved from: <http://jn.physiology.org/content/68/3/653.full.pdf>
- McCloskey, M. (2001). Spatial representation in mind and brain. In B. Rapp (Ed.), *What deficits reveal about the human mind/brain: A handbook of cognitive neuropsychology* (pp. 101-132). Philadelphia, PA: Psychology Press.
- McCloskey, M. (2009). *Visual Reflections: A perceptual deficit and its implications*. Oxford Psychology Press, Oxford.

- McCloskey, M., & Rapp, B. (2000). Attention-referenced visual representations: Evidence from impaired visual localization. *Journal of Experimental Psychology: Human Perception and Performance*, *26*, 917-933. doi: 10.1037//0096-1523.26.3.917. 2000
- McCloskey, M., Rapp, B., Yantis, S., Rubin, G., Bacon, W. F., Dagnelie, G., et al. (1995). A Developmental Deficit in Localizing Objects from Vision. *Psychological Science*, *6*, 112-117. doi:10.1111/j.1467-9280.1995.tb00316.x
- McCloskey, M., Valtonen, J., & Sherman, J. (2006). Representing orientation: A coordinate-system hypothesis, and evidence from developmental deficits. *Cognitive Neuropsychology*, *23*, 680-713. doi:10.1234/12345678
- McGee, M. G. (1979). Human Spatial Abilities: Psychometric Studies and Environmental, Genetic, Hormonal, and Neurological Influences. *Psychological Bulletin*, *86*, 889-918. doi:10.1037//0033-2909.86.5.889
- McKinlay, A., Kaller, C. P., Grace, R. C., Dalrymple-Alford, J. C., Anderson, T. J., Fink, J., et al. (2008). Planning in Parkinson's disease: A matter of problem structure? *Neuropsychologia*, *46*, 384-389. doi:10.1016/j.neuropsychologia.2007.08.018
- Middleton, F. A., & Strick, P. L. (2000). Basal Ganglia Output and Cognition: Evidence from Anatomical, Behavioral, and Clinical Studies. *Brain and Cognition*, *42*, 183-200. doi:10.1006/brcg.1999.1099
- Milivojevic, B., Hamm, J. P., & Corballis, M. C. (2009). Functional Neuroanatomy of Mental Rotation. *Journal of Cognitive Neuroscience*, *21*, 945-959. doi:10.1162/jocn.2009.21085
- Milner, A. D., Dijkerman, H. C., & Carey, D. P. (1999) Visuospatial processing in a pure case of visual from agnosia. In: Burgess, N., JeVrey K. J., O'Keefe, J. (eds) *The hippocampal and parietal functions of spatial cognition*. Oxford University Press, Oxford, pp 443-466.

Milner, A. D., Dijkerman, H. C., McIntosh, R. D., Rossetti, Y., Pisella, L., Prablanc, C.,

Pelisson, D., & Rossetti, Y. (2003). *Delayed reaching and grasping in patients with optic ataxia* *Progress in Brain Research* (Vol. Volume 142, pp. 225-242): Elsevier.

doi:10.1016/S0079-6123(03)42016-5

Milner, A. D., Perrett, D. I., Johnston, R. S., Benson, P. J., Jordan, T. R., Heeley, D. W., et al.

(1991). Perception and action in "visual form agnosia". *Brain*, *114*, 405-428.

doi:10.1093/brain/114.1.405

Mink, J. W. (1996). The basal ganglia: focused selection and inhibition of competing motor

programs. *Progress in Neurobiology*, *50*, 381-425. doi:10.1016/S0301-0082(96)00042-1

Miyachi, S., Hikosaka, O., Miyashita, K., Kárádi, Z., & Rand, M. K. (1997). Differential roles

of monkey striatum in learning of sequential hand movement. *Experimental Brain*

*Research*, *115*, 1-5. doi:10.1007/PL00005669

Montse, A., Pere, V., Carme, J., Francesc, V., & Eduardo, T. (2001). Visuospatial Deficits in

Parkinsons Disease Assessed by Judgment of Line Orientation Test: Error Analyses and Practice Effects. *Journal of Clinical and Experimental Neuropsychology*, *23*, 592-598.

doi: 10.1076/jcen.23.5.592.1248

Morris, M. E., Iansek, R., Matyas, T. A., & Summers, J. J. (1996). Stride length regulation in

Parkinson's disease: Normalization strategies and underlying mechanisms. *Brain*,

*119*, 551-568. doi: 10.1093/brain/119.2.551

Mushiake, H., Inase, M., & Tanji, J. (1991). Neuronal activity in the primate premotor,

supplementary, and precentral motor cortex during visually guided and internally determined sequential movements. *Journal of Neurophysiology*. *66*, 705-718.

Retrieved from: <http://web.mit.edu/gorlins/Public/Motor%20System/Mushiake.pdf>

- Nachev, P., Kennard, C., & Husain, M. (2008). Functional role of the supplementary and pre-supplementary motor areas. *Nature Reviews Neuroscience*, *9*, 856-869.  
doi:10.1038/nrn2478
- Nachev, P., Rees, G., Parton, A., Kennard, C., & Husain, M. (2005). Volition and Conflict in Human Medial Frontal Cortex. *Current Biology*, *15*, 122-128. doi:  
10.1016/j.cub.2005.01.006.
- Nachev, P., Wydell, H., O'Neill, K., Husain, M., & Kennard, C. (2007). The role of the pre-supplementary motor area in the control of action. *NeuroImage*, *36*, 155-163.  
doi:10.1002/hbm.10126
- Nakamura, K., & Hikosaka, O. (2006). Role of Dopamine in the Primate Caudate Nucleus in Reward Modulation of Saccades. *The Journal of Neuroscience*, *26*, 5360-5369.  
doi:10.1523/JNEUROSCI.4853-05.2006
- Nakamura, K., Sakai, K., & Hikosaka, O. (1998). Neuronal activity in medial frontal cortex during learning of sequential procedures. *Journal of Neurophysiology*, *80*, 2671-2687.  
Retrieved from: <http://jn.physiology.org/content/80/5/2671.full.pdf>
- Nakamura, K., Sakai, K., & Hikosaka, O. (1999). Effects of Local Inactivation of Monkey Medial Frontal Cortex in Learning of Sequential Procedures. *Journal of Neurophysiology*, *82*, 1063-1068. Retrieved from:  
<http://jn.physiology.org/content/82/2/1063.full.pdf>
- Nambu, A., Takada, M., Inase, M., & Tokuno, H. (1996). Dual somatotopical representations in the primate subthalamic nucleus: evidence for ordered but reversed body-map transformations from the primary motor cortex and the supplementary motor area. *Journal of Neuroscience*, *16*, 2671-2683.
- Newcombe, F., Ratcliff, G., & Damasio, H. (1987). Dissociable visual and spatial impairments following right posterior cerebral lesions: Clinical, neuropsychological and

anatomical evidence. *Neuropsychologia*, 25, 149-161. doi:10.1016/0028-3932(87)90127-

8

Nguyen-Legros, J., Harnois, C., Di Paolo, T., Simon, A. (1993). The retinal dopamine system

in Parkinson's disease. *Clin Vis Set*, 8, 1-12.

Niemeier, J. P., Cifu, D. X., & Kishore, R. (2001). The lighthouse strategy: Improving the

functional status of patients with unilateral neglect after stroke and brain injury

using a visual imagery intervention. *Topics in Stroke Rehabilitation*, 8(2), 10-18.

Ogden, J. A., Growdon, J. H., & Corkin, S. (1990). Deficits on visuospatial tests involving

forward planning in high-functioning Parkinsonians. *Neuropsychiatry*,

*Neuropsychology*, & *Behavioral Neurology*, 3, 125-139. Retrieved from:

[http://web.mit.edu/bnl/pdf/Ogden\\_Growdon\\_Corkin\\_1990.pdf](http://web.mit.edu/bnl/pdf/Ogden_Growdon_Corkin_1990.pdf)

Okiyama, R., & Shimizu, N. (1993). Saccadic eye movement related scalp potentials-scalp

distribution of presaccadic slow negative potential. *Clinical neurology*, 33, 483-490.

Olanow, C. W. & Tatton, W. G. (1999). Etiology and pathogenesis of Parkinson's disease.

*Annual Review of Neuroscience*, 22(1), 123-144. doi:10.1146/annurev.neuro.22.1.123

Orgogozo J. M., Larsen, B., Roland, P. E., Lassen, N. A. (1979) Activation de l'aire motrice

supplemental au cours des mouvements volontaires chez l'homme. *Rev Neurol*

(Paris), 135, 705-717.

Orgogozo, J. M., & Larsen, B. (1979). Activation of the supplementary motor area during

voluntary movement in man suggests it works as a supramotor area. *Science*, 206,

847-850. doi:10.1126/science.493986

Osborn, J. R., Agogino, A. M. (1992). An interface for interactive spatial

reasoning and visualization. *Proc. Chi*, 75-82.

- Owen, A. M. (2004). Cognitive Dysfunction in Parkinson's Disease: The Role of Frontostriatal Circuitry. *The Neuroscientist*, 10(6), 525-537.  
doi:10.1177/1073858404266776
- Owen, A. M., Iddon, J. L., Hodges, J. R., Summers, B. A., & Robbins, T. W. (1997). Spatial and non-spatial working memory at different stages of Parkinson's disease. *Neuropsychologia*, 35, 519-532. doi:10.1016/S0028-3932(96)00101-7
- Page, S. J., Levine, P., & Leonard, A. C. (2005). Effects of mental practice on affected limb use and function in chronic stroke. *Archives of Physical Medicine and Rehabilitation*, 86, 399-402. doi:10.1016/j.apmr.2004.10.002
- Page, S. J., Levine, P., Sisto, S. A., & Johnston, M. V. (2001). Mental Practice Combined With Physical Practice for Upper-Limb Motor Deficit in Subacute Stroke. *Physical Therapy*, 81, 1455-1462. Retrieved from:  
<http://physicaltherapyjournal.com/content/81/8/1455.full.pdf>
- Papa, S. M., Artieda, J., & Obeso, J. A. (1991). Cortical activity preceding self-initiated and externally triggered voluntary movement. *Movement Disorders*, 6, 217-224. doi:10.1002/mds.870060305
- Parr, W. V. (1992). Delayed matching-to-sample performance as a measure of human visuospatial working memory. *Bulletin of the Psychonomic Society*, 30, 369-372.
- Parsons, L. M. (1987). Imagined spatial transformations of one's hands and feet. *Cognitive Psychology*, 19, 178-241. doi:10.1016/0010-0285(87)90011-9
- Parsons, L. M. (1994). Temporal and kinematic properties of motor behavior reflected in mentally simulated action. *Journal of Experimental Psychology: Human Perception and Performance*, 20, 709-730. doi:10.1037//0096-1523.20.4.709

- Parsons, L. M., Fox, P. T., Downs, J. H., Glass, T., Hirsch, T. B., Martin, C. C., Jerabek, P. A., and Lancaster, J. L. (1995). Use of implicit motor imagery for visual shape discrimination as revealed by PET. *Nature*, *375*: 54–58. doi:10.1038/375054a0
- Parthasarathy, H. B., Schall, J. D., & Graybiel, A. M. (1992). Distributed but convergent ordering of corticostriatal projections: analysis of the frontal eye field and the supplementary eye field in the macaque monkey. *Journal of Neuroscience*, *12*, 4468-4488. Retrieved from: <http://www.jneurosci.org/content/12/11/4468.long>
- Passingham, R. E. (1993) *The frontal lobes and voluntary action*, Oxford University Press, Oxford.
- Passingham, R. E. (1996). *Attention to action*. [Article]. *Philosophical Transactions of the Royal Society of London Series B-Biological Sciences*, *351*, 1473-1479. doi:10.1098/rstb.1996.0132
- Pellizzer, G., & Georgopoulos, A. P. (1993). Common processing constraints for visuomotor and visual mental rotations. *Experimental Brain Research*, *93*, 165-172. doi: 10.1007/BF00227791
- Petit, L., Courtney, S. M., Ungerleider, L. G., & Haxby, J. V. (1998). Sustained Activity in the Medial Wall during Working Memory Delays. *Journal of Neuroscience*, *18*, 9429-9437. doi: 0270-6474/98/189429-09
- Petrides, M. (1985). Deficits in non-spatial conditional associative learning after periaruate lesions in the monkey. *Behavioural Brain Research*, *16*, 95-101. doi: 10.1016/0166-4328(85)90085-3
- Picard, N., & Strick, P. L. (1996). Motor Areas of the Medial Wall: A Review of Their Location and Functional Activation. *Cerebral Cortex*, *6*, 342-353. doi:10.1093/cercor/6.3.342



- Picard, N., & Strick, P. L. (2001). Imaging the premotor areas. *Current Opinion in Neurobiology*, 11, 663-672. doi:10.1016/S0959-4388(01)00266-5
- Picard, N., & Strick, P. L. (2003). Activation of the Supplementary Motor Area (SMA) during Performance of Visually Guided Movements. *Cerebral Cortex*, 13, 977-986. doi:10.1093/cercor/13.9.977
- Pillon, B., Deweer, B., Vidailhet, M., Bonnet, A-M., Hahn-Barma, V., & Dubois, B. (1998). Is impaired memory for spatial location in Parkinson's disease domain specific or dependent on 'strategic' processes? *Neuropsychologia*, 36, 1-9. doi:10.1016/S0028-3932(97)00102-4
- Pillon, B., Dubois, B., Bonnet, A. M., Esteguy, M., Guimaraes, J., Vigouret, J. M., et al. (1989). Cognitive slowing in Parkinson's disease fails to respond to levodopa treatment. *Neurology*, 39, 762. doi: 10.1212/WNL.39.6.762
- Pillon, B., Dubois, B., Ploska, A., & Agid, Y. (1991). Severity and specificity of cognitive impairment in Alzheimer's, Huntington's, and Parkinson's diseases and progressive supranuclear palsy. *Neurology*, 41, 634-643. doi:10.1212/WNL.41.5.634
- Pillon, B., Ertle, S., Deweer, B., Sarazin, M., Agid, Y., & Dubois, B. (1996). Memory for spatial location is affected in Parkinson's disease. *Neuropsychologia*, 34, 77-85. doi:10.1016/0028-3932(95)00086-0
- Playford, E. D., Jenkins, I. H., Passingham, R. E., Nutt, J., Frackowiak, R.S., Brooks, D.J. (1992). Impaired mesial frontal and putamen activation in Parkinson's disease: a positron emission tomography study. *Annals of Neurology*, 32, 151-161. <http://dx.doi.org/10.1002/ana.410320206>
- Possin, K. L., Filoteo, J. V., Song, D. D. & Salmon, D. P. (2008). Spatial and object working memory deficits in Parkinson's disease are due to impairment in different underlying processes. *Neuropsychology*, 22(5), 585-95. doi: 10.1037/a0012613

- Postle, B. R., & D'Esposito, M. (1999). "What"-Then-Where" in visual working memory: an event-related fMRI study. *Journal of Cognitive Neuroscience*, *11*, 585-597.
- Press, D. Z., Casement, M. D., Pascual-Leone, A., Robertson, E. M. (2005) The time course of off-line motor sequence learning. *Brain Res Cogn Brain Res*, *25*(1):375-8.
- Price, A. L. (2006). Explicit category learning in Parkinson's disease: Deficits related to impaired rule generation and selection processes. *Neuropsychology*, *20*, 249-257.  
doi:10.1037/0894-4105.20.2.249
- Rascol, O., Sabatini, U., Chollet, F., Fabre, N., Senard, J. M., Montastruc, J. L., et al. (1994). Normal activation of the supplementary motor area in patients with Parkinson's disease undergoing long-term treatment with levodopa. *Journal of Neurology, Neurosurgery, and Psychiatry*, *57*, 567-571. doi:10.1136/jnnp.57.5.567
- Raskin, S. A., Tweedy, J. R., & Borod, J. C. (1990 ). Effect of inversion on memory for faces in Parkinson's disease and right-hemisphere stroke patients. *Journal of Communication Disorders*, *23*, 303-323. doi:10.1016/0021-9924(90)90006-K
- Revonsuo, A., Portin, R., Koivikko, L., Rinne, J. O., & Rinne, U. K. (1993). Slowing of Information Processing in Parkinson's Disease. *Brain and Cognition*, *21*, 87-110.  
doi:10.1006/brcg.1993.1007
- Rey, A. 1941. Psychological examination of traumatic encephalopathy. *Archives de Psychologie*, *28*, 286-340.
- Rice, N. J., Edwards, M. G., Schindler, I., Punt, T. D., McIntosh, R. D., Humphreys, G. W., et al. (2008). Delay abolishes the obstacle avoidance deficit in unilateral optic ataxia. *Neuropsychologia*, *46*, 1549-1557. doi:10.1016/j.neuropsychologia.2008.01.012
- Rice, N., McIntosh, R., Schindler, I., Mon-Williams, M., Démonet, J-F., & Milner, A. (2006). Intact automatic avoidance of obstacles in patients with visual form agnosia. *Experimental Brain Research*, *174*, 176-188. doi:10.1007/s00221-006-0435-5

- Richter, W., Somorjai, R., Summers, R., Jarmasz, M., Menon, R. S., Gati, J. S., et al. (2000). Motor Area Activity During Mental Rotation Studied by Time-Resolved Single-Trial fMRI. *Journal of Cognitive Neuroscience*, *12*, 310-320. doi:10.1162/089892900562129
- Richter, W., Ugurbil, K., Georgopoulos, A. P., & Kim, S-G. (1997). Time-resolved fMRI of mental rotation. *NeuroReport*, *8*, 3697-3702. doi:10.1097/00001756-199712010-00008
- Rizzo, A. A., Buckwalter, J. G., McGee, J. S., Bowerly, T., Zaag, C., Neumann, U., et al. (2001). Virtual Environments for Assessing and Rehabilitating Cognitive/Functional Performance A Review of Projects at the USC Integrated Media Systems Center. Presence: *Teleoperators and Virtual Environments*, *10*, 359-374. doi:10.1162/1054746011470226
- Rizzolatti, G., Gentilucci, M., Camarda, R. M., Gallese, V., Luppino, G., Matelli, M., et al. (1990). Neurons related to reaching-grasping arm movements in the rostral part of area 6 (area 6a beta). *Experimental brain research*, *82*, 337-350. doi:10.1007/BF00231253
- Rogers, D., Lees, A. J., Smith, E., Trimble, M., & Stern, G. M. (1987). Bradyphrenia in Parkinson's disease and psychomotor retardation in depressive illness. *Brain*, *110*, 761-776. doi:10.1093/brain/110.3.761
- Roland, P. E., Larsen, B., Lassen, N. A., & Skinhøj, E. (1980). Supplementary motor area and other cortical areas in organization of voluntary movements in man. *Journal of Neurophysiology*, *43*, 118-136. Retrieved from: <http://jn.physiology.org/content/43/1/118.full.pdf>
- Romanski, L. M., Tian, B., Fritz, J., Mishkin, M., Goldman-Rakic, P. S., & Rauschecker, J. P. (1999). Dual streams of auditory afferents target multiple domains in the primate prefrontal cortex. *Nature Neuroscience*, *2*, 1131-1136. doi:10.1038/16056

Roth, M., Decety, J., Raybaudi, M., Massarelli, R., Delon-Martin, C., Segebarth, C., et al.

(1996). Possible involvement of primary motor cortex in mentally simulated movement: a functional magnetic resonance imaging study. *Neuroreport*, 7, 1280-1284. doi:10.1097/00001756-199605170-00012

Rowe, J. B., & Passingham, R. E. (2001). Working Memory for Location and Time: Activity in

Prefrontal Area 46 Relates to Selection Rather than Maintenance in Memory. *NeuroImage*, 14, 77-86. doi:10.1006/nimg.2001.0784

Rushworth, M. F. S., Hadland, K. A., Paus, T., & Sipila, P. K. (2002). Role of the Human

Medial Frontal Cortex in Task Switching: A Combined fMRI and TMS Study. *Journal of Neurophysiology*, 87, 2577-2592. doi: 10.1152/jn.00812.2001.

Rushworth, M. F. S., Krams, M., & Passingham, R. E. (2001). The Attentional Role of the Left

Parietal Cortex: The Distinct Lateralization and Localization of Motor Attention in the Human Brain. *Journal of Cognitive Neuroscience*, 13, 698-710. doi:

10.1162/089892901750363244

Sabatini, U., Boulanouar, K., Fabre, N., Martin, F., Carel, C., Colonnese, C., et al. (2000).

Cortical motor reorganization in akinetic patients with Parkinson's disease. *Brain*, 123, 394-403. doi:10.1093/brain/123.2.394

Sakai, K., Hikosaka, O., Miyauchi, S., Sasaki, Y., Fujimaki, N., & Putz, B. (1999). Pre-

supplementary Motor Area Activation during Sequence Learning Reflects Visuo-Motor Association. *The Journal of Neuroscience*, 19, RC1. Retrieved from:

<http://www.jneurosci.org/content/19/10/RC1.full.pdf>

Sakai, S. T., Stepniewska, I., Qi, H. X., & Kaas, J. H. (2000). Pallidal and cerebellar afferents to

pre-supplementary motor area thalamocortical neurons in the owl monkey: A multiple labelling study. *The Journal of Comparative Neurology*, 417, 164-180.

doi:10.1002/(SICI)1096-9861(20000207)417:2<164::AID-CNE3>3.0.CO;2-6

- Sakata, H., Taira, M., Murata, A., & Mine, S. (1995). Neural mechanisms of visual guidance of hand action in the parietal cortex of the monkey, *Cerebral Cortex*, 5, 429–438.  
doi: 10.1093/cercor/5.5.429
- Salmi, J., Rinne, T., Degerman, A., Salonen, O., & Alho, K. (2007). Orienting and maintenance of spatial attention in audition and vision: multimodal and modality-specific brain activations. *Brain Structure and Function*, 212, 181-194. doi:10.1007/s00429-007-0152-2
- Sammer, G., Reuter, I., Hullmann, K., Kaps, M., & Vaitl, D. (2006). Training of executive functions in Parkinson's disease. *Journal of the Neurological Sciences*, 248(2), 115-119.  
doi:10.1016/j.jns.2006.05.028
- Sampaio, J., Bobrowicz-Campos, E., André, R., Almeida, I., Faria, P., Januário, C., et al. (2010). Specific impairment of visual spatial covert attention mechanisms in Parkinson's disease. *Neuropsychologia*, 49, 34-42.  
doi:10.1016/j.neuropsychologia.2010.11.002
- Sawamoto, N., Honda, M., Hanakawa, T., Fukuyama, H., & Shibasaki, H. (2002). Cognitive slowing in Parkinson's disease: a behavioral evaluation independent of motor slowing. *J Neuroscience*, 22, 5198-5203. doi: 0270-6474/02/225198-06
- Schindler, I., Rice, N., McIntosh, R. D., Rossetti, Y., Vighetto, A., & Milner, A. D. (2004). Automatic avoidance of obstacles is a dorsal stream function: Evidence from optic ataxia. *Nature Neuroscience*, 7, 779-784. doi:10.1038/nn1273
- Schrag, A., Quinn, N. P., & Ben-Shlomo, Y. (2006). Heterogeneity of Parkinson's disease. *Journal of Neurology, Neurosurgery & Psychiatry*, 77, 275-276. Retrieved from:  
<http://jnnp.bmj.com/content/77/2/275.full.pdf>
- Seitz, R. J., & Roland, P. E. (1992) Vibratory stimulation increases and decreases the regional cerebral blood flow and oxidative metabolism: a positron emission tomography (PET) study. *Acta Neurol Scand*, 86, 60–7. doi:10.1111/j.1600-0404.1992.tb08055.x

- Semmes, J., Weinstein, S., Ghent, G., Meyer, J. S., & Teuber, H-L. (1963). Correlates of impaired orientation in personal and extrapersonal space. *Brain*, 86, 747-772.  
doi:10.1093/brain/86.4.747
- Shallice, T. (1982). Specific Impairments of Planning. *Philosophical Transactions of the Royal Society of London. B, Biological Sciences*, 298(1089), 199-209.  
doi:10.1098/rstb.1982.0082
- Shepard, R.N., & Cooper, L.A. (1982). *Mental images and their transformations*. Cambridge, MA: MIT Press.
- Shepard, R. N., & Metzler, J. (1971). Mental Rotation of Three-Dimensional Objects. *Science*, 171(3972), 701-703. doi:10.1126/science.171.3972.701
- Shima, K., & Tanji, J. (1998). Both Supplementary and Pre-supplementary Motor Areas Are Crucial for the Temporal Organization of Multiple Movements. *Journal of Neurophysiology*, 80, 3247-3260. Retrieved from:  
<http://jn.physiology.org/content/80/6/3247.full.pdf>
- Shima, K., & Tanji, J. (2000). Neuronal activity in the supplementary and pre-supplementary motor areas for temporal organization of multiple movements. *Journal of Neurophysiology*, 84, 2148-2160. Retrieved from:  
<http://jn.physiology.org/content/84/4/2148.full.pdf+html>
- Shima, K., Mushiake, H., Saito, N., & Tanji, J. (1996). Role for cells in the pre-supplementary motor area in updating motor plans. *Proceedings of the National Academy of Sciences of the United States of America*, 93, 8694-8698. doi:10.1073/pnas.93.16.8694
- Simonetta, M., Clanet, M., & Rascol, O. (1991). Bereitschaftspotential in a simple movement or in a motor sequence starting with the same simple movement. *Electroencephalography and Clinical Neurophysiology*, 81, 129-134. doi:10.1016/0168-5597(91)90006-J

- Smith, E. E., & Jonides, J. (1999). Storage and Executive Processes in the Frontal Lobes. *Science*, 283(5408), 1657-1661. doi: 10.1126/science.283.5408.1657
- Smith, M. L., & Milner, B. (1984). Differential effects of frontal-lobe lesions on cognitive estimation and spatial memory. *Neuropsychologia*, 22, 697-705. doi:10.1016/0028-3932(84)90096-4
- Sokal, R. R. & Rohlf, J. F. (1981). *Biometry: the principles and practice of statistics in biological research*. 2nd ed., W.H. Freeman and Company, San Francisco.
- Soroker, N., Calamaro, N., Glicksohn, J., & Myslobodsky, M. S. (1997). Auditory inattention in right-hemisphere-damaged patients with and without visual neglect. *Neuropsychologia*, 35, 249-256. doi:10.1016/S0028-3932(96)00038-3
- Stelmach, G. E., Phillips, J. G., & Chau, A. W. (1989). Visuo-spatial processing in Parkinsonians. *Neuropsychologia*, 27(4), 485-493. doi: 10.1016/0028-3932(89)90053-5
- Stephan, K. M., Fink, G. R., Passingham, R. E., Silbersweig, D., Ceballos-Baumann, A. O., Frith, C. D., et al. (1995). Functional anatomy of the mental representation of upper extremity movements in healthy subjects. *Journal of Neurophysiology*, 73(1), 373-386. Retrieved from: <http://jn.physiology.org/content/73/1/373.full.pdf>
- Stepkina, D., Zakharov, V., & Yakhno, N. (2010). Cognitive Impairments in Progression of Parkinson's Disease. *Neuroscience and Behavioral Physiology*, 40(1), 61-67. doi:10.1007/s11055-009-9223-6
- Stevens, J. A., & Stoykov, M. E. P. (2003). Using Motor Imagery in the Rehabilitation of Hemiparesis. *Archives of Physical Medicine and Rehabilitation*, 84(7), 1090-1092. doi:10.1016/S0003-9993(03)00042-X
- Stoffers, D., Berendse, H. W., Deijen, J. B., & Wolters, E. Ch. (2003). Deficits on Corsi's block-tapping task in early stage Parkinson's disease. *Parkinsonism & Related Disorders*, 10(2), 107-111. doi:10.1016/S1353-8020(03)00106-8

- Stumpf, H., & Eliot, J. (1999). A structural analysis of visual spatial ability in academically talented students. *Learning and Individual Differences*, 11(2), 137-151.  
doi:10.1016/S1041-6080(00)80002-3
- Subramanian, L., Hindle, J. V., Johnston, S. J., Roberts, M. V., Husain, M., Goebel, R., et al. (2011) Real-Time Functional Magnetic Resonance Imaging Neurofeedback for Treatment of Parkinson's Disease. *The Journal of Neuroscience*, 31, 16309-16317. doi: 10.1523/JNEUROSCI.3498-11.2011
- Swainson, R., SenGupta, D., Shetty, T., Watkins, L. H. A., Summers, B. A., Sahakian, B. J., et al. (2006). Impaired dimensional selection but intact use of reward feedback during visual discrimination learning in Parkinson's disease. *Neuropsychologia*, 44, 1290-1304. doi:10.1016/j.neuropsychologia.2006.01.028
- Tagaris, G. A., Kim, S., Strupp, J. P., Andersen, P., Ugurbil, K., & Georgopoulos, A. P. (1997). Mental rotation studied by functional magnetic resonance imaging at high field (4 tesla): Performance and cortical activation. *J. Cognitive Neuroscience*, 9(4), 419-432.  
doi:10.1162/jocn.1997.9.4.419
- Tamir, R., Dickstein, R., & Huberman, M. (2007). Integration of Motor Imagery and Physical Practice in Group Treatment Applied to Subjects With Parkinson's Disease. *Neurorehabilitation and Neural Repair*, 21(1), 68-75. doi:10.1177/1545968306292608
- Tanji, J. (1996). New concepts of the supplementary motor area. *Current Opinion in Neurobiology*, 6, 782-787. doi:10.1016/S0959-4388(96)80028-6
- Tanji, J., & Shima, K. (1994). Role for supplementary motor area cells in planning several movements ahead. *Nature*, 371, 413-416. doi:10.1038/371413a0
- Tarr, M. J., & Pinker, S. (1990). When Does Human Object Recognition Use a Viewer-Centered Reference Frame? *Psychological Science*, 1, 253-256. doi: 10.1111/j.1467-9280.1990.tb00209.x



- Taylor, A. E., & Saint-Cyr, J. A. (1995). The neuropsychology of Parkinson's disease. *Brain and Cognition*, 28, 281-296. doi: 10.1006/brcg.1995.1258
- Taylor, A. E., Saint-Cyr, J. A., & Lang, A. E. (1990). Memory and learning in early Parkinson's disease: Evidence for a "frontal lobe syndrome". *Brain and Cognition*, 13, 211-232. doi:10.1016/0278-2626(90)90051-O
- Thaler, D., Chen, Y. C., Nixon, P. D., Stern, C. E., & Passingham, R. E. (1995). The functions of the medial premotor cortex. *Experimental Brain Research*, 102, 445-460. doi:10.1007/BF00230649
- Thickbroom, G. W., Byrnes, M. L., Sacco, P., Ghosh, S., Morris, I. T., & Mastaglia, F. L. (2000). The role of the supplementary motor area in externally timed movement: the influence of predictability of movement timing. *Brain Research*, 874, 233-241. doi:10.1016/S0006-8993(00)02588-9
- Thobois, S., Dominey, P. F., Decety, J., Pollak, P., Gregoire, M. C., Bars, D. Le, et al. (2000). Motor imagery in normal subjects and in asymmetrical Parkinson's disease. *Neurology*, 55, 996-1002. doi:10.1212/WNL.55.7.996
- Tomer, R., Levin, B. E., & Weiner, W. J. (1993). Side of onset of motor symptoms influences cognition in Parkinson's disease. *Annals of Neurology*, 34, 579-584. doi:10.1002/ana.410340412
- Tremblay, P., & Gracco, V. L. (2006). Contribution of the frontal lobe to externally and internally specified verbal responses: fMRI evidence. *NeuroImage*, 33, 947-957. doi:10.1016/j.neuroimage.2006.07.041
- Turnbull, O. H., & McCarthy, R. A. (1996). When is a view unusual? A single case study of orientation-dependent visual agnosia. *Brain Research Bulletin*, 40, 497-502. doi: 10.1016/0361-9230(96)00148-7

- Turner, R. S., Grafton, S. T., McIntosh, A. R., DeLong, M. R., & Hoffman, J. M. (2003). The functional anatomy of parkinsonian bradykinesia. *NeuroImage*, *19*(1), 163-179.  
doi:10.1016/S1053-8119(03)00059-4
- Uc, E. Y., Rizzo, M., Anderson, S. W., Sparks, J. D., Rodnitzky, R. L., & Dawson, J. D. (2007). Impaired navigation in drivers with Parkinson's disease. *Brain*, *130*, 2433-2440.  
doi:10.1093/brain/awm178
- Ullsperger, M., & von Cramon, D. Y. (2001). Subprocesses of Performance Monitoring: A Dissociation of Error Processing and Response Competition Revealed by Event-Related fMRI and ERPs. *NeuroImage*, *14*, 1387-1401. doi:10.1006/nimg.2001.0935
- Ungerleider, L.G. & Mishkin, M. (1982). Two cortical visual systems. In *Analysis of Visual Behavior* Cambridge, MA: MIT Press.
- Vale, S. (2008). Current Management of the Cognitive Dysfunction in Parkinson's Disease: How Far Have We Come? *Experimental Biology and Medicine*, *233*, 941-951.  
doi:10.3181/0707-MR-193
- Vingerhoets, G., de Lange, F. P., Vandemaele, P., Deblaere, K., & Achten, E. (2002). Motor Imagery in Mental Rotation: An fMRI Study. *NeuroImage*, *17*, 1623-1633.  
doi:10.1016/j.neuroimage.2007.04.012
- Vingerhoets, G., Santens, P., Van Laere, K., Lahorte, P., Dierckx, R. A., & De Reuck, J. (2001). Regional Brain Activity during Different Paradigms of Mental Rotation in Healthy Volunteers: A Positron Emission Tomography Study. *NeuroImage*, *13*, 381-391.  
doi:10.1006/nimg.2000.0690
- Wallesch, C-W, Karnath, H. O., & Zimmermann, P. (1992). Is there a frontal lobe dysfunction in Parkinson's disease? A comparison of the effects of Parkinson's disease and circumscribed frontal lobe lesions in a maze learning task. In *Subcortical Disorders Associated with Subcortical Lesions*, Oxford: Oxford University Press.

- Wechsler, D. (1999). *Wechsler Abbreviated Scale of Intelligence*. San Antonio, TX :The Psychological Corporation.
- Wechsler, David. (1955). *Manual for the Wechsler adult intelligence scale*. Oxford, England: Psychological Corp.
- Weeks, R., Horwitz, B., Aziz-Sultan, A., Tian, B., Wessinger, C. M., Cohen, L. G., et al. (2000). A Positron Emission Tomographic Study of Auditory Localization in the Congenitally Blind. *The Journal of Neuroscience*, 20, 2664-2672. doi: 0270-6474/00/202664-09
- Wexler, M., Kosslyn, S. M., & Berthoz, A. (1998). Motor processes in mental rotation. *Cognition*, 68, 77-94. doi:10.1016/S0010-0277(98)00032-8
- Wiesendanger, M. (1993). The riddle of supplementary motor area function. In: Mano N, Hamada, I., DeLong, M. R. (eds) *Role of the cerebellum and basal ganglia in voluntary movement*. Elsevier, Amsterdam, 253–266.
- Willems, B., & Wagemans, J. (2001). Matching multicomponent objects from different viewpoints: Mental rotation or normalization? *Journal of Experimental Psychology: Human Perception and Performance*, 27, 1090-1115. doi:10.1037/0096-1523.27.5.1090
- Williams, L. N., Seignourel, P., Crucian, G. P., Okun, M. S., Rodriguez, R. L., Skidmore, F. M., et al. (2007). Laterality, region, and type of motor dysfunction correlate with cognitive impairment in Parkinson's disease. *Movement Disorders*, 22, 141-144. doi:10.1002/mds.21220
- Windischberger, C., Lamm, C., Bauer, H., & Moser, E. (2003). Human motor cortex activity during mental rotation. *NeuroImage*, 20, 225-232. doi:10.1016/S1053-8119(03)00235-0
- Wise, S. P. (1985). The Primate Premotor Cortex: Past, Present, and Preparatory. *Annual Review of Neuroscience*, 8, 1-19. doi:10.1146/annurev.neuro.8.1.1

- Wohlschlagel, A., & Wohlschlagel, A. (1998). Mental and manual rotation. *Journal of Experimental Psychology: Human Perception and Performance*, *24*, 397-412.  
doi:10.1037//0096-1523.24.2.397
- Wright, M. J., Burns, R. J., Geffen, G. M., & Geffen, L. B. (1990). Covert orientation of visual attention in Parkinson's disease: An impairment in the maintenance of attention. *Neuropsychologia*, *28*, 151-159. doi:10.1016/0028-3932(90)90097-8
- Yágüez, L., Canavan, A. G. M., Lange, H. W., & Hömberg, V. (1999). Motor learning by imagery is differentially affected in Parkinson's and Huntington's diseases. *Behavioural Brain Research*, *102*, 115-127. doi:10.1016/S0166-4328(99)00005-4
- Yesavage, J. A., Brink, T. L., Rose, T. L., Lum, O., Huang, V., Adey, M., et al. (1982). Development and validation of a geriatric depression screening scale: A preliminary report. *Journal of Psychiatric Research*, *17*, 37-49. doi:10.1016/0022-3956(82)90033-4
- Zacks, J. M. (2008). Neuroimaging studies of mental rotation: A meta-analysis and review. *Journal Cognitive Neuroscience*, *20*, 1-19. doi:10.1162/jocn.2008.20013
- Zahrt, J., Taylor, J. R., Mathew, R. G., & Arnsten, A. F. T. (1997). Supranormal Stimulation of D1 Dopamine Receptors in the Rodent Prefrontal Cortex Impairs Spatial Working Memory Performance. *The Journal of Neuroscience*, *17*, 8528-8535. doi:10.1016/S0091-3057(96)00477-7
- Zanini, S., Melatini, A., Capus, L., Gioulis, M., Vassallo, A., & Bava, A. (2003). Language recovery following subthalamic nucleus stimulation in Parkinson's disease. *NeuroReport*, *14*, 511-516.
- Zetuský, W. J., Jankovic, J., & Pirozzolo, F. J. (1985). The heterogeneity of Parkinson's disease: Clinical and prognostic implications. *Neurology*, *35*, 522.  
doi:10.1212/WNL.35.4.522

Zgaljardic, D. J., Foldi, N. S., & Borod, J. C. (2004). Cognitive and behavioral dysfunction in Parkinson's disease: neurochemical and clinicopathological contributions. *Journal of Neural Transmission, 111*, 1287-1301. doi: 10.1007/s00702-004-0178-z

## Appendices

### Appendix A

Visuospatial transformation impairments in Parkinson's disease Julie H. Kerai, et al. 2012.

### Appendix B

Subsets of the Unified Parkinson's disease Rating Scale

**Appendix B**                      **Subsets of the Unified Parkinson's disease Rating Scale**

**II. ACTIVITIES OF DAILY LIVING (DETERMINE FOR "ON/OFF")**

**5. *Speech:***

0 = Normal.

1= Mildly affected. No difficulty being understood.

2= Moderately affected. Sometimes asked to repeat statements. 3=Severely affected.

Frequently asked to repeat statements. 4=Unintelligible most of the time.

**6. *Salivation:***

0= Normal.

1= Slight but definite excess of saliva in mouth; may have nighttime drooling.

2= Moderately excessive saliva; may have minimal drooling.

3= Marked excess of saliva with some drooling.

4= Marked drooling, requires constant tissue or handkerchief.

**7. *Swallowing:***

0=Normal.

1= Rare choking.

2=Occasional choking.

3=Requires soft food.

4= Requires NG tube or gastrostomy feeding.

**8. *Handwriting:*** 0=Normal.

1=Slightly slow or small.

2= Moderately slow or small; all words are legible.

3=Severely affected; not all words are legible.

4=The majority of words are not legible.

**9. *Cutting food and handling utensils:***

0=Normal.

1=Somewhat slow and clumsy, but no help needed.

2=Can cut most foods, although clumsy and slow; some help needed.

3=Food must be cut by someone, but can still feed slowly.

4=Needs to be fed.

**10. Dressing:**

0=Normal.

1=Somewhat slow, but no help needed.

2=Occasional assistance with buttoning, getting arms in sleeves.

3=Considerable help required, but can do some things alone.

4 =Helpless.

**11. Hygiene:**

0 = Normal.

1 =Somewhat slow, but no help needed.

2=Needs help to shower or bathe; or very slow in hygienic care.

3= Requires assistance for washing, brushing teeth, combing hair, going to bathroom.

4 =Foley catheter or other mechanical aids.

**12. Turning in bed and adjusting bedclothes:**

0 =Normal.

1 =Somewhat slow and clumsy, but no help needed.

2 =Can turn alone or adjust sheets, but with great difficulty.

3 =Can initiate, but not turn or adjust sheets alone.

4 =Helpless.

**13. Falling. (unrelated to freezing):**

0 =None.

1 =Rare falling.

2 =Occasionally falls, less than once per day.

3 =Falls an average of once daily.

4 =Falls more than once daily.

**14. Freezing when walking:**

0 =None.

1 =Rare freezing when walking; may have start-hesitation.

2 =Occasional freezing when walking.

3= Frequent freezing. Occasionally falls from freezing.

4 =Frequent falls from freezing.



**15. Walking:**

0 = Normal.

1 = Mild difficulty. May not swing arms or may tend to drag leg.

2 = Moderate difficulty, but requires little or no assistance.

3 = Severe disturbance of walking, requiring assistance.

4 = Cannot walk at all, even with assistance.

**16. Tremor:**

0 = Absent.

1 = Slight and infrequently present.

2 = Moderate; bothersome to patient.

3 = Severe; interferes with many activities.

4 = Marked; interferes with most activities.

**17. Sensory complaints related to parkinsonism:**

0 = None.

1 = Occasionally has numbness, tingling, or mild aching.

2 = Frequently has numbness, tingling, or aching; not distressing.

3 = Frequent painful sensations.

4 = Excruciating pain.

**III. MOTOR EXAMINATION**

**18. Speech:**

0 = Normal.

1 = Slight loss of expression, diction and/ or volume.

2 = Monotone, slurred but understandable; moderately impaired.

3 = Marked impairment, difficult to understand.

4 = Unintelligible.

**19. Facial expression:**

0 = Normal.

1 = -- Minimal hypomimia, could be normal "Poker Face".

2 = Slight but definitely abnormal diminution of facial expression.

3 = Moderate hypomimia; lips parted some of the time.

4 = Masked or fixed facies with severe or complete loss of facial expression; lips parted 1/4 inch or more.

**20. Tremor at rest:**

0 = Absent.

1 = Slight and infrequently present.

2 = Mild in amplitude and persistent. Or moderate in amplitude, but only intermittently present.

3 = Moderate in amplitude and present most of the time.

4 = Marked in amplitude and present most of the time.

**21. Action or postural tremor of hands:**

0 = Absent.

1 = Slight; present with action.

2 = Moderate in amplitude, present with action.

3 = Moderate in amplitude with posture holding as well as action.

4 = Marked in amplitude; interferes with feeding.

**22. Rigidity: (Judged on passive movement of major joints with patient relaxed in sitting position. Cogwheeling to be ignored.)**

0 = Absent.

1 = Slight or detectable only when activated by mirror or other movements.

2 = Mild to moderate.

3 = Marked, but full range of motion easily achieved.

4 = Severe, range of motion achieved with difficulty.

**23. Finger taps: (Patient taps thumb with index finger in rapid succession with widest amplitude possible, each hand separately.)**

0 = Normal.

1 = Mild slowing and/or reduction in amplitude.

2 = Moderately impaired. Definite and early fatiguing. May have occasional arrests in movement.

3 = Severely impaired. Frequent hesitation in initiating movements or arrests in ongoing movement.

4 = Can barely perform the task.

**24. Hand movements: (Patient opens and closes hands in rapid succession with widest amplitude possible, each hand separately.)**

0 =Normal.

1= Mild slowing and/or reduction in amplitude.

2= Moderately impaired. Definite and early fatiguing. May have occasional arrests in movement.

3 =Severely impaired. Frequent hesitation in initiating movements or arrests in ongoing movement.

4 =Can barely perform the task.

**25. Rapid alternating movements of hands: (Pronation-supination movements of hands, vertically or horizontally, with as large an amplitude as possible, both hands simultaneously.)**

0 =Normal.

I =Mild slowing and/or reduction in amplitude.

2= Moderately impaired. Definite and early fatiguing. May have occasional arrests in movement.

3 =Severely impaired. Frequent hesitation in initiating movements or arrests in ongoing movement.

4 =Can barely perform the task.

**26. Leg agility: (Patient taps heel on ground in rapid succession, picking up entire leg. Amplitude should be about 3 inches.)**

0 = Normal.

1= Mild slowing and/or reduction in amplitude.

2=Moderately impaired. Definite and early fatiguing. May have occasional arrests in movement.

3 =Severely impaired. Frequent hesitation in initiating movements or arrests in ongoing movement.

4 =Can barely perform the task.

**27. Arising from chair: (Patient attempts to arise from a straight-back wood or metal chair with arms folded across chest.)**

0 =Normal.

I =Slow; or may need more than one attempt.

2 =Pushes self up from arms of seat.

## VECTOR TRANSFORMATION IN PRE-SMA

3 =Tends to fall back and may have to try more than one time, but can get up without help.

4 = Unable to arise without help.

### **28. Posture:**

0 =Normal erect.

1 =Not quite erect, slightly stooped posture; could be normal for older person.

2=Moderately stooped posture, definitely abnormal; can be slightly leaning to one side.

3 =Severely stooped posture with kyphosis; can be moderately leaning to one side.

4 =Marked flexion with extreme abnormality of posture.

### **29 Gait:**

0= Normal.

1= Walks slowly, may shuffle with short steps. but no festination or propulsion.

2= Walks with difficulty, but requires little or no assistance; may have some festination, short steps, or propulsion.

3 = Severe disturbance of gait, requiring assistance.

4=Cannot walk at all, even with assistance.

### **30. Postural stability:(Response to sudden posterior displacement produced by pull on shoulders while patient erect with eyes open and feet slightly apart. Patient is prepared.)**

0=Normal.

1= Retropulsion, but recovers unaided.

2=Absence of postural response; would fall if not caught by examiner. 3 =Very unstable, tends to lose balance spontaneously.

4= Unable to stand without assistance.

### **31. Body bradykinesia and hypokinesia: (Combining slowness, hesitancy, decreased armswing, small amplitude, and poverty of movement in general.)**

0 = None.

1= Minimal slowness, giving movement a deliberate character; could be normal for some persons. Possibly reduced amplitude.

2= Mild degree of slowness and poverty of movement which is definitely abnormal. Alternatively, some reduced amplitude.

3 = Moderate slowness, poverty or small amplitude of movement.

4 = Marked slowness, poverty or small amplitude of movement.

