

# A Psychophysiological Acquisition Device for Affective Video Games



PRIFYSGOL  
**BANGOR**  
UNIVERSITY

Thomas Christy

School of Computer Science

Bangor University

Thesis submitted in candidate for the degree of

*Doctor of Philosophy*

September 2014

# Declaration and Consent

I hereby agree to deposit the following item in the digital repository maintained by Bangor University and/or in any other repository authorized for use by Bangor University.

**Author Name:** Thomas Christy.

**Title:** A Psychophysiological Acquisition Device for Affective Video Games

**Supervisor/Department:** Professor Ludmila I. Kuncheva / School of Computer Science.

**Funding body (if any):**

**Qualification/Degree obtained:** PhD.

This item is a product of my own research endeavours and is covered by the agreement below in which the item is referred to as "the Work". It is identical in content to that deposited in the Library, subject to point 4 below.

## **Non-exclusive Rights**

Rights granted to the digital repository through this agreement are entirely non-exclusive. I am free to publish the Work in its present version or future versions elsewhere. I agree that Bangor University may electronically store, copy or translate the Work to any approved medium or format for the purpose of future preservation and accessibility. Bangor University is not under any obligation to reproduce or display the Work in the same formats or resolutions in which it was originally deposited.

## **Bangor University Digital Repository**

I understand that work deposited in the digital repository will be accessible to a wide variety of people and institutions, including automated agents and search engines via the World Wide Web.

I understand that once the Work is deposited, the item and its metadata may be incorporated into public access catalogues or services, national databases of electronic theses and dissertations such as the

---

British Library's EThOS or any service provided by the National Library of Wales.

I understand that the Work may be made available via the National Library of Wales Online Electronic Theses Service under the declared terms and conditions of use <http://www.llgc.org.uk/.php?id=4676>. I agree that as part of this service the National Library of Wales may electronically store, copy or convert the Work to any approved medium or format for the purpose of future preservation and accessibility. The National Library of Wales is not under any obligation to reproduce or display the Work in the same formats or resolutions in which it was originally deposited.

**Statement 1:**

This work has not previously been accepted in substance for any degree and is not being concurrently submitted in candidature for any degree unless as agreed by the University for approved dual awards.

Signed ..... (Thomas Christy)

Date : 30 September 2014 .

**Statement 2:**

This thesis is the result of my own investigations, except where otherwise stated. Where correction services have been used, the extent and nature of the correction is clearly marked in a footnote(s).

All other sources are acknowledged by footnotes and/or a bibliography.

Signed ..... (Thomas Christy)

Date : 30 September 2014 .

**Statement 3:**

I hereby give consent for my thesis, if accepted, to be available for photocopying, for inter-library loan and for electronic repositories, and for the title and summary to be made available to outside organisations.

Signed ..... (Thomas Christy)

Date : 30 September 2014 .

---

**NB:** Candidates on whose behalf a bar on access has been approved by the Academic Registry should use the following version of **Statement 3:**

**Statement 3 (bar):**

I hereby give consent for my thesis, if accepted, to be available for photocopying, for inter-library loans and for electronic repositories after expiry of a bar on access.

Signed ..... (Thomas Christy)

Date : 30 September 2014 .

**Statement 4:**

Choose **one** of the following options.

a) I agree to deposit an electronic copy of my thesis (the Work) in the Bangor University (BU) Institutional Digital Repository, the British Library ETHOS system, and/or in any other repository authorized for use by Bangor University and where necessary have gained the required permissions for the use of third party material.	
b) I agree to deposit an electronic copy of my thesis (the Work) in the Bangor University (BU) Institutional Digital Repository, the British Library ETHOS system, and/or in any other repository authorized for use by Bangor University when the approved <b>bar on access</b> has been lifted.	
c) I agree to submit my thesis (the Work) electronically via Bangor University's e-submission system, however I <b>opt-out</b> of the electronic deposit to the Bangor University (BU) Institutional Digital Repository, the British Library ETHOS system, and/or in any other repository authorized for use by Bangor University, due to lack of permissions for use of third party material.	

*Options B should only be used if a bar on access has been approved by the University*

**In addition to the above I also agree to the following:**

1. That I am the author or have the authority of the author(s) to make this agreement and do hereby give Bangor University the right to make available the Work in the way described above.
2. That the electronic copy of the Work deposited in the digital repository and covered by this agreement, is identical in content to the paper copy of the Work deposited in the Bangor University Library, subject to point 4 below.
3. That I have exercised reasonable care to ensure that the Work is original and, to the best of my knowledge, does not breach any laws including those relating to defamation, libel and copyright.

- 
4. That I have, in Instances where the intellectual property of other authors or copyright holders is included in the Work, and where appropriate, gained explicit permission for the inclusion of that material in the Work, and in the electronic form of the Work as accessed through the open access digital repository, or that I have identified and removed that material for which adequate and appropriate permission has not been obtained and which will be inaccessible via the digital repository.
  5. That Bangor University does not hold any obligation to take legal action on behalf of the Depositor, or other rights holders, in the event of a breach of intellectual property rights, or any other right, in the material deposited.
  6. That I will indemnify and keep indemnified Bangor University and the National Library of Wales from and against any loss, liability, claim or damage, including without limitation any related legal fees and court costs (on a full indemnity bases), related to any breach by myself of any term of this agreement.

Signature: .....

Date : 30 September 2014 .

I dedicate this work to my wife, Rachel Christy, and to my children, Elisha, Zak and Jake for their love, inspiration, and unwavering and uncompromising belief in me.

*“Never give up”*

## **Acknowledgements**

My thanks is given to the Coleg Cymraeg Cenedlaethol for financing my PhD studies, thus enabling me to pursue a reputable qualification and alter the course of the future for my family.

I express gratitude and thanks to my supervisor Professor Lucy I. Kuncheva for persevering with me and steering my innate curiosity, with care and patience throughout my PhD research, and for believing in me.

I wish to thank the following for their support and guidance: Dr. Sa'ad Mansoor for his friendship, guidance and support throughout the entire duration of my PhD. Dr. Iestyn Pierce and Aled Williams for their technical support, in creating the electronics for the project. Dr. Dewi Rowlands for his design advice and guidance, including the use of the Design and Technology department in facilitating the prototype (when 3D printers were scarce). Dr. Rafal Mantiuk for his supervisory assistance. Dr. Julienne Law for keeping my mind in perspective. A special thanks goes to Haider K. Easa for his true friendship and inspiration, in particular his benignity and true example of strength during adversity, not to mention his ability to show me the single tree amongst the forest. My humble thanks goes to my friend Yasser Alghurabi, for his true kindness and generosity of heart. Thanks also goes to the following, for their comradery and being a part of my journey: Robart Wanat for being an extraordinary reference, beyond Google. Dr. Gary M.Y. Hung for showing me a path when no path existed.

And of course, last but no where near least, my utmost gratitude and love is given to my inspiration, rock and the source of my unbreakable strength, my wife and kids, for being there throughout, by giving me so much and giving-up so much, and still being here at the end.

## **Abstract**

The importance of emotions for normal communicative behaviour has been realised in computational sciences since 1999. Affective computing aims to accommodate the need for emotions in two-way human computer interactions. Interactivity forms the foundation of computer video games. Engaging emotions into video games is an attractive proposition, for both developers and game players. Affective gaming forms a growing field of research in computer science, which relies heavily on affective acquisition devices. Input devices for affective gaming are woefully under-invested, particularly given the longevity of the underlying technologies.

This thesis explores the reasons for this delayed uptake and determines what factors are required to meliorate the affective gaming domain. The most widely used sensors available for affect detection are surveyed, and an overview of different affect detection methods is given.

Subsequently, the design and development of a psychophysiological acquisition device is described. The device focuses on the interactive and functional qualities required for an affective gaming input device. Owing to its novel design features, it was named the Shark-Fin mouse.

Three psychophysiological sensors are selected for their sensitivity to change in emotional states and which are suitable to be applied to an input device. The Shark-Fin mouse utilises electrodermal activity, blood volume (pulse) and temperature. The mouse is designed to take advantage of 3D printing technologies, to empower digital distribution and home-manufacturing.

As well as acquiring psychophysiological signals, the main premise of the device was to be easily used, without set-up procedures, tapes, straps or gels. In addition, a fully functional video game was developed to subject



the new input system to an active video game environment. The game was designed to provoke mild levels of frustration. The game formed part of an experiment to validate the functionality of the Shark-Fin mouse, as both an input device and an affect acquisition tool. Along with game-state variables, specific event-based data was recorded for analysis.

The thesis concludes with empirical analysis. We employed classification techniques, to determine if any recognisable patterns within the psychophysiological data exist, in correlation to the game-state data collected.

The final results determine that the Shark-Fin mouse offers a novel and useful system for affect acquisition. Further, the psychophysiological signals are validated during active video game play sessions.

# Contents

<b>1</b>	<b>Introduction</b>	<b>1</b>
1.1	Hypothesis . . . . .	3
1.2	Chapter structure and hypotheses . . . . .	4
1.3	Contributions . . . . .	6
1.4	Publications . . . . .	7
<b>2</b>	<b>Advancements in Affective Gaming</b>	<b>8</b>
2.1	Introduction . . . . .	8
2.1.1	Affective Computing . . . . .	9
2.1.2	Emotional States . . . . .	9
2.1.3	Ethical Perspective . . . . .	10
2.1.4	Affective Gaming . . . . .	11
2.2	Emotion as an input . . . . .	13
2.3	Affect acquisition . . . . .	15
2.3.1	Behavioural . . . . .	15
2.3.2	Physiological . . . . .	18
2.3.3	Nervous systems . . . . .	18
2.3.4	Physiological modalities . . . . .	21
2.3.5	Sensors and devices . . . . .	23
2.4	Commercial Affective Gaming . . . . .	27
2.5	Utilising Affective Data . . . . .	29
2.5.1	Generations of console platforms . . . . .	30
2.5.2	Commercial Affective Video Games . . . . .	32
2.5.3	Graphical advancements . . . . .	38
2.5.4	Commercial Interests . . . . .	40

2.6	Summary . . . . .	42
<b>3</b>	<b>Building Shark-Fin</b>	<b>44</b>
3.1	Sensors . . . . .	44
3.1.1	Electrodermal activity . . . . .	45
3.1.2	Photoplethysmography . . . . .	45
3.1.3	Temperature . . . . .	46
3.1.4	Final System . . . . .	47
3.2	Hardware . . . . .	48
3.2.1	Early Prototype . . . . .	48
3.2.2	Experiment . . . . .	51
3.2.3	Interim Results . . . . .	53
3.2.4	Final hardware . . . . .	54
3.3	Ergonomic Design (Shark Fin) . . . . .	58
3.4	Testing and Verification . . . . .	65
3.5	Discussion of Results . . . . .	70
<b>4</b>	<b>Game &amp; User Trials</b>	<b>71</b>
4.1	Serious Video Games . . . . .	71
4.2	Video games . . . . .	71
4.3	Stimulating Affect Change . . . . .	72
4.4	Game Concept . . . . .	72
4.4.1	Interim Experiment Results . . . . .	75
4.5	Enhanced Full Game . . . . .	79
4.5.1	The video game . . . . .	79
4.5.2	Experimental set up . . . . .	81
4.5.3	The experimental environment . . . . .	84
4.5.4	Data logging . . . . .	88
4.6	Summary . . . . .	90
<b>5</b>	<b>Psychophysiological Data Analysis</b>	<b>91</b>
5.1	Feature extraction . . . . .	91
5.2	Visual Overview . . . . .	93
5.3	Classification methods. . . . .	97

## CONTENTS

---

5.4	Rest versus game-play . . . . .	101
5.5	Event recognition . . . . .	102
5.6	Summary . . . . .	105
<b>6</b>	<b>Conclusion</b>	<b>109</b>
6.1	Summary of Work . . . . .	109
6.2	Future work . . . . .	111
<b>A</b>	<b>Signal Transmit Code</b>	<b>114</b>
A.1	FEZ domino/mini code (firmware) . . . . .	114
A.2	Matlab Code . . . . .	117
<b>B</b>	<b>Circuit Diagrams</b>	<b>119</b>
<b>C</b>	<b>Weka Output Result</b>	<b>121</b>
C.1	Result Tables . . . . .	121
<b>D</b>	<b>Code Highlights</b>	<b>124</b>
D.1	Code . . . . .	124
	<b>References</b>	<b>130</b>

# List of Figures

2.1	The real-time affective gaming (AG) loop. . . . .	12
2.2	Input modality human connectivity comparison, showing physiological and behavioural divide. . . . .	16
2.3	Nervous system pathways . . . . .	19
2.4	Atari Mindlink flyer, image courtesy of <a href="http://www.atarimuseum.com">www.atarimuseum.com</a> . . . . .	28
2.5	Calmpute Mantra <a href="#">Electro Dermal Activity (EDA)</a> input device (a) and CalmPute CalmPrix affective game (b). . . . .	28
2.6	Time-line view of AG research publications. Publications addressing bespoke psychophysiological hardware are shown in a lighter shade. . . . .	31
2.7	Video game console time-line representing the introduction and commercial duration of each console generation, shown in segments. Key commercial contributions are indicated pinpointing the year of release. Given in brackets are the names of the relevant companies. . . . .	36
2.8	Graphic card technology advancement since 1997 beginning in 1997 at 100 mega-texels (MT) and growing exponentially to 1,875,000 MT by mid-2013. The vertical axis is $\log_{10}(y)$ , where $y$ represents maximum MT per year. . . . .	39
2.9	Graphics advancement timeline, highlighting a historical overview of video graphic card advancements, depicting significant graphics hardware and software contributions. . . . .	41
3.4	First Proof of concept prototype using low cost. . . . .	52

## LIST OF FIGURES

---

3.5	Custom circuit, fitted with <a href="#">EDA</a> and Blood Volume circuits on one board. Built by Dr. Aled Williams, Bangor Univeristy, by modifying the original Maplin (N56FL) Pulse Rate Monitor kit to return the pulsed waveform. . . . .	55
3.6	MLX90614 IR Thermometer evaluation board transmits IR detected temperature to TX UART port in Fahrenheit. . . . .	56
3.8	SharkFin mouse system diagram . . . . .	58
3.9	Point of continuous contact between hand and mouse highlighted green. . . . .	60
3.14	. . . . .	63
3.15	AMBER Shark-fin Mouse . . . . .	64
3.16	SharkFin mouse signal taken over 60 seconds during play . . . . .	65
3.17	IR-Temperature 10s hand, 10s ice, 10s coffee . . . . .	66
3.18	Heart Rate, 30 sec with 5sec covered 5sec uncovered repeatedly . . . . .	67
3.19	Electro-dermal activity, 30 sec with 5sec off 5sec on repeatedly . . . . .	68
3.20	Heart rate (top), <a href="#">EDA</a> (middle), Temperature (Bottom) . . . . .	69
4.1	Simple graphical sprites (assets) representing Target (a), Obstacle (b) and number of lives (c). . . . .	73
4.2	First draft proof of concept Affective Game environment. . . . .	74
4.3	Polygons for classes ‘Calm’ and ‘Agitated’ for the Pulse Rate . . . . .	77
4.4	Polygons for classes ‘Calm’ and ‘Agitated’ for the <a href="#">EDA</a> . . . . .	78
4.5	Polygons for classes ‘Calm’ and ‘Agitated’ for the Skin Temperature . . . . .	78
4.6	A screenshot from the video game. . . . .	80
4.7	Video game in action, depicting a screenshot of the standard video game. . . . .	81
4.8	Video-game screen-shot showing meteor and asteroid trajectory lines, including faded collision distances. . . . .	82
4.9	Debug mode, which shows collision interaction game parameters, and removes moving space background. . . . .	83
4.10	Instructions shown to the player before the game commenced. . . . .	84
4.11	The experimental environment . . . . .	85
4.12	Videogame experiment booth, highlighting the participant uninterrupted view. . . . .	86

## LIST OF FIGURES

---

4.13	The data capture graphical user interface. Showing the data from the entire duration of the game. Depicting Pulse (top, red), EDA (middle, green) and temperature (bottom, blue). . . . .	87
4.14	Video game assets, which are animated during game play; target (a), meteor (b), asteroid (c), player sprite/life (d) and moving nebula background (d). . . . .	89
5.1	Augmented data plot key . . . . .	94
5.2	Augmented data plot time-line: showing a plot of all streams data combined; three physiological signals, game state variable values (such as score, lives, energy, etc.) and triggered 'events', see Key in Figure 5.1. Such that, all the data was overlaid together on the same time-line. Heart rate peaks displayed with black dots. . . . .	95
5.3	The point of change in Blood Volume Amplitude level variance, between fixation period (cyan) and level 9 game-play (green), including the correlation with EDA variance (blue), demonstrating a clear physiological response. . .	96
B.1	Heart rate amplification and smoothing circuit diagram. . . . .	119
B.2	Electrodermal circuit diagram. . . . .	120
D.1	Depiction of the motion when implementing the Cartesian rotation algorithm. . . . .	129

# List of Tables

2.1	Early period devices suitable for affective computing. . . . .	24
2.2	Affective gaming modalities and the current academic contributors in order of year. . . . .	33
2.3	Dekker & Champion visual effects and physiological threshold conditions; used in the modified video game <i>Half Life 2</i> . . . . .	34
2.4	Dekker & Champion conditions applied to psychophysiological threshold criteria in the video game <i>Half Life 2</i> . . . . .	34
2.5	Effects of game speed of <i>Pacman</i> , based on psychophysiological data input . . . . .	35
3.1	Classifiers and classifier ensembles used with the AMBER data. . . .	53
3.2	Classification accuracy from the 10-fold cross-validation . . . . .	54
3.3	Temperature range (°F) . . . . .	67
4.1	Example of game state data structure saved, during game play . . . .	74
4.2	Game state EVENT data. . . . .	88
4.3	Game state EVENT decimal binary key. . . . .	89
5.1	Features extracted from the physiological data streamed by the affective mouse. . . . .	92
5.2	Classification accuracies (in %) for the Rest/Play experiment. . . . .	102
5.3	Event comparisons using Wilcoxon signed-rank test with Bonferroni correction. . . . .	104



## LIST OF TABLES

---

5.4	Number of events and their respective number of occurrences, with >5000 highlighted bold and marked with ✓. Events related to Meteor (64) & Asteroid (128) strikes shaded grey. The × marks the individual corresponding events. The event's name key is given in Table 4.3. . . .	106
5.5	Classification accuracy % for EVENT_ 4 TEN_ SECOND_ TIMER_ BEEP . . . . .	107
5.6	Average classification accuracy % for EVENT_ 288 – TOUCHED_ BALL_ EVENT + SCORED_ EVENT, with highest underlined. . . .	107
C.1	Classification accuracy % for EVENT_ 4 – TEN_ SECOND_ TIMER_ BEEP . . . . .	121
C.2	Classification accuracy % for EVENT_ 288 – (TOUCHED_ BALL_ EVENT + SCORED_ EVENT) . . . . .	122
C.3	Classification accuracy % for EVENT_4160 – (LOSE_ ENERGY_ EVENT + TOUCHED_ METEOR_ EVENT) . . . . .	122
C.4	Classification accuracy % for EVENT_ 6144 – (BUZZ_ EVENT + LOSE_ ENERGY_ EVENT) . . . . .	123
C.5	Classification accuracy % for EVENT_ 131072 – (ZAP_ EVENT) . . . . .	123

# Acronyms

**AC** Affective Computing. [xvii](#), [1](#), [9](#), [11](#)

**AG** Affective Gaming. [xvii](#), [1](#), [2](#), [11](#), [113](#)

**CORR** Corrugator Supercilii Muscle. [xvii](#), [36](#)

**ECG** Electrocardiogram. [xvii](#), [34](#)

**EDA** Electro Dermal Activity. [xii–xiv](#), [xvii](#), [21](#), [22](#), [25–30](#), [34](#), [35](#), [38](#), [43](#), [44](#), [47–50](#), [53](#), [57](#), [59](#), [61](#), [63](#), [65](#), [67](#), [69–71](#), [78–80](#), [89](#), [91](#), [94](#), [98](#), [99](#)

**EEG** Electroencephalography. [xvii](#), [20](#), [21](#), [34](#), [53](#), [55](#), [56](#)

**EMG** Electromyography. [xvii](#), [23](#), [26](#), [28](#), [34](#), [43](#)

**EOG** Electrooculography. [xvii](#), [34](#)

**GSR** Galvanic Skin Response. [xvii](#), [21](#)

**HCI** Human Computer Interaction. [xvii](#), [1](#), [2](#), [9](#), [17](#), [111](#)

**HR** Heart Rate. [xvii](#), [27](#), [30](#), [34–36](#), [38](#), [43](#), [44](#), [78](#)

**HS** Heart Sound. [xvii](#), [34](#)

**ICG** Impedance Cardiogram. [xvii](#), [34](#)

**PGR** Psycho Galvanic Reflex. [xvii](#), [21](#)

**PPG** Photoplethysmography. [xvii](#), [22](#), [23](#), [34](#), [47](#), [49–51](#), [61](#), [81](#), [94](#), [98](#), [99](#)

**SCL** Skin Conductance. [xvii](#), [36](#)

**SCR** Skin Conductance Rate. [xvii](#), [21](#), [36](#)

**VG** Video Games. [xvii](#), [1](#), [2](#), [24](#), [56](#)

**ZYG** Zygomaticus Major Muscle. [xvii](#), [36](#)

# Chapter 1

## Introduction

Emotions are described as an important facet in human interactions [25, 59]. They define normal communicative behaviour. Emotions are innate somatic sensations that are felt internally but outwardly manifest through behavioural and physiological means, both voluntarily and involuntarily. The inability to expressly imitate or respond to emotions during human communication is prominent in neural development disorders, such as Autism, Asperger Syndrome, etc.

Historically, [Human Computer Interaction \(HCI\)](#) have mostly been devoid of this innate human requirement. Combining emotions with computer systems forms a growing field of research called [Affective Computing \(AC\)](#) [103]. Following this trend, [Affective Gaming \(AG\)](#) seeks to incorporate emotion feedback into the video game domain.

The [Video Games \(VG\)](#) industry is now the biggest field of entertainment worldwide [33]. No electronic medium exploits [HCI](#) more, than [VG](#). [AG](#) offers great scope for naturalistic communications and interactions within the video game arena.

Relying heavily on [HCI](#), many [VG](#) attempt to stimulate emotions to captivate the

---

player. **VG** hold parallels to natural social intercommunication; both depending on a naturalistic emotive exchange. Typically, in **VG** communicating emotion or affect is a one way process, e.g. displaying emotive content towards the player. In life however, communicating emotion is a two way process. For **VG** to reach a level of communicative immersion that rivals that of real life, it needs to incorporate this two way emotive communication. However, **VG** are limited by the available technology that allows two way affective **HCI** to take place. What is missing are the sensory systems needed by the computer to access emotive behaviour presented by the player.

For **AG** success, **VG** need the sensory systems to detect and recognise changes in emotion and react to them accordingly. This would allow the game player's affective state to be incorporated into the game-decision mechanics. Thus, **VG** would make the leap from user emotive passivity into dynamic affective feedback, more akin to real life communication.

Affective acquisition can be categorised as either behavioural or physiological. The sensors, needed to acquire psychophysiological and behavioural data, have been around for some time. Both offer good insights into the affective state of the participant. Behavioural methods look or listen to how a participant is responding to the emotional stimuli. While, physiological methods detect the underlying-subconscious responses produced by the body to the same stimuli.

Using psychophysiological data within video games has been considered by commercial companies since the early 1980's [142]. The question of why such technologies were not adopted by consumers is less clear. We analyse what factors may have prohibited the early market adoption of such. In addition we offer a platform to enable affective acquisition systems to be utilised by a diverse market; making it open source.

### 1.1 Hypothesis

Acquiring utile affective data derived from psychophysiological phenomena has been well established in affective video game research. A number of commercial attempts to kick-start affective interactions within video games environments have been unsuccessful, which may have compounded the lack of investment in the area. This has led to a shortage of affective devices commercially available, particularly for researchers, independent game developers and consumers.

New rapid prototyping technologies offer the ability to build complex input systems capable of meeting this shortfall in affective devices. From our understanding, we are the first institution to explore the possibility of exploiting rapid prototyping technologies, to empower the open manufacture of affective acquisition devices, using simple inexpensive sensors for use in affective video games. The lack of available affective acquisition devices have no doubt hindered the progression of the field.

Therefore, the outline of our hypothesis is thus:

- Creating robust, simple and easy to use hardware, capable of capturing and streaming key psychophysiological signals, from an active video game player in real time, is possible using new on-board micro controllers and carefully placed sensors.

To examine our hypothesis we consider why psychophysiological input devices have not been adopted by mainstream vendors. We survey the history of affective gaming and its lack of impact since its initial inception over three decades ago. We consider the viability and functionality of three low cost physiological sensors. Coupled with rapid prototyping micro-controllers, and in combination with a classic video

game input device, we strive to prove their effectiveness at affect acquisition while playing an active video game.

We designed and built a bespoke mouse that is ergonomically designed to harvest the cleanest possible psychophysiological signals while in active use. The described design process, considered the ease of use as an important factor in the overall design. The device is called the Shark-fin mouse, owing to its unique heart rate sensor housing. User trials were performed using a custom video-game in order to ascertain whether usable psychophysiological data could be acquired from the device during active game-play.

Psychophysiological modes of affect detection may be good alternative solution compared to more natural behavioural modes, for video-games. The need for available psychophysiological sensor hardware, specific for video game playing, is identified. We exploit new printing technologies and rapid prototyping, and offer a solution to cater for the lack of affective hardware currently available. We performed and analysed data from an experiment that demonstrates psychophysiological data related to emotion can be recorded, from an active video game.

## 1.2 Chapter structure and hypotheses

### Chapter 2 Hypothesis

- Poor commercial investment combined with GPU logarithmic performance gains are the reasons why affective video games have not been fully exploited, over the past three decades.

Chapter 2 is a survey of the current commercial contributions to affective gaming and offers an insight into the trends that has steered the gaming industry thus far. It includes

descriptions of affective acquisition sensors and current academic contributors to the field.

### **Chapter 3 Hypothesis**

- Using on-board systems and carefully positioned sensors, it is possible to build an affective input device, which can offer robust psychophysiological signals, suitable for seamless active use.

In Chapter 3, we describe the process of developing, building and testing a functional affective mouse.

### **Chapter 4 Hypothesis**

- A simple video game, designed to stimulate small changes in emotion corresponding to game ‘events’, could stimulate detectable and useful psychophysiological data.

Chapter 4, covers the development of an affective video game.

### **Chapter 5 Hypothesis**

- Changes in a player’s emotion can be recognised from psychophysiological data using pattern recognition techniques, even when using crude data taken from an actively played affective video game.

Chapter 5 discusses the analysis of the retrieved data, using visual and various classifiers and ensembles.

The conclusion and future work is given in Chapter 6.



### 1.3 Contributions

This thesis offers the following contributions.

- We present a survey of the technological advancements of affective gaming, from a historical perspective. The survey details the wide array of affective input modalities and their merits and demerits for affective gaming. The outcomes of the survey, show why various affective gaming attempts may have been unsuccessful. It also highlights the motivation for affective gaming and supports the need for more affective input hardware to be developed.
- In response to this hardware shortfall, we researched, designed and developed an affective input device. The device was ergonomically designed for the best possible signals, while maintaining ease of use. We developed a novel design that integrates blood volume (heart beat) sensors into a mouse, using a unique front mounted cowl, named the Shark-Fin. The Shark-Fin assists in keeping the finger in the correct position and offers a darkened covering, to improve signal fidelity. We also described design features to maximise blood flow and avoid heat build-up.
- Our analysis utilised classification techniques that looked at the correlation between psychophysiological data and the game-state data. The results of these analysis established the utility of using affective data streams over traditional pre-emptive emotive definitions. Traditional ideas of what should invoke emotional changes may be less reliable, than interpretations from psychophysiological data. They also verified that the mouse was capable of producing useful data, when used in an active video game. Moreover, the results of our analysis demon-

strated that classifier ensembles out-performed traditional single classifiers in all of our trials, using psychophysiological data.

## 1.4 Publications

- Kuncheva L.I., Christy, T. Pierce, I and Mansoor, S.P. (2011). Multi-modal Biometric Emotion Recognition using Classifier Ensembles, Proc 24th International Conference on Industrial, Engineering & Other Applications of Applied Intelligent Systems (IEA-AEI), NY, Lecture Notes in Computer Science, LNCS 6703, 317-326.
- Christy T. and L.I. Kuncheva, (2013). A.M.B.E.R. Shark Fin: An unobtrusive affective mouse, Proc ACHI2013: The 6th International Conference in Computer-Human Interactions, Nice, France, 488-495
- Christy T. and L.I. Kuncheva, (2014) Technological advancements in affective gaming: A historical survey, GSTP Journal on Computing, 3(4), 32-41.
- Christy T. and L.I. Kuncheva, (2014) DIY Affective Gaming: A Practical Psychophysiological Acquisition Device, submitted to IEEE TAC.

# Chapter 2

## Advancements in Affective Gaming

### 2.1 Introduction

A computer is an electronic device that is programmatically controlled to perform an array of logical operations, which can solve a diverse array of problems. Its invention spurred the technological revolution and computers now dominate the world; such that their use is pervasive in every avenue of life.

One area that continues to separate human to human communication verses human to computer communication is the conveyance of emotion. For human to human this process is two way, but for human to computer it is one way; from computer to human. Emotion is a crucial component in human interactions, problem solving [97] and entertainment [103].

The role of emotion in human interactions was discovered nearly two millennia ago and has been documented scientifically for well over a century [25, 59]. However until 1997 [106], emotions were not taken as a serious consideration within the computational scientific community.

### 2.1.1 Affective Computing

Research by Picard et al, a professor in Massachusetts Institute of Technology (MIT), changed the view summarised above, and spurred a new field of study called [Affective Computing \(AC\)](#). The verb affect is taken from the word affectionate, meaning a mental state of emotion. [AC](#) considers emotion to be a vital component in [HCI](#), taking any emotional transmission (to and from a computer) to be an important and utile variable.

This field is growing rapidly and changing the landscape of [HCI](#). There are several common methods of detecting emotional expressions. Each fall into two broad categories, behavioural and physiological; discussed further in [2.2](#). Affective computing exploits the body's subtle and obvious disclosure of these outward expressions.

No area of the modern computer revolution utilises [HCI](#) greater than that of the computer video game paradigm. Video games have become the leading global entertainment industry, overtaking the movie industry on sales and revenue statistics [[33](#)]. Provoking profound emotions is deemed to be of vital importance in many video game genres [[100](#)].

### 2.1.2 Emotional States

In the last few decades, elaborate physiological sensors that require careful contact with the body have been developed to improve emotion detection [[22](#)]. Several systems have been created that investigate the useful properties of physiological data in a working environment [[115](#), [147](#), [105](#)]. Many of these systems limit the freedom people have come to expect when interfacing with a computer system. There is a debate over the accuracy of such systems for detecting and classifying states of emotion.

A big part of the problem is that emotions are as complex and unique as the people

who experience them [59, 105]. Labelling emotion states (such as happy, sad, angry, etc.) from physiological and behavioural data is still work in progress [17].

Russell [116] proposes the Valence-Arousal (VA) cognitive model of affect, extensively used for what is termed *dimensional approach* to emotion representation and recognition [48]. However, many argue that only arousal is perceptible from the physiological responses of the autonomic nervous systems [119]. Other studies have reported high classification of accuracy using valence in certain conditions[104]. The difficulty in using the VA scale for physiological signals is that context plays a significant role in determining a label for a given emotion state [16].

Valence is the measure of attraction or averseness to a given stimuli. One could be attracted to an object of disgust (being in awe), but feeling appalled or saddened by its presence, making the distinction of positive and negative emotion challenging. Considering an arousal model offers far greater scope in determining usable data from a highly contextual environment. An area that enables the great control over context, as well as environmental, visual and audible cues, is the interactive video game.

### 2.1.3 Ethical Perspective

Utilising personal data in relation to human physiology, as a form of computational input, raises new ethical issues. Such issues would concern the access, ownership, storage and analysis of physiological profiles, associated with individuals. For example, the sensors used to detect heart rate and peak amplitude (pressure) could highlight medical issues pertaining to an individuals heart condition. Without medical backing, could the data be considered valid health information? Does the system or administrators (without medical knowledge) of such a system have a right or duty to raise a

concern? Could raising a false concern cause undue stress to an individual. Does any group or organisation have permission to analyse individual medical conditions without specific consent? Could such information be used by industry (such as insurance) to monitor health? If so who would govern such use of personal data?

These types of scenarios and concerns will need to be fully explored as [AC](#) develops. However, our aim here is to highlight this new ethical perspective, and not to give any recommendations as to the correct ethical viewpoint.

### 2.1.4 Affective Gaming

[AG](#) is a relatively new field of research that exploits human emotion for the enhancement of player's experience during video game play. Interestingly, affective based video games have been considered commercially since 1982 [2].

Conventionally, a video game attempts to elicit player emotion by its story-lines, characters, video effects, music, game-play-rewards, etc. However, there is no precise means to assess if the expected emotion is being experienced. To be fully immersive, it is important to be able to detect a change in the player's emotional state as a result of the game play. There is no provision for assessing such changes within mainstream gaming practices. [AG](#) seeks to remedy this through the use of psychophysiological or behavioural sensors that read, interpret and respond to changes in a player's emotion in real time.

Basically, an [AG](#) system acquires emotion-related signals from sensor inputs, analyses the signals, and provides data to the game engine [54]. The game is subsequently altered taking into account the type and strength of the measured emotive data. Figure 2.1 shows a diagram of a real-time [AG](#) loop.

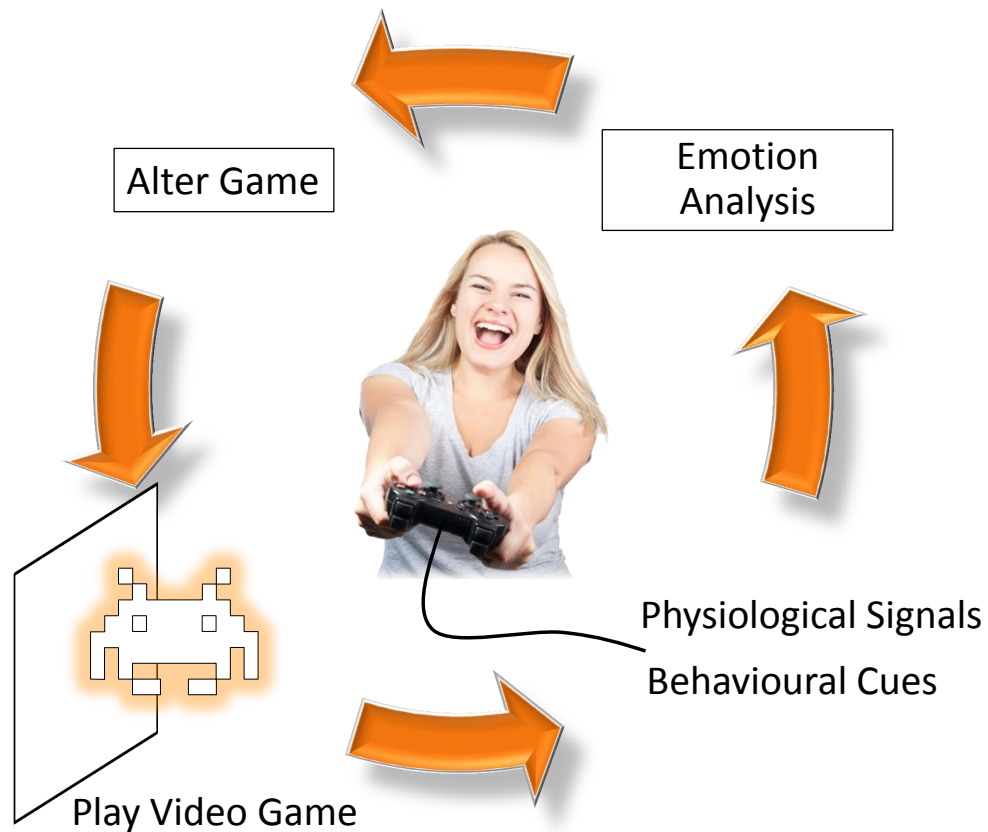

Figure 2.1: The real-time affective gaming (AG) loop.

To offer utility, a commercial AG system is expected to stream real-time emotive data, be robust, and most importantly be easy to use. The main criticism to experimental research in affective computing thus far has been that it is carried out in a heavily controlled environments, which limits its chances for practical applications. Affective gaming development has to move away from the confines of a laboratory and be deployed in normal environments [35, 105, 21]. In addition, the lack of available hardware is a limiting factor.

A particular challenge is designing a single all encompassing taxonomy of the field because it is comprised of several broad disciplines: physiology, psychology, electronic engineering and computer science. It should also be mentioned that results of

research into AG conducted in commercial settings are rarely published.

In this study, we survey the historical technological developments and research efforts that are attempting to bring practical AG to reality, including academic and commercial contributions to the field as a whole. The rest of the chapter is organised as follows. Section 2.2 summarises the difficulties in measuring and classifying emotion. We argue that affective gaming does not rely exclusively on the accuracy of emotion recognition. Any change of the emotional state of the player that is detected and reflected in the game can contribute to the player’s experience. Behavioural and physiological modalities for affective data acquisition are presented in Section 2.3. We put the emphasis on the wealth of physiological modalities as the preferred input for AG. Section 2.4 review *other-studies* that use physiological modalities in AG. Section 2.5.1 contains a historical perspective of the development of two of AG-related technologies: console platforms and video graphics. Finally, Section 2.6 concludes the chapter by listing the tasks and challenges set before modern AG.

## 2.2 Emotion as an input

Can we recognise and classify emotion? Emotion is notoriously difficult to quantify, measure or put into clear-cut categories [82]. The prevailing evidence from psychology and psychophysiology is that emotions do not naturally form distinct clusters in data spaces extracted from representational cues, but are rather facets of a continuum. The relationship between the physiological measurements and the emotional states they are supposed to identify is complex and ambivalent [35]. The list of difficulties faced by researchers in automatic emotion classification has been widely discussed in the literature [17, 35, 64]. It includes but is not limited to:



- We don't know what to measure.
- Emotions experienced by the subject may not correspond well to the stimuli.
- Different subjects may react with different emotions to the same stimulus.
- The presentation of emotion will differ between subjects and also at different time moments for the same subject.
- Emotion is not clear-cut and measurable, therefore there cannot be "ground truth" data.
- There is no agreed protocol for stimulating and measuring emotion.
- There is no agreed protocol for testing emotion classification systems.
- The classes of emotions are intricately related to one another.

A vast diversity of results have been reported in emotion recognition experiments [19, 75, 102]. Owing to the difficulties listed above, classification accuracy in identifying categorical emotions was found to vary considerably, spanning a range between 51% and 92% [96]. Along with the excitement, the literature contains cautious or even sceptical views [84]. It may be that endeavours to label emotion accurately across different subjects might be an impossible quest using today's technologies [106, 120, 21]. Employing interdisciplinary research effort has been strongly advocated [105, 64].

Video games are designed to entertain, and thus allow a leeway in the quest of recognising a specific emotion. The ultimate aim of an affective game is to make the player aware that the game recognises and interacts with their emotional state, throughout the course of the game. Occasional misclassification will not have a crucial impact to the player's enjoyment or satisfaction. Furthermore, whether an emotion is

experienced positively or negatively may not be significant. Recognising that there has been an alteration in the state of the players emotion, could be enough to satisfy a change in the game, thus improve the players affective immersion.

## 2.3 Affect acquisition

There are two distinct means of collecting affective data, namely behaviourally and physiologically. A variety of input modalities are used to gather affective cues from the player. Figure 2.2 shows a diagram of the major types of modalities in affective computing.

### 2.3.1 Behavioural

Behavioural methods of affect detection are naturalistic, in that they mimic how we innately detect tiny visual and communicative emotional cues. They focus on outward emotional gestures, postures, facial expressions and reactions, etc. Behavioural manifestations of emotion are somatic (corporeal), therefore can be acted and have been shown to differ pan-culturally [29]. Communicating outward emotional gestures towards a computer can feel unnatural. Research has shown that people dislike being recorded (Always on Kinect). Other behavioural cues such as speech modulation have shown success, but some participants have expressed discomfort at talking emotively to machines [62]. Although, intercepting voice communication between people speaking together online could overcome this. However, such a technique could raise ethical issues and limit the types of games that affective data could be used in. In addition, video data analysis can be computationally expensive.

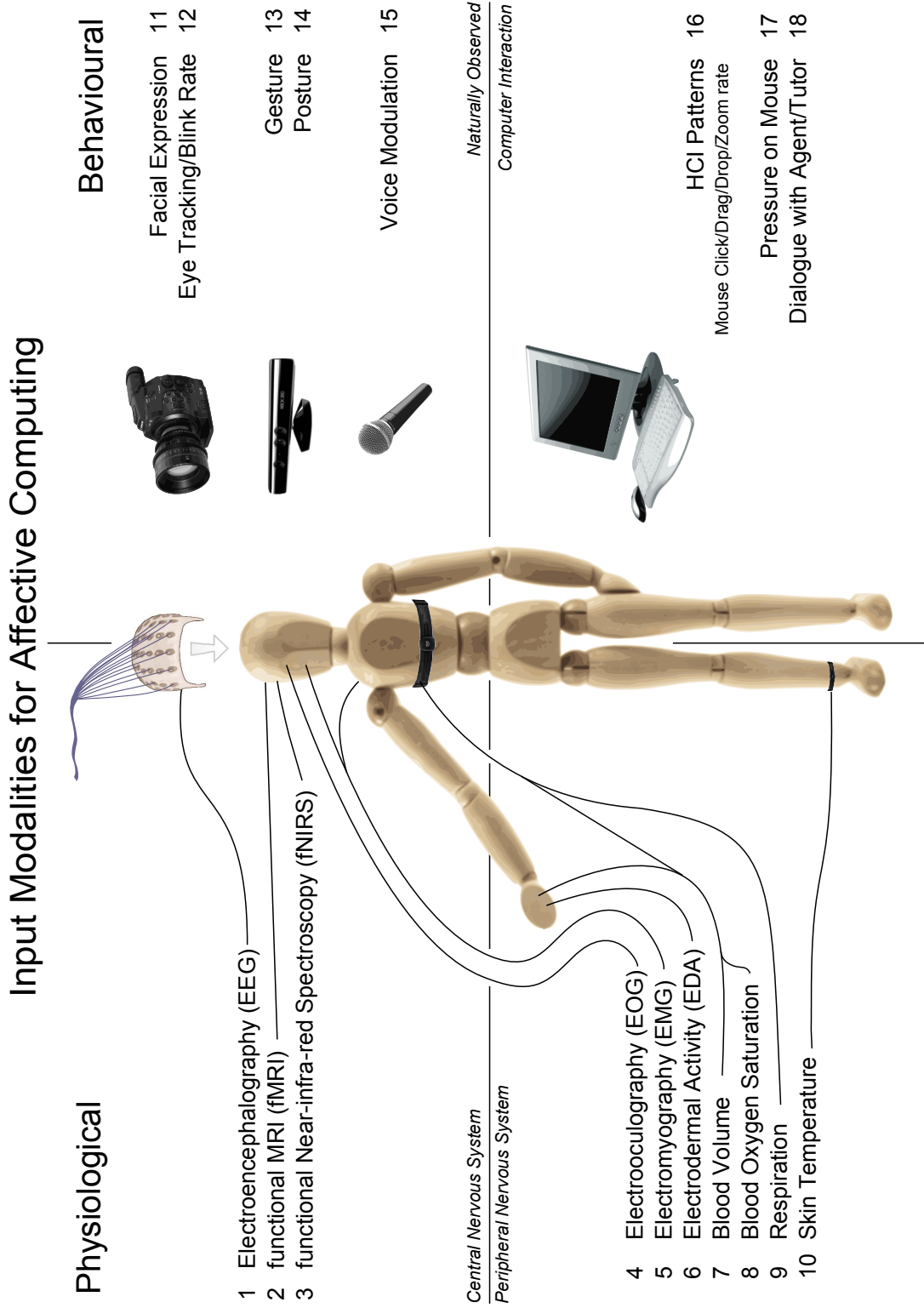

Figure 2.2: Input modality human connectivity comparison, showing physiological and behavioural divide.

Behavioural affect detection (BAD) modes can be described as methods of emotion capture that consider the outward expressive behaviour of a person, in relation to their emotive responses to any given stimuli. BAD is an instinctive approach and is often used in video game research and development [38]. Figure 2.2 (#11 – #15) lists the general types of naturally observed behavioural modes. While, Figure 2.2 (#16 – #18) lists the modes that are capturable through HCI.

When engaged in a communicative dialogue with a real person, it is normal to express facial emotions and emotive body gestures or body language, as a response to the message being conveyed. There are at least 100 documented facial expressions to concisely describe the emotion or mood of a person [95]. However, when faced with a video game display, such outward expressions of emotion are not expected from the active player. Spontaneous emotions may be expressed but the player will not be naturally compelled to react in the same way as in human to human interaction. In addition, (as mentioned) emotive facial expressions can be acted and have been found to differ pan-culturally

Emotion detection using cameras has been criticised for being inefficient, in that it requires a lot of processing power to sift through video data streams [36]. However, it should be noted that this was before the introduction of hardware visual analysis in systems such as the Microsoft Kinect, see Figure 2.2 (gesture #13 & posture #14). In addition, behavioural affect detection presents cultural, gender, and age differences, making behavioural analysis difficult [111].

Voice modulation is perceived as an important behavioural modality for detecting emotion in video games. This is a particularly useful method of analysing affect, during natural online player-to-player conversations. However, it has been observed that some players feel uncomfortable talking directly to a video game [61].

### 2.3.2 Physiological

Physiological expressions of emotion (psychophysiology) can be exploited to overcome some of the issues found in Behavioural emotion detection. Psychophysiological (PPG) reactions to emotive stimuli cannot be controlled easily, thus their use in Lie Detection. They work Pan-culturally, meaning they are not a learned behaviour. And moreover, they can be embedded into already adopted hardware input controllers.

Research has discovered that individual reactions are unique, such that different people will react to the same emotive stimuli differently [106]. However, physiological affect detection offers an insight into the unconscious projection of emotion, through signals produced as a consequence of the experience at hand, and presented through the nervous system. The two types of physiological modalities in Fig. 2.2 come from the central nervous system (CNS) and peripheral nervous system (PNS), respectively.

### 2.3.3 Nervous systems

The human body is controlled and maintained through a complex system of interconnected nerves, that govern the conscious and subconscious mechanisms of the working body.

Figure 2.3 depicts the basic nervous system pathways and their connectivity hierarchy. From the central nervous system (CNS) stems the peripheral nervous system (PNS). The Motor pathways in the PNS are further separated by the somatic (voluntary) and autonomic (involuntary) nervous systems. Further, the autonomic system is separated three ways into the sympathetic, parasympathetic and enteric nervous systems.

Although the technical workings of these systems far exceed the scope of this the-

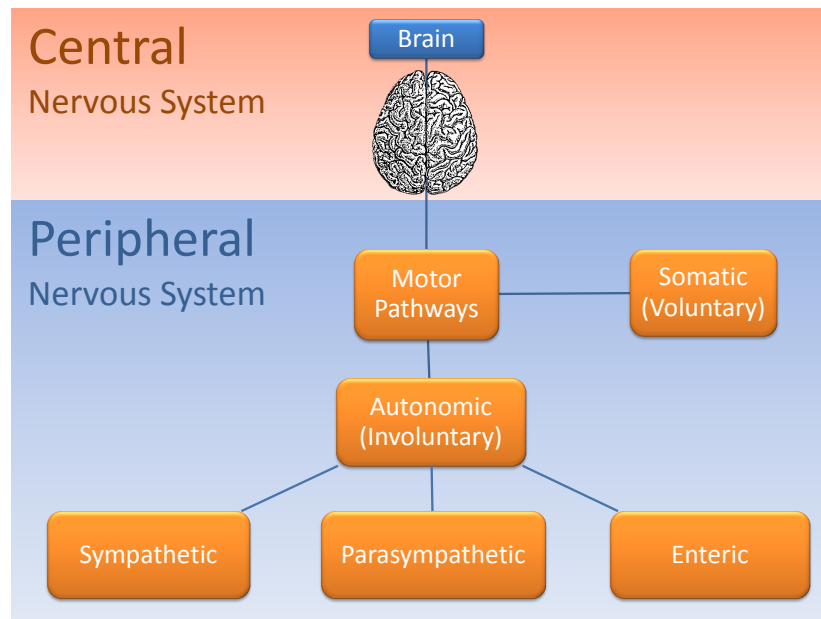

Figure 2.3: Nervous system pathways

sis, here we give a basic overview of each, and their general purpose.

- **Central** nervous system (CNS) acts like a router, consisting of the brain and spinal cord. The CNS is responsible for the part of the nervous system relating to the brain and spinal cord.
- **Peripheral** nervous system (PNS) relays information from the extremities (limbs and organs) to the brain. The PNS is divided into the somatic (SNS) and autonomic (ANS) nervous systems.
- **Somatic** nervous system (SNS) is part of the Peripheral Nervous System that deals with voluntary controls of the body, such as the skeletal system.
- **Autonomic** nervous system is a part of the peripheral nervous system that deals with the below consciousness control of the visceral functions; such as digestion, respiratory rates, sexual arousal, heart rate, etc.

- **Sympathetic** nervous system is responsible for mobilising the fight-or-flight response (fast).
- **Parasympathetic** nervous system works in harmony with the sympathetic nervous system to regulate the rest-and-digest system (slow).
- **Enteric** nervous system maintains the function of the gut (gastrointestinal) system.

Emotive data of brain-wave activity has been researched through various modes.

In the near future, it is unlikely that AG will benefit from technologies such as functional Magnetic Resonance Imaging (fMRI) or functional Near Infra-red Spectroscopy (fNIRS), due to both their size and cost, see Figure 2.2 (#2 & #3) respectively. The most accessible technology for neurophysiology is [Electroencephalography \(EEG\)](#), with numerous commercial systems entering the market, in addition to the professional systems employed for psychological research. [EEG](#) is an important technology in modern neuroscience. Compared to fMRI, [EEG](#) has a worse spatial resolution but a much better temporal resolution [42]. The electrical potentials related to emotion can be projected widely in an intricate pattern across the scalp, and can therefore overlap with potentials evoked by other activities. [EEG](#) has been utilised in the classification of emotions in various contexts [124, 132, 14, 67] and is progressively becoming a portable lightweight technology. Several commercially available [EEG](#) sets are available:

- OCZ – Neural Impulse Actuator (Nia) [98]
- Neurosky – Mindset [93]
- Neurosky – Mindwave [94]

- Emotiv – EPOC+ [32]

It is often assumed that the projections of positive and negative emotions in the left and right frontal lobes of the brain make these two emotions distinguishable by EEG. Practice has shown that the granularity of the information collected from these regions through EEG may be insufficient for detecting more complex emotions [14].

For AG the area of greatest interest is the involuntary autonomic functions of the nervous system. Being involuntary, the emotive signals emanating from the ANS are veritable. They form a true representation of the uncontrolled emotional state changes of the participant.

Psychophysiology (PPG) is the study of a combination of innate human physiological responses in relation to emotional or cognitive changes. The correlation between emotion and physiology is well founded [141, 144, 103, 146], and has been thoroughly explored throughout psychological studies [128]. Some of the most commonly used physiological inputs are listed below.

### 2.3.4 Physiological modalities

- EDA Fig. 2.2 (#6), also referred to as Galvanic Skin Response (GSR), Skin Conductance Rate (SCR) or Psycho Galvanic Reflex (PGR), measures the variance in electrical conductivity through the surface of the skin. EDA readings are effected through the sympathetic nervous system, making it a good indicator of stress and anxiety. EDA suffers from latency, with a delay of approximately one second for a response to be evoked, followed by approximately three seconds for the effect to dissipate. It is among the most basic and low cost physiological modalities available, and is widely used in physiological emotion recognition,



including video games [26, 3]. EDA is commonly read between two fingers on either hand, although is not limited to this area of the body [13]. Even though there is a delay, research has shown that EDA responds very well to changes in emotive states [4]. Moreover, even though there is a delay in the signal being invoked, there is evidence to support that EDA responses are produced prior to any emotive event occurring [22]. This suggests that participants pre-emptively react to events taking place on-screen. Therefore, EDA bodes well for adaptation into video-game controllers.

- **Photoplethysmography (PPG)** (blood volume) Fig. 2.2 (#7 – #8) is the measurement of blood entering and leaving a given part of the body. The measurable rhythmic variance in blood volume is directly related to the heart rate (pulse). The variance in heart rate is considered a good indicator of stress and anxiety [123]. Measuring blood volume also offers information relating to the strength of a heart beat. These measurements are seen in a change in the amplitude of the blood volume waveform signal. A higher amplitude in the blood volume waveform is also an indicator of stress, anxiety and health [23, 123].

As a sign of its pervasive popularity, heart rate input became the pivotal component of a television game-show, called *The Chair* [5]. In this show, contestants answered general knowledge questions and were expected to maintain a calm heart rate to win money. The sensing devices suitable for affective gaming come in the form of a clip, which uses optical technology to measure simultaneously heart rate and blood oxygenation [123].

- **Respiration** Fig. 2.2 (#9) Emotion can influence breathing rates [53, 12]. The measuring device could be a respiration belt or sensors embedded into clothing.

For example, a force feedback vest with embedded breathing rate sensors already features in the avid pro-gamers' arsenal [34]. However, mainstream applications could be hindered by utilising garments to acquire data.

- **Temperature** Fig. 2.2 (#10) Body temperature is affected by emotion, specifically joy, anger and sadness [88, 89], and has been used for emotion recognition in video games [137, 13]. Temperature sensors fall into two general types: contact and non-contact. Both types are sensitive to movement, which can introduce inaccuracies in the data collected. Movement is an important issue in the process of active video game play; hence, the positions of the sensors have to be chosen carefully.
- **Electromyography (EMG)** Fig.2.2 (#5) measures the electrical activity produced by muscle movement. Activity patterns in muscles such as orbicularis oculi (eye) and zygomaticus major (smile) are often used for affect detection. However across the populous (including nationalities), people differ widely in terms of how they facially display emotion[106, 120]. Besides, EMG sensors may need to be placed at various body locations (in particular on the face), which may compromise the player's comfort.

Table 2.1: Early period devices suitable for affective computing.

Year	Author	Acquired a patent for:
1928	Schrawzkopf & Wodtke [121]	An electrocardiograph.
1928	Hathaway [50]	A circuit design of an <b>EDA</b> device <i>Apparatus for measuring psychogalvanic responses</i>
1943	Raesler et al. [110]	<i>Psychogalvanometer</i> ; a fluid-aided <b>EDA</b> device.
1944	Milne et al. [87]	<i>Psychometer</i> ; an easy to use device.
1953	Koller [68]	<i>Cardio-Pneumo-Electrodermograph</i> ; an advance upon earlier machines.
1953	Holzer & Marko [52]	<i>Arrangement for recording variations in the electrical resistance in the human body.</i>
1954	Mathison [80]	<i>Electropsychometer or Bioelectronic instrument (v1)</i> ; a sponge-aided <b>EDA</b> device.
1955	Golseth & LeGrand [47]	<i>Electronic Diagnostic Instruments</i> ; a portable <b>EDA</b> device.
1956	Mathison [81]	<i>Electropsychometer or Bioelectronic instrument (v2)</i> ; a low cost <b>EDA</b> device.
1958	Douglas [27]	<i>Psychogalvanometer</i> ; <b>EDA</b> plus phonographic recorder.
1964	Ryan [117]	An improved Novelty (Toy) lie detector.
1965	Takagi [131]	An <b>EDA</b> device.
1967	Weidinger et al. [143]	A portable heart monitoring device.
1969	Tygart [138]	<i>System for FM transmission of cardiological data over telephone lines.</i>
1972	Burlyl R. Payne [101]	<i>Audible Psychogalvanometer (AP)</i> ; smaller and low-cost <b>EDA</b> device.

### 2.3.5 Sensors and devices

Table 2.1 shows a list of patents of early affect detection devices, up until the advent of the modern video game (in 1971). These systems formed the bedrock of modern PPG technologies. The table demonstrates that electronic devices capable of electronic capture of psychophysiological signals were developed more than 40 years before electronic video games were introduced. It raises the question as to why such technologies were not exploited by VG since that time? It then leads on to Table 2.7, which highlights the progression of the VG industry.

Sensors and devices for AG can be roughly grouped into three types.

- *Gold Standard sensors.* Hardware used in AG research has been borrowed from psychological research or commercial relaxation systems, such as the BioPac[10], IOM [145], etc. Commercial hardware for physiological acquisition is considered expensive and awkward to use [66]. Standard affect sensors give better results when they are held still. However, the devices can be regraded as a nuisance, being attached to the player's fingers, ear, etc. This makes them less suitable for active video game play.
- *Wearable sensors.* Wearable sensors implies "body worn", making long term physical contact with the body [106]. In 1997, Picard and Healey [106] introduced an affective wearable system that stored physiological data from Respiration, EDA, Blood Volume Pulse (BVP) and EMG, for later analysis. Picard's work would later become a beacon for affective computing research [51, 70, 13]. Sensors can be embedded into clothing, glasses, gloves, shoes, hats, helmets, jewellery, etc., making this an attractive avenue for AG. Wearable sensors are becoming more pervasive, with large companies such as Apple, Samsung, Sony

and Google investing into the field; Apple watch, Concept Dual-Shock-4, MindRDR respectively. Wearable systems could play a key role in profiling users behaviour throughout the day, enabling more concise recognition of temporal states of emotion.

- *Seamless contact sensors and devices.* The sensors in this group come into contact with the body for a limited time, for example through traditional interfaces such as mouse, game-pad and keyboard. To be considered seamless, the user should not be aware of any interaction with the sensor. For example, EDA could be measured from electrodes embedded into the hand-grip of a console controller or on a mouse. A comprehensive study on research devices of this type is provided by Reynolds [115], examples of which are
  - Sentograph – measures and visualises user’s touch along a two-dimensional space.
  - Touch Phone & touch mouse – measures grip strength.
  - Sentic Mouse – senses directional input.
  - Squeekee – measures click pressure.
  - IBM Emotion Mouse – gathers temperature, EDA and somatic movement.

Even though the core technology for physiological signal capture is mature and well proven, hardware specifically tailored for affective gaming is still not widely available.

Affective video game input must be comfortable and intuitive to use. If a sensor impedes the enjoyment and competitive edge that video game players expect, it is less likely to be adopted. AG would benefit best from seamless contact sensors. The

hardware needs to move from expensive laboratory equipment towards reliable and affordable consumer devices [35, 105, 21]. Affective sensors can be incorporated into already adopted video game controllers [78, 4, 13, 21]. Valve Software and Sony have both implied that **EDA** and **Heart Rate (HR)** could soon be incorporated into standard controllers. Producing bespoke low cost hardware for AG is feasible [13, 21, 31], for example, by using recently released rapid prototyping platforms [43, 1] and 3D printing.

It is proposed that this type of rapid prototyping should shape the newly forming landscape of AG.

## 2.4 Commercial Affective Gaming

1982 saw the iconic video game and console developer Atari made the announcement of a new form of computer game interface, called the Atari Mindlink. The Mindlink *suggested* the use of brain waves to interact with a new breed of upcoming games, see Figure 2.4. The Mindlink was to be used as an input device in lieu of a standard joystick controller. The device used **EMG** to detect movements on the muscles of the forehead. It was abandoned during Atari's redistribution in 1983 [142], and never saw its commercial debut. The device was never commercially released.

An **EDA** device, called the Mantra Mouse, was introduced in 1984. The Mantra Mouse sent **EDA** signal responses to a PC's audio port, enabling the signal to interact with bespoke software. Figure 2.5 (a) shows the Mantra Mouse. The device was aimed at teaching relaxation techniques. The device is still commercially available today [135].

By 1997, an arcade (coin-op) machine that utilised heart rate and **EDA** signals was



Figure 2.4: Atari Mindlink flyer, image courtesy of [www.atarimuseum.com](http://www.atarimuseum.com).



Figure 2.5: Calmpute Mantra EDA input device (a) and CalmPute CalmPrix affective game (b).

released in Japan. The accompanied game was called *Tokimeki Memorial Oshiete Your Heart* and is described in section 2.5.2. In 1998, Nintendo utilised a heart rate monitor to alter the difficulty and bonus delivery of a competitive version of Tetris, described more in section 2.5.2. These games are discussed in further in section 2.5.2.

## 2.5 Utilising Affective Data

By 2001, academic research into AG officially began [115, 9, 107]. Table 2.2 lists the research contributions made within the field of AG since 2001, including the physiological sensors and video games used. Many sensors and sensor permutations have been tested, along with several game genres.

The current methodologies used to utilise affective data can be categorised in to two areas; threshold and emotion identification. The former uses the raw signals, taken for various sensors, and determines a combination of thresholds to perform various changes to the game mechanics, as seen in Tables 2.3 & 2.4. The later involves attempting to determine the emotion of a player using physiological methods, such as the valence and arousal space. Various pattern recognition classifiers have been used, such as SVM (see section 5.3, in chapter 5), etc.

As indicated in 2.1.2, we believe determining valence is highly individual and wholly contextually based. Therefore, to process and use meaningful affective data, arousal and game context must be considered in combination with either physiological or behavioural data. Far more research will be required to establish affective ground truths in this field. Which feeds into the purpose of developing our system. To enable such research to take place, available hardware capable of delivering affective data is required.



Tables 2.3 and 2.4 detail game variations in response to changes in physiological data, published by Dekker & Champion [26]. In this example, visual and audible effects are introduced to the game when particular EDA and HR signal threshold combinations are met. Tijs et al. [136] use 7 physiological parameters to guide the speed of Pacman (Table 2.5).

To illustrate the developmental potential of the physiological input modalities, we collated the accessible publications explicitly devoted to affective gaming, and noted which ones address the engineering of bespoke psychophysiological hardware. Figure 2.6 gives a bar chart of the distribution of the publications over the years. The papers whose main focus are psychophysiological sensors and devices are marked in a lighter shade.

New Timeline Image

Even though the publication numbers are not high, an emerging trend could be identified. Affective input devices are beginning to make their way to the centre stage of affective gaming.

Judging by the achievements and the potential of using physiological modalities in AG, the future is likely to see smarter and more sophisticated implementations on progressively smaller, more robust, reliable and noise-free devices. Wearable sensors are also likely to become more pervasive.

### 2.5.1 Generations of console platforms

The introduction of the electronic computer heralded the beginning of a new era [24]. No sooner had the computer become affordable to the masses; video games became an arising staple of popular entertainment [108]. Interactivity plays a pivotal role of

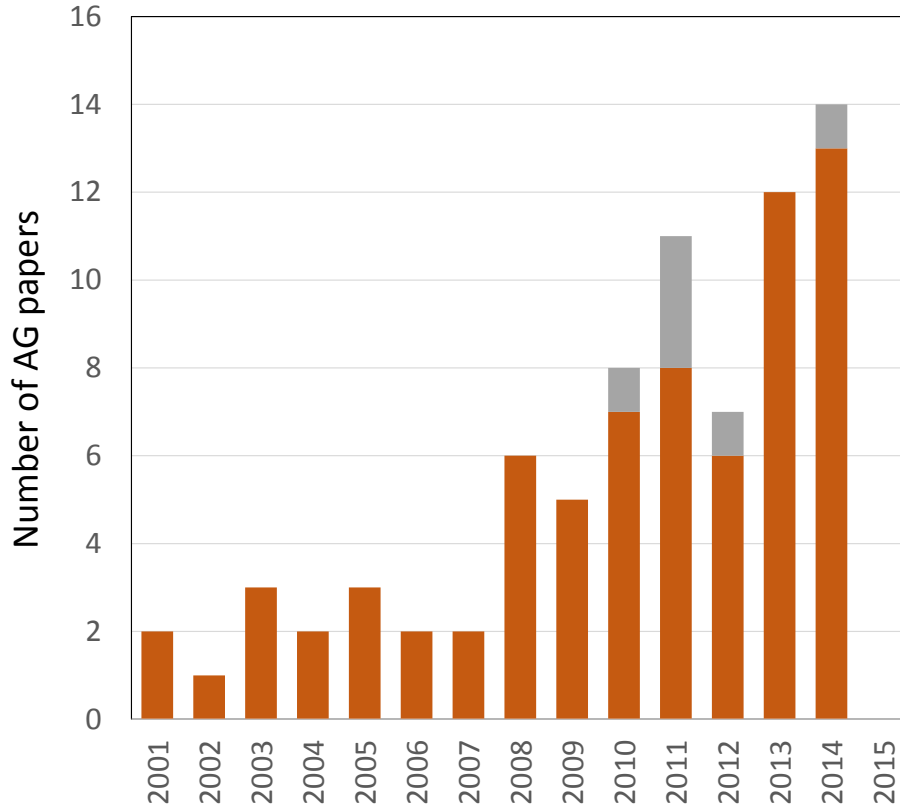

Figure 2.6: Time-line view of AG research publications. Publications addressing bespoke psychophysiological hardware are shown in a lighter shade.

video games. Typically, video games allow the player to interact with the virtual environment an interface device such as joysticks, joy-pads, keyboards, mice, trackballs, cameras, touch-screens, etc. Video game consoles have become a dominant symbol of the mainstream video game market. Several attempts have been made to introduce AG to the mainstream [142, 40, 41, 69, 6]. The companies involved manufactured the necessary hardware and software to foster the use of affect in video games. However, none of the systems were successful in the long term. Below we take a closer look at the developmental context and the possible reasons for the delayed progress.

Figure 2.7 shows a time-line representing the introduction and commercial duration

of 8 video console generations. Each generation is presented as a horizontal coloured bar. Key commercial contributions are indicated with colours relative to the console generation they were released on.

Earlier video game machines, such as *Galaxy Game* and *Spacewar* are acknowledged, but do not form part of the public commercially available video game systems.

### 2.5.2 Commercial Affective Video Games

The first commercial video game, available to the paying public, was an arcade machine called *Computer Space*, which was released in 1971. In the same year, the first video game console, called the Magnavox Odyssey, was released depicted in the timeline in Fig. 2.7. This heralded the birth of the home video game and the industry as a whole.

## 2.5 Utilising Affective Data

Table 2.2: Affective gaming modalities and the current academic contributors in order of year.

Year	Modalities	Game
1999 [114]	EDA	AffQuake (Quake II)
2001 [9]	EDA	Racing Dragon
2002 [120]	HR, EDA, EMG, video	Puzzle
2003 [46]	HR	Action based
2003 [130]	Game pad pressure	Space Invaders
2005 [111]	ECG, ICG, HR, HS, EDA, EMG Temperature, questionnaire	Pong
2005 [118]	User control knobs	Generic
2005 [8]	EDA, EMG	Cards (Skip Bo)
2006 [83]	HR, EDA	Treasure Hunt
2006 [112]	HR, EDA, facial EMG	Monkey Ball 2
2007 [77]	EDA, ECG, HR	NHL 2003
2007 [26]	EDA, HR	HalfLife2
2008 [109]	EEG	Break-Out
2008 [60]	Time, eye movement	Half Life
2008 [20]	HR, EOG, EDA, EEG, respiration, Temperature	Tetris
2008 [62]	Audio (vocal cues)	Half Life Mod
2008 [113]	HR, EDA, facial EMG	Monkey Ball 2 & James Bond 007
2008 [136]	HR, EDA, respiration	Pacman
2009 [91]	EDA, EMG	HalfLife2 Mod
2009 [140]	Control tilt, pressure	Need4Speed
2009 [76]	EDA, HR, EMG, Temperature	Pong & anagrams
2009 [28]	EDA, HR	Prey, Doom3, Bioshock
2010 [137]	EDA	Racing
2010 [72]	EDA, Respiration	Emoshooter (FPS)
2011 [13]	EDA, HR, pressure, temperature, gyroscope	Racing Car
2011 [4]	(Use) EDA, (Tried) HR, eye movement, Portal2, EEG, pupil dilation, EOG, posture, gesture,voice, face expression, respiration	Left4Dead2 Alien Swarm
2013 [21]	EDA, HR, Temperature	Custom game
2014 [31]	EDA, Pulse	Pong
2014 [7]	EDA, HR, PPG and Temperature	Death Unknown

Table 2.3: Dekker & Champion visual effects and physiological threshold conditions; used in the modified video game *Half Life 2*.

Emotion	Game Change	Criteria*
Comatose	Sound (heart beat), new enemy or boss	$HR + EDA < 0.8$ or $< 0.4$ below avg
Bored	Black & White	$HR < 0.8 - \text{avg}$
Calm	Shader (White filter)	$HR > \times 2 + \text{avg}$
Worried	Shader (Red filter)	$HR > \text{avg} \times 2$
Panic	Shader (Bright red filter) + FOV = 130	$HR > \times 3$ above avg
Berserk	Shader (Red screen)	$HR > \times 3.5$ above avg

Table 2.4: Dekker & Champion conditions applied to psychophysiological threshold criteria in the video game *Half Life 2*.

Condition	Criteria*
Stealth	$EDA 0.5 \gg 0.7$
Invisible	$HR < 0.5$ and $EDA < 0.5$
Weapon damage	$HR \& EDA \times 40$
Speed	$HR$
Sound volume	$EDA^2 \times 0.8$
Bullet time (Slow motion)	$EDA > \text{cal} \times 3$
Shake	$HR > 3.8$ above avg

Table 2.5: Effects of game speed of *Pacman*, based on psychophysiological data input

<b>Physiological features*</b>	<b>condition identified (action)</b>
Mean <b>SCL</b>	slow (speed up)
Number of <b>SCR</b>	slow (speed up)
Mean <b>HR</b>	slow (speed up)
Mean respiratory	slow (speed up)
<b>CORR</b>	fast (slow down)
<b>ZYG</b>	fast (slow down)
Key pressure	slow (speed up) & fast (slow down) & normal (nothing)

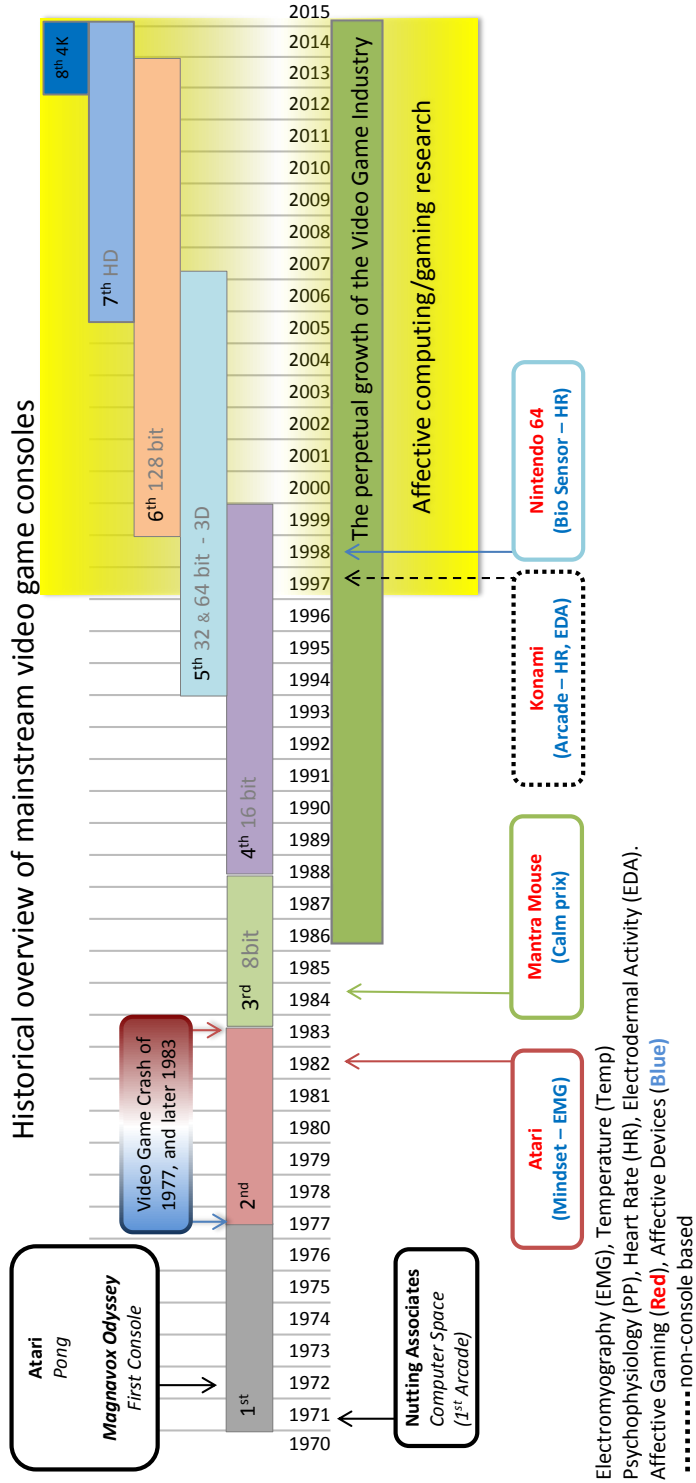

Figure 2.7: Video game console time-line representing the introduction and commercial duration of each console generation, shown in segments. Key commercial contributions are indicated pinpointing the year of release. Given in brackets are the names of the relevant companies.

In 1984 CalmPrix was introduced with a psychophysiological system called CalmPute. CalmPrix was a car racing video game that used EDA signals to alter the speed of the racing car. It used a commercial EDA sensor called the Mantra Mouse or GSR2 [40] as an input device. The CalmPrix video game was meant to teach a relaxation technique, using an extremely primitive racing car game (even for the time). CalmPrix would have been pitted against games such as the highly successful *Mario Brothers* (1983) [55], *Return of the Jedi* and the genre creating *Elite* (1984) [56]. A screen mock-up of the video game Calm Prix is seen in Figure 2.5 (b). Commercially, it didn't stand a chance.

1997 saw the release of *Tokimeki memorial oshiete your heart*, which was a provocative and alluring arcade game. The game was only available as an arcade machine in Japan, which limited its global success. It was a Manga-comic style cartoon dating game, far flung from the popular games of the day, such as *Herc's Adventure*, *Backyard Baseball* and *Claw* [57]. It encouraged players to express physiological affect (love) towards cartoon characters (Manga art), which was measured by EDA and HR sensors. The fact that it was a publicly visible arcade game requiring emotion, may have been a factor in its lack of commercial longevity.

*Tetris 64* was released on the Nintendo 64 in 1998. It used HR taken from a clip attached to a player's ear to control the speed of the falling shapes. The game allowed up to four players to compete on the same screen, making it possible to alter the outcome of the competition using emotional feedback. The game concept was rather old and the requirement of an ear clip could have handicapped the game's success. Although Tetris remains a famously popular relic, it was competing against games such as *Half Life*, *Crash Bandicoot*, *Sonic Adventures*, etc. [58]. In addition, it was reported that Nintendo was experiencing issues with its latest console. Among these were expensive



cartridges, poor graphical rendering and a complex programming interface [134].

Another physiological device that had been considered was the Wii Vitality. However, this device was not released due to speculation that it would not prove commercially successful [63]. It is worth noting the gradual decline in the Wii sales, which may have (again) formed a strong part in that decision.

### 2.5.3 Graphical advancements

Immersion is important for emotional experiences within video game environments [15, 60]. The illusion of immersion and interaction with surroundings, materials and substances in modern video games cannot be achieved without the giant steps in video graphic hardware and software. Graphic technology and video games evolved synchronously. They developed from primitive monochrome pixelated-blocks being controlled on a cathode ray tube (CRT) to advanced visually realistic, fully immersive, simulated environments, presented on ultra high definition (4K & 8K) organic light emitting diode (OLED) liquid crystal displays (LCD). The quality of displays continuing to improve. Detailing advanced graphical techniques, such as particle systems, billboards, shadow-maps, etc., is beyond the scope of this thesis. However, it is noted that advanced graphical hardware and software techniques have formed an enormous part of this growth. Here we are interested in the exponential technological growth in video graphics performance and its relationship with video games and AG.

Companies such as Intel, Array Technologies Industry (ATI) and nVidia made vast efforts in the graphic rendering technology arena, through competitive video card releases. An advanced programming interface (API) called OpenGL [125] (Open Graphics Library) was introduced in 1992. It offered a single graphical programming inter-

face across all popular technologies and platforms, thereby speeding up game development. Notably, nVidia released the Graphical Processing Unit (GPU) in 1999.

Mega ( $1000^2$ ) Texels (MT) are defined as the number of texture elements graphic hardware processors can manipulate per iteration. Figure 2.8 demonstrates the exponential growth of MT graphics hardware performance since 1997. In 1997, the maximum MT expected from a 3D rendering graphic processor was  $\log_{10}(100)$ , which grew exponentially to  $\log_{10}(1875000)$  by mid-2013 [126].

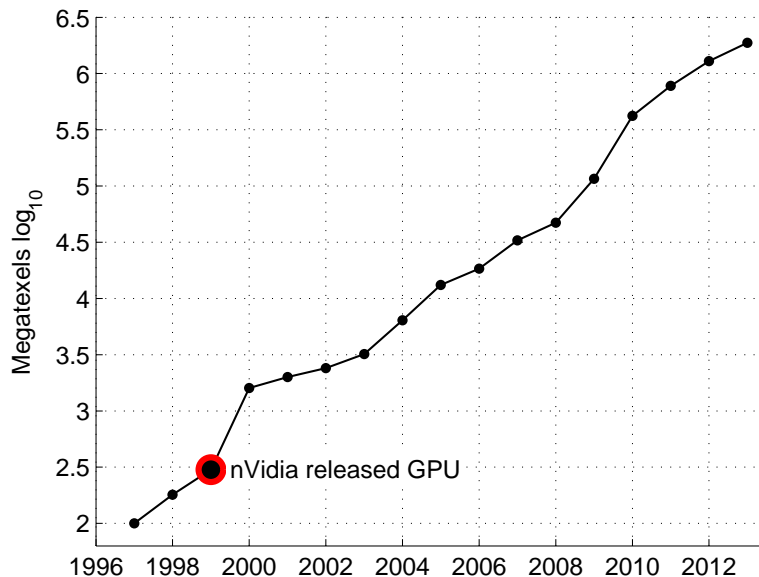

Figure 2.8: Graphic card technology advancement since 1997 beginning in 1997 at 100 mega-texels (MT) and growing exponentially to 1,875,000 MT by mid-2013. The vertical axis is  $\log_{10}(y)$ , where  $y$  represents maximum MT per year.

It is suggested that graphical advancements could soon reach a plateau. High-end video game systems are now capable of animating real-time graphic renderings that are becoming visually close to that of real life video footage. In addition, video graphic displays have pixels that are so minute, they cannot be discriminated individually by

the human eye, with a pixel density greater than 300 pixels per inch.

This signifies that the quality of graphics and graphical performance will soon be indistinguishable from reality. As the visual component of video games reaches a peak, more emphasis on player's interaction and immersion is expected. Games are now appealing to a more sophisticated audience, with the average age of the frequent game purchaser being 35 [33]. This calls for exploring new avenues for simulating intelligence and affect manipulation.

### 2.5.4 Commercial Interests

Commercial video game publishers are rumoured to be considering psychophysiological hardware, as part of their next generation of video game consoles [127]. Currently, the gaming mouse company Mionix [90], are raising a Kickstarter campaign for their R&D department, MIONIXLABS [65]. The mouse will feature two sensors; HR and EDA. It is expected to be released in September 2015 at a retail price of €129.99.

Thelmiclabs have released an EMG armband, called the MYO [133]. The MYO currently offers detection of 5 specific gestures; wave left, wave right, spread fingers, fist, and thumb-to-pinky. Although this does not offer affect detection, theoretically it could be programmed to detect emotive based gestures.

Technology capable of both behavioural and physiological affect detection are beginning to emerge. This may herald the birth of real commercial investment into AG.

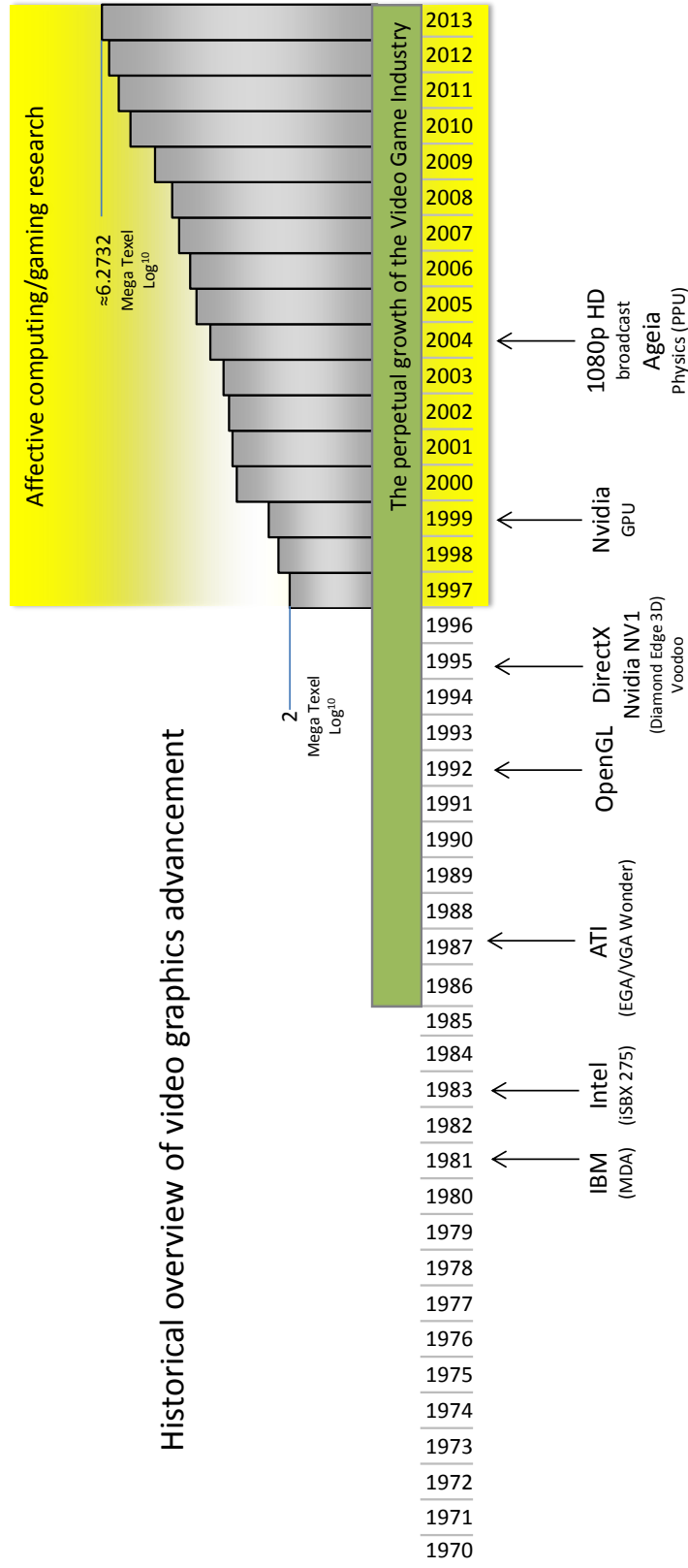

Figure 2.9: Graphics advancement timeline, highlighting a historical overview of video graphic card advancements, depicting significant graphics hardware and software contributions.

## 2.6 Summary

We hypothesised that ‘Poor commercial investment combined with GPU logarithmic performance gains are the reasons why affective video games have not been fully exploited, over the past three decades’.

We surmise that previous attempts at AG (e.g. Atari, Marta Mouse, Konami and Nintendo), may have lacked proper investment and each attempt was introduced at the wrong time or for the wrong reasons. For example Atari may have been attempting to revive an ailing company, but collapsed before they introduced their new AG product. The Mantra Mouse (Calm Prix) was aimed at relaxation techniques and offered an extremely primitive game, thus underwhelming their initial launch. Konami released a seductive/erotic arcade game that was presented in public spaces. As successful as they were, Nintendo may have been attempting to overcome the reported difficulties they were experiencing with the Nintendo64, but lost ground to the new 128bit systems that were later released. While there was scope for graphical and performance improvements, graphics enhancements remained the driving force for advancement in the video game arena. This left no space for affective interaction to impress the audience (gamers). We believe that our hypothesis stands true.

As graphics advancements are reaching a plateau, game developers are having to look at new methods to outshine the competition. This will no doubt move towards greater immersion. To fully exploit immersive human to computer interactions, emotions will play a vital role.

The general consensus is that using the player’s affective state to manipulate the video game adds to the enjoyment and immersion experienced. AG will play an important part in the future of video game interaction. The tasks remaining for modern

AG can be summarised as follows

1. Bring together expertise from the various fields that AG draws upon: psychology, physiology, computer science and engineering.
2. Create unobtrusive, robust and accurate devices for inputting physiological signals such as [EDA](#) and [HR](#) among many.
3. Develop state-of-the-art methodologies for reliable emotion recognition, as well as algorithms for detecting changes in the player's emotional state.
4. Move AG out of laboratories and into the developer's hands. A step in this direction would be the creation of an open affect - application programming interface (OA-API) for affect acquisition. When no affect acquisition hardware device is present, the interface would emulate the required emotive techniques necessary using software. This would enable the developer to code the game for affective video games with or without hardware-specific knowledge.

We speculate that video graphic advancements are heading towards a plateau, which will likely shift the game development focus towards greater intelligent and affective based interactivity. Such a shift is expected to open up commercial perspectives for AG, further. However, the bridge to achieving commercial AG is having affective input devices available to both developer and consumer. Thus far, this bridge is only being considered by large commercial companies, which limits the potential growth of AG.

The future of AG will rely on initiatives in hardware, to enable the development of new affective software. To cater for this need, we present a blue print for producing an affective acquisition device, suitable for affective gaming.

# Chapter 3

## Building Shark-Fin

This chapter outlines the construction of the Shark-Fin mouse and its preceding prototypes, describing the hardware and sensors used.

There are three points that need to be considered when building a physiological-sensor-equipped input device. The first, is that the sensors need to deliver readable physiological data. Second, the device is ergonomically shaped to safeguard the highest sensor fidelity. And third, the device continues to work as an input, maintaining its functionality and comfort.

### 3.1 Sensors

Any device that can respond to a signal or stimulus, particularly in relation human physiological changes, can be considered an affective sensor. We looked at the merit and demerits of the most widely used affective sensors, in affective video game research. Taking both sensitivity and practicality into account, we selected three sensors that would offer the optimum affective data, with the least amount of interference to

the user, when fitted to an input device. We selected electrodermal activity, photoplethysmography and temperature.

### 3.1.1 Electrodermal activity

**EDA** electrodes are used for their sensitivity to physiological changes in the dermal layer of the skin [128]. Skin resistance changes in-line with psychophysiological responses of a participant to emotion stimuli. As the body responds to external stimuli, tiny variations in skin secretions take place, as part of the body's natural autonomic nervous response system. These changes alter the resistivity of the skins dermal layer. The skin forms resistance between the two electrode contacts and acts as a bridge for the electrical current. The resistance is measured through a low direct current (DC), in this case 5-volts passing through the skin. These fluctuation in resistivity form the bedrock of affective **EDA** analysis.

### 3.1.2 Photoplethysmography

There are three commonplace modes of extracting heart rate data from the body; electric impedance, transmission and reflective.

We opted to use a transmission mode, over electric impedance and reflective modes of **PPG** for two reasons. First, being electrically based, electric impedance-plethysmography, may have interfered with the voltage from the **EDA** and vice versa. Second, modular reflective mode **PPG** sensors were not commercially available, at the time of building. The benefit of using reflective mode **PPG** sensors is discussed by Shelley & Shelley [123]. Both transmission and reflective mode **PPG** offer a greater insight into the physiology of a participant, by determining the signal waveform amplitude, among



other physiological responses [123].

Radiated infra-red light (IR-LED) is beamed through the skin, directly into the light detector (phototransistor).

The sensors are housed in an arched shaped covering, centred on the nose of the mouse, as shown in Figure 3.8 (Phototransistor & IR-LED). The user's middle finger sits in between the two components, blocking the path of the radiated IR light. As the volume of blood changes in the user's finger, (synchronous with a pulse) the light that is able to pass through the finger alters respectively. This change in light signal is detected by the phototransistor. Because it represents blood volume, the signal show both heart rate and the height of the peak waveform, both recognised stress level indicators [123]. The signal is amplified and smoothed using a simple circuit shown in Figure B.1 [86], before being converted to a digital signal by the FEZ mini, see Figure 3.8 (Amplification and smoothing PCB). A typical heart rate signal taken from the Photoplethysmograph is shown in Figure 3.16: Pulse.

### 3.1.3 Temperature

The final prototype added temperature to the BVP and EDA sensors. A pre-built infra-red thermometer printed circuit board (PCB) was used, for simplicity. The thermometer uses a MLX90614 infra-red Thermometer sensor attached to an ATmega328 Arduino based evaluation board [85].

An IR thermometer was used as it offers accurate non contact measurement of temperature. This deters thermal heat built up by allowing the focal point (on the palm) to be kept reasonably ventilated. Thermal ventilation was also a factor for choosing an open design of the mouse housing, see section 3.3. The IR thermometer is powered di-

rectly through the FEZ mini using 3.3 volts DC. The system sends a temperature signal in Fahrenheit to the FEZ mini using a UART (Universal Asynchronous Receiver/Transmitter) TX protocol, at a baud rate of 38400Bd. The sensor is seated under the casing of the upper mouse enclosure and reads the temperature of the lower palm, through a circular aperture, as seen in Figure 3.8 (Upper mouse enclosure). A typical skin temperature fluctuation line diagram can be seen in Figure 3.16: Temperature.

A mouse was selected, as it forms (along with the keyboard) the backbone of general HCI and its use necessitates continual hand contact. Psychophysiological sensitive mice have been considered before [115]. However, we believe that the technology needed to convert and transfer the captured data was not available during the earlier attempts. Such devices were the Arduino, which was released in 2005 and the FEZ (used here) which was released in 2010. In addition the process of moulding a bespoke shape for the inputs casing was so easily possible. Previous attempts had to adopt technically challenging methods of prototype construction. Prior, creating such complex prototype systems would have been prohibitively more expensive. Such rapid prototyping circuit technologies are continually improving.

### 3.1.4 Final System

The EDA, and PPG signals are processed through a simple circuit, before being sent to the analogue to digital converter (FEZ-mini). The Thermometer signal is sent directly to the FEZ, through its evaluation board TX/RX protocol system.

## 3.2 Hardware

The following section describes the hardware used in both the early and the final prototypes. The hardware demonstrates the simplicity of the system.

### 3.2.1 Early Prototype

We constructed a basic proof-of-concept affect acquisition prototype, using off the shelf, electronic components. Initially, we wanted to determine that detectable affective data could be extracted from crude hardware and sensors.

We selected the psychophysiological sensors based on their use in previous affective gaming research, and considering which would be feasible to be adapted inside a video-game controller.

For this system, we chose two sensors; a pair of electrodes for measuring [EDA](#) and a blood volume [PPG](#) sensor.

For the [EDA](#), an extremely simple sensor was constructed, using an electronic bread-board to hold two pieces of exposed wire as electrode points. The tin electrodes measured 1mm thick, 10mm in length. We powered the simple [EDA](#) sensor circuit using the 5 volt direct current (DC) supplied from a new prototyping board called the FEZ Domino. A 5-volt DC was used to be in-line with previous studies. The overall circuit voltage was lowered using a 100k resistor in a parallel circuit, to keep the signal within the 3.3-volt input range of the FEZ, as seen in Appendix B, Figure [B.2](#). This lowered the entire signal waveform but maintained the [EDA](#) fluctuation detail. The sensor can be seen in Figure [3.1](#).

The Pulse Rate Monitor circuit utilises a [PPG](#) blood volume detection system. We used a Maplin (N56FL) Pulse Rate Monitor kit [[79](#)], see Figure [3.3](#) (a). However, the

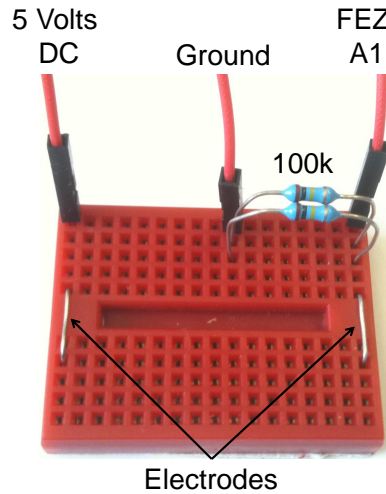

Figure 3.1: Electrodermal electrode placement

original N56FL circuit was designed to generate an audible beep when a peak in blood flow volume was detected. We redirected the audible beep's electrical signal to the FEZ Domino's analogue input pins.

The PPG sensors are constructed of two parts:

- A light source; an infra-red light emitting diode (IR-LED)
- A light detector; a phototransistor.

They required a structure to accommodate the infra-red light emitting diode (IR-LED) and a phototransistor. To create a structure, we fashioned a hub from the top of a standard two litre drink bottle, see Figure 3.2 (a) and (b). The hub was lined with paper to keep it dark and stop the light from reflecting.

The components we chose to interface the sensors to a computer were a TTL-232R-3V3-PCB [39] USB to serial converter, Figure 3.3 (b) and a FEZ Domino [30] analogue to digital converter, Figure 3.3 (c).

The TTL USB to serial converter, called a TTL-232R-3V3-PCB[39] allows a USB

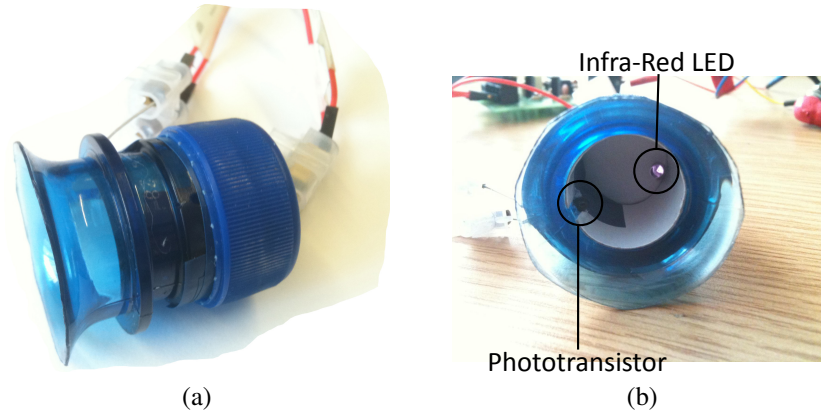

Figure 3.2: Bottle-top blood volume sensor casing and assembly, depicting bottle-top view (a) and paper lined Infra-Red LED, and phototransistor placement (b).

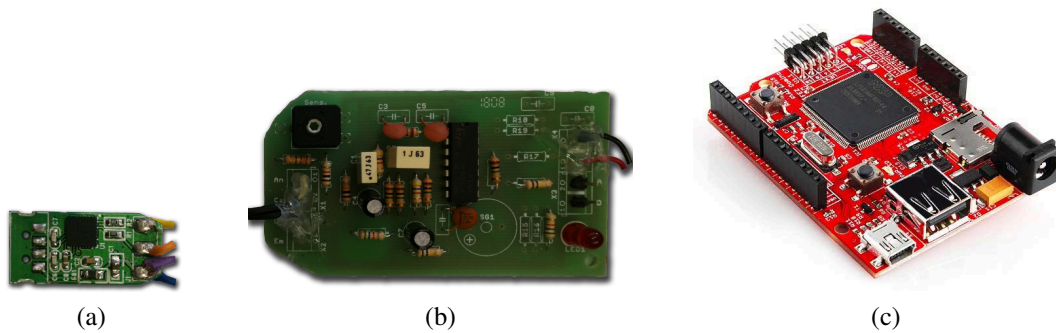

Figure 3.3: TTL USB to serial converter interface (a), Blood volume photoplethysmograph hobby kit (b), and a FEZ Domino electronic prototyping platform (c).

port to be accessed like a serial port, see Figure 3.8: (TTL). This simplifies the process of accessing the streaming data. Because, most programming languages (including Matlab) have native Serial Port access libraries. The TTL device's outer sheath was stripped to remove the USB type A plug connector. After this, the TTL measured just 24.9mm x 11.85mm x 1.6mm.

The data from the body's psychophysiological responses need to be converted from a fluctuating analogue electrical current into digital integer values. Therefore, an analogue to digital converter was needed. We opted for the FEZ, by GHI Electronics [44].

The FEZ acts as an analogue to digital converter. It's a micro-controller module that allows several analogue electrical signals to be read and converted into digital outputs simultaneously. In our case, it read-in electrical [EDA](#) and Pulse signals and returned an array of digital integer values to a computer in real time.

It is controlled by a 72mhz, 32 bit ARM (ARM7 LPC2387) processor which runs Microsoft .NET Micro Framework. It is powered by 3.3 volts DC, taken directly from the USB port. C# is used to program the module. The FEZ is relatively small, having the dimensions of 4.8cm x 2.8cm (1.88" x 1.10") and 11.34g (0.4oz) in weight. The serial Universal Asynchronous Receiver/Transmitter (UART) protocol was used to communicate between the FEZ and a standard PC

The data was organised into a *string* array and transmitted via Universal Asynchronous Receiver/Transmitter (UART) TX channel. MATLAB was used to receive and process the physiological data.

### 3.2.2 Experiment

The prototype (Figure 3.4) was used in an project experiment, led by Professor L.I.Kuncheva *et al* [74], in combination with a commercial [EEG](#) headset called the Mindset [93], as part of a wider project named A.M.B.E.R. (Advanced Multimodal Biometric Emotion Recognition).

The project attempted to discern positive and negative emotions expressed by the participant, in relation to hearing pleasant and unpleasant audio.

The experiment involved presenting auditory stimuli to the subject, while recording their emotive response, as they were wearing a [EEG](#) headset and touching the [EDA](#) sensor. The stimuli were selected so as to provoke states of relaxation (positive emo-

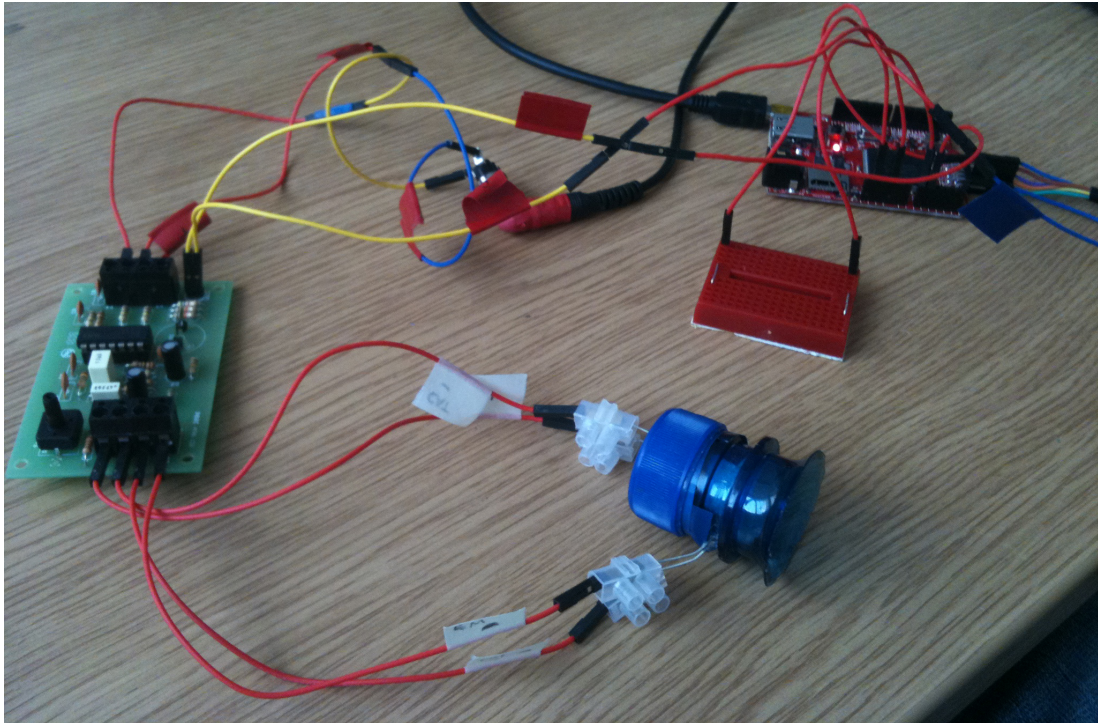

Figure 3.4: First Proof of concept prototype using low cost.

tion) or irritation (negative emotion). The positive audio stimuli were taken from an Apple iPhone application called Sleep Machine. The composition was a combination of wind, sea waves and sounds referred to as Reflection (a mixture of slow violins tinkling bells and oboes); this combination was considered by the subject to be the most relaxing. The negative audio stimuli were musical tracks taken from pop music, which the subject strongly disliked. The three biometric signals were recorded for 60 seconds for each of the 20 runs: 10 runs each of positive and negative stimuli respectively. The collected data was prepared, filtered and labelled, then passed through a variety of classifiers, as listed in Table 3.1.

Table 3.1: Classifiers and classifier ensembles used with the AMBER data.

<b>Single classifiers</b>	
1nn	Nearest neighbour
DT	Decision tree
RT	Random tree
NB	Naive Bayes
LOG	Logistic classifier
MLP	Multi-layer perceptron
SVM-L	Support vector machines with linear kernel
SVM-R	Support vector machines with Radial basis function (RBF) kernel
<b>Ensembles</b>	
BAG	Bagging
RAF	Random Forest
ADA	AdaBoost.M1
LB	LogitBoost
RS	Random Subspace
ROF	Rotation Forest

### 3.2.3 Interim Results

Table 3.2 shows the correct classification (in %) for all methods and data sets. The highest accuracy for each data set is highlighted as a frame box, and the second highest is underlined. All highest accuracies are achieved by the ensemble methods. The individual classifiers reach only one of the second highest accuracies while the ensemble methods hold the remaining 7 second highest scores. This result shows the advantage of using the classifier ensembles compared to using single classifiers. A series of pilot experiments revealed that none of the modalities alone were as accurate as the combination.

The results validated that there was utility in using such a basic system for extracting psychophysiological signals. We also took into account the effects of wearability and comfort, as researched by Bonarini *et al* [13]. It was deemed that the EEG Mindset



Table 3.2: Classification accuracy from the 10-fold cross-validation

Method	Data sets and number of instances							
	3s 400	4s 300	5s 240	6s 200	10s 120	12s 100	15s 80	20s 60
1nn	62.84	64.89	63.44	62.04	61.11	60.87	56.48	59.93
DT	64.16	58.57	67.37	65.92	58.49	62.78	<u>69.96</u>	58.93
RT	60.02	63.02	61.9	62.63	57.11	66.66	66.75	57.10
NB	64.69	63.81	64.45	64.48	65.02	67.82	65.43	61.07
LOG	62.04	60.37	62.59	63.27	59.26	59.16	57.59	57.53
MLP	62.46	59.37	63.28	63.36	63.43	64.22	57.05	58.47
SVM-L	62.09	61.41	63.52	62.38	62.32	59.13	58.70	56.83
SVM-R	50.81	51.16	50.56	50.52	50.18	51.19	51.66	51.33
BAG	<u>65.56</u>	<u>65.62</u>	68.25	67.09	<u>67.37</u>	68.79	66.46	<u>64.37</u>
RAF	64.51	64.65	66.08	65.27	65.86	<u>69.58</u>	67.29	61.57
ADA	63.41	62.21	<u>70.00</u>	67.59	61.07	66.28	<u>73.80</u>	<u>63.30</u>
LB	65.34	62.92	<u>68.78</u>	<u>68.05</u>	62.04	64.02	68.27	60.70
RS	64.96	64.78	66.25	<u>68.21</u>	64.61	67.43	68.95	61.77
ROF	<u>66.90</u>	<u>65.41</u>	66.86	67.23	<u>67.36</u>	<u>69.30</u>	65.46	62.27

device was intrusive, uncomfortable and impractical for a VG input device. Therefore, the EEG device was omitted from the next phase of experiments. The next step was to assess if the device was capable of functioning under normal working conditions. Therefore, it had to be incorporated into an input device.

Our initial

### 3.2.4 Final hardware

The psychophysiological sensors had to be located *inside* the input device. This was to ensure that all amplification, filtration and digitisation of the signals were processed as closely together as possible. Short connection cables lowered cable noise caused by mouse movement, which was exacerbated by amplification. The hardware for the final prototype had to be revised to accommodate a smaller overall spatial volume.

To ensure the hardware would fit inside a small container, the blood volume and EDA circuits were placed on one bespoke circuit board, see Figure 3.5.

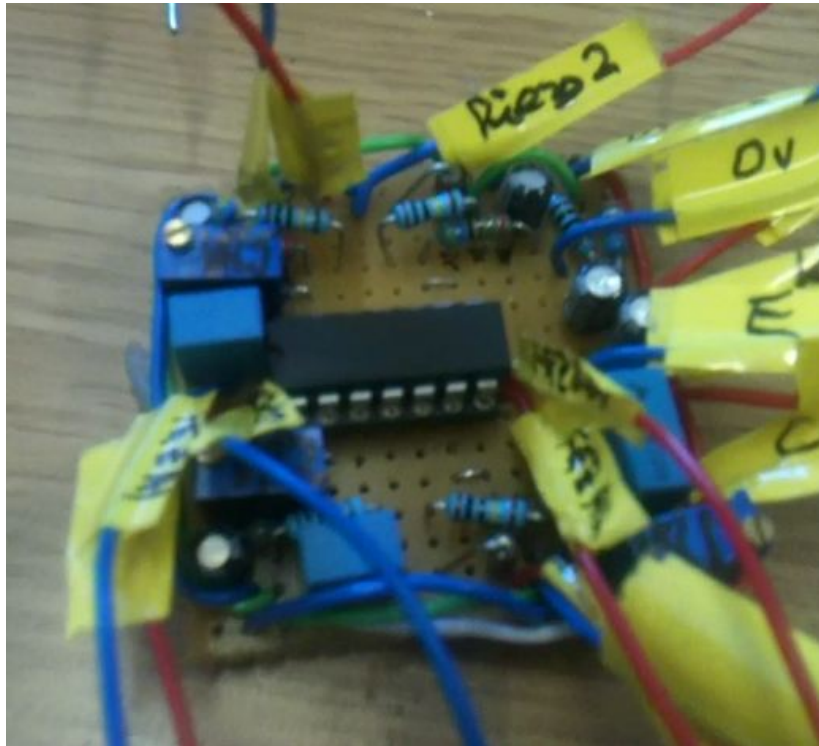

Figure 3.5: Custom circuit, fitted with EDA and Blood Volume circuits on one board. Built by Dr. Aled Williams, Bangor University, by modifying the original Maplin (N56FL) Pulse Rate Monitor kit to return the pulsed waveform.

The final prototype consisted of three different sensors (EDA, BV and Temperature) interconnected with six individual circuit components (IR Thermometer, Amplification and smoothing, FEZ mini, TTL USB to Serial Converter Mouse PCB and a USB hub), as seen in Figure 3.8.

A Temperature sensor was added to the array of sensors, because fluctuations in periphery body temperature is considered a good indicator of stress and anxiety [111, 20, 76, 13].

We selected an IR Thermometer evaluation board, utilising a MLX90614 IR Ther-

mometer, see Figure 3.2.4. The MLX90614 IR Thermometer evaluation board cost around £14 (2012).

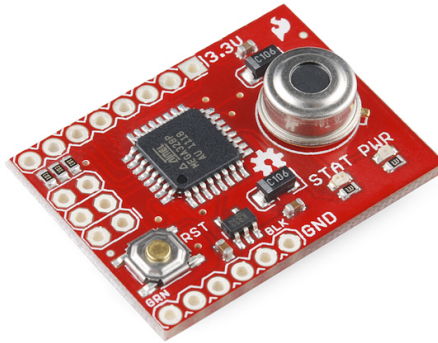

Figure 3.6: MLX90614 IR Thermometer evaluation board transmits IR detected temperature to TX UART port in Fahrenheit.

The thermometer measures temperature in the range of  $-4$  to  $248$  °F ( $-20$  to  $120$  °C), sensitive to approximately  $0.14$  °C. This board allowed the participant's body temperature to be measured without making direct contact to the skin. This meant that we avoided thermal heat build-up, expected using contact thermometers. The FEZ's UART port was programmed to transmit data at a baud rate of 38400 bps, to coincide with that of the MLX90614 thermometer. The code used can be seen in Appendix A.

A FEZ Mini was used, instead of the FEZ Domino because the FEZ Mini offered identical performance but on a much smaller PCB, see Figure 3.7. Apart from size, the main difference between the two was that the Mini required soldering in lieu of connector pins found on the Domino. For reference, the term FEZ will be used when discussing both FEZ mini and FEZ Domino, as needed throughout this thesis. The FEZ mini retailed at approximately £30 (2012). The total cost of the component used in this prototype, including the manufacture of a bespoke case (£35), in 2012 was

approximately £100 (USD\$148).

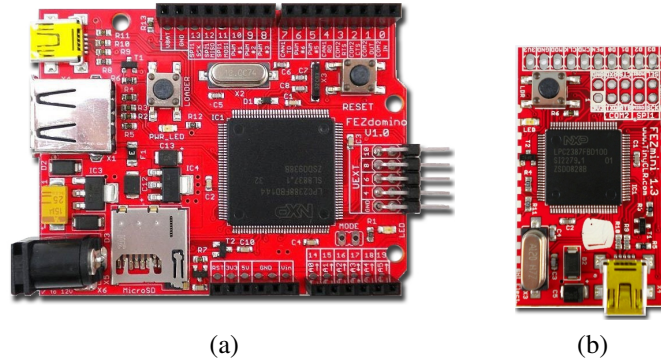

Figure 3.7: Approximate size comparison of FEZ Domino (a), used in the first prototype and a FEZ mini (b), used in the final Shark-Fin mouse.

Pressure sensors were also considered, seen labelled (piezo) in Figure 3.5, but they caused excessive signal interference during testing and evaluation.

For the final system, the EDA circuit was powered by 3.3-volts DC, taken directly from the FEZ. The EDA circuit sends the signal to the FEZ analogue input (pin A1), using a 1M(ohms) resistor in parallel between the FEZ and the earth (-V) connections.

For this prototype, the electrodes were constructed of two 1cm<sup>2</sup> brass plates, approximately 3mm in thickness. Brass electrodes were used as a low cost alternative to the more sensitive but expensive materials (such as Silver/Silver Chloride). Brass was used because of its resistance to corrosion. The larger surface area offered increased signal robustness. Brass has a higher International Annealed Copper Standards (IACS) value than Tin [11]; Tin was successfully used in our first prototype. IACS is a measure of the conductivity of alloys in relation to that of copper.

The photoplethysmograph data-signal is low powered and noisy, thus requires processing prior to transmitting to the FEZ. First the signal is amplified, using a typical operational amplifier chip powered by 5-volts DC. The amplification increases the noise and causes the signal waveform to become jagged, therefore smoothing is done with a

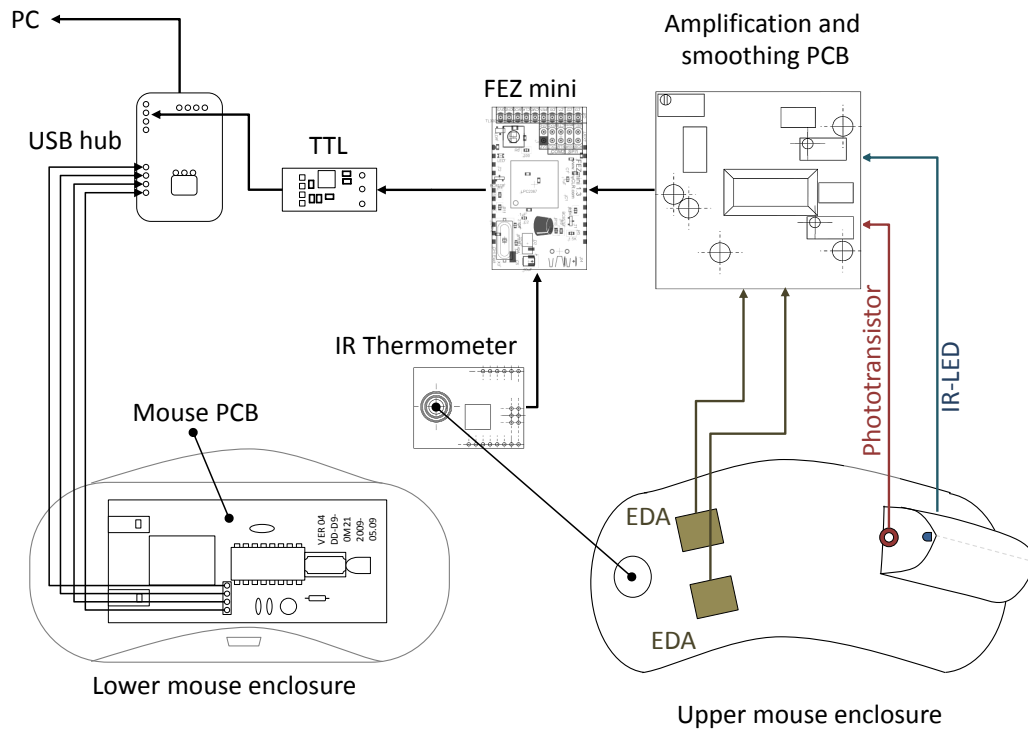

Figure 3.8: SharkFin mouse system diagram

capacitor. The circuit is seen in Appendix B.

### 3.3 Ergonomic Design (Shark Fin)

In this section, the construction of the final prototype is detailed, showcasing the use of new technologies (2011) and the ergonomic considerations that were necessary to gain the best possible signals from the finished device.

**Sensor positioning** The first task was to decide where the best location for each sensor should be. The sensors needed to function well and be unobtrusive. In addition, the complete system was also expected to be intuitive and easy to use, without needing

### 3.3 Ergonomic Design (Shark Fin)

---

straps or gels.

Several placement options were considered for the sensors that would not impede the user. In addition, To support mixed-handedness (ie left and right handed users), placing the sensors symmetrically would offer greater usability.

**Photoplethysmograph:** For the photoplethysmograph (PPG) we needed to use a location that offered a strong blood flow volume. Several locations have been used, including the ear, the forehead, the fingers, etc. [122, 13]. We chose a finger as the fingers represent the most natural method for human interaction.

Because the thumb and little finger work to grip the mouse, the index finger, middle finger and ring finger were selected as suitable options.

To maintain mixed-handed design, we opted to use the middle finger. In addition, the index finger and ring finger are often (not always) used for mouse clicking.

**Electrodermal Activity:** EDA sensors have previously been placed on the buttons of a mouse [115]. Because of the clicking function of the mouse buttons, this placement area was discounted due to it causing excessive motion artefacts. Therefore, the EDA sensor electrodes were placed on the back of the mouse case, where the palm of the hand naturally rests and makes constant contact with the palm, see Figure 3.9.

**Thermometer:** The thermometer sensor was positioned such that it took advantage of the same fixed palm location, used for the EDA. To try and reduce thermal heat build-up, the sides of the mouse casing were kept open; thus allowing heat ventilation.

**Shark Fin:** To support the photoplethysmograph (transmission mode) sensors, a structure was needed to hold both LED and phototransistor in place. Two positions

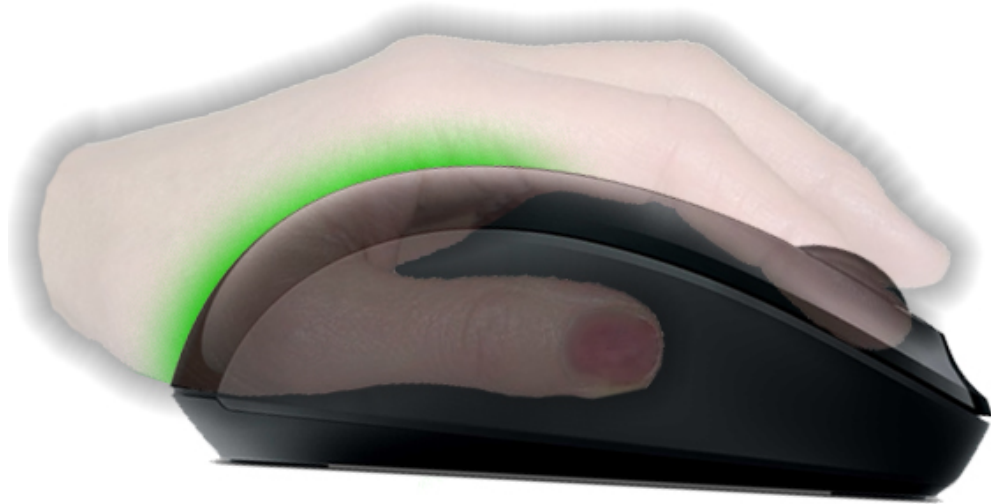

Figure 3.9: Point of continuous contact between hand and mouse highlighted green.

where considered for the photoplethysmograph sensors, see Figure 3.10 (a) and (b); (a) with a vertical sensor arrangement, housed in a covered hub and (b) using a horizontal sensor arrangement.

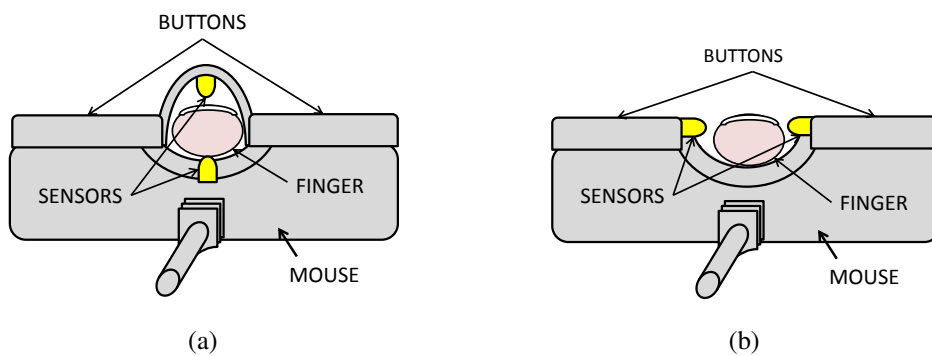

Figure 3.10: Front view of mouse enclosure depicting two possible positions for simetrical PPG sensor placement.

Option (a) was selected because the underlying sensors would not impede the movement of the mouse buttons and the enclosure provided a dark shade, which improved the PPG sensitivity to heart signals. In addition, the hub structure assisted in

### 3.3 Ergonomic Design (Shark Fin)

---

holding the finger still, improving the signal clarity further. A arched-housing (hub) was designed and situated centrally between the left and right mouse button. Figure 3.11 shows the early prototype casing. Owing of its profile, the hub was named the *Shark-Fin*.



Figure 3.11: Early Shark-Fin prototype casing; (a) before attaching sensors and (b) with EDA and PPG sensors included.

The first prototype and the new design shape highlighted some issues that needed to be overcome.

**Movement Artefacts:** It was clear that cable movement caused severe sensor signal noise. The longer the span of cables between the sensors and the analogue to digital converter (digitiser or digitisation), the greater the problem. This was particularly noticeable when there was movement of the sensors.

Therefore the first consideration was to reduce the amount of movement that was available between the sensors and the signal digitisation. The obvious solution was to place the sensors as close to the digitiser as possible. This meant that the digitisation and sensors had to be located on the input device itself.

Once the sensors' analogue signals were digitally converted, the issue of *cable* noise was eliminated.



### 3.3 Ergonomic Design (Shark Fin)

---

**Signal quality:** When the sensor was attached to a standard mouse an issue was seen when we tried to read a pulse (using the photoplethysmograph) from the users middle finger. When the users wrist rested on the mouse pad or table, as is customary for most people when using a mouse, the peak-length of the blood flow waveform was reduced by around 75%. This implied that the blood flow to the middle finger was significantly compressed when the hand was placed on a typical mouse. Therefore, it was important to alter the shape of the mouse, such that the wrist was raised up from the resting position. This involved testing different mouse shapes, that lifted up the wrist and maintained comfort when used.

We began by moulding a clay model of a mouse and testing it on five participants with different hand sizes, to asses user comfort, see Figure 3.12.

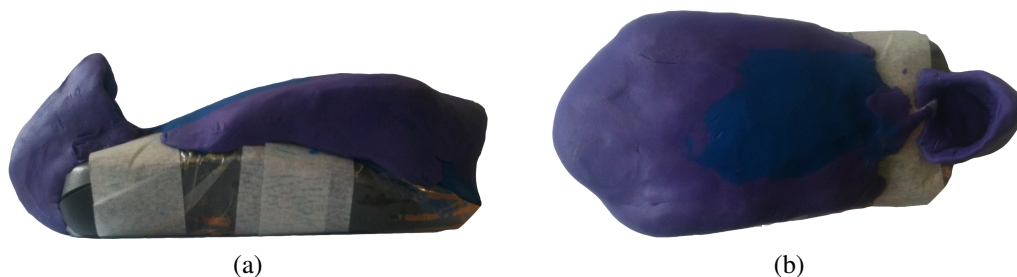

Figure 3.12: Clay model prototyping, assessing user comfort and ensuring casing lifted wrist to support strong blood flow to fingers.

The final shape was then digitally modelled using CAD software and printed in 3D using a rapid prototyping 3D-printer, see Figure 3.13.

The base structure of the new mouse was carefully designed to duplicate the internal housing structure of the doner mouse, to ensure that the doner mouse circuitry fit perfectly in its new home. The scroll wheel was relocated from its centre position to either the right or left side of the enclosure, depending on the needs of the user.

Each sensor component was incorporated into the new enclosure. The temperature

### 3.3 Ergonomic Design (Shark Fin)

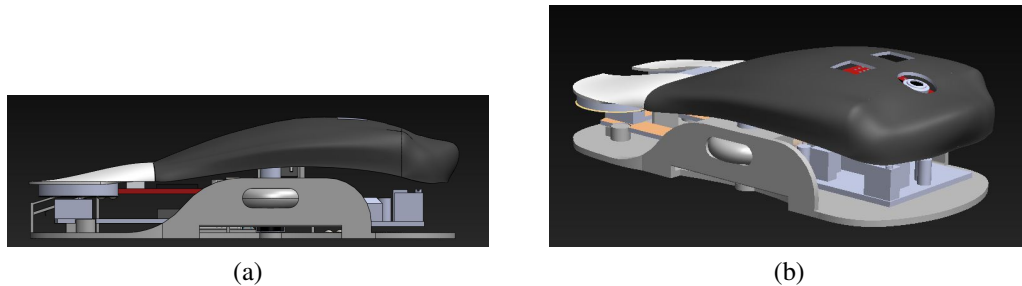

Figure 3.13: CAD drawings of mouse structure, incorporating all internal components. Each component were modelled accurately to ensure all the components fit perfectly together.

and [EDA](#) sensors were attached to the upper enclosure, as seen in [Figure 3.14](#) (a). The IR sensor of the thermometer was positioned to point through a circular window (hole). The remaining amplification and smoothing PCB, FEZ mini, Mouse PCB, USB hub, TTL and photoplethysmograph sensors were added to the lower mouse enclosure, see [Figure 3.14](#) (b).

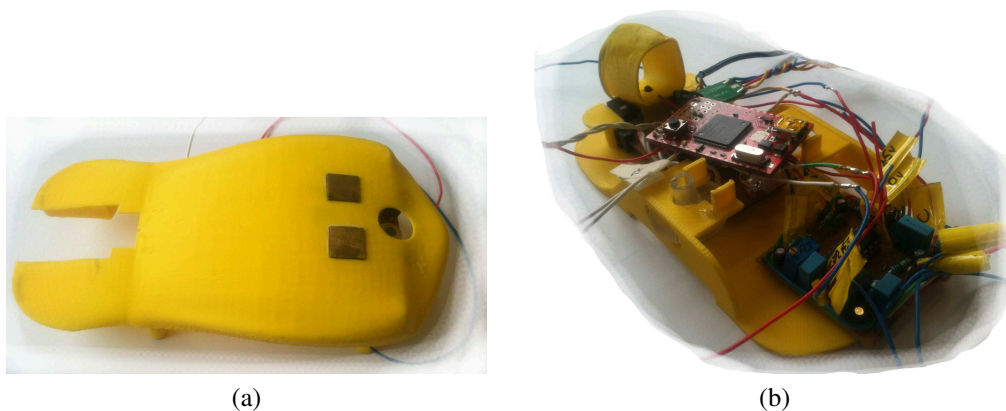

Figure 3.14: Upper (a) and lower (b) parts of the 'affective' mouse device, with sensors and electronic components attached.

The two parts were then joined together, depicted in [Figure 3.15](#).

**Data Transmission:** Each of the sensors electrical signals were digitally converted in the FEZ. Then the data was concatenated into a string data-type packet, eg “[1 2 3

### 3.3 Ergonomic Design (Shark Fin)

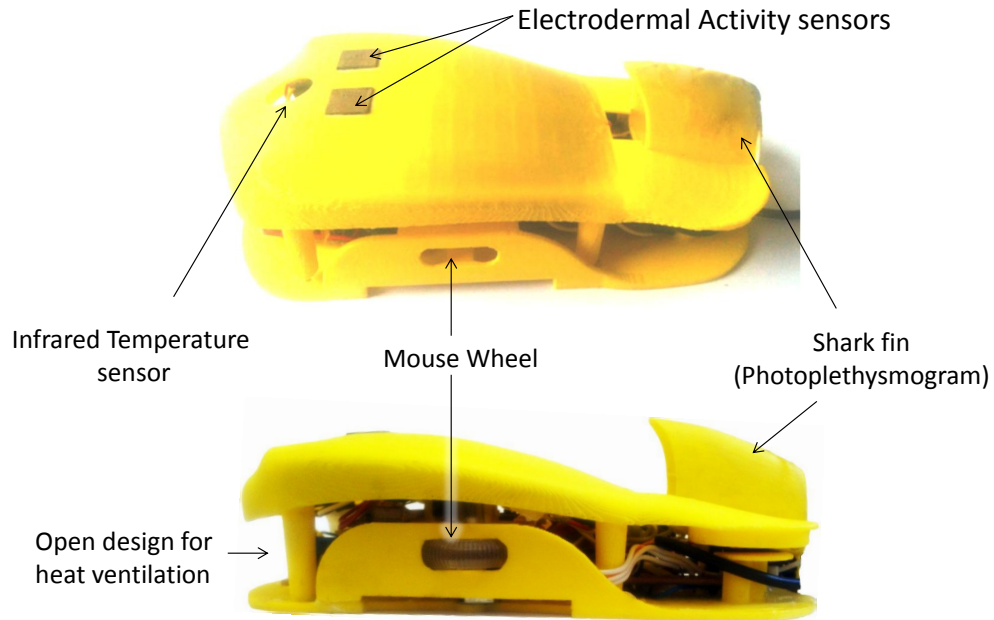

Figure 3.15: AMBER Shark-fin Mouse

4]”, where each number was represented as the following:

- 1 Blood pulse volume level.
- 2 Level of electrical conductance of the skin.
- 3 Skin temperature in Fahrenheit ( $F^{\circ}$ ).
- 4 Packet counter for payload-checksum.

These data signals are transmitted through the TX-port on the FEZ and sent through a TTL USB to serial converter. The data is sent to a PC through a standard USB-HUB.

The software code developed to operate the FEZ’s communication system and to capture the data through the serial port can be seen in Appendix A. The code for the FEZ was written in C# using Microsoft Visual Studio, while the PC data capture code

was written in Matlab. The Matlab programming language environment was used to poll (query) the serial port and store the data directly into an array.

## 3.4 Testing and Verification

A line graph of typical EDA signal taken from the device can be seen in Figure 3.16: EDA. Each sensor component was individually evaluated to measure its performance against

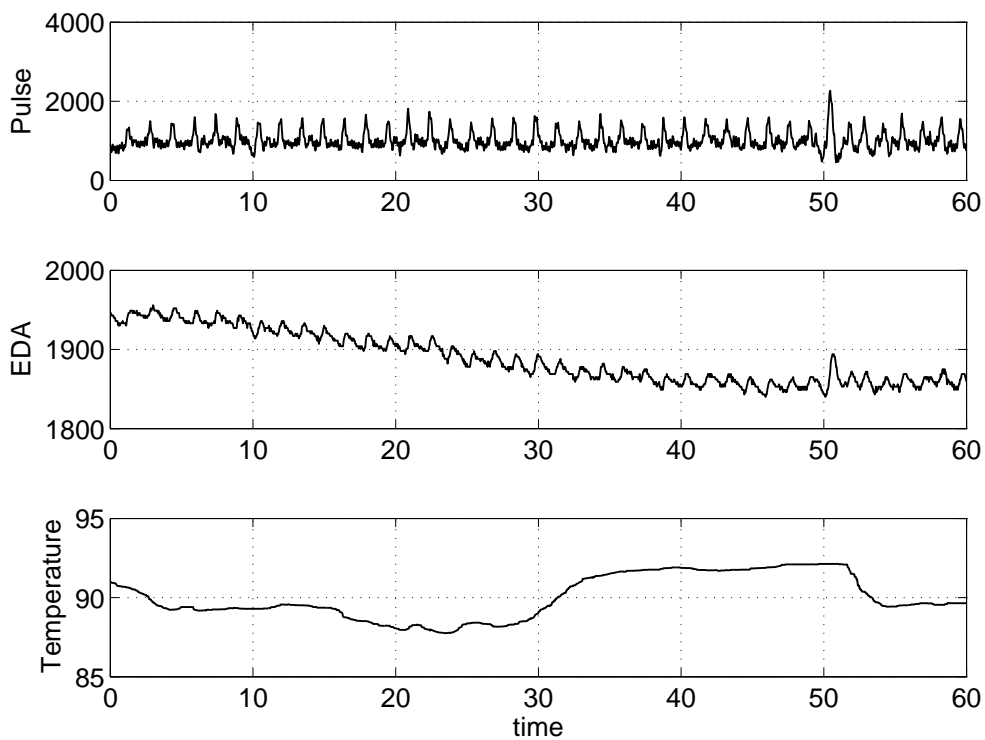

Figure 3.16: SharkFin mouse signal taken over 60 seconds during play

expected output values. Minimum and maximum range and temporal responsiveness were tested.

**Temperature:** The temperature sensor was expected to accurately respond to variances in the temperature of the skin. To test the range of the sensor, three objects with

### 3.4 Testing and Verification

extreme variations in temperature where presented to the IR thermometer's 90° field-of-view (FOV), at an approximate distance of 5.5mm. The objects introduced to the temperature sensor were ice, a hot coffee pot and a human hand. Due to the reflective properties of ice and the coffee pot, a thin layer of paper was used to defuse the reflection. This had the expected effect of marginally raising and lowering the surface temperature respectively. However, these alterations did not detract from the aim of the test, which was to measure the response of the thermometer to temperature changes.

Each object was presented one after another. The temperature data was recorded for approximately 10 seconds, which then paused for a key press while the next object was selected. The next object was then presented and the data recording resumed with a key press. Figure 3.17 shows a line graph of the temperature range in Fahrenheit over the 30 second interval of the three presentations.

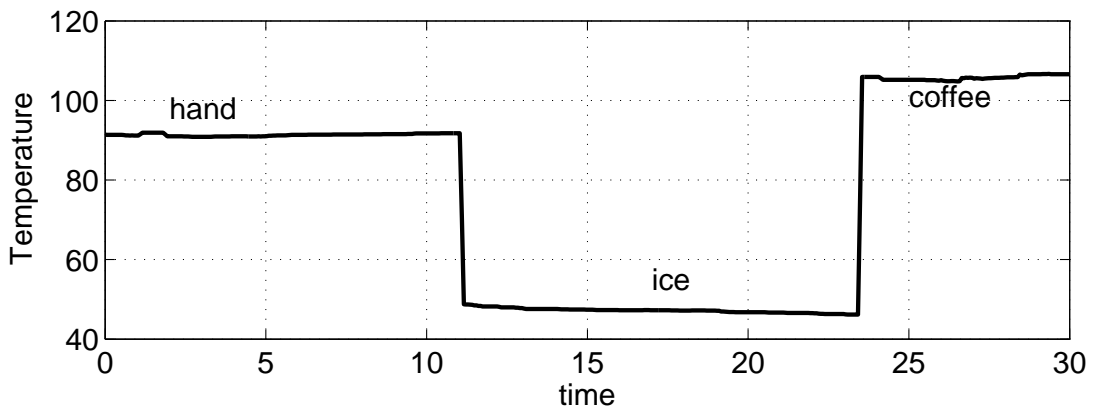

Figure 3.17: IR-Temperature 10s hand, 10s ice, 10s coffee

The expected temperature range versus the observed temperature signal can be seen in Table 3.3.

**Photoplethysmograph:** To test the functioning range of the sensor, a dense, light-absorbing card was used to completely block the light emanating from the IR-LED.

### 3.4 Testing and Verification

Table 3.3: Temperature range (°F)

Object	Minimum	Maximum	Mean observed
Hand	55	99	91.5
Ice (surface)	-30	50	48.7
Coffee	68	170	105.5

When in situ, no light was able to enter the phototransistor and therefore no current should flow through. When the card was removed, the full range of light was passed to the phototransistor and the maximum current should be produced. The minimum and maximum voltage levels are 0-volts and 3.3-volts, respectively; measured from 0 to 3300 on the FEZ. The 3.3-volt is governed by the 3.3-volt analogue input cap of the FEZ's circuitry. The card was placed in front of the sensor for approximately 5 seconds then removed for 5 seconds repeatedly, for a total duration of 30 seconds. Figure 3.18 depicts the recorded data. This test demonstrated the accurate function and sensitivity of the LED and the phototransistor.

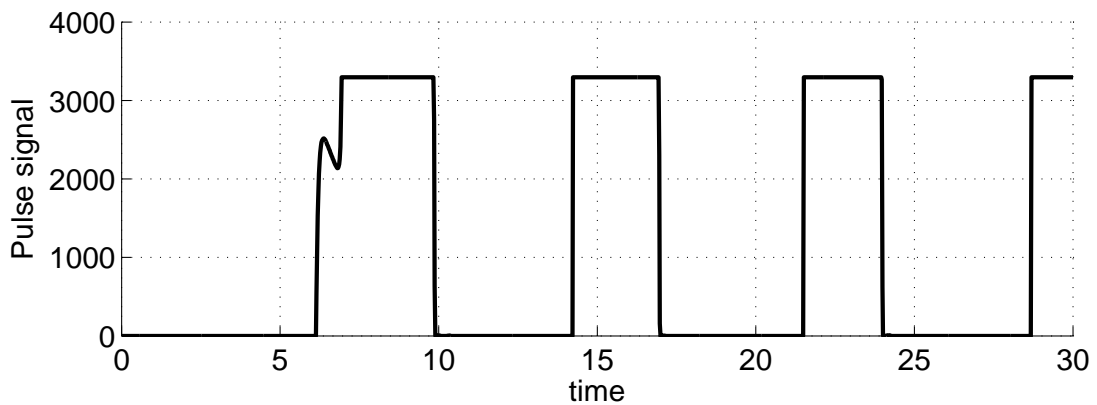

Figure 3.18: Heart Rate, 30 sec with 5sec covered 5sec uncovered repeatedly

**Electrodermal Activity:** To assess the EDA sensors, a simple hand contact test was conducted. The palm of the right hand was placed on and off the device making con-

tact with the two sensors, at intervals of approximately five seconds. The test began with the sensor untouched. This procedure was repeated for 30 seconds. Figure 3.19 demonstrates the unloaded (untouched) and loaded (touched) EDA circuit and the maximum and minimum range; 2552 and 196 respectively.

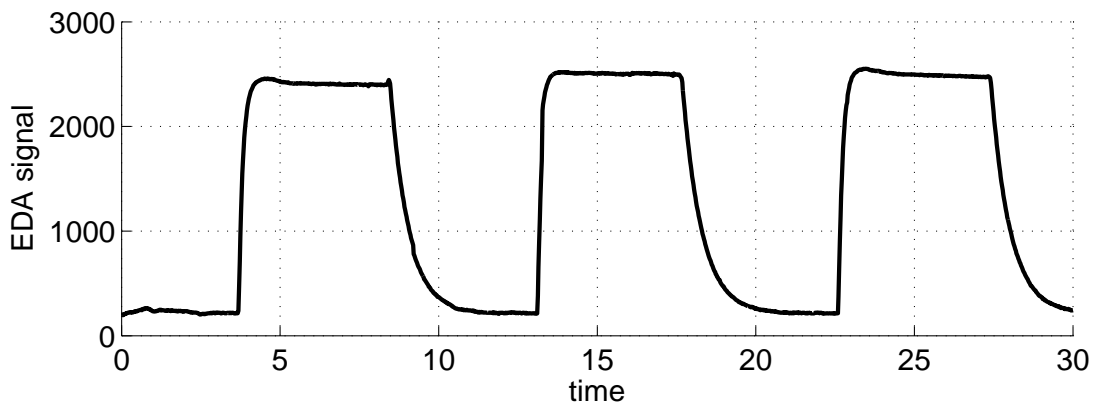

Figure 3.19: Electro-dermal activity, 30 sec with 5sec off 5sec on repeatedly

**Complete system test:** After ascertaining the sensitivity, and minimum and maximum ranges, a trial was made to determine the ability of the sensors at detecting all signals together when applying the hand onto the device. For this test, all three sensors were recorded without any contact for approximately 10 seconds. After this time, the right hand was placed on the mouse, covering both EDA and temperature sensors with the palm of the hand, and the middle finger was placed inside the photoplethysmograph cover. Figure 3.20 demonstrates the system's ability to pick up all three signals simultaneously.

As expected, the heart signal takes several seconds for the circuit to amplify the pulse. After which the pulse is cleanly detected. The EDA responded as expected with a small rise in current as soon as the sensors made contact with the skin. Similarly, the temperature sensor detected the change in temperature, from room temperature to skin

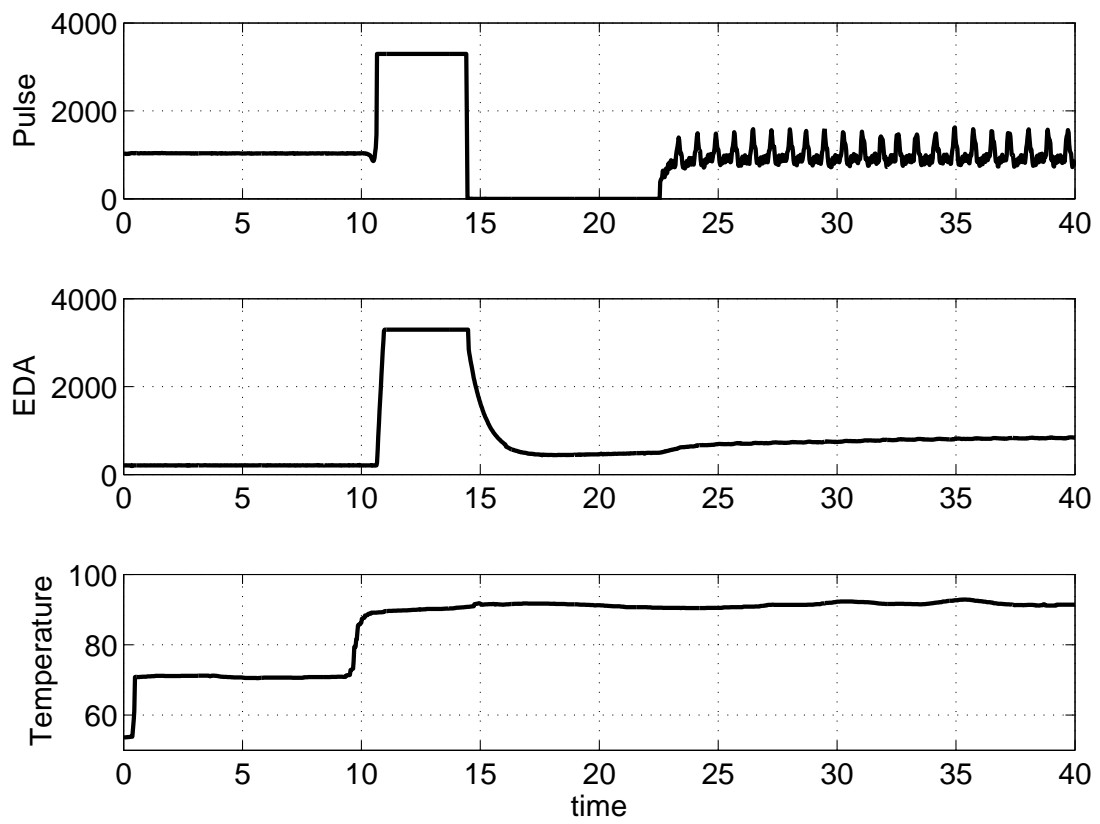

Figure 3.20: Heart rate (top), EDA (middle), Temperature (Bottom)



temperature.

### 3.5 Discussion of Results

We developed a psychophysiological sensitive input device that is capable of delivering robust signals in real time. This involved looking at every aspect of the device and sensors that makes the signal as reliable as possible. We evaluated the practicalities of using simple sensors. Moreover, we developed a system based on available hardware and carefully designed a prototype that is both comfortable and functional.

By shortening the interconnecting cable lengths, placing the digitisation and filtering hardware on-board, and altering the standard mouse shape just enough, we achieved our goal. We created an affective input device that functioned as a mouse that accurately transmitted three key psychophysiological signals, with no set-up, straps, gels or complicated start-up procedures, thus proving our hypothesis. We created the Shark-Fin affective mouse.

The next phase was to create an affectively charged gaming environment that would both stimulate the players emotion and test the functionality of the affective mouse.

# Chapter 4

## Game & User Trials

### 4.1 Serious Video Games

Serious video games are created to address issues other than purely enjoyment and entertainment [37]. They differ from classic entertainment based games in that they are designed to produce or promote important outcomes, such as education, data analysis or (in our case) affect stimulation and acquisition, among many other uses. Our game was devised to validate and test the functionality of our affective mouse.

### 4.2 Video games

Video games offer a low risk experimental environment, such that affective data can be exploited with little risk to the participant. They are pervasive throughout society and require little introduction or explanation to the participants, above the description of the game rules and concept. Games form great experimental environments, allowing every facet to be controlled and monitored.

Our experimental environment required that the user is free to utilise the shark-fin mouse as they would in a typical video game. The device needs to be familiar and comfortable. The participant should simply use the hardware as a familiar tool

and interact with the game, without the need to set up any sensors or to be connected through straps, Velcro, sticky-tape or gels.

### 4.3 Stimulating Affect Change

Before full user trials could commence, a pilot game was created to ascertain if simple emotive centred rules could act upon the players emotional state. In essence, we designed an annoying game to see if we could measure stress or frustration. The game conditions were simple:

1. Required the user to perform a seemingly simple task.
2. Add a temporal condition on the simple task.
3. Introduce hazards or to hamper the success of the simple task.

The idea was that conflicting objectives would elicit detectable psychophysiological responses, such as frustration or stress.

To determine the effectiveness of these functions, a single level concept game was written; as depicted in Figure 4.2. It was coded in the Java programming language, ensuring cross-platform support. The game concept and visuals were kept simple, such that basic shapes and colours were used to represent game assets. Assets are defined as any reusable graphics or objects of interest that can be manipulated and reused during the course of the game.

### 4.4 Game Concept

The participants were asked to use the shark-fin mouse to collect a target (white square), see Figure 4.1: (a), as fast as they could to gain the highest possible score; the Simple

Task. This had to be performed while avoiding an obstacle/hazard (black square), see Figure 4.1: (b). The obstacle would appear directly between the randomly placed target and the current mouse position, after each successful collection. Each game run was timed, with a 60 second countdown displayed on the screen; the temporal condition. If the obstacle was inadvertently selected, the player lost one of their three lives. The number of lives were graphically represented as hearts, as seen in Figure 4.1: (c). The collision of the target or obstacle were triggered by simply placing the mouse-pointer into the area-space of either object. To add an additional annoying factor, a speedometer was attributed to the mouse movement speed. Therefore, the speed of the mouse movement had to be regulated by the participant. If they moved the mouse too quickly then a speed bar (speedometer) would increase. The Speed bar determined the amount of score they would receive when collecting the target object. If the maximum speed was exceeded the energy bar would decrease and a buzzing sound was produced to acknowledge this. If the energy bar reached zero then a life was lost. The game ended when the timer reached zero or when all three lives were lost.

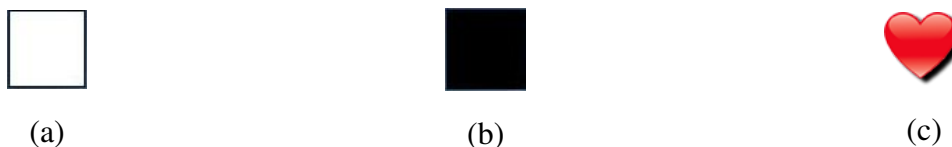

Figure 4.1: Simple graphical sprites (assets) representing Target (a), Obstacle (b) and number of lives (c).

Figure 4.2 shows a screen capture of the game during play.

**Game-state Data** In addition to presenting an interactive video-game environment, the video game parameters relating to player progress were recorded. The parameters were timestamped to correspond with the mouse's physiological data.

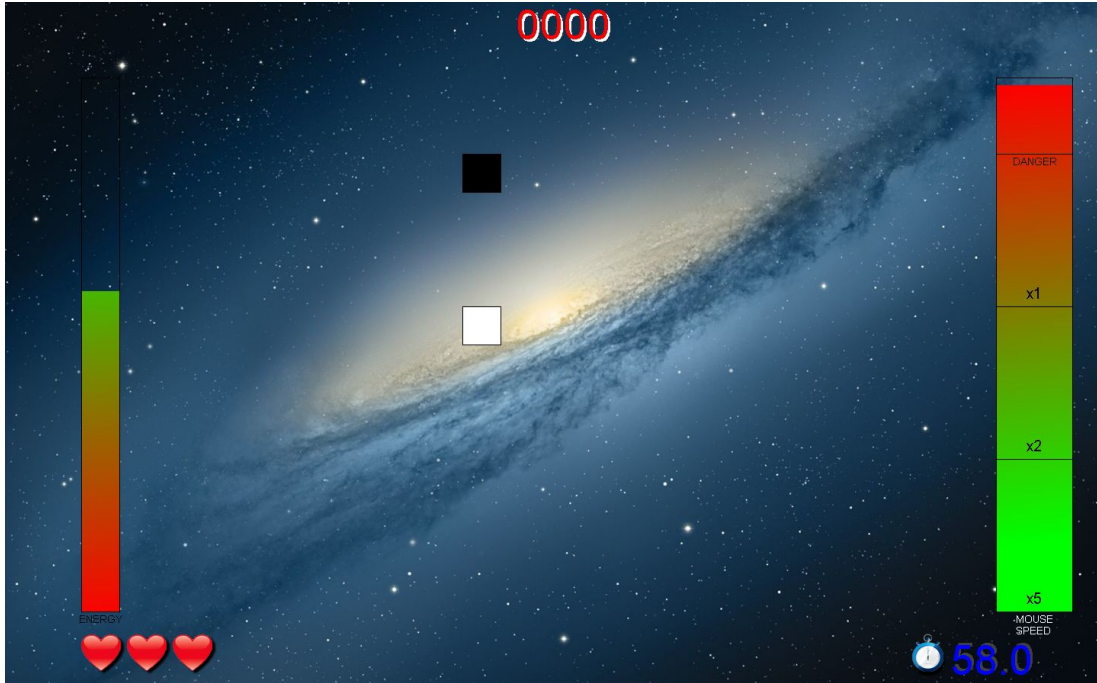

Figure 4.2: First draft proof of concept Affective Game environment.

Table 4.1: Example of game state data structure saved, during game play

Time	Lives	Energy	Speed	Countdown	Score	Event
1395066176000	3	600	40	59	5	“null”
...	...	...	...	...	...	...
1395066242000	2	342	700	35	32	“BUZZ, CLICK”

On every graphical frame, a string array of parameter-data was appended to a text file, stored in a user defined disk location. Time, lives, energy, speed, countdown, score and event data were saved. An example of the saved data structure can be seen in Table 4.1.

The *time* variable was represented by the epoch integer of the machine-clock being used. The *event* data field was a string (word) that was appended onto the end of the line of data, every time an event occurred. The word “null” was listed when no event was triggered.

The event string consisted of any or none of the following words:

- BUZZ - Mouse movement exceeds speed limit
- CLICK - Target acquired
- BOMB - Obstacle struck
- LIFE - Life lost
- ENERGY - Energy depleting
- GAMEOVER - The game has ended

**Event logging** Coupled with the other game state data, these variables allowed key-events to be logged in relation to the mouse's physiological data. The two separate data sets were correlated using the epoch, and later analysed.

Analysis was conducted on a small data sample of four participants, each playing five repetitions of the game for a 60 second duration. The mouse, game, data analysis and results were presented at the Sixth International Conference on Advances in Computer-Human Interactions ACHI 2013 [21].

In brief, the proof of concept affective hardware and game indicated that there was a small positive correlation between the psychophysiological and game-state data.

### 4.4.1 Interim Experiment Results

The results of the trial highlight the effectiveness of the device at measuring clean physiological signals from a fully functional mouse, while playing a video-game. Figure 3.16 demonstrates the quality of the signals achieved during a live game trial. To test the potential of the proposed device at emotion recognition, we carried out off-line

analyses of the data. The data consisted of the three variables (HR, EDA and skin temperature) measured along the whole approximately 90-second long game run. Each value in the sequence was the average of the previous 3 seconds of the signal. The pulse signal was transformed into pulse rate by the following steps:

1. The raw curve was smoothed with a window of  $\frac{1}{2}$  a second and then with a window of 1 second.
2. The locations of the peaks in the signal were identified.
3. The intervals between the subsequent peak locations was used to approximate the heart rate.
4. A linear interpolation was used to set the heart rate values between the peaks.

Two categories were formed. Assuming that the player is in state ‘Calm’ during most of the game run, we hypothesised that certain situations would provoke a negative state which we labelled ‘Agitated’. In this experiment, a state was labelled as ‘Agitated’ if all of the following held:

- The speed of the mouse exceeds a threshold of 200.
- The countdown clock indicates less than 25 seconds left.
- The player has lost at least one life thus far.

For example, game #3 produced 4,129 data points, 56 of which were labelled ‘Agitated’ (3.78%), while the remaining points were labelled ‘Calm’. After removing the outliers (EDA signal less than 500 and temperature signal less than 50), and concatenating all 20 games, we obtained a labelled data set with 60,684 data points with 5,332

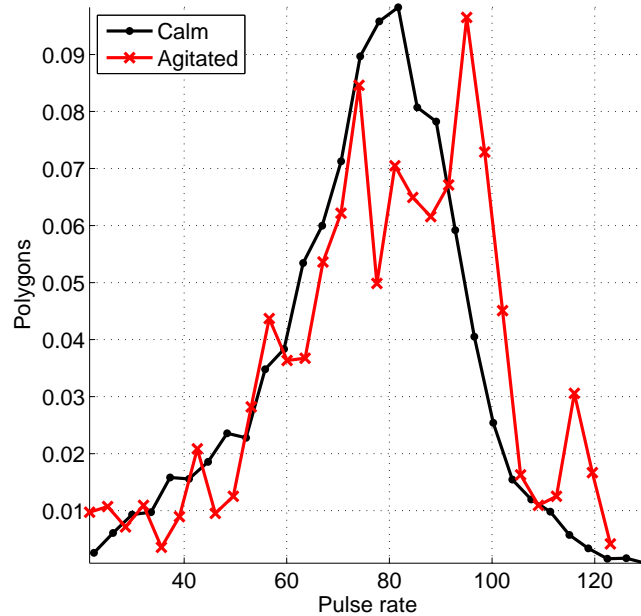

Figure 4.3: Polygons for classes ‘Calm’ and ‘Agitated’ for the Pulse Rate

data points (8.79%) in class ‘Agitated’. The task of developing a proper real-time classifier for such an imbalanced data set is one of our future lines of research. Here we are interested to find whether there are differences between the distributions of the two classes. A histogram was calculated for each of the three features and each class. The polygons of these histograms are shown in Figures 10, 11, and 12.

The polygon for class ‘Agitated’ has a more jagged appearance than the one for class ‘Calm’ because it was calculated from much fewer data points. More importantly, however, all distributions for class ‘Agitated’ are slightly shifted to the right, indicating increased Pulse Rate, [EDA](#) and Skin Temperature.

These findings are consistent with increased level of anxiety [71], which demonstrates the ability of the proposed device to output genuine and useful signals.

This warranted the design of a more user-involved video game trial, having varying levels of difficulty and more participants.



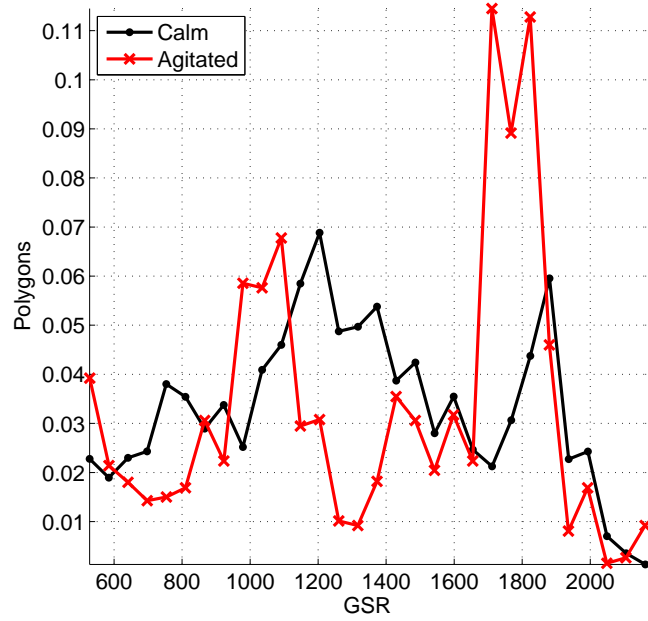

Figure 4.4: Polygons for classes 'Calm' and 'Agitated' for the [EDA](#)

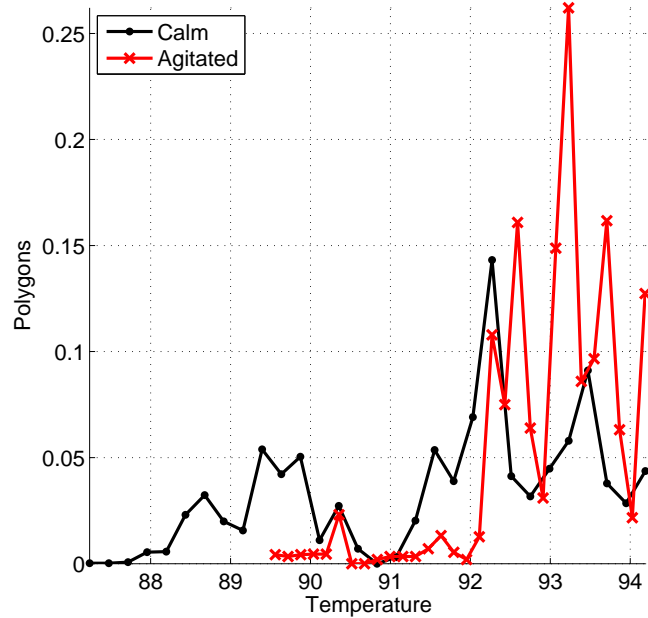

Figure 4.5: Polygons for classes 'Calm' and 'Agitated' for the Skin Temperature

### 4.5 Enhanced Full Game

Following the success of the previous game pilot study, a larger video game trial was needed, to ascertain the reliability of the mouse PPG signals. The next version had to represent a typical game, having varying levels of difficulty, to invoke more diverse participant (gamer) emotive responses. Among the changes, were improved graphics, diverse scoring and ten levels of varying difficulty.

#### 4.5.1 The video game

The new game followed the theme of the previous version. It involved moving the mouse over a randomly appearing white rotating target, while moving avoiding meteors and asteroids. Points were scored when the mouse touched the target. The number of points scored were determined by the speedometer, linked to the mouse. There were ten levels, each played for sixty seconds and each with differing degrees of difficulty. Between each level there was a thirty second relaxation period. This was introduced to allow any psychophysiological signals to relax, before the next active level. Each level presented to the participant a varying number of meteors and asteroids, with more appearing in harder levels.

One asteroid would always appear in-between the mouse cursor and white target. Other asteroids would rotate around the target, in a gravitational field. One meteor would always chase the participant's cursor while the others would move across the screen at varying speeds and oscillating wave-formations. Each level also altered the scoring rate and the sensitivity of the speedometer, making it difficult to determine a fixed *safe* mouse movement speed.

The game screen-shot is shown in Figure 4.6, highlighting the games assets.

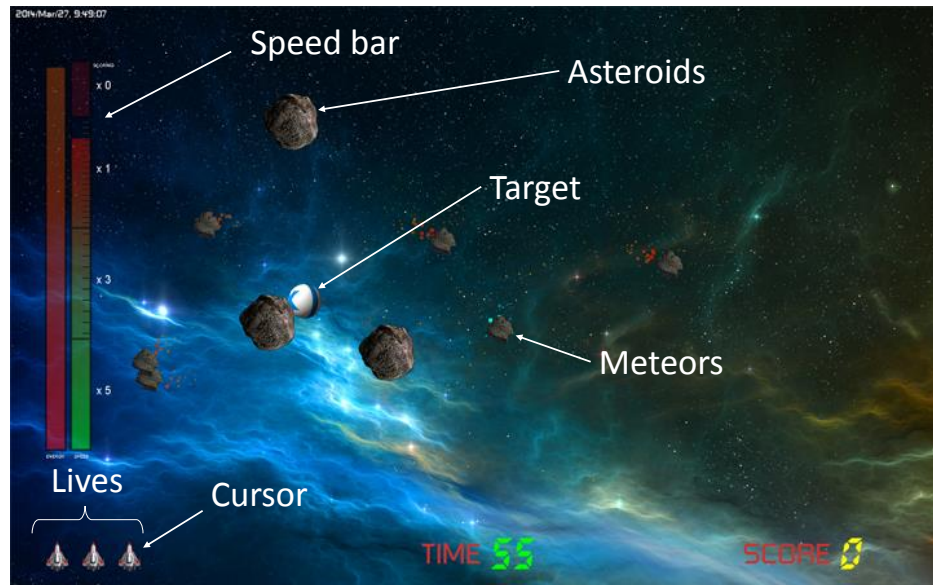

Figure 4.6: A screenshot from the video game.

The game was specifically developed to attempt to invoke mild levels of stress. This was done by penalising fast movement of the mouse, while at the same time requiring a high movement speed in order to collect the target in a short time, while avoiding fast moving obstacles. A mouse speedometer was displayed as a vertical bar on the left of the screen. The player would have to monitor their speed, score, timing, and avoid obstacles. The points scored for collecting the target was variable, according to the speed of the mouse. The slower the mouse movement, the higher the score when the target was collected. If the player moved the mouse too fast, the speedometer entered a danger zone. Entering the danger zone decreased the energy-bar. During this time, no points are scored. If the energy bar reached zero, a life was lost. Each game level ends after the counter reached zero or all three lives were lost. The game played for a total of ten levels, per participant.

Figure 4.7, 4.8 and 4.9 depict the game scene, the game augmented with the motion

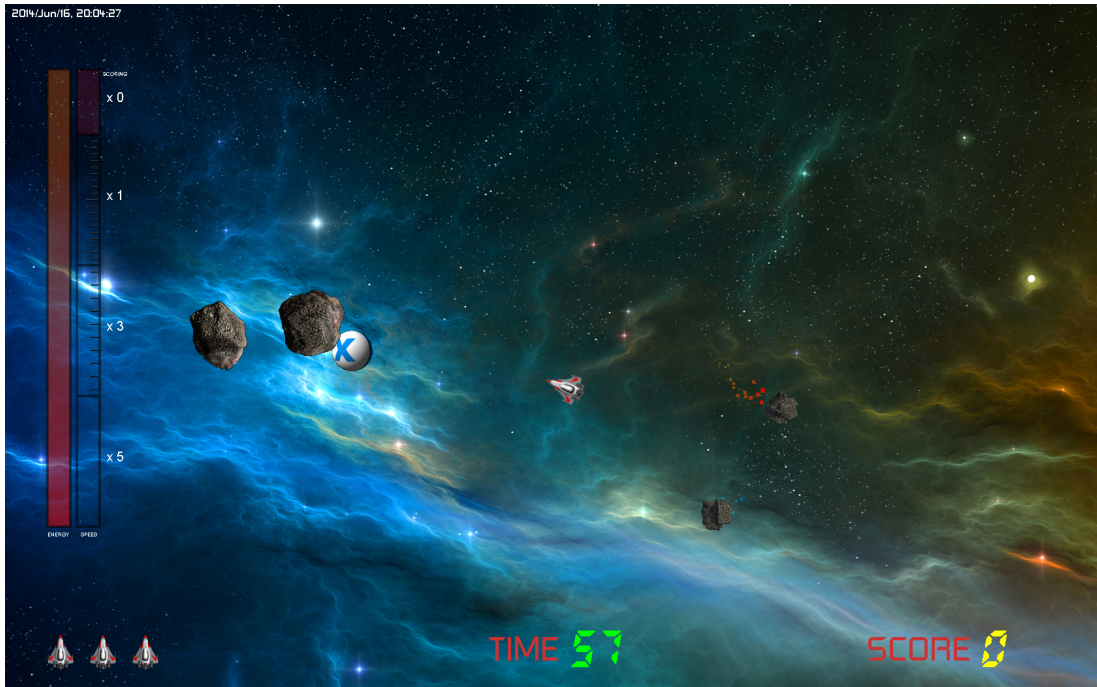

Figure 4.7: Video game in action, depicting a screenshot of the standard video game.

trajectory lines and the game in debug mode, respectively.

Audio signals were included to add to the potential irritation, at various stages of the game. A buzzing sound was produced when the speed increased beyond a maximum threshold limit on the speed bar (the danger zone). A crashing sound was played upon a collision with an asteroid. A rasping sound was played when colliding with a meteor. When a life was lost, the player had to listen to another sound signifying defeat. Losing a life also forced the player to wait without being able to move the cursor for 5 seconds. If an attempt to move the mouse was made during this time, a warbling alarm-sound was played.

### 4.5.2 Experimental set up

The video game was used within the following experimental scenario:

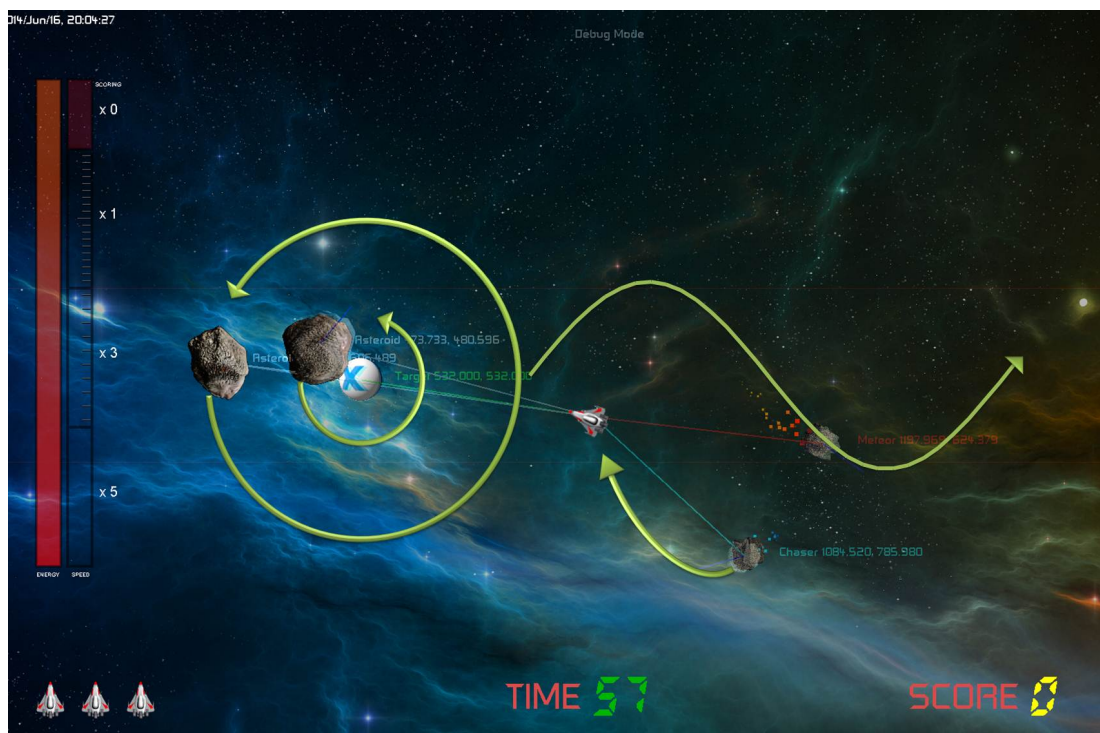

Figure 4.8: Video-game screen-shot showing meteor and asteroid trajectory lines, including faded collision distances.

## 4.5 Enhanced Full Game

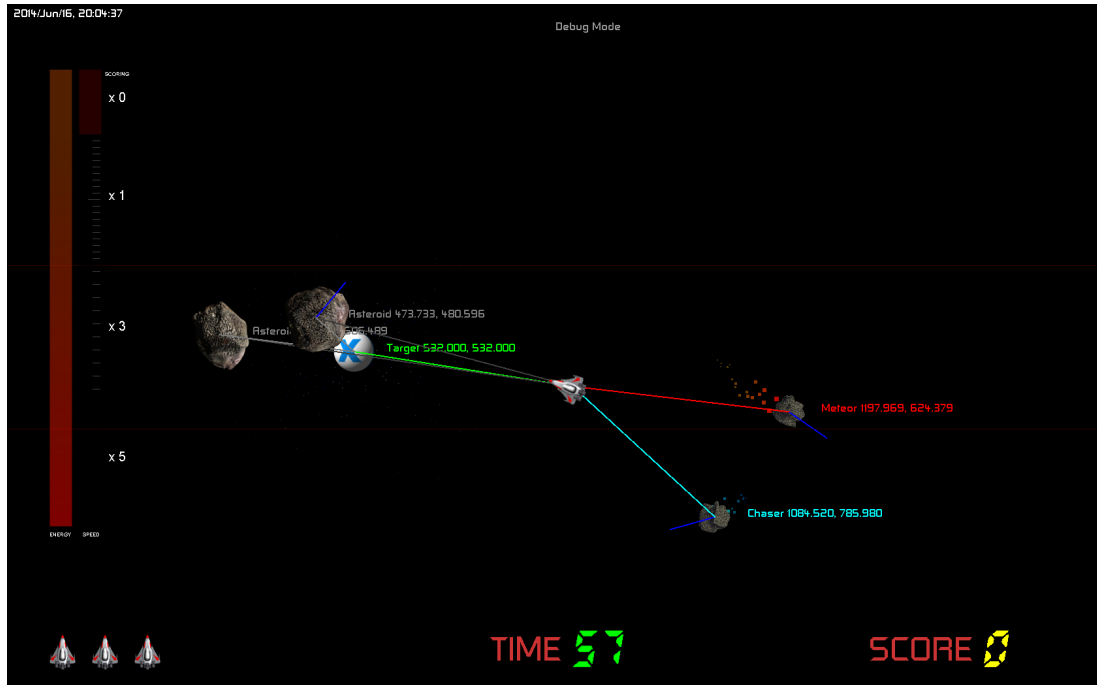

Figure 4.9: Debug mode, which shows collision interaction game parameters, and removes moving space background.

1. A verbal consent was obtained from the participant to have their data and facial expressions recorded and used for further analyses.
2. The participant was shown the instructions to the game (Figure 4.10) and was given a short opportunity to ask questions and test their understanding of the game rules.
3. The experimenter ensured that the data streaming was working properly before allowing the game to commence. Then the player was left to play the game uninterrupted.
4. Each experimental session comprised of ten game levels.
5. The timer for each level was set to sixty seconds. The level finished if either the

timer reaches zero or the player lost all their lives.

- Each level began with three lives. Lives were lost when the energy bar reached zero. The energy bar was depleted when either the space ship cursor collided with an asteroid or meteor, or the mouse speed exceeded a specific threshold.
- There was a sixty second fixation period before the new level started. The participant was asked to relax and wait for the next level.

The experimental period lasted approximately 20 minutes.

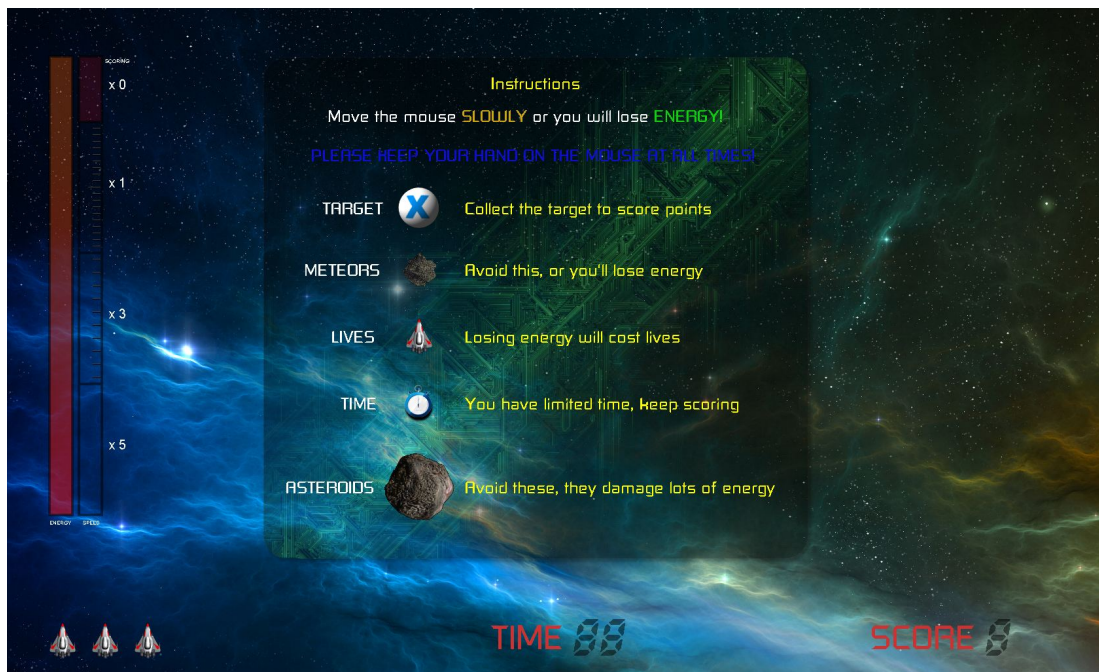

Figure 4.10: Instructions shown to the player before the game commenced.

### 4.5.3 The experimental environment

In addition to changing the game, we constructed a quiet zone environment; a booth where the game could be played without disruption. Having the player fixate on

## 4.5 Enhanced Full Game

nothing but the video-game ensured the cleanest possible signals. A sound and light-blocking booth was constructed where the participant's monitor, the Shark-fun mouse and a camera (to record facial expression) were placed. The environment for the experiment is illustrated in Figure 4.11.

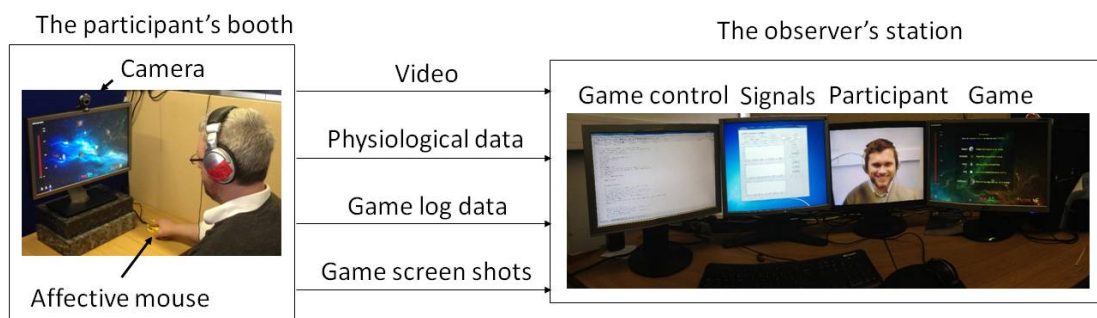

Figure 4.11: The experimental environment

The booth was built from blackout sound boards, which was designed to remove excessive light and external visual and audible distractions. The participant was asked to wear Circumaural (full sized) headphones, to hear the game sounds and block out other potential audible distractions. The participants view, during an active video game session, can be seen in Figure 4.12.

The experiment was run on two separate computers. One computer ran the game, collected the game-state data and recorded the video game being played in full screen. The other computer collect the physiological data and the participant's facial expressions. The computation required to run a video game, store the game-state data to disk, capture full screen video, record the participant's facial expressions and finally record the mouse data, would have pushed many a system too far. Video game and face camera video capture were recorded using *Debut Video Capture Software*. Game state data logs were integrated into the video game, using Java. The psychophysiological data





Figure 4.12: Videogame experiment booth, highlighting the participant uninterrupted view.

was recorded using Matlab.

We used two identical 64 bit, Windows 7 based PCs, both running on Intel® Core™ i5-2400 CPUs at 3.10Ghz, with 8GB of RAM, and an nVidia GeForce GTX 550Ti GPU. The video game machine was set-up with twin monitors, cloning the video game display. One screen was for the participant and the other for the monitoring researcher, see Figure 4.11. The mouse data cable was split from the USB-HUB, with the mouse movement data going directly to the game computer and the physiological data stream going to the physiological capture computer (PCC). The PCC connected to three monitors. One monitor was used to control the game and data collection. The second monitor showed the three physiological signals streamed from the mouse, see Figure 4.13. The third monitor, displayed a live stream of the participants facial expressions, which was also recorded. The observation station had a fourth monitor, showing the cloned view from the game machine, see Figure 4.11.

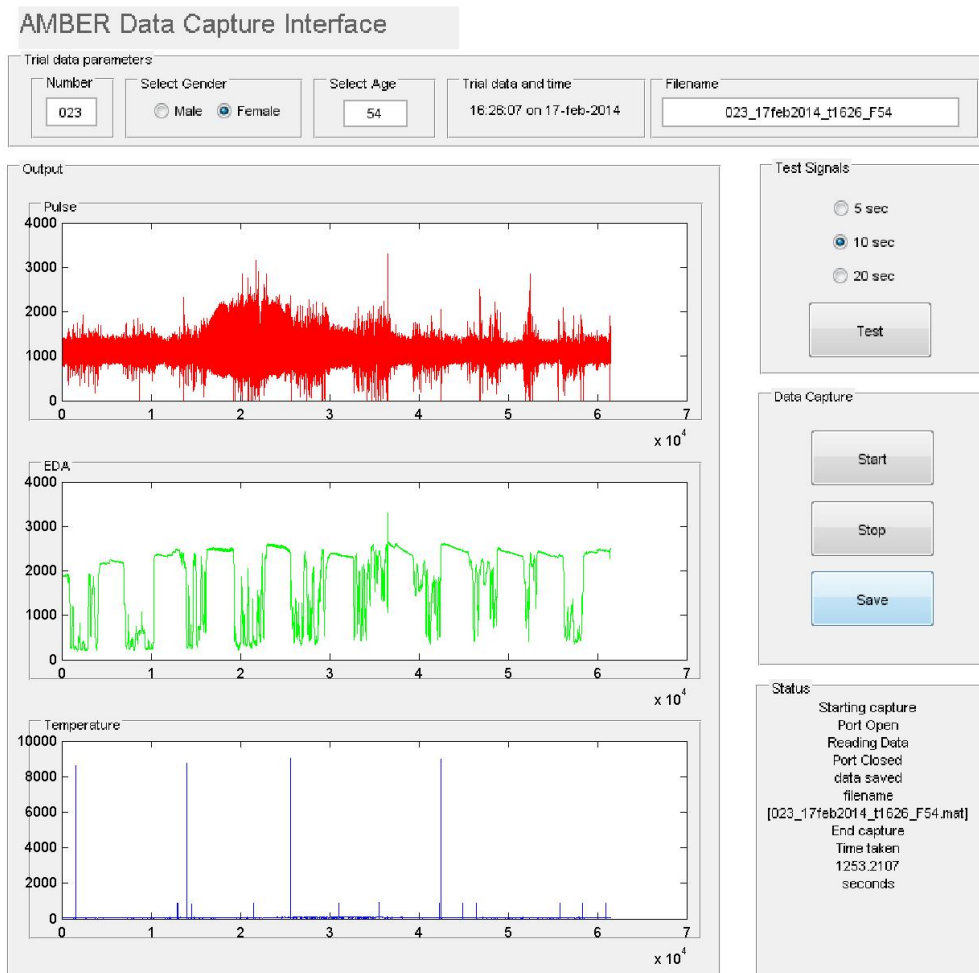

Figure 4.13: The data capture graphical user interface. Showing the data from the entire duration of the game. Depicting Pulse (top, red), EDA (middle, green) and temperature (bottom, blue).

Table 4.2: Game state EVENT data.

Hour	Minute	Second	Millisecond	Level	Lives	Energy	Speed	Immunity Timer	Countdown	Score	# of Asteroids	# of Meteors	Event
12	29	53	645	4	3	645	24	0	57	159	2	2	-
12	29	53	696	4	3	621	95	0	56	164	2	2	96
...	...	...	...	...	...	...	...	...	...	...	...	...	...
12	29	29	236	4	2	800	0	3	29	178	2	2	131072

#### 4.5.4 Data logging

Like the proof of concept, the data streams were recorded in two files. The first stored the computer game event data. The second recorded the biometric sensor data. For each file a time-stamp was stored along with each iterative data point to enable temporal comparisons of the game-play and biometric data. We ensured that the computer clocks were synchronised using *time.windows.com*. Then both computers individually stored their current time with every frame of data saved. The game data was logged as seen in Table 4.2.

Event data was stored as an integer, which was only generated when an event occurred in any given animation frame. If more than one event took place in a frame, the event integer values were summated. Each event tag increments by  $2^n$ , where  $n$  represents the index value of the event, as seen in table 4.3. If a SCORED event took place then the stored integer value for that frame would be 32. However, if the SCORED and START\_TICKING event took place in the same frame, then the value would be 34, e.g.  $32 + 2$  and so on. This enabled any number of event values to be stored in a single integer byte variable. It also simplified storing and importing the data into Matlab for

analysis.. The EVENT variable is detailed in Table 4.3.

Table 4.3: Game state EVENT decimal binary key.

Event	Integer Key	Explanation
STARTING	1	Triggered when each level begins
START_TICKING	2	Clock ticking sounds when $\leq 15$ seconds remaining
TEN_SECOND_TIMER_BEEP	4	Audible final 10 seconds remaining countdown beeps
TIMES_UP_TIMER_BEEP	8	Audible long beep when level ends
RESTARTING_GAME	16	The point when the next level begins
SCORED	32	Each time a player scores
TOUCHED_METEOR	64	Each time the cursor collided with a meteor
TOUCHED_ASTEROID	128	Each time the cursor collided with an asteroid
TOUCHED_BALL	256	Each time the cursor collided with the target
SCREEN_FLASH	512	Screen flashes white to synchronise face recording
GAMEOVER	1024	The game has finished
BUZZ	2048	Audible sound when mouse moved too quickly
LOSE_ENERGY	4096	Loss of energy
LOSE_LIFE	8192	Life lost sound
SAVING_STOPPED	16384	Data-Save-Start time stamp for analyses
SAVING_STARTED	32768	Data-Save-Stop time stamp for analyses
GAME_PAUSED	65536	Triggered any time the game instructions were displayed
ZAP	131072	Audible sound if mouse moved before 5 second starting pause

The *physiological* data file contained the time-stamp (hour, minute, seconds), a chronological checksum counter (one count per data point), followed by the three physiological signals (pulse, EDA and temperature).



Figure 4.14: Video game assets, which are animated during game play; target (a), meteor (b), asteroid (c), player sprite/life (d) and moving nebula background (d).

Details of interesting game mechanics are given in Appendix D.

### 4.6 Summary

The hypothesis that ‘A simple video game, designed to stimulate small changes in emotion corresponding to game ‘events’, could stimulate detectable and useful psychophysiological data’, is explored.

We developed a simple video game that was able to stimulate mild levels of emotional change, which is surmised as stress. Furthermore, we demonstrated that through the physiological data from the mouse alone, changes corresponding to game state data were detectable. We describe the planning and development process of producing an affective video game and an accompanying experimental environment. The chapter presents a more challenging game, based on the first, designed to challenge the player; stimulating greater detectable change in the players emotion. We considered what parameters would be important to take forwards for analysis. The experiment environment and setup and the operative procedures are explained, including the systems used. It is considered that the hypothesis was proven. Given the interim proof of concept game, we consider that the hypothesis was proven true.

Following the completion of the experiment for data collection, the next stage was to empirically analyse the newer data in more detail.

# Chapter 5

## Psychophysiological Data Analysis

The data from 15 participants (13 male and 2 female) were recorded during game play, as explained in Section 4.5.2. The average age of the participants was 35.13, minimum 21 and maximum 54.

The facial expression data, and the game video frame sequences were recorded. This data was collected as a backup measure, to ensure that if more evidence of 'emotive' data was required that it was available. Our results did not necessitate the need for this backup measure. Therefore the facial expression data was not used in these analyses.

### 5.1 Feature extraction

Based on previous experiments with affective physiological data, eight features were taken forward

The classification features were extracted using a Matlab toolbox called Affective-Toolbox [73]. The AffectiveToolbox extracts 'features' from the raw physiological data, utilising the following functions: ExtractEEG, ExtractEMG, ExtractEOG, ExtractGSR, ExtractHR, ExtractRESP, ExtractTEM. The features used for our

analysis are shown in Table 5.1.

Table 5.1: Features extracted from the physiological data streamed by the affective mouse.

Modality	Feature
<b>EDA</b>	Average Average derivative Average negative derivative Proportion negative derivative
<b>PPG</b>	Average heart rate Average peak amplitude
Temperature	Average Average derivative

Using Matlab, each player’s collected file, game and mouse (physiological signals) data were parsed to extract the appropriate variables. From the saved file we took the filename, experiment number, day, month, year, time, gender and age.

From the game data, we extracted the time, level, lives, energy, speed, invulnerability timer, countdown timer, score, the number of asteroids, the number of meteors and the event game-state values. And from the mouse (physiological) data, we took the **PPG** (blood volume), **EDA**, temperature, checksum counter and current time values.

The data streams, from both the mouse and the game-state, were aligned temporally. The physiological signals were filtered, to remove spikes in the data. This was to overcome a known error in the temperature data, where the decimal point would sometimes be lost during transmission. This was occasionally seen in the data as a huge spike in value. Where the previous value might read 96.53 °F, with the next value being 9654, then its proceeding value being 96.55.

Since each of these features requires a window, we experimented with three window sizes: 3s, 10s and 12s. We note that extracting more intricate features from the physiological data may not be very useful. It is likely that all three signals may be

affected by movement or changing of the position of the player's hand on the mouse.

Consequently, the signals from the physiological sensors may also contain information which can be attributed to behavioural input modalities. As we will not aspire to recognise a specific emotion, but rather a change in the emotive state of the player, the interpretation of the raw signals, even of the extracted features, is not important. It is more interesting to find a relationship between changes in the signals and game events, which could be related to excitement or annoyance. Recognising such states from the player's physiology will form the basis of affective feedback that can be integrated within the game scenario.

## 5.2 Visual Overview

Visual analysis of the data was conducted to assess any patterns of data that *stood out*. We created a visual representation of all the data collected in a single image, see Figure 5.2. The image representation was generated for each participant.

For each *game event* a symbol (key) was appointed, then augmented with the game-state data streams onto the plot. The plot consisted of the psychophysiological sensor data and the entire game state data, such as energy levels, lives, score, etc., see Figure 5.1

This approach revealed some interesting results. The *first* was that some physiological responses to game-related events reveal a build-up or pre-emptive period. For example, suppose that the cursor collides with an asteroid, and a life is lost. The physiological reaction of the player is likely to have started a few seconds earlier than the logged event, when the participant observed the imminent collision. To account for this, we carried out experiments where we allowed for pre-labelling of events by



○	STARTING_EVENT
x	START_TICKING_EVENT
+	TEN_SECOND_TIMER_BEEP_EVENT
□	TIMES_UP_TIMER_BEEP_EVENT
◇	RESTARTING_GAME_EVENT
△	SCORED_EVENT
V	TOUCHED_METEOR_EVENT
☆	TOUCHED_ASTEROID_EVENT
*	TOUCHED_BALL_EVENT
□	SCREEN_FLASH_EVENT
◇	GAMEOVER_EVENT
□	BUZZ_EVENT
*	LOSE_ENERGY_EVENT
+	LOSE_LIFE_EVENT
☆	SAVING_STOPPED_EVENT
V	SAVING_STARTED_EVENT
x	GAME_PAUSED_EVENT
○	ZAP_EVENT

Figure 5.1: Augmented data plot key

several seconds. The correlation of signals-to-events taking effect before the actual recorded event was surprising. Physiological signals have a short delay in taking effect [128]. This pre-response could signify that the physiological changes were changing to visual stimuli and cues before the event was triggered, such as pre-empting the trajectory of an asteroid signalling an unavoidable collision. Arguably, such a response could also be the effect of motion artefacts, in an attempt to evade the pending collision. Such a finding would continue to render the data useful in a video game environment [130, 140]. The *second* interesting finding was that the heart rate waveform signal amplitude strongly responded to game-play.

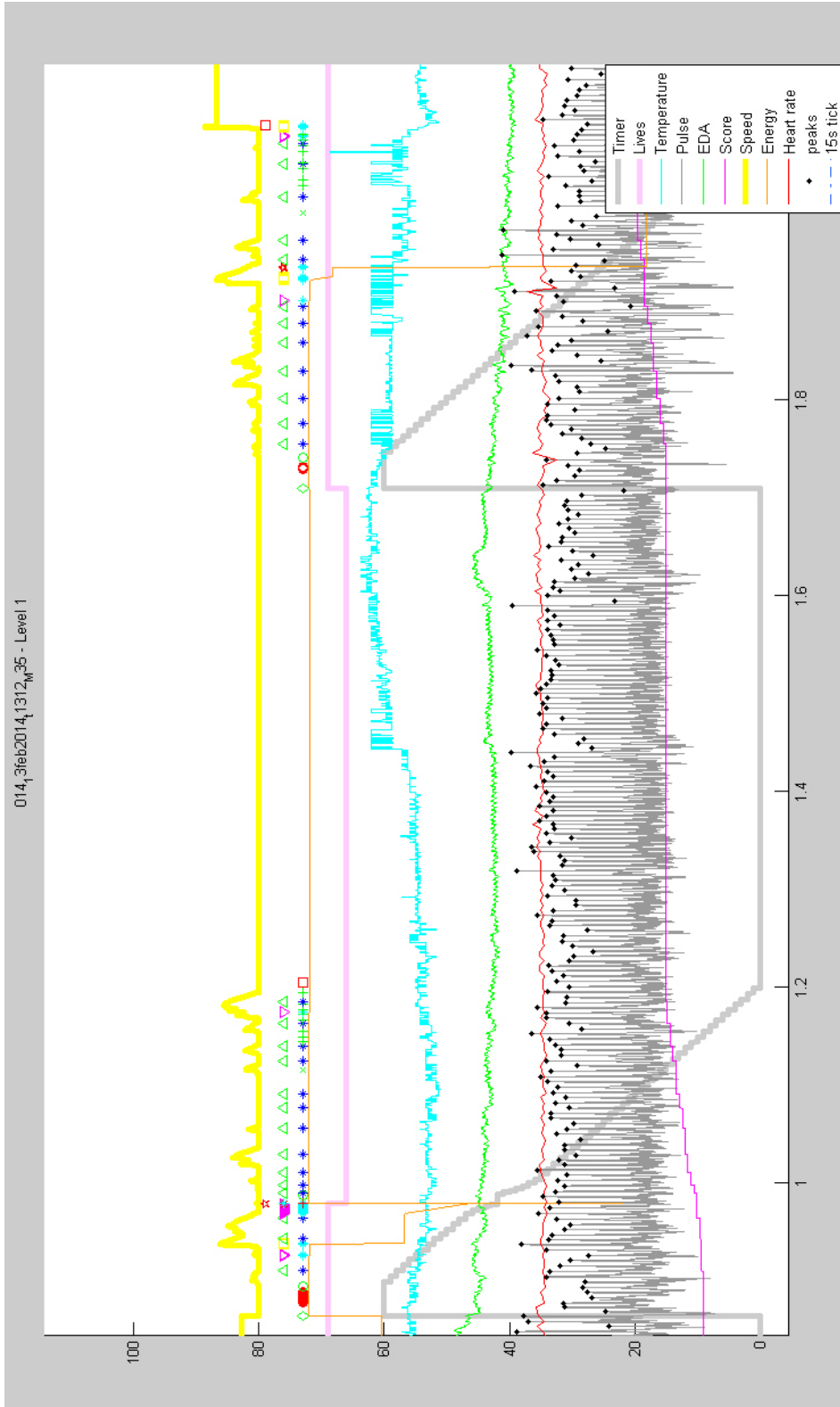

Figure 5.2: Augmented data plot time-line: showing a plot of all streams data combined; three physiological signals, game state variable values (such as score, lives, energy, etc.) and triggered 'events', see Key in Figure 5.1. Such that, all the data was overlaid together on the same time-line. Heart rate peaks displayed with black dots.

From the photoplethysmograph, two parameters are extracted for our experiment, heart rate interval and the signal waveform amplitude. The pulse rate, demonstrated by the variation of distances between peaks in the HR signal waveform, showed little temporal variability throughout our trials. One reason might be that our game did not evoke a particularly strong emotional response, as perhaps experienced in games like *Resident Evil* [18] or the *Left for Dead* [139] series.

However, the signal waveform amplitude showed a clear responses to the video game stimuli. Figure. 5.3 shows a twelve second window of two signals; PPG and EDA. The window highlights the point (vertical line) at which a participant leaves the fixation period and begins level 9; which was a particularly difficult level.

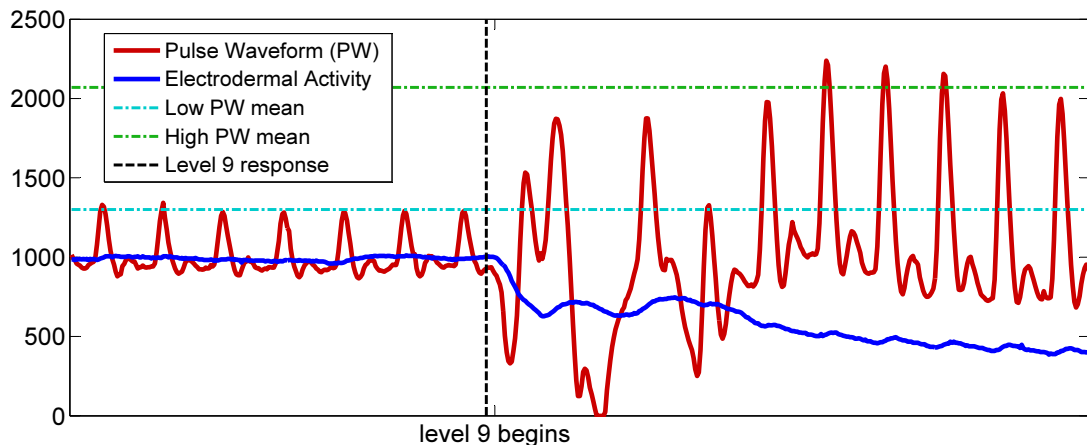

Figure 5.3: The point of change in Blood Volume Amplitude level variance, between fixation period (cyan) and level 9 game-play (green), including the correlation with EDA variance (blue), demonstrating a clear physiological response.

This change demonstrates that the participant quickly became physiologically aroused by the change in stimuli. It is worth noting that the previous level (level 8) was extremely easy, having only a slow chasing meteor for the participant to contend with. Level 9, however, was nothing of the sort, having a fast chasing meteor, four randomly

spiralling meteors and four highly damaging orbital asteroids. It is reasonable to surmise that the participant may have felt startled or surprised by the sudden change in difficulty. This is indicated by the contaminated signal or motion artefact in the three seconds immediately following the commencement of the level.

Figure. 5.3 also shows the correlation of the EDA to the PPG signal responses. The EDA signal altered with equal levels of intensity. However, EDA is extremely sensitive to movement artefacts. The sudden change in EDA values when the game levels begin have been a common theme, throughout most of the participants. Our analysis does not investigate if these changes were predominantly derived from electrodermal responses or changes in mouse pressure. Nevertheless, along with typical measures of the dermal layers, changes in contact pressure is also an indicator of stress [130, 140]. Therefore, the EDA signals maintain utility for affect acquisition and analysis, with either finding.

We employed several classification methods to determine any empirical correlation between the video game and the physiological data.

### 5.3 Classification methods.

A set of classifiers and classifier ensembles were chosen for the experiments.

The detailed methods implemented for each classifier are beyond the scope of this thesis. However, we give a basic overview of each.

All methods are implemented within WEKA [49, 99]. The methods were as follows (given in brackets are the acronyms used in the related tables and figures):

1. *The Largest Prior (LP)*. This classifier assigns the label of the prevalent class to all objects. The class proportions are estimated from the training data.
2. *Nearest neighbour (1-nn)*. The label assigned to an object is the label of its

nearest neighbour from the training data.

3. *Decision tree (DT)*. The label of an object is assigned by making a sequence of decisions traversing a path in a tree. The tree is built using the training data.
4. *RBF neural network (RBF)*. RBF is one of the most popular models of neural networks. The implementation in WEKA trains of one hidden layer of neurons using clustering of the training data. Symmetric multivariate Gaussian (the RBFs) are built on the cluster centroids, and the weights to the output layer are fitted by a logistic regression. The default number of clusters is two.
5. *MLP neural network (MLP)*. The multi-layer perceptron (MLP) classifier is also among the most widely used neural networks. In WEKA, the default options are a single hidden layer with number of neurons equal to  $(\text{features} + \text{classes}) / 2$ . In our experiment, there are 8 extracted features and two classes, hence the number of hidden nodes is 5. WEKA offers various versions of the MLP training. The parameters of the default version are: run the training for 500 epochs with learning rate 0.3 and momentum 0.2.
6. *SVM classifier (SVM)*. (SMO in WEKA) The Support Vector Machine classifier (SVM) was originally proposed for two classes. It maps the original space into a very high dimensional space and draws a linear boundary there. WEKA provides a multi-class extension whereby every pair of classes is used to train the SVM, and the classification decision is taken by majority vote at the end. In our experiment we will be using two classes, so the multi-class extension does not apply. By default, the WEKA implementation normalises the data before training the SVM. The default kernel is the linear kernel, which means that the projection of

the linear discriminant in the high-dimensional space to the original space will also be linear. The default regularisation parameter is  $C = 1$ .

7. *AdaBoost (Ada)*. This is an ensemble method, which builds each subsequent classifier in the ensemble by re-weighting (the default option) of the objects in the training data set based upon their ‘difficulty’ thus far. The base classifier is a decision stump, which means that the class label given by a classifier in the ensemble is obtained by comparing a single feature value of the object with a threshold. Only 10 iterations are carried out, thereby building an ensemble of 10 classifiers.
8. *Bagging (Bag)*. This is also an ensemble method, where each classifier in the ensemble is trained on a bootstrap sample from the training data. Again, 10 classifiers are built, according to the default parameter. This time, however, the decision trees are of type REPTree, which ensures better accuracy of the individual ensemble members compared to AdaBoost.
9. *Rotation Forest (RoF)*. This ensemble methods usually works well for large number of features. It is based on partial rotation of the space before training an ensemble classifier. The ‘forest’ in the name, indicates that this method works best with decision tree classifiers (J48) as the ensemble members. Like the other ensemble methods, the default ensemble size is 10.
10. *Random Forest (RaF)*. This ensemble methods is similar to Bagging, apart from the base classifier. While Bagging does not specify a base classifier, this ensemble method uses the so called Random Tree. The default ensemble size is 10.

All methods were examined using a 10-fold cross-validation protocol.

### **10-fold Cross Validation**

- Break data into 10 sets of size  $n/10$ .
- Train on 9 datasets and test on 1.
- Repeat 10 times, rotating test set.
- Take a mean accuracy.

**Variance-corrected t-test.** For a pairwise comparison of classification accuracies of the chosen methods across the 15 participants, we used the statistical test offered by WEKA. The equivalence of the means is calculated by paired two-tailed t-test with a correction of the variance proposed by Nadeau and Bengio [92].

**Wilcoxon signed-rank test with Bonferroni correction.** To compare the classification methods with one another using the 15 participant data sets, we used the Wilcoxon signed-rank test. We used the MATLAB Statistics Toolbox. This is a paired, two-sided test of the hypothesis that the difference between the matched samples (classification accuracies of the two methods across the 15 participants) comes from a distribution whose median is zero. The two-sided p-value is computed by doubling the most significant one-sided value. To report statistical significance of the findings, we applied the Bonferroni correction for multiple comparisons. The desired level of significance was divided by the number of comparisons  $10 * 9/2 = 45$  and only p-values under this level were reported as significantly different.

## 5.4 Rest versus game-play

The first set of experiments examined the possibility to recognise when the player is at rest (between levels) versus game play. Each data point in the record of each participant was labelled as REST/PLAY according to the stored timer values. The 8 features and the class labels were submitted to WEKA. The 10-fold cross-validation protocol was applied for each classifier method and each participant, thereby generating a table of estimated classification accuracies of size 15 rows (participants) by 10 columns (methods).

Table 5.2 shows the classification accuracies averaged across the 10 cross-validation folds. The column for the Largest Prior (LP) classifier is singled out because outperforming LP is the acid test for demonstrating the usefulness of the physiological signals, from the mouse. All classification methods were found to give statistically significant improvement over LP for *all* participants (two-tailed corrected t-test by WEKA,  $\alpha = 0.05$ ). The only exception was for participant # 9 (underlined in the table), where SVM and LP were on a par.

Arguably, mouse movements alone could be taken to discriminate between rest and game play. There are at least two reasons why the results reported here are of value.

First, the participants were not instructed to keep the mouse still out of game play, they were only asked to relax. Mouse movements might have occurred during the pause too.

Second, we did not take into account *any sequence* of points. Each time-point was taken to be an instance in the data set, so any correlation with time-neighbours is lost. The reported classification accuracy is calculated using the features extracted from a 10-second interval regardless of the previous or subsequent time points.



## 5.5 Event recognition

Table 5.2: Classification accuracies (in %) for the Rest/Play experiment.

Participant	LP	1nn	DT	RBF	MLP	SVM	Ada	Bag	RoF	RaF
1	60.79	80.45	78.61	65.08	72.20	63.48	63.36	81.76	80.87	83.17
2	59.93	75.45	77.23	67.39	72.80	66.31	67.39	77.19	79.32	77.66
3	58.52	78.70	81.12	77.61	80.69	78.27	76.97	83.94	83.35	84.95
4	59.11	83.37	84.83	81.54	85.94	81.41	84.93	86.67	86.65	87.37
5	58.34	75.65	73.04	71.11	74.30	69.58	68.08	77.43	77.64	77.79
6	59.61	75.73	74.61	65.27	71.30	65.53	71.14	78.44	75.58	79.02
7	58.56	80.84	80.18	71.88	75.89	74.86	73.79	82.28	78.27	82.38
8	60.45	78.88	75.55	71.00	74.14	70.72	71.28	80.82	78.44	81.71
9	62.89	78.49	76.67	72.10	76.47	<u>64.72</u>	71.54	80.69	80.80	81.82
10	57.39	80.18	83.42	71.48	79.45	73.26	76.03	85.05	81.88	84.17
11	58.57	75.16	77.01	64.97	70.83	63.13	63.10	80.37	77.09	81.54
12	59.07	71.12	71.00	66.90	70.89	67.72	69.29	74.28	74.67	73.97
13	57.99	76.80	78.63	71.61	78.05	60.75	68.87	80.97	80.87	81.04
14	59.72	78.75	74.53	73.59	77.68	74.14	75.00	77.94	78.42	78.09
15	59.59	84.11	83.59	73.24	83.19	73.11	78.54	85.36	82.26	85.97
Average	59.37	78.25	78.00	70.98	76.25	69.80	71.95	80.88	79.74	81.38

All methods showed statistically significant improvement, except underlined.

Largest Prior (LP), Nearest neighbour (1nn), Decision tree (DT), RBF Network (RBF), Multilayer Perceptron (MLP), SVM, AdaBoost (Ada), Bagging (Bag), Rotation Forest (RoF), Random Forest (RaF).

## 5.5 Event recognition

In the second set of experiments we looked at recognising game play *events* (see Table 4.3) versus *non-events*, using physiological signals.

For each participant we removed the non-played (REST) segments of data, so that only the game play data was analysed. We then extracted all unique values of EVENT and tallied their occurrences.

Detecting extremely rare events is very difficult because the data for the positive class (the event) is not sufficient for training a classifier. Hence, we chose the events with more frequent occurrences. For each event value of  $> 5000$  for each participant we created a binary vector. The events  $> 5000$  found for a 10 second window were 4, 288, 4160, 6144, 131072, as seen in Table 5.4 Bold and check marked  $\checkmark$ . For a 10 second window, these events were TEN\_SECOND\_TIMER\_BEEP, TOUCHED\_BALL

+ SCORED, TOUCHED\_ METEOR + LOSE\_ ENERGY, BUZZ + LOSE\_ ENERGY, ZAP.

In addition, all events relating to asteroid collisions were considered, even though they did not exceed the 5000 threshold. The hypothesis for this decision was that a participant may present a high emotive response to the large damage caused by striking asteroids. The column representing both asteroid and meteor strikes is shaded grey in Table 5.4.

Table 5.3 shows the results of the comparison of the chosen events for a 10 second window, using the Wilcoxon signed-rank test with Bonferroni correction.

The three columns for each event are compiled from a matrix of Win-Draw-Loss. For example, the LP classifier scored 0 wins, 1 draw (with itself) and 9 losses with regards to event TEN\_ SECOND\_ TIMER\_ BEEP (#4). This means that physiological data recorded through the mouse enabled any classifier mode to score better than chance and better than LP, thereby demonstrating the value of the device. On the other hand, the Random Forest ensemble classifier significantly outperformed all other methods (draw with itself) for 3 of the chosen events and all but one method for the remaining 3 events. This makes Random Forest a prime candidate for implementation in a closed-loop affective game play.

Table 5.3: Event comparisons using Wilcoxon signed-rank test with Bonferroni correction.

	W	D	L	W	D	L	W	D	L	W	D	L	W	D	L	W	D	L
Largest Prior	0	1	9	0	1	9	0	1	9	0	1	9	0	1	9	0	1	9
Nearest neighbour	5	4	1	5	4	1	5	4	1	5	4	1	5	4	1	5	4	1
Decision tree	4	4	2	4	4	2	4	4	2	4	4	2	4	4	2	4	4	2
RBF Network	1	4	5	1	4	5	1	4	5	1	4	5	1	4	5	1	4	5
Multilayer Perceptron	2	4	4	2	4	4	2	4	4	2	4	4	2	4	4	2	4	4
SVM	1	3	6	1	3	6	1	3	6	1	3	6	1	3	6	1	3	6
AdaBoost	1	4	5	1	4	5	1	4	5	1	4	5	1	4	5	1	4	5
Bagging	6	3	1	6	3	1	6	3	1	6	3	1	6	3	1	6	3	1
Rotation Forest	5	4	1	5	4	1	5	4	1	5	4	1	5	4	1	5	4	1
Random Forest	9	1	0	9	1	0	9	1	0	9	1	0	9	1	0	9	1	0
Ten Second Timer Beep Event # 4	W	D	L	W	D	L	W	D	L	W	D	L	W	D	L	W	D	L
Touched Ball + Scored Event # 288	0	1	9	0	1	9	0	1	9	0	1	9	0	1	9	0	1	9
Meteor + Energy Loss Event # 4160	0	7	3	0	7	3	0	7	3	0	7	3	0	7	3	0	7	3
Buzz + Energy Loss Event # 6144	0	4	6	0	4	6	0	4	6	0	4	6	0	4	6	0	4	6
Speed BUZZ Event # 131072	0	4	6	0	4	6	0	4	6	0	4	6	0	4	6	0	4	6
Asteroid Events All Related	0	3	7	0	3	7	0	3	7	0	3	7	0	3	7	0	3	7

W, D, L, Win, Draw, Lose respectively.

The same classification comparisons as described in section 5.3 were used. The Random Forest classifier ensemble performed well on all the *chosen* events, as seen underlined in all but one table of results in Appendix C. Even though these results showed a statistically significant improvement, the most important finding is event #4 (TEN\_SECOND\_TIMER\_BEEP) see Table 5.5 (full table in Appendix C). The most interesting finding is event TEN\_SECOND\_TIMER\_BEEP (#4). The reason is that all the other events could be recognisable to some extent by motion related artefacts. However, the 10 second timer beep has no connection to motion, as it simply was an audible *beep* indicator for the final 10 seconds of each level. Therefore the classification accuracies for this event were more reliable.

It was anticipated that collecting the target and scoring (EVENT 288) would yield detectable psychophysiological data, based on a reward based principle. However, even through the results accuracies were extremely high, we considered these could be an artefact of movement that was being detected. The average classification accuracy from all the 15 participants is seen in Table 5.6. The complete table of results for event 288 (TOUCHED\_BALL\_EVENT + SCORED\_EVENT) can be seen in Appendix C.

From these findings, we regard the detectable game motivator not to be the attainment of the highest score but rather the quest to avoid being hit and to stay alive. Many of the events, such as collecting the target, colliding with asteroids and meteors, and triggering the speed buzzer require movement.

## 5.6 Summary

To explore our hypothesis:

'Changes in a player's emotion can be recognised from psychophysi-

## 5.6 Summary

Table 5.4: Number of events and their respective number of occurrences, with >5000 highlighted bold and marked with ✓. Events related to Meteor (64) & Asteroid (128) strikes shaded grey. The × marks the individual corresponding events. The event's name key is given in Table 4.3.

Event	Occurred	1	2	4	8	16	32	64	128	256	512	1024	2048	4096	8092	16384	32768	65536	131072	>5000	
1	2152		×																		
2	1135			×																	
<b>4</b>	<b>10284</b>				×																✓
16	1248					×															
288	19123						×			×											✓
289	101	×					×			×											
290	10		×				×			×											
292	46			×			×			×											
296	10				×		×			×											
<b>4160</b>	<b>9813</b>							×						×							✓
4161	30	×						×						×							
4164	20			×				×						×							
4224	2352								×					×							
4225	30	×							×					×							
4240	11					×			×					×							
4448	10						×	×		×				×							
4512	10						×		×	×				×							
<b>6144</b>	<b>115021</b>												×	×							✓
6146	40		×										×	×							
6148	406			×									×	×							
6432	501						×			×			×	×							
8320	40								×						×						
8321	10	×							×						×						
8384	60							×	×						×						
10304	225							×					×		×						
10368	189								×				×		×						
10372	9			×					×				×		×						
12352	20							×						×	×						
12416	911								×					×	×						
12420	10			×					×					×	×						
12424	10				×				×					×	×						
14336	191												×	×	×						
16576	20							×	×							×					
16640	10									×						×					
18560	109								×				×			×					
98304	53																×	×			
<b>131072</b>	<b>52657</b>																		×		✓

## 5.6 Summary

Table 5.5: Classification accuracy % for EVENT\_4 TEN\_SECOND\_TIMER\_BEEP

Classifier	1nn	DT	RBF	MLP	SVM	Ada	Bag	Rof	Raf
Average	79.13	78.29	75.71	77.37	74.71	75.86	81.15	79.25	<u>82.19</u>

Table 5.6: Average classification accuracy % for EVENT\_288 – TOUCHED\_BALL\_EVENT + SCORED\_EVENT, with highest underlined.

Classifier	1nn	DT	RBF	MLP	SVM	Ada	Bag	Rof	Raf
Average	93.72	94.37	94.32	94.13	94.52	94.30	<u>94.95</u>	94.76	94.8

ological data using pattern recognition techniques, even when using crude data taken from an actively played affective video game’.

We used empirical methods to analyse the data, utilising several pattern recognition classifiers. Our analysis demonstrates that although possible, it is difficult to associate the expected affective responses with the physiological data gathered. This is because motion and affective signals can be hard to distinguish between. In addition, psychological aspects of seeking rewards (The Pleasure Principal) did not offer conclusive evidence as one might expect. For example, conditions that would logically merit an emotive reaction, such as being rewarded with points or responding to a menacing collision, offered very high classification accuracies. Even though these signals were strongly detected, objectively one has to question if the signal is motion or emotion related. Arguably, such high speed movement could be the cause of the detected change in signals.

However, one signal did offer the confidence that emotion was being detected; the ten second timer beep. The ten second timer beep was an audible signal to indicate that the level was nearing the end. Because it was recognised with high accuracy between all candidates, we believe that the signal was emotionally based.

## **5.6 Summary**

---

It is fair to suggest that all the signals could have been emotionally based. However, more research, particularly on the psychology, into this challenging area is required. Nevertheless, we conclude that our hypothesis was proven true, because an audible signal was clearly detected. And in turn, this demonstrates the useful function of the affective mouse.

# Chapter 6

## Conclusion

### 6.1 Summary of Work

The video games industry is mature and extremely advanced, particularly in the field of graphics. However, the area of dynamic realistic HCI emotive exchange, as seen in naturalistic communication, is lacking. Emotion is a significant part of natural interaction. Video game systems have little way of obtaining data to ascertain real changes in emotional states of a user, without special sensor equipment. This limits the video games ability to react to the player naturally.

Utilising affective data from moving physiological sensors is not a trivial task. In addition, the technology available to acquire affective gaming data is not commercially available. The affective video games industry is in its infancy and faces many challenges.

The technology for acquiring affective data has been in development for over four decades prior to the arrival of digital video games. The reasons for the lack of adoption of this technology is explored. We conclude that the investment into affective technologies have been superseded by the need to develop and advance graphical technologies. We advocate that graphical advancement will soon reach the limit of human



perception. Therefore, the need to improve realistic and dynamic human computer interactions, particularly in video games, will become a dominant focus.

To address the issue of the lack of available hardware, we take on the challenge of building an affective input device. We present an affective mouse that streams three physiological signals in real time, within an active video game. The system is aimed at offering a solution to affective game developers, researchers and the affective computing populous. The ergonomics and sensors of the device have been carefully considered to maximise signal clarity, while balancing interactive user comfort. The mouse requires no set-up or user preparation to use.

To test our hypothesis of producing an affective input device capable of streaming data while playing a video game, a bespoke video-game was developed. The video-game was successful in both highlighting the complexity of the signals, in relation to motion, and in stimulating mild levels of detectable emotive data. We successfully acquired psychophysiological data from the mouse during active gameplay. Our analyses demonstrate that the mouse can produce clean and usable psychophysiological signals in an active video game environment.

The mouse was built specifically using a rapid prototyping Stratasys Dimension Elite [129] 3D printer. The Dimension Elite system offers high quality robust and usable prototypes. The 3D assets (CAD) drawings will be offered freely to interested parties, under an open licence.

This approach to affective hardware creation and distribution could form a new evolution in advancing affective gaming hardware into independent (indie), mainstream video game development and serious game research. Wider possibilities are also envisaged, such as medical, marketing and defence applications, see section 6.2.

This work supports the hypothesis that:

*Creating robust, simple and easy to use hardware, capable of capturing and streaming key psychophysiological signals, from an active video game player in real time, is possible using new on-board micro controllers and carefully placed sensors.*

Physiological signals taken from low cost sensors offer utility in detecting changes in affect during active video game play. The electronic components could be utilised into any input device necessary, such as joy-pads, joysticks, etc. We advocate that this system and variants of it should be adopted by developers, gamers and researchers, to encourage and exploit active [AG](#) advancement.

It is noted that it is difficult to ascertain the emotive reaction of an individual to a particular stimulus using rudimentary means. Our analysis demonstrated that predicting a change in an emotive-state based on receiving a reward was indeterminate, thus highlighted the issues facing classical game design. The classification methods we used favoured ensemble classifiers over individual classifiers, for detecting emotive content from physiological sensors.

We believe that this contribution is important as a driving force to move affective gaming from the confines of large companies and into the hands of developers, gamers, researchers and enthusiasts, alike.

## 6.2 Future work

The next step would be to produce a video game that uses the affective gaming loop (Figure [2.1](#)).

We envisage that to enable psychophysiological data to be more effective in video games, personal psychophysiological user profiles may need to be considered. By establishing an individual's emotional responses over time, it may be possible to deter-

mine individual patterns of emotive reactions to specific stimuli; thus training a game to an individual. Profiling users affective states and reactions might prove invaluable for clearer recognition of emotion. Of course, this would raise ethical considerations, regarding how the data was stored and used, naturally. Based on the type or genre of game, affect could (amongst many other uses) be used to:

- Alter the course of a storyline.
- Change the games difficulty.
- Give or remove rewards.
- Halt or assist progression.

The list of changes that could be incorporated, to dynamically alter the course of a video game, is as vast as ones imagination. The fact that a video game could dynamically adjust, based upon the uniqueness of an individual, opens up a new frontier in video game design.

Additional applications could range from, but not limited to:

- Medical monitoring of *at risk* patients or vulnerable staff members. Watching their responses to different situations or workloads, respectively to avoid stress, anxiety, etc.
- Implementing new marketing methods, by monitoring user responses for new products, designs, packaging, usability, etc.
- Tracking working time, by recording the unique physiological patterns of a person actively using a system.

- Critical working guardian, assessing the stability of a worker under extreme/dangerous pressure (eg MOD bomb disposal).
- Early warning system, for events that effect emotion, such as sustaining an injury but being unable to physically respond.

With further trials, the aesthetics and usability of the mouse could potentially be further improved. More research is needed on real time analysis. Better alternatives to the FEZ mini (the digitiser) now exist, such as the FEZ Cerb40 II [45], being smaller (1.2”x0.6”) and faster (168mhz 32-bit Cortex-M4). Modular reflective photoplethysmograph sensors are also available, which could potentially obviate the use of the fin. Comparative trials would be necessary.

# Appendix A

## Signal Transmit Code

### A.1 FEZ domino/mini code (firmware)

---

```
using System;
using System.IO.Ports;
using System.Text;
using System.Threading;
using GHIElectronics.NETMF.FEZ;
using GHIElectronics.NETMF.Hardware;
using GHIElectronics.NETMF.IO;
using GHIElectronics.NETMF.System;
using Microsoft.SPOT;
using Microsoft.SPOT.Hardware;

namespace FEZtrial001
{
    public class Program
    {
        static int counter = 0;

        public static void MyThread()
        {
            Debug.Print("BEEP! ");

            Debug.Print("Starting thread");

            OutputPort LED = new
                OutputPort((Cpu.Pin)FEZ_Pin.Digital.LED, true);
```

## A.1 FEZ domino/mini code (firmware)

---

```
AnalogIn pinAn0 = new
    AnalogIn((AnalogIn.Pin)FEZ_Pin.AnalogIn.An0);
AnalogIn pinAn2 = new
    AnalogIn((AnalogIn.Pin)FEZ_Pin.AnalogIn.An2);

pinAn0.SetLinearScale(0, 3300); // scale to 3.3v
pinAn2.SetLinearScale(0, 3300); // scale to 3.3v

SerialPort UART = new SerialPort("COM2", 38400); // 115200

UART.ReadTimeout = 0; // consider removing to sync data?
UART.Open();

int RX_BYTE_LENGTH = 7;
byte[] buffer, rx_byte = new byte[RX_BYTE_LENGTH];

int read_rx, voltage1, voltage2, voltage3, voltage4,
    voltage0, i;
String counter_string, temperature = "", v0, v1, v2, v3,
    v4, v5;

// String counter_string;
while (true)
{
    UART.Flush();

    // reads temperature module through TX port
    read_rx = UART.Read(rx_byte, 0, RX_BYTE_LENGTH); // check
        bytes length

    //filter out carriage return from temp module
    for (i = 0; i < (rx_byte.Length); i = i + 1)
    {
        if ((char)rx_byte[i] == 13)
        {
            // convert C/return to ]
            temperature = temperature + "];";
        }
        else
        {
            // Build sting from chars
            temperature = temperature + (char)rx_byte[i];
        }
    }
}
```

```
    }
}
// An0 - Blood
voltage0 = pinAn0.Read();
v0 = voltage0.ToString();

// An2 - Pressure 1
voltage2 = pinAn2.Read();
v2 = voltage2.ToString();

// TX - Temperature
v5 = temperature;

// create string ready to send to RX port
counter_string = "[" + counter + ", " + v0 + ", " + v2 +
    ", " + v5 + "\n"; //Both

//counter_string = "BEEP "; // +v5;
buffer = Encoding.UTF8.GetBytes(counter_string);

UART.Write(buffer, 0, buffer.Length);

// stops counter going to high
if (counter > 20000)
{
    counter = 0;
}
counter++;
temperature = "";

Debug.Print("I am here!");
Debug.Print(counter_string);
counter_string = "";
}
}
public static void Main()
{
    // begins thread
    Thread ThreadHandler = new Thread(MyThread);
    ThreadHandler.Start();
}
}
} // end
```

---

## A.2 Matlab Code

---

```
%% Simple code that reads data from the UEXT port off the FEZ
    (Domino/Mini) it then plots the stored data

% the port (P) must be closed before an attempt to open it is
  made.
if exist('P', 'var')
    fclose(P)
end
%
close all ; clc ; clear all;

% creates a port at the correct rate
P = serial('COM16', 'BaudRate', 38400);

TIME = 1000; % run time in seconds

fopen(P);

disp('Port Open')
data = []; ep = [];
tic
disp('Data Recording Commenced')

while true; %toc < TIME
    c = clock;
    ep = [ep; c];

    payload = str2num(fgetl(P)); % fetches payload-data from
        device

    if numel(payload) == 7; % adds payload to array only if
        complete
        data = [data ; payload];
    end
    payload = ''; % clears payload at each iteration

end
toc

disp('End')
```



```
fclose(P) % closes port *** Must be done even if code crashes
disp('Port Closed')
temperature = data(:,7);

subplot(3,1,1); title('Pulse'); plot(data(:,2))
subplot(3,1,2); title('GSR');plot(data(:,4))
x = data(:,1);
t = data(:,7);
subplot(3, 1, 3);
title('Temperature');plot(x,t)

AMBER.clock = ep;
AMBER.data = data;
ti = fix(clock);
fname = ['AMBER_IEEE_TRIAL_1_' sprintf('%i_',ti(1:5))];
if TIME >= 60
    save(fname, 'AMBER');
    disp([fname ' saved'])
else
    disp('not saved');
end
```

---

# Appendix B

## Circuit Diagrams

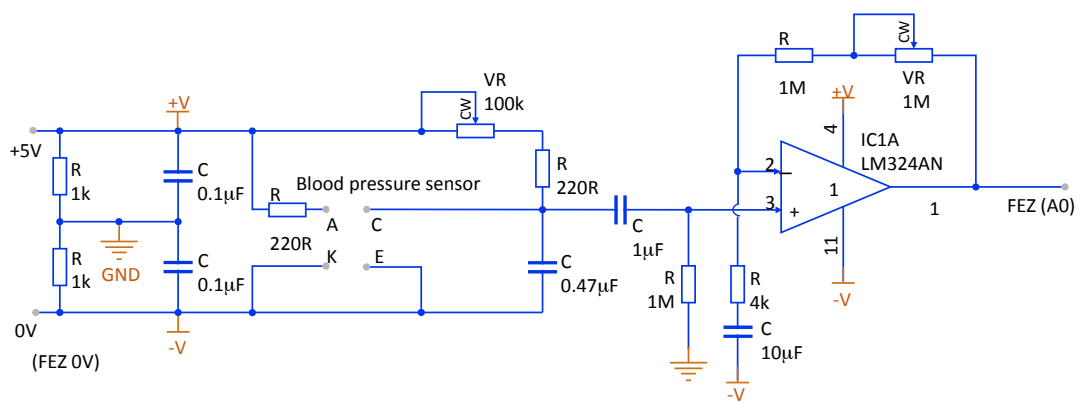

Figure B.1: Heart rate amplification and smoothing circuit diagram.

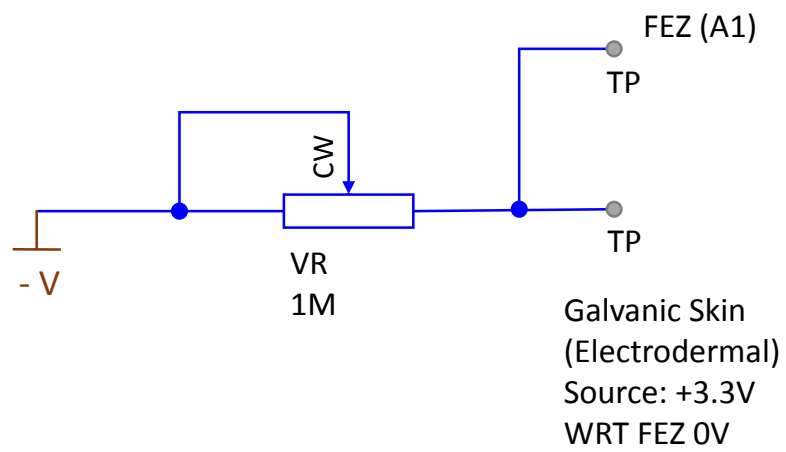

Figure B.2: Electrodermal circuit diagram.

# Appendix C

## Weka Output Result

### C.1 Result Tables

Table C.1: Classification accuracy % for EVENT\_4 – TEN\_SECOND\_TIMER\_BEEP

Participant	1nn	DT	RBF	MLP	SVM	Ada	Bag	Rof	Raf
1	78.34	78.50	75.27	78.35	71.80	70.49	78.18	79.42	80.06
2	73.63	75.10	73.93	73.48	73.40	72.99	79.41	75.54	79.57
3	82.59	82.27	76.90	81.48	77.36	76.06	84.40	83.85	86.33
4	78.01	79.45	75.82	77.04	76.13	79.09	82.81	78.86	83.41
5	82.73	80.13	78.13	80.84	77.67	77.44	81.41	81.99	81.85
6	83.56	79.94	78.67	79.46	74.93	77.13	82.76	83.24	84.26
7	78.07	76.64	77.50	77.33	77.48	77.69	82.86	79.01	83.19
8	78.96	79.86	77.22	76.39	76.86	76.98	83.10	78.98	83.67
9	80.52	83.02	74.28	81.12	76.45	81.12	85.10	84.16	86.99
10	74.94	76.31	72.24	73.45	71.84	73.62	80.89	74.51	81.18
11	74.47	72.94	72.78	74.54	72.87	74.34	77.67	73.16	78.64
12	80.36	77.03	77.33	76.67	67.94	72.43	80.36	81.20	81.01
13	81.33	77.48	73.94	74.55	73.20	74.67	78.65	77.40	81.06
14	73.98	73.95	72.93	72.44	73.30	73.10	75.93	73.76	76.24
15	85.45	81.71	78.68	83.37	79.49	80.77	83.78	83.60	85.33
Average	79.13	78.29	75.71	77.37	74.71	75.86	81.15	79.25	<u>82.19</u>

## C.1 Result Tables

Table C.2: Classification accuracy % for EVENT\_288 – (TOUCHED\_BALL\_EVENT + SCORED\_EVENT)

Participant	1nn	DT	RBF	MLP	SVM	Ada	Bag	Rof	Raf
1	99.04	99.41	98.90	99.41	99.41	99.41	99.41	99.41	99.37
2	86.16	84.66	85.18	86.32	84.76	84.17	87.88	87.14	88.31
3	98.90	99.26	99.05	99.26	99.26	99.01	99.26	99.26	99.26
4	93.66	95.09	95.66	95.36	95.81	95.64	95.79	95.81	95.14
5	87.48	89.23	89.98	89.55	90.34	90.12	90.26	90.28	89.57
6	92.79	95.99	95.94	94.98	95.99	95.94	95.99	95.99	95.63
7	98.52	98.61	98.30	98.17	98.70	98.57	98.70	98.70	98.46
8	87.31	90.62	87.85	87.41	88.27	87.29	91.38	88.87	92.26
9	91.82	91.94	91.82	91.57	91.84	91.69	92.35	92.29	93.00
10	96.20	96.15	96.20	95.92	96.58	96.13	96.58	96.58	96.60
11	96.47	97.62	97.52	97.08	97.62	97.62	97.62	97.62	97.27
12	96.03	97.64	97.27	97.27	97.68	97.68	97.68	97.66	97.50
13	99.77	99.63	99.63	99.77	99.63	99.98	99.63	99.63	99.89
14	99.56	99.08	99.08	99.05	99.08	99.16	99.08	99.08	99.08
15	82.10	80.67	82.49	80.86	82.85	82.03	82.57	83.12	81.66
Average	93.72	94.37	94.32	94.13	94.52	94.30	<u>94.95</u>	94.76	94.87

Table C.3: Classification accuracy % for EVENT\_4160 – (LOSE\_ENERGY\_EVENT + TOUCHED\_METEOR\_EVENT)

Participant	1nn	DT	RBF	MLP	SVM	Ada	Bag	Rof	Raf
1	90.77	92.01	90.38	91.29	90.14	89.55	90.26	91.56	90.85
2	68.23	72.22	69.92	67.41	70.03	70.75	76.57	71.43	77.20
3	79.84	80.17	81.26	79.74	80.57	80.19	83.76	81.39	85.17
4	70.34	74.83	58.65	67.34	55.39	67.46	77.87	71.34	78.23
5	77.08	75.87	76.15	76.41	75.89	76.21	77.60	76.53	78.86
6	82.31	83.11	79.56	80.70	79.63	78.59	84.04	83.57	84.39
7	81.64	83.89	79.56	81.58	77.81	77.87	87.16	83.60	87.59
8	72.61	71.10	61.12	67.33	65.04	63.18	75.71	72.04	77.47
9	76.03	73.72	65.98	72.09	67.17	65.83	79.18	75.81	79.89
10	95.72	95.90	96.46	95.90	96.14	96.14	96.05	96.12	96.31
11	90.05	89.74	90.25	89.76	90.31	90.72	90.73	90.37	92.03
12	92.35	92.73	93.31	92.57	91.36	91.24	93.29	93.74	93.76
13	91.31	90.52	91.20	89.89	91.53	91.07	91.72	91.51	91.95
14	74.54	75.35	73.62	70.99	70.95	72.32	75.89	74.45	76.77
15	77.24	69.74	67.69	70.71	67.48	70.08	75.88	71.81	77.12
Average	81.34	81.39	78.34	79.58	77.96	78.75	83.71	81.68	<u>84.51</u>

## C.1 Result Tables

Table C.4: Classification accuracy % for EVENT\_ 6144 – (BUZZ\_ EVENT + LOSE\_ ENERGY\_ EVENT)

Participant	Inn	DT	RBF	MLP	SVM	Ada	Bag	Rof	Raf
1	74.22	72.82	67.12	71.03	65.79	63.00	72.78	69.88	74.89
2	77.05	67.92	66.88	69.13	65.44	65.06	74.43	69.82	75.24
3	72.38	78.07	73.71	72.08	66.33	75.10	80.12	75.68	80.84
4	75.04	74.43	72.00	76.30	73.07	72.93	77.85	77.09	80.45
5	96.27	97.40	97.30	97.83	97.83	97.83	97.81	97.81	97.59
6	84.42	84.51	84.68	85.03	85.69	85.69	86.42	86.04	87.13
7	85.02	82.61	81.30	84.31	79.81	80.76	84.54	84.91	85.46
8	76.45	80.16	70.91	76.64	65.67	68.57	79.70	77.10	79.78
9	82.41	80.57	74.65	81.96	74.73	75.14	83.86	80.24	83.78
10	77.88	80.43	62.85	72.65	66.68	71.33	82.25	78.91	83.43
11	78.34	75.16	67.98	73.44	61.51	64.81	79.44	74.90	79.80
12	90.35	92.22	92.62	91.57	91.67	91.61	92.15	92.21	92.89
13	92.71	92.16	91.33	92.65	88.61	88.54	92.46	93.44	93.35
14	78.30	69.08	68.70	73.15	69.06	69.06	75.20	70.96	77.08
15	78.68	77.79	74.12	75.74	74.46	76.80	77.87	77.19	78.11
Average	81.30	80.36	76.41	79.57	75.09	76.42	82.46	80.41	<u>83.32</u>

Table C.5: Classification accuracy % for EVENT\_ 131072 – (ZAP\_ EVENT)

Participant	Inn	DT	RBF	MLP	SVM	Ada	Bag	Rof	Raf
1	76.82	78.72	73.62	77.43	74.36	74.18	81.32	81.10	82.42
2	74.47	75.18	69.67	71.31	69.27	71.93	75.31	74.93	75.53
3	95.00	95.28	95.66	95.68	96.07	95.98	96.01	96.09	96.27
4	77.70	78.99	71.32	78.68	69.17	74.83	79.97	80.84	81.87
5	71.80	69.64	70.01	75.04	66.35	69.45	73.19	74.13	73.81
6	76.96	75.38	70.59	74.43	67.18	72.98	77.07	77.77	79.16
7	86.85	81.61	80.87	81.19	80.56	80.48	83.17	81.91	84.93
8	80.14	79.02	75.36	78.11	73.13	73.55	80.39	76.60	80.96
9	73.78	79.71	72.53	72.47	73.27	72.84	79.92	74.35	80.61
10	81.67	78.71	76.32	79.68	73.66	75.74	80.92	79.80	82.61
11	84.00	86.48	82.40	82.88	82.54	84.25	85.91	83.74	86.46
12	93.16	93.22	93.90	93.55	93.99	93.99	94.15	94.15	94.40
13	78.36	82.63	80.85	79.87	77.78	76.63	81.92	82.05	81.99
14	92.68	88.51	87.48	90.06	86.56	87.15	89.69	89.62	90.78
15	73.00	66.71	62.63	65.55	64.14	62.91	71.29	69.17	71.48
Average	81.09	80.65	77.55	79.73	76.54	77.79	82.02	81.08	<u>82.89</u>

# Appendix D

## Code Highlights

### D.1 Code

The game mechanics were implemented through a movement vector object class, in Java; utilizing seek and flee principles set out by Craig Reynolds [114]. This involved 2 classes; `ParticleVector()` and `Movement()`

**Vectors** The `ParticleVector()` class formed the object (structure) for modifying and retrieving a coordinate point in 2 dimensional space. The template for the class member headings are as follows.

---

```
// Vector
public class Vector
{
// 2D vector representation
    private double x;
    private double y;

// class public accessors and mutators
    public void Vector()
    public void add() // add vector to x and y
    public void sub() // subtract vector to x and y
    public void multi(double n) // multiply vector x and y by n
    public void div(double n) // divide by n
    public float mag() // return the magnitude of x and y
    public void normalise() // unitise but keep direction
    public Vector get() // returns a copy vector x and y
    public Vector getX() // returns x
    public Vector getY() // returns y
}
```

---

**Particles** The Movement() class created multiple instances of ParticleVector() in relation to location, velocity, acceleration and friction. It also provided a method to update the movement and trajectory of these forces. The basic template structure for the Particle() class is as follows:

---

```
// Particle
public class Particle
{
    // define particle vectors
    Vector location;
    Vector velocity;
    Vector acceleration;
    Vector friction;
    Particle(Vector l) // initialise Particle
    public run(Graphics2D g2) // method to call update and
        display
    private update() // updates acceleration, velocity and
        forces
    private display(Graphics2D g2) // displays particle sprite
    private void checkEdges() // maintains edge collision
        behaviour
    public void applyForce() // applies forces (gravity, etc).
}
}
```

---

Several particle classes were created by extending the ParticleMovement() class, in a concept known as polymorphism. Polymorphism enables the methods of a parent class to be duplicated, whilst allowing the child class to change individual methods, to suit its needs accordingly. Below is a code snippet of class Asteroid extending the functionality of the class Particle. The *super* keyword calls the constructor method from the parent, thus instantiates an object from Particle, but re branded as type Asteroid.

---

```
Public class Asteroid extends Particle
{
    public Asteroid(Vector pv) // initialises Asteroid
    {
        super(pv); // calls Particle constructor
        ...
    }
}
```

---

Each new particle class provided the same particle control mechanisms (add(), sub(), div(), etc.) but each alters the movement behaviour and output graphic. Such that Meteors followed oscillating path lines and Asteroids utilised gravitational orbit forces.



This is a particularly useful technique as it allows the fluid motion of all the game assets, following the same motion principles of acceleration, velocity and friction.

The following Java classes were created: (asterisks \* indicate extended (polymorphism) classes)

---

```
ASprite() // generates a single sprite
AnimatedSprite() // returns the next sprite in a sequence
* Asteroid() // asteroid particle
* Background() // nebula movement sprite
BallSprite() // target animated sprite
* ChasingMeteor() // mouse following sprite
Feedback() // main executable class
* FireParticle() // orange meteor tail
* FlameParticle() // blue meteor tail
GameLevelParameterData() // game difficulty
GameNumber() // level number generator
Instructions() // instructions pause screen
LoadAudio() // loaded music and sound effects
LoadImages() // loaded all graphical sprites
Meteor() // instructions fixed meteor
MeteorSprites() // animated meteor
OSValidator() // OS detector (cross platform)
** Particle() // basic particle parent class
* ParticleConfetti() // Game Over celebrations
* ParticleSystem() // sparkling target dust
RockSprites() // instructions fixed Asteroid
Vector() // basic vector class
VectorRotation() // fast 90degree rotate algorithm
```

---

\*\* Parent Particle, \* Child Particle

**Multi-Thread** The game is run using five individual threads. The first thread is responsible for running the *Game Loop*. This is where the graphics are rendered and all gaming protocols are called, including collisions and particle emitters. The second is the mouse listener. This simply returns the coordinates of the mouse cursor and button positions. The third is the keyboard listener. The keyboard thread responded to keyboard inputs, such as have pausing and debugging tools. The mouse movement velocity counter was the fourth, triggering a method call every 100 milliseconds.

**Speed and Velocity** On each call, the distance the mouse had moved was calculated using:

$$v = \frac{d}{t} \quad (\text{D.1})$$

Where  $v$  is equal to distance  $d$  over time  $t$ . The distance is taken from the previous mouse coordinates and its current position.

However, we are interested in the movement speed and not the distance travelled. Therefore, we omit using the square root function in the Euclidean distance equation, using the squared Euclidean distance equation instead. This gives a good indication of the changes in mouse movement speed, even though it is not proportional to distance. The value is accumulated into a *Speedometer bar* variable and used to display speed bar indicator and to control the scoring speed zones.

In addition to speed, the coordinates are converted to a velocity vector. The velocity vector is used to determine the direction the mouse is travelling, when any collisions occur with an object. This velocity direction vector is then transferred to the colliding objects velocity vector, giving the illusion of an impact rebound.

---

```
//Java collision code

// for each particle child in sprite particles
for (Particle p : spriteParticles)
{
    // if they are meteors
    if(p instanceof Meteor)
    {
        // evoke meteor strike method
        touchedMeteorEvent(p);
    }
    ... // methods for each type of sprite follows
}

private void touchedMeteorEvent(Particle p)
{
    // add event to game state data
    addEvent(TOUCHED_METEOR_EVENT);
    playSound(RASP);
    decreaseEnergyBar(ENERGY_BAR_ROCK_DAMAGE, 50);

    // get the direction and magnitude if mouse pointer (ship)
    mouseDirection = getMouseVectorDirection();

    // jolt mouse cursor
```

```
PVector mouseMoved = PVector.add(mouseDirection.location,
    p.velocity);
robot.mouseMove((int) mouseMoved.x, (int) mouseMoved.y);

    // make sure mouse has magnitude
if (mouseDirection.velocity.mag() > 1)
{
    // transfer mouse velocity to meteor p
    p.velocity.equals(mouseDirection.velocity);
} else
{
    // if no mouse velocity, reverse direction of meteor p
    playSound(BOMB);
    p.velocity.multi(-1);
}
}
```

---

**Orbital Rotation (Force)** To rotate the asteroids around the target, we applied the forces to the particle vector. The first was an attraction force and the second was a rotation force and the third was forward velocity. This technique formed an orbital behaviour, which made avoiding the asteroid and collecting the target more challenging.

The attraction force simply added a reversed acceleration force to the asteroids velocity vector, in the direction of the target. Then we flipped the x and y coordinates of the asteroid velocity vector, so that  $x = -y$  and  $y = x$ . This rotated the asteroid velocity vector by  $90^\circ$  clockwise. Coupled with a continuous velocity (forward) motion, this completed the orbital motion vector technique.

The following algorithm sequence was followed:

- A new vector is created, from the target to the moving asteroid
- The vector is normalised by dividing x and y by the magnitude  $\frac{x}{\sqrt{x^2+y^2}}$  and  $\frac{y}{\sqrt{x^2+y^2}}$
- Then multiplied by an arbitrary value, based on a desired orbital distance.
- The vector is rotated by  $90^\circ$  using :

---

```
// quick 90 degree vector rotation
double y = this.x; // temp y = x
double x = -this.y; // temp x = -y (negative y)
this.equals(x, y); // velocity equals temp values.
```

---

- And repeat...

In short, the asteroid velocity direction is continually altered to be at  $90^\circ$  to the target. The distance of from the target (orbital distance) is anchored using a fixed value; normalised and multiplied. The continuous motion of the asteroid and the *quick*  $90^\circ$  rotating of its direction of trajectory formed an orbital rotation effect, as depicted in Figure D.1.

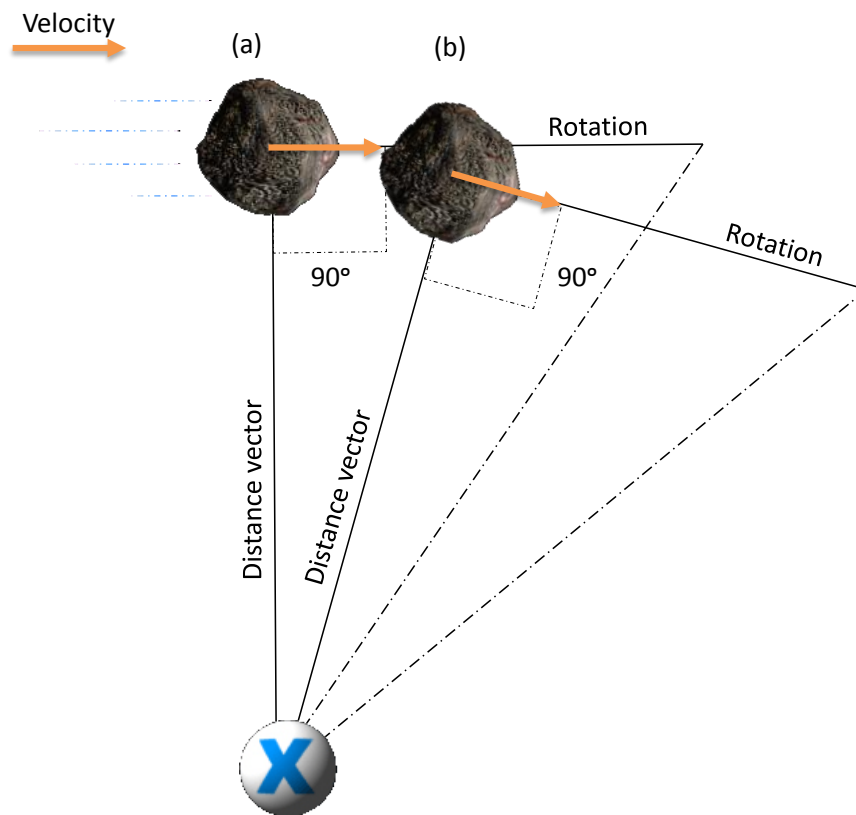

Figure D.1: Depiction of the motion when implementing the Cartesian rotation algorithm.

**Particle Emitter** The vector and motion classes were also used for video-game-effects, such as particle emitters. Particle emitters are algorithms that create a large number of Cartesian coordinate values, with various motion attributes, such as velocity, acceleration, gravity and other forces. Particle emitters were used for effects attributed to collisions, scoring, energy loss, etc.

## References

- [1] .NET Micro Framework. <http://www.netmf.com/>, 2011. Last accessed February 2015. 27
- [2] J. V. Aart, E. R. G. Klaver, C. Bartneck, L. M. G. Feijs, and P. J. F. Peters. Enabling Easy Use in the Home Environment. *Signals*, pages 23–30, 2008. 11
- [3] M. Ambinder. Valve’s approach to playtesting: The application of empiricism. In *Game Developers Conference*, 2009. 22
- [4] M. Ambinder. Biofeedback in gameplay: How valve measures physiology to enhance gaming experience. In *Game Developers Conference*, 2011. 22, 27, 33
- [5] American Broadcasting Company (ABC). The chair (game show). [http://en.wikipedia.org/wiki/The\\_Chair\\_game\\_show](http://en.wikipedia.org/wiki/The_Chair_game_show), 2002. Last accessed February 2015. 22
- [6] Amtex. Tetris 64. Seta Corporation, November 1998. 31
- [7] P. Bacchini, J. Ferreira, and T. Marcelo. Emopad: An affective gamepad. *International Journal of Computer Applications*, 2014. 33
- [8] C. Becker, A. Nakasone, H. Prendinger, M. Ishizuka, and I. Wachsmuth. Physiologically interactive gaming with the 3D agent Max. In *International Workshop on Conversational Informatics at JSAI*, volume 5. Citeseer, 2005. 33
- [9] D. Bersak, G. McDarby, N. Augenblick, P. McDarby, D. McDonnell, B. McDonald, and R. Karkun. Intelligent biofeedback using an immersive competitive environment. *Designing Ubiquitous Computing Games Workshop*, 2001. 29, 33
- [10] BIOPAC Systems, Inc. BIOPAC. <http://www.biopac.com/psychophysiology>, 2015. Last accessed February 2015. 25
- [11] Blue Sea Systems (BSS) Electrical Systems. Electrical conductivity of materials. [https://www.blueseasystems.com/resources/108/Electrical\\_Conductivity\\_of\\_Materials](https://www.blueseasystems.com/resources/108/Electrical_Conductivity_of_Materials), September 2014. Last accessed September 2014. 57

- 
- [12] F. Boiten. The effects of emotional behaviour on components of the respiratory cycle. *Biological Psychology*, 49(1-2):29–51, 1998. 22
- [13] A. Bonarini, F. Costa, M. Garbarino, M. Matteucci, M. Romero, and S. Tognetti. Affective videogames: The problem of wearability and comfort. *SpringerLink: Human-Computer Interaction. Users and Applications*, 6764:649–658, 2011. 22, 23, 25, 27, 33, 53, 55, 59
- [14] D. O. Bos. EEG-based emotion recognition. <http://emi.uwi.utwente.nl/verslagen/capita-selecta/CS-oudeBos-Danny.pdf>, 2006. Last accessed January 2014. 20, 21
- [15] E. Brown and P. Cairns. A grounded investigation of immersion in games. *Extended abstracts of the 2004 conference on Human factors and computing systems CHI 04*, computings:1297, 2004. 38
- [16] R. Calvo, I. Brown, and S. Scheduling. Effect of experimental factors on the recognition of affective mental states through physiological measures. *AI 2009: Advances in Artificial Intelligence*, pages 62–70, 2009. 10
- [17] R. Calvo and S. DMello. Affect detection: An interdisciplinary review of models, methods, and their applications. *IEEE Transactions on Affective Computing*, 1(1):18–37, 2010. 10, 13
- [18] CAPCOM. Resident evil. <http://www.residentevil.com>, 1996. Last accessed February 2015. 96
- [19] G. Chanel, J. Kronegg, D. Grandjean, and T. Pun. Emotion assessment: Arousal evaluation using EEGs and peripheral physiological signals. *Multimedia Content Representation, Classification and Security*, pages 530–537, 2006. 14
- [20] G. Chanel, C. Rebetez, M. Bétrancourt, and T. Pun. Boredom, engagement and anxiety as indicators for adaptation to difficulty in games. In *Proceedings of the 12th international conference on Entertainment and media in the ubiquitous era*, pages 13–17. ACM, 2008. 33, 55
- [21] T. Chisty and L. Kuncheva. A.M.B.E.R. Shark-Fin: An Unobtrusive Affective Mouse. In *ACHI 2013: The Sixth International Conference on Advances in Computer-Human Interactions*, pages 488–495, 2013. 12, 14, 27, 33, 75
- [22] T. Christy and L. I. Kuncheva. Advancements in practical and theoretical affective gaming : A historical survey. *GSTF Journal on Computer Games and Multimedia (JCGM)*, 1, 2014. 9, 22

## REFERENCES

---

- [23] T. Christy and L. I. Kuncheva. Advancements in practical and theoretical affective gaming : A historical survey. *GSTF International Journal on Computing (JoC)*, 3, 2014. 22
- [24] J. Copeland. *Colossus: The First Electronic Computer (Popular Science)*. Oxford University Press, USA, 1 edition, May 2006. 30
- [25] C. Darwin. *The Expression of the Emotions in Man and Animals*. John Murray, 1872. 1, 8
- [26] A. Dekker and E. Champion. Please biofeed the zombies: enhancing the gameplay and display of a horror game using biofeedback. *Proc. of DiGRA*, pages 550–558, 2007. 22, 30, 33
- [27] D. Douglas. Psychogalvanometer, April 1958. (patent) US2829638 A. 24
- [28] A. Drachen and A. L. Pedersen. Correlation between heart rate, electrodermal activity and player experience in first-person shooter games. *Heart*, pages 49–54, 2009. 33
- [29] P. Ekman, W. Friesen, M. O’Sullivan, A. Chan, I. Diacoyanni-Tarlatzis, K. Heider, R. Krause, W. LeCompte, T. Pitcairn, P. Ricci-Bitti, et al. Universals and cultural differences in the judgments of facial expressions of emotion. *Journal of Personality and Social Psychology*, 53(4):712, 1987. 15
- [30] G. Electronics. Fez domino. <https://www.ghielectronics.com/catalog/product/133>, September 2014. Last accessed 20th September 2014. 49
- [31] D. Emmen and Lampropoulos. Biopong: Adaptive gaming using biofeedback. In *Proceedings of the Chi Sparks Conference*, pages 100–103, 2014. 27, 33
- [32] Emotiv. EPOC+. <http://emotiv.com>, 2014. Last accessed February 2015. 21
- [33] (ESA). Essential facts about the computer and video game industry. [http://www.theesa.com/facts/pdfs/ESA\\_EF\\_2013.pdf](http://www.theesa.com/facts/pdfs/ESA_EF_2013.pdf), 2013. Last accessed 11 September 2013. 1, 9, 40
- [34] Extreme Tech. Forcewear vest. In *Game Developers Conference*, <http://www.extremetech.com/gaming/77332-gaming-is-everywhere-gdc-2007/3>, 2007. Last accessed February 2015. 23
- [35] S. Fairclough. Fundamentals of physiological computing. *Interacting with Computers*, 21(1-2):133–145, 2008. 12, 13, 27

## REFERENCES

---

- [36] C. Fisher and P. Sanderson. Exploratory sequential data analysis: exploring continuous observational data. *Interactions*, pages 25–34, 1996. 17
- [37] B. Francesco, B. Kapralos, K. Lee, P. Moreno-Ger, and R. Berta. Assessment in and of serious games: An overview. *Advances in Human-Computer Interaction*, 2013:11, 2013. 71
- [38] B. Fulton. Beyond Psychological Theory: Getting Data that Improves Games. In *Gamasutra*, 2002. 17
- [39] Future Technology Devices International Ltd. TTL USB to serial converter TTL-232R-3V3-PCB. <http://www.ftdichip.com/Products/Cables/USBTTLSerial.htm>, September 2014. Last accessed September 2014. 49
- [40] A. Gaggioli. Mantra mouse. <http://gaggio.blogspirit.com/archive/2006/03/27/mantra-mouse.html>, March 2006. last accessed 9 April 2013. 31, 37
- [41] N. Genes. We're Not Lying About Galvanic Skin Response. [http://www.medgadget.com/2006/03/were\\_not\\_lying.html](http://www.medgadget.com/2006/03/were_not_lying.html), March 2006. Last accessed April 2013. 31
- [42] M. Gerven, J. Farquhar, R. Schaefer, R. Vlek, J. Geuze, A. Nijholt, N. Ramsey, P. Haselager, L. Vuurpijl, S. Gielen, and P. Desain. The brain-computer interface cycle. *Journal of Neural Engineering*, 6:041001, 2009. 20
- [43] GHI Electronics. Fez micro-controllers. <https://www.ghielectronics.com/>, 2010. Last accessed February 2015. 27
- [44] GHI Electronics. FEZ mini board. [http://www.ghielectronics.com/downloads/FEZ/Mini/Broch\\_FEZ\\_Mini.pdf](http://www.ghielectronics.com/downloads/FEZ/Mini/Broch_FEZ_Mini.pdf), 2012. Last accessed February 2015. 50
- [45] GHI Electronics. FEZ Cerb40 II. <https://www.ghielectronics.com/catalog/product/450>, 2015. Last accessed February 2015. 113
- [46] K. Gilleade and J. Allanson. A Toolkit for Exploring Affective Interface Adaptation in Videogames Developing an Affective Videogame. *Proceedings of HCI International*, 2:370—374, 2003. 33
- [47] J. Golseth and C. LeGrand. Electronic diagnostic instruments, July 1955. (patent) US2712975 A. 24



## REFERENCES

---

- [48] H. Gunes, B. Schuller, M. Pantic, and R. Cowie. Emotion representation, analysis and synthesis in continuous space: A survey. In *IEEE International Conference on Automatic Face Gesture Recognition and Workshops.*, pages 827–834, 2011. 10
- [49] M. Hall, E. Frank, G. Holmes, B. Pfahringer, P. Reutemann, and I. Witten. The WEKA data mining software: An update. *SIGKDD Explorations*, 11, 2009. 97
- [50] S. R. Hathaway. Apparatus for measuring psychogalvanic responses, Jan 1930. (patent) US1761476 A. 24
- [51] J. Healey. *Wearable and Automotive Systems for Affect Recognition from Physiology*. PhD thesis, Massachusetts Institute of Technology, Dept. of Electrical Engineering and Computer Science, 2000. 25
- [52] W. Holzer and A. Marko. Arrangement for recording variations in the electrical resistance of the human body, January 1953. (patent) US2661734 A. 24
- [53] Y. Homma, I. Masaoka. Breathing rhythms and emotions. *Experimental physiology*, 93:1011–1021, 2008. 22
- [54] E. Hudlicka. Affective game engines: motivation and requirements. In *Proceedings of the 4th International Conference on Foundations of Digital Games*, pages 299–306. ACM, 2009. 11
- [55] IMDb. Most popular video games released in 1983. [http://www.imdb.com/search/title?sort=moviemeter&title\\_type=game&year=1983,1983](http://www.imdb.com/search/title?sort=moviemeter&title_type=game&year=1983,1983), 2015. Last Accessed February 2015. 37
- [56] IMDb. Most popular video games released in 1984. [http://www.imdb.com/search/title?sort=moviemeter&title\\_type=game&year=1984,1984](http://www.imdb.com/search/title?sort=moviemeter&title_type=game&year=1984,1984), 2015. Last accessed February 2015. 37
- [57] IMDb. Most popular video games released in 1987. [http://www.imdb.com/search/title?sort=moviemeter&title\\_type=game&year=1987,1987](http://www.imdb.com/search/title?sort=moviemeter&title_type=game&year=1987,1987), 2015. Last accessed February 2015. 37
- [58] IMDb. Most popular video games released in 1998. [http://www.imdb.com/search/title?sort=moviemeter&title\\_type=game&year=1998,1998](http://www.imdb.com/search/title?sort=moviemeter&title_type=game&year=1998,1998), 2015. Last accessed February 2015. 37
- [59] W. James. Mind association what is an emotion ? *Oxford University Presson behalf of the Mind Association*, 9:188–205, 1884. 1, 8, 10

## REFERENCES

---

- [60] C. Jennett, A. Cox, P. Cairns, S. Dhoparee, A. Epps, and A. Tijs, T. Waltson. Measuring and defining the experience of immersion in games. *International Journal of Human-Computer Studies*, 66:641–661, 2008. 33, 38
- [61] C. Jones and A. Deeming. Affective human-robotic interaction. *Affect and Emotion in Human-Computer Interaction*, pages 175–185, 2008. 17
- [62] C. Jones and J. Sutherland. Acoustic emotion recognition for affective computer gaming. *Affect and emotion in human-computer interaction: from theory to applications*, 4868:209, 2008. 15, 33
- [63] Z. Kaplan. Wii vitality sensor never released because it was 'insufficient as a commercial product'. <http://www.nintendoworldreport.com/news/34865>, 2013. Last accessed July 2013. 38
- [64] A. Kappas. Smile when you read this, whether you like it or not: conceptual challenges to affect detection. *Affective Computing, IEEE*, 1(1):38–41, 2010. 13, 14
- [65] Kickstarter - MIONIXLABS. Quantified gaming - know more, game better. <https://www.kickstarter.com/projects/206180815/quantified-gaming-know-more-game-better>, 2015. Last accessed February 2015. 40
- [66] J. Kivikangas, I. Ekman, and G. Chanel. Review on psychophysiological methods in game research. *Proc. of 1st Nordic DiGRA*, 2010. 25
- [67] K. Ko, H. Yang, and K. Sim. Emotion recognition using EEG signals with relative power values and Bayesian network. *International Journal of Control, Automation and Systems*, 7(5):865–870, Oct. 2009. 20
- [68] R. Koller. Cardio-pneumo-electrodermograph, March 1953. (patent) US2657683 A. 24
- [69] Konami Corporation. Tokimeki memorial oshiete your heart. Konami Digital Entertainment Inc, 1997. 31
- [70] E. Konstantinidis, C. Frantzidis, C. Papadelis, C. Pappas, and P. Bamidis. Waded: A wearable affective device with on-chip signal processing capabilities for measuring electrodermal activity. *XII Mediterranean Conference on Medical and Biological Engineering and Computing*, pages 276–279, 2010. 25
- [71] S. Kreibig. Autonomic nervous system activity in emotion: a review. *Biological psychology*, 84:394–421, 2010. 77

## REFERENCES

---

- [72] K. Kuikkaniemi, I. Kosunen, M. Turpeinen, T. Saari, T. Laitinen, and P. Lieevonen. Designing Biofeedback for Games and Playful Applications. In *CHI 2010*, 2010. 33
- [73] L. Kuncheva. Matlab affectivetoolbox version 3. Bangor University, 2013. 91
- [74] L. Kuncheva, T. Christy, I. Pierce, and S. Mansoor. Multi-modal biometric emotion recognition using classifier ensembles. *Modern Approaches in Applied Intelligence*, pages 317–326, 2011. 51
- [75] W. Liao, W. Zhang, Z. Zhu, Q. Ji, and W. D. Gray. Towards a decision-theoretic framework for affect recognition and user assistance. *International Journal of Man-Machine Studies*, 64(9):847–873, 2006. 14
- [76] C. Liu, P. Agrawal, N. Sarkar, and S. Chen. Dynamic difficulty adjustment in computer games through real-time anxiety-based affective feedback. *International Journal of Human-Computer Interaction*, 25:506–529, 2009. 33, 55
- [77] R. Mandryk and M. Atkins. A fuzzy physiological approach for continuously modeling emotion during interaction with play technologies. *International Journal of Human-Computer Studies*, 65:329–347, 2007. 33
- [78] R. Mandryk and K. Inkpen. Physiological indicators for the evaluation of co-located collaborative play. In *Proceedings of the 2004 ACM conference on Computer supported cooperative work - CSCW '04*, pages 102—112, 2004. 27
- [79] Maplin. Pulse rate monitor kit. <http://www.maplin.co.uk/p/pulse-rate-monitor-kit-n56f1>, September 2014. Last accessed September 2014. 48
- [80] V. Mathison. Electropsychometer or bioelectronic instrument [v1], July 1954. (patent) US2736313 A. 24
- [81] V. Mathison. Electropsychometer or bioelectronic instrument [v2], February 1956. (patent) US2799269 A. 24
- [82] I. Mauss and M. Robinson. Measures of emotion: A review. *Cognition & Emotion*, 23(2):209–237, 2009. 13
- [83] S. McQuiggan, S. Lee, and J. Lester. Predicting user physiological response for interactive environments: An inductive approach. *2nd Artificial Intelligence for Interactive*, 2006. 33
- [84] M.D. van der Zwaag, E.L. van den Broek, and J. Janssen. Guidelines for biosignal-driven HCI. *CHI 2010*, April 2010. 14

## REFERENCES

---

- [85] Melexis Microelectronics Integrated System. Digital, plug & play, infrared thermometer. <http://www.melexis.com/Infrared-Thermometer-Sensors/MLX90614-615.aspx>, 2015. Last accessed February 2015. 46
- [86] Middlesex University Teaching Resources. Pulse rate monitor. <http://www.mutr.co.uk>, 2011. Last accessed May 2011. 46
- [87] D. Milne, J. Fagarty, and J. Duxlevie. Psychometer, January 1944. (patent) US2339579 A. 24
- [88] B. Mittelman and H. Wolff. Effective states and skin temperature: experimental study of subjects with "cold hands" and raynaud's syndrome. *Psychosomatic Medicine*, 1:271–292, 1939. 23
- [89] B. Mittelman and H. Wolff. Emotions and skin temperature; observations of patients during psychotherapeutic (psychoanalytic) interviews. *Psychosomatic Medicine*, 5(3):211–231, 1943. 23
- [90] MONIXLABS. NAOS QG quantified gaming mouse. <http://mionix.net/concepts/naos-qg/>, 2015. Last accessed February 2015. 40
- [91] L. Nacke. *Affective Ludology: Scientific measurement of user experience in interactive entertainment*. PhD thesis, School of Computing Blekinge Institute of Technology, 2009. 33
- [92] C. Nadeau and Y. Bengio. Inference for the generalization error. *Machine Learning*, 62:239–281, 2003. 100
- [93] Neurosky. Mindset. <http://store.neurosky.com/products/mindset>, 2009. Last visited February 2015. 20, 51
- [94] Neurosky. Mindwave. <http://store.neurosky.com/products/mindwave-1>, 2011. Last accessed February 2015. 20
- [95] M. Nichol. 100 words for facial expressions. <http://www.dailywritingtips.com/100-words-for-facial-expressions/>, 2012. Last accessed February 2015. 17
- [96] M. Nicolaou, H. Gunes, and M. Pantic. Continuous prediction of spontaneous affect from multiple cues and modalities in valence-arousal space. *IEEE Transactions on Affective Computing*, 2(2):92 – 105, 2011. 14
- [97] A. Norman. *Emotional Design: Why We Love (or Hate) Everyday Things*. Basic Books, 2003. 8

## REFERENCES

---

- [98] OCZ Technology. Neural impulse actuator. <http://www.ocztechnology.com/nia-game-controller.html>, 2011. Last accessed April 2011. 20
- [99] U. of Waikato. Weka data mining software in java. <http://www.cs.waikato.ac.nz/ml/weka/>, 1997. Last accessed February 2015. 97
- [100] R. Pagulayan, K. Keeker, D. Wixon, R. Romero, and T. Fuller. User-centered design in games. *The human-computer interaction handbook: fundamentals, evolving technologies and emerging applications*, pages 883–906, 2003. 9
- [101] B. R. Payne. Audible psychogalvanometer, March 1972. (patent) US3648686 A. 24
- [102] P. Petrantonakis and L. Hadjileontiadis. Emotion recognition from EEG using higher-order crossings. *IEEE Transactions on Information Technology in Biomedicine*, 14(2):186–197, 2010. 14
- [103] R. Picard. *Affective computing*. The MIT press, 2000. 1, 8, 21
- [104] R. Picard. Affective computing: challenges. *International Journal of Human-Computer Studies*, 59(1-2):55–64, 2003. 10
- [105] R. Picard. Emotion research by the people, for the people. *Emotion Review*, 2(3):250, June 2010. 9, 10, 12, 14, 27
- [106] R. Picard and J. Healey. Affective wearables. *Personal Technologies*, 1:231–240, 1997. 10.1007/BF01682026. 8, 14, 18, 23, 25
- [107] R. Picard, E. Vyzas, and J. Healey. Toward machine emotional intelligence: analysis of affective physiological state. *IEEE Transactions on Pattern Analysis and Machine Intelligence*, 23(10):1175–1191, 2001. 29
- [108] S. Poole. Trigger happy: Videogames and the entertainment revolution. Web Download Edition, 2007. Last accessed 11 September 2013. 30
- [109] P. Pour, T. Gulrez, O. AlZoubi, G. Gargiulo, and R. Calvo. Brain-computer interface: Next generation thought controlled distributed video game development platform. *IEEE Symposium On Computational Intelligence and Games*, pages 251–257, 2008. 33
- [110] J. Raesler, C. Bills, and C. Osborne. Psychogalvanometer, January 1943. (patent) US2308933 A. 24
- [111] P. Rani, N. Sarker, and C. Liu. Maintaining Optimal Challenge in Computer Games through Real-Time Physiological Feedback Mechanical Engineering. *Pulse*, 2005. 17, 33, 55

## REFERENCES

---

- [112] N. Ravaja, T. Saari, M. Salminen, J. Laarni, and K. Kallinen. Phasic Emotional Reactions to Video Game Events: A Psychophysiological Investigation. *Media Psychology*, 8(4):343–367, 2006. [33](#)
- [113] N. Ravaja, M. Turpeinen, T. Saari, S. Puttonen, and L. Keltikangas-Järvinen. The psychophysiology of James Bond: phasic emotional responses to violent video game events. *Emotion*, 8(1):114–120, 2008. [33](#)
- [114] C. Reynolds. Steering behaviors for autonomous characters. In *Game Developers Conference*, pages 763–782. Miller Freeman Game Group, San Francisco, California, 1999. Last accessed 02 July 2014. [33](#), [124](#)
- [115] C. Reynolds. *The sensing and measurement of frustration with computers*. PhD thesis, Massachusetts Institute of Technology, 2001. [9](#), [26](#), [29](#), [47](#), [59](#)
- [116] J. A. Russell. A circumplex model of affect. *Journal of personality and social psychology*, 39(6):1161, 1980. [10](#)
- [117] J. Ryan. Toy lie detector, March 1964. (patent) US3127176 A. [24](#)
- [118] T. Saari, N. Ravaja, J. Laarni, and M. Turpeinen. Towards Emotionally Adapted Games based on User Controlled Emotion Knobs. *Human Factors*, 2005. [33](#)
- [119] S. Schachter and J. Singer. Cognitive, social and physiological determinantws of emotional state. *Psychological review*, 69(5):379–399, 1962. [10](#)
- [120] J. Scheirer, R. Fernandez, J. Klein, and R. Picard. Frustrating the user on purpose: a step toward building an affective computer. *Interacting with Computers*, 14(2):93–118, 2002. [14](#), [23](#), [33](#)
- [121] E. Schrawzkopf and G. Wodtke. Electrocardiograph, August 1928. (Patent) US1681628 A. [24](#)
- [122] K. Shelley, A. Jablonka, D.H.and Awad, R. Stout, H. Rezkanna, and D. Silverman. What is the best site for measuring the effect of ventilation on the pulse oximeter waveform? *Anesthesia and analgesia*, 103:372–377, 2006. [59](#)
- [123] K. Shelley and S. Shelley. *Pulse oximeter waveform: photoelectric plethysmography*. W.B. Saunders, 2001. [22](#), [45](#), [46](#)
- [124] J. Sherwood and R. Derakhshani. On classifiability of wavelet features for EEG-based brain-computer interfaces. *2009 International Joint Conference on Neural Networks*, pages 2895–2902, June 2009. [20](#)

## REFERENCES

---

- [125] Silicon Graphics Inc. Open graphics library. <https://www.opengl.org/>, 1991. Last accessed February 2015. 38
- [126] G. Singer. The history of the modern graphics processor. <http://www.techspot.com/article/650-history-of-the-gpu/>, 2014. Last accessed February 2013. 39
- [127] T. Sottek. How valve’s steam box will reinvent the game console as you know it. TheVerge.com, February 2013. last accessed 7th February 2013. 40
- [128] R. Stern, W. Ray, and K. Quigley. *Psychophysiological Recording*. Oxford university press, second edition, 2001. 21, 45, 94
- [129] Stratasys. Dimension elite. <http://www.stratasys.com/3d-printers/design-series/dimension-elite>, 2015. Last accessed February 2015. 110
- [130] J. Sykes and S. Brown. Affective gaming. *CHI 03 extended abstracts on Human factors in computing systems CHI 03*, page 732, 2003. 33, 94, 97
- [131] M. Takagi. Instrument for locating particular cutaneous points caused by viscerovascular reflex, September 1965. (patent) US3207151 A. 24
- [132] K. Takahashi. Remarks on emotion recognition from bio-potential signals. In *The Second International Conference on Autonomous Robots and Agents*, pages 186–191. Citeseer, 2004. 20
- [133] ThalmicLabs. MYO Gesture Control Armband. <https://www.thalmic.com/en/myo/>, 2015. Last accessed February 2015. 40
- [134] The Economist. *Nintendo wakes up*. The Economist Magazine, August 1996. 38
- [135] Thought Technology Ltd. Calmpute. <http://www.thoughttechnology.com/blog/wp/?works=calmpute>, 2015. Last accessed February 2015. 27
- [136] T. Tijs, D. Brokken, and W. Ijsselsteijn. Dynamic game balancing by recognizing affect. In *Proceedings of the 2nd International Conference on Fun and Games.*, pages 88–93, 2008. 30, 33
- [137] S. Tognetti, M. Garbarino, A. Bonarini, and M. Matteucci. Modeling enjoyment preference from physiological responses in a car racing game. *Computational Intelligence and Games (CIG)*, pages 321–328, 2010. 23, 33
- [138] H. Tygart. System for fm transmission of cardiological data over telephone lines, February 1969. (patent) US3426150 A. 24

## REFERENCES

---

- [139] Valve Corporation. Left for dead. <http://www.14d.com>, 2008. Last accessed 2015. 96
- [140] W. Van Den Hoogen, W. IJsselsteijn, and Y. De Kort. Effects of Sensory Immersion on Behavioural Indicators of Player Experience: Movement Synchrony and Controller Pressure. *digraorg*, 2009. 33, 94, 97
- [141] P. Venables and M. Christie. *Electrodermal Activity in Psychological Research*, chapter Chapter 1: Mechanisms, Instrumentation, Recording Techniques, and Quantification of responses, pages 1–124. ACADEMIC PRESS New York and London, 1973. 21
- [142] C. Vendel. The Atari Mindlink. <http://www.atarimuseum.com>, 2013. Last accessed August 2013. 2, 27, 31
- [143] H. Weidinger, G. Volbehr, W. Limpert, and H. Steusloff. Heart monitoring device with filter for suppressing the frequency of an ambient A.C. power source, May 1967. (patent) US3316897 A. 24
- [144] M. Wiethoff and E. Houwing. The value of psychophysiological measures in human-computer interaction. In *Proceedings of the Fourth International Conference on Human-Computer Interaction*, volume 18, pages 661–665, 1991. 21
- [145] Wild Divine. Iom active feedback. <http://www.wilddivine.com/accessories/iom-active-feedback-hardware-by-wild-divine/>, 2015. Last accessed February 2015. 25
- [146] G. Wilson, J. Lambert, and C. Russell. Performance enhancement with real-time physiologically controlled adaptive aiding. *Proceedings of the Human Factors and Ergonomics Society*, 1(13):61–64, 2000. 21
- [147] G. F. Wilson and F. T. Eggemeier. Mental workload measurement. *International Encyclopedia of Ergonomics and Human Factors*, 1, 2006. 9