

1966

# A statistical study of the static and fatigue properties of high strength prestressing strand

Raymond H. R. Tide  
*Lehigh University*

Follow this and additional works at: <https://preserve.lehigh.edu/etd>



Part of the [Civil Engineering Commons](#)

---

## Recommended Citation

Tide, Raymond H. R., "A statistical study of the static and fatigue properties of high strength prestressing strand" (1966). *Theses and Dissertations*. 3429.

<https://preserve.lehigh.edu/etd/3429>

This Thesis is brought to you for free and open access by Lehigh Preserve. It has been accepted for inclusion in Theses and Dissertations by an authorized administrator of Lehigh Preserve. For more information, please contact [preserve@lehigh.edu](mailto:preserve@lehigh.edu).

A STATISTICAL STUDY OF THE STATIC AND  
FATIGUE PROPERTIES OF HIGH STRENGTH  
PRESTRESSING STRAND

by

Raymond H. R. Tide

A THESIS

Presented to the Graduate Faculty

of Lehigh University

in Candidacy for the Degree of

Master of Science

Lehigh University

1966



CERTIFICATE OF APPROVAL

This thesis is accepted and approved in partial fulfillment of the requirements for the degree of Master of Science in Civil Engineering.

May 25, 1966  
(Date)



Professor D. A. VanHorn  
Professor in Charge

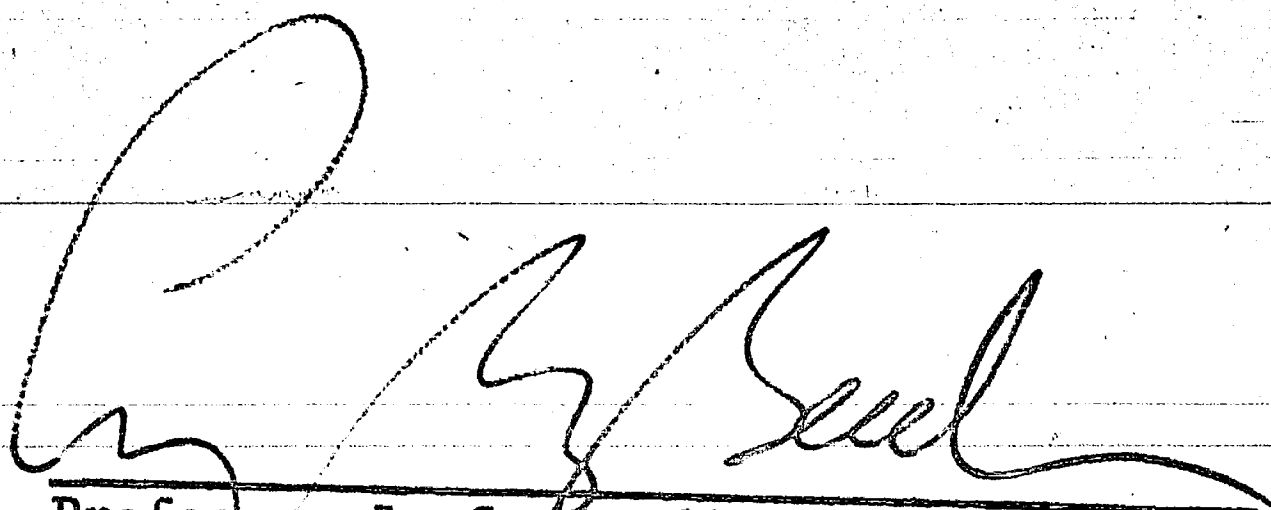

Professor L. S. Beedle, Acting Head  
Department of Civil Engineering

## A C K N O W L E D G E M E N T S

The author wishes to extend gratitude to Professor D. A. VanHorn for the guidance given during the writing of this thesis and for the direction provided, throughout the past year, to make it possible to complete the research.

The work described in this thesis was part of a research project conducted at Fritz Engineering Laboratory, Department of Civil Engineering, Lehigh University; sponsored by the Pennsylvania Department of Highways, the U.S. Department of Commerce - Bureau of Public Roads and the Reinforced Concrete Research Council.

Sincere appreciation is expressed for the capable help of the Fritz Engineering Laboratory staff and technicians and to S. H. Cowen for the assistance provided during the testing program. A special thanks to Mrs. V. A. Yarimci for the patience displayed while typing the manuscript.

## T A B L E   O F   C O N T E N T S

	<u>Page</u>
ABSTRACT	1
1. INTRODUCTION	3
1.1 Background	3
1.2 Previous Research	4
2. OBJECT AND SCOPE	15
2.1 Object	15
2.2 Scope	15
3. TEST SPECIMENS AND TESTING PROCEDURES	17
3.1 Static Tests	17
3.2 Fatigue Tests	20
4. TEST RESULTS	25
4.1 Static Tests	25
4.2 Fatigue Tests	26
5. DISCUSSION OF RESULTS	33
5.1 Static Results	33
5.2 Fatigue Results	35
5.2.1 Laboratory temperature	35
5.2.2 Low temperature	42

		<u>Page</u>
6.	SUMMARY AND CONCLUSIONS	44
7.	NOMENCLATURE	46
8.	TABLES	48
9.	FIGURES	59
10.	REFERENCES	83
11.	VITA	86

## LIST OF TABLES

<u>Table</u>		<u>Page</u>
1	List of Manufacturers and Plant Locations	49
2	Static Properties	50
3	Fatigue Test Results Minimum Stress = $0.60 f'_{s-ms}$	51
4	Fatigue Test Results Minimum Stress = $0.40 f'_{s-ms}$	52
5	Low Temperature Fatigue Test Results Stress Levels = $0.56 f'_{s-ms}$ - $0.80 f'_{s-ms}$	53
6	Statistical Results for Tests on Specimens A, B, and C Minimum Stress = $0.60 f'_{s-ms}$	54
7	Statistical Results for Tests on Specimens A, B, and C Minimum Stress = $0.40 f'_{s-ms}$	55
8	Statistical Comparison of Low Temperature Fatigue Test Data Stress Levels = $0.56 f'_{s-ms}$ - $0.80 f'_{s-ms}$	56
9	Grouping Data for Chi-Square Goodness-of-Fit Test	57
10	Grouping Data for Histogram Construction	58

## LIST OF FIGURES

<u>Figure</u>		<u>Page</u>
1	Cross-Sectional Arrangement of Seven-Wire Strands	60
2	Yield Strength for Prestressing Strand	61
3	Gripping of Test Specimens - Static Tests	62
4	Effectiveness of the Copper Grips	63
5	Extensometer - Static Tests	64
6	Static Test Setup with Extensometer	65
7	Typical Load-Strain Relationships for Prestressing Strand	66
8	Typical Stress-Strain Relationships for Prestressing Strand	67
9	Fatigue Test Specimens	68
10	Fatigue Test Setup	69
11	Specimens in Fatigue Test Setup	70
12	Mode of Strand Failure in Fatigue Tests	71
13	Maximum Stress Level vs. Fatigue Life, Specimen A	72
14	Maximum Stress Level vs. Fatigue Life, Specimen B	73
15	Maximum Stress Level vs. Fatigue Life, Specimen C	74
16	Comparison of Fatigue Life of Various Manufacturers	75
17	Comparison of Current Tests with Previous Research	76



<u>Figure</u>		<u>Page</u>
18	Effect of Lowering Temperature on Fatigue Life	77
19	Frequency Distribution of Grouped Constant Cycle Test Data	78
20	$\overline{\text{Log N}}$ vs. Load Range $R_s$	79
21	Standard Deviation $D$ vs. Load Range $R_s$	80
22	$\overline{\text{Log N}}$ vs. Stress Range $S_r$	81
23	$\overline{\text{Log N}}$ vs. $\text{Log } S_r$	82

## A B S T R A C T

In this study, an investigation has been made of the static and fatigue properties of 1/2-in. 270 ksi 7-wire prestressing strand. The specific properties investigated were the stress-strain relationship up to ultimate load, fatigue life under laboratory conditions, and the effect of low temperature on the fatigue life.

Samples of strand from five different manufacturers were used to establish the stress-strain relationships. The results indicate that all samples meet the minimum requirements specified in ASTM A416-64.

The S-N relationships were developed for strand from three of the manufacturers. In each case, two different minimum stress levels (40% and 60% of the minimum specified ultimate strength) were used.

A statistical analysis was made of the data, and equations are developed which express the fatigue life as a function of the minimum and maximum stress levels. The resulting S-N relationships are compared with those developed in earlier work for 7/16-in. 250 ksi 7-wire strand.

Finally, a pilot study was made of the effect of low temperature ( $0^{\circ}\text{F}$ ) on the fatigue life of the 1/2-in. 270 ksi strand. Samples from all five manufacturers were included in this part of the investigation. The specimens tested at low temperature were compared with a



group tested at normal laboratory temperature. One stress range  $(0.56 f'_{s-ms} - 0.80 f'_{s-ms})$  was used in all tests. The results indicate that this decrease in temperature apparently has little effect on the fatigue life of the strand.

## 1. INTRODUCTION

### 1.1 BACKGROUND

In 1949, a new era in construction was begun with the start of the erection of the Walnut Lane Bridge in Philadelphia. Completed in 1951, it was the first major prestressed concrete structure to be erected in the United States. Since that time, prestressed concrete has moved forward and taken its place as a major construction method. Its importance is emphasized by the results of a U.S. Bureau of Public Roads survey for the years 1957-60, which showed that 2052 prestressed concrete bridges has been authorized for construction.<sup>(8)</sup> In the years since then, prestressed concrete has gained significant importance in other construction areas such as buildings, towers and foundations.

The initial fabrication methods were adopted, in most cases, from European practice where prestressed concrete has been used extensively since the 1930's. In the years since 1949, however, construction procedures and methods have been geared to American manufacturing and labor conditions,<sup>(7)</sup> and as a result, most prestressed concrete flexural members in the United States are now manufactured by the pre-tensioning method utilizing 7-wire strands (Fig. 1), as compared to the individual wire elements more commonly used in Europe.

With each new improvement in material or technique, there follows the necessity for research to insure that the product meets

the standards established for safe, useable, and economical life span of the structure.

## 1.2 PREVIOUS RESEARCH

In the literature investigated, a common comment made by the authors is that research in prestressed concrete has lagged behind actual usage. In many cases, what was termed research was generally nothing more than user acceptance tests designed to indicate that a particular member was safe under the design loading which was simulated by the test conditions. In recent years, this trend has changed, and actual test programs have been organized to obtain the relevant properties, first, of the basic components, and then, of the manufactured members.

In Europe, as previously mentioned, individual wires of various diameters are commonly used as the primary prestressing elements, and as a result, their properties are tabulated in most manuals on the subject. Therefore, the use of the 7-wire strand in the United States has required a completely new series of tests to establish structural behavior characteristics. To further complicate matters, the manufacturers are producing new strands of higher strength and larger diameter at a faster rate than comprehensive tests can be planned and conducted. As a result, the latest static test results for 7-wire strand were reported by Lin,<sup>(8)</sup> Fisher and Viest<sup>(6)</sup> for 3/8-in. 250 ksi strand, Warner and Hulsbos<sup>(1)</sup> for 7/16-in. 250 ksi strand, Hanson<sup>(22)</sup> and Brecht<sup>(23)</sup> for 7/16-in. 270 ksi strand, and

Badaliane and VanHorn<sup>(24)</sup> for 1/2-in. 270 ksi strand. In the tests reported, no indication was explicitly given as to the mode of strand failure, that is, whether the test results represented a true ultimate failure within the gage length, or the more common failure in the gripping devices due to stress concentration. Since the results of the strand tests were of secondary emphasis in the investigations cited, the latter is probably the case. Fisher and Viest<sup>(6)</sup> indicated the difference between the stress-strain relationship for the 7-wire strand as compared with an individual wire element, while Warner and Hulsbos,<sup>(1)</sup> and Badaliane and VanHorn<sup>(24)</sup> indicated the difference between the stress-strain relationship of one of the individual wires of a 7-wire strand to that of the 7-wire strand itself.

The minimum requirements for the conventional 1/2-in. 7-wire prestressing strand are set forth in ASTM A416-64.<sup>(17)</sup> The principal requirements are: (1) a minimum of 3.5% elongation must be developed in a 24-in. gage length, and (2) 85% of the minimum specified ultimate load must be reached at 1% elongation. The 270 ksi strand is manufactured and tested within the provisions of this Standard, except that the specified minimum ultimate strength is 270 ksi, and the cross-sectional areas are slightly larger than the conventional nominal sizes.

The research conducted on the fatigue behavior of concrete beams was reviewed and summarized by Nordby<sup>(5)</sup> in 1958. It would be duplication to review most of the literature covered prior to this

date, but it is worthwhile to quote the summary of the results of previous research involving prestressed concrete structural elements:

#### Summary of Prestressed Concrete Results

Again, these statements should not be regarded as definite conclusions.

1. In none of the tests did concrete fail by fatigue. The current working stresses seem to give adequate protection in this regard.

2. Fatigue failure of stressing wires or strands was the cause of all failures reported. These failures seemed to be related to the extent and severity of the cracks.

3. Bond failures were rare and were found only under unusual circumstances, i.e., short beams, short shear span.

4. The ultimate strength of prestressed beams for static loads was unaffected by repetitive loading if they did not fail by fatigue.

5. Safety factors seemed to be approximately 2 against fatigue failure for most of the beams tested.

6. Prestressed beams seemed superior to conventional beams for resisting fatigue loading. In fact, in a recent paper, Ekberg and Walther analytically verified this by relating the modified Goodman diagram of both the concrete and prestressing steel to the theoretical stresses in both types of beam.

7. Further research is needed on bond failure and the action around cracks. Little progress can be made in this direction until these phenomena are understood for static loads. Efforts should be made toward establishing modified Goodman diagrams for both high strength concrete and steel as an aid to the analysis of prestressed beams subjected to fatigue loading.

#### Conclusions

Most of the research up to this time has been exploratory and investigators now know what to look for in their experiments. More research is needed in every phase of fatigue of concrete and future investigations should be well organized to isolate a particular variable. Research on



the fundamental properties of concrete fatigue to describe the mechanism of fatigue failures may be particularly fruitful. An understanding of this mechanism would make previous tests more valuable as well as improving those made in the future.

More research is needed to investigate the effect of moisture, aggregates, aggregate bond, curing, rest periods, microcracks in the paste, different environments of corrosive agents, specimen size, range of stress, combined loading, freezing and thawing, air entrainment, admixtures, temperature cycles, moisture cycles, accumulative fatigue damage, and previous stress histories on fatigue of both plain and reinforced concrete. In reinforced concrete efforts must be toward understanding the mechanism of bond and the mechanism of failure around tension cracks. A solution to this problem may be found in the newer x-ray methods pioneered by Evans. Other work must relate the results of fundamental properties to reinforced concrete structures.

The potential economic return for evaluation of these problems is almost fantastic. The saving in highway construction alone would be enormous if the life of concrete pavements could be prolonged 10 years by an understanding of fatigue. But greater funding for fundamental research will be necessary from both state and federal governments as well as industry to accomplish the task. Industry especially must modify its viewpoint to consider such investigations as long-time investment which will pay dividends in increased use of concrete over the years.

It is interesting to note that in all of the literature cited to that data, no mention was made on the fatigue properties of the individual strands. The fatigue studies on the individual wires conducted in Europe are not of much value, since the properties of individual straight wires are considerably different from those of 7-wire strand, as indicated by Preston<sup>(7)</sup> and Lin.<sup>(8)</sup>

The material covered in the above review, and the resulting conclusions were reflected in the trends in research which followed its publication.

In 1956, Nuwaysir<sup>(4)</sup> conducted a pilot study to determine, among other things, the best method for gripping prestressing strand. Using the results of seven tests incorporating 7/16-in. 7-wire strand, all having a minimum stress of 55.6% of static ultimate strength, but with different maximum stresses, an S-N curve was plotted. This pilot study was then used by Lane and Ekberg<sup>(3)</sup> to conduct a more extensive study of creep. In this study, thirteen specimens were tested, and two S-N curves were plotted for the 7/16-in. 7-wire strand used. Test results from seven specimens having a minimum stress of 54.5% were used for one curve, and the results from six specimens with a minimum stress of 65.2% were used for the other. The number of test specimens used to develop these three curves did not permit the drawing a significant conclusion, but this study represented the important first step upon which later research could be built. This study was not extensive enough to give Endurance Limits, but it did indicate that under reasonable working loads, nearly 1,000,000 stress cycles could be achieved prior to failure. Also, the first indication of the problem of scatter was mentioned, although not in detail due to the lack of information.

The next significant research was that of the AASHO Road Test as reported by Fisher and Viest.<sup>(6)</sup> In this test series, 18 speci-

mens of 3/8-in. 7-wire strand were tested, along with individual wires and normal reinforcing material. Although the number of samples was small, the test series was devised so as to bring out the maximum effect. This was achieved by using a 2 x 2 factorial arrangement involving two minimum stress levels and four maximum stress levels. From this data, two graphs were plotted using the mean of three values for each of the six points. Two straight lines were then drawn between each set of three mean values and the following mathematical model was obtained for the range of stresses covered by the tests:

$$\log N = 9.354 - 0.0423 S_r - 0.0102 S_{\min}$$

where

$N$  = number of cycles to failure

$S_r$  = range of stress,  $(S_{\max} - S_{\min})$

$S_{\max}$  = maximum stress

$S_{\min}$  = minimum stress

A statistical analysis was made to obtain the standard Error of Estimate and Coefficient of Correlation. The effect of  $S_{\min}$  was significant at the 10% level, but not at the 5% level, of the goodness-of-fit test. It was stated in the summary that the stress range was clearly the most important independent variable.

Closely following Fisher's work was a test program reported by Warner and Hulsbos<sup>(1)</sup> in which 122 specimens were tested. Of the total, 69 were tested in a constant-cycle fatigue test series, while the remainder were part of a cumulative damage fatigue test. The specimens incorporated 7/16-in. 250 ksi 7-wire strand, and were sub-



jected to either of two minimum stress levels, 40% or 60% of static ultimate strength obtained by testing, and several maximum stress ranges. The tests were grouped so as to have at least six repetitions of the same test in each of seven groups. To simulate infinite testing, four specimens were tested at stress levels low enough to insure no failure at less than three million cycles. One of the seven groups, having 20 specimens to enable a goodness-of-fit to be made, yielded a value well within the 5% significance level. The test results obtained indicated that only a statistical approach would provide answers with some degree of meaning.

Warner used the fatigue studies made by Freudenthal,<sup>(18)</sup> Muller-Stock,<sup>(20)</sup> Weibull,<sup>(21)</sup> and Grover, et al.<sup>(25)</sup> as the basis for his statistical approach. These studies indicate that the log-normal relationship is generally indicative of the statistic property of fatigue studies. Considering the small number of test specimens and the inherent scatter that was observed in fatigue studies, the log-normal distribution was considered suitable and adequate.

A second goodness-of-fit test was conducted on all of the constant cycle test results by reducing all of the data for the different stress ranges to a common parameter Z, given by the expression:

$$Z = \frac{\log N - \overline{\log N}}{D}$$

where

$$D = \left[ \frac{1}{n-1} \sum_{1}^n (\log N - \overline{\log N})^2 \right]^{1/2}$$

and

$\log N = \log$  of number of cycles  $N$  to failure

$\overline{\log N} =$  mean of  $\log N$

$D =$  standard deviation of  $\log N$

$n =$  number of specimens in group

The parameter  $Z$  reduces the various groups to one with a mean of zero and a standard deviation of unity. Using these results, a histogram was plotted and compared to a normal frequency distribution curve.

The normal S-N curves were also plotted and Endurance Limits were estimated to be 55% and 71% for the two minimum stress levels of 40% and 60%, respectively. The Endurance Limit was assumed to be a linear variation between these two levels, as expressed by the equation:

$$S_L = 0.8 S_{\min} + 23$$

The stress range  $R$  was then defined as follows:

$$R = S_{\max} - S_L$$

where

$S_L =$  Endurance Limit as a percent of static ultimate strength

$S_{\min} =$  minimum stress as a percent of static ultimate strength

$S_{\max} =$  maximum stress as a percent of static ultimate strength

The values of  $R$  were then plotted with  $\overline{\log N}$  and an equation was obtained by a least squares method as follows:

$$\overline{\log N} = \frac{1.4332}{R} + 5.5212 + 0.0486 R$$

Similarly, a least squares fit was also used to obtain an equation for the results of a plot of R versus D, and was given as:

$$D = 0.2196 - 0.0103 R.$$

In 1965, Hilmes and Ekberg<sup>(2)</sup> published a report in which 56 specimens of 7/16-in. 250 ksi, 7-wire strand were tested. All specimens had a minimum stress level of 50% of static ultimate strength obtained by testing. Various maximum stress levels were used.

In this study, a more refined statistical approach was taken in the preparation of the program. A probit test was based on 5 groups of specimens. The result indicated the requirement of at least 50 specimens in variable group sizes. The normal goodness-of-fit test was conducted to test the reliability of the results obtained.

An assumed Endurance Limit of 2,000,000 cycles was used as a basis to determine the percentage of tests that would survive at each level, the values of percent passing at each level and maximum stresses were transformed to develop a response curve according to the ASTM recommendations.<sup>(26)</sup> The results were plotted, and a least squares fit was used to obtain a sample standard deviation. Using the results to obtain values of percent survival, along with tabulated values from Ref. 26, S-N envelopes were plotted on a double logarithmic scale. Stress range  $S_r$  was used as the ordinate, instead of maximum stress, and was defined by:

$$S_r = S_{\max} - S_{\min}$$

$S_{\max}$  = maximum stress as a percent  
of static ultimate strength

$S_{\min}$  = minimum stress as a percent  
of static ultimate strength.

The results obtained indicated curves formed by two straight lines with breaks at 400,000 cycles. The equations of the curves obtained were as follows:

$$S_r = (1640 - 11.5 S_{\min}) N^{-0.320} \quad N \leq 400,000$$

$$S_r = (115.5 - 0.78 S_{\min}) N^{-0.1154} \quad N \geq 400,000$$

The equations obtained included data from Warner and Hulsbos<sup>(1)</sup> and therefore, have the limitations  $40\% \leq S_{\min} \leq 60\%$ . The test data agreed to within 5% of the values given by the equations.

In the literature reviewed, no mention was made of the effect of temperature on the static or fatigue properties of the 7-wire prestressing strand. As a result, only a general metallurgical fatigue concept will be reviewed. In general, the strength of steel increases as the temperature changes from a high of 500°F as indicated by AISC<sup>(16)</sup> and Timoshenko<sup>(15)</sup> down to a low of -250°F given by Parker.<sup>(12)</sup> Beyond this range of temperatures, ultimate strength is greatly reduced, as reflected by the change in failure mode. Parker states that below -250°F there is a transition from shear to cleavage failure.

Similarly, Forrest<sup>(14)</sup> states that the fatigue strength is increased as the temperature is reduced within approximately the same bounds. This concept is generally difficult to envision, since

the tendency is to associate brittle fracture with fatigue failure.

Finally, to emphasize that this is not the case, it is appropriate

to quote Jastrzebski: (13)

"There is no relation between increasing  
brittleness of steel at low temperatures  
and the fatigue strength."



## 2. OBJECT AND SCOPE

### 2.1 OBJECT

In general, the object of this research was to determine the static and fatigue properties of 1/2-in. 270 ksi, 7-wire prestressing strand. The specific areas investigated are as follows:

- 1) The stress-strain relationships of prestressing strand up to ultimate load and elongation.
- 2) The fatigue life of the prestressing strand under laboratory conditions.
- 3) The effect, on the fatigue life, of lowering the temperature of the test specimens to 0°F.
- 4) Comparison of the results obtained in 2) above with results obtained by Warner and Hulsbos,<sup>(1)</sup> and Hilmes and Ekberg.<sup>(2)</sup>

### 2.2 SCOPE

The test series consisted of 16 accepted static test results and 178 fatigue test specimens. The tests were conducted on samples of prestressing strand obtained from five manufacturers of prestressing strand in the United States. The manufacturers are listed alphabetically in Table 1, and the order has no correlation to the designations A, B, C, D, and E, used in the tables and figures. As a result, the manufacturer is not directly identified, as the intent of the investigation was to obtain results generally applicable to 1/2-in. 270 ksi,

7-wire prestressing strand produced in the United States within the ASTM designation A416-64.

The static tests were conducted on samples obtained from all five of the manufacturers listed. Of these five groups of samples, four groups represented samples taken from one roll of strand from each of the manufacturers. The fifth group of samples was taken from two separate rolls, manufactured two years apart.

Of the fatigue specimens tested, 140 comprised the main test series, that is, those tested at the laboratory temperature (70°F). The specimens for this series were divided into three approximately equal groups, representing the prestressing strand manufactured by firms A, B, and C. Each group of specimens was fabricated from an individual roll of prestressing strand.

The remaining 38 fatigue specimens were used to investigate the effect of low temperature on the fatigue properties of prestressing strand. This series was divided into five groups, which in turn were separated into two equal groups, one group being tested at laboratory temperature (70°F), and the other at 0°F. The five groups represented one roll from each of the five manufacturers.

### 3. TEST SPECIMENS AND TESTING PROCEDURES

#### 3.1 STATIC TESTS

The prestressing strand specimens used for the static tests were taken from different locations along the length of the samples obtained from the previously mentioned manufacturers. Each specimen was examined to insure that there were no obvious faults such as nicks or weldments within the gage length.

A requirement of the static test procedure was the development of the ultimate load, defined as the failure load occurring when the strand failed in the gage length. The most common method of testing prestressing strand was simply to use a commercial type of grip positioned tightly against a steel plate. In most cases, the teeth of the grip would cut into the strand, and the resulting stress concentrations around the indentations would cause premature failure. As a result, the ultimate load obtained in this manner would not reflect the full strength of the strand.

There have been various methods devised over the years to overcome this problem, and each one has its merits depending on the facilities and equipment available. The methods that have been used are briefly: (1) dulling the teeth of the strand grips, (2) coating the strand in the gripping region with molten tin, and (3) use of a molten zinc grout to secure the strand in a cast iron end-fitting.



The method finally adopted was a modification of the one used at Bethlehem Steel's Homer Research Center. In this method, the load is transferred by friction, from the strand through copper bars, to the testing machine head, over a relatively large area, and therefore, minimizing the effect of stress concentration. The friction force was achieved by a lateral force in the machine heads, which, prior to testing, squeezed the copper bars around the prestressing strand.

This feature of laterally squeezing a specimen in the grips is not available with the machines in Fritz Engineering Laboratory, but the same effect was achieved by placing a steel block across the exterior ends of the V grips (Fig. 3). The strandwise was then positioned tightly against the steel block. As the load was applied, the pressure exerted by the strandwise on the steel plate, and therefore to the machine grips, forced the machine grips to squeeze the copper bars as desired. In several tests, calibrated dynamometers were placed between the strandwise and the steel plates to determine the effectiveness of the copper bars (Fig. 4). The gripping ability of the copper bars was improved by winding fine (0.025-in.) steel wire around the strand before placing the copper bars.

Considerable difficulty is usually encountered in trying to obtain strain readings when testing prestressing strand. The normal commercial extensometers are difficult to use because the strand is very hard, thereby preventing efficient gripping. More important, however, is the problem of the strand twisting as the

load is increased. The strain indicators are disturbed as the strand twists, giving inaccurate strain readings.

This problem had been overcome in previous research at Fritz Engineering Laboratory by using an extensometer as shown in Figs. 5 and 6. The two brackets are placed 24 inches apart to provide the gage length required by ASTM Standard A416-64. To prevent abrasion from occurring when the steel clamps were tightened, plastic tubing was placed around the prestressing strand in the vicinity of the clamps. The strand elongation was measured by placing Ames dials (least count = 0.001 in.) on each end of the top bracket, and connecting them to the bottom bracket by piano wire. Readings of elongation were also obtained by affixing a horizontal cross-bar to two vertical straps attached to the top bracket. The horizontal cross-bar was silhouetted against a vertical strip-scale which was attached to the bottom bracket (Fig. 5).

Initial readings were taken on both the Ames dials and the strip-scale. Then, only Ames dial readings were taken at close intervals, until the stress-strain relationship was well out on the relatively level plateau. At this point, readings were again taken on the strip-scales. The Ames dials were then removed to prevent damage at strand failure. The strip-scale and cross-bar readings of 0.01-in. elongation over a 24-in. gage length were continued up to failure. This was possible since the actual readings were taken by using the telescope from a transit mounted at a safe distance from the test.

### 3.2 FATIGUE TESTS

For this test series, the prestressing strand samples were cut from the rolls in quantities as required for the fabrication of the specimens. Each portion of strand that would be located in or near the gage length was inspected for nicks or weldments.

An attempt was made to obtain a gage length of 24-in. for the fatigue specimens, but without success. Several arrangements were attempted, including those used in the static tests. However, the prestressing strand always failed in the grips at a number of cycles much less than was indicated in the previous investigations.

The method finally employed was identical to the one formerly used here at Fritz Engineering Laboratory (Fig. 9). The method consisted of cement-grout-encased prestressing strand, supported by steel clamps for attachment to the testing frame set-up (Figs. 10 and 11). Initially, the strand was pre-tensioned to 70% of the minimum specified ultimate load. Next, the steel clamps were aligned on the specimen using plastic tubing placed around the strand in the vicinity of the clamp end pieces. The spacing block was then placed in between each set of clamps, after which the strandvises were pressed against both ends. The prestressing load was then released and the excess strand was trimmed off. The space in between the steel clamps was then filled with a cement grout having a sand, cement, water ratio of 1.00:0.80:0.33. After the grout had cured, the transverse tension bolts were tightened to insure that a compressive force existed on the grout. Then, the specimen was ready for testing.

The prestressing strand was pre-tensioned to insure that a high percentage of the testing load was carried by the strand vises bearing on the end plates of the clamps. The remainder of the testing load was then transferred to the steel clamps by bond between the strand and the concrete. The initial twisting that occurs when a strand is subjected to loading was also eliminated. This secondary result would then improve the contact conditions between the strand and grout, resulting in a lower loss of load. The amount of prestress force remaining in the gage length was determined when the specimen was placed on the test set-up and loads applied. In most cases, the load required to remove the spacer block was between 50% and 60% of the minimum specified ultimate, and inspection of the specimen revealed that the length of bond lost after testing was generally less than 2 inches at the end of the gage length. The principal test set-up consisted of a cantilever arrangement (Fig. 10) activated by an Amsler pulsator. The one end of the specimen was connected to a fixed base while the other end was attached to the cantilever. The position of the specimen in the cantilever arrangement resulted in testing loads 1.33 times the pulsator dial readings.

When the initial set-up was made, several specimens had SR-4 gages mounted to permit dynamic strain readings to be taken. A comparison of strains with those of static tests indicated that the inertia effects were negligible.

To obtain an indication of the temperature of the prestressing strand under test condition, calibrated thermo-couples were attached to the strand using elastic insulation tape. The four thermo-couples were manufactured to give linear calibration curves, with sensitivity of 200 micro-inches-per-inch per degree Fahrenheit, in the range of temperatures of interest. As a result, it was possible to obtain accurate temperature readings under test conditions.

With the temperature control, it was possible to lower the temperature of the test conditions to 0°F as indicated in Figs. 10 and 11. This was achieved by bubbling nitrogen gas through liquid nitrogen. The valve on the nitrogen gas cylinder was regulated until the desired temperature was maintained.

The size of the thermo-couples permitted a reasonable contact between the edges of two exterior wire elements. However, it was impossible to get an indication of the temperature of the interior surfaces. The insulation tape also helped provide results with a reasonable degree of quality.

The actual procedure for testing a specimen can now be explained. After the grout had cured, and the transverse tension bolts tightened, the specimen was placed in the test set-up (Fig. 10). A gradually increasing static load was applied until the spacer block could be removed. The static load was then adjusted until only slightly larger than the desired minimum load. The dynamic load was then gradually applied until the maximum load value was obtained,



and then minor adjustments were made to both the minimum and maximum loads until the required load levels were obtained. The Amsler pulsator operates on a positive and negative hydraulic pressure system which means that the applied load varied sinusoidally between minimum and maximum load at 250 cycles per minute. This loading was continually applied until strand failure occurred, after which the specimen was broken apart, if necessary, to permit an inspection of the failure mode.

In order to complete the test program in a reasonable time, and at the same time, to allow coordination of the work with other research being conducted at Fritz Engineering Laboratory, it was necessary to use another test set-up. The second test set-up was a commercial alternating stress machine. In this set-up the specimen was attached to the base of the machine and to the moveable head. The moveable head was then activated by an Amsler pulsator. In the overall testing program, including both test set-ups, three different pulsators were used at different times.

The initial part of the test program was carried out in 1964 as a pilot study when 18 specimens were tested between the load ranges of  $0.56 f'_{s-ms}$  and  $0.80 f'_{s-ms}$ . The specimens were divided into three groups of six, each group representing one of the manufacturers A, B, or C. Each group of six had three specimens tested at laboratory temperature ( $70^{\circ}F$ ) and three at a low temperature ( $0^{\circ}F$ ).

The main part of the test program was continued in 1965, with the testing being conducted group-by-group. The specimens

from group C were tested first, followed by those from group B, and finishing with the specimens from group A. The specimens in each group were randomly arranged as far as the order of testing was concerned. The specimens in this group had a minimum of either 40% or 60% of the minimum specified ultimate strength.

The test program was completed with the testing of the last 20 specimens between load ranges of  $0.56 f'_{s-ms}$  and  $0.80 f'_{s-ms}$ . The series consisted of six specimens from group B, used as a comparison with the pilot study, with three specimens tested at laboratory temperature and three at low temperature ( $0^{\circ}F$ ). The next group represented manufacturer D with six specimens, again with three at each of the two test conditions of  $70^{\circ}F$  and  $0^{\circ}F$ . The final group represented manufacturer E with eight specimens divided into two sets of four each. The first set was tested at laboratory temperature conditions ( $70^{\circ}F$ ) and the second set at a low temperature of  $0^{\circ}F$ .

## 4. TEST RESULTS

### 4.1 STATIC TESTS

The final results obtained from the static tests, based on the actual cross-section area in each case, are given in Table 2, and Figs. 2 to 8. The results were obtained from 16 accepted tests as previously indicated. A test was considered acceptable if the failure occurred in the gage length (Fig. 6), as compared to failure in the gripping devices. As a result, there were several test specimens from each manufacturer's sample, which did not meet the above requirement. However, they were within the ASTM<sup>(17)</sup> requirement, with  $P_u$  greater than  $P_{sm}$ ,  $f_s$  greater than  $0.85 f'_{s-ms}$  at 1% elongation, and a total elongation greater than 3.5% at failure.

The difference in test results between the ASTM criteria for yield strength (1% elongation) and the often used value of 0.2% offset is illustrated in Fig. 2, and tabulated in Table 2.

To give an indication of how the load was distributed between the strandwise and the copper grips, the values obtained from the previously calibrated dynamometers, as shown in Fig. 3, were plotted in Fig. 4. These curves are only representative, since the curves changed considerably as the copper grips became worn.

The load-strain and stress-strain relationships are plotted in Figs. 7 and 8 respectively, along with the pertinent ASTM requirements. The actual values are tabulated in Table 2.



#### 4.2 FATIGUE TESTS

The data from the fatigue test series is tabulated in Tables 3, 4, and 5 followed by a compilation of various statistical properties in Tables 6 to 10.

The majority of the specimens subjected to a low stress range exhibited single wire element failure in the gage length (Fig. 12). The testing machines would automatically stop when a wire failed, leaving the remaining wires intact. In the case of the specimens tested at the high stress ranges, there generally was a chain reaction failure, even though the machine would stop. The brake on the machine was not capable of reducing the speed of the flywheel fast enough, and the dynamic load would then be near the ultimate load of the remaining wires. For most cases, this process would continue until all seven wires had failed.

Generally, it was possible to determine by inspection which wire element had failed first, as it was characterized by the fatigue failure mode (Fig. 12), as compared to a direct tension failure mode resulting from the chain reaction.

Whenever a specimen failed inside the gripping devices, a thorough check was made to insure that the failure was not caused by abrasion at the edge of the steel clamps. The specimens that failed as a result of this condition are marked with an asterisk in the tables.

Of the total of 178 fatigue specimens tested, the majority displayed a fatigue failure in a single exterior wire element, several had nearly simultaneous fatigue failure in two exterior wires, and in only one case did the central wire fail in fatigue.

Several of the tests having intermediate stress ranges were re-started after the first wire failed, with a proportioned reduction in load so as to obtain the same minimum stress and stress range as was used prior to failure. In several of these re-runs, the number of cycles required to cause the second wire to fail was nearly as large as the number which caused the initial failure. This phenomenon was not made part of the study, but mentioned only to further indicate the complexity of fatigue studies on prestressing strand.

Throughout the testing, it was noted that the temperature of the prestressing strand rose a considerable amount. As a result, the calibrated thermo-couples used to control the temperature of the low-temperature tests were also used to give an indication of the laboratory temperature test conditions. The temperature was found to rise  $25^{\circ}\text{F}$  and  $45^{\circ}\text{F}$  above laboratory conditions for specimens tested at stress ranges of  $0.60 f'_{s-ms}$  to  $0.85 f'_{s-ms}$ , and  $0.40 f'_{s-ms}$  to  $0.70 f'_{s-ms}$  respectively. These results reflect the rise in temperature for a thermo-couple attached to the outside edge of two exterior wire elements, and do not necessarily represent the rise in temperature of the interior surfaces.

The results of the fatigue tests at laboratory temperature for manufacturers A, B, and C are plotted in Figs. 13, 14 and 15,

respectively. The curves are drawn smoothly through the point, at each maximum stress level, which represents the mean of the logarithms of the individual number of cycles to failure. The effect of scatter, so commonly observed in fatigue studies, is quite evident. This is especially noticeable for each sample at the following stress levels:

Fig. 13 Specimen A  $0.60 f'_{s-ms}$  to  $0.80 f'_{s-ms}$

$0.60 f'_{s-ms}$  to  $0.76 f'_{s-ms}$

Fig. 14 Specimen B  $0.60 f'_{s-ms}$  to  $0.80 f'_{s-ms}$

$0.60 f'_{s-ms}$  to  $0.76 f'_{s-ms}$

Fig. 15 Specimen C  $0.60 f'_{s-ms}$  to  $0.80 f'_{s-ms}$

$0.40 f'_{s-ms}$  to  $0.60 f'_{s-ms}$

In Fig. 16 a comparison is made of the results from strand samples from the three manufacturers, by overlaying the resulting curves shown in Figs. 13, 14, and 15. Similarly, another comparison is made in Fig. 17 between the results of the current tests and the results reported in previous studies. In this figure the curves representing the present study are an average, at each minimum stress level, of the three curves from Figs. 13, 14, and 15. The effect of low temperature ( $0^{\circ}\text{F}$ ) on the prestressing strand is compared to that of laboratory test conditions ( $70^{\circ}\text{F}$ ) in Fig. 18. The curve representing  $0.56 f'_{s-ms}$  was interpolated from Fig. 17 and intersects the hori-

horizontal  $0.80 f'_{s-ms}$  maximum stress line at  $N = 110,000$  cycles. The vertical line then represents the intersection point of the  $0.56 f'_{s-ms}$  minimum stress curve and the  $0.80 f'_{s-ms}$  maximum stress level for each sample.

The data tabulated in Tables 6, 7, and 8 represent the statistical computations of Tables 3, 4, and 5, respectively. Each one of the three pairs of tables represents the results having a minimum stress of  $0.60 f'_{s-ms}$ ,  $0.40 f'_{s-ms}$ , or  $0.56 f'_{s-ms}$ .

Each of the statistical tables is divided into three parts; (1) identifying variables, (2) fatigue life statistical properties, and (3) logarithmic fatigue life properties.

The fatigue life properties are the mean fatigue life given by:

$$\bar{N} = \frac{\sum N}{n}$$

and the Standard Deviation from the mean as given by:

$$D_N = \left[ \frac{1}{n-1} \sum_1^n (N - \bar{N})^2 \right]^{\frac{1}{2}}$$

The ratio of  $D_N/\bar{N}$  then gives an indication of the extent of the scatter for each set of test specimens. Similarly, the mean of the logarithms for each set of test specimens was found by:

$$\overline{\text{Log } N} = \frac{\sum \text{Log } N}{n}$$

This quantity was then used to find the logarithmic Standard Deviation:

$$D = \left[ \frac{1}{n-1} \sum_{i=1}^n (\text{Log } N_i - \overline{\text{Log } N})^2 \right]^{\frac{1}{2}}$$

These statistical properties were then used to make graphical presentations. In Fig. 20, the load range,  $R_s$ , was plotted as the ordinate, with  $\overline{\text{Log } N}$  as the abscissa, for all laboratory temperature test specimens. A least squares solution was then obtained, yielding the second order equation:

$$\overline{\text{Log } N} = 6.356 - 0.1373 R_s + 0.00303 R_s^2$$

where:

$$R_s = S_{\text{max}} - S_L$$

$$S_L = 1.05 S_{\text{min}} + 8$$

The equation for the Endurance Limit,  $S_L$ , is based on an assumed straight line relationship within the following limitation:

$$40\% \leq S_{\text{min}} \leq 60\%$$

and thereby restricting  $R_s$ :

$$0 \leq R_s \leq 20\%$$

Similarly,  $R_s$  was correlated to the Standard Deviation,  $D$ , in Fig. 21, and a least squares fit was again applied to give a first order equation:

$$D = 0.153 - 0.0035 R_s$$



In Figs. 22 and 23 the stress range  $S_r$  was plotted with respect to  $\overline{\text{Log N}}$  to obtain two equations. The first (Fig. 22), is a log-normal function:

$$\overline{\text{Log N}} = 8.213 - 0.2077 S_r + 0.00316 S_r^2$$

The second (Fig. 23), is a log-log plot:

$$\overline{\text{Log N}} = 9.998 - 3.566 \text{Log } S_r$$

The equations are restricted to the range of stresses covered by the tests.

The statistical information required for a Chi-Square goodness-of-fit test is tabulated in Table 9. To enable all of the results from the laboratory test specimens to be used, it was necessary to use a change-of-variable parameter  $Z$  as the abscissa for a frequency distribution curve:

$$\text{where } Z = \frac{\log N - \overline{\log N}}{D}$$

The nine increments of  $Z$  were chosen so that the resulting area under the Theoretical Normal Curve (see Fig. 19, or Refs. 10 and 11)

$$Y = \frac{1}{\sqrt{2\pi}} e^{-Z^2/2}$$

was equal for each increment. The goodness-of-fit test is then expressed as:

$$\chi^2 = \frac{\sum(\text{OB} - \text{EX})^2}{\text{EX}}$$



With nine increments of  $Z$ , the number of degrees of freedom is eight, and the expression for  $\chi_{0.05}^2$  can be determined from any set of standard statistical tables as:

$$\chi_{0.05}^2 = 15.51$$

The values of  $\chi_{0.05}^2$  for the test series were:

$$A = 6.65$$

$$B = 21.86$$

$$C = 4.73$$

$$A+B+C = 16.44$$

Another comparison of the distribution of the fatigue tests with the Theoretical Normal Curve can be made by constructing a Histogram (Fig. 19). In this case, the increments of  $Z$  are chosen to be equal, and the number of observed failures in each increment is tabulated in Table 10. This number of observed failures then represents the vertical dimension of the shaded rectangles, to some convenient scale. The scale is chosen so that the sum of the area of the individual rectangles is approximately unity. The area obtained for the rectangles is then used as a scaling factor to proportionately change the ordinates of the Theoretical Normal Curve. The result of the above scaling is that the area of the shaded rectangles is equal to the area under the curve, between the limits of  $Z$  considered. The distribution of the test results is very similar to those obtained by Warner and Hulsbos,<sup>(1)</sup> in that the maximum number of failures occurred either to the right or left of the center line, with a marked absence in the range of  $Z$  between  $-0.25$  and  $-0.75$ .

## 5. DISCUSSION OF RESULTS

### 5.1 STATIC RESULTS

In making a comparison of the properties of the various strands, the difference in the cross-sectional area should be borne in mind, as well as the minimum requirements of ASTM Standard A416-64.<sup>(17)</sup> The Standard does not specifically cover the high strength strand, and therefore, the minimum specified ultimate load of 41.3 kips and nominal area of 0.153 sq. in. as quoted by the manufacturers will be used as a basis for the discussion. Based on these two quantities, a specified minimum ultimate stress of 270.0 ksi would be implied.

The range of the average ultimate loads was found to be from 42.6 kips to 44.3 kips, or 3.15% to 7.26% above the minimum specified ultimate load. In terms of stress, based on actual areas, the range was from 276.9 ksi to 284.6 ksi, or 2.56% to 5.40% above the specified minimum ultimate stress. The fact that all 16 of the accepted tests fell within such a narrow band, and above the minimum requirements, indicates the consistency of the prestressing strand.

Similarly, the requirement for a minimum elongation of 3.5%, based on a 24-in. gage length, was surpassed in each test. The minimum elongation for the test series was 21.4% above the required 3.5%.

The ASTM requirement that the yield strength (85% of the specified minimum ultimate load at 1%) was also achieved in every test. The lowest average for the strand from any manufacturer was 36.5 kips or 237.5 ksi, which were 3.99% and 3.49% greater than the minimum specified values of 35.1 kips and 229.5 ksi. The maximum value of 252.1 ksi is 9.85% above the minimum specified value. The 9.85%, when coupled with the 3.49%, again indicates the consistency of the strand tested. It is interesting to note that when considering the often-used definition of yield strength as the stress at 0.2% offset, the test results indicate a variation of from 1.5 ksi below to 3.9 ksi above the value obtained at 1% elongation. The difference between the two quantities for this specific type of prestressing strand is negligible, and for all practical purposes, these two definitions produce equivalent results.

The final property tabulated in Table 2 is the modulus of elasticity for the strand. The values listed are again the average of several tests for each manufacturer. The actual range of values obtained was from 27,700 ksi to 30,600 ksi, with the former belonging to a group with an average of 28,500 ksi, while the latter belonged to the group with an average of 29,800 ksi. The values listed are higher than those generally quoted. The difference might be attributed to the pre-loading required to seat the copper grips, as described in Chapter 3. This pre-loading would undoubtedly reduce the slack between the individual wires. The method of cutting

the short specimen lengths (60 inches) from the reels may have had an effect also, as it was found that unless care was taken to fuse the individual wires together, the exterior wires had a tendency to become loose in the end regions. A review of the data from previous research at Fritz Engineering Laboratory, obtained by several other methods, yielded results similar to the tabulated values.

## 5.2 FATIGUE RESULTS

### 5.2.1 Laboratory Temperature

In the preceding section describing static tests, it was possible to use an arithmetic mean to adequately express the static properties of prestressing strand. However, an examination of Tables 3 and 4 indicates that this approach could be misleading for fatigue studies. The major difficulty encountered in a fatigue study is due to the inherent scatter of test results. Studies have shown that the fatigue life of a specimen depends upon the individual fiber stresses and stress concentration. However, due to the nature of testing procedures, most tests are performed using average stresses, based on a load as measured by machine indicator, and the average cross-sectional area of the specimen. In studies of solid, homogeneous material, results have been obtained where the divergence from the mean value is greater than the mean itself. With this in mind, it is understandable that so much scatter was obtained, particularly when considering the nature of 7-wire prestressing strand.

The fatigue failure shown in Fig. 12, represents the failure mode of the majority of the test specimens. The fatigue failure begins on the interior face of an exterior wire element and proceeds approximately mid-way through the wire. At this point the stress on the area remaining intact is so great that final failure suddenly occurs by a direct tensile mode. This failure pattern indicates that the friction between the face of the wire that failed, the center wire, and the adjacent exterior wire may produce an undesirable stress concentration which initiates the fatigue failure.

The stress ranges at which excessive scatter occurred were previously indicated and can be seen in Figs. 13, 14, and 15, or from the ratio  $D_N/\bar{N}$  in Tables 7 and 8. There are two factors which appear to influence the extent of the scatter. The first, is the magnitude of the maximum stress. The greatest amount of scatter occurred when the maximum stress was either  $0.76 f'_{s-ms}$  or  $0.80 f'_{s-ms}$ , which is generally in the vicinity of the beginning of the inelastic region of the stress-strain relationship. The second factor is the magnitude of the stress range  $S_r$ . This factor overlaps with the first in most cases, but it also appears to account for the scatter which occurs when both the maximum and minimum stress are relatively low. These two factors are a result of the spinning process by which prestressing strand is manufactured. As a result of this process, the individual wire elements of the strand are under variable loads. Therefore, when the average stress on the strand is near the inelastic region of the stress-strain relationship, some wire elements



will still be in the initial elastic region, while others will be in the inelastic region. Studies have shown that the fatigue life of a specimen is increased if it has been strained into the inelastic region. This phenomenon occurs because, under these conditions, the load is distributed uniformly across the cross-section. In the cutting process, the center wire was observed to pull in when a poor cut was made. This indicates that the center wire is under tension and as a result, would be the first wire stressed into the inelastic region. Since this wire is relatively straight compared to the exterior wires, its stress would be more uniformly distributed than the others. These two facts may account for the occurrence of only one center wire fatigue failure out of 178 test specimens.

The difference in load distribution also accounts for the scatter with a high stress range, at stresses well below the inelastic region. Some wires will be stressed considerably higher than others, and therefore, the fatigue life will be lower.

The cause of the scatter was investigated by constructing various relationships between the load range, stress range, and number of cycles to failure, as illustrated in Figs. 19 through 23. As was previously mentioned, the Histogram (Fig. 19) displayed a frequency distribution very similar to that obtained by Warner and Hulsbos.<sup>(1)</sup> The majority of the values of  $Z$  which fell into the ranges that produced the two highest ordinates of the Histogram were from stress ranges that had considerable scatter, whereas the other stress ranges



are proportioned throughout the range of  $Z$  considered. No explanation can be given as to why the maximum number of points fell into the same region in both the Warner and Hulsbos report, and the current study.

The equations for  $\overline{\text{Log } N}$ , derived from Fig. 20 and Fig. 22, indicate the difference obtained when the load range,  $R_s$ , is used as compared to the stress range,  $S_r$ . The advantage of the latter parameter is that the Endurance Limit for the material need not be determined. In this study it was possible to make a reasonable estimate for the Endurance Limit, but since the number of specimens tested in the low stress range level was small, the accuracy was limited. On the other hand, the stress range is clearly defined within the range of stresses considered. A second order equation was found to be the most reasonable mathematical model in both cases. In Fig. 23,  $\overline{\text{Log } N}$  is plotted with  $\text{Log } S_r$  to obtain another equation which was found best suited to a linear form. To emphasize the comparison, the values of  $N$  are tabulated below for each of the three equations for two different testing conditions.

	$0.60 f'_{s-ms}$	$0.40 f'_{s-ms}$
	$0.80 f'_{s-ms}$	$0.52 f'_{s-ms}$
Fig. 20	233,000	1,240,000
Fig. 22	210,000	1,495,000
Fig. 23	228,000	1,410,000

The above numbers indicate that for this study, the difference in the

results obtained from the various equations is not too significant when compared to the scatter obtained in the actual testing.

In previous studies, a correlation was indicated between the Standard Deviation,  $D$  and the range of stresses. An examination of Fig. 21, indicates that there is some validity in the relationship in that as the load range,  $R_s$ , is reduced, the deviation increases. The relationship would be more pronounced if points corresponding to the test results at the lowest load ranges were neglected, since these points represent only two or three specimens. On the other hand, the points at the higher stress ranges generally represent 6 or more test specimens.

The results of the goodness-of-fit test indicate that for test series for manufacturers A and C the  $\chi^2$  values of 6.65 and 4.73 are well within the  $\chi_{0.05}^2$  value of 15.51, whereas the value of 21.86 for manufacturer B indicates that generally there was too much scatter. Considering the results of the three groups as one, the  $\chi^2$  value of 16.44 is just beyond the theoretical value of 15.51. The value of  $\chi^2$  gives an indication of the reliability of the testing procedure and the control of the inherent variables during testing. The above values, therefore, indicate that for specimens made from the sample from manufacturer B some variable may not have been accounted for.

In Fig. 16 a comparison is made between the individual S-N curves of Figs. 13, 14, and 15. Considering the previous discussion on scatter, the relative difference between the three curves

can be considered negligible and as a result, a curve representing the average result will be used in the subsequent discussion.

In the comparison between the current research with that of previous research (Fig. 17) it can be seen that the difference is not too significant. It should be remembered that the previous Lehigh<sup>(1)</sup> test series and the Iowa State<sup>(2)</sup> test series were based on 7/16-in. 250 ksi 7-wire strand, whereas the present study is based on 1/2-in. 270 ksi 7-wire strand. The Iowa State study had only one minimum stress level ( $0.50 f'_s$ ) while the previous Lehigh study included two minimum stress levels,  $0.40 f'_s$  and  $0.60 f'_s$ . The present study, however, used two minimum stress levels of  $0.40 f'_{s-ms}$  and  $0.60 f'_{s-ms}$  to enable a comparison to be made between the strand obtained from the various manufacturers. This difference is not significant as the maximum difference between  $f'_s$  and  $f'_{s-ms}$  was previously given as 5.40%.

The curves obtained from the present study do not explicitly indicate an Endurance Limit, but when compared to the previous Lehigh study it is obvious that at the  $0.60 f'_{s-ms}$  minimum level, it would require only a small reduction of maximum load to achieve much more than 2,000,000 cycles of loading. At the  $0.40 f'_{s-ms}$  minimum level however, it appears that a greater decrease in maximum load should have been employed to reach cycles well beyond the 2,000,000 level. Values of  $0.71 f'_{s-ms}$  and  $0.50 f'_{s-ms}$  were taken as the Endurance Limit for the minimum stress levels of  $0.60 f'_{s-ms}$  and  $0.40 f'_{s-ms}$  respectively,

or roughly 10% of the minimum specified ultimate stress above the minimum stress level.

It is interesting to note that for a 10% increase in stress in the elastic region in the prestressing strand, there would be a corresponding increase of 2.8 ksi in the adjacent concrete. This would indicate that for prestressed concrete members governed by the present design codes, the stress range to which a member is subjected would rarely exceed  $0.10 f'_{s-ms}$ . Therefore, the member would have a fatigue life in the vicinity of approximately 2,000,000 cycles. The literature reviewed indicated that whenever a prestressed member failed in fatigue, the failure was generally attributed to fatigue in the prestressing strand, indicating a discrepancy between the above statement and the actual condition. This discrepancy has been explained by other investigators who have found that even though the prestressing element has a reasonable fatigue life when tested alone, the fatigue life is lessened when the element is tested in conjunction with concrete. Initial studies have indicated that when a crack pattern develops in a concrete member and extends to the reinforcing element, the resulting stress conditions tend to reduce the fatigue life of the element considerably. It was found, and explained earlier, that whenever stress concentrations were introduced, as a slight mis-alignment of specimens, the fatigue life of a prestressing strand was considerably reduced, thereby substantiating the previous reasoning.

### 5.2.2 Low Temperature

The results from the low temperature test series are presented in Table 8, and shown graphically in Fig. 18. The amount of scatter was considerably less than in the main test series, as reflected in the ratio  $D_N/\bar{N}$  and  $D$  in Table 8, and Fig. 18.

In general, the results indicate that the fatigue life increases as the temperature of the test specimen is lowered. An examination of the Low-Fatigue-Life data will show that for the samples obtained from manufacturers B, D, and E the fatigue life increased 32,600, 30,600, and 16,300 cycles respectively, for the low temperature condition, whereas, for A, and B, there was only a decrease of 1,300 and 9,800 cycles, respectively. This indicates that the result is somewhat in agreement with the metallurgical concept which indicates an increase in fatigue life with lowered temperature, when the temperatures considered fall between 500°F and -250°F. The range of temperatures considered was not great enough to produce a conclusive result, but did indicate that the results of the tests are in agreement with this concept.

The curve representing  $0.56 f'_{s-ms}$  in Fig. 18 was interpreted from Fig. 17, to enable a comparison to be made with the main test series. The interpretation was made assuming a linear relationship between  $0.40 f'_{s-ms}$  and  $0.60 f'_{s-ms}$ . Only the specimens from manufacturer A fell to the right of the vertical line representing a minimum stress of  $0.56 f'_{s-ms}$  and a maximum stress of  $0.80 f'_{s-ms}$ .



The other four sets of specimens exhibited mean values very close to the line, as can be seen from Table 8 and Fig. 18. This would indicate the validity of the linear assumption within the range of stresses considered.



## 6. S U M M A R Y   A N D   C O N C L U S I O N S

The objective of this research was to determine the static and fatigue properties of 1/2-in. 270 ksi 7-wire prestressing strand and compare the results obtained with those from tests of the conventional 250 ksi 7-wire strand. The effect of lowering the temperature of the test specimens was also investigated to determine the possibility of a change in the fatigue life at low temperatures.

A total of 16 accepted static tests and 178 fatigue tests were conducted on samples obtained from five U.S. manufacturers of the high strength prestressing strand.

The results of the static tests indicate that the static properties of all five samples are fairly consistent and within the provisions of ASTM Standard A416-64. The variation observed in the results can be considered as negligible in comparison to the usual variation encountered in the surrounding concrete.

The fatigue life of the high strength 1/2-in. 270 ksi 7-wire prestressing strand compares favorably with that of the conventional 250 ksi strand. The small difference in the results may be due to the fact that the previous studies were conducted on 7/16-in. 250 ksi 7-wire as compared to the 1/2-in. strand used in this study. The use of the specified minimum ultimate load as a base upon which to perform the tests, as compared to the actual ultimate load, would not change the results appreciably. In an attempt

to eliminate the effect of scatter, three equations were developed for the fatigue life of a specimen, using three slightly different parameters.

The fatigue life of a specimen was found to increase slightly as the temperature of the test specimen was reduced. This was as expected from a metallurgical point of view. However, the increase was not significant, as the change in temperature was not great enough to affect the properties.

It was observed that at stresses in the working load range, the fatigue life of a specimen was in the vicinity of approximately 2,000,000 cycles of loading. Since studies of prestressed concrete flexural members have shown that the prestressing strand fails in fatigue at a significantly lower number of cycles, it is suggested that more tests be conducted at the low stress range level, using a test set-up that could simulate cracks in concrete crossing the strand. At the same time, it would be useful to conduct a dynamic strain study to determine the actual distribution of load among the seven wire elements.

## 7. N O M E N C L A T U R E

A	cross-sectional area of prestressing strand
D	standard deviation of Log N
$D_N$	standard deviation of N
$E_{str}$	modulus of elasticity for prestressing strand
EX	expected number of failures in specified range of Z
$\epsilon$	elongation of prestressing strand
$f'_s$	ultimate stress in steel
$f'_{s-ms}$	minimum specified ultimate stress in steel
$f_{s-0.2}$	stress in steel at 0.2% offset
$f_{s-0.1}$	stress in steel at 1.0% elongation
Log N	Logarithm of N, base 10
$\overline{\text{Log N}}$	mean of Log N
Log $S_r$	logarithm of $S_r$ , base 10
N	number of cycles of load to failure
$\overline{N}$	mean of fatigue life N
n	number of test specimens in the group
OB	observed number of failures in specified range of Z
$P_{sm}$	minimum specified ultimate load
$P_{s-0.2}$	load at 0.2% offset
$P_{s-1.0}$	load at 1.0% elongation
$P_u$	ultimate load
$R_s$	load range $S_{msx} - S_L$ as a percent of $P_{sm}$

$S_{max}$  maximum dynamic stress as a percent of  $f'_{s-ms}$   
 $S_{min}$  minimum dynamic stress as a percent of  $f'_{s-ms}$   
 $S_L$  Endurance Limit  
 $S_r$  stress range  $S_{max} - S_{min}$  as a percent of  $f'_{s-ms}$   
Y vertical coordinate  
Z change of variable parameter  
 $Z_{inc.}$  increment of Z

8. T A B L E S



**Table 1      List of Manufacturers  
and Plant Locations**

**Armco Steel Corporation  
(Union Wire & Rope)**

**Kansas City  
Missouri**

**Bethlehem Steel Corporation**

**Sparrows Point  
Maryland**

**Colorado Fuel & Iron Corporation  
(John A. Roebling's Sons Division)**

**Trenton  
New Jersey**

**Florida Wire & Cable Company**

**Jacksonville  
Florida**

**United States Steel Corporation  
(American Steel & Wire Division)**

**Waukegan  
Illinois**



Table 2 Static Properties

Properties	Units	Manufacturer				
		A	B	C	D	E
A	in. <sup>2</sup>	0.154	0.158	0.155	0.154	0.153
P <sub>u</sub>	kips	42.6	44.3	43.3	43.8	42.7
f' <sub>s</sub>	ksi	276.9	281.5	279.8	284.6	279.5
ε	%	4.86	5.68	5.19	4.83	4.25
P <sub>s-0.2</sub>	kips	36.3	39.0	39.1	39.4	38.3
f <sub>s-0.2</sub>	ksi	236.0	247.6	252.9	256.0	250.7
P <sub>s-1.0</sub>	kips	36.5	38.5	38.7	38.8	37.9
f <sub>s-1.0</sub>	ksi	237.5	244.4	250.5	252.1	248.0
E <sub>str</sub>	ksi	29,500	28,500	29,500	29,800	29,300

Table 3 Fatigue Test Results

Minimum Stress =  $0.60 f'_{s-ms}$

Maximum Stress	Number of Cycles - N		
	Manufacturer		
	A	B	C
$0.85 f'_{s-ms}$	78,500	92,300	208,600
	81,700	62,500	94,400
	88,600	98,300	97,000
	87,800	55,300	111,200
	87,200	90,700	82,300
	96,300	97,600	144,300
$0.80 f'_{s-ms}$	190,700	174,000	199,500
	148,400	77,500	116,900
	267,900	127,800	197,900
	104,600	254,400	439,300
	151,000	215,700	152,700
	178,500	113,500	356,400
$0.76 f'_{s-ms}$	439,100	183,900	332,100
	842,900	517,200	333,600
	215,200	370,000	273,400
	326,400	353,700	28,200*
	232,100	487,400	307,600
	254,200	512,500	489,300
	334,800	653,800	
	449,000		
$0.72 f'_{s-ms}$	1,405,500	1,115,900	1,728,600
	1,635,000	722,000	2,031,900
	1,091,000	1,224,900	2,083,800

\* Failure at grip due to abrasion.

Table 4 Fatigue Test Results  
 Minimum Stress =  $0.40 f'_{s-ms}$

Maximum Stress	Number of Cycles - N		
	Manufacturer		
	A	B	C
$0.70 f'_{s-ms}$	71,700	74,300	97,500
	67,800	75,200	68,800
	77,200	60,000	55,800
	69,400	74,200	58,500
	50,000	69,800	78,400
	58,500	74,800	84,400
$0.65 f'_{s-ms}$	99,200	131,100	123,500
	75,800	96,700	80,600
	80,900	95,900	123,300
	112,600	91,800	96,400
	101,000	120,500	166,700
	107,100	120,100	204,000
$0.60 f'_{s-ms}$	156,400	338,000	630,000
	281,100	303,000	223,700
	218,000	326,800	484,900
	252,400	184,400	137,700
	261,200	235,500	301,900
	176,300		272,200
$0.56 f'_{s-ms}$			169,200
	721,700	763,000	615,800*
	723,000	428,000	1,189,900
	1,154,000	600,400	976,600
$0.52 f'_{s-ms}$			919,000
			745,100
	2,241,000	928,000	1,747,000
	2,282,000	2,185,000	1,427,000
	772,500	1,281,300	1,901,000

\* Failure at grip due to abrasion

Table 5 Low Temperature Fatigue Test Results

Stress Levels =  $0.56 f'_{s-ms}$  -  $0.80 f'_{s-ms}$

Manufacturer	0°F	70°F
A	160,300	158,700
	207,400	242,500
	147,600	130,500
B	92,500	54,100
	122,400	79,900
	86,500	53,400
	112,100	73,300
	104,700	107,900
	148,500	111,600
C	139,800	112,500
	99,600	138,100
	104,200	119,900
D	90,800	59,800
	127,800	87,200
	103,300	82,800
E	124,100	56,800*
	121,100	88,900
	119,800	114,000
	104,800	101,500

\* Failure at grip due to abrasion

Table 6 Statistical Results for Tests on Specimens A, B, and C  
 Minimum Stress =  $0.60 f'_{s-ms}$

Manf. No. of Samples	Max. Stress % of $f'_{s-ms}$	Fatigue Life			Log Fatigue Life			
		$\bar{N}$	$D_N$	$D_N/\bar{N}$	$\overline{\text{Log } N}$	D	$\text{Log}^{-1}(\overline{\text{Log } N})$	
A	6	85	86,700	5,600	0.0648	4.9370	0.0308	86,500
A	6	80	173,500	50,200	0.2893	5.2216	0.1357	166,600
A	7	76	377,800	202,700	0.5364	5.5301	0.2046	338,900
A	3	72	1,377,200	223,000	0.1619	6.1331	0.0888	1,358,500
B	6	85	82,800	17,200	0.2081	4.9072	0.1090	80,800
B	6	80	160,500	60,800	0.3792	5.1718	0.1915	148,500
B	8	76	440,900	130,900	0.2970	5.6200	0.1668	416,900
B	3	72	1,020,900	216,000	0.2116	5.9981	0.1225	995,600
C	6	85	123,000	43,000	0.3493	5.0670	0.1487	116,700
C	6	80	243,800	115,000	0.4718	5.3405	0.2184	219,000
C	5	76	347,200	74,300	0.2141	5.5318	0.0949	340,200
C	3	72	1,948,100	156,600	0.0804	6.2881	0.0440	1,941,500

Table 7 Statistical Results for Tests on Specimens A, B, and C  
 Minimum Stress =  $0.40 f'_{s-ms}$

Manf. No. of Samples	Max. Stress. % of $f'_{s-ms}$	Fatigue Life			Log Fatigue Life			
		$\bar{N}$	$D_N$	$D_N/\bar{N}$	$\overline{\text{Log } N}$	D	$\text{Log}^{-1}(\overline{\text{Log } N})$	
A	6	70	65,800	9,000	0.1367	4.8136	0.0687	65,100
A	6	65	96,100	13,400	0.1390	4.9783	0.0639	95,100
A	6	60	224,200	45,300	0.2022	5.3411	0.1017	219,400
A	3	56	866,200	203,500	0.2349	5.9266	0.1175	844,400
A	3	52	1,765,200	702,100	0.3978	6.1989	0.2694	1,580,800
B	6	70	71,400	5,400	0.0756	4.8523	0.0382	71,200
B	6	65	109,400	15,100	0.1378	5.0347	0.0654	108,300
B	5	60	277,500	58,600	0.2112	5.4325	0.1116	270,700
B	3	56	597,100	136,800	0.2291	5.7641	0.1262	580,900
B	3	52	1,464,800	529,300	0.3614	6.1382	0.1878	1,374,700
C	6	70	73,900	14,600	0.1975	4.8602	0.0940	72,500
C	6	65	132,400	41,700	0.3151	5.1008	0.1483	126,100
C	7	60	317,100	165,200	0.5211	5.4452	0.2361	278,800
C	4	56	957,700	158,900	0.1659	5.9752	0.0837	944,500
C	3	52	1,691,700	197,400	0.1167	6.2252	0.0640	1,679,700



Table 8 Statistical Comparison of Low Temperature Fatigue Test Data  
 Stress Levels =  $0.56 f'_{s-ms}$  -  $0.80 f'_{s-ms}$

Manf. Temp. (°F)	No. of Samples	Fatigue Life			Log Fatigue Life		
		$\bar{N}$	$D_N$	$D_N/\bar{N}$	$\overline{\text{Log } N}$	D	$\text{Log}^{-1}(\overline{\text{Log } N})$
A 0	3	171,800	25,700	0.1498	5.2303	0.0771	169,900
A 70	3	177,200	47,600	0.2684	5.2336	0.1376	171,200
B 0	6	111,100	20,500	0.1844	5.0387	0.0851	109,300
B 70	6	80,000	23,100	0.2886	4.8848	0.1392	76,700
C 0	3	114,500	18,000	0.1569	5.0539	0.0800	113,200
C 70	3	123,500	10,800	0.0871	5.0901	0.0456	123,000
D 0	3	107,300	15,400	0.1432	5.0262	0.0750	106,200
D 70	3	76,600	12,000	0.1569	4.8784	0.0888	75,600
E 0	4	117,500	7,500	0.0636	5.0689	0.0330	117,200
E 70	3	101,500	10,200	0.1010	5.0041	0.0540	100,900

Table 9 Grouping Data for Chi-Square Goodness-of-Fit Test

Z	Manufacturer							
	A		B		C		A+B+C	
	OB	EX	OB	EX	OB	EX	OB	EX
$-\infty \leq Z < -1.220$	5	5.44	5	5.66	4	5.44	14	16.67
$-1.220 \leq Z < -0.766$	8	5.44	8	5.66	9	5.44	25	16.67
$-0.766 \leq Z < -0.430$	4	5.44	3	5.66	4	5.44	11	16.67
$-0.930 \leq Z < -0.140$	3	5.44	6	5.66	6	5.44	15	16.67
$-0.140 \leq Z < 0.140$	4	5.44	1	5.66	6	5.44	11	16.67
$0.140 \leq Z < 0.430$	8	5.44	5	5.66	4	5.44	17	16.67
$0.430 \leq Z < 0.766$	8	5.44	14	5.66	4	5.44	26	16.67
$0.766 \leq Z < 1.220$	6	5.44	8	5.66	6	5.44	20	16.67
$1.220 \leq Z < \infty$	3	5.44	2	5.66	6	5.44	11	16.67
$\Sigma$	49	49	52	52	49	49	150	150

Table 10 Grouping Data for Histogram Construction

Z	Manufacturer				Y	Z <sub>inc.</sub>	A
	A	B	C	A+B+C			
	OB	OB	OB	OB			
-2.25 ≤ Z < -1.75	0	2	0	2	0.025	0.05	0.0125
-1.75 ≤ Z < -1.25	5	3	2	10	0.125	0.05	0.0625
-1.25 ≤ Z < -0.75	8	9	11	28	0.350	0.05	0.1750
-0.75 ≤ Z < -0.25	6	5	5	16	0.200	0.05	0.1000
-0.25 ≤ Z < 0.25	8	6	13	27	0.3375	0.05	0.16875
0.25 ≤ Z < 0.75	13	16	6	35	0.4375	0.05	0.21875
0.75 ≤ Z < 1.25	6	10	6	22	0.275	0.05	0.1375
1.25 ≤ Z < 1.75	2	1	6	9	0.0875	0.05	0.04375
1.75 ≤ Z < 2.25	1	0	0	1	0.0125	0.05	0.00625
$\Sigma$	49	52	49	150	-	-	0.9250

9. FIGURES

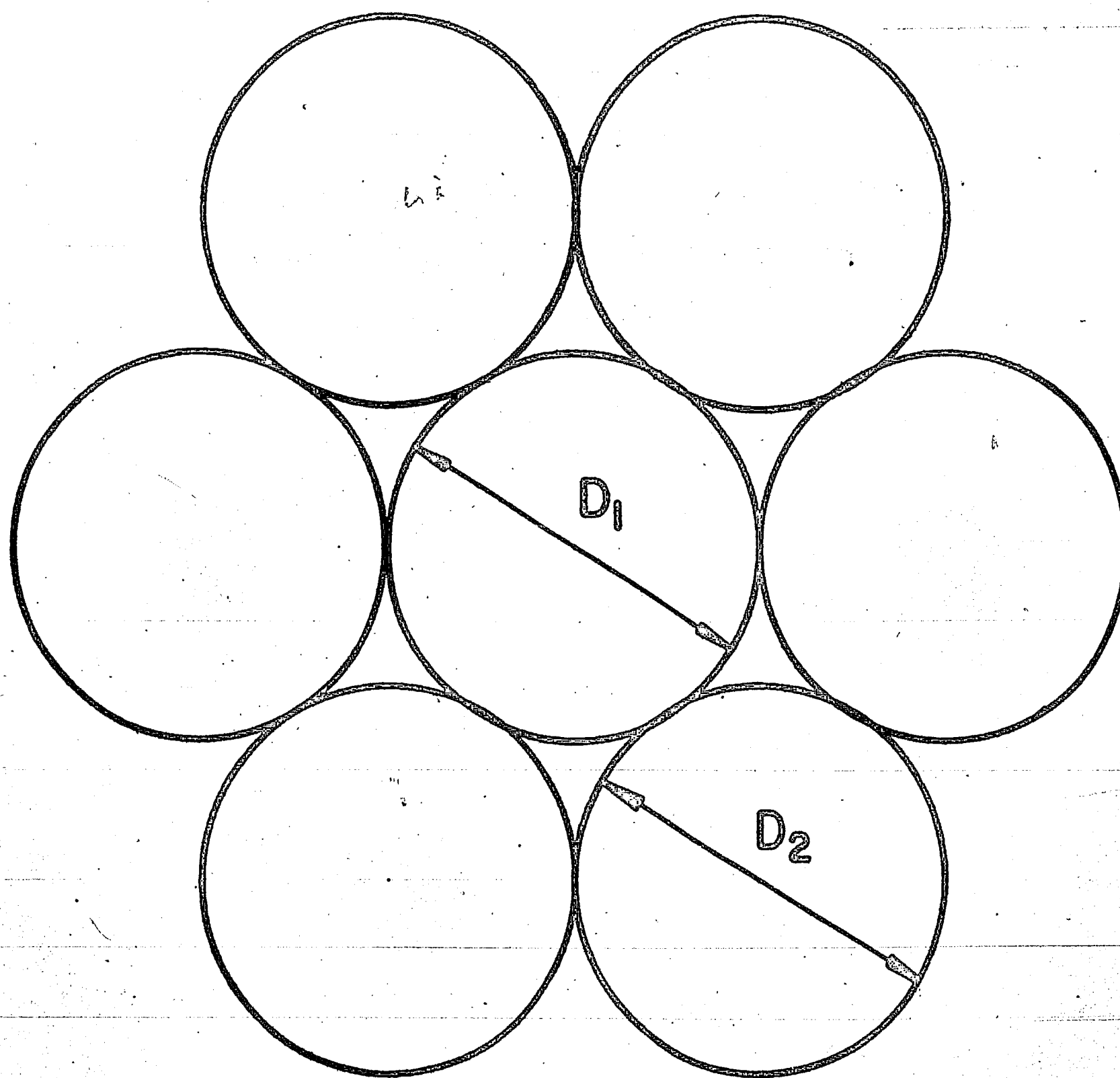

$$D_1 > D_2$$

Fig. 1 Cross-Sectional Arrangement of Seven-Wire Strands



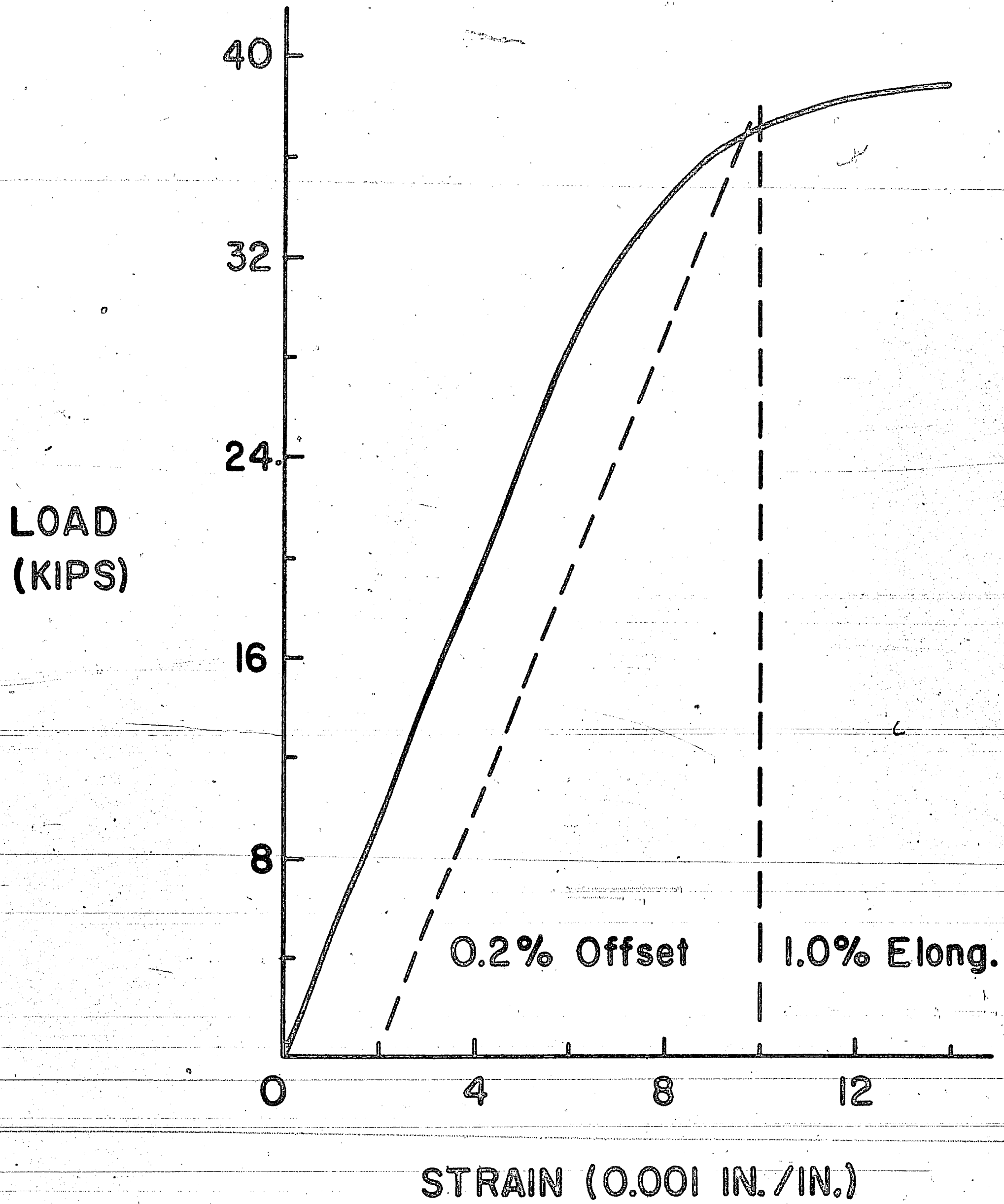
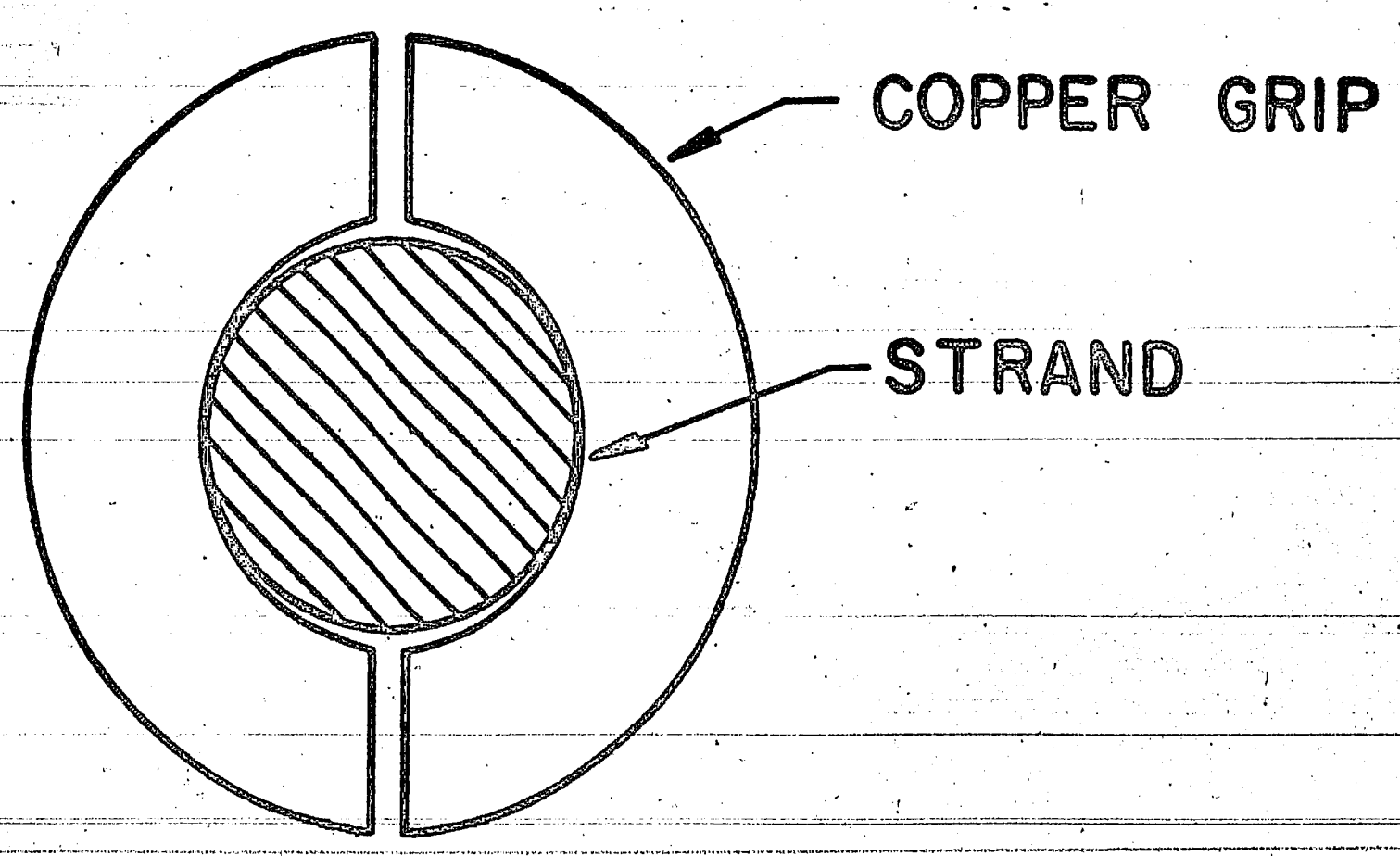
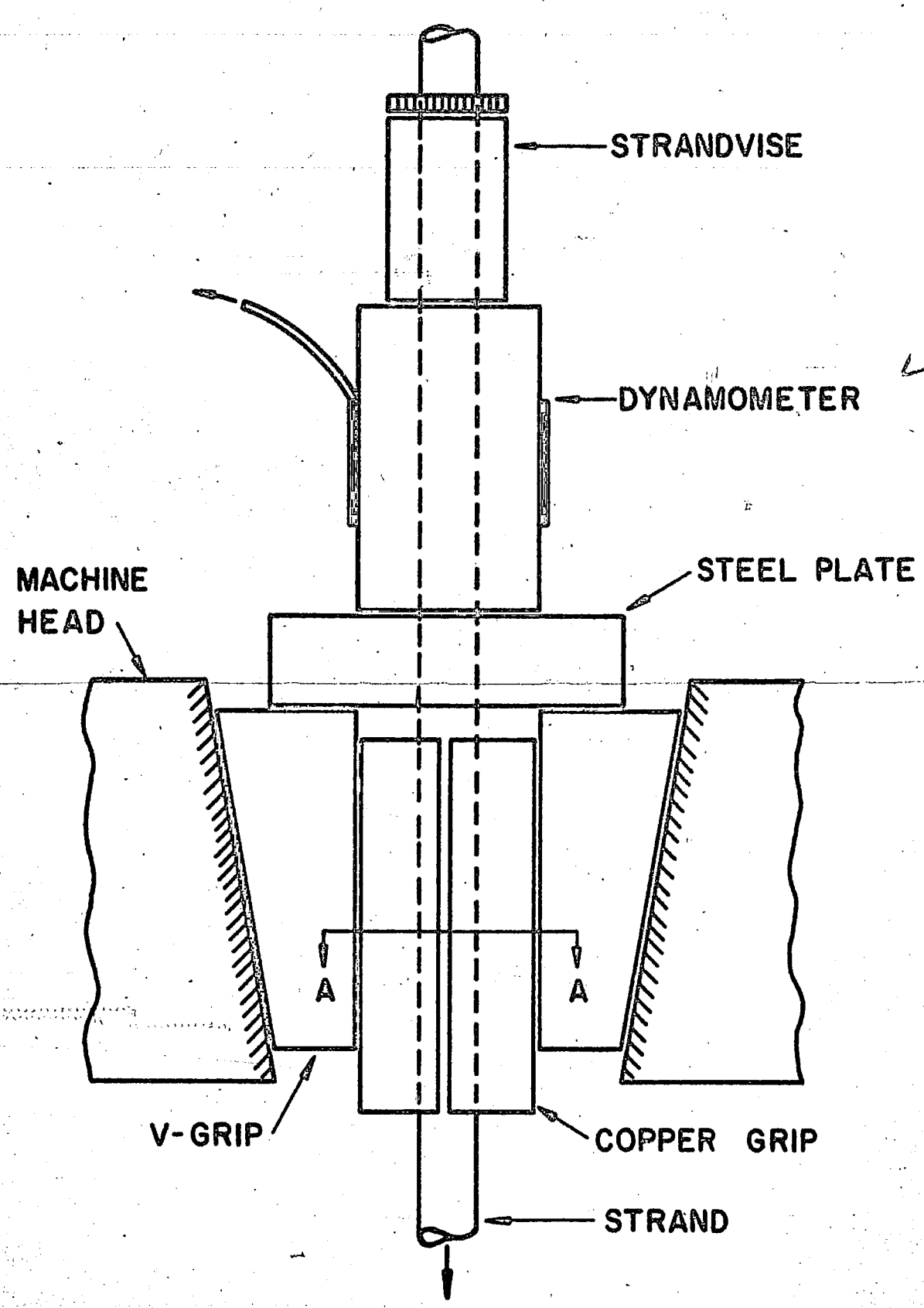

Fig. 2 Yield Strength for Prestressing Strand



ENLARGED SECTION A-A

Fig. 3 Gripping of Test Specimens - Static Tests

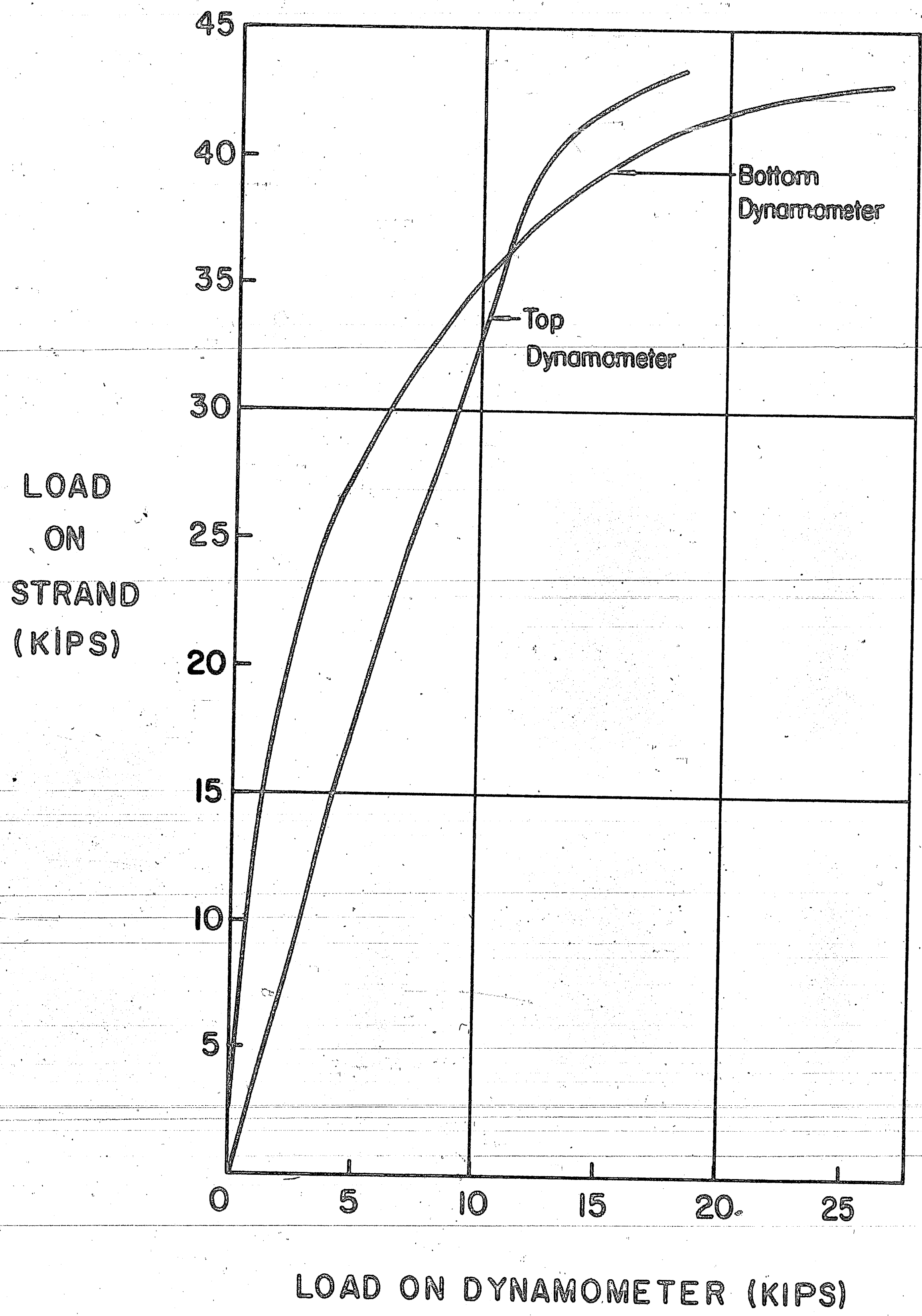

Fig. 4 Effectiveness of the Copper Grips

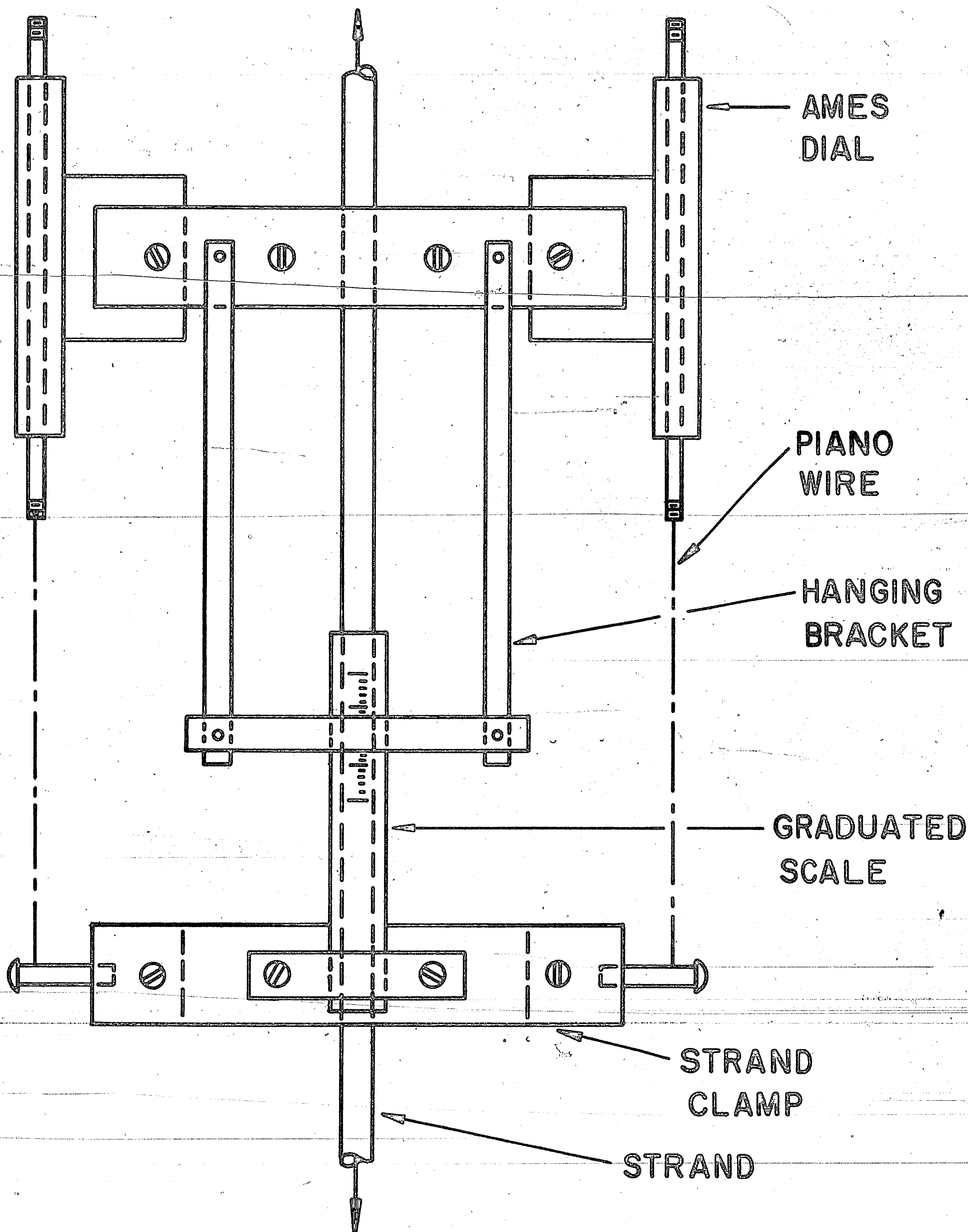
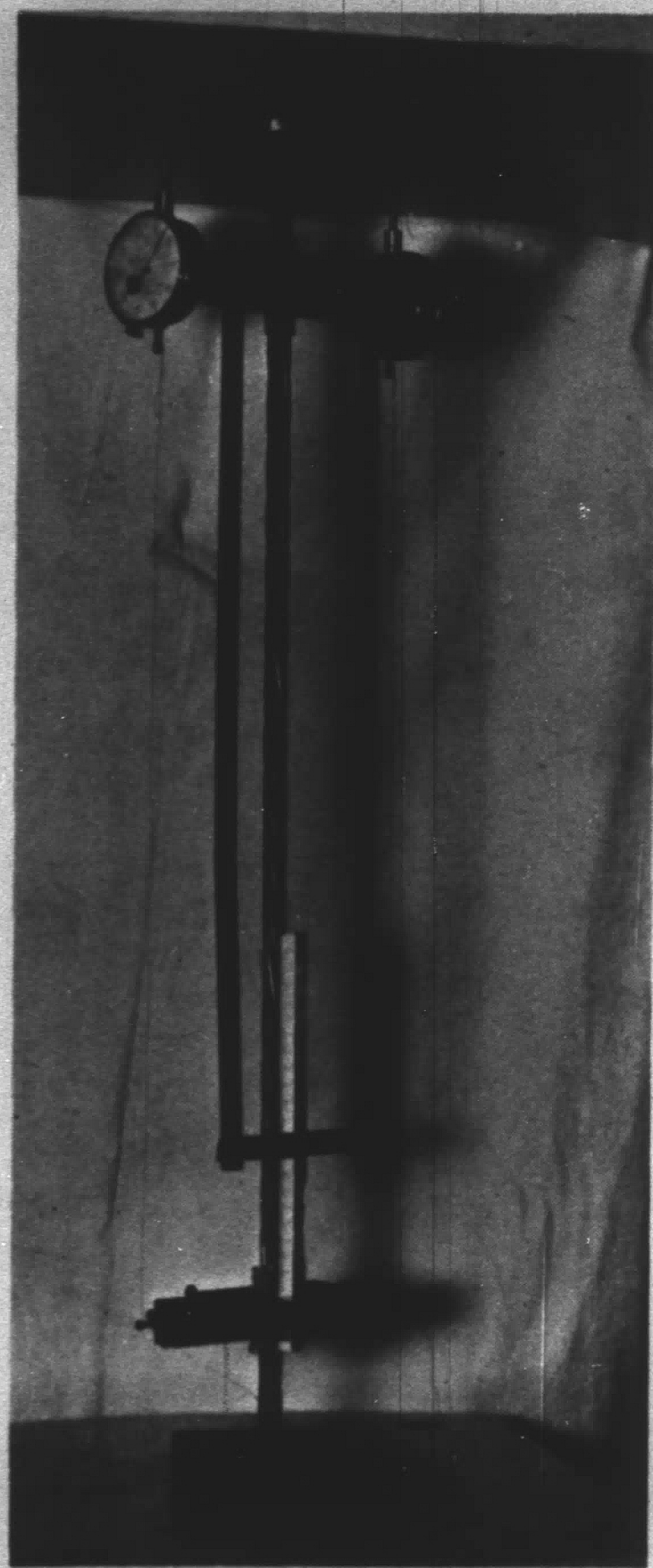
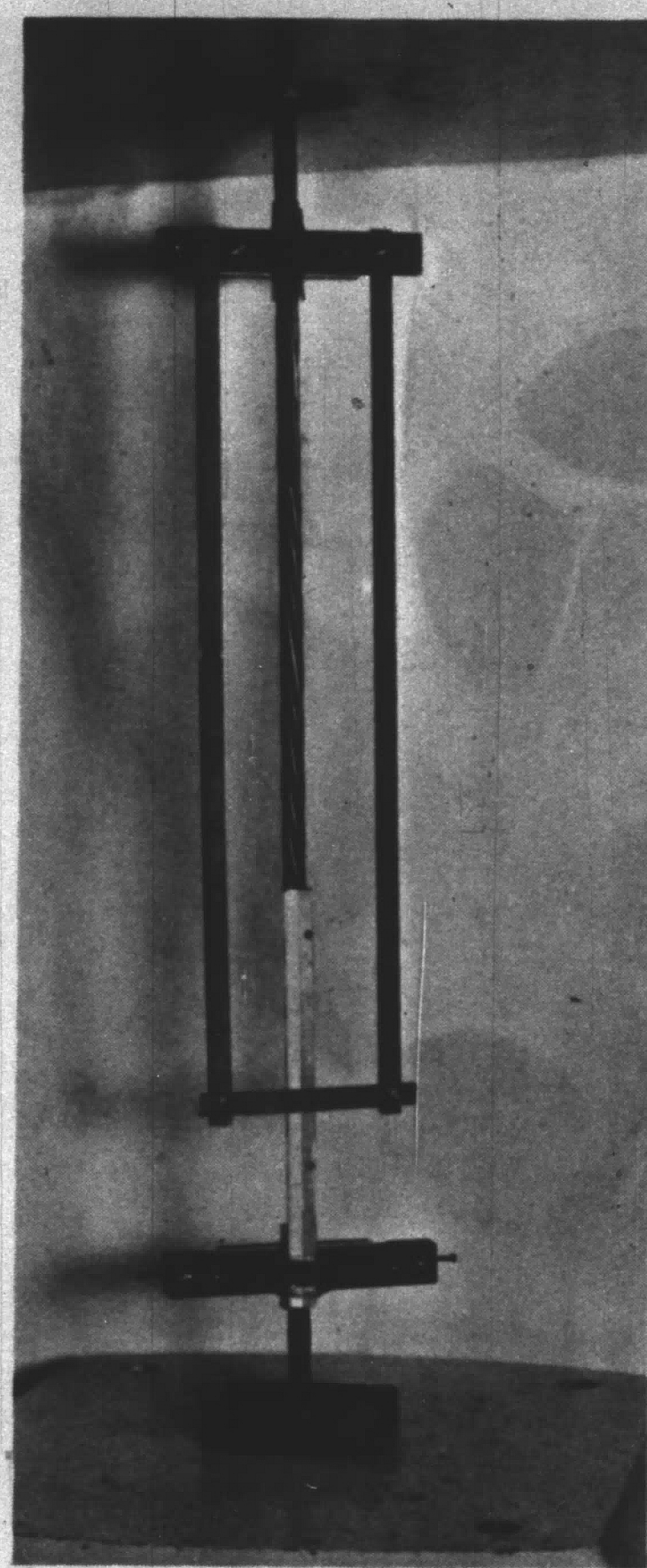

Fig. 5 Extensometer - Static Tests





(a) Initial



(b) Near failure

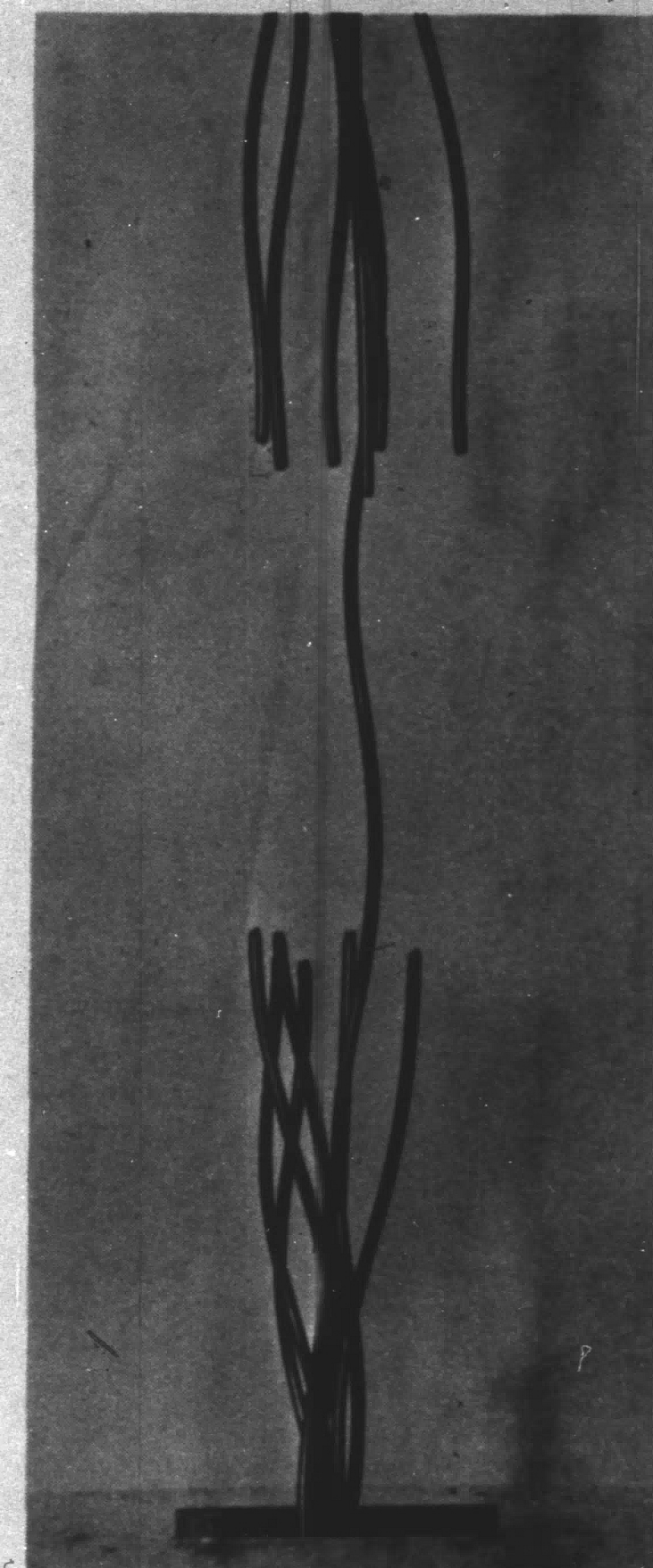

(c) Failure

Fig. 6 Static Test Setup with Extensometer



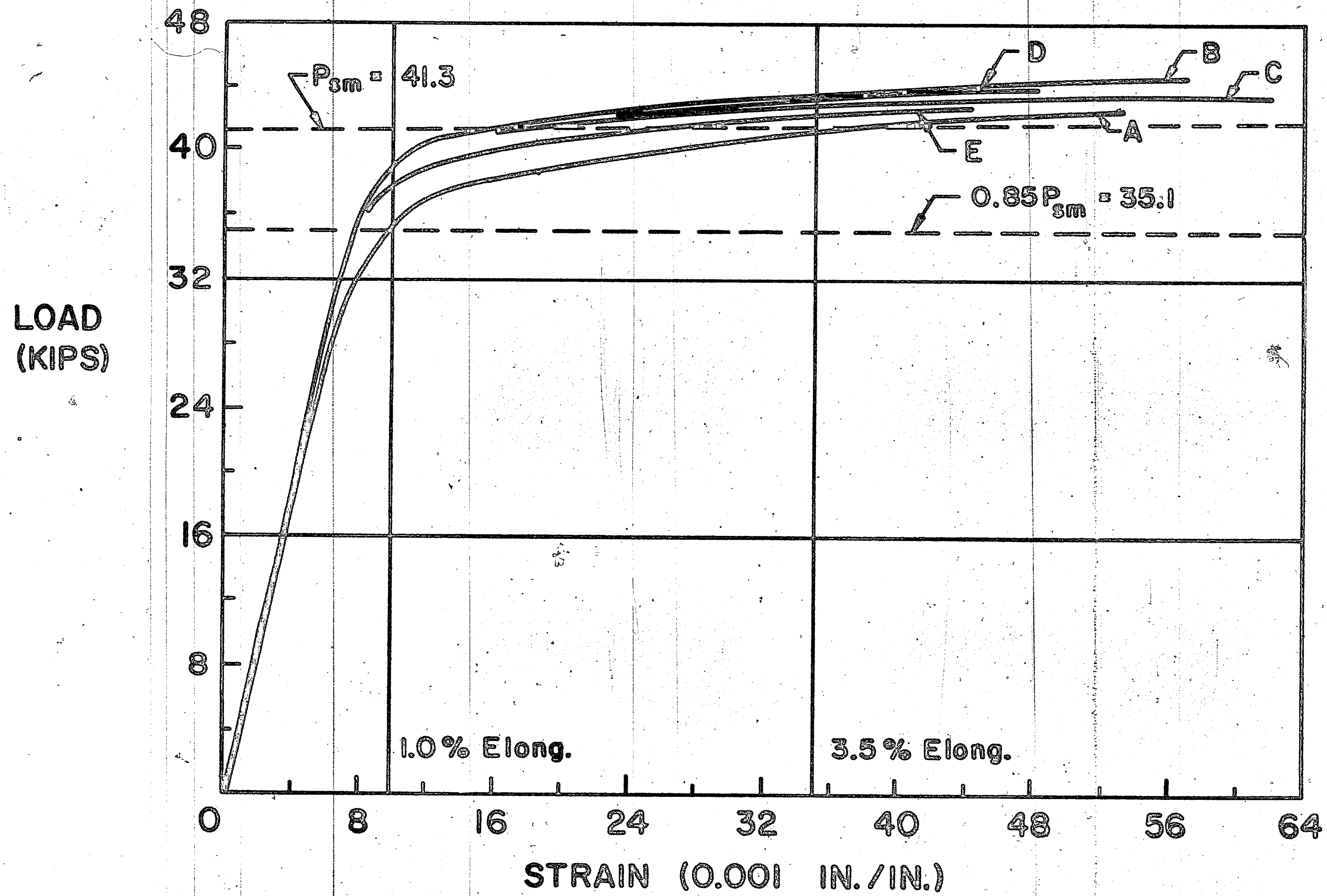

Fig. 7 Typical Load-Strain Relationships for Prestressing Strand

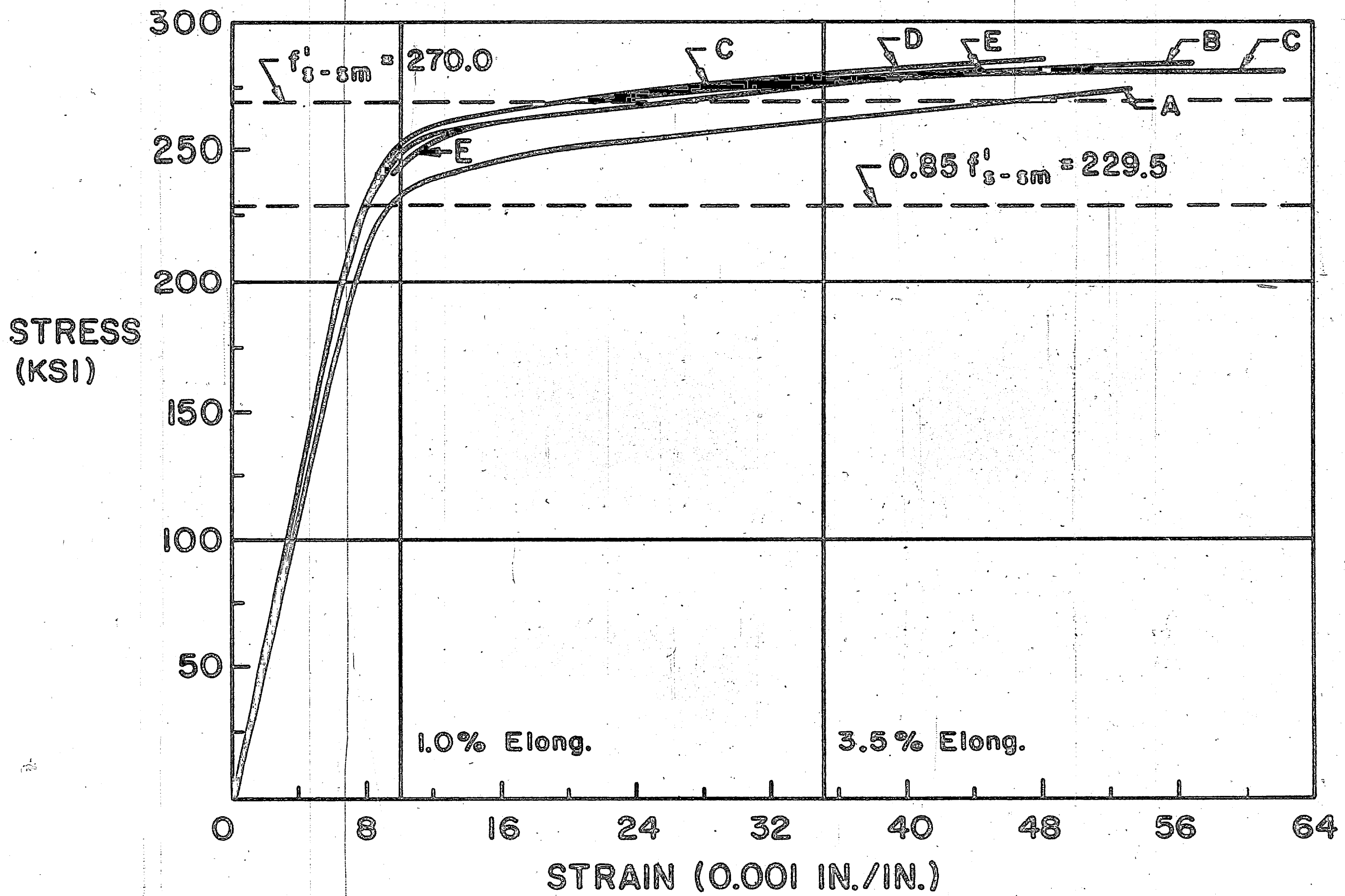

Fig. 8 Typical Stress-Strain Relationships for Prestressing Strand

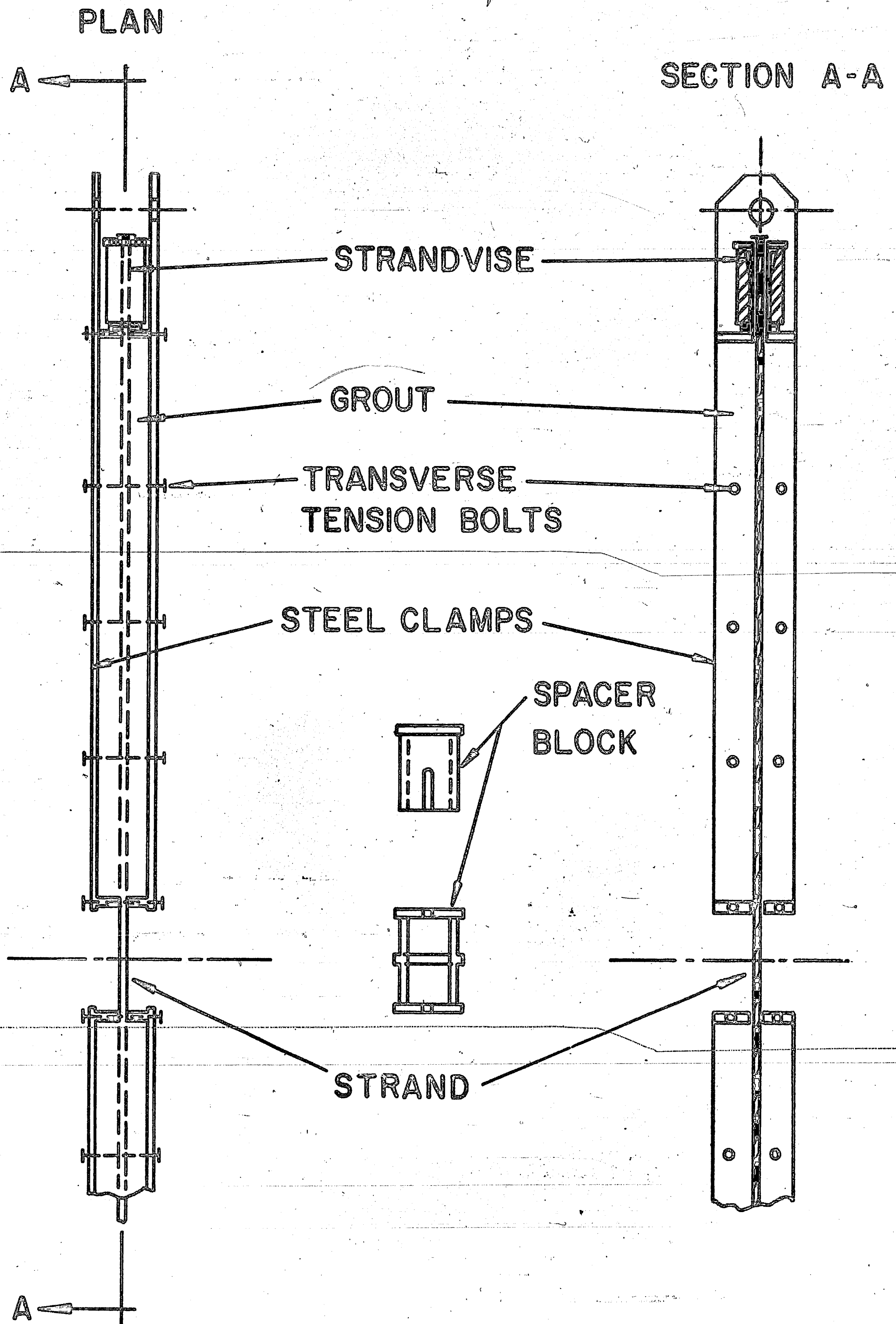

Fig. 9 Fatigue Test Specimens

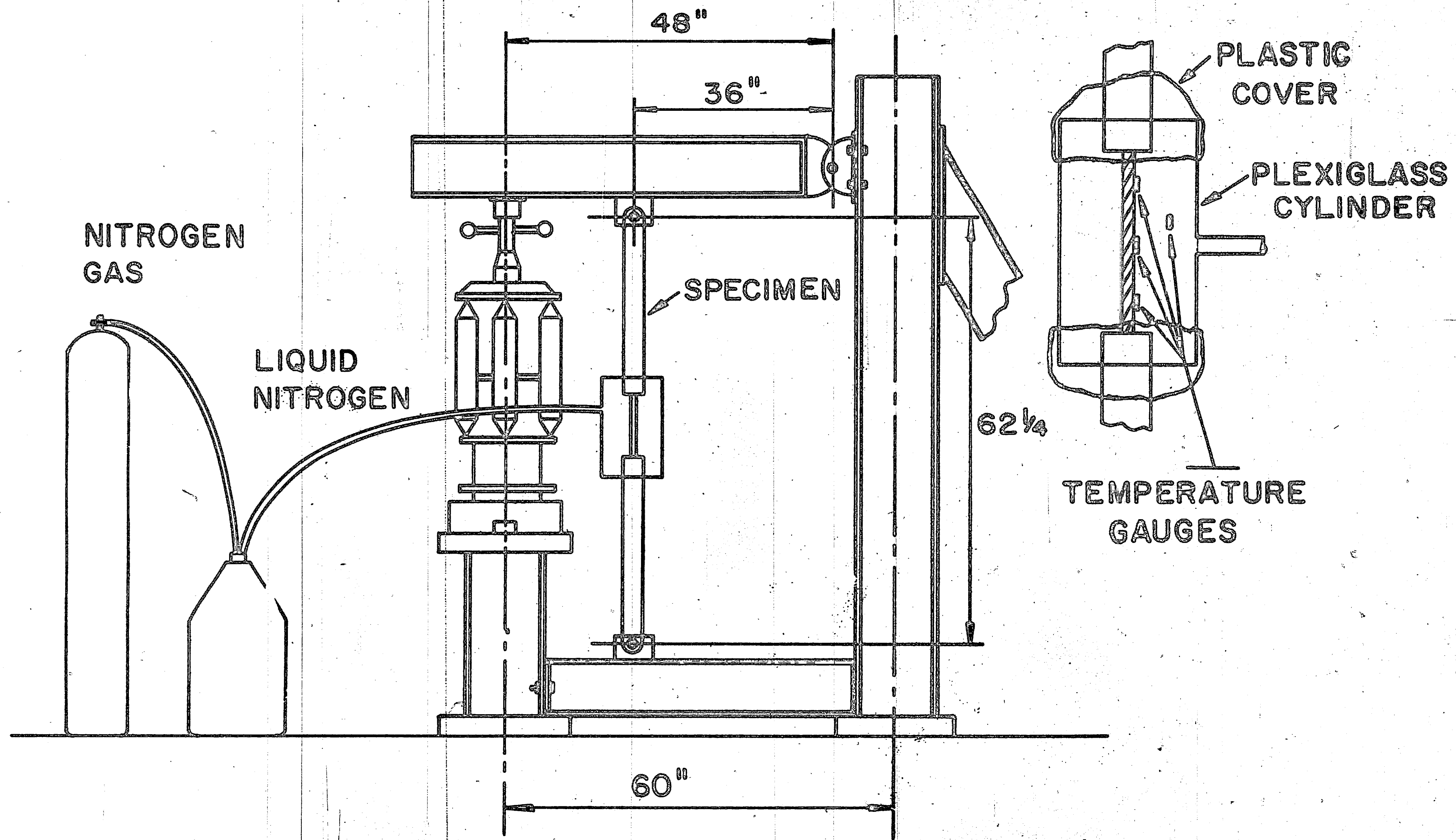
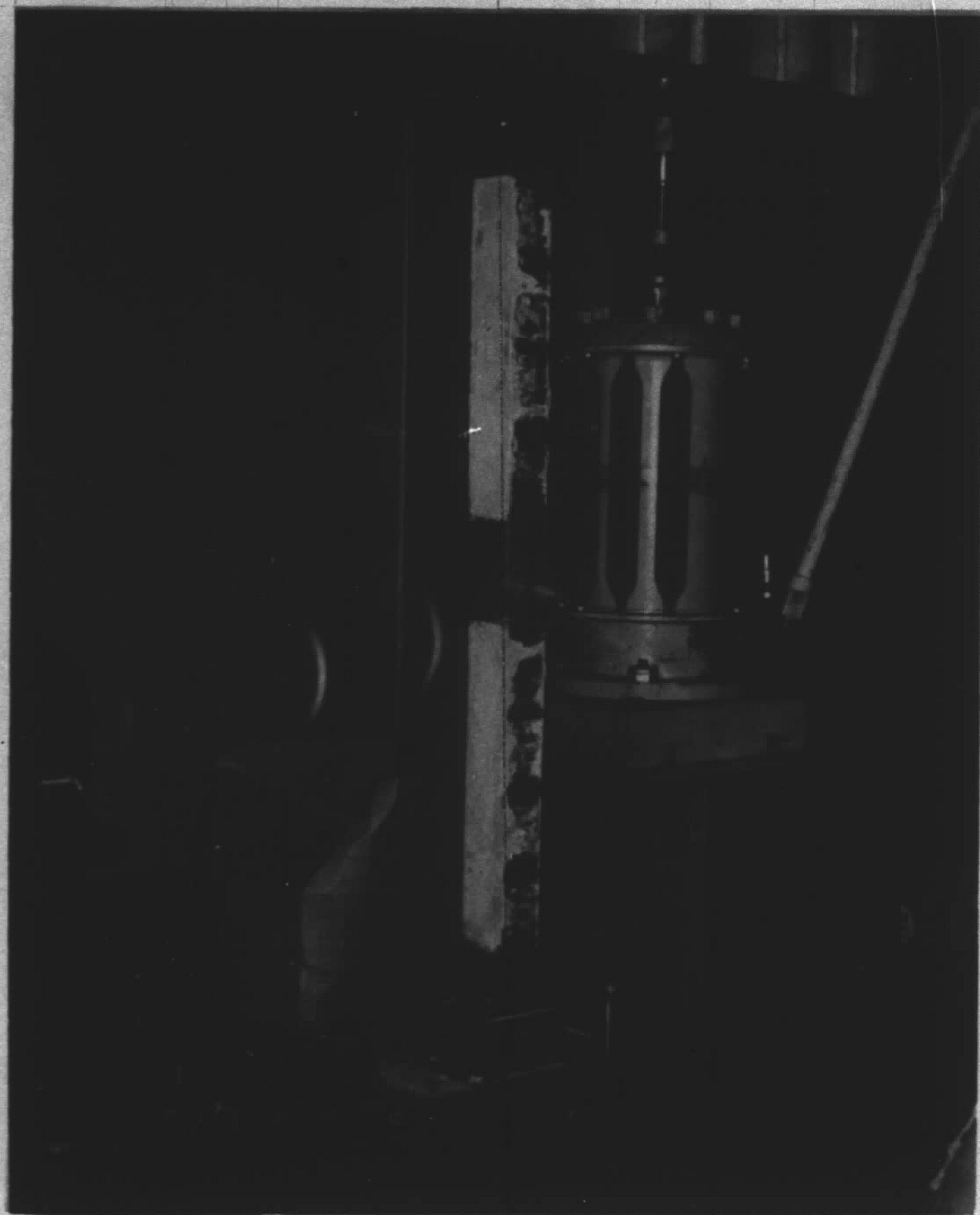

Fig. 10 Fatigue Test Setup





(a) Laboratory temperature (70°F)



(b) Low Temperature (0°F)

Fig. 11 Specimens in Fatigue Test Setup



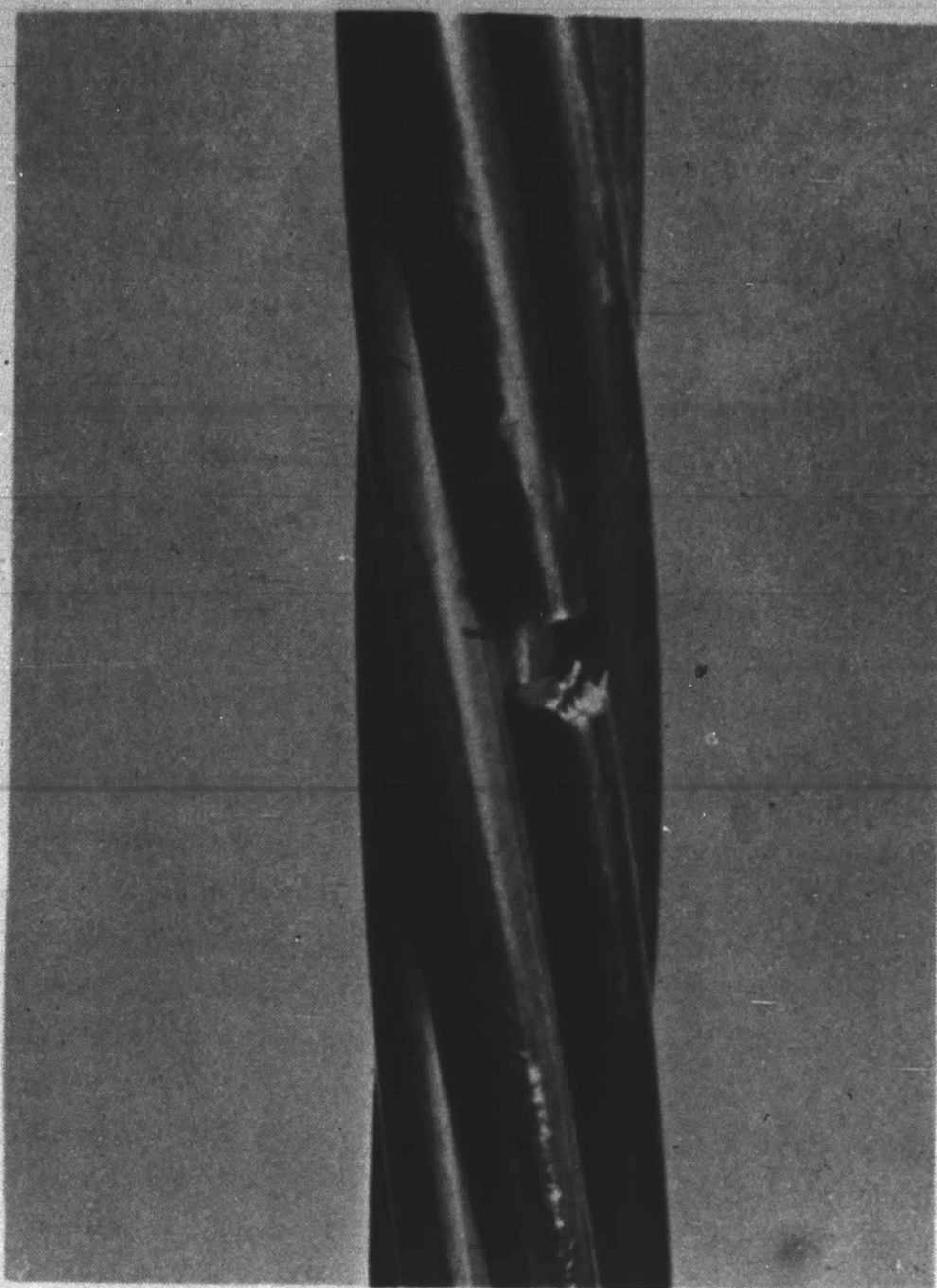

(a) Typical fatigue failure



(b) Failure surface

Fig. 12 Mode of Strand Failure in Fatigue Tests



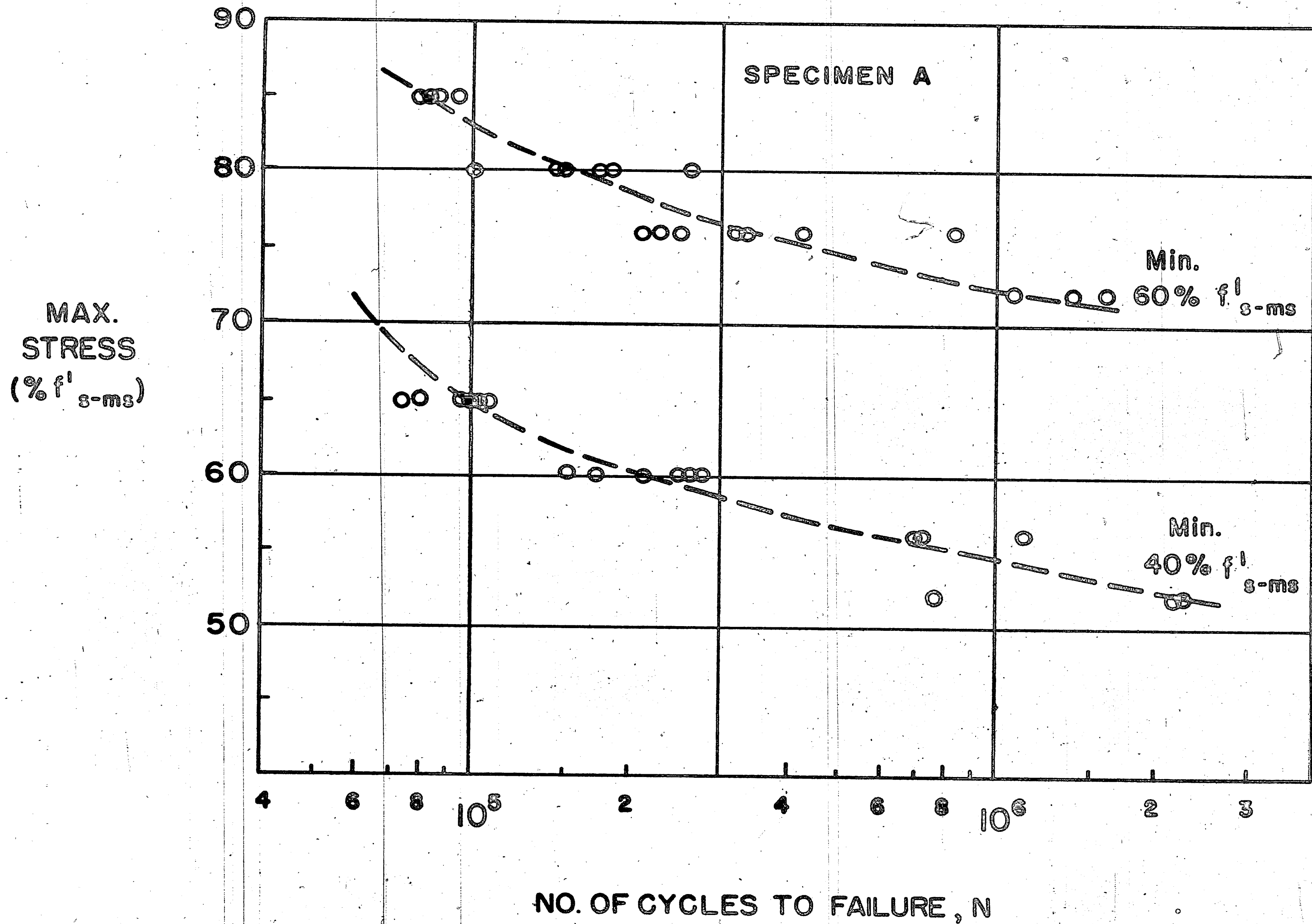

Fig. 13 Maximum Stress Level vs. Fatigue Life, Specimen A

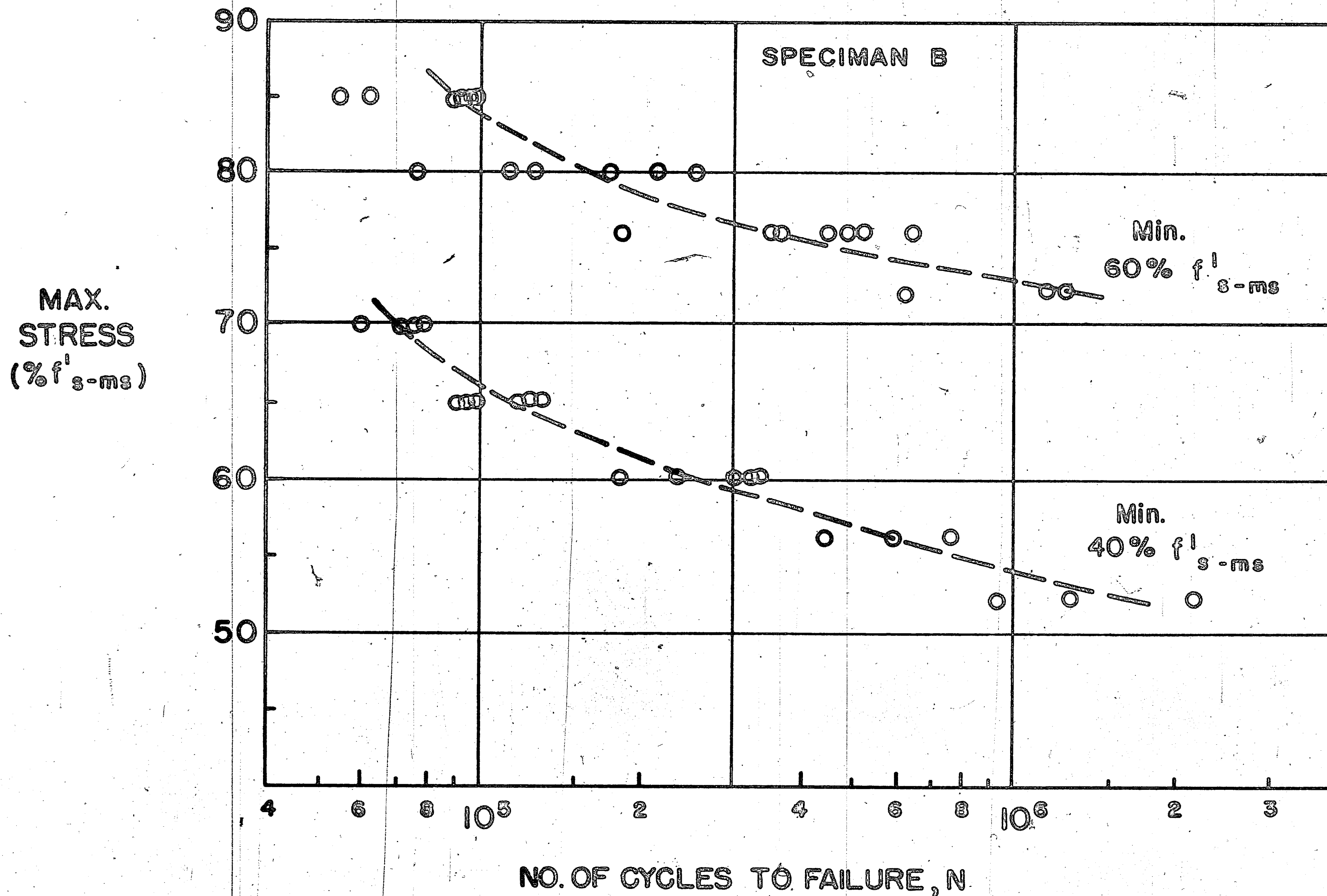

Fig. 14 Maximum Stress Level vs. Fatigue Life, Specimen B

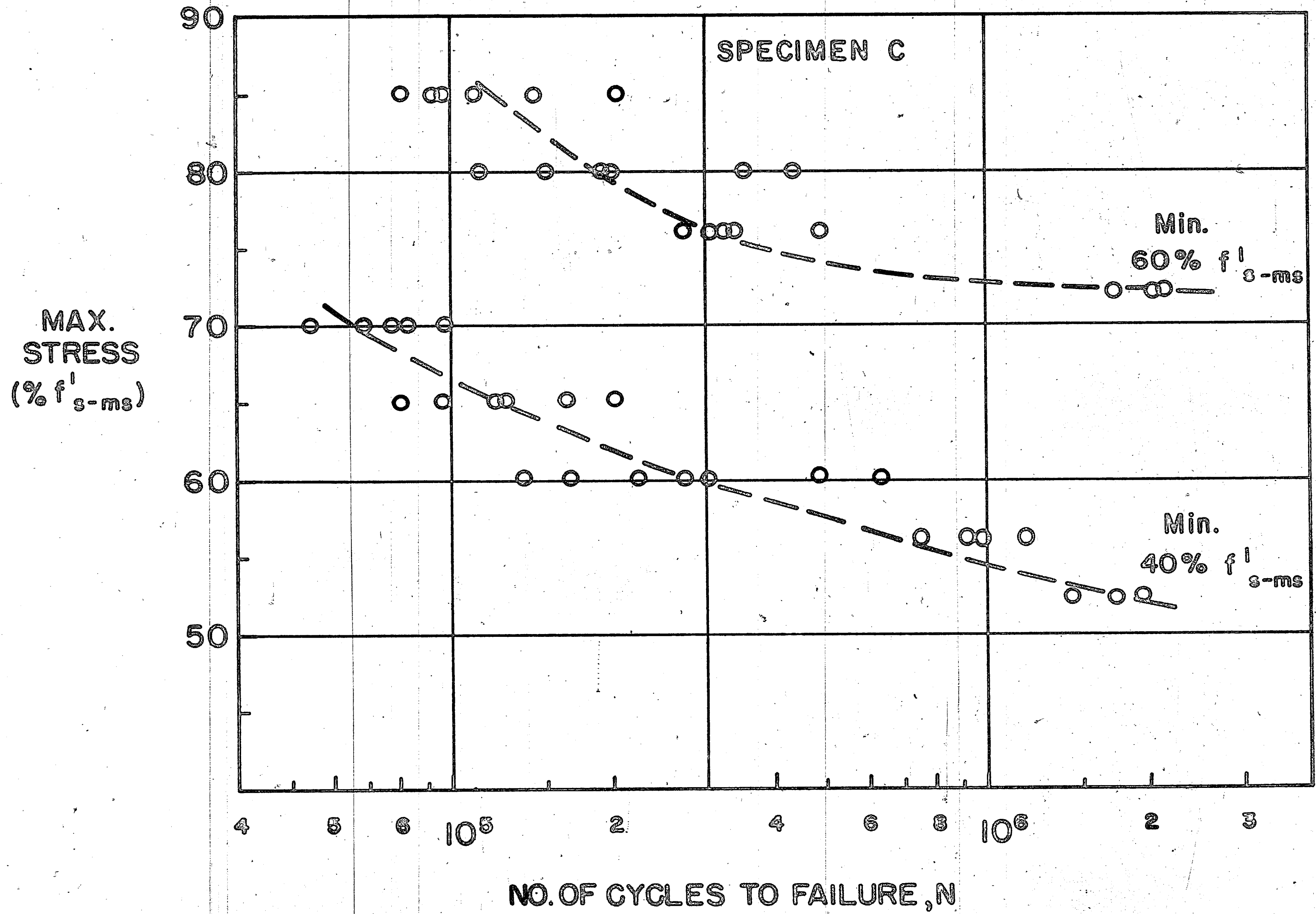

Fig. 15 Maximum Stress Level vs. Fatigue Life, Specimen C

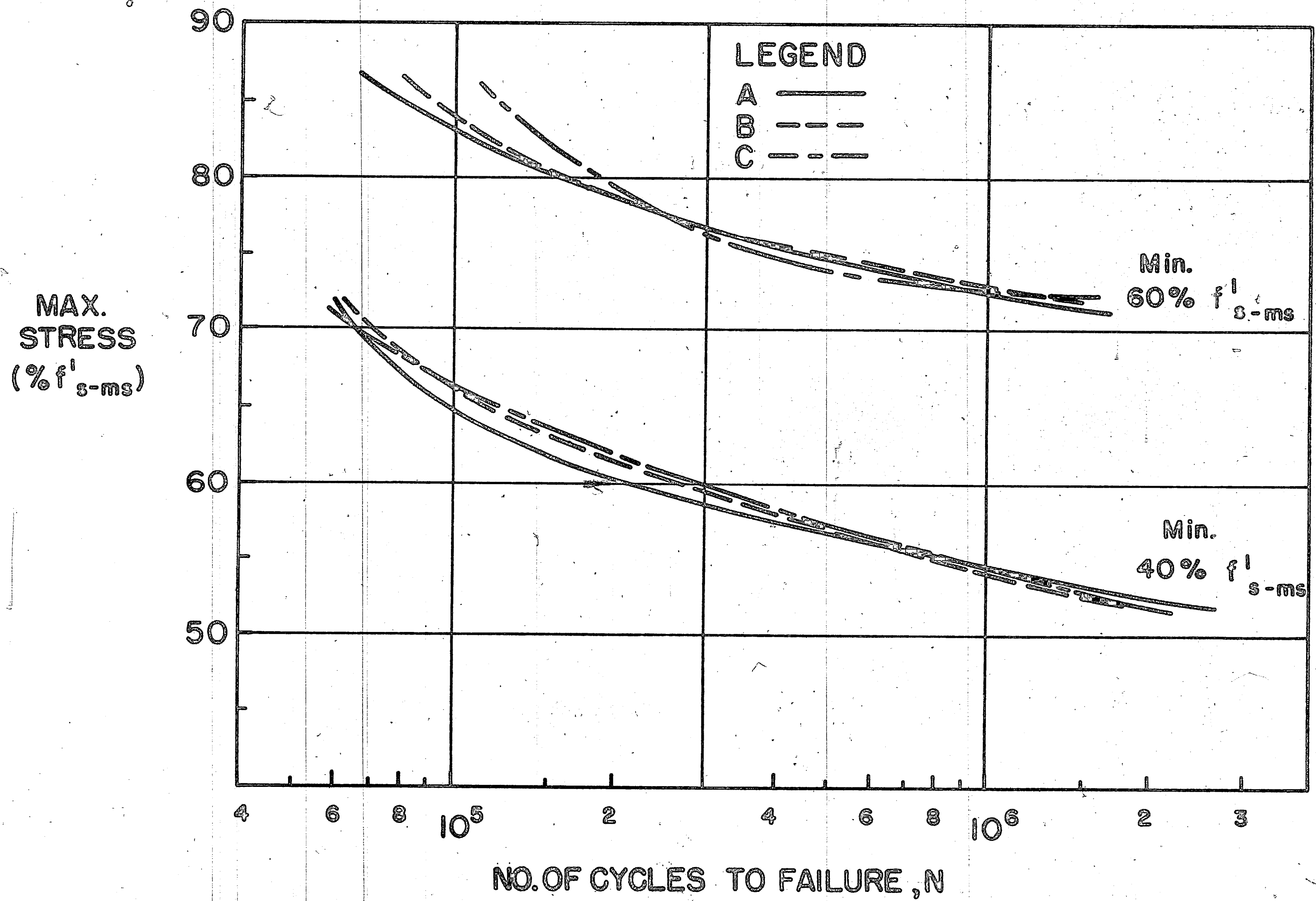

Fig. 16 Comparison of Fatigue Life of Various Manufacturers



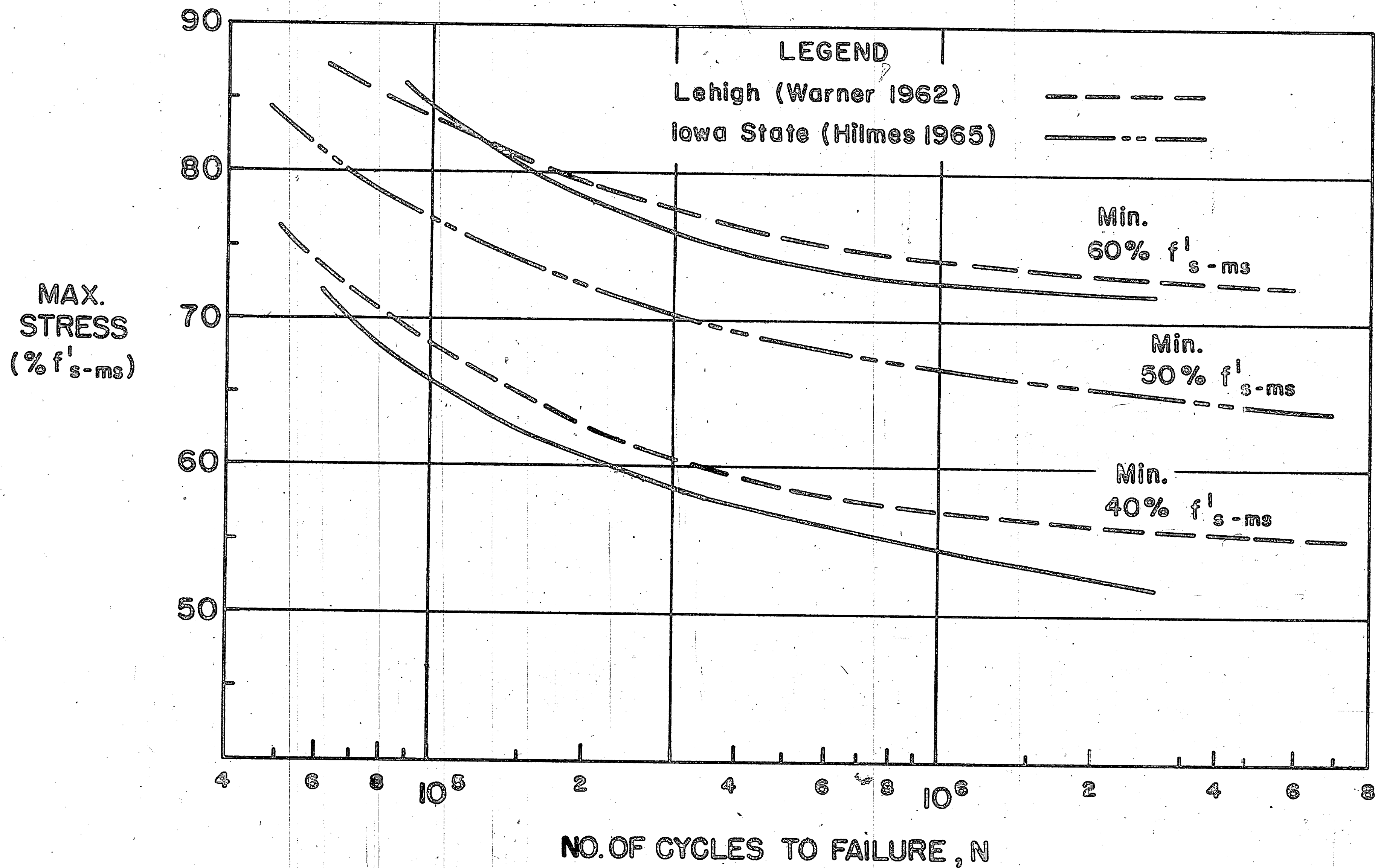

Fig. 17

Comparison of Current Tests with Previous Research

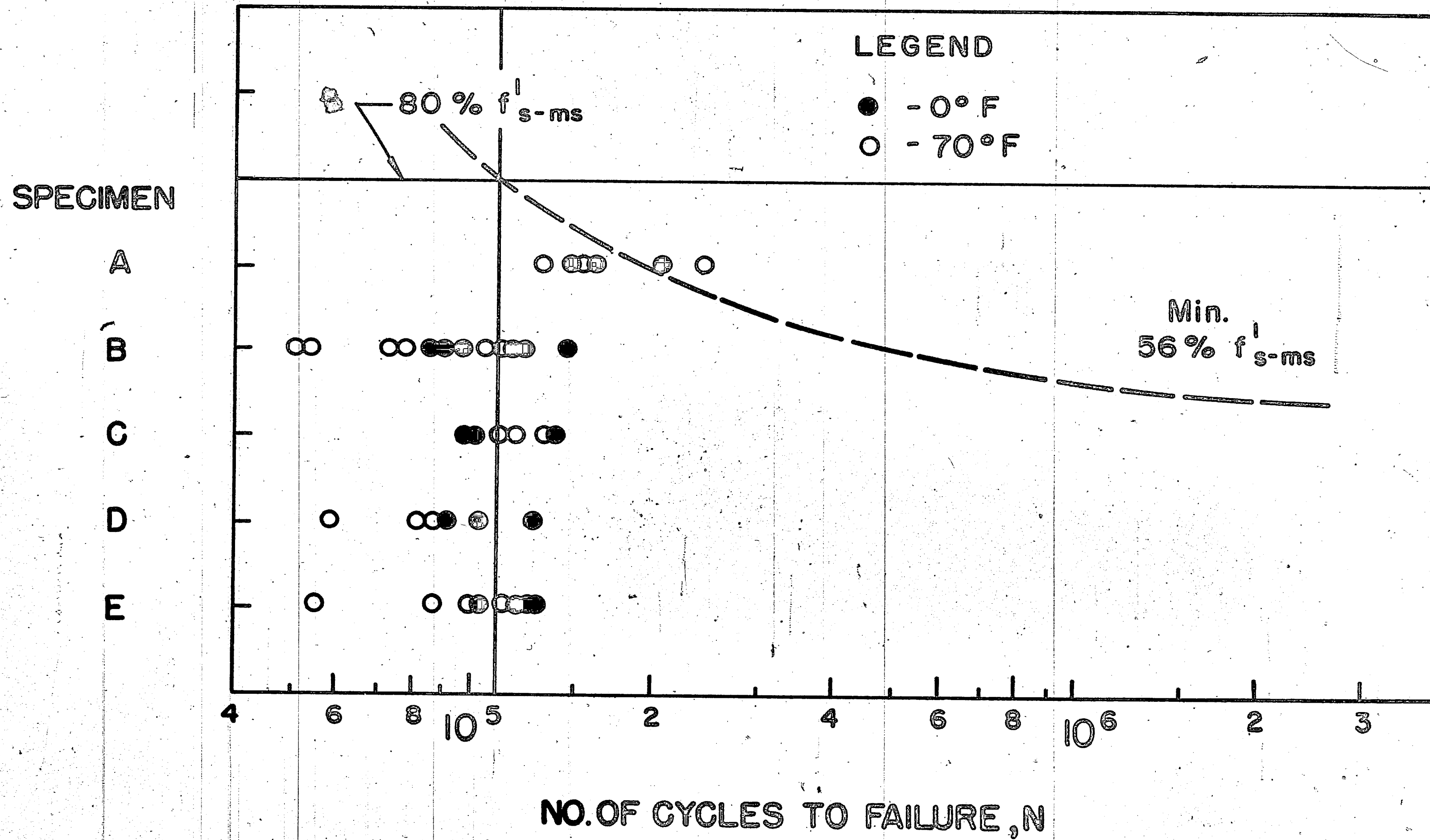

Fig. 18 Effect of Lowering Temperature on Fatigue Life

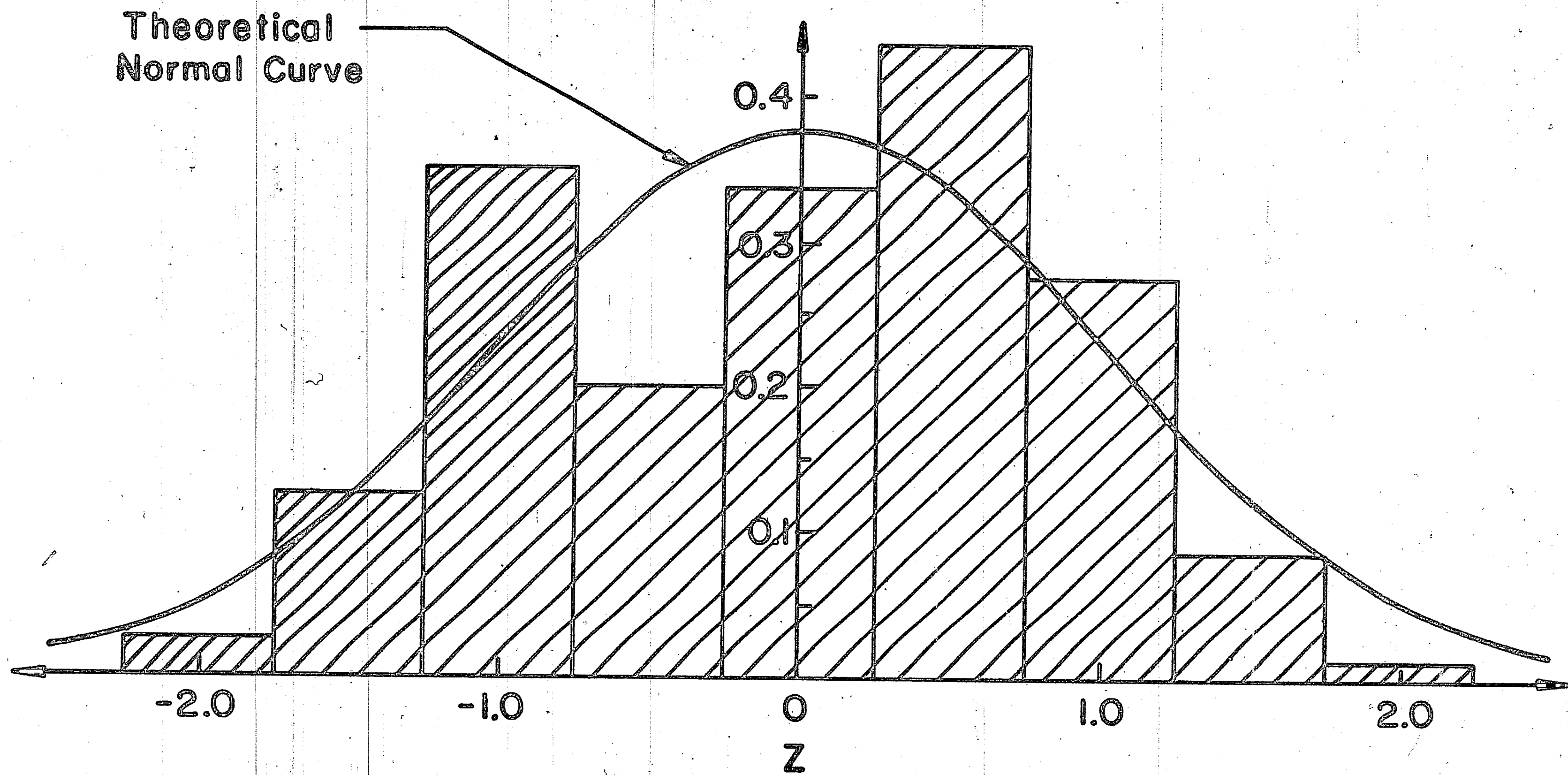

Fig. 19 Frequency Distribution of Grouped Constant Cycle Test Data

$$\overline{\text{Log N}} = 6.356 - 0.1373 R_s + 0.00303 R_s^2$$

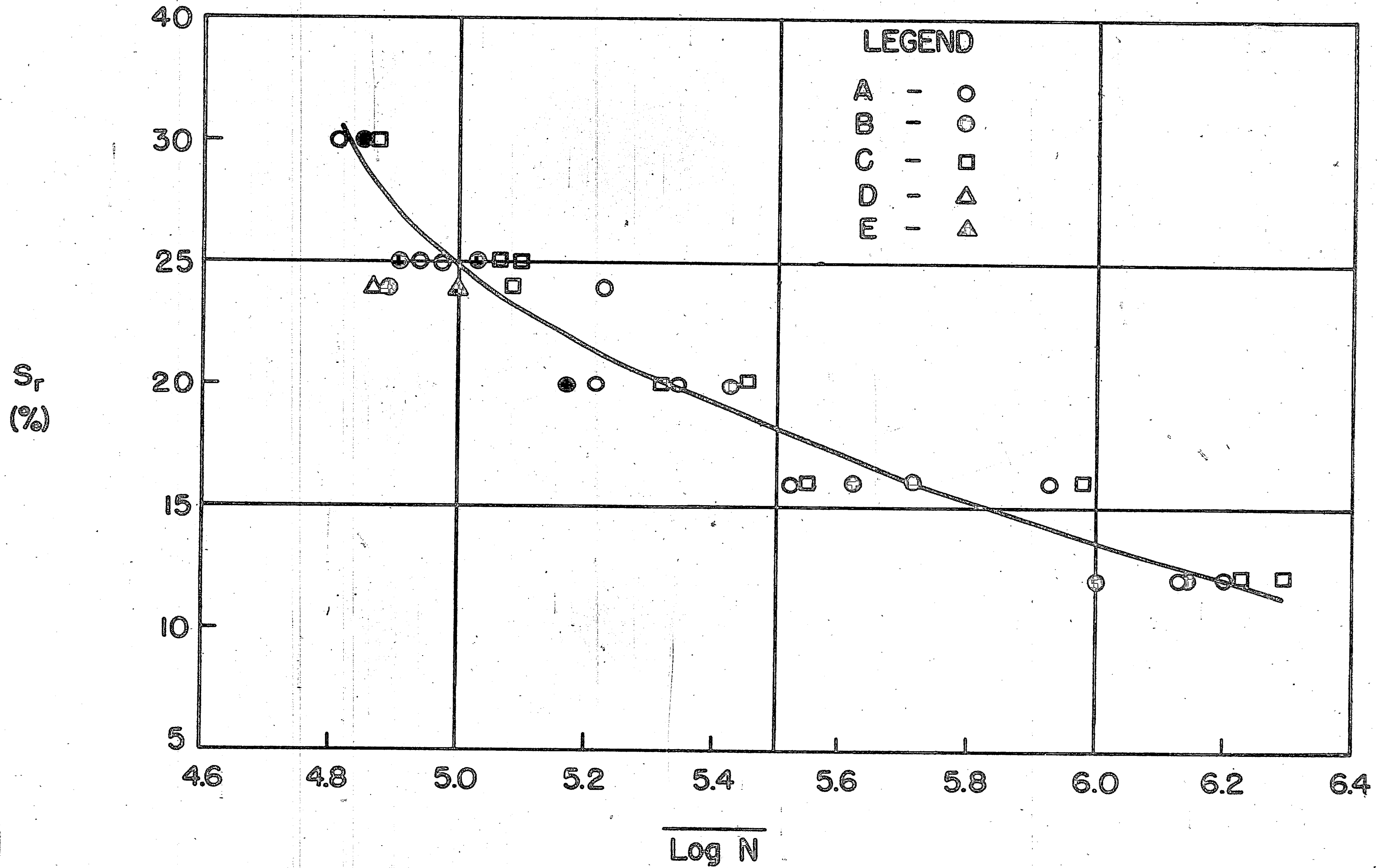

Fig. 20  $\overline{\text{Log N}}$  vs. Load Range  $R_s$

$$D = 0.153 - 0.0035 R_s$$

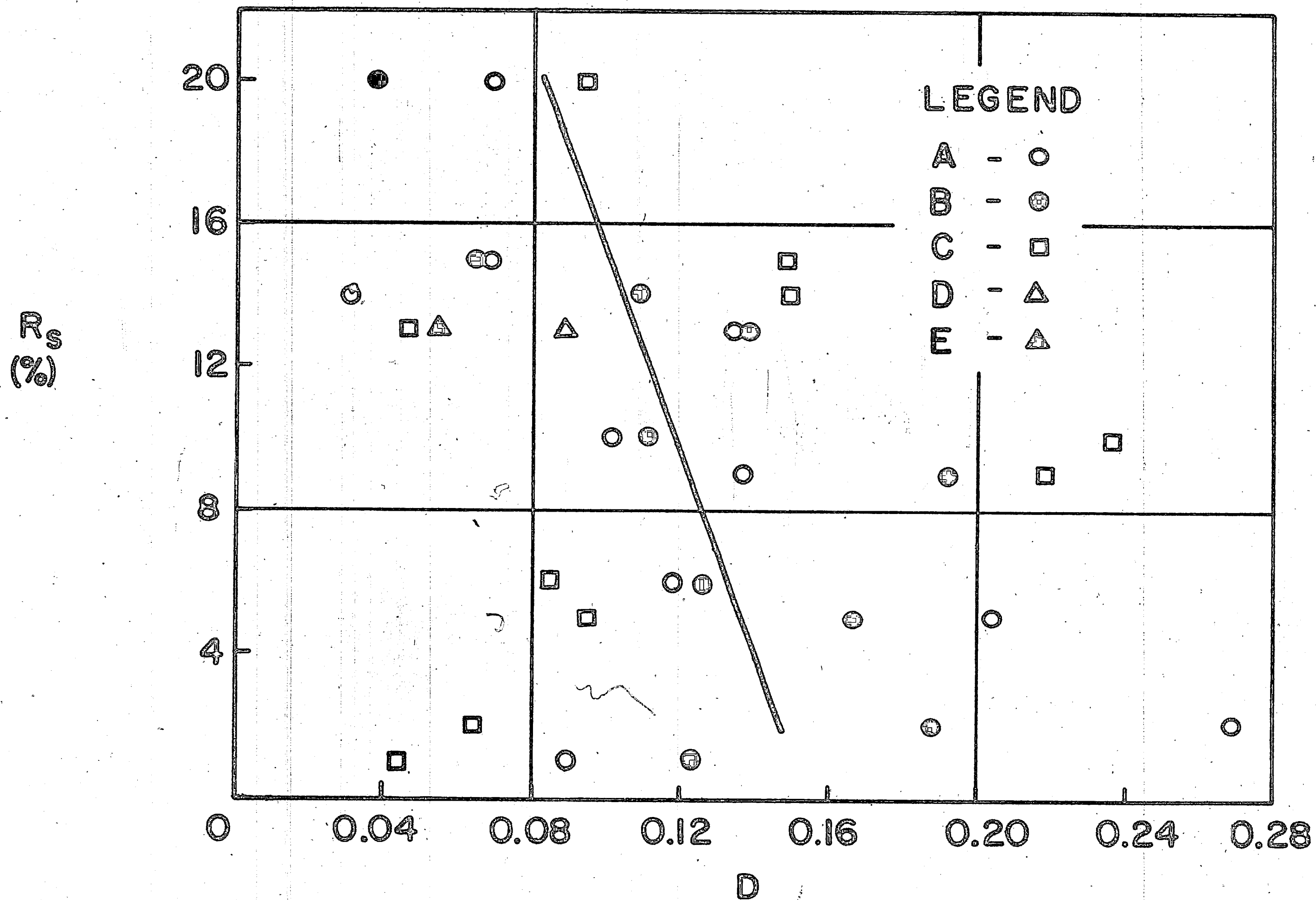

Fig. 21 Standard Deviation D vs. Load Range  $R_s$



$$\overline{\text{Log N}} = 8.213 - 0.2077 S_r + 0.00316 S_r^2$$

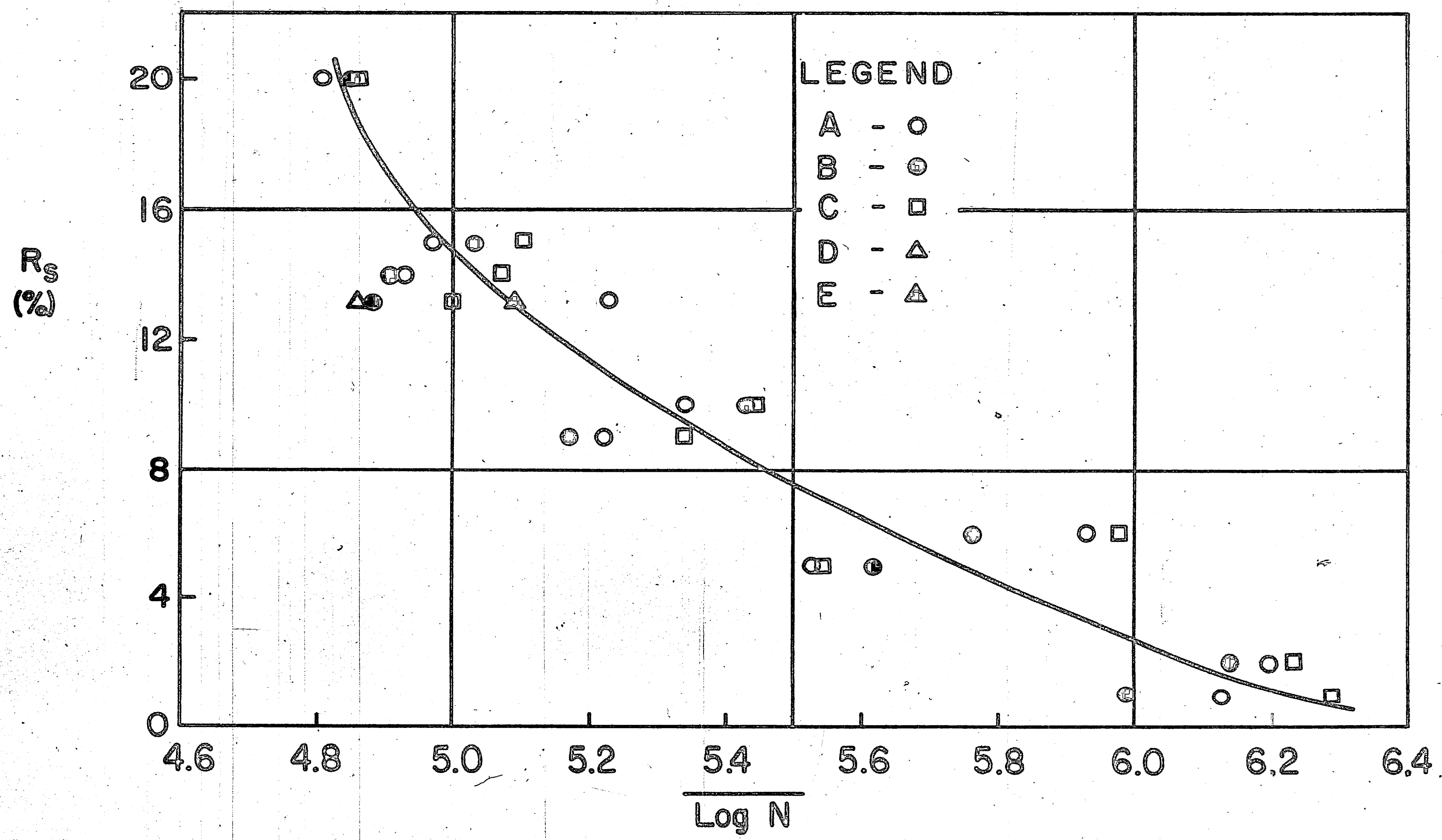

Fig. 22  $\overline{\text{Log N}}$  vs. Stress Range S<sub>r</sub>

$$\overline{\text{Log N}} = 9.998 - 3.566 \text{ Log } S_r$$

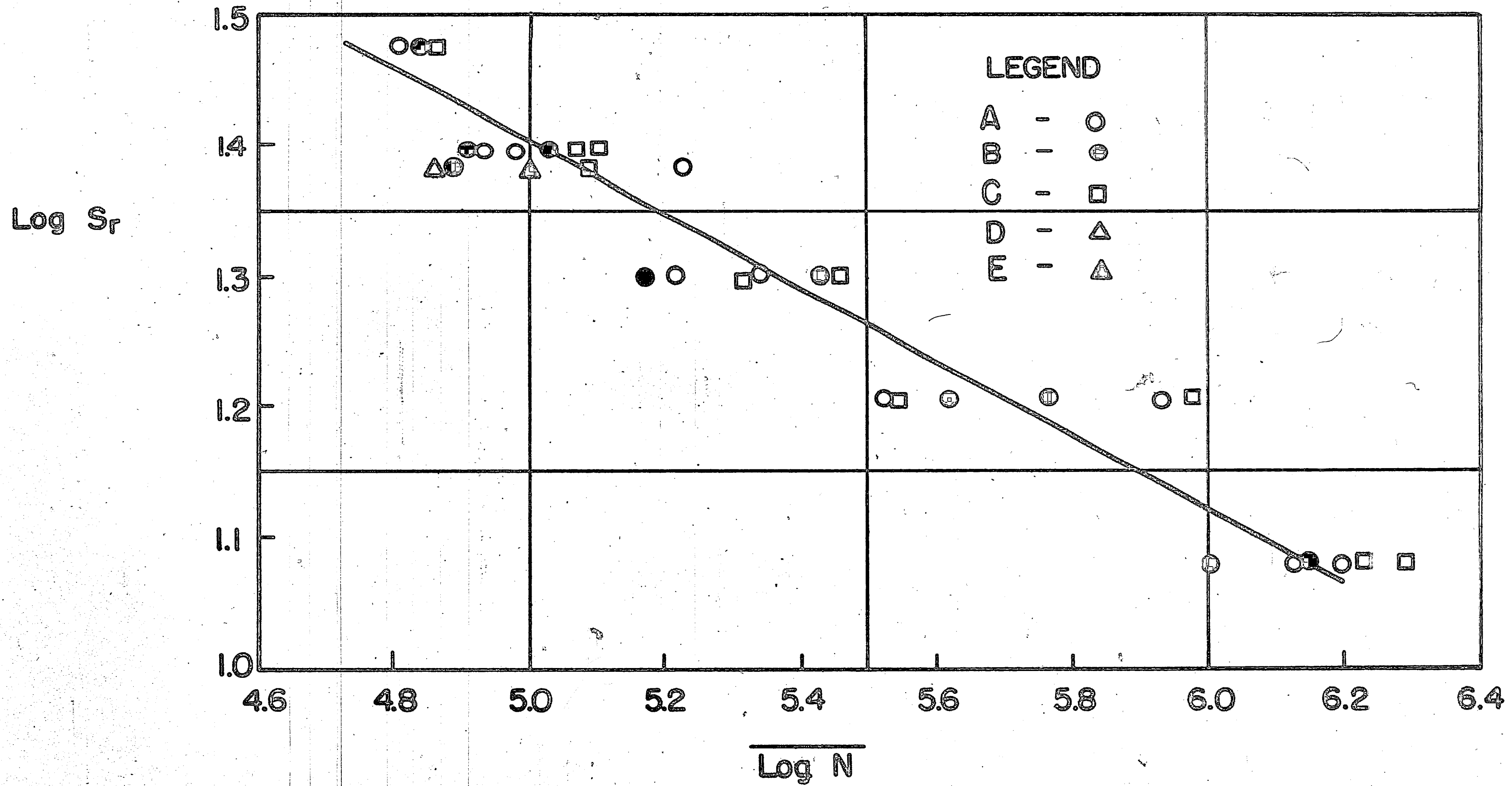

Fig. 23  $\overline{\text{Log N}}$  vs.  $\text{Log } S_r$

10. REFERENCES

1. Warner, R. F., Hulsbos, C. L.  
PROBABLE FATIGUE LIFE OF PRESTRESSED CONCRETE  
FLEXURAL MEMBERS  
Lehigh University Fritz Engineering Laboratory  
Report 223.24A, 1962
2. Hilmes, J. B., Ekberg, C. E.  
STATISTICAL ANALYSIS OF THE FATIGUE CHARACTERISTICS  
OF UNDERREINFORCED PRESTRESSED CONCRETE FLEXURAL  
MEMBERS  
Iowa Engineering Experiment Station, Iowa State  
University, 1965
3. Lane, R. E., Ekberg, C. E.  
REPEATED LOAD TESTS ON 7-WIRE PRESTRESSING STRANDS  
Progress Report 223.21, Fritz Engineering Laboratory,  
Lehigh University, 1959
4. Nuwaysir, F. S.  
FATIGUE STUDY OF PRESTRESSED CONCRETE BEAMS AND THEIR  
COMPONENTS  
Fritz Engineering Laboratory (unpublished report),  
Lehigh University, 1958
5. Nordby, G. M.  
FATIGUE OF CONCRETE - A REVIEW OF RESEARCH  
Journal American Concrete Institute, Vol. 30, No. 2,  
August 1958
6. Fisher, J. W., Viest, I. M.  
FATIGUE TESTS OF BRIDGE MATERIALS OF THE AASHO ROAD  
TEST  
Highway Research Board Special Report 66, 1961
7. Preston, H. K.  
WIRE AND STRAND FOR PRESTRESSED CONCRETE  
Prestressed Concrete Institute Journal 1, No. 4:  
30-33, 1957
8. Lin, T. Y.  
DESIGN OF PRESTRESSED CONCRETE STRUCTURES  
2nd Ed. New York, New York, John Wiley and Sons, Inc.,  
1963

9. Magnel, G.  
LE BETON PRECONTRAIN  
Vol. IV, 3rd Ed., Editions Fecheyr, Gand, Belgique,  
1953
10. Mood, A. M.  
INTRODUCTION TO THE THEORY OF STATISTICS  
McGraw-Hill, 1950
11. Crow, E. L., Davis, F. A., Maxfield, M. W.  
STATISTICS MANUAL  
Dover Publications, New York, 1960
12. Parker, E. R.  
BRITTLE BEHAVIOR OF ENGINEERING STRUCTURES  
John Wiley & Sons, Inc., 1957
13. Jastrzebski, Z. O.  
NATURE AND PROPERTIES OF ENGINEERING MATERIALS  
John Wiley & Sons, Inc., 1959
14. Forrest, P. G.  
FATIGUE OF METALS  
Addison-Wesley Publishing Company, Inc., 1962
15. Timoshenko, S. P.  
STRENGTH OF MATERIALS (PART II)  
D. Van Nostrand Company Inc., 1955
16. American Institute of Steel Construction  
MANUAL OF STEEL CONSTRUCTION  
6th Ed., American Institute of Steel Construction,  
1963
17. American Society for Testing and Materials  
STRUCTURAL AND BOILER STEEL; FORGINGS; FERRO ALLOYS;  
FILLER METAL  
Part 4, 1964, American Society for Testing and  
Materials, Philadelphia, Pa.
18. Freudenthal, A. M.  
PLANNING AND INTERPRETATION OF FATIGUE TESTS  
Symposium on Statistical Aspects of Fatigue,  
Special Technical Publication No. 121, 1952,  
American Society for Testing and Materials,  
Philadelphia, Pa.



19. Epremian, E., Mehl, R. F.  
INVESTIGATION OF STATISTICAL NATURE OF FATIGUE  
PROPERTIES  
National Advisory Committee for Aeronautics,  
Technical Note 2719, June 1952
20. Müller-Stock, H.  
DER EINFLUSS DAUERND UND UNTERBROCHEN WIRKENDER,  
SCHWINGENDER UBERBEANS FRUCHUNG AUF DIE  
ENTWICKLUNG DES DAUERBRUCHS  
Mitt Kohle und Eisenforsch, Bd. 2, 1938, pp. 83-107
21. Weibull, W.  
DISCUSSION OF REFERENCE (18)  
Symposium on Statistical Aspects of Fatigue,  
Special Technical Publication No. 121, 1952,  
American Society for Testing and Materials,  
Philadelphia, Pa.
22. Hanson, J. M.  
ULTIMATE SHEAR STRENGTH OF PRESTRESSED CONCRETE  
BEAMS WITH WEB REINFORCEMENT  
Fritz Engineering Laboratory Report No. 223.27B  
(Ph.D. Dissertation), Lehigh University, 1964
23. Brecht, H. E.  
ULTIMATE SHEAR TESTS OF FULL-SIZED PRESTRESSED  
CONCRETE BEAMS  
Fritz Engineering Laboratory Report No. 223.28A  
(Master's Thesis), Lehigh University, 1965
24. Badaliane, R., VanHorn, D. A.  
ULTIMATE FLEXURAL BOND IN BEAMS PRE-TENSIONED WITH  
HIGH-STRENGTH STRAND  
Fritz Engineering Laboratory Report No. 309.1,  
Lehigh University, 1966
25. Grover, H. J., Gordon, S. A., Jackson, L. R.  
FATIGUE OF METALS AND STRUCTURES  
U.S. Government Printing Office, Revised Ed., 1960
26. American Society for Testing and Materials  
A GUIDE FOR FATIGUE TESTING AND THE STATISTICAL  
ANALYSIS OF FATIGUE DATA  
Special Technical Publication No. 91.A, American  
Society for Testing and Materials, Philadelphia, Pa.

## 11. V I T A

The author, the fourth child and only son of Edward Tide and Augustine Tide (nee Waldbauer), was born at Killaly, Saskatchewan, on October 9, 1938.

He took all of his primary and secondary education at Neudorf, Saskatchewan, graduating in June, 1956. In the Fall he was appointed, by the Canadian Army, to a Regular Officer Training Plan candidacy at the University of Manitoba. Upon receiving a Bachelor of Science degree in Civil Engineering, in June 1961, he was commissioned as an Officer in the Canadian Army (Regular), Corps of Royal Canadian Engineers.

The two years following commissioning he served in several administrative and technical positions at various garrisons around Canada, including a six month tour of duty with Le Royal 22<sup>e</sup> Regiment, La Citadelle, Quebec, P.Q. In June 1963, he was posted to the Engineer Company, Canadian Contingent, United Nations Emergency Force in the Middle East (Gaza, Palestine). He was employed as a Works and Demolitions Officer while serving overseas. On returning to Canada, in July 1964, he was granted permission to take his release from the Regular Forces.

In September 1964, he was appointed to a Research Assistantship in the Structural Concrete Division, Fritz Engineering Laboratory,

Lehigh University, where he was employed on various research projects concerning composite beam action, and fatigue of prestressing strands.

The author is a member of the Engineering Institute of Canada, the American Concrete Institute, the American Society of Civil Engineers, and he is a Registered Engineer in Manitoba.