

1961

The effect of fastener pitch in long structural joints

Roger McKee Hansen
Lehigh University

Follow this and additional works at: <https://preserve.lehigh.edu/etd>



Part of the [Civil Engineering Commons](#)

Recommended Citation

Hansen, Roger McKee, "The effect of fastener pitch in long structural joints" (1961). *Theses and Dissertations*. 3060.
<https://preserve.lehigh.edu/etd/3060>

This Thesis is brought to you for free and open access by Lehigh Preserve. It has been accepted for inclusion in Theses and Dissertations by an authorized administrator of Lehigh Preserve. For more information, please contact preserve@lehigh.edu.

Photoduplication Service
 Lehigh University
 Bethlehem, Pa.

Job No. 2-10-11

REQUISITION FOR PHOTODUPLICATION SERVICES

Item No.	Type of Reproduction	Complete Description	Unit Price	Item Price
1	Microfilm (negative)	Hansen, Roger McKee The effect of fastener pitch in long structural joints. Thesis (M.S.) L.U.-Dept. of Civil Engineering.		

Microfilm reel and box
 Microfilm minimum charge
 Postage, as required

TOTAL CHARGE

This work is done under the conditions stated on the back of this sheet, to which I agree.

Authorized Signature *[Handwritten Signature]*

Department _____

Account Number _____

Date _____

Personal payment _____

(PREPAYMENT WILL NOT BE ACCEPTED.
 Applicant will be billed by the University on completion of work.)

If non-Lehigh request, name and address of institution:

Is copyright agreement on file? _____

**THE EFFECT OF FASTENER PITCH
IN LONG STRUCTURAL JOINTS**

by

Roger McKee Hansen

A THESIS

Presented to the Graduate Faculty

of Lehigh University

in Candidacy for the Degree of

Master of Science

Lehigh University

1961

This thesis is accepted and approved in partial fulfillment of the requirements for the degree of Master of Science.

5-25-61
(date)

Lynn S. Beedle per L.S.D.
Professor in charge

W. J. Enry
Head of the Department

ACKNOWLEDGMENTS

The author is greatly indebted to Dr. Lynn S. Beedle who, as the professor in charge of the thesis, has provided encouragement, advice, and valuable suggestions during the preparation of the thesis.

Sincere gratitude is extended to Dr. John L. Rumpf whose suggestions have been invaluable. It was on the basis of previous work by Dr. Rumpf that much of this thesis proceeded and his permission to use graphs, charts and other results of his work is greatly appreciated.

The thesis covers parts of a research project on "Large Bolted Joints" currently being carried out at the Fritz Engineering Laboratory, Lehigh University. The project is sponsored financially by the Pennsylvania Department of Highways and the Bureau of Public Roads. Technical guidance has been provided by a committee of the Research Council for Riveted and Bolted Structural Joints.

The large test specimens were fabricated by Bethlehem Steel Company and appreciation is expressed to Messrs. E. F. Ball, K. de Vries, J. J. Higgins, and A. Schwartz for their interest and cooperation.

Preparation of testing set-ups at the Fritz Laboratory was directed by Mr. S. J. Errera and Mr. K. R. Harpel. Appreciation is due them and the many technicians working under their direction.

Mr. S. E. Dlugosz, who is a Research Assistant assigned to the project, helped conduct part of the experimental investigations for this thesis and his help is appreciated.

The manuscript was typed by Miss Grace Mann and the drawings were made by Mr. S. A. Gawlick. Their help in the last stage of preparing this thesis has been invaluable.

TABLE OF CONTENTS

v

	Page
1. INTRODUCTION	1
1.1 General	1
1.2 Review of Literature	3
1.3 Objective of Thesis	4
2. THEORETICAL SOLUTION	5
2.1 Origin	5
2.2 Development of Equilibrium Equation	5
2.3 Development of Compatibility Equations	7
2.4 Calibration Procedures	9
2.5 Solution of Equations	11
3. BEHAVIOR OF LONG BOLTED JOINTS	14
3.1 Theoretical and Experimental Work	14
3.2 Other Experimental Work Related to the Variation of Pitch	16
4. BEHAVIOR OF LONG RIVETED JOINTS	19
4.1 Application of Theory	19
4.2 Theoretical and Experimental Work	19

	vi
	Page
5. THEORETICAL AND EXPERIMENTAL RESULTS	23
5.1 Connector Forces	23
5.2 Ultimate Strength and Unbuttoning Factor	25
5.3 Bolt Deformation	28
5.4 Distribution of Connector Forces	29
5.5 Comparison of Ductility	30
6. SUMMARY AND CONCLUSIONS	32
7. NOMENCLATURE	35
8. TABLES AND FIGURES	37
Table 5.1	38
Figure 2.1 to Figure 2.9	39
Figure 3.1 to Figure 3.2	46
Figure 4.1 to Figure 4.2	48
Figure 5.1 to Figure 5.11	50
9. LIST OF REFERENCES	61
VITA	64

1. INTRODUCTION

1.1 General

One of the many variables affecting the behavior of structural connections is the spacing of the fasteners parallel to the direction of the applied load. This spacing is commonly called the pitch. Some investigations have been concerned with the effect of fastener spacing on the behavior of the connected material⁽¹⁾ but the important factor in this case is the transverse spacing, called the gage. The pitch plays a secondary role in cases where the material failure may be a tear along a sawtooth line through holes of the first and second rows.

In the case of fastener performance, pitch plays a more important part. The design specifications of the American Institute of Steel Construction⁽²⁾ include a section on the spacing of rivets which is of interest at this point. The minimum allowable pitch is set by such things as clearance, driving conditions and fabrication technique. Also, there is a maximum pitch for compression members which is set to prevent local buckling in built up members. However, there is no

provision for maximum pitch in tension members and it would be possible to design a connection with the fasteners at a twelve-inch pitch or more.

Silence on this subject might lead one to believe that the pitch, or overall length of a joint (which is a summation of the pitch distances) has no influence on the behavior of such a connection. Some would say that there should be no concern because a rivet possesses enough ductility to transfer load for any joint configuration. However, this reason has not been substantiated adequately by test.

When design specifications were being prepared for the high strength bolt, a question arose as to whether the bolt was ductile enough to allow similar assumptions. It was reasoned that increased strengths are often achieved by sacrificing ductility. To answer this, experimental investigations were initiated at Lehigh University to evaluate the behavior of long bolted connections. Further tests of similar riveted connections were to provide comparative data about the two types of fasteners. In these tests of full size structural joints the number of fasteners in line was varied but the pitch (with one exception) was always held constant.

1.2 Review of Literature

A search of the literature shows that in both riveted and bolted connection research,^(3,4,5) a reduction in average fastener shear strength has been observed to be associated with increased joint length. This strength reduction is called the "unbuttoning" phenomena. However, from these tests it was impossible to quantitatively evaluate the unbuttoning effect because of the influence of other variables. The Lehigh University program has been able to provide quantitative information as well as qualitative results from long bolted joint tests.^(6,7,8) Some comparison tests have been done with long riveted joints.⁽⁹⁾

A number of theoretical explanations of joint behavior have also been proposed but unfortunately most of these deal with joints in the elastic range and are not applicable to ultimate strength studies.

The most extensive work relating to the ultimate strength of connections was that done for the Aluminium Development Association of England.⁽¹⁰⁾ Although this work pertained to aluminum connections with aluminum or steel rivets, it is of great value in understanding the mechanics of joint behavior

beyond the elastic range. The effect of pitch was discussed.

A portion of the Lehigh University program has been the development of an analytical solution for the post elastic behavior of steel joints joined with high strength bolts.⁽¹¹⁾ This solution has been used to predict successfully the ultimate strength of joints tested in the experimental part of the program. The method can be used for a theoretical analysis of the effect of varying pitch without the necessity of an extensive full scale test program.

1.3 Objective of the Thesis

It has been shown that there is a lack of information on the effect of pitch and what its contribution to unbuttoning phenomena is. Because unbuttoning is vitally important in long connections, there is a definite need for data on its effects. Nor are there provisions in design specifications which account for or control pitch as related to unbuttoning.

The objective of this thesis is to utilize the theoretical solution⁽¹¹⁾ to study the effects of varying pitch, to compare these results with a limited number of tests of large bolted joints, and to make general recommendations for the control of pitch in design practice.

2. THEORETICAL SOLUTION

2.1 Origin

The method of theoretical investigation was presented previously⁽¹¹⁾ and most of the explanations and developments offered in this chapter have appeared in the original paper. Important equations and developments are repeated in condensed form for convenience of reference and to support the validity of results obtained.

2.2 Development of Equilibrium Equation

The connection to be dealt with is an axially loaded, double shear, butt type tension splice (Fig. 2.1). The analysis will deal with a single gage strip only since it has been shown that the capacity of a large joint, P_J , is equal to the sum of the loads, P_G , carried by each gage strip. The joint has two outer or lap plates, both of thickness t , and an inner or main plate of thickness $2t$.

Each pitch is designated by a subscript of the numbers of the bolts on either side of that pitch, bolts being numbered

1 to n from the free end of the lap plate. Prior to slip the holes are aligned through the plies of each plate. The hole diameter, d_H , is larger than the fastener diameter, d_B , by an amount c , the hole clearance (usually 1/16" for structural connections).

The ultimate load of a bearing type connection is assumed as independent of the slip behavior of the joint. Therefore the joint is assumed to be assembled in bearing (slipped condition). Behavior where load is transferred by friction is regarded as nonessential to the study of the effect of variable pitch on behavior near ultimate load.

The bolt is loaded by bearing on each plate and transfers that load across the plane of shear via the shear resistance of its shank. The total load carried by any bolt is equal to the force transferred out of the main plate by that bolt. Figure 2.2 indicates the bolt forces and the forces acting in the various regions of the main and lap plates.

Taking either the main plate or the lap plates as a free body (Fig. 2.2), the equilibrium equation for forces in the horizontal direction is written as follows:

$$\sum F_H = P_G - R_1 - R_2 \cdot \cdot \cdot - R_n = 0 \quad (2.1)$$

To solve for these forces, $n-1$ additional, independent equations are needed. These will come from deformation conditions.

2.3 Development of Compatibility Equations

Certain reference points are set up to help develop the $n-1$ deformation equations required in solving for the unknown bolt forces. The plate reference points are shown in Fig. 2.1 as solid dots. These points are on the edges of the gage strip at the centerline of each aligned hole.

When the inner and outer plates move with respect to one another, the hole reference points are misaligned by an amount called the hole offset, Δ . Connections assembled in bearing with no applied load will have all hole offsets equal to c , the hole clearance. As load is applied, the hole offsets are no longer equal because each pitch elongates a different amount.

The hole offsets, Δ , are not equal to the bolt deformation. It is clear that when slip occurs the hole offsets equal the hole clearance, c , but the bolts have no deformation. The bolt deformation, actually due to shearing and bending is idealized as shown in Fig. 2.3.

It has been shown ⁽¹¹⁾ that a hole offset Δ and a bolt offset δ are related by the following expression:

$$\Delta_1 = c + \delta_1 + \lambda_{i1} + \lambda_{o1} \quad (2.2)$$

where λ_{i1} = the hole elongation due to tensile loading in the main plate

and λ_{o1} = the hole elongation due to tensile loading in the lap plate

and where δ includes bearing deformations of the plates and bolts.

The deformations of the bolts and the longation of the plates in the various pitches must be compatible with one another. The compatibility equations are developed with the help of Fig. 2.4 that shows the edge view of a joint and the plate reference points. The elongation of the pitch between any two bolts is denoted by the letter e .

Equating dimensions along the upper and lower dimension lines and eliminating the pitch lengths there result $n-1$ equations of the form:

$$\Delta_1 + e_{21} = e_{12} + \Delta_2 \quad (2.3)$$

It has been shown⁽¹¹⁾ that these equations involving hole offsets can be written as follows:

$$\begin{aligned}
 \delta_1 + e'_{21} &= e'_{12} + \delta_2 \\
 \delta_2 + e'_{32} &= e'_{23} + \delta_3 \\
 &\vdots \\
 &\vdots \\
 &\vdots \\
 \delta_n + e'_{nm} &= e'_{mn} + \delta_n
 \end{aligned}
 \tag{2.4}$$

where e' = the pitch elongation measured between the bearing surfaces of any two adjacent holes.

Equations 2.4 are the $n-1$ compatibility equations which, expressed in terms of R 's, may be solved simultaneously with the equilibrium condition (Eq. 2.1) to provide the unknown bolt forces R . To effect such a solution the functional relation of loads and deformations for bolts and plate must be determined. These relations are found through calibration tests of single bolts and plates.

2.4 Calibration Procedures

a. Bolt Shear Calibration

Bolt shear calibration must be done on bolts of the same

dimensions, basic properties, and heat treatment as those used in a prototype joint. Because the bolt offset and bearing deformations always occur together, they are lumped together in the quantity called the "calibration bolt offset", δ .

A single hole connection called a shear jig is used to shear the bolt. The shear jig shown in Fig. 2.5 was loaded in a testing machine and corresponding deformations or "calibration bolt offsets" were determined from the relative movement of the testing machine heads. Further explanations of the test procedure may be found in Refs. 11 and 12.

An average of results of bolt shear calibration for D-Lot bolts⁽¹²⁾ is plotted in Fig. 2.6. This curve provides the relationship between bolt offset and load.

b. Plate Calibration

Plate calibration is done by testing a duplicate section of one gage strip and recording the tension - elongation behavior of one pitch length. Since the load is uniform along the length, the quantity e' is equal to the value of e .

The dimensions of the plate calibration specimens are tabulated in Fig. 2.7. The main and lap plates of the prototype joints were always two one-inch plies so the load on the calibration test specimen was doubled to give the load P_G for the two inch strips. The results are plotted in Fig. 2.8.

2.5 Solution of Equations

Knowing the load-deformation relations for bolts and plates, one may proceed with a graphical trial and error solution of forces within the hypothetical joint. Since the joint is symmetrical, one need only solve for one-half of the joint though the solution may be continued through the entire connection. An illustration of the method is shown in Fig. 2.9 using assumed calibration curves.

The plate and bolt calibration curves are plotted to the same scale on a large sheet of graph paper. The plate curve is traced on a sheet of transparent paper and inverted as shown in Fig. 2.9. The inverted curve corresponds to the main plate, M, in the connection and its origin is set at the ordinate, P_G (the desired gage load).

For an assumed value of R_1 (the first bolt in the connection), the corresponding bolt offset, δ_1 , is determined from the bolt calibration curve, B. The elongation of the first pitch in the lap plate, e'_{21} , is read for the same ordinate since the load in that pitch is R_1 . This ordinate also corresponds to the inverted ordinate ($P_G - R_1$), which is the load carried by the main plate in the first pitch, and the main plate elongation, e'_{12} , may be read from M. Thus, the dimensions above and below the horizontal line represent the compatibility condition (Eq. 2.4) and δ_2 may be determined algebraically.

With a known δ_2 , R_2 is read from B and the sum of R_2 and R_1 is laid off as an ordinate. The pitch elongations e'_{23} and e'_{32} are found at this ordinate and R_3 is determined from δ_3 . This procedure is continued to the center of the joint.

The sum of the bolt forces, R , are compared with one-half of the gage load, $P_G/2$, and these should be equal in order to satisfy the equilibrium condition (Eq.2.1). The difference of the two represents one half of the total error in equilibrium and the original assumption for R_1 should be modified accordingly.

With a new value of R_1 , the solution is repeated until the error is within acceptable limits.

3. BEHAVIOR OF LONG BOLTED JOINTS

3.1 Theoretical and Experimental Work

A theoretical and experimental program was planned to study the effect of pitch on bolted joints. A series of hypothetical joints were designed with pitch as the only variable. These hypothetical joints were investigated by the theoretical method described in Chapter 2 and made use of the plate calibration specimens described previously. The theoretical connections were designed with the object that available experimental work could be used to validate results.

3.11 Description of Hypothetical Joints

Four hypothetical bolted joints were analyzed to obtain information about the effect of pitch. Each joint had nine bolts in line but the pitch varied from joint to joint being 2-1/2", 3-1/2", 4-1/2" and 6". Other features of the joints held constant were width, thickness, fastener size, and hole diameter.

The four hypothetical joints were designed for a tension-shear ratio, T/S, of 1:1.10. Each joint was four inches thick,

being made up of four A-7 steel plates one-inch thick and 13.78 inches wide. Plate material (plate calibration stock) had the following average properties.

Static Yield Level	28.4 ksi
Ultimate Tensile Strength	60.0 ksi
Elongation in 8 Inches	33.2%

The joints were assumed to be fastened with 7/8 inch diameter four-inch grip A325 bolts having regular semi-finished hexagon heads. The bolts would be installed in 15/16 inch diameter clearance holes drilled simultaneously through the four plies of material. The properties of the bolt lot assumed for the theoretical analysis were as follows:

Ultimate tensile strength, on stress area	120.5 ksi
Ultimate shear strength	83.2 ksi

A systematic notation, illustrated in Fig. 3.1, was used to distinguish the hypothetical joints. Consider the joint PC9d-9D. The symbol PC signifies that this is a hypothetical joint analyzed through the use of a plate calibration specimen. The 9 means that the net section of the plate calibration is for a joint having nine 7/8 inch bolts in line designed at a T/S of 1:1.10. The letter d denotes the pitch while the

9D means that the imaginary joint had nine D-Lot bolts in line.

3.12 Prototype Testing

One joint, D91, was actually fabricated and tested. This specimen was identical to the hypothetical joint PC9b-9D except that it had two lines of nine bolts each. Failure of D91 occurred when a single end bolt unbuttoned at a test load of 1358^k (avg. bolt shear stress = 62.8 ksi). It is assumed that the bolts in this connection possessed the average strength of single D-Lot bolts tested in double shear, 85.3 ksi. Detailed descriptions of this test will be found in Ref. 11.

3.2 Other Experimental Work Related to the Variation of Pitch

Ultimate strength data is available from three tests of long bolted joints whose results⁽⁸⁾ are useful in a study of the effect of pitch. These were double shear splices with two lines of 7/8 inch diameter, regular head, A325 bolts (Fig. 3.1). One specimen, D10, had ten rows of bolts while the others, D13 and D13A, had thirteen. The specimens, D10, D13A and D13 differed from D91 in that they were fabricated of eight one inch plates.

The bolts, designated the C-Lot, had an average tensile strength of 53.5 kips. Shear tests of these bolts showed an average ultimate shear strength of 91 ksi. The plate material used was from the same heat and ingot as the plate used in D91.

The joints D10 and D13 were fabricated at a pitch of 3-1/2 inches but the joint D13A had a pitch of 2-5/8 inches (equal to three times the bolt diameter), the minimum allowable under AISC specifications. With these dimensions D10 and D13A were equal in overall length, that is, center-to-center of end fasteners. This resulted in a brief set of tests which would concisely show the effect of pitch (Fig. 3.2): D10 and D13A were equal in overall length; D13A and D13 had equal numbers of pitches; while D10 and D13 would define the end points of the unbuttoning phenomena for the three tests.

The three tests resulted in the following:

JOINT	ULTIMATE LOAD	AVG. BOLT SHEAR STRESS
D10	1544 ^k	64.23 ksi
D13A	1988 ^k	63.61 ksi
D13	1854 ^k	59.33 ksi

An additional specimen, D101, was tested and complete theoretical analysis was available from previous work.⁽¹¹⁾ This joint had two lines of ten D-Lot bolts each and failed by unbuttoning a single end bolt at a test load of 1506^k (avg. bolt shear = 62.6 ksi).

4. BEHAVIOR OF LONG RIVETED JOINTS

4.1 Application of Theory

With slight modifications, the semi-graphical analysis described may also be used for riveted joints. A bolt and rivet behave in a similar manner except that the rivet is assumed to entirely fill the hole and no slip is possible. Thus, the value of c in Eq. 2.2 would be zero. Actually, the rivet in some cases does not entirely fill the hole and slip may take place.

Because the effects of slip are regarded as nonessential to ultimate strength behavior, the same equations apply to riveted joints as did bolted joints and analysis proceeds accordingly.

4.2 Theoretical and Experimental Work

The balanced design tension-shear ratio for A7 plates fastened by A141 rivets is 1/0.75. A hypothetical joint can be devised using the plate calibration specimen PC9b and thirteen 7/8 inch rivets in line that will have T/S equal to 1/0.76.

A second theoretical program was introduced to study the effect of pitch on riveted joints. Using the plate calibration work, several hypothetical joints were analyzed by theoretical means. Additional test specimens were fabricated and tested as part of the general research program. The results of theoretical and experimental work were arranged to show comparative degrees of validity.

4.21 Description of Hypothetical Joints

Five hypothetical riveted joints were analyzed to obtain information about the effect of pitch. Four joints had thirteen rivets in line and one had ten rivets in line. All were designed at T/S equal to 1/0.75. Using the plate calibration specimens described these hypothetical riveted joints were similar to the series of theoretical bolted joints.

The joints were assumed to be fastened with 7/8 inch diameter four-inch grip ASTM-A141 rivets installed in 15/16 inch diameter holes. The properties of these DR lot rivets were as follows:

Ultimate tensile strength 57.7 ksi

Ultimate shear strength 52.9 ksi

A similar notation system, illustrated in Fig. 4.1, was

used to distinguish the hypothetical joints. The specimen PC9c-13DR was analyzed using plate calibration specimen PC9c and thirteen DR-Lot rivets. Proportions of other joints conform to this notation.

Of the five hypothetical joints, PC7b-10DR, PC9c-13DR, and PC9b-13DR were analyzed completely for behavior under load. The remaining two, PC9d-13DR and PC9e-13DR were analyzed for ultimate strength only.

4.22 Prototype Testing

Two joints, DR101 and DR131, were fabricated and tested. These specimens had two lines of ten and thirteen 7/8 inch diameter A141 rivets and were similar to hypothetical joints PC7b-10DR and PC9b-13DR respectively.

Riveted shear jigs were fabricated at the same time as the joints to provide calibration specimens whose post-driven properties were the same as the fasteners in the connection. An average shearing load vs. deformation curve is shown in Fig. 4.2. The average ultimate double shear strength of these rivets was 52.9 ksi. Coupons cut from undriven rivets gave an average ultimate tensile strength of 57.7 ksi (further

details are available in Ref. 9). Failure of both joints took place when single rivets unbuttoned at the following loads:

JOINT	FAILURE LOAD	AVG. NOM. SHEAR STRESS
DR101	942 kips	39.2 ksi
DR131	1216 kips	38.9 ksi

5. THEORETICAL AND EXPERIMENTAL RESULTS

5.1 Connector Forces

5.11 Bolted Joints

The effect that pitch has on connector forces in bolted joints will be shown with the aid of Fig. 5.1 and Fig. 5.2. The abscissa is the bolt force, R , and the ordinate is the total load on the joint, P_G . Considering PC9c-9D, one can see that after the plate reaches its net section yield load, R_1 increases more rapidly. The remaining bolts continue to carry increasing loads at a rate of increase similar to that in the completely elastic phases of stress. However, as plates begin yielding farther and farther through the connection, each bolt in turn reaches a point beyond which load is added at a much faster rate.

Comparing the remaining three joints in which the pitch is increased from the 2-1/2" to 6" the same general behavior is observed although there is some difference in the behavior of those bolts at the center of the connection. In the connections having larger pitch distances, the difference in strains in the outer pitches increase very rapidly causing the end bolts to pick up load faster. Thus, the load carried

by the inner bolts reaches a maximum and then begins to fall off as is shown in Figs. 5.1 and 5.2.

5.12 Riveted Joints

Figure 5.3 is a comparison of two riveted joints that are similar in overall length but which have different numbers of fasteners. The joint PC7b-10DR, with ten rivets at a 3-1/2" pitch, has an overall length of 31.5" compared to 30.0" for the joint PC9c-13DR which has 13 rivets at a 2-1/2" pitch. In contrast, Fig. 5.4 shows the rivet forces in a third joint, PC9b-13DR, which has 13 rivets at a 3-1/2" pitch.

Figures 5.3 and 5.4 demonstrate the disparity of rivet loads within a connection. The distribution is similar to that seen in bolted joints but one outstanding difference is evident. The end rivet reaches a maximum load and then falls off; whereas in a bolted joint the end fastener reaches a maximum load and ruptures almost immediately. Because the end rivet unloads in this manner, there is a sharp change in curvature of the load lines near ultimate for the other rivets in the joint. This results when the remaining fasteners must assume the additional load thrown off by the end rivet.

The reason for the difference of the bolted and riveted joints is apparent from the shear calibration curves of the individual fasteners (Fig. 4.2). These are average curves and the rivet is shown to fracture at a calibration offset of about 0.31". This deformation is reached after the rivet passes its ultimate strength and begins to unload. Actually, the fracture deformation varies somewhat from rivet to rivet and is significantly affected by the rate of loading. Deforming the rivet slowly enough, it is possible to cause fracture at loads as low as five kips or less. This behavior makes ultimate strength predictions more difficult for riveted joints.

The bolt is more sensitive to rate of deformation and the deformations associated with ultimate and rupture loads are almost equal. At the loading rates used in tests of large prototype specimens the end bolt would rupture very close to its ultimate strength so the theoretical analysis used the calibration curve shown in Fig. 4.2.

5.2 Ultimate Strength and Unbuttoning Factor

It is convenient to non-dimensionalize the ultimate strength of a connection in terms of the strength of a single

fastener. That is, the average nominal shear stress at failure, τ_{avg} , is divided by the shear strength of a single fastener, τ_1 , to produce the unbuttoning factor, U.

$$U = \frac{\tau_{avg}}{\tau_1}$$

This unbuttoning factor may also be thought of as a measure of the connection's efficiency or ability to develop the potential strength of its fasteners. The ultimate strengths and unbuttoning factors for all joints are summarized in Table 5.1.

In a connection with a given number of fasteners, the ultimate strength will decrease as the pitch is increased. The ultimate strength of PC9c-9D is 720 kips while that of PC9e-9D is 620.0 kips. This is a reduction of 13.9% caused by increasing the pitch from 2-1/2" to 6". The excellent correlation between predicted ultimate strength and actual failure load for D91 (PC9b-9D) gives some indication of the validity of the theoretical analysis. (11)

The thirteen fastener riveted connections with pitches of 2-1/2, 3-1/2, 4-1/2, 6" (Table 5.1) show variations of ultimate loads similar to those in bolted connections. For

these joints there is a 13.8% reduction in strength due to an increase in pitch from 2-1/2" to 6".

Figure 5.5 compares the general behavior of a nine-fastener bolted joint and a thirteen fastener riveted joint where pitch is variable. The abscissa is the pitch and the ordinate the unbuttoning factor. It is apparent from this figure that the general effect of pitch is similar in nature in riveted and bolted connections.

Comparing PC9c-13DR, PC7b-10DR, and PC9b-13DR, it is possible to gain further insight into the effect of pitch on joint efficiency as expressed by unbuttoning. The unbuttoning factors of the three joints were 0.775, 0.761, and 0.724, respectively. These seem to indicate that length is the most significant single factor in unbuttoning. On the other hand, had the number of pitches been the controlling parameter, one would expect PC9c-13DR to be equal to PC9b-13DR which was not the case.

The tests of D10, D13A and D13 resulted in unbuttoning factors of 0.708, 0.701 and 0.654, respectively. The two joints of equal length, D10 and D13A, had similar unbuttoning factors with the higher number of pitches causing a rather

slight reduction in efficiency. Where either length or pitch is significantly different, comparison shows a wide variance in unbuttoning behavior.

Noting the many possible combinations of results, one can make the following generalization. The ultimate strength of a joint is not determined by the number of pitches alone. It does, however, depend upon the product of the pitch distance and total number of pitches, which two factors combined make up the total length of the joint.

It is also of interest to compare the ultimate strengths of riveted and bolted joints. With a given working load, a riveted joint designed at $T/S = 1/0.75$ should equal the ultimate strength of a bolted joint whose $T/S = 1/1.10$. However, comparison of the nine-fastener bolted joints with the thirteen fastener riveted joints demonstrates that the bolted joints are stronger (Table 5.1). The bolted joints require 33% less fasteners and consequently the riveted joints are much longer. This results in lower efficiencies and ultimate strengths.

5.3 Bolt Deformation

The effect of pitch on bolt deformation is summarized in

Fig. 5.6. This graph compares deformations of the end bolt in a nine-fastener bolted joint for pitches of 2-1/2", 3-1/2", 4-1/2" and 6". The relation of deformation to total gage load shows that for a given load, the amount of deformation in the end bolts increases directly with an increase in the pitch of the fasteners. Similar curves could be drawn for other bolts in the connection.

5.4 Distribution of Connector Forces

Figures 5.7 and 5.8 demonstrate the effect of pitch on bolt force distribution. Since the plots are non-dimensionalized, they eliminate differences in ultimate loads. In these graphs the abscissa represents the bolt force as a percentage of the equally distributed bolt force. If all bolts carried the same load all of the curves would be vertical lines at the abscissa 100. The ordinate represents the applied load as a percentage of the maximum gage load.

In the joint PC9c-9D (2-1/2" pitch) there is a definite trend above 90% maximum gage load whereby the initial disparity of bolt forces tends to be reduced. However, in the joint PC9b-9D (3-1/2" pitch) the trend is not

as noticeable and becomes progressively less with the other two joints at increasing pitches. Also, there is a much larger spread in the distribution of force as the pitch is increased.

Similar effects are noted in riveted joints by comparing the diagrams for PC9c-13DR and PC9b-13DR (Figs. 5.9 and 5.10). Here is noticed a similarity in pattern but a variation in degree of disparity as the pitch is increased. Comparing the results of PC7b-10DR with these joints a different pattern is observed and one thing is outstanding; the magnitude of distribution is approximately equal for the two joints of equal pitch but decidedly different for the joint with the different pitch dimension. One would, of course, expect a more uniform distribution in shorter joints and this has been shown.⁽¹¹⁾ However, it is apparent from the three riveted joints mentioned that pitch has a greater effect on the uniformity of load distribution than total number of pitches alone.

5.5 Comparison of Ductility

The data presented herein can be used to compare the relative effectiveness of the bolt and rivet for evenly

distributing load throughout a joint. The contribution of a fastener in load distribution depends upon its ductile behavior properties under shearing load. Figure 5.11 is a graphical comparison of a bolted and a riveted connection in which the abscissa represents the connector force as a percentage of the equally distributed force and the ordinates represent the gage load. The two joints being compared have equal numbers of fasteners at identical pitch distances. Both joints are proportioned for balanced design with tension-shear ratios of 1:0.75 (riveted joint) and 1:1.10 (bolted joint).

The distribution of force in the riveted joint is only slightly improved over that in the bolted joint. However, near ultimate load the actual distributions are almost identical. Most important is the concept that for equal length riveted and bolted connections, the riveted joint may be about 5% to 10% more efficient (measured by unbuttoning) but the bolted joint will be 50% stronger.

6. SUMMARY AND CONCLUSIONS

This thesis has made use of certain theoretical methods in a study of the effect of pitch on the behavior of the long joint. The theoretical solution was used to investigate ten hypothetical joints. Duplicates of four of these were actually fabricated and tested. Comparisons were also provided with three related tests of large joints. The attention was entirely on long joints and the subject matter encompasses both riveted and bolted structural connections.

Specific results were as follows:

(1) A connection's efficiency, as measured by its ability to develop the full strength of all the fasteners, is affected by changes in pitch. For a given number of fasteners, the ultimate strength of the connection will decrease as the pitch is increased. In a nine bolt joint a change in pitch from 2-1/2" to 6" resulted in a drop in ultimate strength of 13.9% (Fig. 5.1 and Fig. 5.2). Thus, the ultimate strength of the fasteners in a connection depends not only on the number of fasteners but also on their spacing in the line of the load.

(2) It has not been possible to separate pitch distance and the total number of pitches as determinants of connection efficiency (measured by unbuttoning).

(3) For a given load, the deformation of the end fasteners in a connection having a fixed number of fasteners will increase as pitch distance is increased (Fig. 5.6).

(4) Neither bolted nor riveted joints completely equalize load among the fasteners (Fig. 5.11). This behavior, indicated by reduced shear strengths in long joints, is a significant problem that should not be ignored. Though limitations on maximum pitch would have the best results, a limitation on maximum overall length is also necessary to prevent an extreme reduction of safety factor.

(5) The ductility of the high strength bolt is favorable in comparison to the structural rivet. With riveted and bolted connections of equal length and number of fasteners, the riveted joint may be about 5% or 10% more efficient (measured by unbuttoning) but the bolted

joint will be 50% stronger (Fig. 5.11).

(6) Riveted and bolted connections with similar pitch dimensions and designed for equal strength under current codes will not carry equal loads. The riveted joint requires 50% more fasteners and is necessarily much longer. This results in lower efficiency and reduced ultimate strength so the bolted joint is actually stronger.

(7) The theoretical study and conclusions therefrom have been verified by a concise test series. Three bolted joints were fabricated to study the effect of fastener pitch and demonstrated that decreasing pitch results in an increased joint efficiency.

Capital Letters

B	Bolt or bolt calibration curve
F	Force
L	Lap plate calibration curve
M	Main plate calibration curve
N	Number of pitches
P_G	Load on gage strip
P_J	Load on joint
P_{yn}	Load that causes yielding of net section
Q_{kj}	Force in lap plates between Rows j and k
R_j	Force transmitted by Bolt j
S	Average shear stress (in T/S ratio)
T	Tensile stress on net section (in T/S ratio)
U	Unbuttoning factor

Small Letters

c	Hole clearance
d_B	Bolt diameter
d_H	Hole diameter
e_{jk}	Elongation of one pitch length of plate from the centerline of Hole j to the centerline of Hole k*

- e'_{jk} Elongation of one pitch length of plate from the bearing side of Hole j to the bearing side of Hole k^*
- g Gage
- m Next to the last bolt or hole
- n Number of bolts in line or last bolt or hole
- p Pitch
- t Thickness

Greek Letters

- δ Calibration bolt offset
- λ Elongation of the radius of a hole due to plate tension
- Δ Hole offset
- Σ Summation
- τ Nominal fastener shear stress

*Normal order of subscripts indicates main plate elongations; inverted order indicates lap plate elongations.

8. TABLES AND FIGURES

HYPOTHETICAL JOINT	NUMBER OF FASTENERS n	PITCH p in.	OVERALL LENGTH L in.	THEORETICAL ULTIMATE (P _G) kips	UNBUTTONING FACTOR U	TEST SPECIMEN	TEST ULTIMATE (P _G) kips	UNBUTTONING FACTOR U
PC9c-9D	9	2 1/2	20.0	720	0.800			
PC9b-9D	9	3 1/2	28.0	680	0.756	D91	679	0.736
PC9d-9D	9	4 1/2	36.0	648	0.720			
PC9e-9D	9	6	48.0	620	0.689			
PC10b-10D	10	3 1/2	31.5	750	0.750	D101	753	0.734
	10	3 1/2	31.5			D10	772	0.708
	13	2 5/8	31.5			D13A	994	0.701
	13	3 1/2	42.0			D13	927	0.654
PC7b-10DR	10	3 1/2	31.5	483	0.761	DR101	471	0.741
PC9c-13DR	13	2 1/2	30.0	640	0.775			
PC9b-13DR	13	3 1/2	42.0	598	0.724	DR131	608	0.737
PC9d-13DR	13	4 1/2	54.0	573	0.694			
PC9e-13DR	13	6	66.0	552	0.669			

TABLE 5.1 SUMMARY OF RESULTS

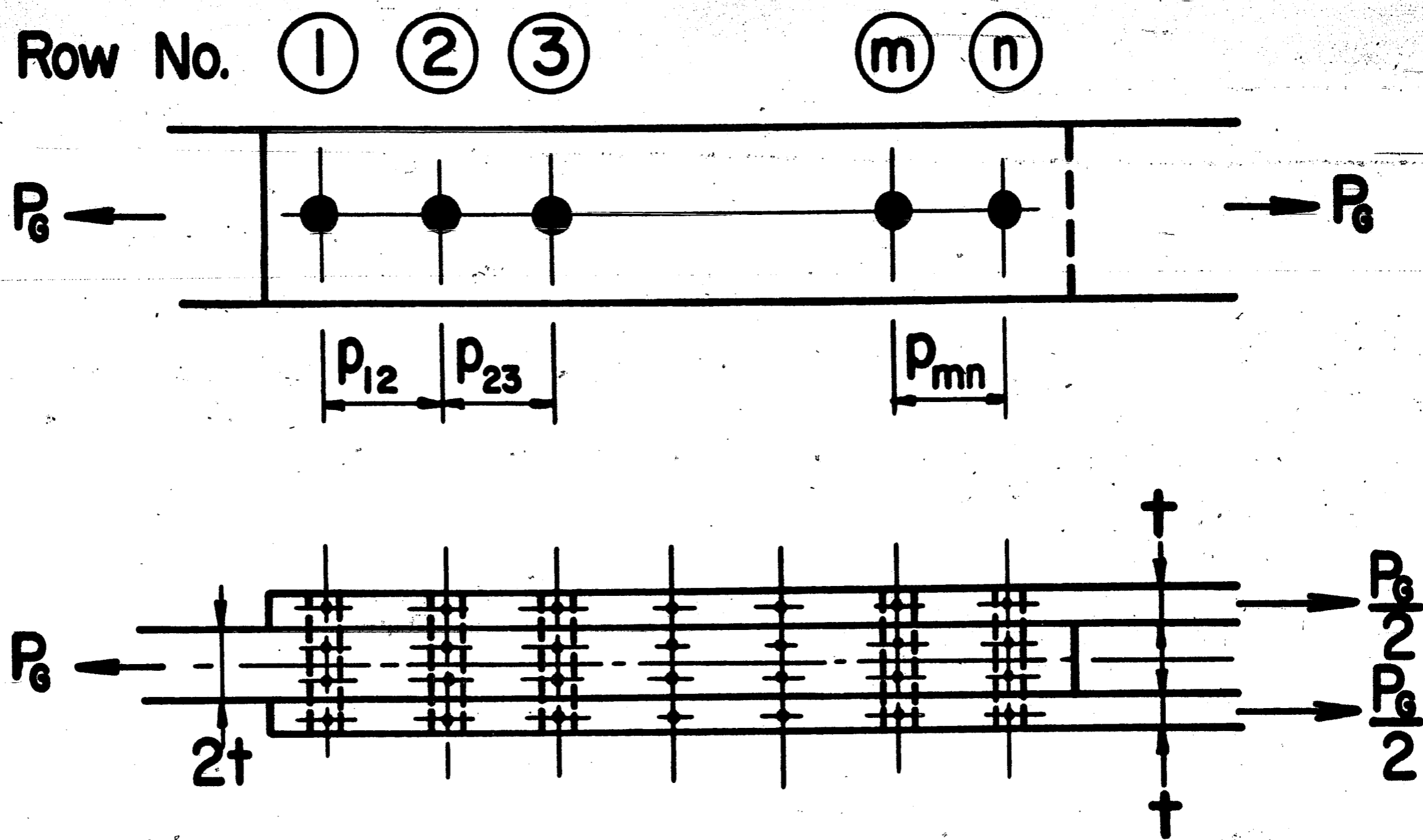

FIG. 2.1 GEOMETRY OF JOINT

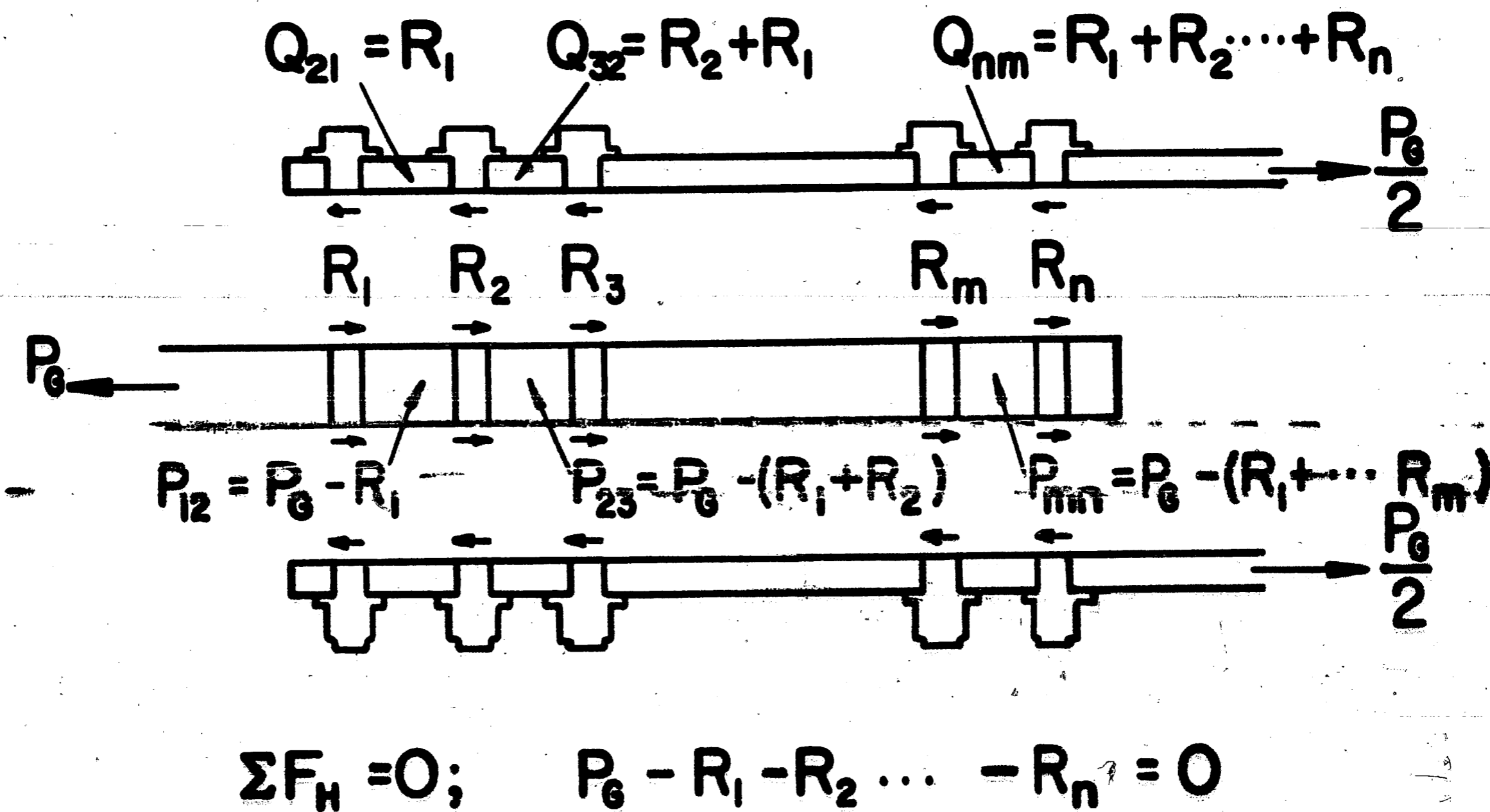

FIG. 2.2 EQUILIBRIUM CONDITION

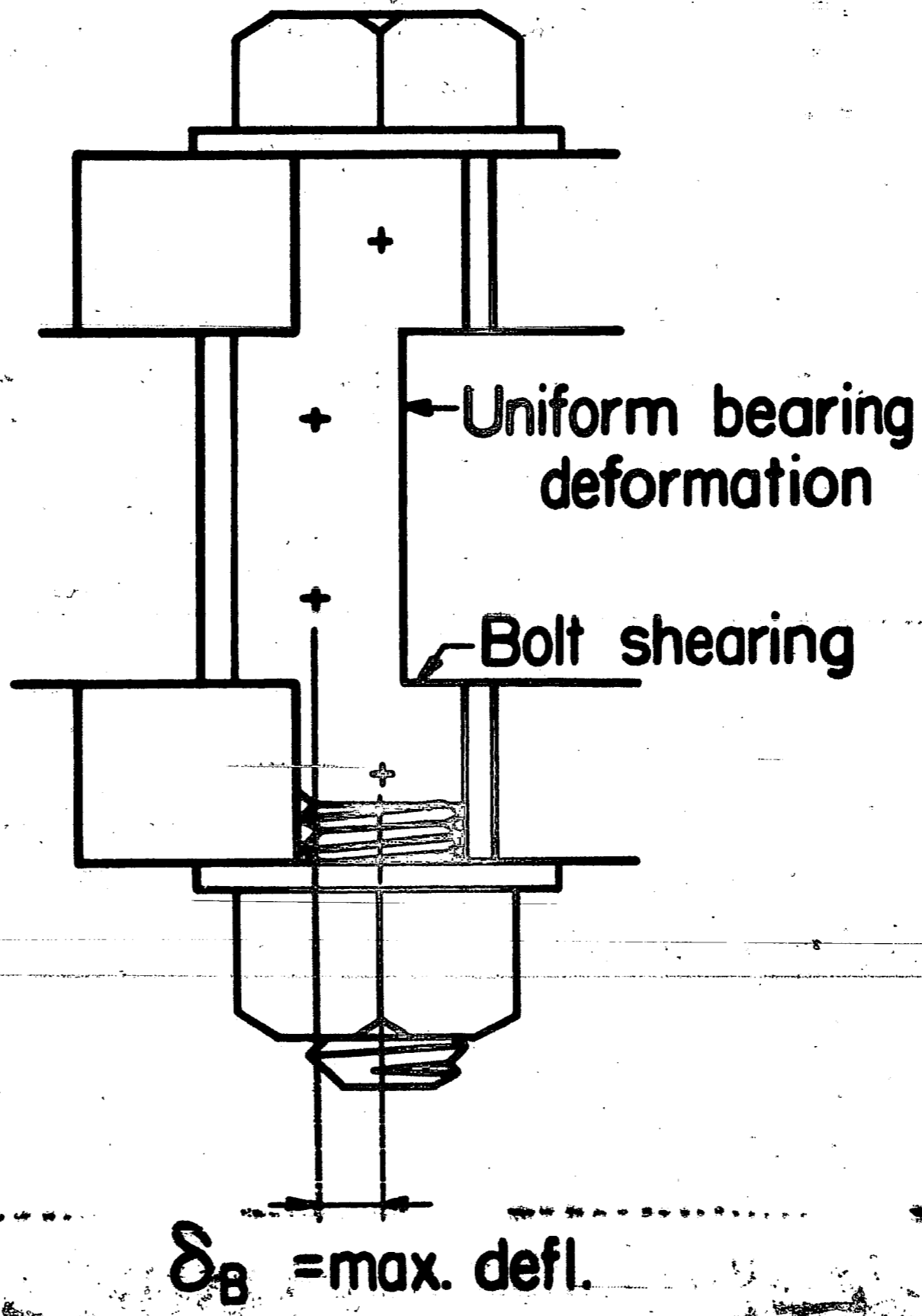

FIG. 2.3 IDEALIZED BOLT DEFORMATION

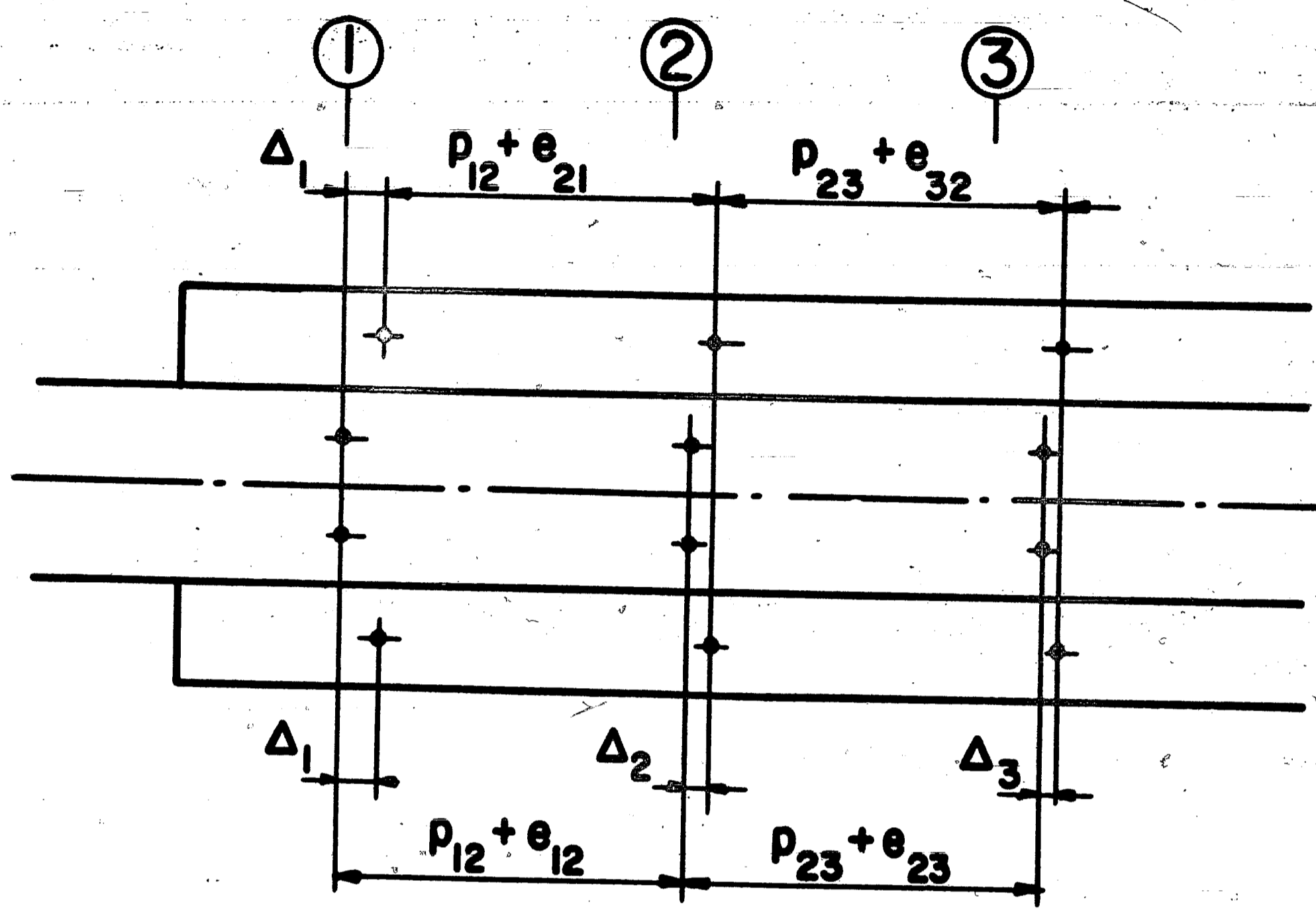

FIG. 2.4 COMPATIBILITY CONDITION

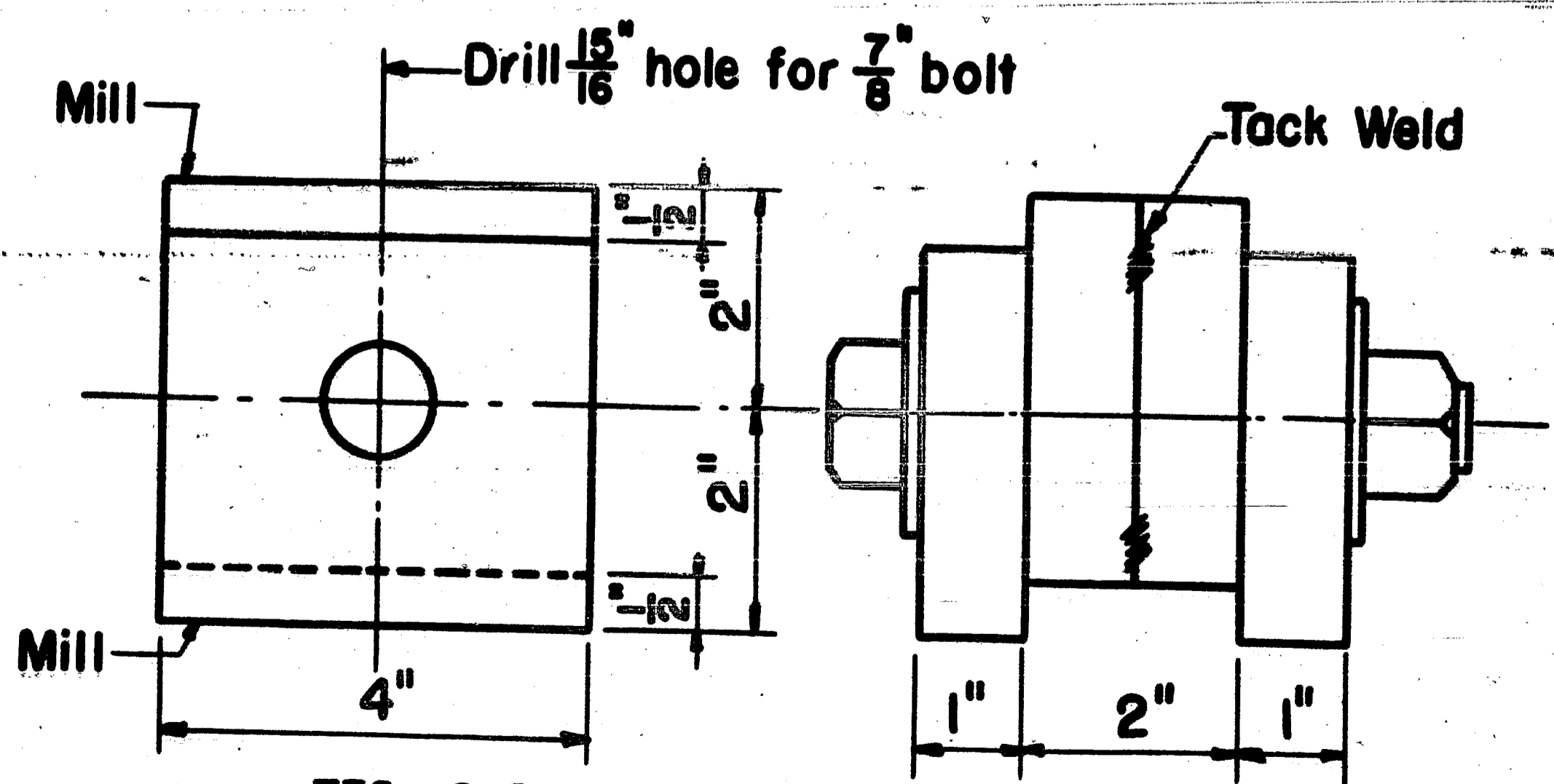

FIG. 2.5 COMPRESSION SHEAR JIG

P_B , Load on Shear Jig, kips

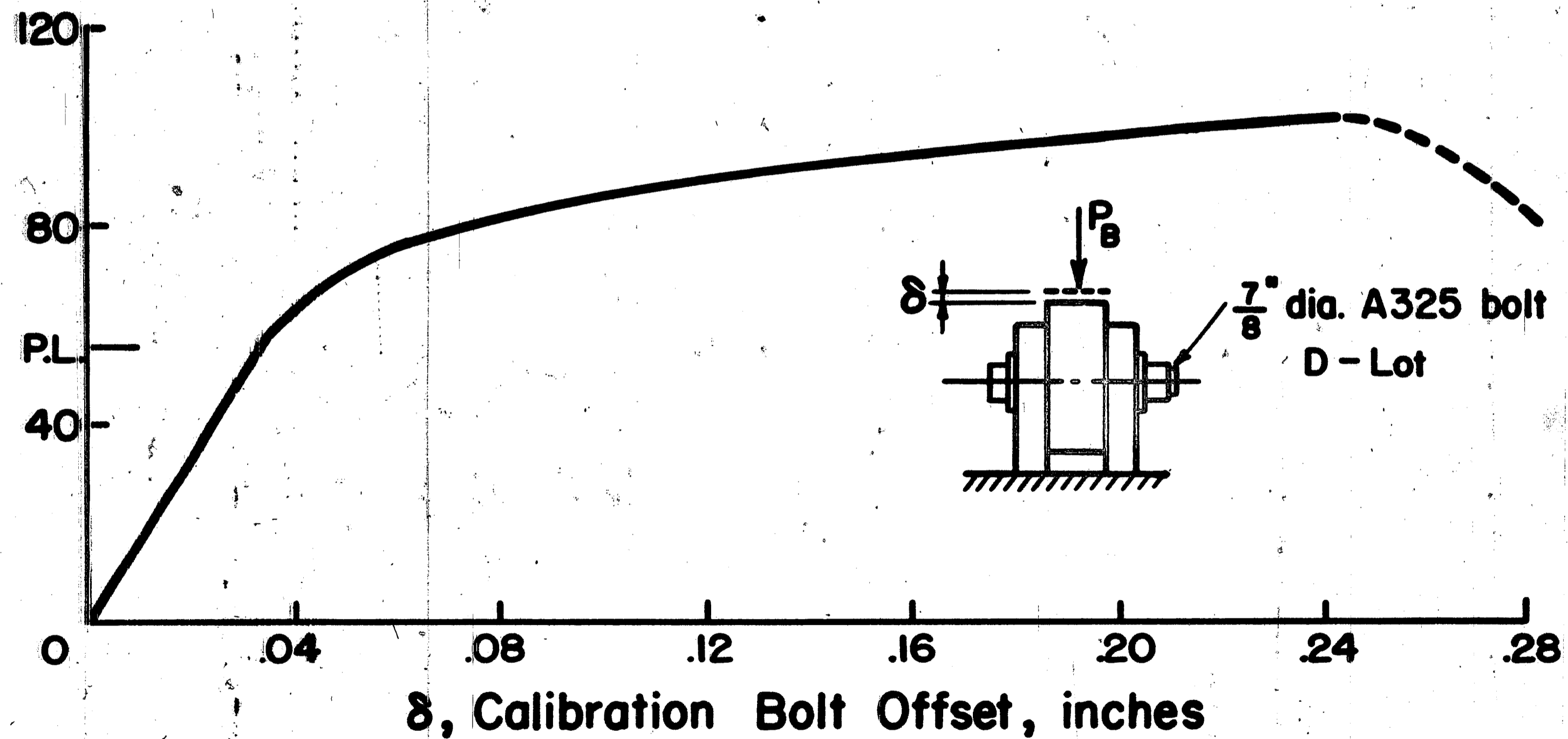
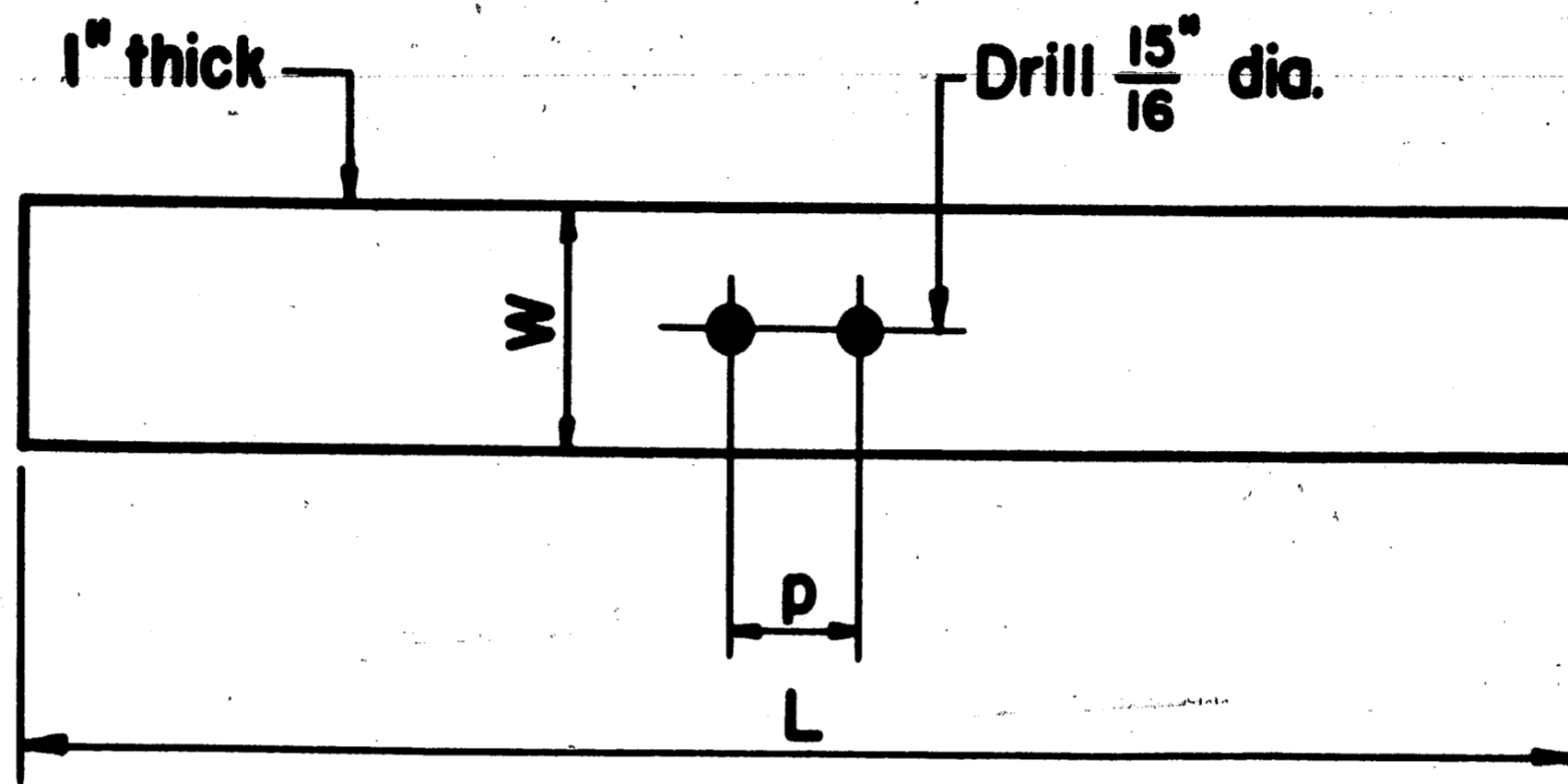

FIG. 2.6 AVERAGE BOLT SHEAR CALIBRATION CURVE



Mark	p, in.	L, in.	W, in.
PC9-c	2.50	43.5	6.88
PC9-b	3.50	46.0	6.88
PC9-d	4.50	45.5	6.88
PC9-e	6.00	47.0	6.88

PC7-b	3.50	46.0	5.56
PC10-b	3.50	46.0	7.54

FIG. 2.7 DIMENSIONS OF PLATE CALIBRATION SPECIMENS

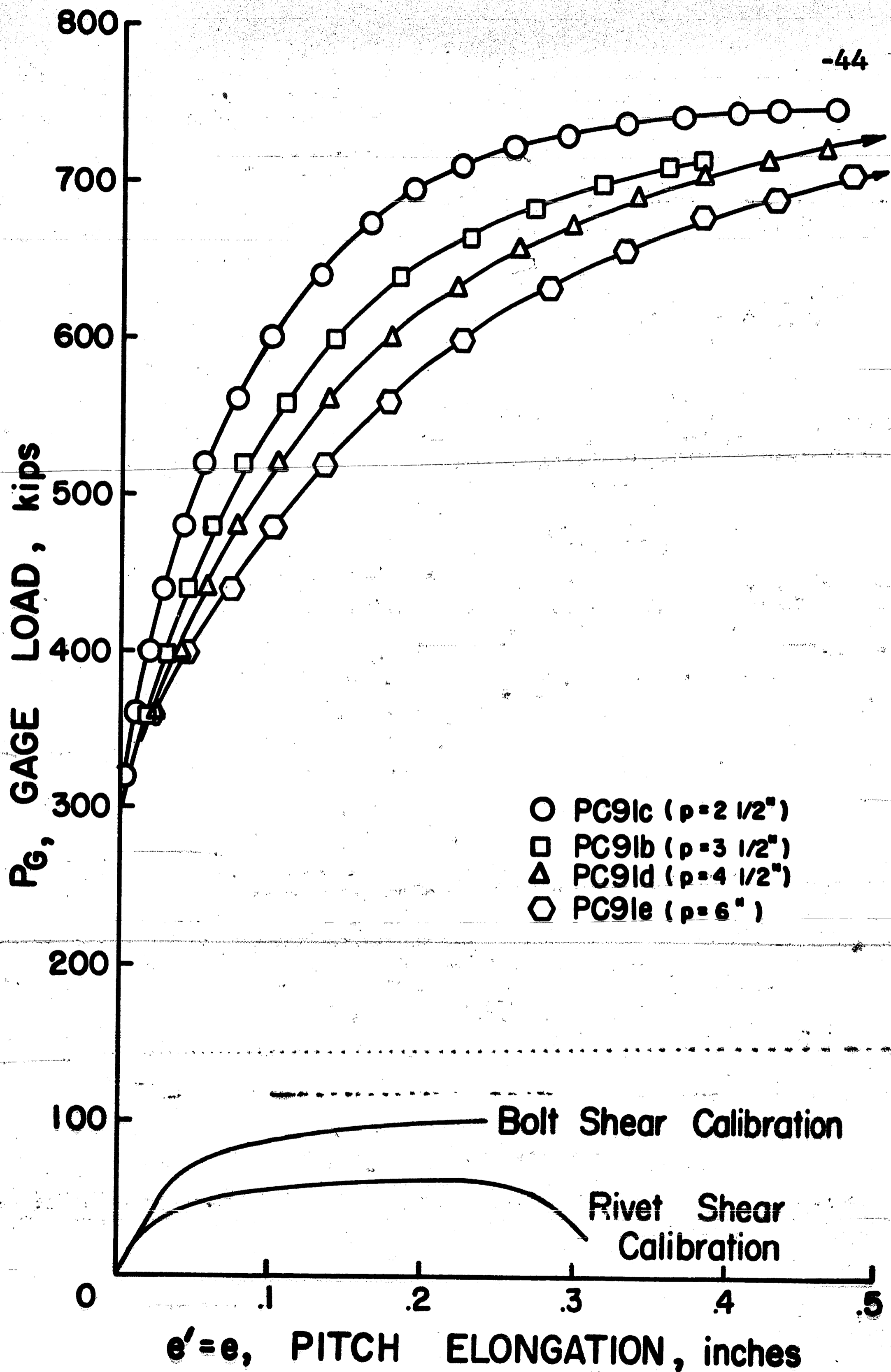

FIG. 2.8 CALIBRATION RESULTS

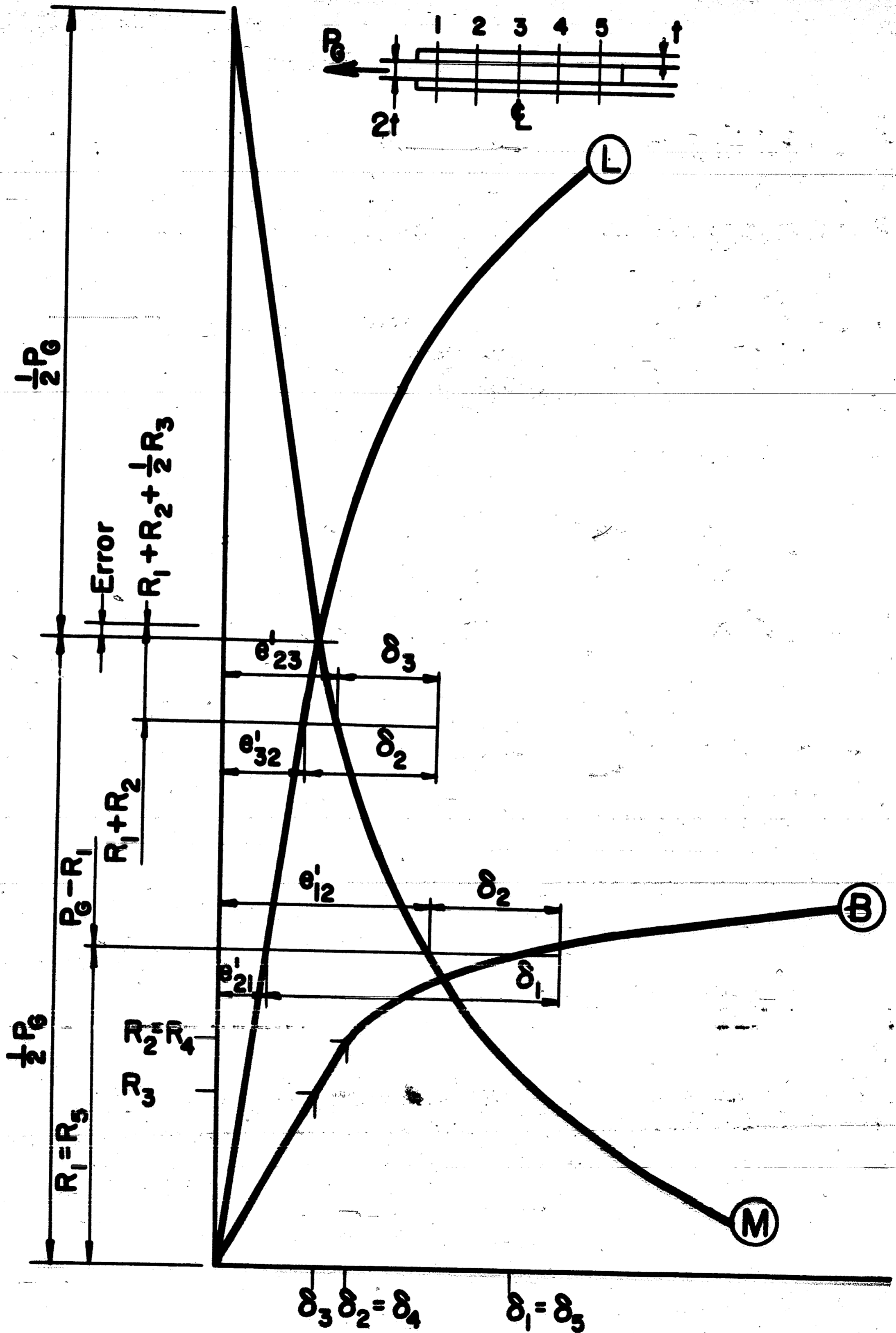
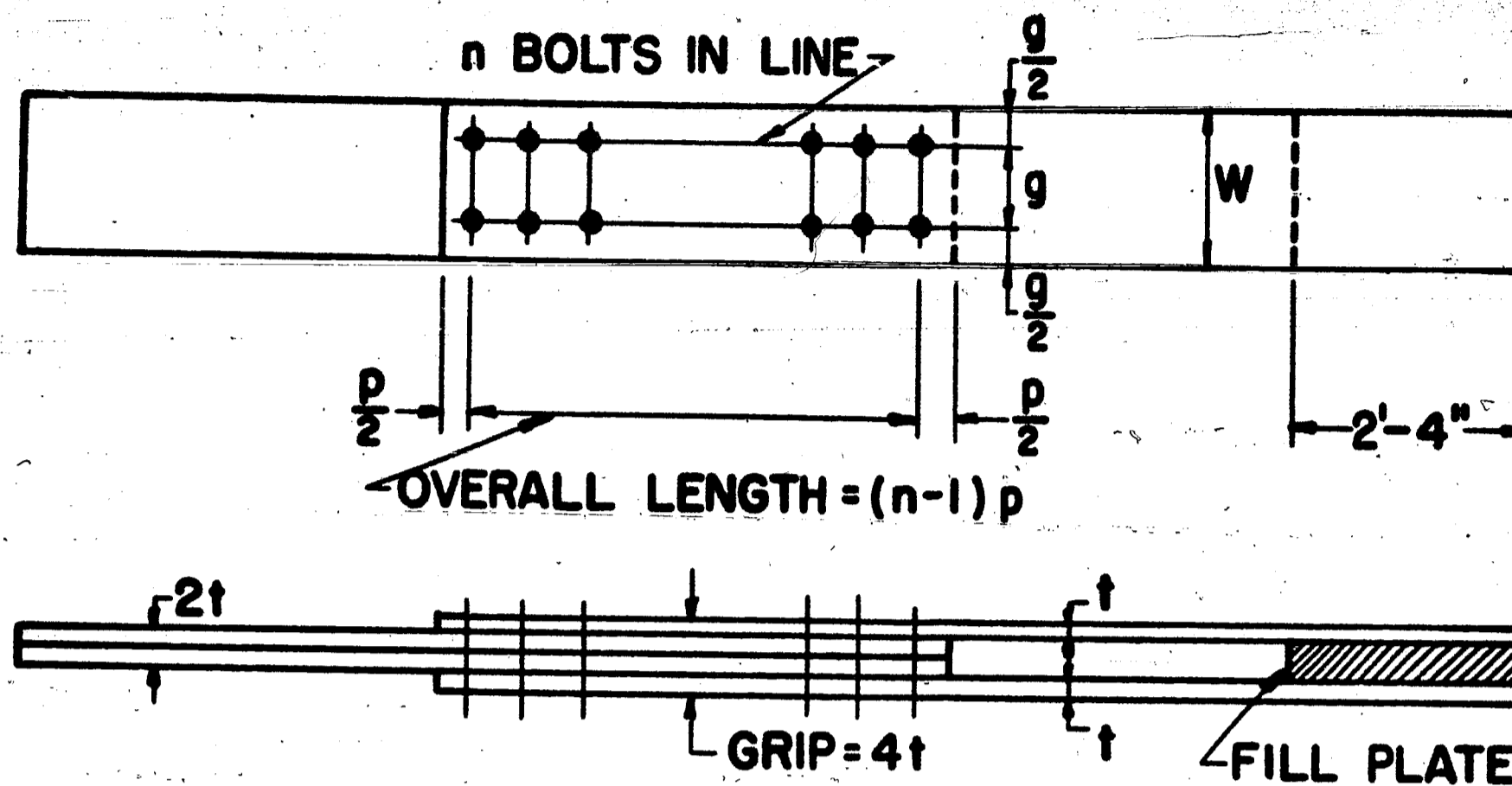

FIG. 2.9 SOLUTION OF EQUATIONS



Note:
 Test Specimens all have two lines of bolts whereas hypothetical joints have only one.

HYPOTHETICAL JOINT		DIMENSIONS					TEST SPECIMEN	
MARK	PLATE WIDTH	THICKNESS 2t	PITCH p	NO. of 7/8" A325 BOLTS	OVERALL LENGTH	T/S	MARK	
PC 9c-9D	13.78	2"	2 1/2"	9	20"	1/1.10	—	
PC 9b-9D	13.78	2"	3 1/2"	9	28"	1/1.10	D91	
PC 9d-9D	13.78	2"	4 1/2"	9	36"	1/1.10	—	
PC 9e-9D	13.78	2"	6"	9	48"	1/1.10	—	
PC 10b-10D	15.10	2"	3 1/2"	10	31.5"	1/1.10	D101	
—	8.47"	4"	3 1/2"	10	31.5"	1/1.10	D10	
—	10.47"	4"	2 5/8"	13	31.5"	1/1.10	D13A	
—	10.47"	4"	3 1/2"	13	42.0"	1/1.10	D13	

FIG. 3.1 SUMMARY OF HYPOTHETICAL BOLTED JOINTS AND RELATED TEST SPECIMENS

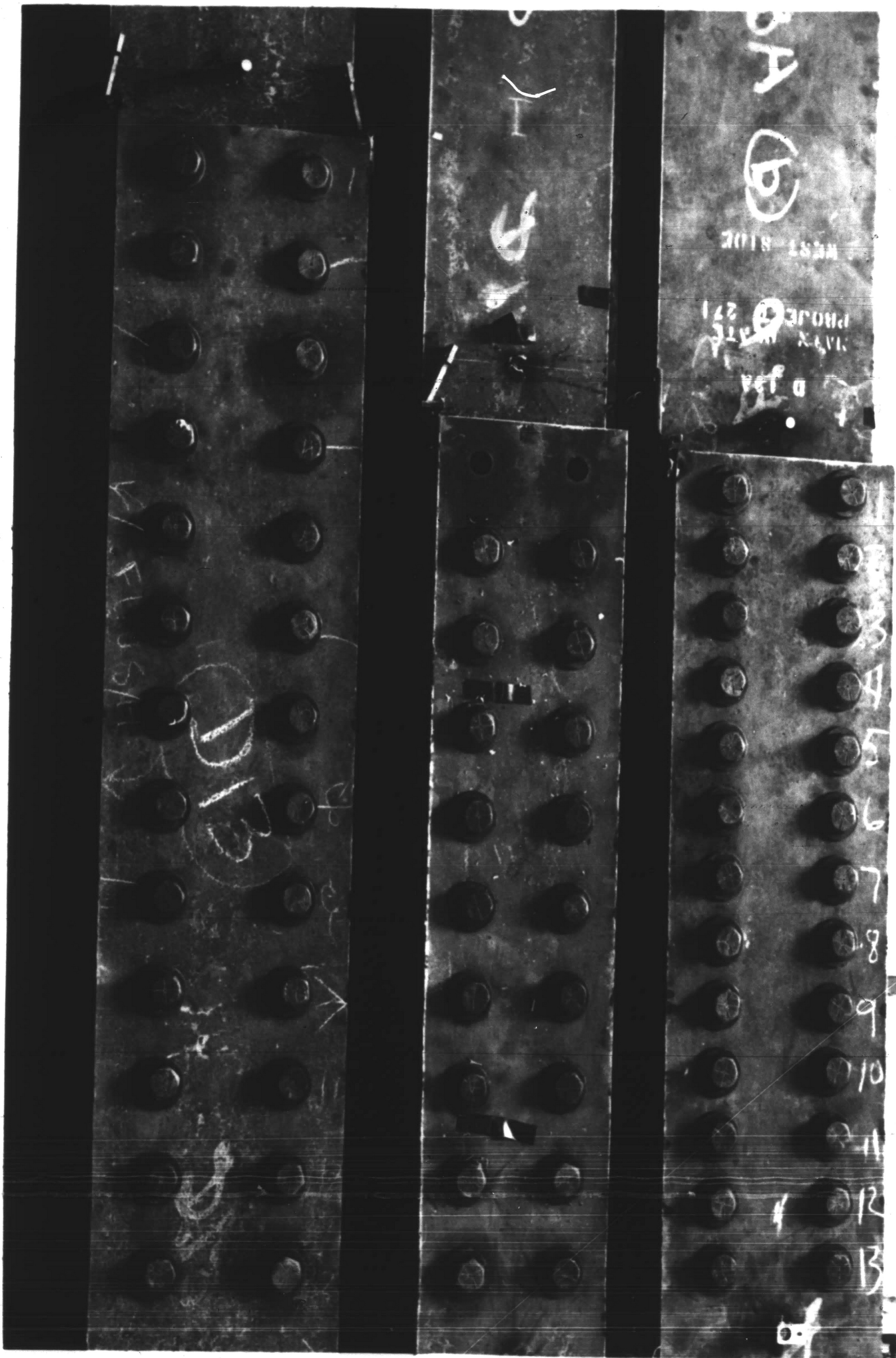

DI3

DIO

DI3A

FIG. 3.2 RELATED TEST SPECIMENS

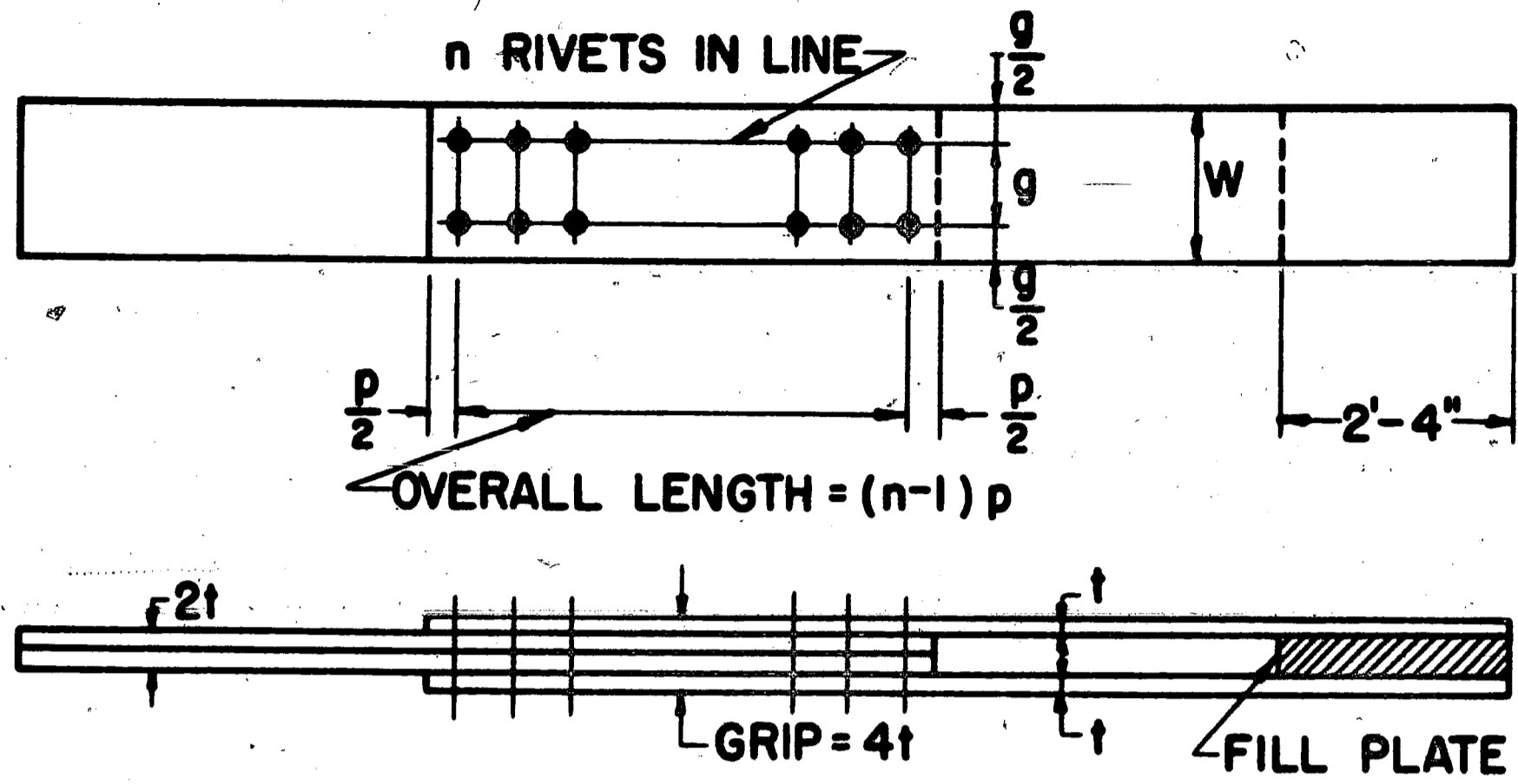

Note:

Test Specimens all have two lines of rivets whereas hypothetical joints have only one.

HYPOTHETICAL JOINT		DIMENSIONS					TEST SPECIMEN	
MARK	PLATE WIDTH	THICKNESS 2t	PITCH p	NO. of 7/8" A141 RIVETS	OVERALL LENGTH	T/S	MARK	
PC7 b-10DR	11.12	2"	3 1/2"	10	31 1/2"	1/0.77	DR101	
PC9 c-13DR	13.78	2"	2 1/2"	13	30"	1/0.76	—	
PC9 b-13DR	13.78	2"	3 1/2"	13	42"	1/0.76	DR131	
PC9 d-13DR	13.78	2"	4 1/2"	13	54"	1/0.76	—	
PC9 e-13DR	13.78	2"	6"	13	72"	1/0.76	—	

FIG. 4.1 SUMMARY OF HYPOTHETICAL RIVETED JOINTS AND RELATED TEST SPECIMENS

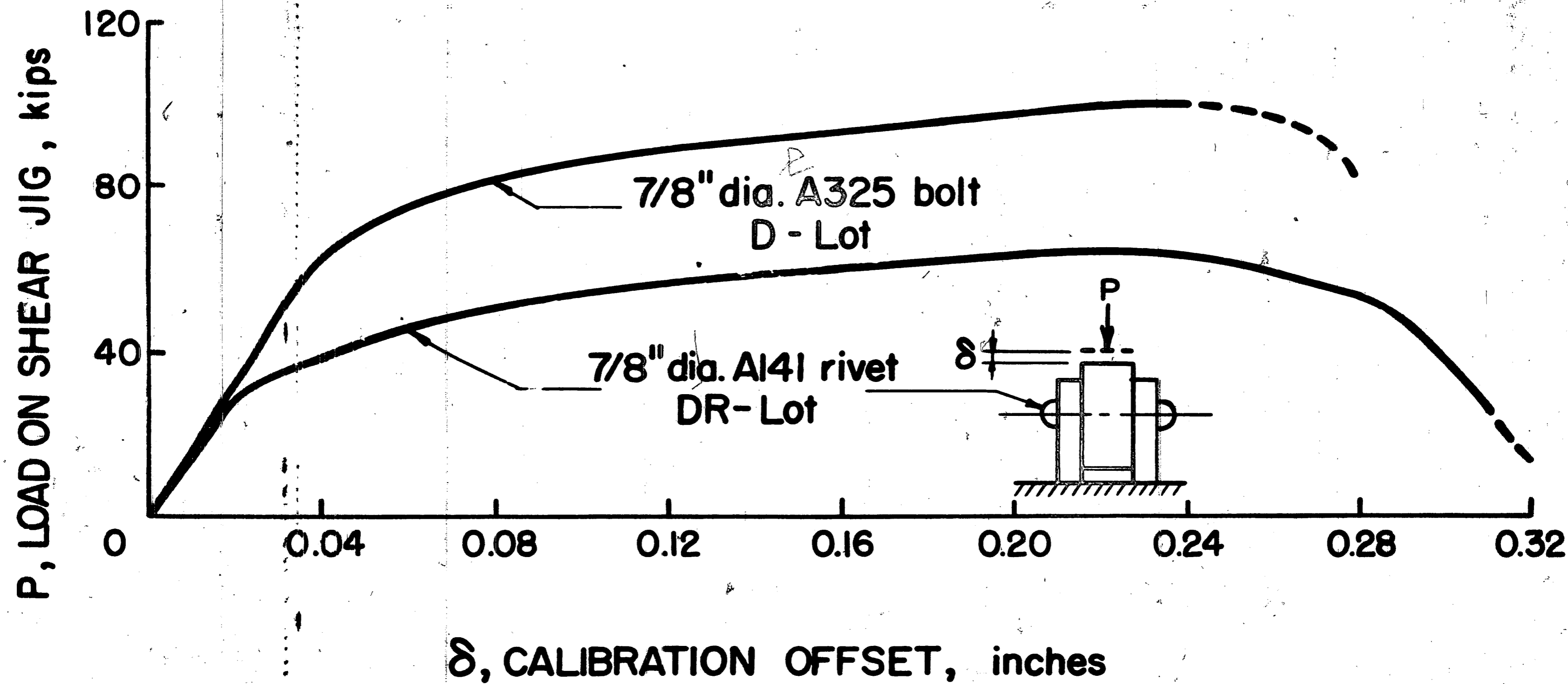

FIG. 4.2 AVERAGE RIVET SHEAR CALIBRATION CURVE

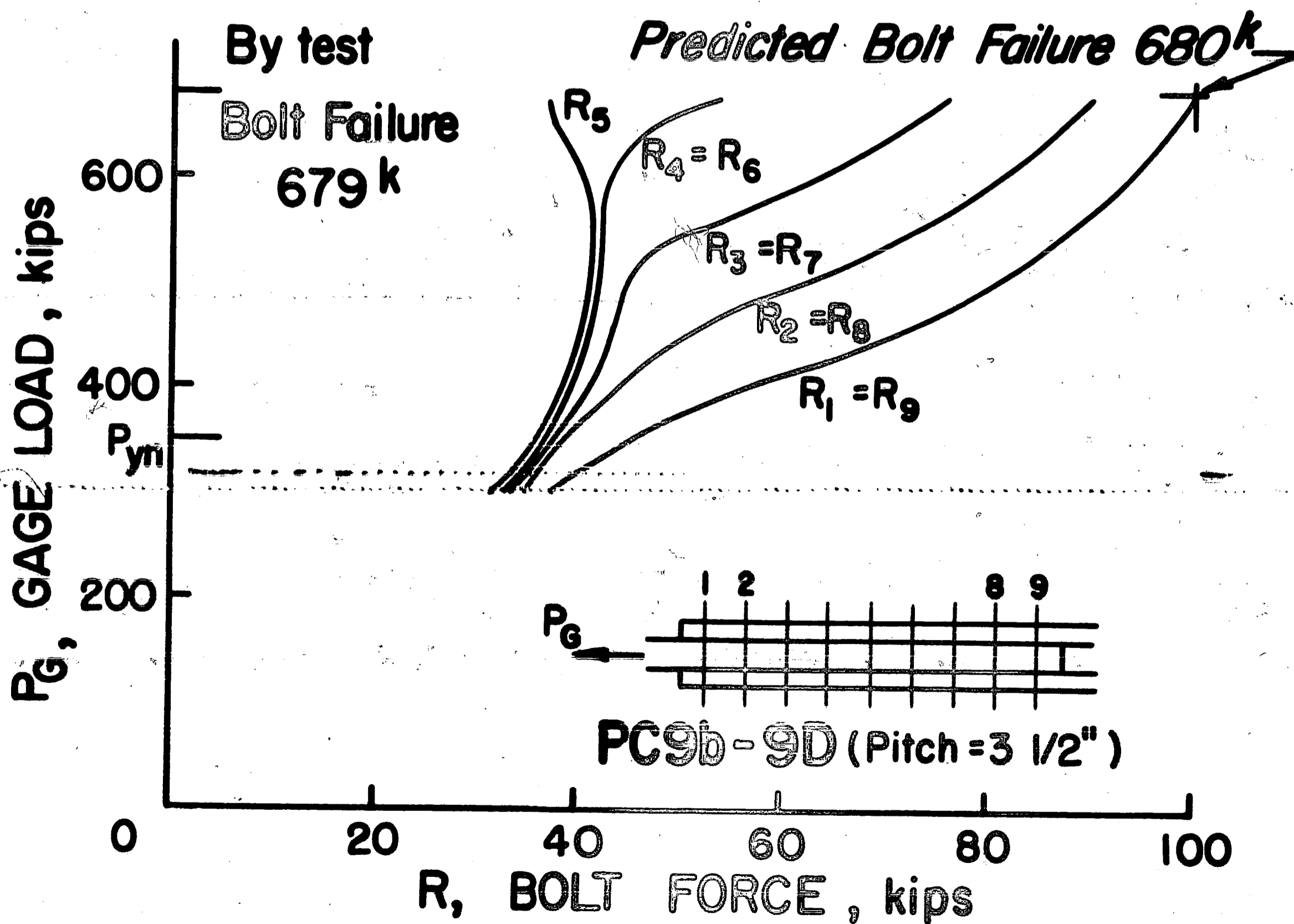
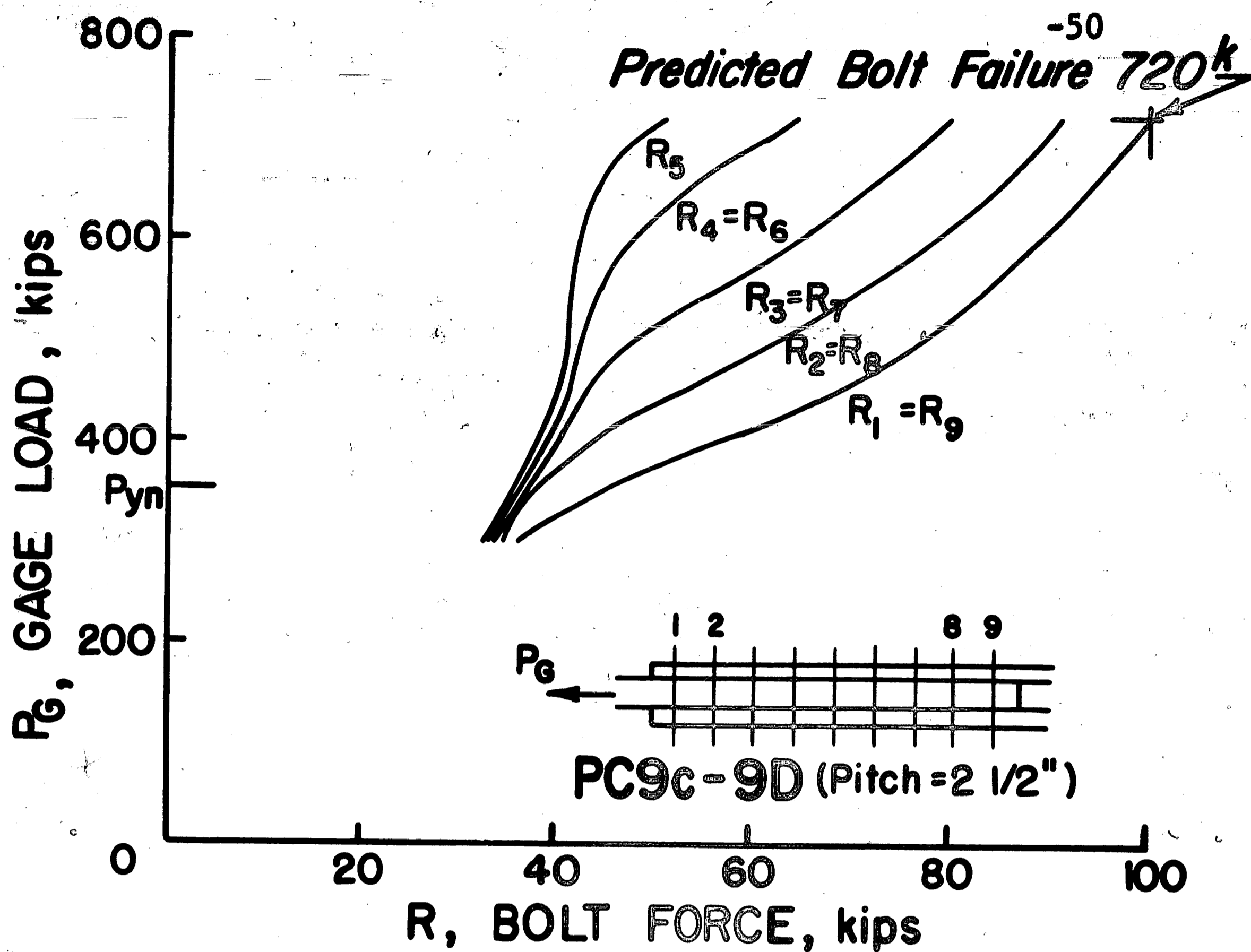

FIG. 5.1 JOINTS PG9c-9D AND PG9b-9D, THEORETICAL BOLT FORCES

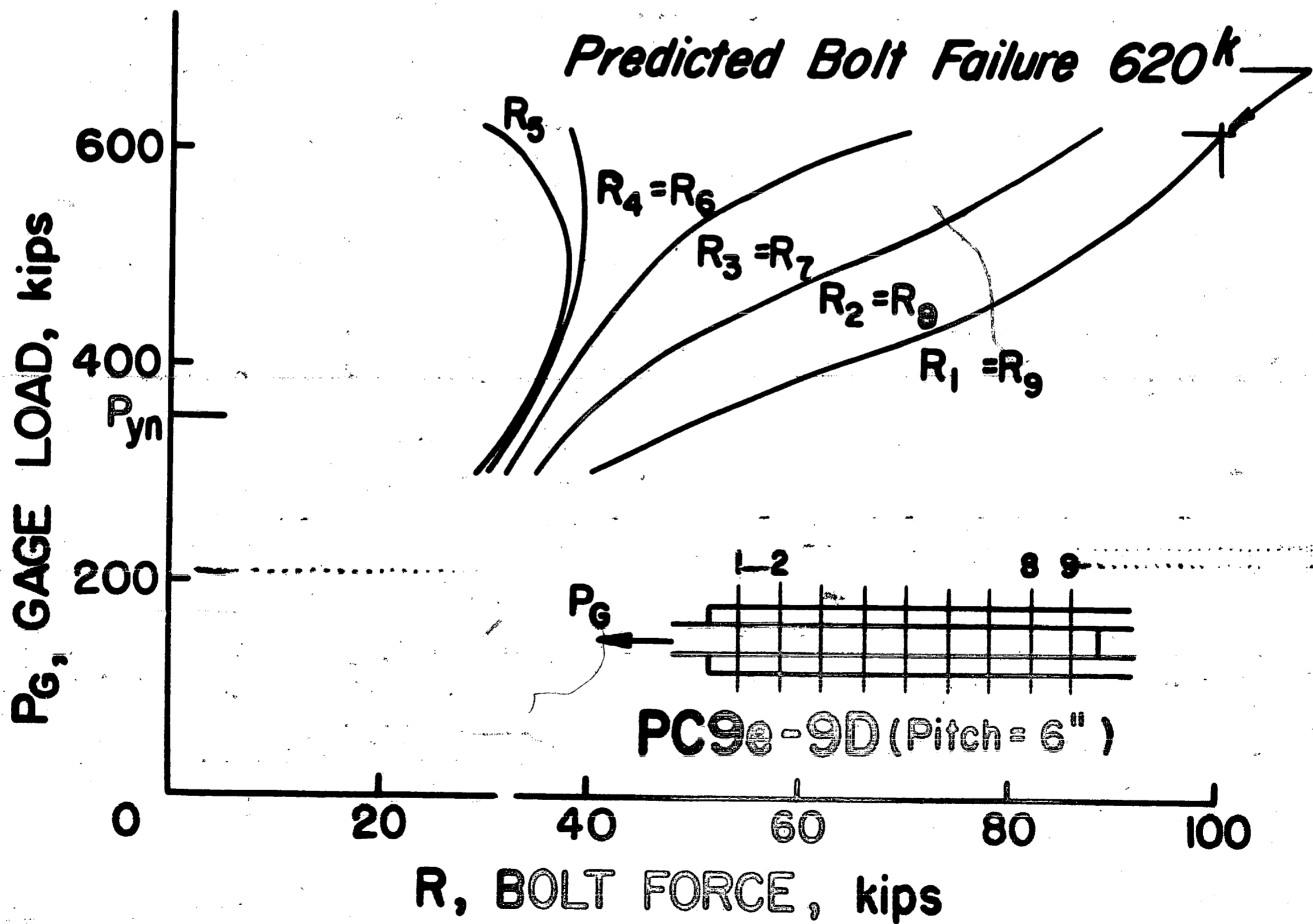
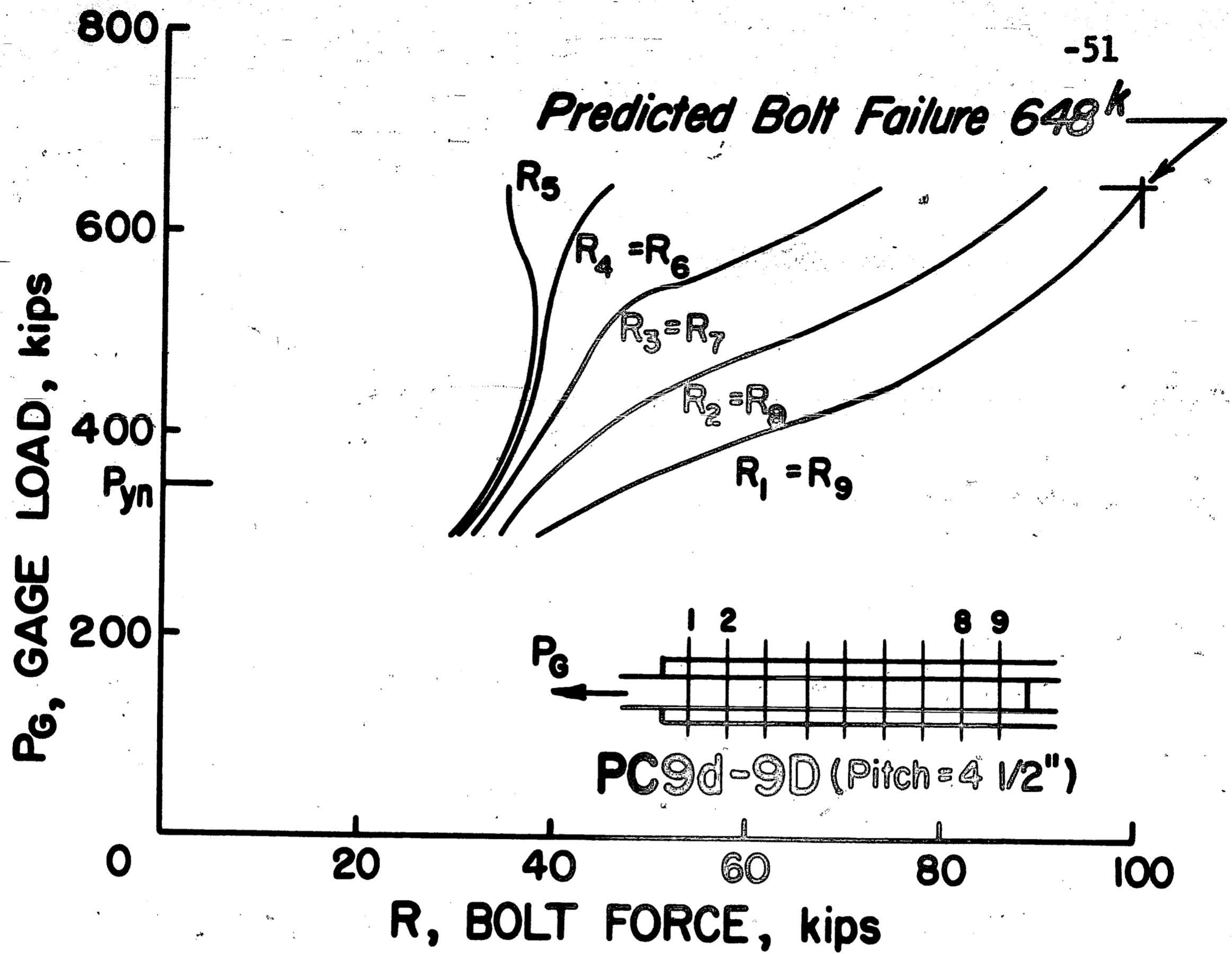

FIG. 5.2 JOINTS PC9d-9D AND PC9e-9D, THEORETICAL BOLT FORCES

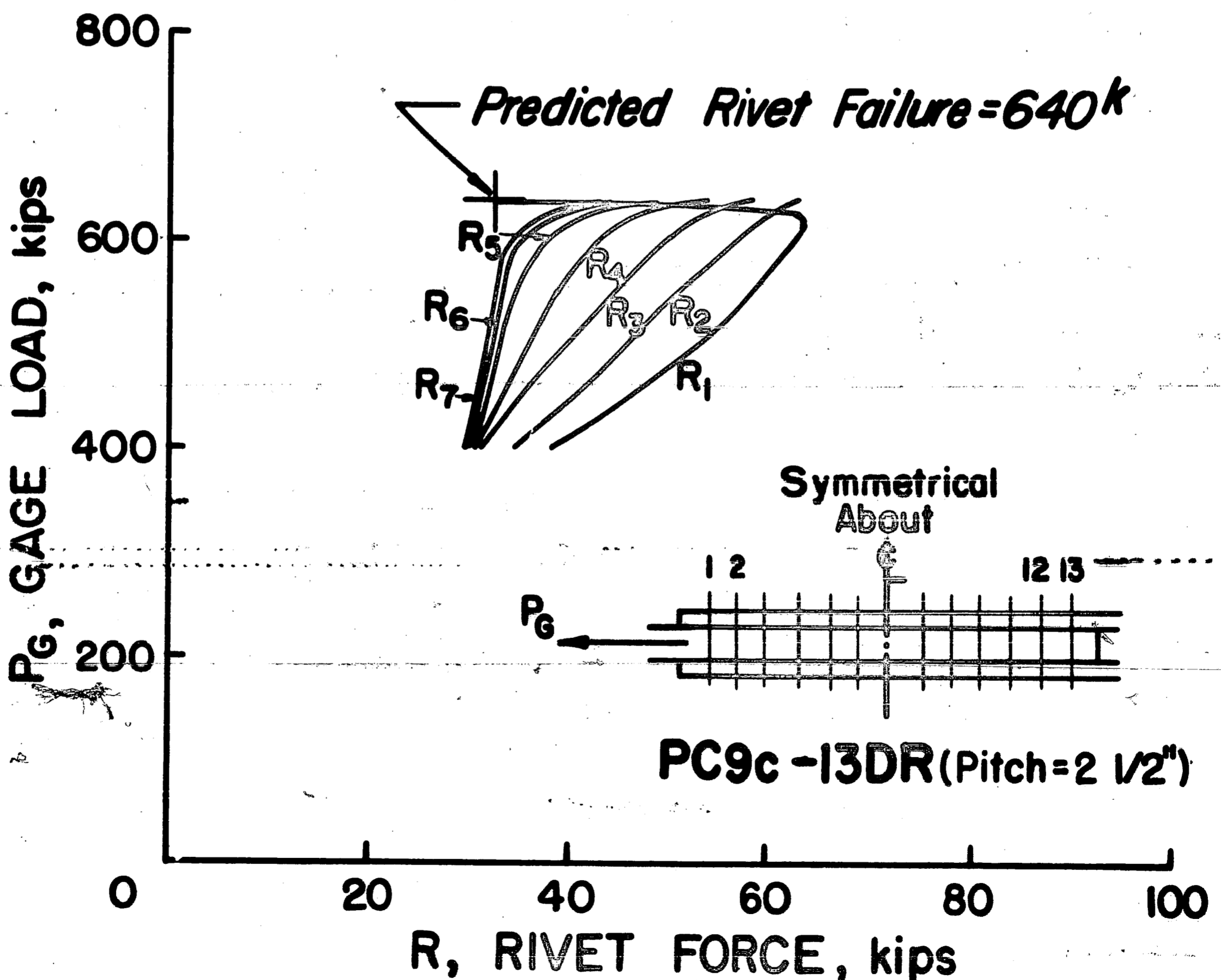
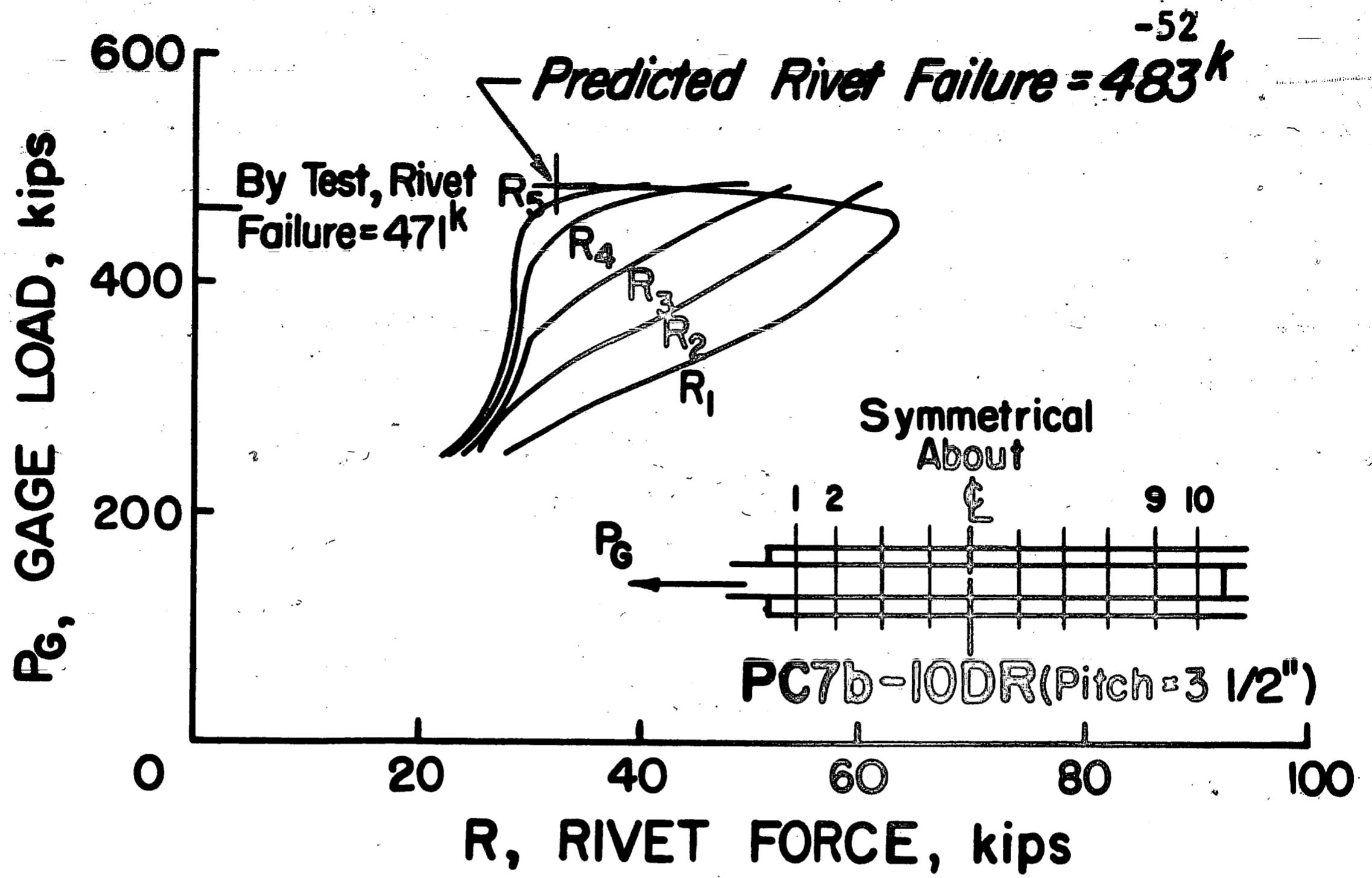

FIG. 5.3 JOINTS PC7b-10DR AND PC9c-13DR,
 THEORETICAL RIVET FORCES

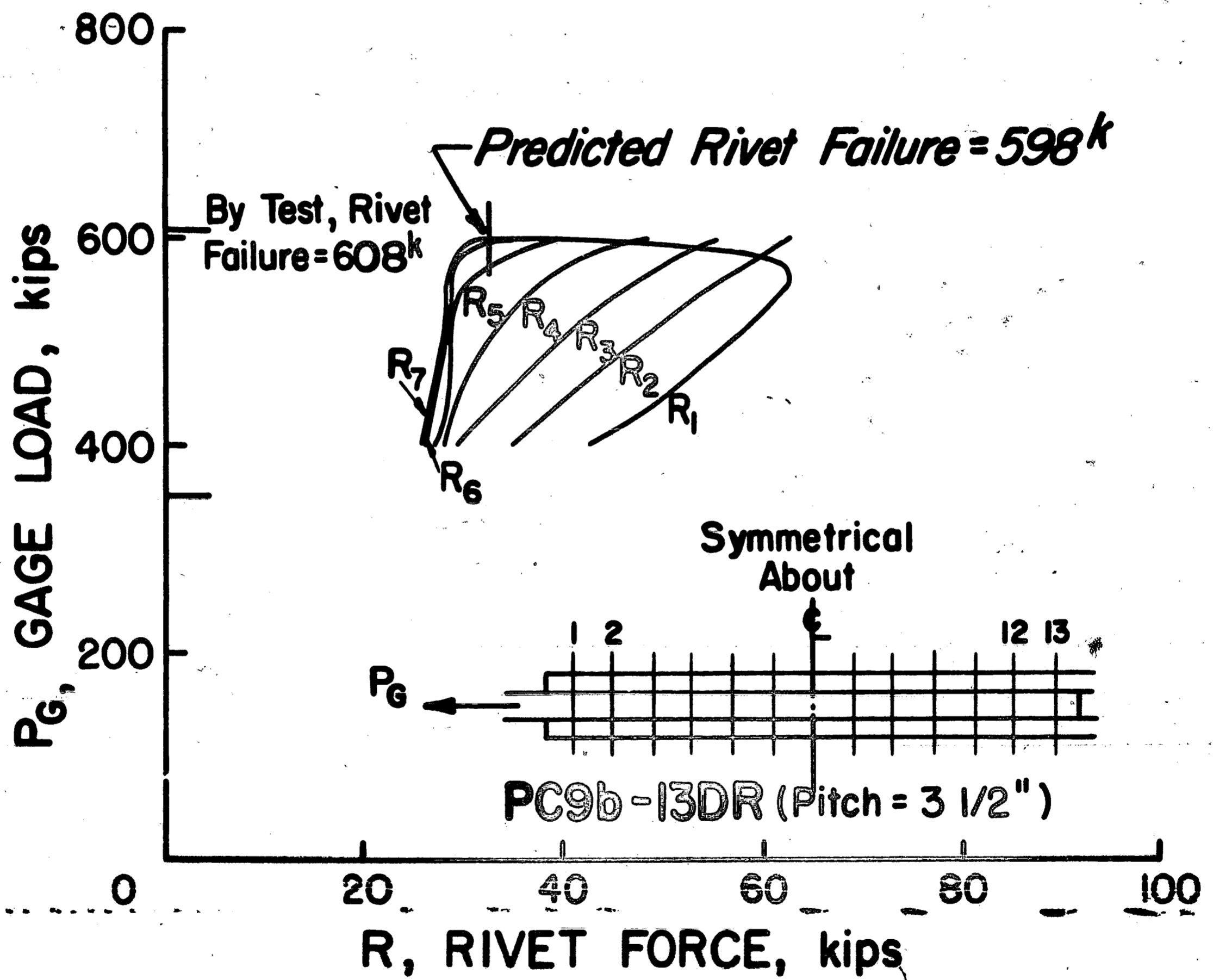

FIG. 5.4 JOINT PC9b-13DR, THEORETICAL RIVET FORCES

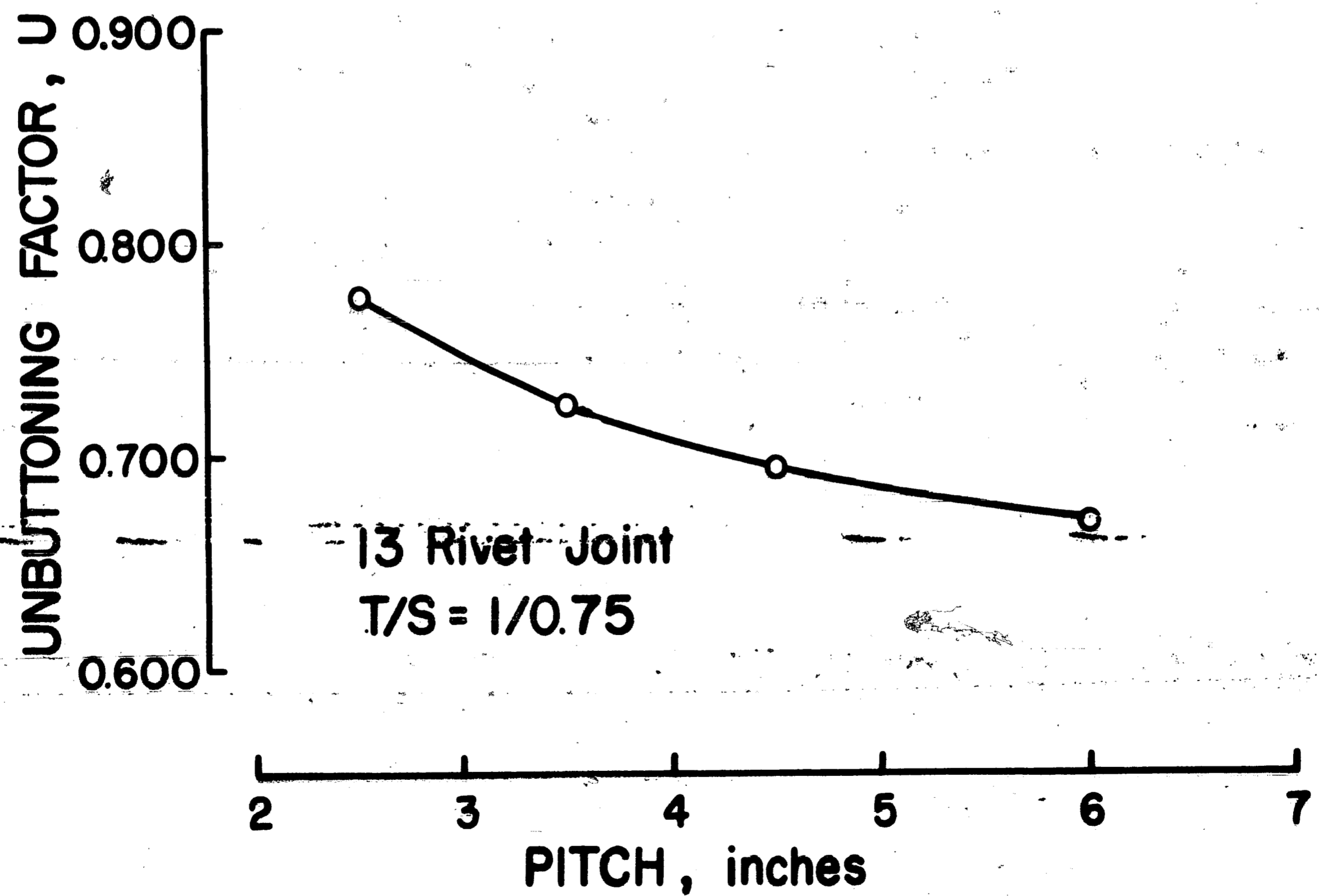
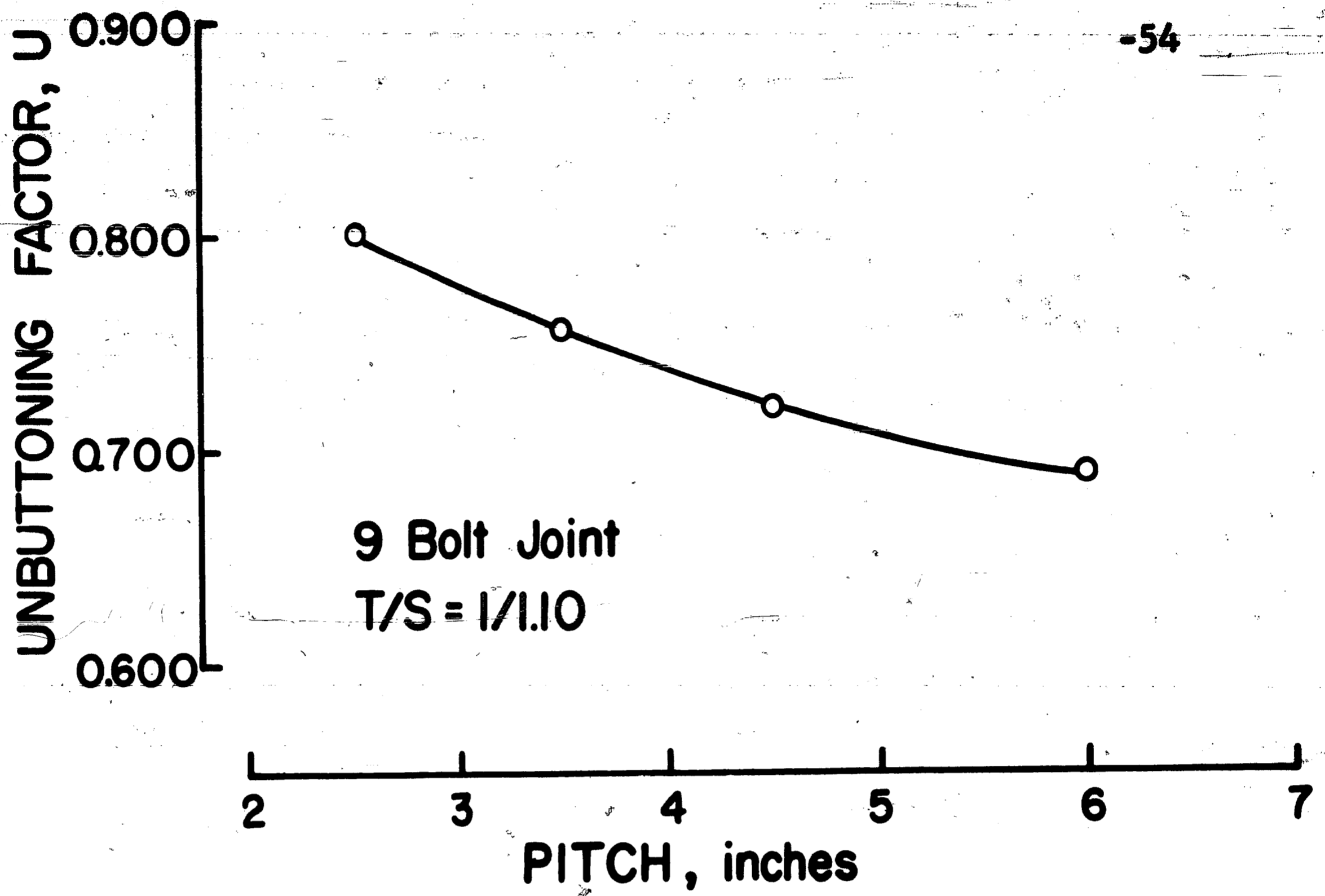

FIG. 5.5 UNBUTTONING FACTOR

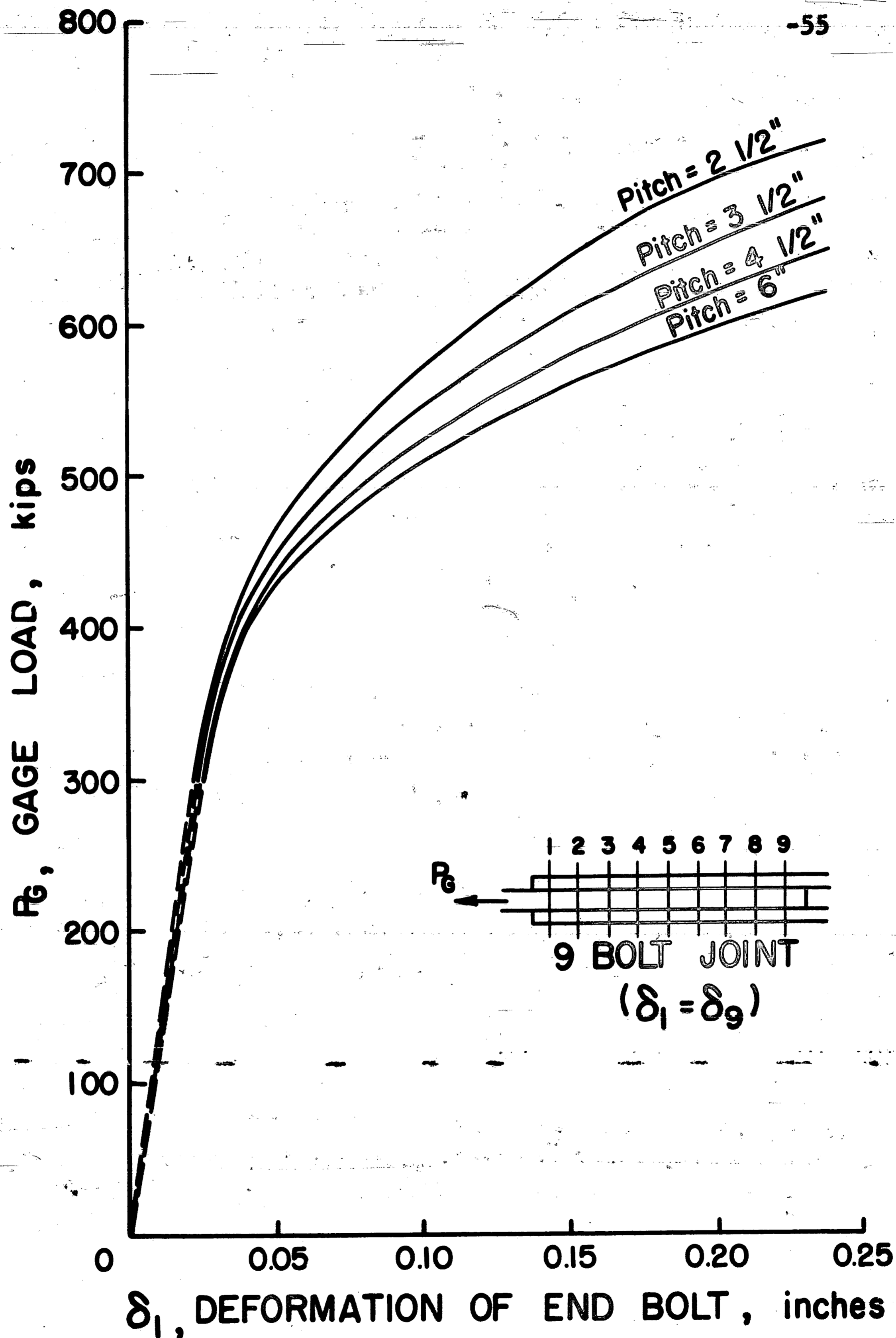

FIG. 5.6 BOLT DEFORMATION

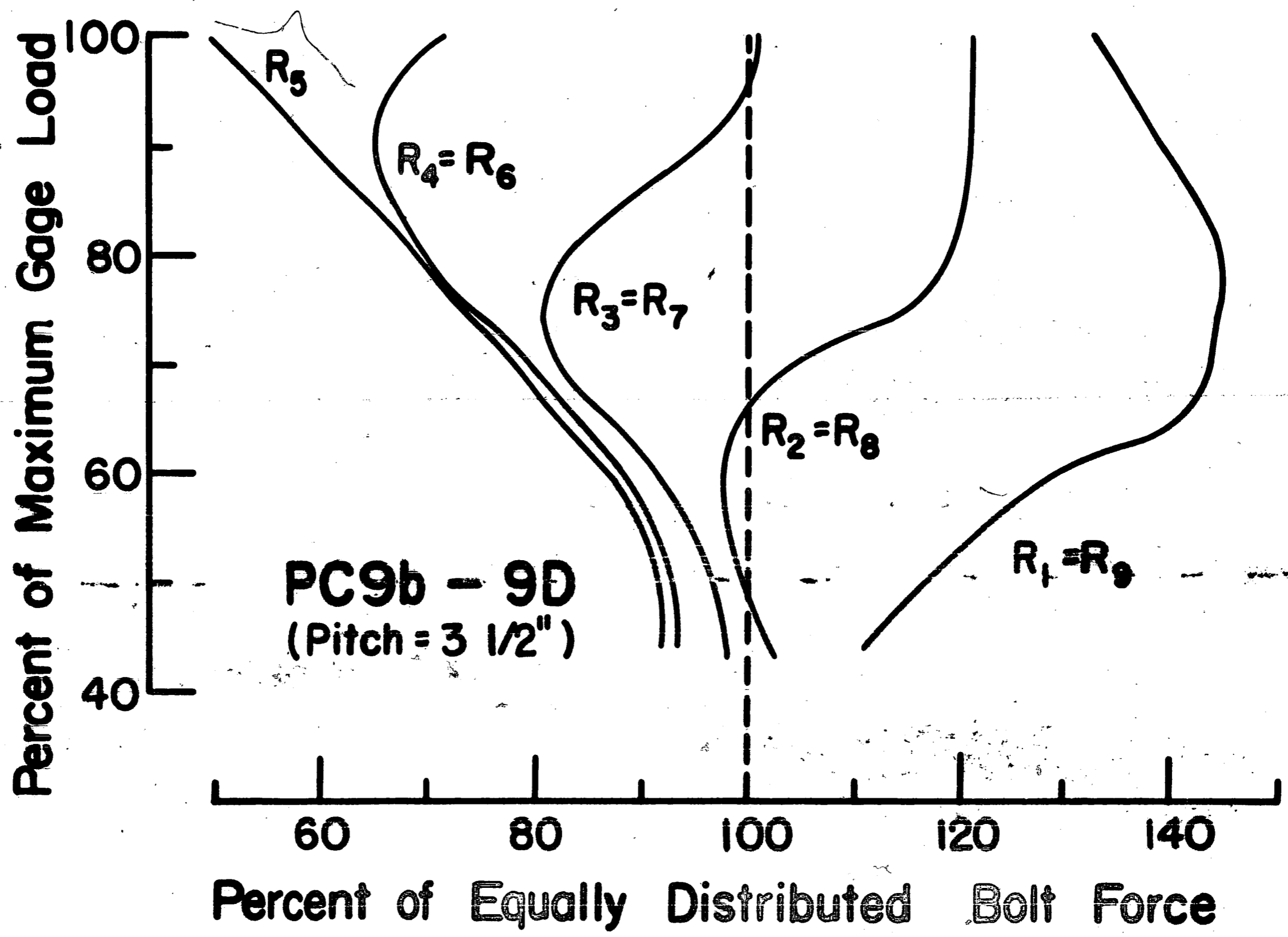
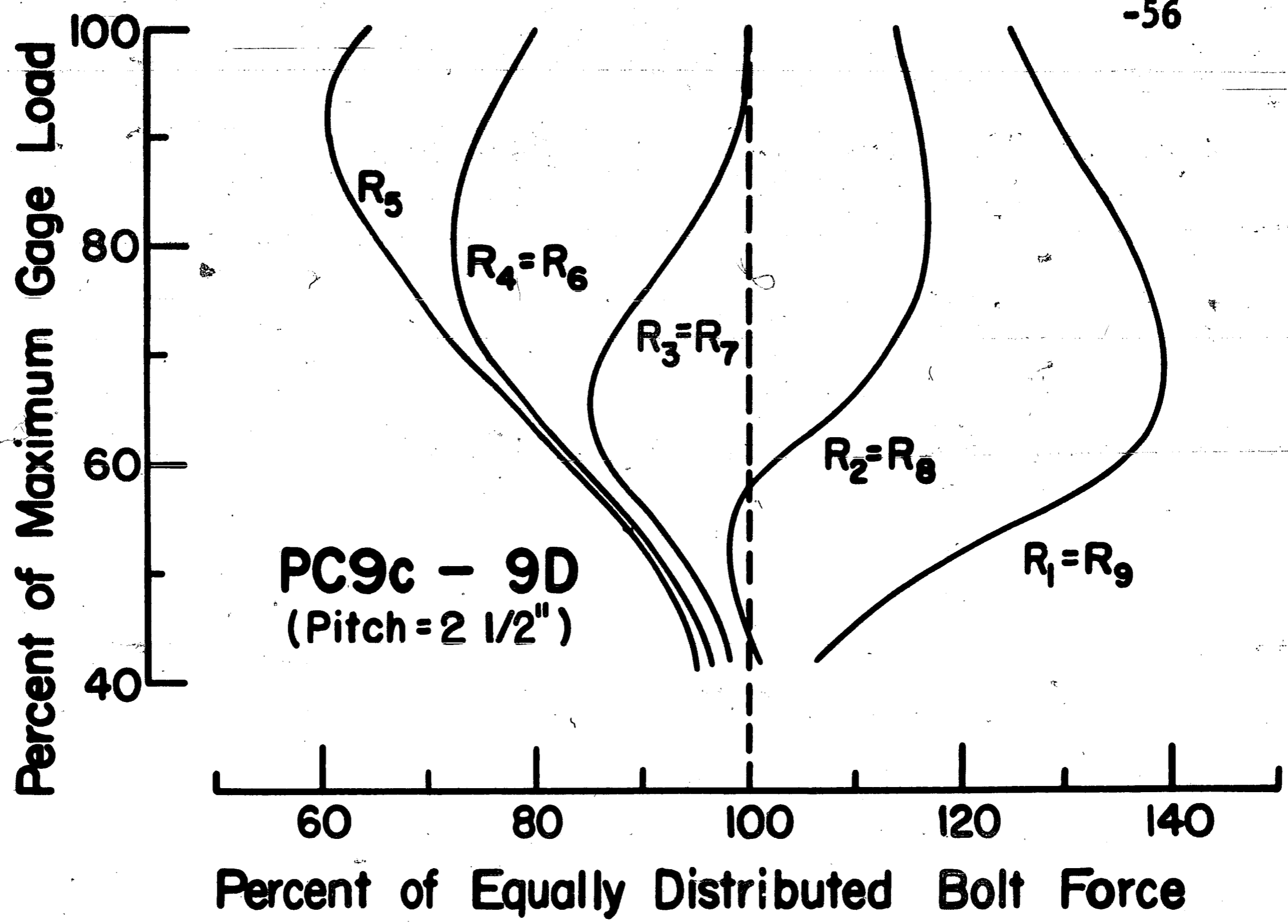

FIG. 5.7 JOINTS PC9c-9D AND PC9b-9D
BOLT FORCE DISTRIBUTION

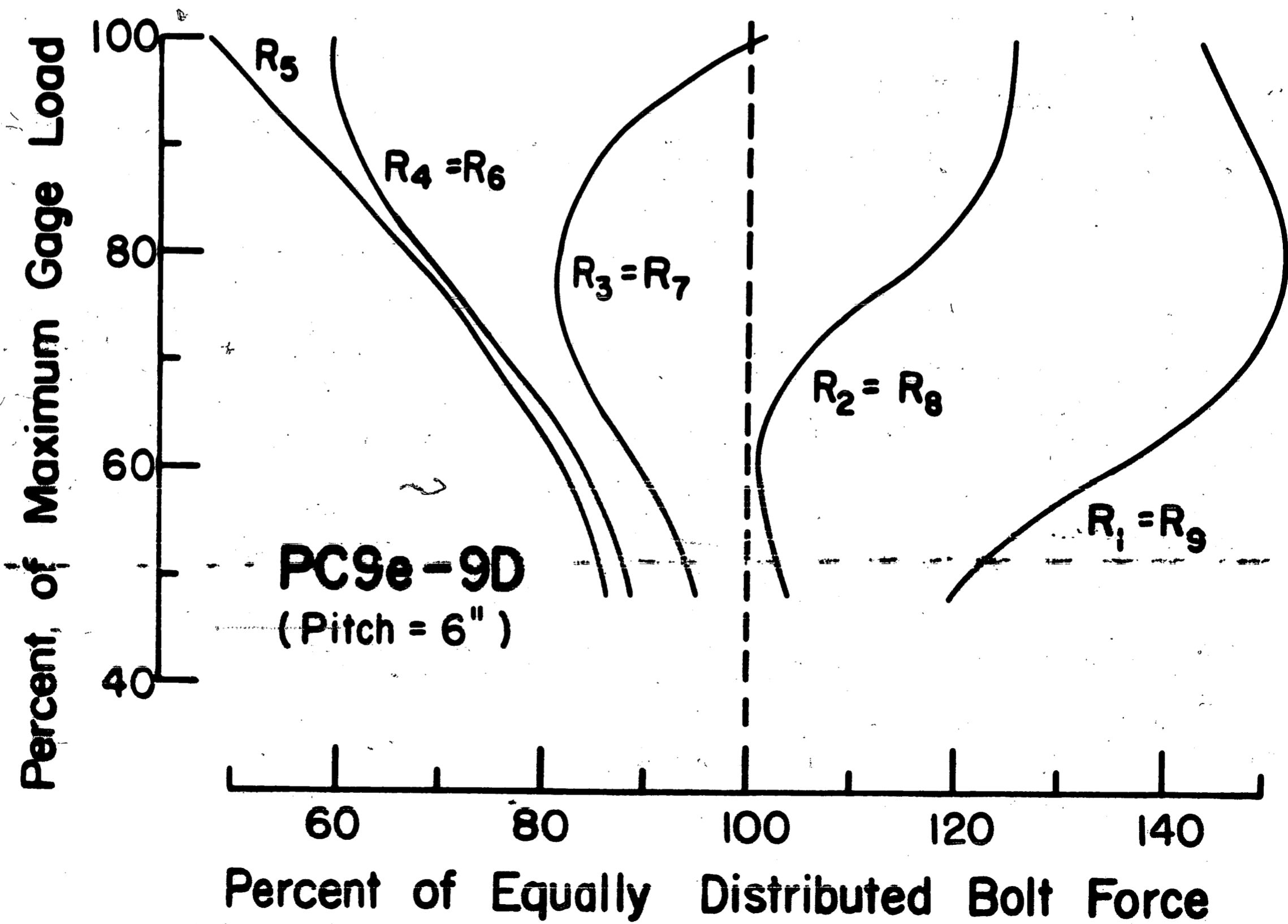
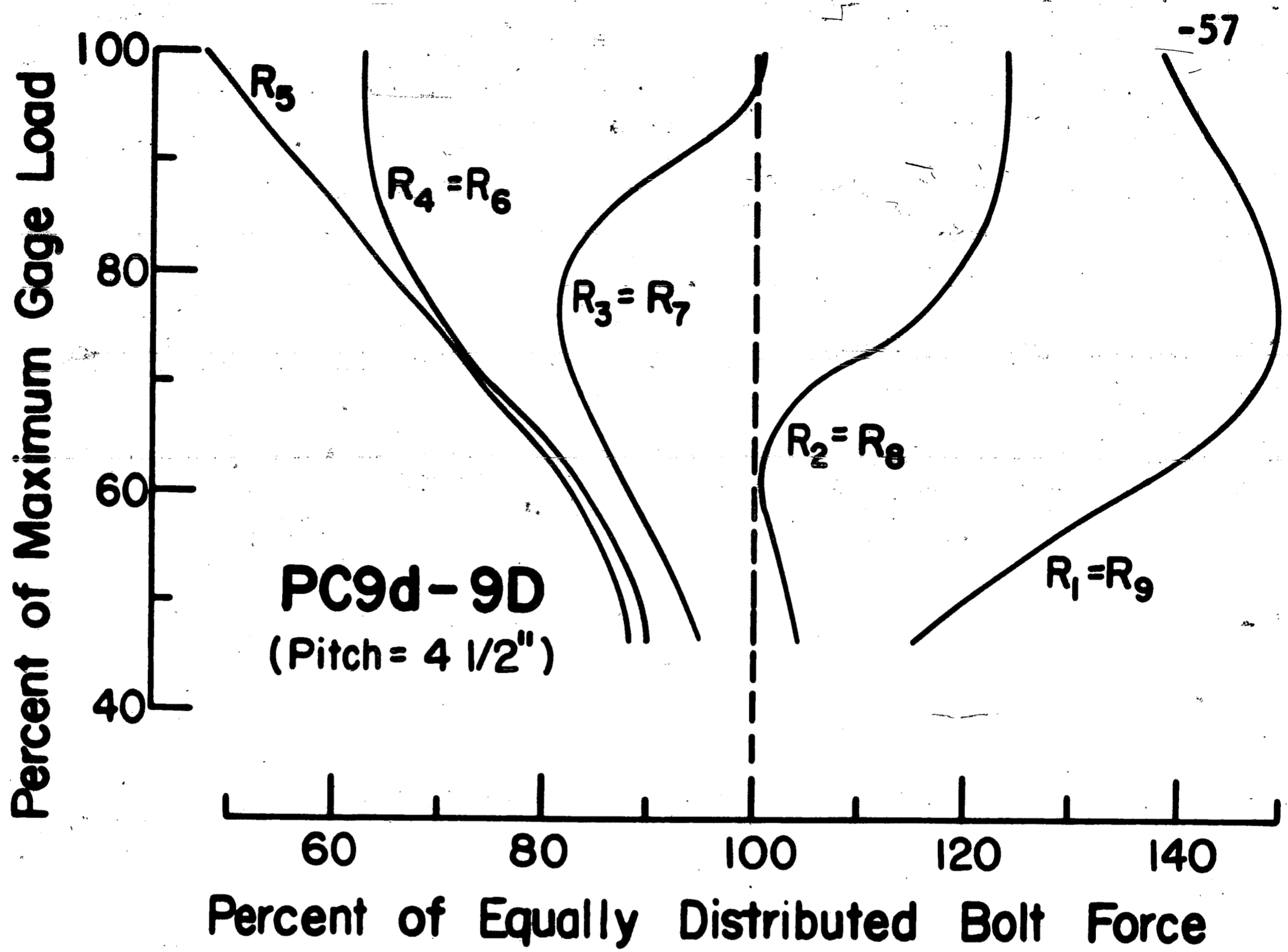

FIG. 5.8 JOINTS PC9d-9D AND PC9e-9D
 BOLT FORCE DISTRIBUTION

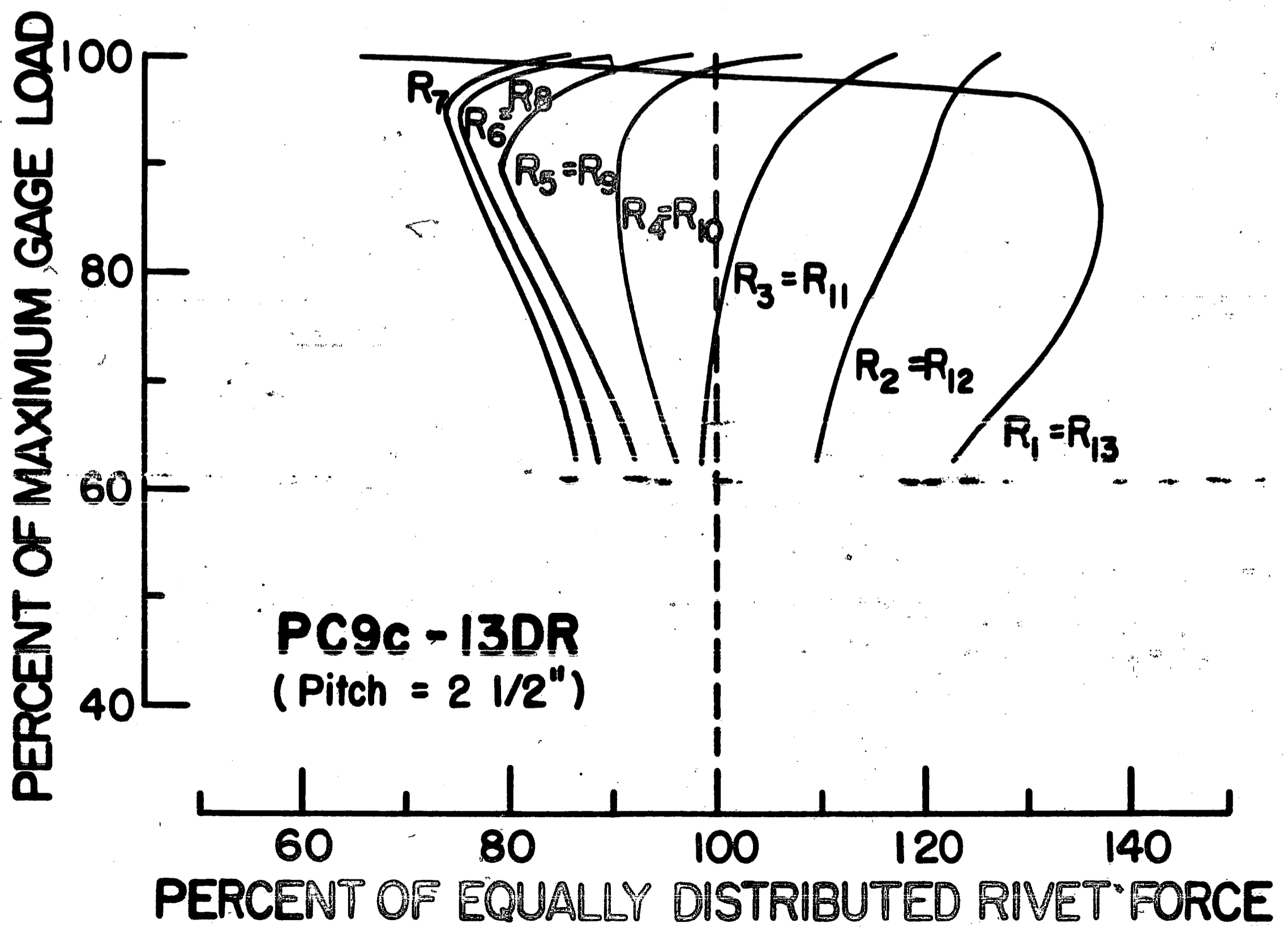
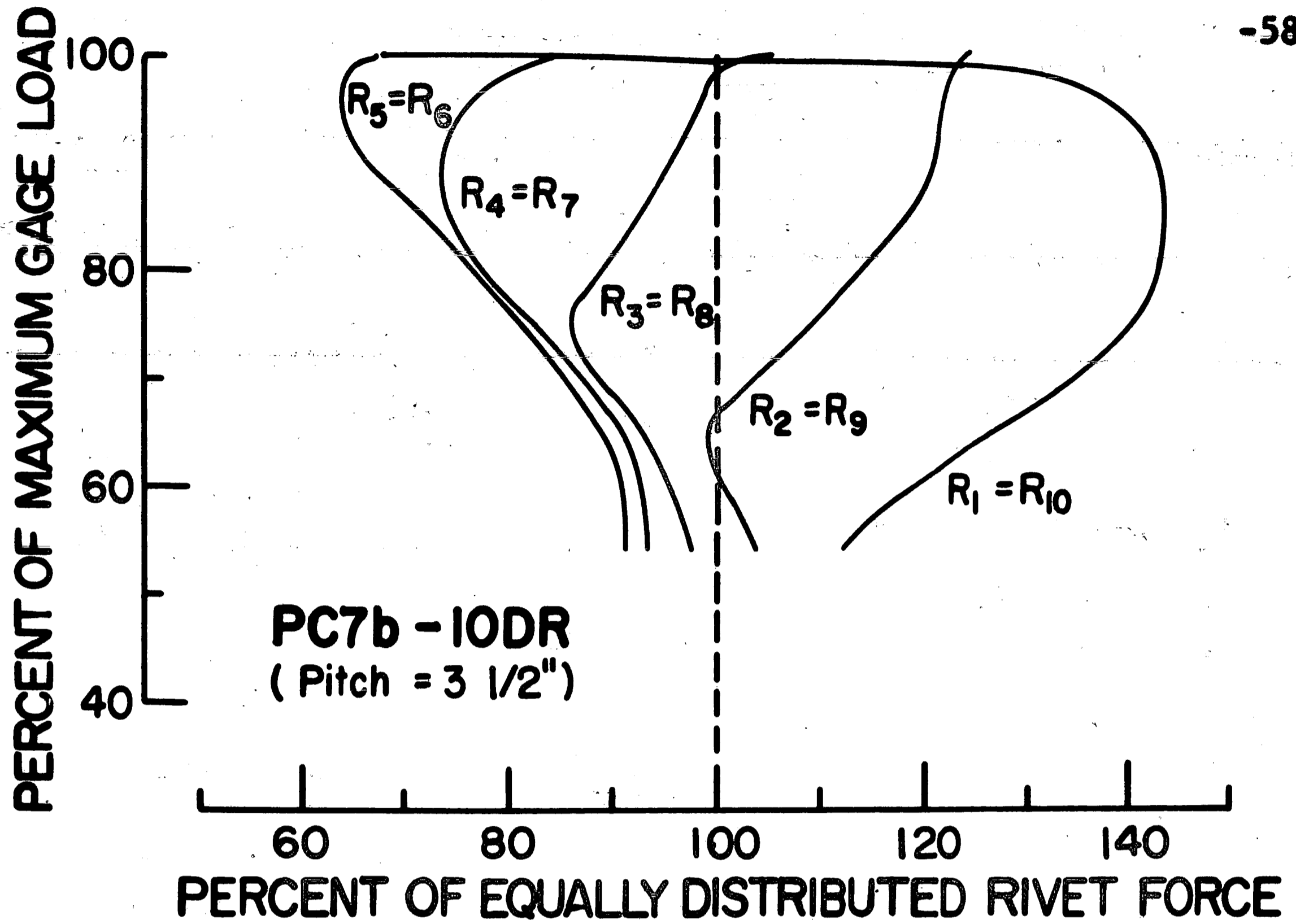

FIG. 5.9 JOINTS PC7b-10DR AND PC9c-13DR,
BOLT FORCE DISTRIBUTION

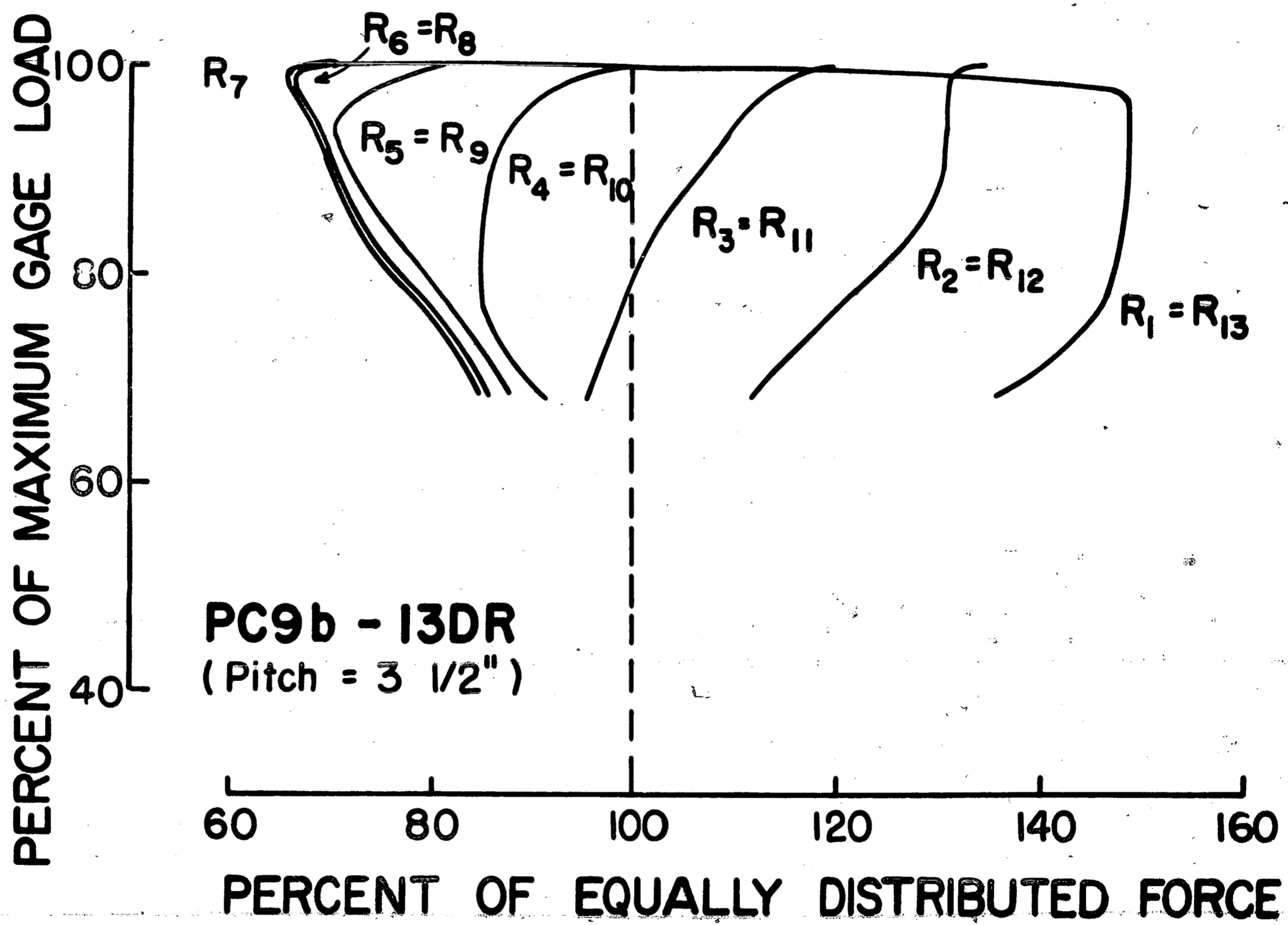

FIG. 5.10 JOINT PC9b-13DR, BOLT FORCE DISTRIBUTION

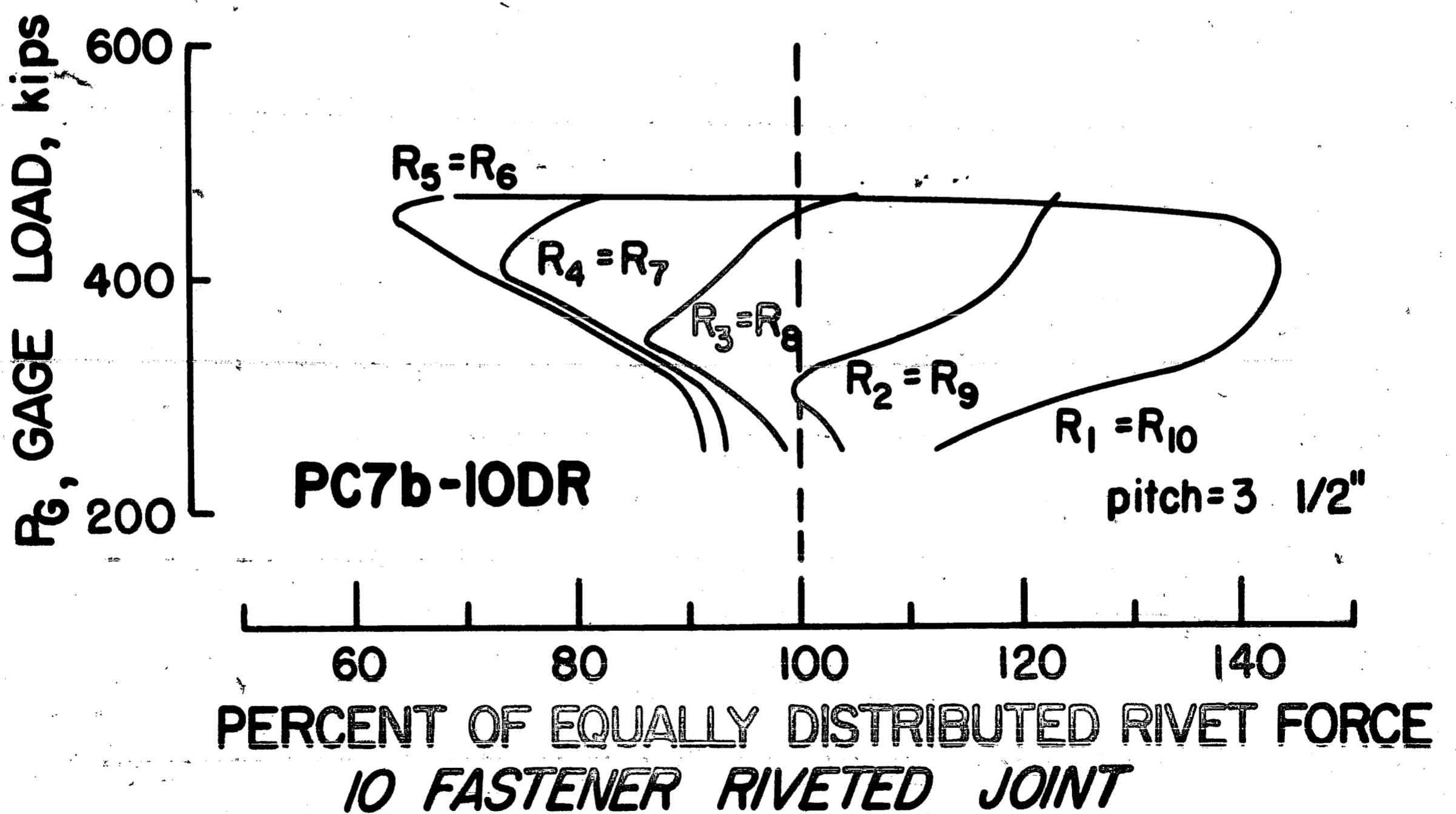
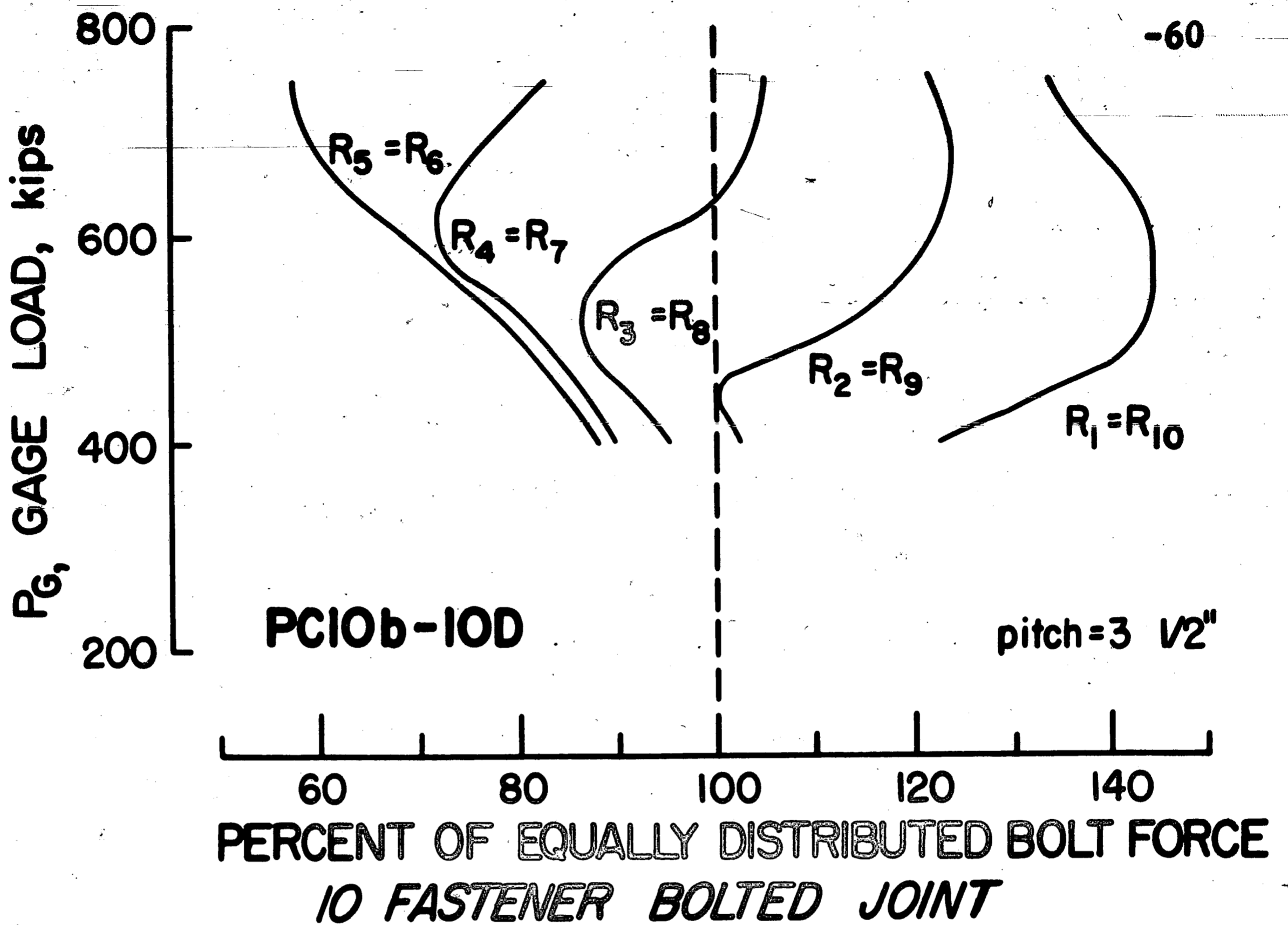

FIG. 5.11 COMPARISON OF BOLT AND RIVET

9. REFERENCES

1. Schutz, F. W.
EFFECTIVE NET SECTION OF RIVETED JOINTS, SRS #30,
University of Illinois, September 1952.
2.
STEEL CONSTRUCTION, American Institute of Steel
Construction, 1956.
3. Davis, R. W.; Woodruff, G. B.; and Davis, H. E.
TENSION TESTS OF LARGE RIVETED JOINTS, Transactions
of ASCE, Vol. 105, p. 1193, 1940.
4. Vasarhelyi, D. D.; Beano, S. Y.; Madison, R. B.;
Lu, Zung-An; and Vasishth, V. C.
EFFECTS OF FABRICATION TECHNIQUES ON BOLTED JOINTS,
Proceedings of ASCE, Vol. 85, ST3, March 1959.
5. Chesson, E., Jr. and Munse, W. H.
BEHAVIOR OF LARGE RIVETED AND BOLTED STRUCTURAL
CONNECTIONS, SRS #174, University of Illinois, June
1959.
6. Bendigo, R. A. and Rumpf, J. L.
STATIC TENSION TESTS OF LONG BOLTED JOINTS, Fritz
Laboratory Report No. 271.8, Lehigh University,
February 1960.
7. Bendigo, R. A. and Rumpf, J. L.
STATIC TENSION TESTS OF BOLTED LAP JOINTS, Fritz
Laboratory Report No. 271.9, Lehigh University,
in preparation.
8. Hansen, R. M. and Rumpf, J. L.
FURTHER STATIC TESTS OF LONG BOLTED JOINTS, Fritz
Laboratory Report No. 271.15, Lehigh University,
in preparation.
9. Dlugosz, S. E. and Rumpf, J. L.
STATIC TENSION TESTS OF LONG RIVETED JOINTS, Fritz
Laboratory Report No. 271.16, Lehigh University,
in preparation.
10. Francis, A. J.
THE BEHAVIOR OF ALUMINUM ALLOY RIVETED JOINTS, The
Aluminium Development Association, Research Report
No. 15, London, 1953.

11. Rumpf, J. L.
THE ULTIMATE STRENGTH OF BOLTED CONNECTIONS, Fritz
Laboratory Report No. 271.14, Lehigh University,
September 1960.

12. Hansen, R. M. and Rumpf, J. L.
SHEAR STRENGTH OF A325 BOLTS, Fritz Laboratory
Report No. 271.10, Lehigh University, in preparation.

VITA

The author was born as the only child of Howard and Ethel Hansen on August 7, 1938.

He was awarded the degree of Bachelor of Civil Engineering by Marquette University in 1959. For a period of time in 1958 and 1959 he also maintained a junior partnership in a private land surveying firm.

In 1959 he was appointed to a research assistantship at Lehigh University and began work toward the degree of Master of Science. For the last two years he has been assigned to the "Large Bolted Joints" project.

In August 1960 he was married to Barbara Kovach.