

1972

Hydraulic performance of highway drainage inlets used in pennsylvania

Peter P. Yee
Lehigh University

Follow this and additional works at: <https://preserve.lehigh.edu/etd>



Part of the [Civil Engineering Commons](#)

Recommended Citation

Yee, Peter P., "Hydraulic performance of highway drainage inlets used in pennsylvania" (1972). *Theses and Dissertations*. 4034.
<https://preserve.lehigh.edu/etd/4034>

This Thesis is brought to you for free and open access by Lehigh Preserve. It has been accepted for inclusion in Theses and Dissertations by an authorized administrator of Lehigh Preserve. For more information, please contact preserve@lehigh.edu.

SUMMARY

An experimental investigation of the performances of some highway drainage inlets is presented. The purpose of this study is to provide information to aid in the design of spacings of highway drainage inlets. The channel considered is triangular in cross-section with one side slope having slopes ranging from 48:1 to 12:1. The other side slope (back slope) has a slope of either 1/8:1 or 3:1.

The drainage inlets to be studied were (1) Type J Inlet, (2) 4-Ft Special Inlet, and (3) 6-Ft Special Inlet. They are standard inlets used by the Pennsylvania Department of Transportation and are customarily installed in paved channels.

Model inlets were built to half the size of actual inlets. Each inlet was tested under a variety of channel configurations and with a certain range of channel flow rates. The capacity of an inlet can be determined by actual measurements, and thus the efficiency of an inlet can be obtained.

A series of efficiency curves given with Figures 4.1 to 4.12 are presented as a result of this study. It is anticipated that such knowledge will provide information that is more adequate to the designer in determining the spacing of highway drainage inlets than the information presently available.

HYDRAULIC PERFORMANCE OF HIGHWAY DRAINAGE INLETS
USED IN PENNSYLVANIA

by

Peter P. Yee

A Thesis
Presented to the Graduate Committee
of Lehigh University
in Candidacy for the Degree of
Master of Science

in
Civil Engineering

Lehigh University
1972

CERTIFICATE OF APPROVAL

This thesis is accepted and approved in partial fulfillment
of the requirements for the degree of Master of Science

Date 24th Jan, 1972

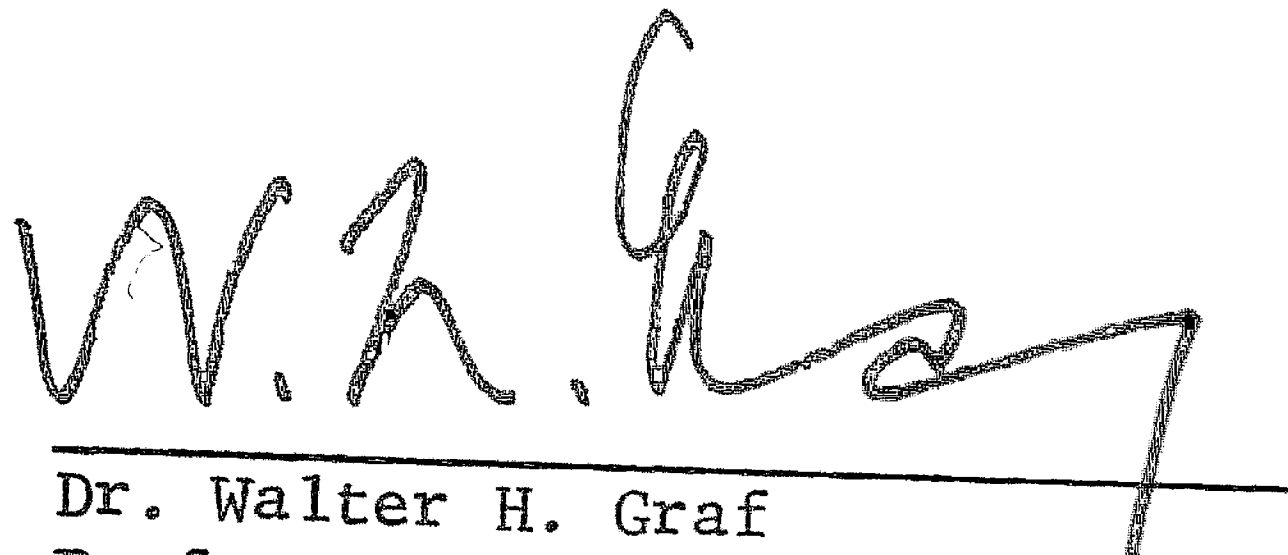
Dr. Walter H. Graf
Professor in Charge



Dr. David A. VanHorn,
Chairman
Department of Civil Engineering

TABLE OF CONTENTS

	<u>Page</u>
CERTIFICATE OF APPROVAL	II
SUMMARY	III
ACKNOWLEDGEMENTS	VII
LIST OF FIGURES	VIII
LIST OF TABLES	IX
1. INTRODUCTION	1
1.1 Background and Need for Investigation	1
1.2 Scope of Study	2
2. MODEL LAWS	4
2.1 General Remarks	4
2.2 Principles of Hydraulic Similitude	5
2.2.1 Geometrical Similarity	6
2.2.2 Kinematic Similarity	7
2.2.3 Dynamic Similarity	7
2.3 Dimensionless Numbers	8
2.4 Froude Similitude	10
2.5 Manning Similitude	11
2.6 Concluding Remarks	16
3. EXPERIMENTAL INVESTIGATION	17
3.1 Inlets	17
3.1.1 Type 4 ft. Special and Type 6 ft. Special	17
3.1.2 Type J Inlets	21
3.2 Laboratory Equipment	23
3.2.1 General Requirements	23
3.2.2 Apparatus	24
3.2.3 Model Construction	28
3.3 Technique	31
3.3.1 Flow Measurements	31
3.3.2 Depth Measurements	31
3.4 Procedure	32
4. RESULTS AND DISCUSSION	34
4.1 Experimental Results	34
4.2 Discussion of Measurements	35
4.2.1 Flow Measurements	35
4.2.2 Depth Measurements	35
4.3 Efficiencies of Inlets	36
4.3.1 Efficiencies of Type J Inlet	37
4.3.2 Efficiencies of 4-ft Special Inlet and 6-ft Special Inlet	38

TABLE OF CONTENTS (continued)

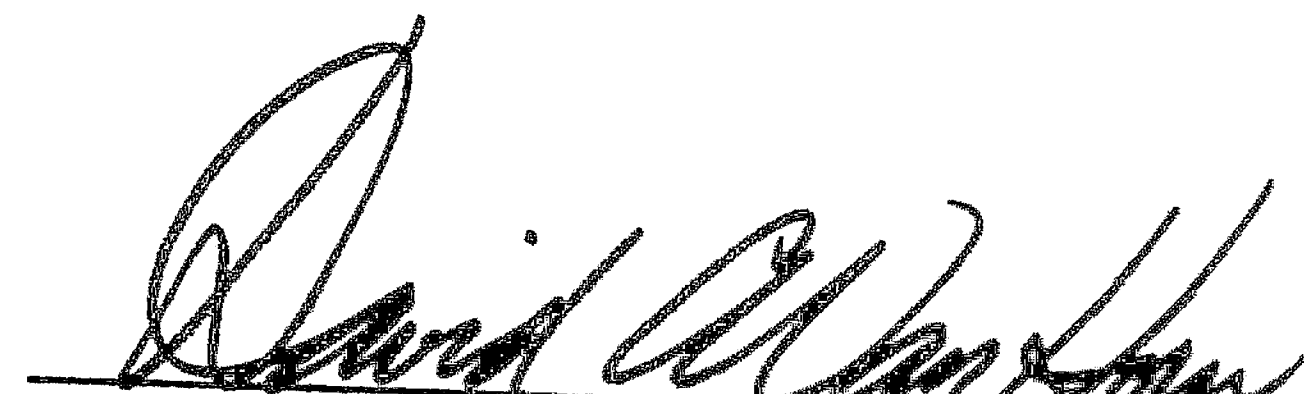
	<u>Page</u>
5. LIST OF RECURRING SYMBOLS	
6. BIBLIOGRAPHY	56
7. APPENDIX - EXPERIMENTAL DATA	57
8. VITA	58
	131

SUMMARY

An experimental investigation of the performances of some highway drainage inlets is presented. The purpose of this study is to provide information to aid in the design of spacings of highway drainage inlets. The channel considered is triangular in cross-section with one side slope having slopes ranging from 48:1 to 12:1. The other side slope (back slope) has a slope of either 1/8:1 or 3:1.

The drainage inlets to be studied were (1) Type J Inlet, (2) 4-Ft Special Inlet, and (3) 6-Ft Special Inlet. They are standard inlets used by the Pennsylvania Department of Transportation and are customarily installed in paved channels.

Model inlets were built to half the size of actual inlets. Each inlet was tested under a variety of channel configurations and with a certain range of channel flow rates. The capacity of an inlet can be determined by actual measurements, and thus the efficiency of an inlet can be obtained.

A series of efficiency curves given with Figures 4.1 to 4.12 are presented as a result of this study. It is anticipated that such knowledge will provide information that is more adequate to the designer in determining the spacing of highway drainage inlets than the information presently available.

ACKNOWLEDGEMENTS

This study was sponsored by the Pennsylvania Department of Transportation in conjunction with the United States Federal Highway Administration. It was conducted in the Fritz Engineering Laboratory (Department of Civil Engineering) of Lehigh University at Bethlehem, Pennsylvania.

The writer is deeply indebted to Professors Arthur W. Brune and Walter H. Graf under whose direction this study was conducted.

Dr. Stephen C. Ko made many helpful suggestions in the experimental phase of the work, especially in connection with the design of the model and with the arrangement of the apparatus.

The writer also wishes to thank especially Mr. Elias Dittbrenner who built the model, Mr. John M. Gera who prepared the drawings, and Mrs. Jane Lenner and Miss Shirley Matlock who typed the manuscripts.

LIST OF FIGURES

<u>Figure</u>	<u>Title</u>	<u>Page</u>
2.1	Similitude of Highway Drainage Inlet	6
3.1	Model Inlet Grates	18
3.2	Installation for Type 4-Ft Special Inlet and Type 6-Ft Special Inlet	20
3.3	Installation for Type J Inlet	22
3.4	Schematic Diagram	25
3.5	Cutaway View of Testing Tank	27
3.6	Testing Tank with Channel and Inlet Grate	30
4.1	Efficiency Curves; Type J Inlet (Long. Slope = $\frac{1}{2}\%$)	44
4.2	Efficiency Curves; Type J Inlet (Long. Slope = 2%)	45
4.3	Efficiency Curves; Type J Inlet (Long. Slope = 4%)	46
4.4	Efficiency Curves; Type J Inlet (Long. Slope = 8%)	47
4.5	Efficiency Curves; 4-Ft Special (Long. Slope = $\frac{1}{2}\%$)	48
4.6	Efficiency Curves; 4-Ft Special (Long. Slope = 2%)	49
4.7	Efficiency Curves; 4-Ft Special (Long. Slope = 4%)	50
4.8	Efficiency Curves; 4-Ft Special (Long. Slope = 8%)	51
4.9	Efficiency Curves; 6-Ft Special (Long. Slope = $\frac{1}{2}\%$)	52
4.10	Efficiency Curves; 6-Ft Special (Long. Slope = 2%)	53
4.11	Efficiency Curves; 6-Ft Special (Long. Slope = 4%)	54
4.12	Efficiency Curves; 6-Ft Special (Long. Slope = 8%)	55

LIST OF TABLES

<u>Table</u>	<u>Title</u>	<u>Page</u>
2.1	Model Scale for Froude Manning Similarity and Manning Similarity	12
2.2	Manning's Roughness Coefficients	15
3.1	Standard Inlets	19
3.2	Order of Testing	21
4.1	Comparison of Efficiencies of Inlet--Type J Inlet	41
4.2	Comparison of Efficiencies of Inlet--4-Ft Special	42
4.3	Comparison of Efficiencies of Inlet--6-Ft Special	43

1. INTRODUCTION

1.1 Background and Need for Investigation

Runoff from rainfall can flow from highways into storm drainage systems through the drainage inlets which are placed at intervals along the roadside. Not uncommonly any particular drainage inlet is unable to accept all the water that comes to it owing to the limited capacity of the inlet and to clogging of the inlet openings by debris. The inability of the inlet to accept all the oncoming water can produce or lead to some undesirable conditions, such as, (1) encroachment of water onto the roadway pavement, thus creating safety hazards, (2) seepage of water into the subbase section of the highway, thus increasing the pore-water pressure of the soil aggregates, which might lead to premature failure of the highway, and (3) flooding of a low-lying area if water can not be completely drained from the highway by successive inlets placed along the roadside.

Design and spacing of drainage inlets have been governed by several factors, such as, (1) the assumed capacity of an inlet based on past experience, (2) the structural strength of the inlet gratings, (3) the effect of the inlet on traffic, (4) the effect of the inlet on pedestrians, and (5) the cost of installation. At present the true capacities of many existing inlets are still unknown. Designers commonly assume that an inlet has a certain capacity regardless of the channel configuration, and little attention is paid to the carryover at an inlet; carryover being the water that by-passes the

drainage inlet. Obviously, the capacity of any drainage inlet must be thoroughly understood if the spacing of inlets is to be set forth on a basis sounder than the current one.

An analytical approach to finding the capacities of an inlet is almost impossible if one considers the numerous variables that are involved, such as the longitudinal slope of the channel, the swale slope, the back slope, and the roughness of the channel. The sizes of the inlet and the different patterns of openings further complicate the whole matter. An alternative solution to the problem is actually testing a drainage inlet. Although that procedure can be followed under some conditions, other conditions indicate using models which are smaller in size than the prototypes.

Investigations of the performances of drainage inlets have been conducted by many researchers; prominent among them are the studies by LARSON et al. (1949), GUILLOU (1959), researchers at JOHN HOPKINS UNIVERSITY (1956 and 1967), and U S ARMY CORPS OF ENGINEERS (1964). An extensive literature survey was made by YÜCEL et al. (1969). Inasmuch as the studies mentioned dealt with specific inlets, the results of those studies can not very well be made applicable to other inlets owing to the differences present between many inlets.

1.2 Scope of Study

This study deals primarily with determining the capacities of inlets by means of actually testing models of inlets. Six standard drainage inlets used by the Pennsylvania Department of Transportation

(see Section 3.1) will be tested in the laboratory under a variety of conditions. Three of the inlets are customarily installed in paved channels. They are (1) Type 4-Ft Special, (2) Type 6-Ft Special, and (3) Type J. (See Figures 3.1, 3.2, and 3.3). The remaining three inlets, (1) Type H, (2) Type 4-Ft, and (3) Type 6-Ft, are installed on grassed channels. This study deals exclusively with the three inlets that are installed in paved channels.

No attempt was made to alter the geometry or the installation of any inlet tested in order to produce an increase in capacity of the inlet. All inlets were modelled according to specifications, and they were tested under a number of channel conditions and with a certain range of channel flow rates.

All inlet models were built with a prototype : model length ratio of 2:1. The knowledge of model laws was used to correlate model parameters to prototype parameters. As a result some form of efficiency curves are presented. It is anticipated that knowledge, such as that gained in this study, will probably lead to a better design of spacing of inlets.

2. MODEL LAWS

2.1 General Remarks

The use of models in hydraulic research is popular and common. Commonly, investigators find that certain flow phenomena cannot be studied because either (a) analytical methods are inherently inadequate, that is, the existing equations of fluid mechanics cannot be made applicable, or (b) experimental data are insufficient. The justification for the use of models is an economic one. Although in a few exceptions the size of the models is made larger than the size of the prototypes, models are usually made smaller than the prototypes. Another justification for the use of models is that testing of models can be done more readily in the laboratory. The results of such tests might even be used to check or to compare analytical results.

The cost in employing models is usually higher than that of analytical investigations. If the latter is deemed adequate in studying certain flow phenomena, then the use of models is not recommended.

The main purpose in modeling is to correlate model behavior to prototype behavior by means of basic principles of similitude. Once a prototype:model scale ratio is known, a relatively simple detailed interpretation of model measurements can be made. These results in turn can be translated into different physical quantities, such as velocity or discharge, in the corresponding prototype.

Numerous references deal with model laws and modeling. Those found to be particularly useful in this study are STEVENS et al. (1942), MORRIS (1963), HENDERSON (1966), VENNARD (1966), and GRAF (1971).

In the present study of highway drainage inlets, a prototype:model (length) ratio of 2:1 is used. Several factors were considered in establishing this ratio, such as, (a) the space available for testing a model, (b) the maximal discharge available in the laboratory, (c) the cost of fabrication and operation of the model, and (d) the effect of surface tension.

2.2 Principles of Hydraulic Similitude

Hydraulic similitude is the basic tool for correlating physical quantities between the model and the prototype. It can also be applied in cases where the linear scale ratio for vertical dimensions is different from that for horizontal dimensions; such models are referred to as distorted models. However, no distortion in the scales is used in the present study.

In order to correlate flow phenomena between model and prototype, three types of similitudes are involved; they are, geometrical similitude, kinematic similitude, and dynamic similitude. If complete similarity is desired between model and prototype, all three of the above similitudes must be satisfied. Each of the three will be discussed briefly in the following.

2.2.1 Geometrical Similarity

Two objects are said to be geometrical similar provided the ratios of corresponding dimensions are equal. In the model and prototype of Fig. 2.1, for example,

$$\frac{L_p}{L_m} = \frac{D_p}{D_m} = L_R = \frac{l_p}{l_m} \quad (1)$$

where L and D denote the length of inlet and any depth of water, respectively, and l is a characteristic length. The subscripts, p and m , refer to prototype and model, respectively. L_R is the scale ratio.

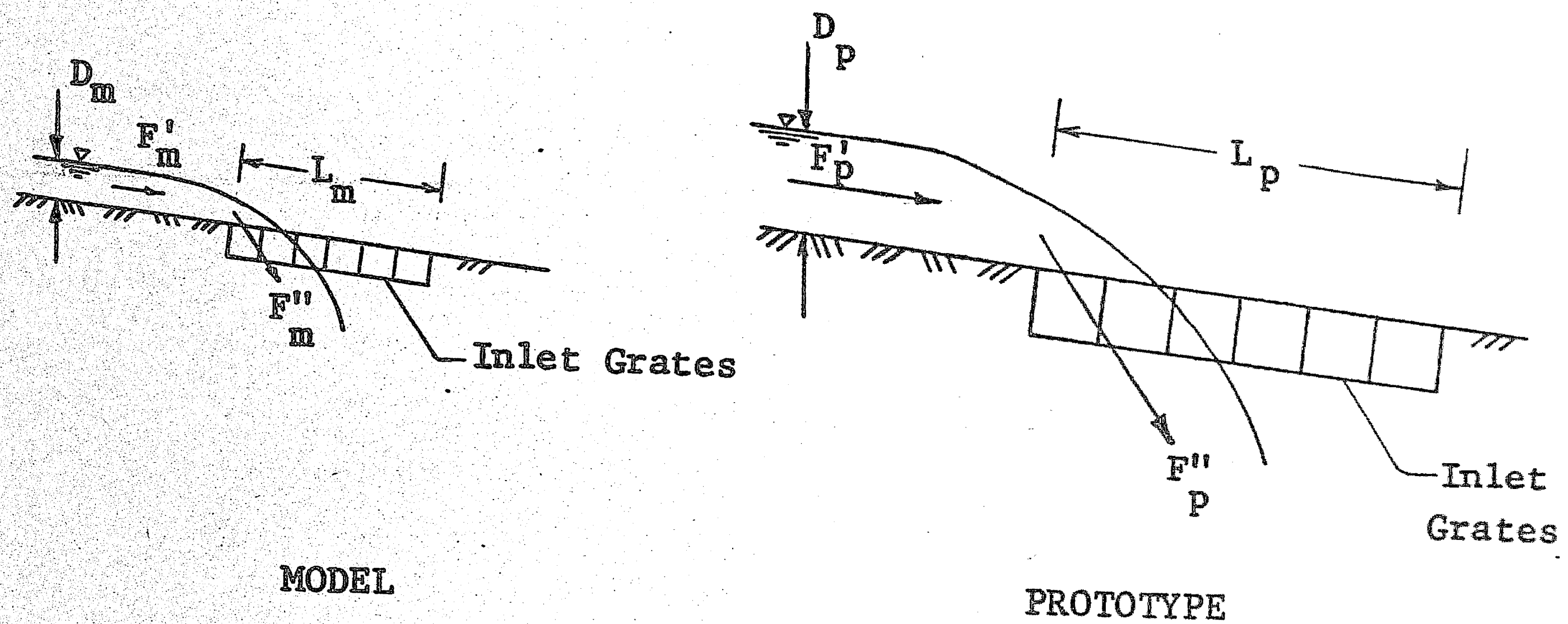

Fig. 2.1: Similitude of Highway Drainage Inlet

Corollaries of geometric similarity imply similarity of corresponding areas and volumes, such as:

$$\frac{A_p}{A_m} = L_R^2, \text{ and} \quad (2)$$

$$\frac{V_p}{V_m} = L_R^3, \quad (3)$$

where A and V denote area and volume, respectively.

2.2.2 Kinematic Similarity

Two flow phenomena are said to be kinematically similar provided (1) that the flow fields have the same shape, and (2) that the prototype:model ratios of corresponding velocities and accelerations are the same.

2.2.3 Dynamic Similarity

Dynamic similarity exists between model and prototype provided the prototype:model ratio of corresponding forces are the same. The force ratios shown in Fig. 2.1 may be written as:

$$\frac{F'_p}{F'_m} = \frac{F''_p}{F''_m} \quad (4)$$

where F'_m and F''_m are two forces in the flow field of the model, and F'_p and F''_p are the corresponding forces in the corresponding flow field of the prototype. Owing to Newton's Law (Force = Mass x Acceleration), Eq. (4) requires that geometric and kinematic similarities be maintained between flow fields. In other words, dynamic similarity between prototype and model exists provided identical types of forces are parallel and have the same prototype:model ratio at all points in the corresponding flow fields.

2.3 Dimensionless Numbers

The forces which affect a flow field are those due to pressure, F_P , inertia, F_I , gravity, F_G , viscosity, F_V , elasticity, F_E , and surface tension, F_T . These forces are given by the following fundamental relationships:

$$F_P = (\Delta P) A = (\Delta P) \ell^2 \quad (5)$$

$$F_I = Ma = \rho \ell^3 \left(\frac{v}{\ell}\right)^2 = \rho v^2 \ell^2 \quad (6)$$

$$F_G = Mg = \rho \ell^3 g \quad (7)$$

$$F_V = \mu \left(\frac{dv}{dy}\right) A = \mu \left(\frac{v}{\ell}\right) \ell^3 = \mu v \ell \quad (8)$$

$$F_E = EA = E\ell^2 \quad (9)$$

$$F_T = \sigma \ell \quad (10)$$

where ΔP is a pressure difference; A is an area; ℓ is a characteristic length; ρ is density; M is a mass; a is acceleration; g is gravitational acceleration; μ is dynamic viscosity; E is the modulus of elasticity; and σ is the surface tension.

In the present study, the effects of elastic force, F_E , and of surface tension, F_T , can safely be neglected.

It has been stated previously that dynamic similarity implies similarity of forces; therefore, one may write:

$$\left(\frac{F_I}{F_P}\right)_P = \left(\frac{F_I}{F_P}\right)_M ; \left(\frac{\rho v^2}{\Delta P}\right)_P = \left(\frac{\rho v^2}{\Delta P}\right)_M , \quad (11)$$

$$\left(\frac{F_I}{F_V}\right)_P = \left(\frac{F_I}{F_V}\right)_M ; \left(\frac{v\rho l}{\mu}\right)_P = \left(\frac{v\rho l}{\mu}\right)_M , \text{ and} \quad (12)$$

$$\left(\frac{F_I}{F_G}\right)_P = \left(\frac{F_I}{F_G}\right)_M ; \left(\frac{v^2}{lg}\right)_P = \left(\frac{v^2}{lg}\right)_M \quad (13)$$

These force ratios which appear in Eq. (11) through (13) are better known as dimensionless numbers, and they are given the titles shown in Eq. (14) through (16).

$$\text{Euler number:} \quad Eu = v \sqrt{\frac{\rho}{2\Delta P}} \quad (14)$$

$$\text{Reynolds number:} \quad Re = \frac{v\rho l}{\mu} \quad (15)$$

$$\text{Froude number:} \quad Fr = \frac{v}{\sqrt{lg}} \quad (16)$$

It should be noticed that two of Eq. (11) through (13) are independent, while the third is dependent. Therefore, dynamic similarity is attained if any two of these three equations are simultaneously satisfied.

However, it is almost impossible to have complete similarity between flow phenomena. In this study, as in most engineering problems, it is at times not necessary to satisfy all equations simultaneously. According to VENNARD (1966), some forces either (a) might not act, (b) might be of negligible magnitude, or (c) might oppose other forces in such a way that the effects of both are reduced. The predominant

fluid forces that act in most hydraulic structures, such as, flow into a drainage inlet, are gravity, inertia, and viscous forces; the effects of other forces, such as those due to surface tension and elasticity, can safely be neglected.

2.4 Froude Similitude

If one considers that flow at drainage inlets is primarily caused by gravitational forces, then the only criterion that needs to be satisfied is the Froude criterion, which can be stated as

$$Fr_p = Fr_m, \text{ or}$$

$$\left(\frac{v^2}{lg}\right)_p = \left(\frac{v^2}{lg}\right)_m \quad (17)$$

where v is the mean flow velocity in fps, g is the acceleration of gravity in ft/sec², and l is a characteristic length in ft.

Physical quantities for prototype and model can now be derived readily from the Froude relation. From Eq. (17) the prototype:model velocity ratio is obtained, such as

$$\frac{v_p}{v_m} = \left(\frac{l_p}{l_m}\right)^{1/2}, \quad (18)$$

and inasmuch as gravity cannot be modeled, one obtains:

$$\frac{v_p}{v_m} = \left(\frac{l_p}{l_m}\right)^{1/2} \quad (19)$$

With the scale ratio in the present study of $L_R = 2.0$, the velocity ratio becomes

$$\frac{v_p}{v_m} = 1.41 \quad (19a)$$

Furthermore, one can learn the flow rate in the prototype provided both the flow rate in the model and the prototype:model scale ratio are known. The discharge, Q , is given by the continuity equation; and with the knowledge of Eq. (2) and (19) one obtains:

$$\frac{Q_p}{Q_m} = \frac{A_p}{A_m} \cdot \frac{v_p}{v_m} = (L_R)^2 (L_R)^{1/2} = L_R^{5/2}, \quad (20)$$

where Q_p and Q_m denote the discharge in the prototype and in the model, respectively. With $L_R = 2.0$ in this study, Eq. (20) becomes

$$\frac{Q_p}{Q_m} = 5.66 \quad (20a)$$

Other characteristics of flow, such as area, volume, and time, can be readily obtained in a similar way. All of these ratios for a gravity or Froude model are shown in Table 2.1.

2.5 Manning Similitude

Although gravitational forces are very important in this problem, the effect of channel roughness should be investigated. In fact, the degree of roughness of the channel not only determines the

			Froude Similitude	Lehigh Univ. Scale	Manning Similitude	Lehigh Univ. Scale*
Physical Properties	Length	$\frac{l_p}{l_m}$	$\frac{l_p}{l_m}$	2.0	$\frac{l_p}{l_m}$	2.0
	Area	$\frac{A_p}{A_m}$	$\left(\frac{l_p}{l_m}\right)^2$	4.0	$\left(\frac{l_p}{l_m}\right)^2$	4.0
	Volume	$\frac{V_p}{V_m}$	$\left(\frac{l_p}{l_m}\right)^3$	8.0	$\left(\frac{l_p}{l_m}\right)^3$	8.0
Kinematic Properties	Time	$\frac{\tau_p}{\tau_m}$	$\left(\frac{l_p}{l_m}\right)^{1/2}$	1.41	$\left(\frac{l_p}{l_m}\right)^{1/3} \frac{n_p}{n_m}$	1.47
	Velocity	$\frac{v_p}{v_m}$	$\left(\frac{l_p}{l_m}\right)^{1/2}$	1.41	$\left(\frac{l_p}{l_m}\right)^{2/3} \frac{n_m}{n_p}$	1.36
	Discharge	$\frac{Q_p}{Q_m}$	$\left(\frac{l_p}{l_m}\right)^{5/2}$	5.66	$\left(\frac{l_p}{l_m}\right)^{8/3} \frac{n_m}{n_p}$	5.45

* $n_m = 0.012$, $n_p = 0.014$ (see Table 2.2)

Table 2.1: Model Scale for Froude Similitude and Manning Similitude

types of channel flow, but also affects the efficiency of the drainage inlet. Hence, it is desirable to consider both the forces of gravity and of friction or channel roughness. In order to do so, both the Froude model law and the Reynolds model law must be considered simultaneously. But it is impossible to satisfy both laws if the same fluid is to be used in both model and prototype. Other means of correlating prototype and model properties must be adopted.

An empirical relationship, such as the Manning formula, may be used as a friction criterion. The Manning formula is given as:

$$v = \frac{1.49 R_h^{2/3} S^{1/2}}{n} \quad (21)$$

where v is the mean velocity in fps, R_h is the hydraulic radius in ft and is equal to the cross-sectional area of water normal to the direction of flow divided by the wetted perimeter, n is the Manning coefficient of roughness, and S is the slope of energy grade line. If the flow is uniform, i.e., if a constant depth along the channel exists, then the slope of energy grade line and the slope of the water surface will be the same.

The friction criterion requires:

$$\left(\frac{R_h^{2/3} S^{1/2}}{v n} \right)_p = \left(\frac{R_h^{2/3} S^{1/2}}{v n} \right)_m \quad (22)$$

Inasmuch as the model is not distorted, i.e., $S_p = S_m$, and if the hydraulic radius, R_h , is replaced by a suitable dimension, L , one obtains:

$$\left(\frac{L^{2/3}}{v n}\right)_p = \left(\frac{L^{2/3}}{v n}\right)_m \quad (23)$$

Because the discharge relationship between prototype and model is of prime interest, Eq. (23) can be rearranged to

$$\frac{Q_p}{Q_m} = \left(\frac{L_p}{L_m}\right)^{5/3} \frac{n_m}{n_p} \quad (24)$$

This relationship and other flow characteristics for Manning similitude are shown in Table 2.1.

In order to evaluate Eq. (24), the roughnesses of the prototype and of the model, n_p and n_m , must be known. The Manning coefficient for the pavement was given by the Pennsylvania Department of Transportation as $n = 0.014$, which was in good agreement with the roughness cited in the literature, see CHOW (1959) and GRAF (1971). Plywood of 3/4-inch thickness has been used in the model in order to simulate the paved surface of the prototype. The Manning coefficient of plywood had been determined from flume tests at Lehigh University and was found to be $n = 0.012$. This value is in close agreement with that as given by CHOW (1959). It has been decided that a value of $n_p = 0.014$ and $n_m = 0.012$ will be used. The Manning roughness study is summarized in Table 2.2.

Introducing the knowledge of the Manning's value ratio $n_p/n_m = 0.014/0.012$ and the length ratio of $L_R = 2.0$, Eq. (24) then becomes

$$\frac{Q_p}{Q_m} = 5.45 \quad (24a)$$

n_{model} Plywood	$n_{\text{prototype}}$ Concrete
$n_m = 0.010$ to 0.014 (CHOW (1959))	$n_p = 0.011$ to 0.015 (CHOW (1959))
$n_m = 0.012$ (Lehigh Univ.)	$n_p = 0.014$ (used by PennDOT)
$n_m = 0.012$ (used in this study)	$n_p = 0.014$ (used in this study)

Table 2.2: Manning Roughness Coefficients

The application of the Manning formula requires turbulent flow both in the model and in the prototype. Almost all open-channel flow found in nature is turbulent, whereas flow occurring in a simulating model might very well not be turbulent. In order to ensure that turbulent flow does exist in the model, one should operate the model in such a way that a high Reynolds number, Re , is obtained.

In performing experiments in the model, it is then necessary to ascertain that turbulent flow does exist in it. The Reynolds number ratio from Eq. (15) is given as:

$$\frac{(Re)_p}{(Re)_m} = \frac{(vL)_p}{(vL)_m} \quad (25)$$

By substituting Eq. (23) into Eq. (25), one obtains

$$\frac{(Re)_p}{(Re)_m} = 2.72 \quad (25a)$$

A preliminary test was performed in the model, from which it was determined that turbulent flow does exist in the model.

2.6 Concluding Remarks

From observation of Table 2.1, the adoption of either one of the two similitudes - the Froude (gravity) and the Manning (roughness) similitudes - is a matter of choice. Gravity forces are more important, and Froude similitude has been selected for evaluating the results of this model.

3. EXPERIMENTAL INVESTIGATION

3.1 Inlets

Six different inlets are currently being installed along highways in Pennsylvania: these inlets are designated standards of the Pennsylvania Department of Transportation. They are (1) Type 4-Ft Special, (2) Type 6-Ft Special, (3) Type J, (4) Type H, (5) Type 4-Ft, and (6) Type 6-Ft. These inlets together with their specifications are summarized in Table 3.1. Each inlet differs from the other owing to the differences in installation as well as to the geometry of grate openings. However, Type 4-Ft Inlet and Type 4-Ft Special Inlet have the same grate openings; as is true of both Type 6-Ft Inlet and Type 6-Ft Special Inlet also.

All inlet gratings used in this study were made of wood. The first three inlets of Table 3.1 are installed on paved surfaces, whereas the last three are installed on channels that are usually covered with vegetation, specifically grass. Information pertaining to the two different surface roughnesses is shown in Table 2.2 and in Section 2.5. As a matter of convenience, it was decided that all those inlets installed on paved surfaces were to be tested first; Table 3.2 lists various channel conditions under which the first three inlets were to be tested.

3.1.1 Type 4-Ft Special and Type 6-Ft Special Inlets

Figures 3.1(a) and 3.1(b) show the geometry of the gratings for the Type 4-Ft Special Inlet and Type 6-Ft Special Inlet, respectively. The wooden frames of these inlet gratings were $2\frac{1}{2}$ -inches

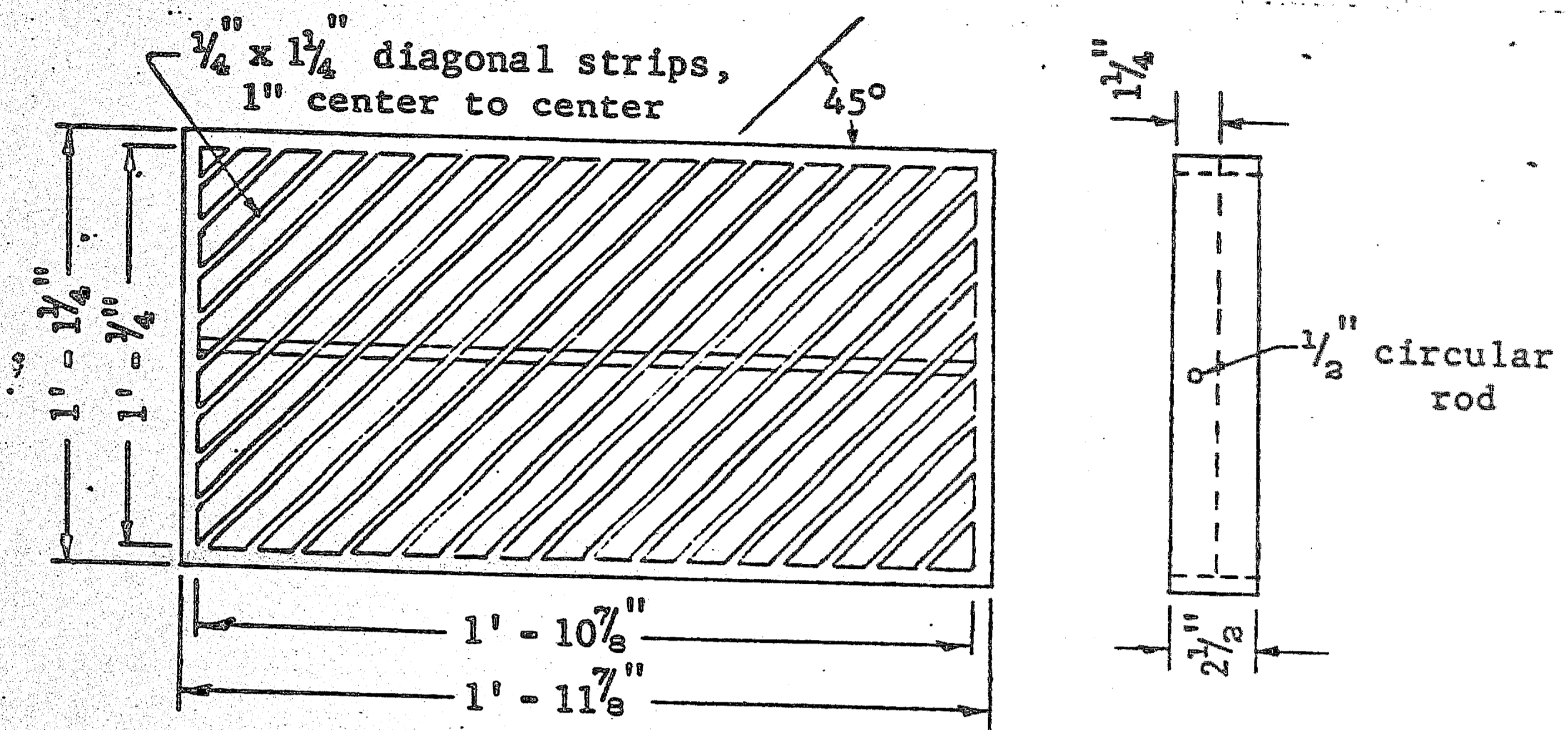

(a) Type 4-Ft Special Inlet

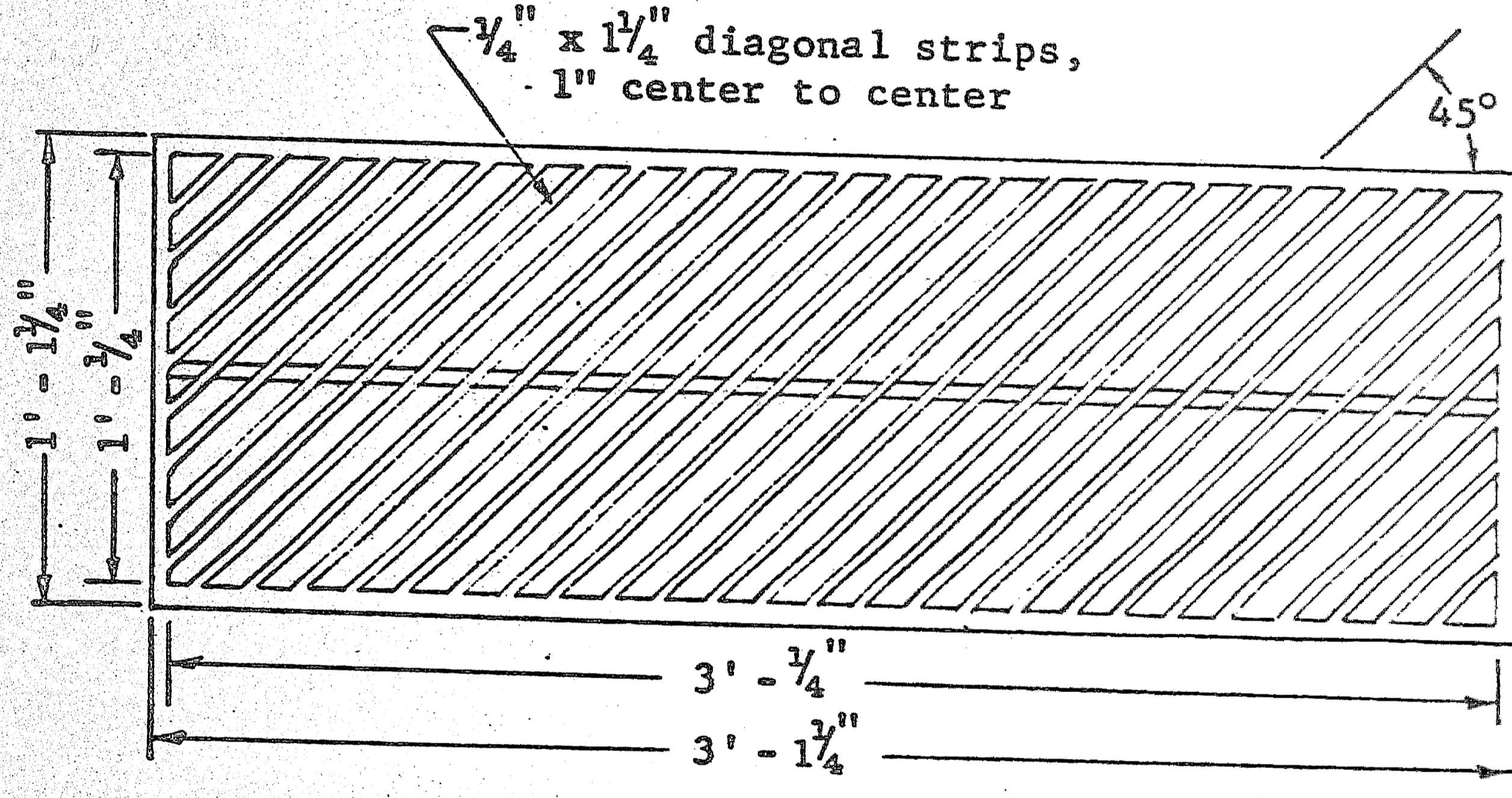

(b) Type 6-Ft Special Inlet

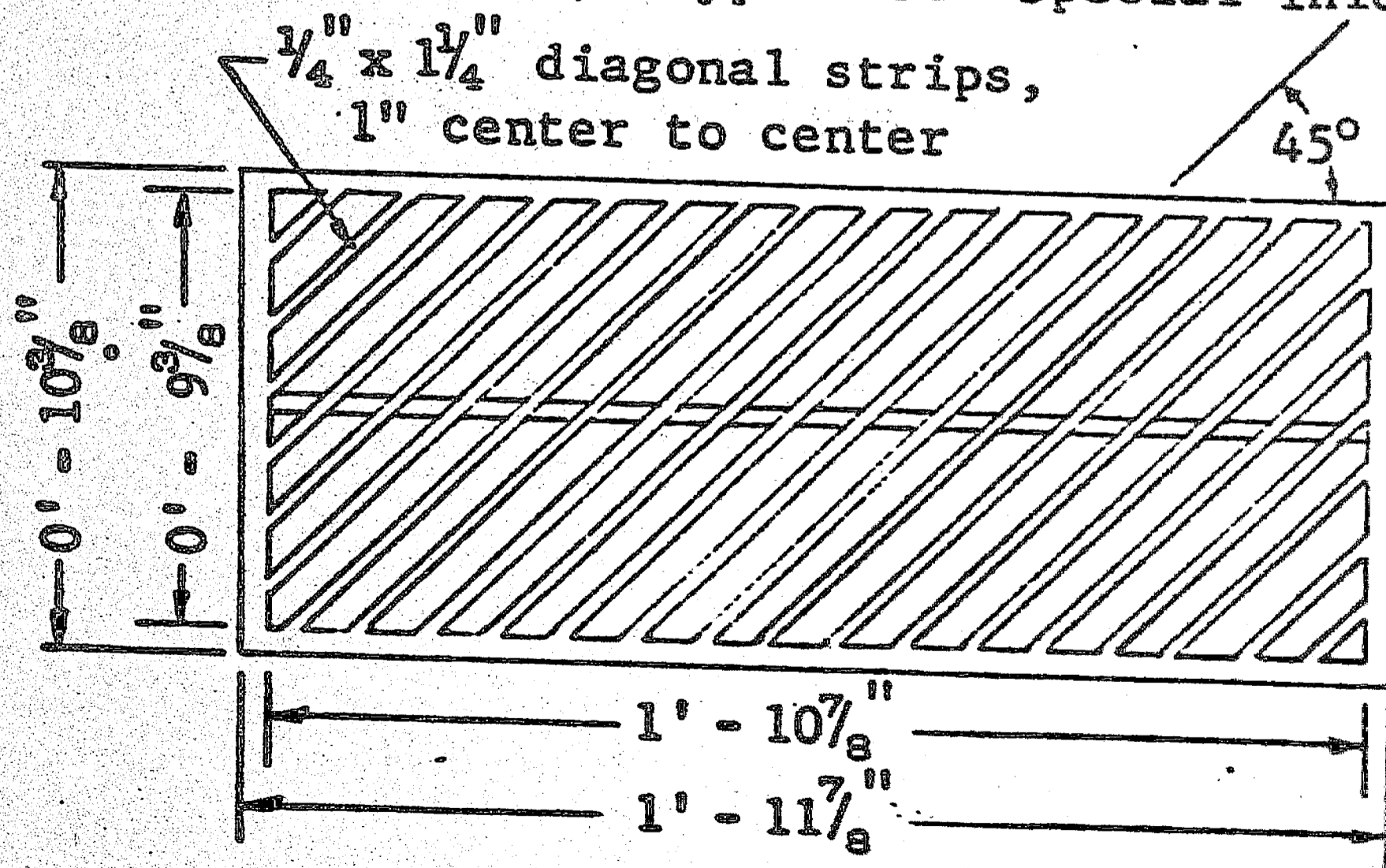

(c) Type J Inlet

NOTE: All gratings are of the same height.

Fig. 3.1 Model Inlet Grates

Inlet	Swale	Back Slope	Origin*
Type 4-Ft Special	Paved Area	Paved Area	(a)
Type 6-Ft Special	Paved Area	Paved Area	(a)
Type J	Paved Area	Paved Area	(b)
Type H	Grassed Area	Grassed Area	(c)
Type 4-Ft	Grassed Area	Grassed Area	(a)
Type 6-Ft	Grassed Area	Grassed Area	(a)

* Standard Drawings, Pennsylvania Department of Transportation.

(a) Standard Drawing: S.I. 4&6, Rev. Nov. 1, 1961.

(b) Standard Drawing: Misc. Inlets, Type H and Type J Inlets, Approved May 8, 1968.
SD-13, Type B Divisor, Approved May 13, 1966.

(c) Standard Drawing: Misc. Inlets, Type H and Type J Inlets, Approved May 8, 1968.

Grating: (1) Standard Drawing: Misc. Inlets-Supplemental Sheet A.
(2) Longitudinal Bars, at 3-inch centers, suggested design.
(3) Diagonal Bars, at 3-inch centers, suggested design.

Table 3.1 Standard Inlets

deep by the model scale, rather than $1\frac{1}{2}$ inches as required for the purpose of rigidity. This change in depth of frames was considered to have no effect on water flowing through the gratings. Figure 3.2 shows the installation of the 4-Ft Special Inlet and the 6-Ft Special Inlet. The surface of the grating was flush with the surface of the plywood which simulated the pavement. Plywood of $\frac{3}{4}$ -inch thickness and 8 inches in height was used to represent the curb that had a slope of 1/8:1. The hood which connected the curb opening and the vertical wall was made of 20-gauge galvanized steel.

Direction of Flow

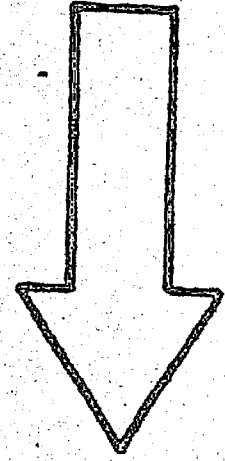

Inlet Grate

Swale

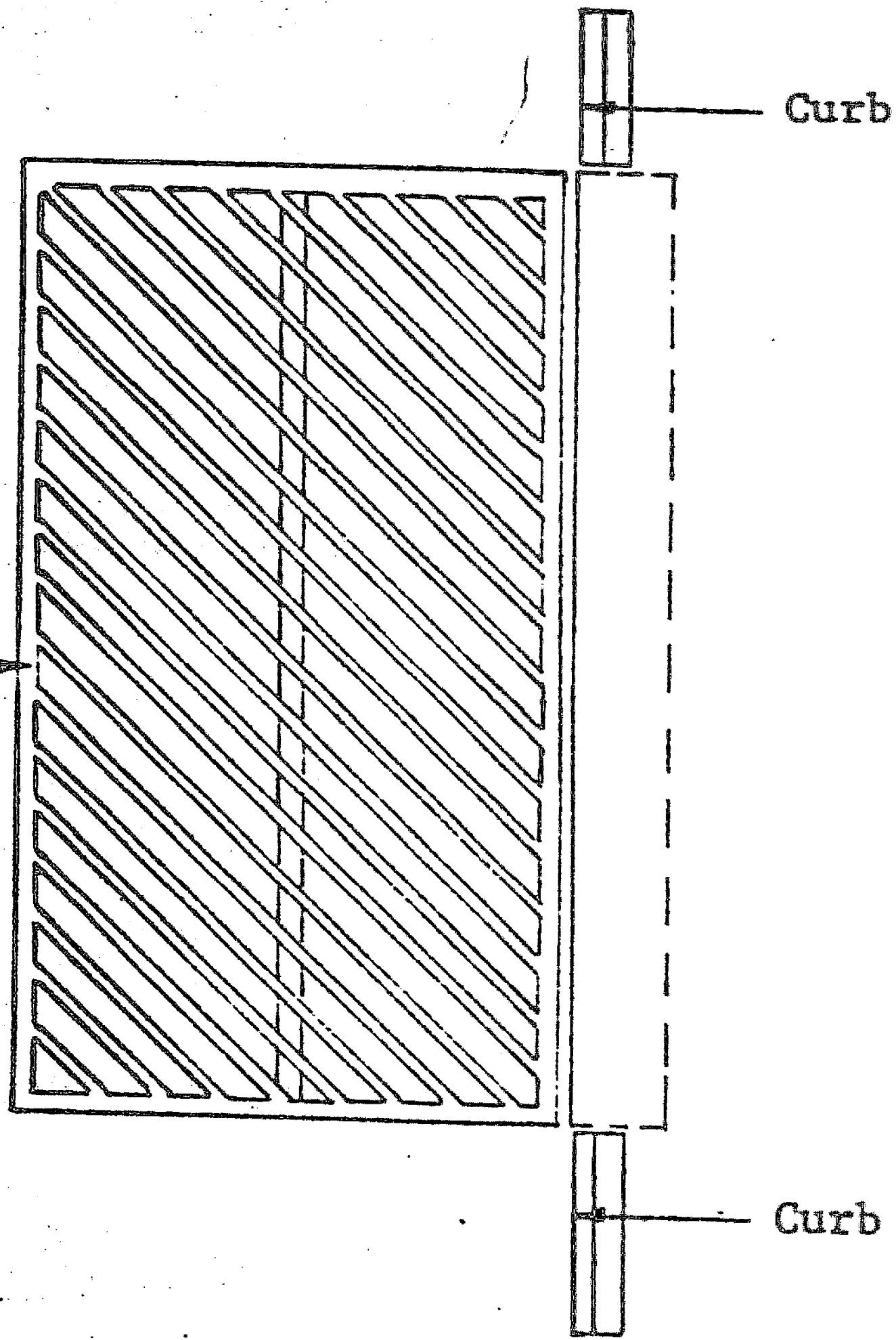

(a) Plan View

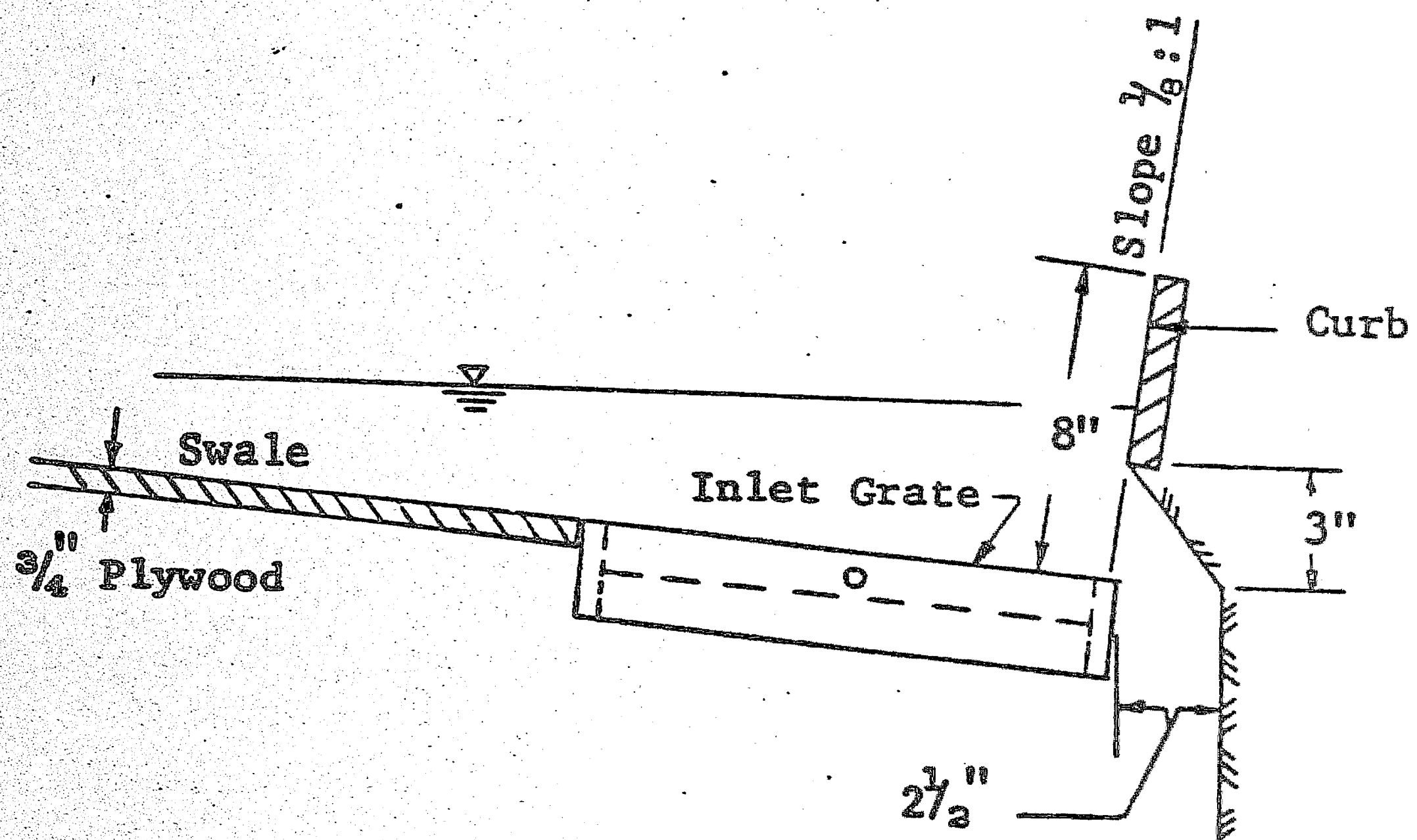

(b) Elevation View

Fig. 3.2 Installation for Type 4-Ft. Special Inlet and Type 6-Ft. Special Inlet

Inlet	Swale	Back Slope	Longitudinal Slope
Type 4-Ft Special	48:1,24:1, 16:1,12:1	1/8:1	0.5% , 2%, 4%, 8%
Type 6-Ft Special	48:1,24:1, 16:1,12:1	1/8:1	0.5% , 2%, 4%, 8%
Type J	48:1,24:1, 16:1,12:1	3:1	0.5% , 2%, 4%, 8%

Table 3.2 Order of Testing

3.1.2 Type J Inlet

Figure 3.1(c) shows the geometry of the grating for the Type J Inlet, and Fig. 3.3 shows its installation. The grating was flush with the plywood which simulated the pavement. The dimensions of the concrete divisor were taken from 'Type B Divisor' as appearing in the Pennsylvania Department of Transportation Standard Drawing: Concrete Mountable Curbs, Type A and B. Inasmuch as the water depth in the channel of the model did not exceed the height of the divisor at maximum channel discharge, only the half slope of the divisor adjacent to the flow was installed. The entire divisor was made of 20-gauge galvanized steel. The surface of the divisor was kept at a slope of 3:1 regardless of the swale slope. No scoring was made on the divisor because lines of scoring are no longer made on any divisor used on highways. The vertical wall along the inlet grating was 6 inches high and was made of 1/8-inch steel plate.

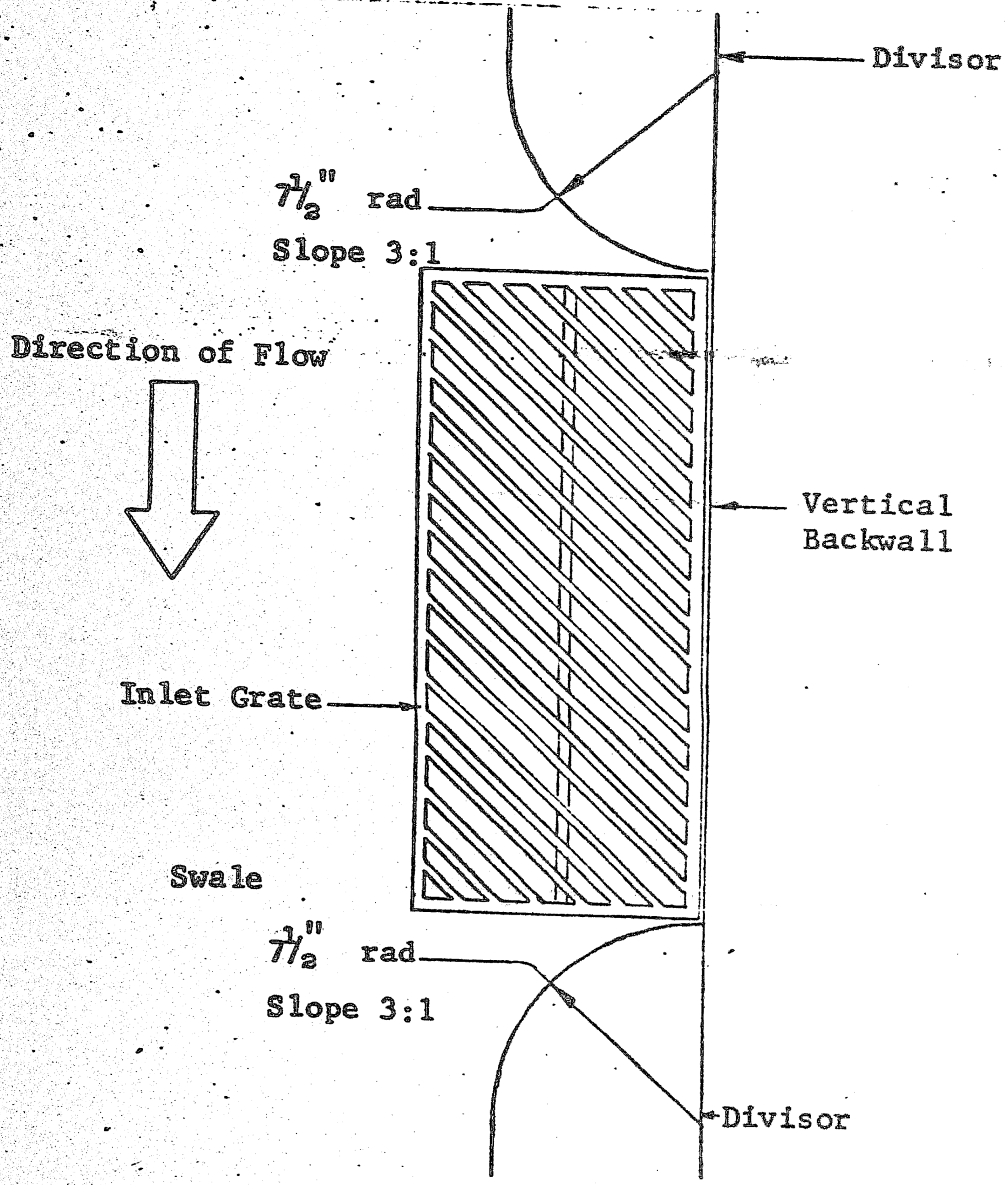

(a) Plan View

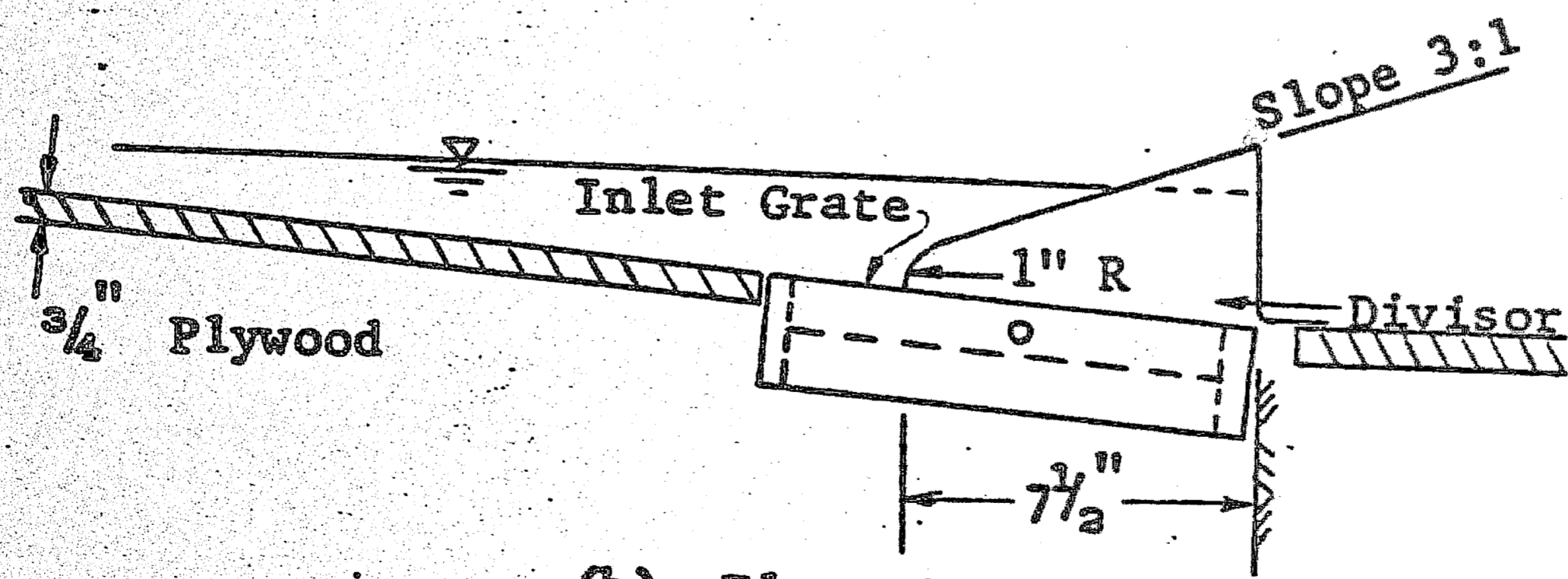

(b) Elevation View

Fig. 3.3 Installation for Type J Inlet

3.2 Laboratory Equipment

3.2.1 General Requirements

A full-size inlet grating was considered ideal in performing the experiments. However, as mentioned in Section 2.1, this could not be attained owing to the existing facilities and to the maximal discharge available in the laboratory. Hence, a prototype:model ratio of 2:1 was selected.

In order to obtain uniform flow in the channel upstream from an inlet, one would require a relatively long channel with a minimal amount of channel distortion. Guide vanes and baffles might be used in order to improve the upstream condition.

The frame supporting a model should be rigid. On the other hand, the model itself must be made versatile, because the experiments to be performed must involve different longitudinal slopes, swale slopes, and back slopes. The mechanism used to change these slopes should be simple and rugged. The model itself should be fabricated so that the change of inlet gratings would require a minimum of modification.

The surface roughness of the channel should bear a close resemblance to that of the pavement as used by the Pennsylvania Department of Transportation. The Manning coefficients for the model pavement and for the prototype pavement should be as similar as possible. The Manning coefficient of the material used in the model channel would have to be determined in a testing flume (see Section 2).

Inasmuch as the paramount objective of the study would be to determine the efficiencies of different inlets under a variety of conditions, efforts should be made to ensure that absolutely no leakage of water occur in the entire system and that measurements of flow rate be as accurate as possible.

3.2.2 Apparatus

A schematic diagram of the testing arrangement is shown in Fig. 3.4. Two pumps (B) raise water from the main sump (A) into the pressure tank (D). The two pumps can be operated either in parallel or in series by adjusting the three valves (C).

Each pump is driven by a Westinghouse 9B Type HF Induction Motor equipped with a rheostatic control. One motor had a rating of 40 Hp with a maximal speed of 1740 rpm; the other motor had a rating of 35 Hp with a maximal speed of 1720 rpm. The system operates on 220 volts AC. During a test both motors were adjusted to a rate of discharge that was fairly constant over a period of time.

Each pump is a single-stage, double-suction, centrifugal pump, Type I of DeLaval Manufacture. One pump had a 10-inch suction line and an 8-inch discharge line, whereas the other pump had an 8-inch suction line and a 6-inch discharge line.

The circular pressure tank (D) is $5\frac{1}{2}$ feet in diameter and 34 feet high. The rate of discharge delivered to the manifold discharge pipe (M) in the head tank (N) was obtained by opening the supply valve (E). The rate of inflow was measured by means of a

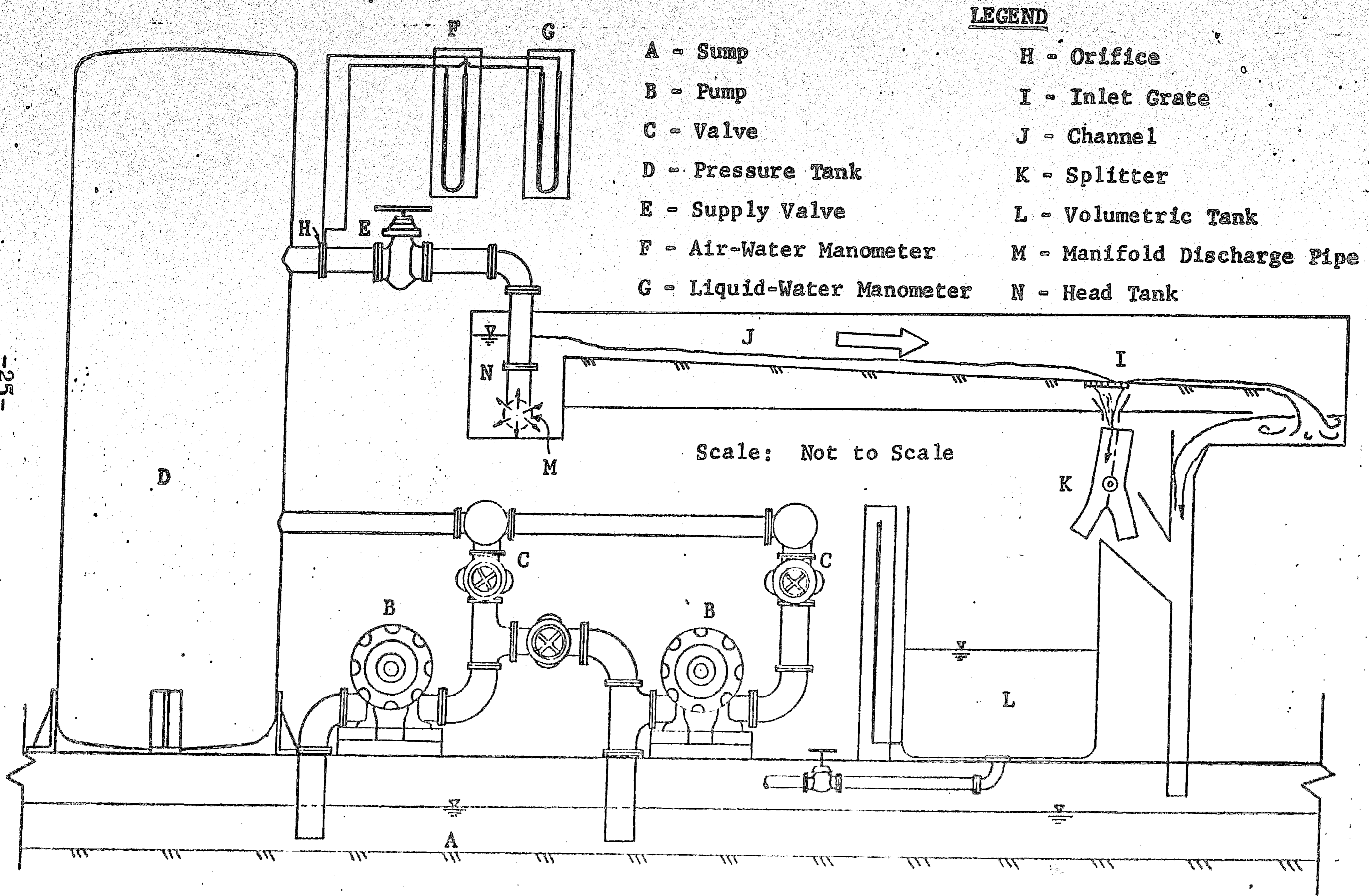

Fig. 3.4 Schematic Diagram

4-inch orifice (H) placed upstream from the supply valve in a 12-inch pipe, using either an air-water manometer (F) for a discharge of $Q \leq 0.5$ cfs or by a liquid-water manometer (G) for a discharge of $Q > 0.5$ cfs. The manometer liquid had a specific gravity of 2.95. The 4-inch orifice had been calibrated previously with the resulting volumetric expression given as:

$$Q = 0.42 H^{3/2}, \quad (26)$$

where Q is the flow rate of water in cubic feet per second, H is the pressure-head difference across the orifice in feet of water. Equation (26) was found to be correct when the orifice was recalibrated once again after some inlets had been tested.

As soon as the water was delivered into the head tank (N), it flowed through the channel (J) toward the inlet (I). The amount of water intercepted by the inlet was guided by the splitter (K) into the volumetric tank (L), if a measurement of rate of interception was taken, or was returned immediately into the main sump (A). The volumetric tank has a capacity of about 450 cubic feet. The amount of carryover flowed directly back into the sump (A).

The testing tank is rectangular in shape (see Fig. 3.5) and made of 1/4-inch steel plate framed by 3-inch by 3-inch angle iron. The bottom of the tank rests on beams placed transversely on 4-foot centers along the entire length of the testing tank. These beams are 2-inch by 7-inch channels. The testing tank has a total length of 33 feet, a width of 16 feet, and a depth of 3 feet. The head tank

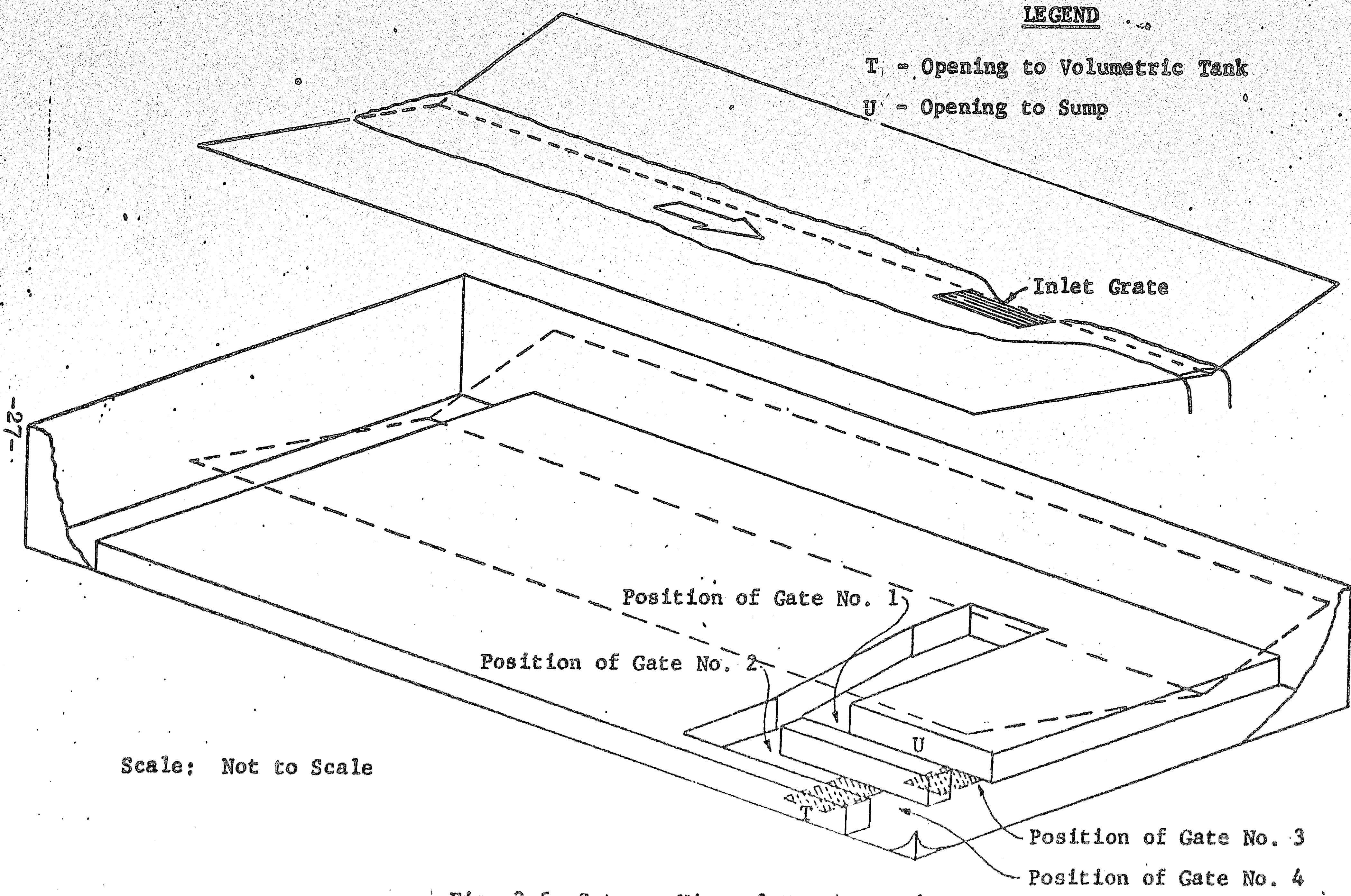

Fig. 3.5 Cutaway View of Testing Tank

containing the manifold discharge pipe is $2\frac{1}{2}$ feet long, 16 feet wide, and 4 feet deep.

Figure 3.5 is a cutaway view of the testing tank, and Fig. 3.6 shows the model placed in the testing tank. A conveyance channel (R), 1-foot deep with an average width of 2 feet, carries the water intercepted by the drainage inlet to an opening (T) connected to a volumetric tank. Another opening (U) near the downstream end of the testing tank is connected to the main sump.

During the process of calibrating the orifice, gates 1 and 3 were closed so that all water was drained into the volumetric tank through the opening (T) for measurement. To determine the amount of water intercepted by the inlet, gates 2 and 3 are opened while gates 1 and 4 are closed, whereas to determine the amount of carryover, gates 2 and 3 are closed and gates 1 and 4 are open.

3.2.3 Model Construction

Two steel frames were constructed to support the swale (O) and back slope (P) which form a triangular channel. One frame is 28 feet long and 12 feet wide, and the other is 28 feet by $3\frac{1}{2}$ feet. The former represents a portion of the swale of the roadway while the latter one represents a back slope. Both frames were made of S4 x 9.5 I-beams welded together. The welded joints were reinforced by clip angles in order to prevent any failure and to minimize deflection. The outer edges of the frames were made of S7 x 15.3 I-beams.

Both frames were covered with $\frac{3}{4}$ -inch outdoor plywood; each piece, measuring 4 by 8 feet, was treated with one coat of preservative

and with two coats of enamel paint. The joints of the plywood were covered with a 2-inch self-sticking transparent tape. The tape was then later covered with an enamel paint. Hinges were welded to the invert of the channel in order to prevent the two steel frames from separating and to provide freedom for the frames to rotate about the invert whenever different side slopes were desired.

The entire length of the invert rests on a W8 x 40 I-beam (S). This main supporting I-beam (see Fig. 3.6) is 28 feet in length and is hinged at its downstream end. By providing the proper height of support at the upstream end of the I-beam, any amount of longitudinal slope of the channel could be obtained to a maximal slope of 8.0%. Mid-point deflection of the I-beam was virtually eliminated by providing support at mid-span. The outer edge of the two frames is supported by four 3/4-inch threaded tension rods (Q). Hence, each side slope can be raised or lowered independently of the other. For structural reasons part of the main supporting I-beam is below the inlet gratings. Although this is not desirable because the beam could affect the flow pattern of the water coming into the inlet, efforts were made to ensure the vertical distance between the inlet opening and the beam be the maximal possible. Observation during testing showed that the I-beam was insignificant in affecting the flow.

Baffles and 30 aluminum guide vanes were installed at the upstream end of the channel so as to aid in developing uniform flow as the water approached the inlet. The guide vanes, each measuring 2 feet by 6 inches, were placed on 2-inch centers.

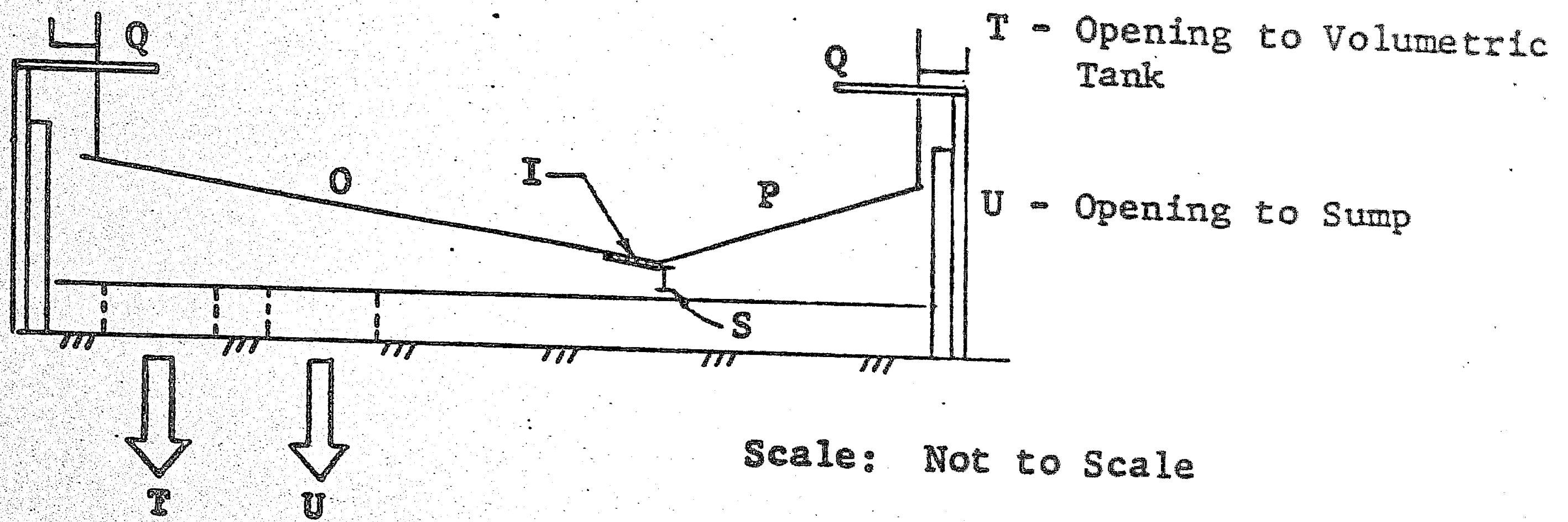
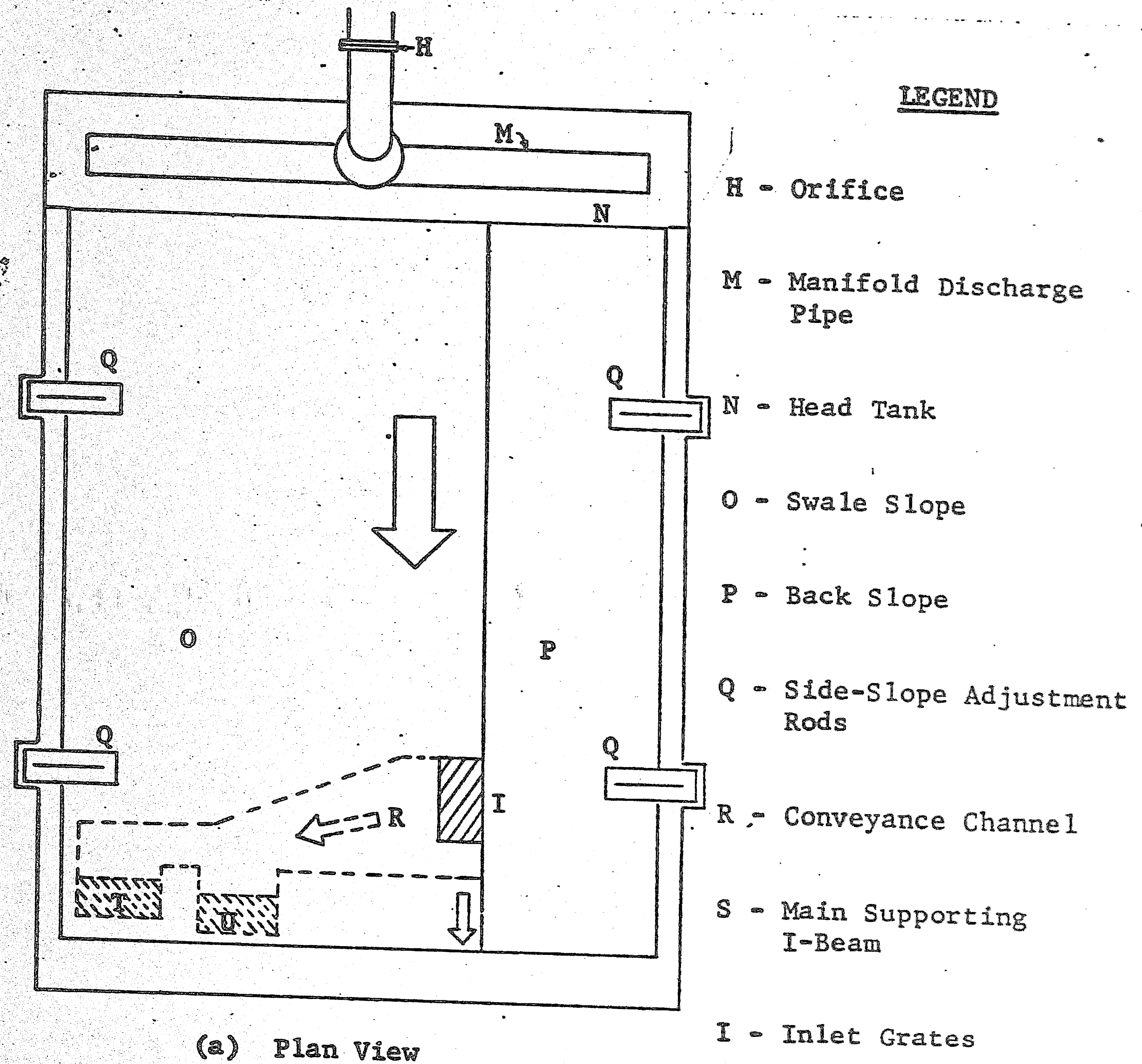

(b) Elevation View

Fig. 3.6 Testing Tank with Channel and Inlet Grate

3.3 Technique

3.3.1 Flow Measurements

As mentioned in Section 3.2.2, the flow rate into the head tank (N) was determined by reading the pressure-head difference across the 4-inch orifice indicated in the differential manometers (F) and (G). The orifice had previously been calibrated by a standard volumetric measuring method. The air-water manometer was used exclusively at discharge rates lower than 0.5 cfs because it yielded much more accurate results when the pressure drop across the orifice was small. The maximal discharge for the 4-inch orifice was 1.65 cfs. A higher discharge could be obtained by either (a) using a larger orifice, or (b) increasing the supply valve opening, or (c) increasing the speed of the motors.

The water intercepted by the drainage inlet is directed into the volumetric tank after properly positioning the four gates in the conveyance channel. This amount of water intercepted by the inlet can be obtained by recording the difference of the water level in the volumetric tank. The flow rate (Q_2) is the amount of water intercepted divided by the time interval involved. The carryover flow rate (Q_3) is the difference between the channel or supply flow rate (Q_1) and the intercepted flow rate (Q_2). The water in the volumetric tank is drained periodically into the main sump by opening the drainage valve.

3.3.2 Depth Measurements

A point gage graduated to 0.001 ft was used in all depth measurements. The gage is mounted on a small carriage that rolls

along a 3-inch by 5-inch aluminum rectangular channel which is 17 feet long, is placed 2 feet above the invert, and is at right angles to the invert of the channel. Both ends of the aluminum member are supported by a monorail system which permits the beam to travel freely above the invert of the channel. Such an arrangement permits a depth measurement to be made at any point in the channel. During a test measurements of depth were taken at stations that were 1 ft, 2 ft, and 3 ft upstream from the start of inlet gratings.

3.4 Procedure

Prior to a test, the particular inlet grating was installed according to PennDOT specifications. The channel configurations (longitudinal slope, swale slope, and back slope) were then adjusted and checked with the use of a surveyor's level.

Subsequently the supply valve (see Figure 3.4) was opened to a certain slow rate (Q_1) which was obtained by reading the pressure drop across the orifice from the manometers; equation (26) was used to calculate Q_1 .

A suitable time-interval (5 minutes was found to be usually sufficient) elapsed until steady-state condition was obtained in the channel. Subsequently the depth measurements were made. The amount of water intercepted by the inlet during one minute was guided by the splitter into the volumetric tank for determination of the intercepted flow rate, Q_2 . By subtracting the intercepted flow rate (Q_2) from the supply flow rate (Q_1), the carryover flow rate (Q_3) was obtained.

After all measurements corresponding to one flow rate were recorded, the incoming flow was slightly decreased by closing the supply valve, and the entire procedure was repeated. Usually 10 different flow rates sufficed to define the inlet efficiency curve. The experimental data are summarized in the Appendix.

4. RESULTS AND DISCUSSION

4.1 Experimental Results

All measurements made in this study are presented in the Appendix. They are also displayed in Figures 4.1 to 4.12 and summarized in Tables 4.1 to 4.3.

The schedule for the tests was arranged in such a way that a minimum of alteration and the least amount of time were required in order either to change inlet gratings or to alter the three slopes of the channel. A few tests were repeated owing either to inadequate data points or to unsatisfactory results.

The efficiency of an inlet, indicated as η , is defined as $(Q_2/Q_1) \times 100\%$, where Q_1 is the channel flow rate (discharge) in cfs, and Q_2 is the intercepted flow rate in cfs. The efficiency curves for the inlets are presented in Figures 4.1 to 4.12, inclusive. The channel flow rate, Q_1 , is plotted on the lower horizontal axis against the efficiency in percent on the vertical axis. The upper horizontal axis represents the prototype channel flow rate, Q_1 ; this quantity in relation to the model channel flow rate is obtained by using Eq. (20a).

Each figure shows the efficiencies of an inlet for one particular channel longitudinal slope and one back slope, but with four different swale slopes, namely, 12:1, 16:1, 24:1 and 48:1. The three dashes on a curve show that a water spread of 8 feet is reached on the swale in the prototype channel, or a spread of 4 feet on the swale in the model channel. The absence of the three dashes on a curve

indicates that the spread of 4 feet on the swale of the model channel was not obtainable.

4.2 Discussion of Measurements

4.2.1 Flow Measurements

The use of an orifice placed in a pipe to measure channel flow rate yielded accurate results. The range of channel flow rates was from 0.038 cfs to 1.65 cfs. Eq. (26) was used to calculate the channel flow rate after obtaining the pressure drop across the orifice. The equation was corroborated by recalibrating of the orifice, provided the motor of each pump was set to the same speed every time as that during orifice calibration.

In order to obtain an efficiency of 100 percent for an inlet placed under a certain condition, it was necessary to reduce the flow so that no water would by-pass the inlet. Such condition was usually obtained by actual observation at the downstream side of the channel. Since one drainage inlet (Type J) has fairly low efficiencies, particularly at a steep channel slope and a flat swale slope, it was at times difficult to adjust the flow so that 100 percent efficiency was obtained.

The intercepted flow rate was obtained by means of a volumetric measurement over a period of time, usually 60 seconds. It was found that such a time interval was adequate.

4.2.2 Depth Measurements

As mentioned in Section 3.2.2, all depth measurements were obtained by means of a point gage. Depths were measured at the invert

of the channel. Three depth readings for each channel flow rate were taken at stations that were 1 ft, 2 ft, and 3 ft horizontally upstream from the upper end of the inlet grating; the readings were recorded on data sheets in that order. If the slope of the channel were steep and the channel flow rate high, it was difficult to take any depth measurement accurately due to the fluctuation of the water surface about some mean point.

Guide vanes were used at the upstream end of the channel so as to aid in developing uniform flow (see Section 3.2.3). However, they could not completely eliminate some surface cross waves which might have affected the depth readings. It was found that baffles placed at the upstream portion of the channel were quite satisfactory in eliminating surface cross waves. The baffles were made of $\frac{1}{4}$ -inch galvanized hardware cloth that was deformed and then placed in layers so as to present in end view the configuration of 1-inch chicken wire, the layers being successively soldered together. At low flow rates over flat slope of the channel, such baffles was not essential.

4.3 Efficiencies of Inlets

The main purpose of this study is to determine experimentally the efficiencies of three highway drainage inlets used by the Pennsylvania Department of Transportation under various channel configurations and over a range of channel flow rates. Inasmuch as most standard inlets are constructed and installed differently, they will have different efficiencies when tested under the same condition. Obviously an inlet

having a larger opening will intercept more water than one having a smaller opening. Hence it is only reasonable to compare the performances of any particular inlet under certain different channel configurations.

By observation of the efficiency curves shown in Figures 4.1 through 4.12, a general conclusion can be made: for an inlet placed in a channel with fixed longitudinal and back slopes, its efficiency decreases as the steepness of the swale slope decreases for the same channel flow rate. The reason is that the spread of water on the swale slope is much smaller for a steep swale slope than for a flat swale slope. A channel with steep swale or back slope will guide the major portion of the flow towards the inlet, thus making for a higher efficiency of the inlet.

4.3.1 Efficiencies of Type J Inlet

Figures 4.1 through 4.4 show the efficiency curves for Type J Inlet. It can be noted that without a change in the channel configuration, the efficiency of an inlet drops as the channel flow rate increases. At low channel flow rates where the efficiencies are high, all curves drop drastically as the channel flow rates are increased; this is an area of steep curves. Upon increasing the channel flow rates, the steepness of these efficiency curves are reduced and they tend to be parallel to one another at high channel flow rates; this is an area of less steep curves.

The longitudinal slope of the channel also has a significant effect on the efficiency of the drainage inlet. If the longitudinal

slope of the channel is steep, a portion of the water approaching the inlet is not intercepted by the inlet, rather owing to its high inertia it actually flows along the top surface of the inlet grating, thus bypassing the inlet. In general channels with a $\frac{1}{2}\%$ longitudinal slope yield the highest efficiency for Type J Inlet.

The efficiency of Type J Inlets also depends upon the channel flow rate. Observations pertaining thereto are summarized in Table 4.1. In this table, columns 1 and 2 describe the configurations of the channel. Column 3 indicates the capacity ($Q_{2\ 100\%}$) of an inlet for an efficiency of 100%. Column 4 indicates the efficiency of an inlet for the channel flow rate of $1\frac{1}{2}$ times that of channel flow rate at an efficiency of 100%, that is, $1.5Q_{2\ 100\%}$. Generally speaking the efficiencies of the Type J Inlets are very low. Besides having a very low inlet capacity for an efficiency of 100%, the efficiency of the Type J Inlet drastically drops as low as 50% for an increase of the channel flow rate from $Q_{2\ 100\%}$ to $1.5Q_{2\ 100\%}$ for a longitudinal slope of 8%. This drop in efficiency is less pronounced for the longitudinal slopes of either $\frac{1}{2}\%$, 2% or 4%.

4.3.2 Efficiencies of 4-Ft Special Inlet and 6-Ft Special Inlet

Figures 4.5 through 4.8 show the efficiency curves of the 4-Ft Special Inlet, whereas Figures 4.9 through 4.12 show the efficiency curves of the 6-Ft Special Inlet. Type 6-Ft Special Inlets have usually higher efficiencies than the 4-Ft Special Inlets provided both are placed under the same channel condition and flow rate. However the difference in efficiencies between the two inlets is small.

All figures show almost an absence of area of steep curves as discussed in Section 4.3.1. However, it can be noticed that for the same channel condition curves corresponding to different swale slopes are parallel to one another, or tend to be so. Figures 4.5 through 4.8 show that for the Type 4-Ft Special Inlet in a channel with fixed longitudinal slope and back slope the change in efficiency:

1. Ranges from 2 to 10% upon changing the swale slope from 12:1 to 16:1;
2. Ranges from 5 to 18% upon changing the swale slope from 16:1 to 24:1;
3. Ranges from 12 to 20% upon changing the swale slope from 24:1 to 48:1.

Figures 4.9 through 4.12 show that for the Type 6-Ft Special Inlet in a channel with fixed longitudinal slope and back slope, the changes in efficiency:

1. Ranges from 4 to 10% upon changing the swale slope from 12:1 to 16:1;
2. Ranges from 4 to 18% upon changing the swale slope from 16:1 to 24:1;
3. Ranges from 12 to 20% upon changing the swale slope from 24:1 to 48:1.

° In general, channels having a longitudinal slope of either 2% or 4% yield much higher inlet efficiencies for both the 4-Ft Special Inlet and the 6-Ft Special Inlet than channel of a longitudinal slope of $\frac{1}{2}$ % and 8%.

Table 4.2 and Table 4.3 show the characteristics of the efficiency curves for the Type 4-Ft Special Inlet and for the Type 6-Ft Special Inlet, respectively. The Type 6-Ft Special Inlet always has a higher capacity at an efficiency of 100% (column 3 of each table). Generally the efficiency of each inlet remains fairly high, above 90%, with an increase in the channel flow rate from $Q_{2,100\%}$ to $1.5Q_{2,100\%}$ (see column 4 of each table). And this is true regardless of channel longitudinal slope.

Long. Slope	Swale Slope	$Q_2 @ \eta = 100%*$	$Q_2 + 0.5Q_2$
½%	12:1	0.120 cfs	$\eta = 88%$
	16:1	0.100 cfs	$\eta = 87%$
	24:1	0.084 cfs	$\eta = 84%$
	48:1	0.038 cfs	$\eta = 93%$
2%	12:1	0.100 cfs	$\eta = 80%$
	16:1	0.075 cfs	$\eta = 77%$
	24:1	0.053 cfs	$\eta = 85%$
	48:1	0.053 cfs	$\eta = 70%$
4%	12:1	0.084 cfs	$\eta = 82%$
	16:1	0.065 cfs	$\eta = 83%$
	24:1	0.065 cfs	$\eta = 77%$
	48:1	0.053 cfs	$\eta = 57%$
8%	12:1	0.236 cfs	$\eta = 50%$
	16:1	0.190 cfs	$\eta = 50%$
	24:1	0.100 cfs	$\eta = 51%$
	48:1	0.038 cfs	$\eta = 59%$

* η - Efficiency of inlet.

Q_2 - Capacity of model inlet for an inlet efficiency of 100%.

Table 4.1 Comparison of Efficiencies of Inlet--Type J Inlet

Long. Slope	Swale Slope	Q_2 @ $\eta = 100\%^*$	$Q_2 + 0.5Q_2$
½%	12:1	0.260 cfs	$\eta = 98\%$
	16:1	0.260 cfs	$\eta = 94\%$
	24:1	0.053 cfs	$\eta = 98\%$
	48:1	0.030 cfs	$\eta = 97\%$
2%	12:1	0.490 cfs	$\eta = 95\%$
	16:1	0.365 cfs	$\eta = 95\%$
	24:1	0.315 cfs	$\eta = 91\%$
	48:1	0.106 cfs	$\eta = 94\%$
4%	12:1	0.600 cfs	$\eta = 89\%$
	16:1	0.450 cfs	$\eta = 92\%$
	24:1	0.210 cfs	$\eta = 93\%$
	48:1	0.075 cfs	$\eta = 96\%$
8%	12:1	0.425 cfs	$\eta = 92\%$
	16:1	0.345 cfs	$\eta = 94\%$
	24:1	0.215 cfs	$\eta = 96\%$
	48:1	0.080 cfs	$\eta = 99\%$

* η - Efficiency of inlet.

Q_2 - Capacity of model inlet for an inlet efficiency of 100%.

Table 4.2 Comparison of Efficiencies of Inlet--4-Ft Special

Long. Slope	Swale Slope	Q_2 @ = 100% *	$Q_2 + 0.5Q_2$
½%	12:1	0.470 cfs	$\eta = 94\%$
	16:1	0.260 cfs	$\eta = 98\%$
	24:1	0.166 cfs	$\eta = 91\%$
	48:1	0.038 cfs	$\eta = 98\%$
2%	12:1	0.710 cfs	$\eta = 93\%$
	16:1	0.650 cfs	$\eta = 86\%$
	24:1	0.415 cfs	$\eta = 87\%$
	48:1	0.120 cfs	$\eta = 95\%$
4%	12:1	0.720 cfs	$\eta = 91\%$
	16:1	0.510 cfs	$\eta = 93\%$
	24:1	0.273 cfs	$\eta = 93\%$
	48:1	0.117 cfs	$\eta = 93\%$
8%	12:1	0.484 cfs	$\eta = 94\%$
	16:1	0.310 cfs	$\eta = 96\%$
	24:1	0.210 cfs	$\eta = 97\%$
	48:1	0.130 cfs	$\eta = 97\%$

* η - Efficiency of inlet.

Q_2 - Capacity of model inlet for an inlet efficiency of 100%.

Table 4.3 Comparison of Efficiencies of Inlet--6-Ft Special

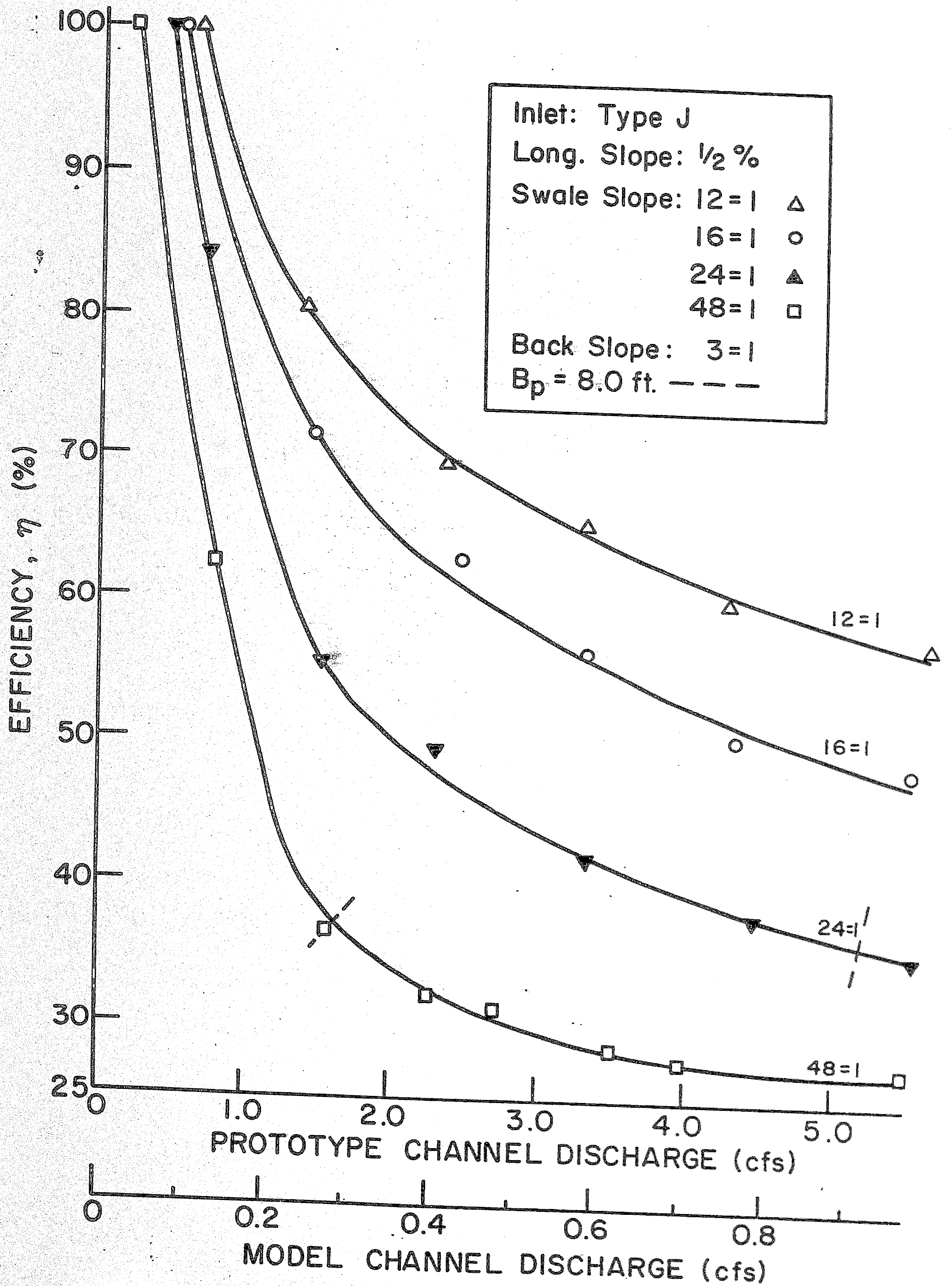

Fig. 4.1 Efficiency Curves; Type J Inlet (Long. Slope = $\frac{1}{2}\%$)

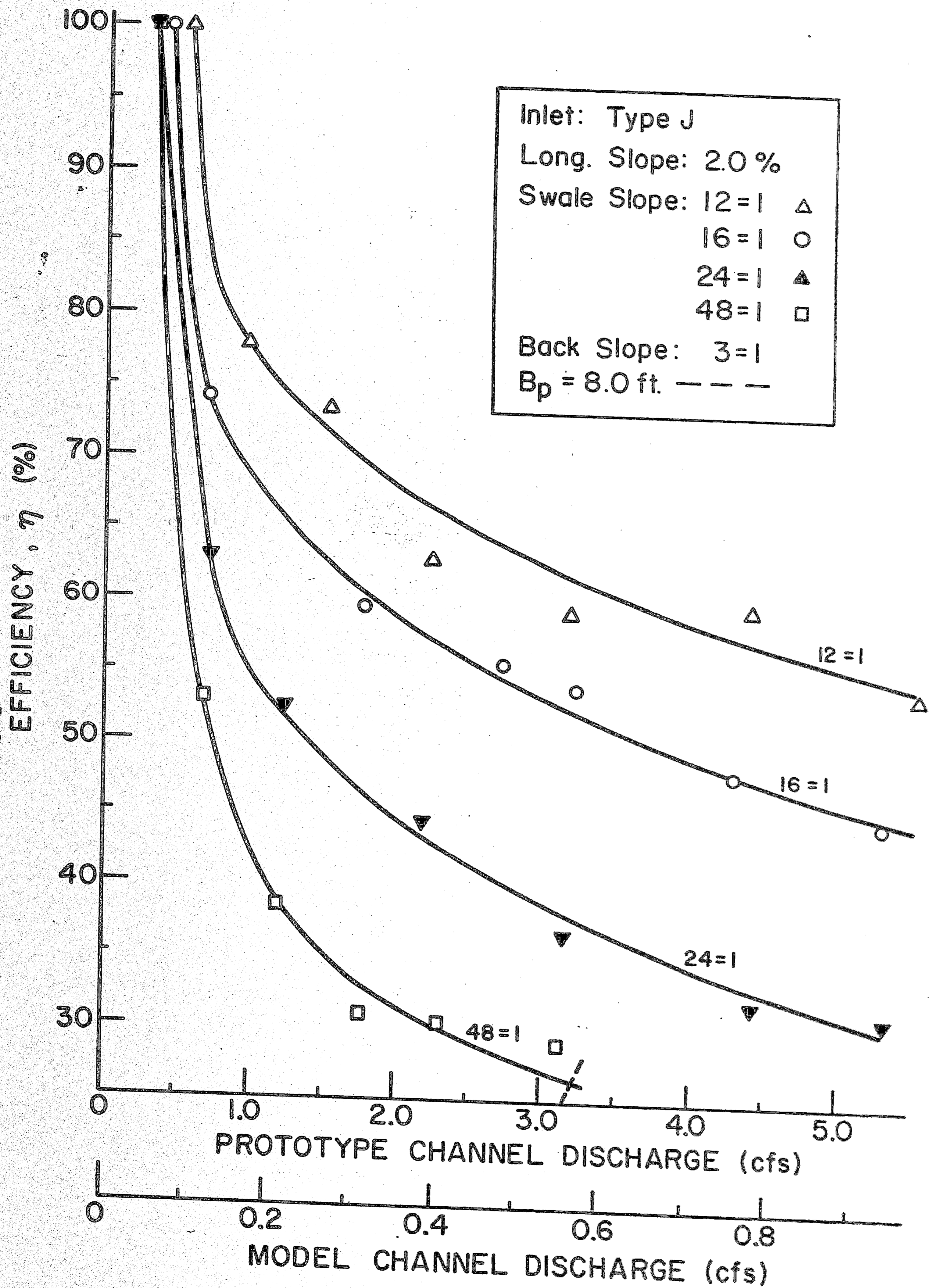

Fig. 4.2 Efficiency Curves; Type J Inlet (Long. Slope = 2%)

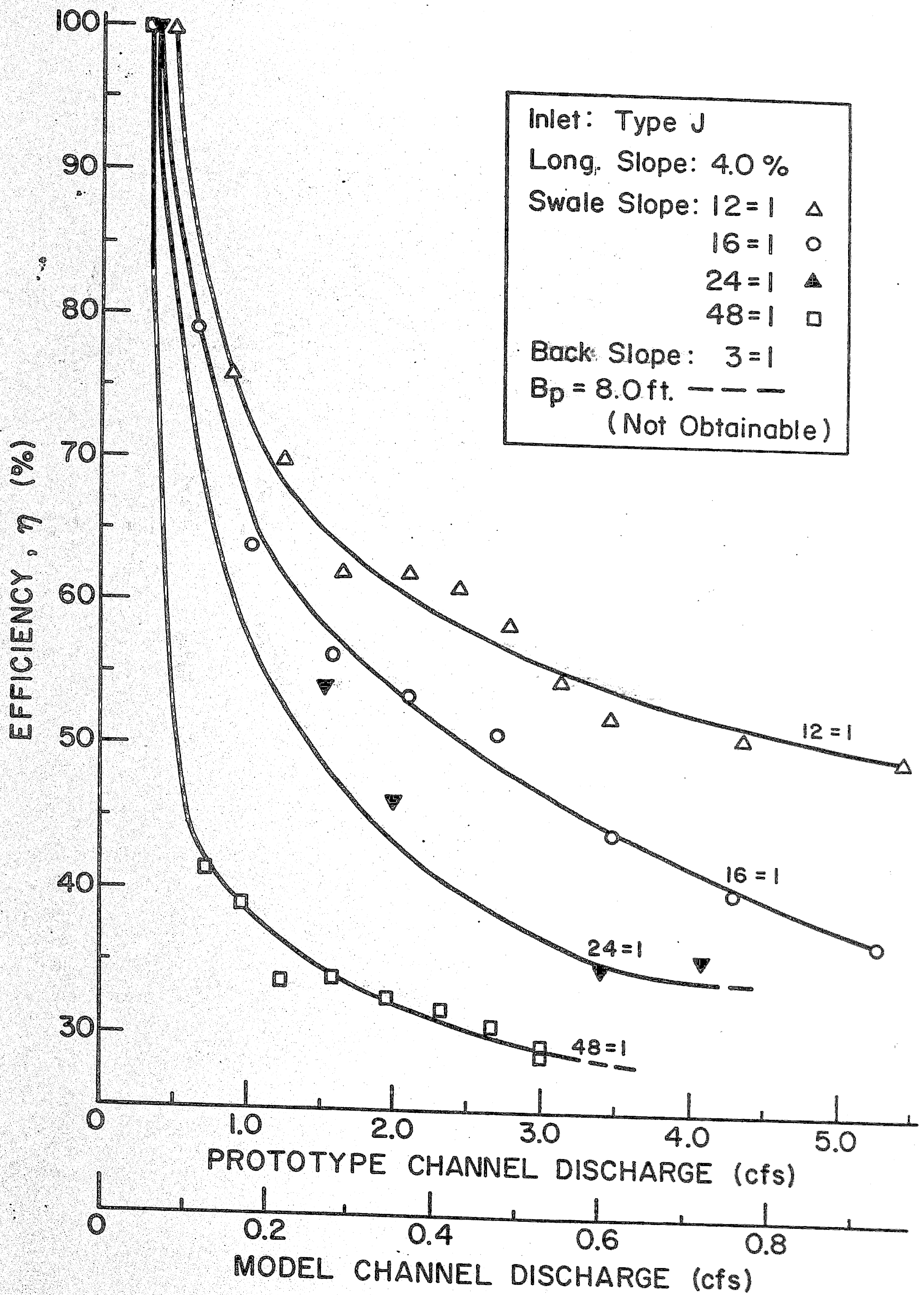

Fig. 4.3 Efficiency Curves; Type J Inlet (Long. Slope = 4%)

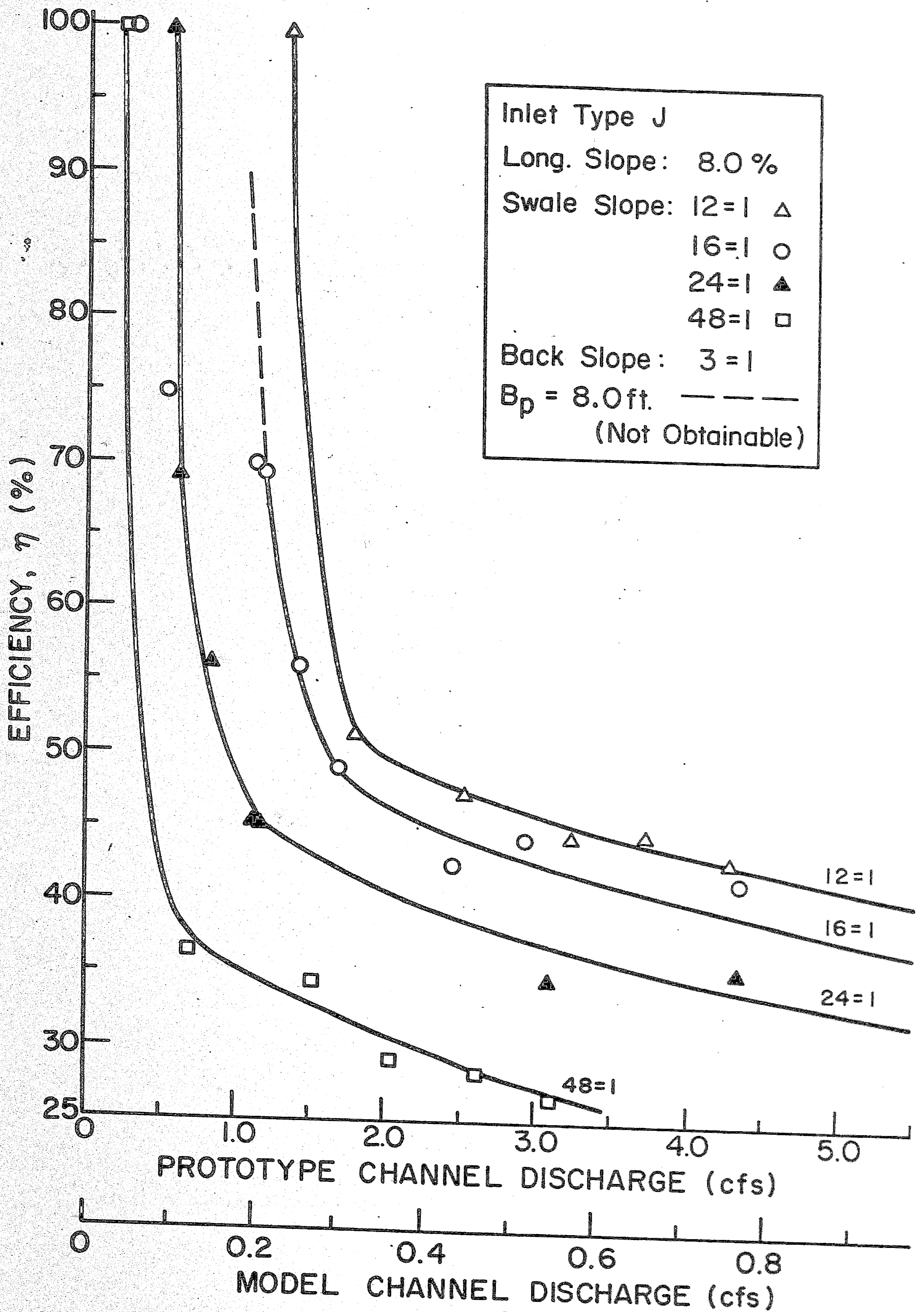

Fig. 4.4 Efficiency Curves; Type J Inlet (Long. Slope = 8%)

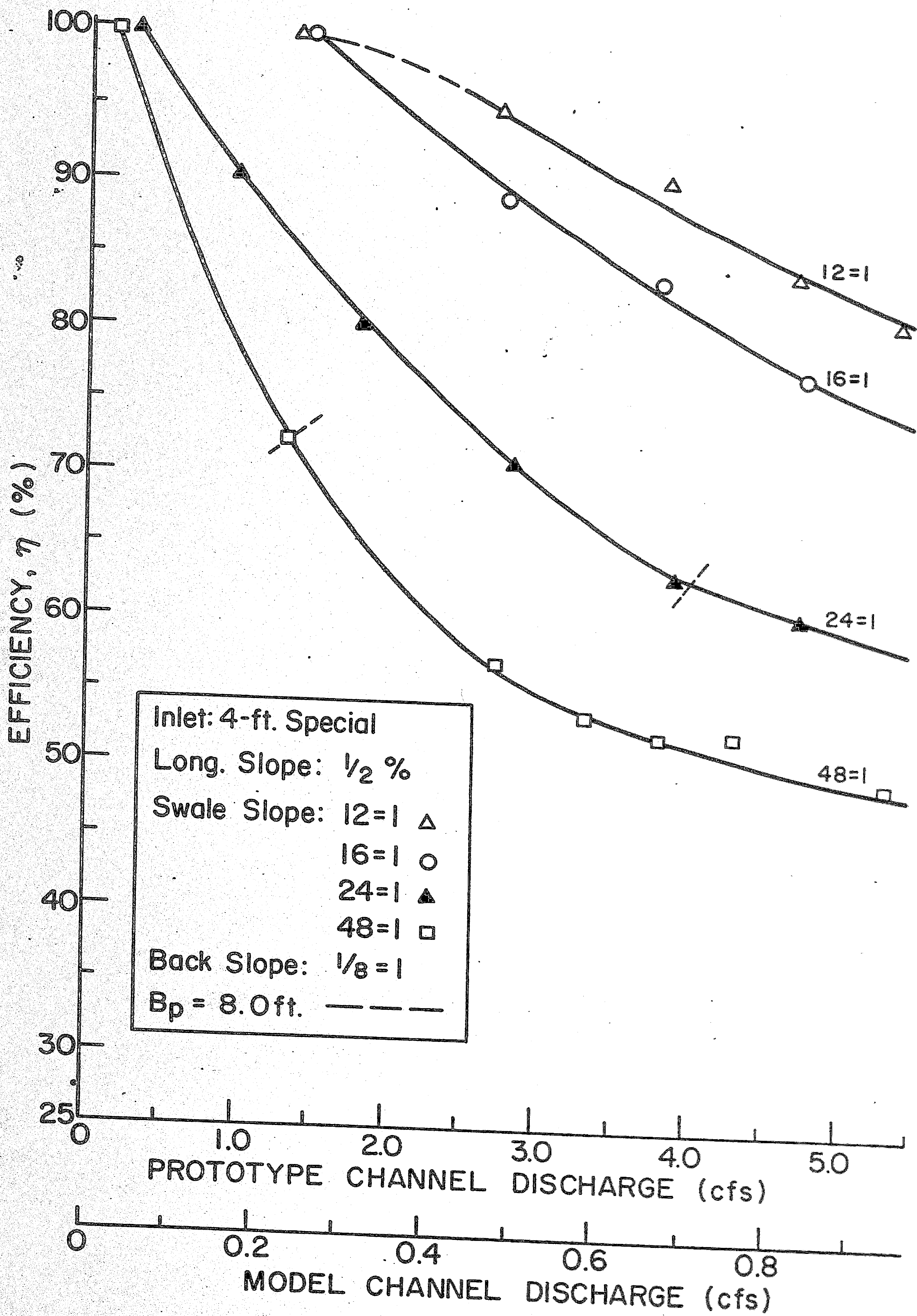

Fig. 4.5 Efficiency Curves; 4-Ft Special (Long. Slope = $\frac{1}{2}\%$)

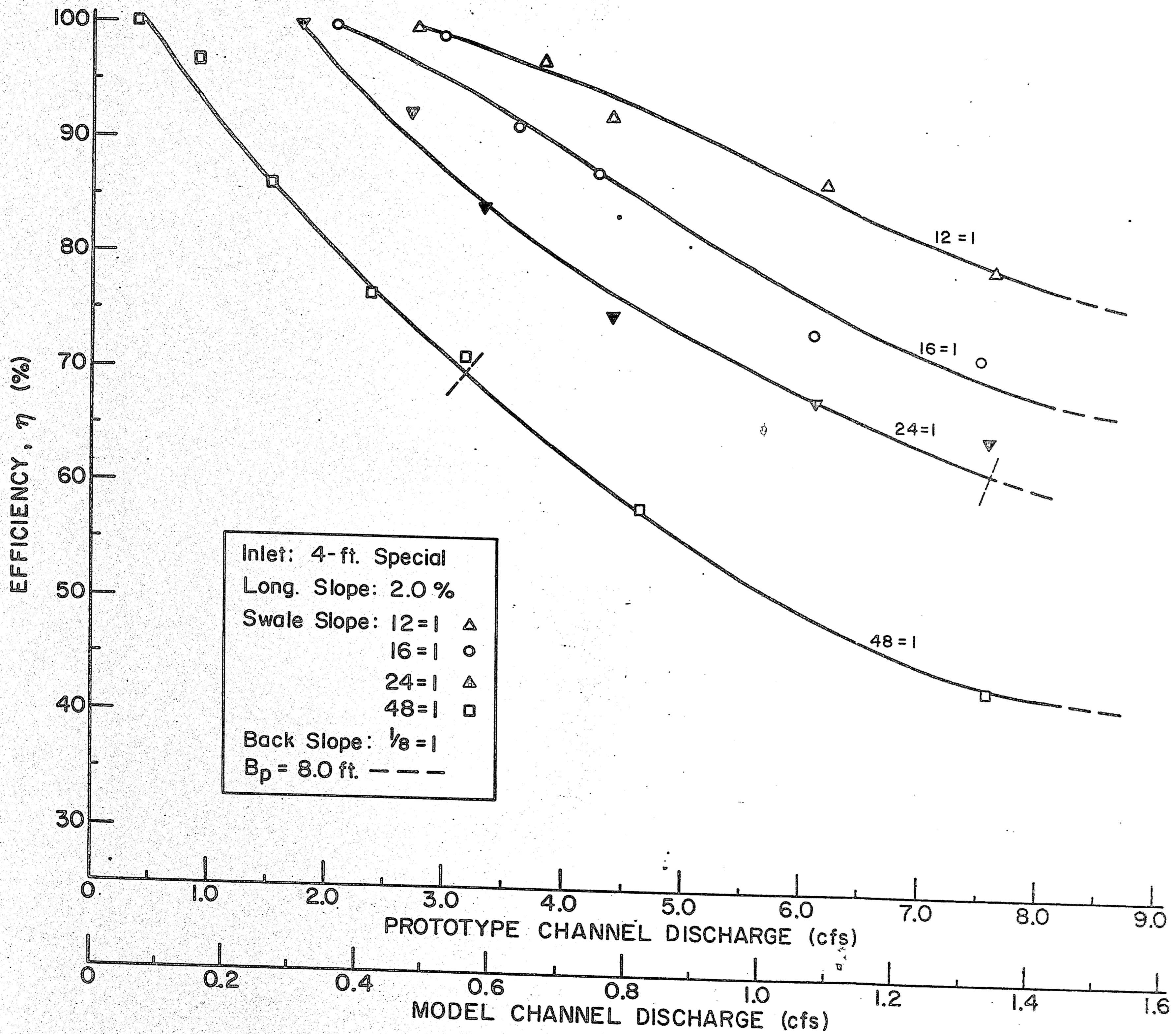

Fig. 4.6 Efficiency Curves; 4-Ft Special (Long. Slope = 2%)

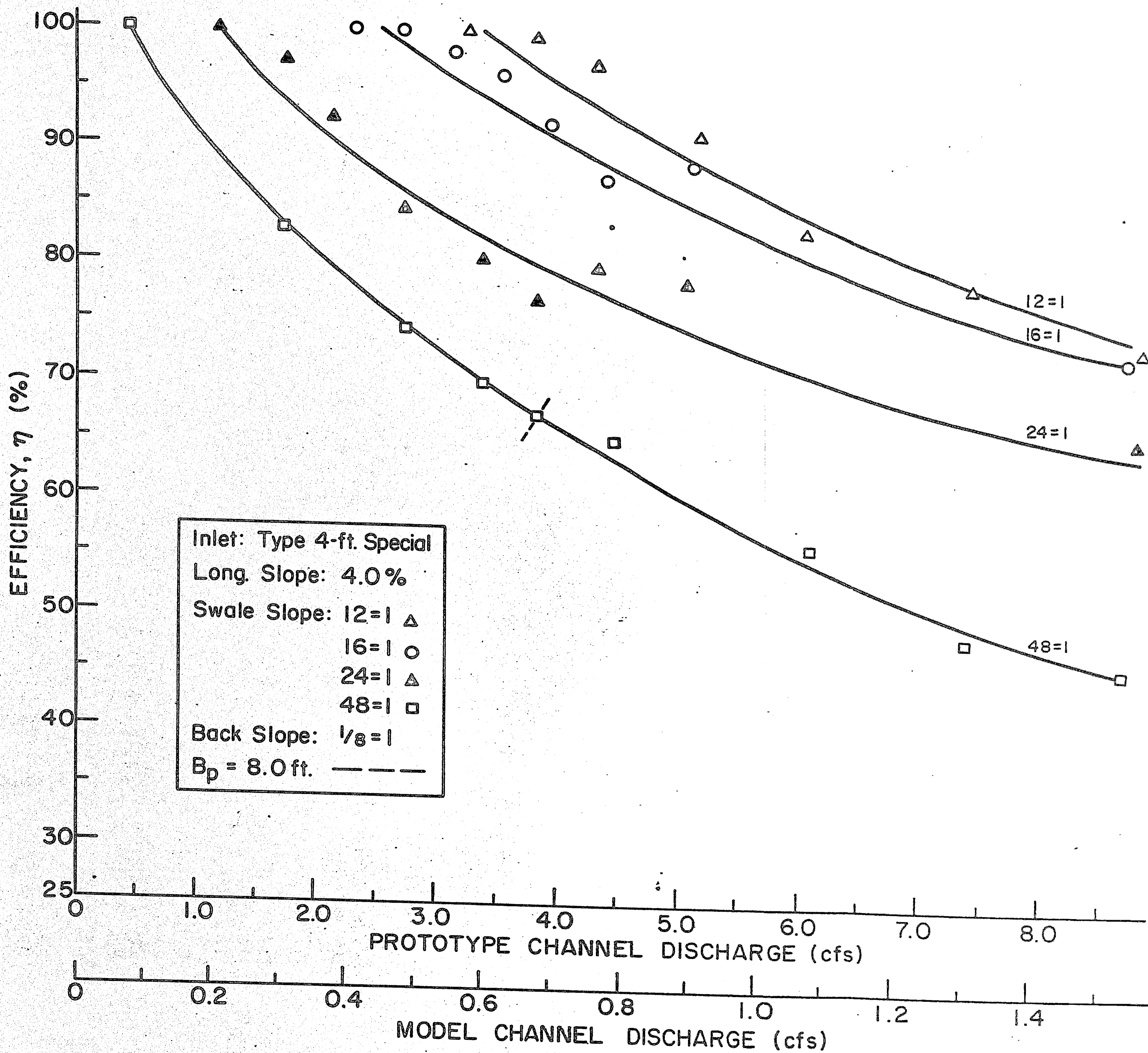

Fig. 4.7 Efficiency Curves; 4-Ft Special (Long. Slope = 4%)

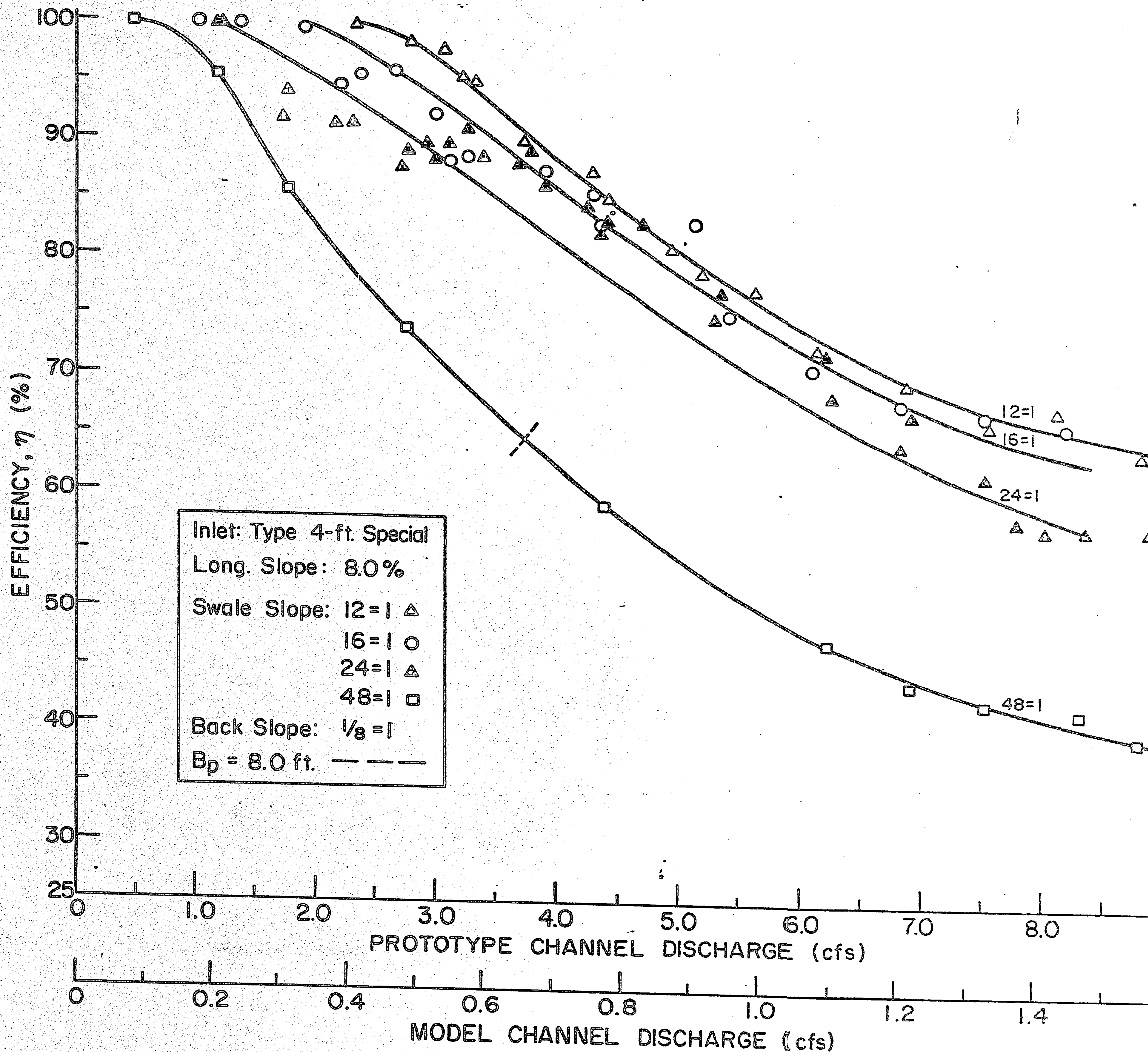

Fig. 4.8 Efficiency Curves; 4-Ft Special (Long. Slope = 8%)

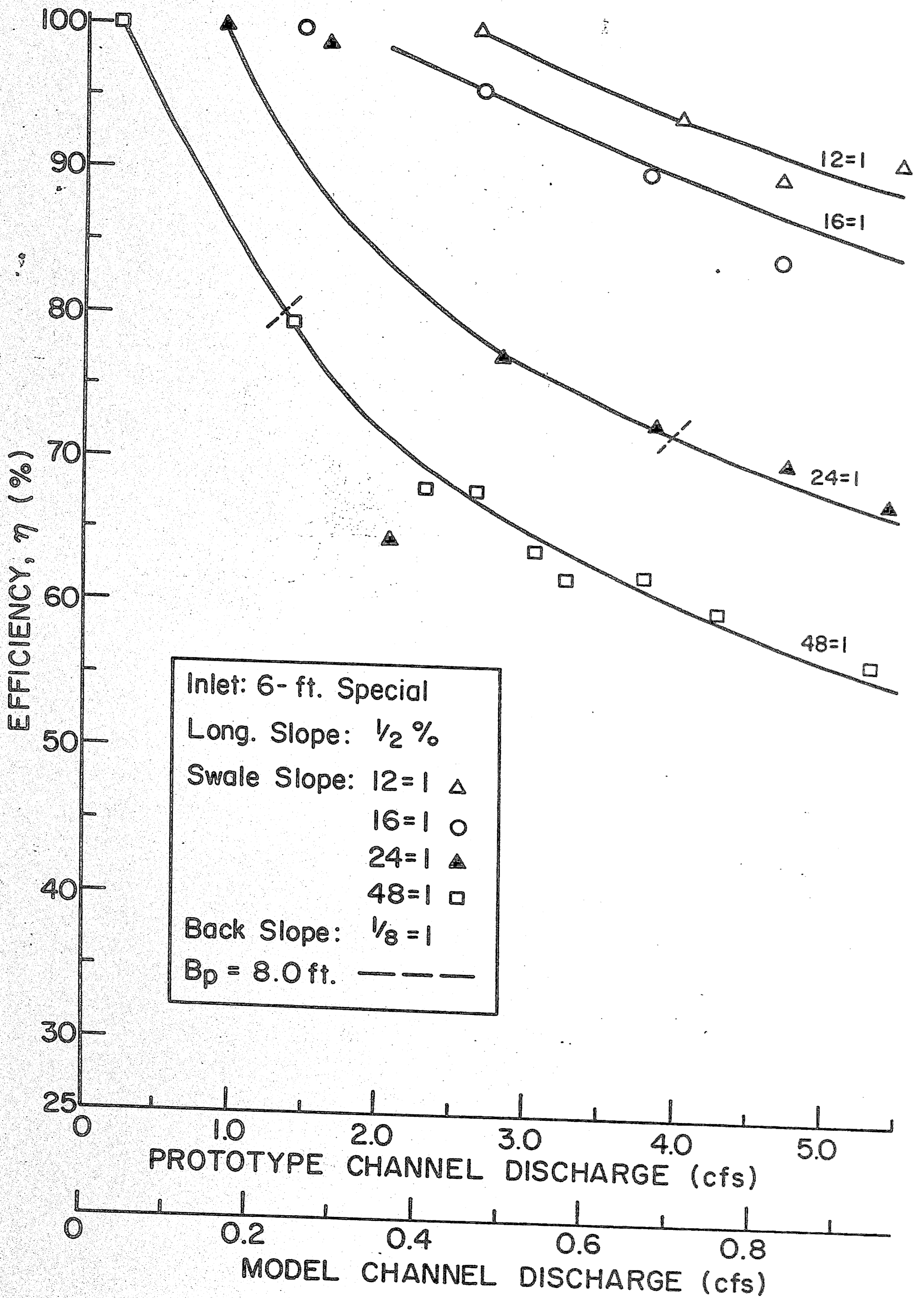

Fig. 4.9 Efficiency Curves; 6-Ft Special (Long. Slope = $\frac{1}{2}\%$)

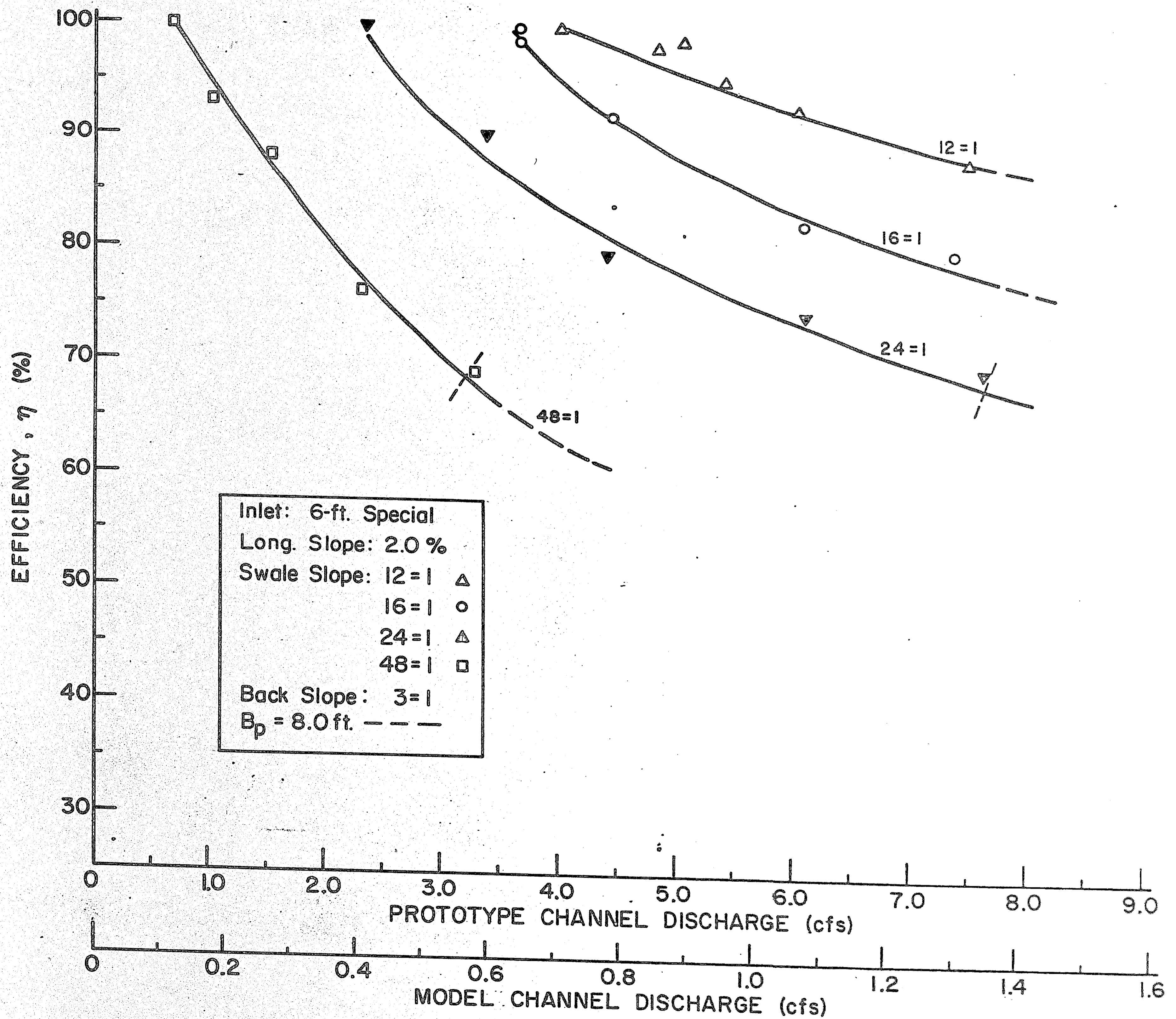

Fig. 4.10 Efficiency Curves; 6-Ft Special (Long. Slope = 2%)

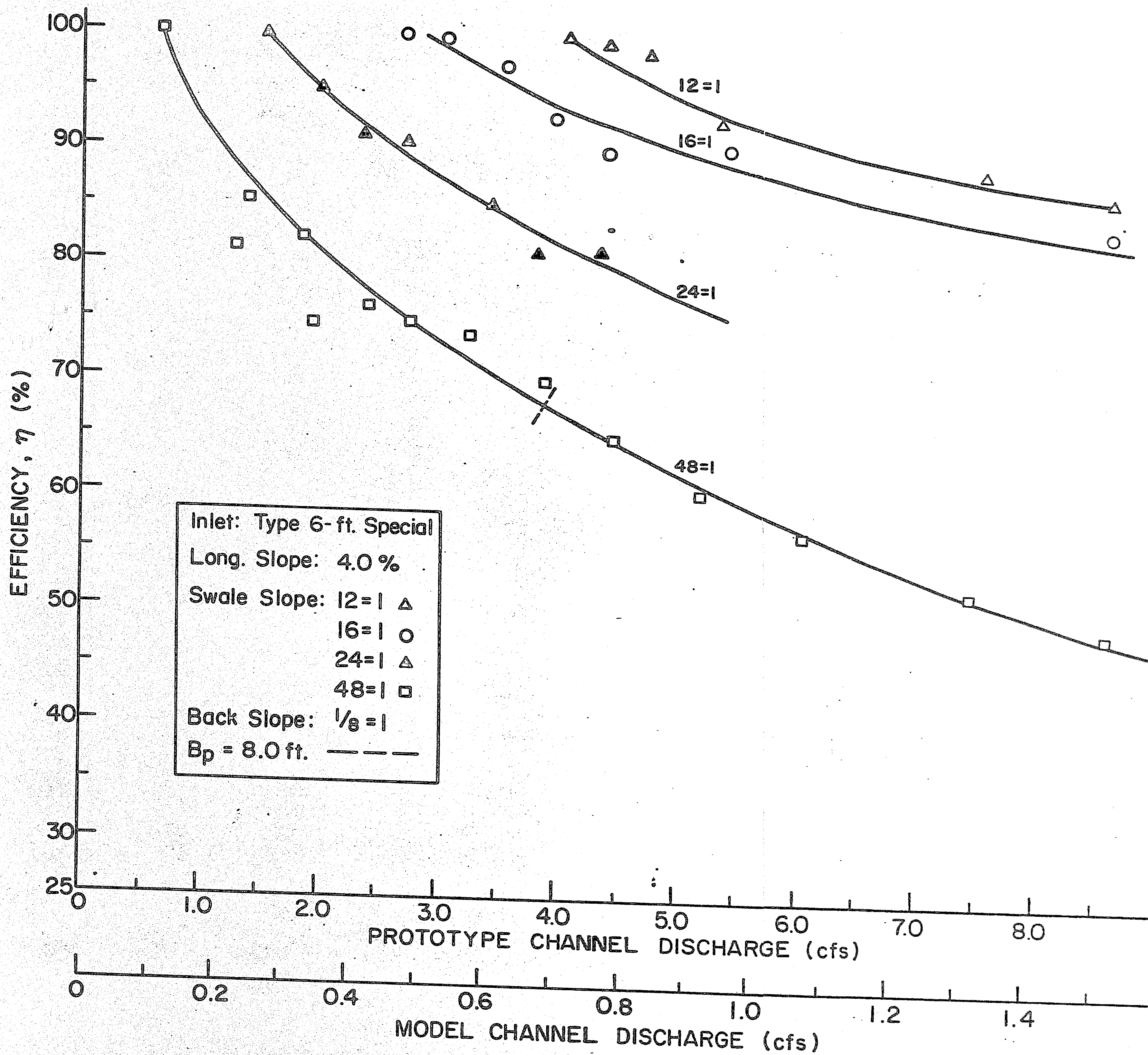

Fig. 4.11 Efficiency Curves; 6-Ft Special (Long. Slope = 4%)

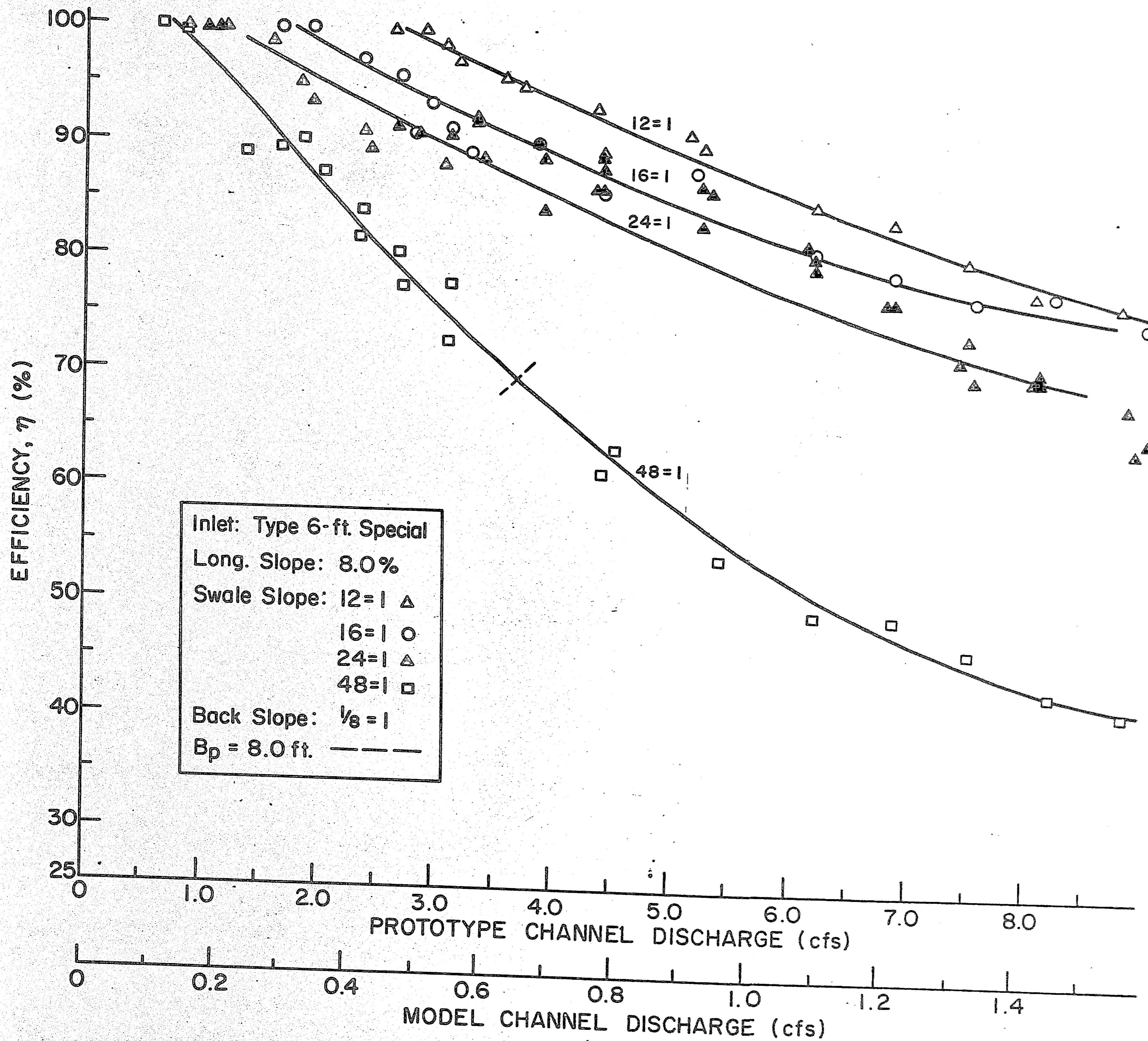

Fig. 4.12 Efficiency Curves; 6-Ft Special (Long. Slope = 8%)

5. LIST OF RECURRING SYMBOLS

- B - Width of water surface, ft.
D - Depth of channel, ft.
F - Force, lb.
Fr - Froude number.
g - Gravitational acceleration, ft/sec².
 ΔH - Pressure-head drop across orifice, ft.
L - Length, ft.
 l - Characteristic length, ft.
M - Mass, lb-sec²/ft.
n - Manning's roughness coefficient, ft^{1/6}.
Q - Flow rate (discharge), ft³/sec.
Q₁ - Channel flow rate, ft³/sec.
Q₂ - Intercepted flow rate, ft³/sec.
Q₃ - Carryover flow rate, ft³/sec.
Re - Reynolds number.
R_h - Hydraulic radius, ft.
T - Time, sec.
V - Volume, ft³.
v - Velocity, ft/sec.
 η - Efficiency, percent.
 ρ - Density, slug/ft³.
 ν - Kinematic viscosity, ft²/sec.

Subscripts

- m - Model
p - Prototype
R - Ratio

6. BIBLIOGRAPHY

1. Chow, V. T.
OPEN-CHANNEL HYDRAULICS, McGraw-Hill Book Company, New York, New York (1959).
2. Graf, W. H.
HYDRAULICS OF SEDIMENT TRANSPORT, McGraw-Hill Book Company, New York, New York (1971).
3. Guillou, J. C.
THE USE AND EFFICIENCY OF SOME GUTTER INLET GRATES, University of Illinois, Engineering Exp. Sta., Bull. 450 (July 1959).
4. Henderson, F. M.
OPEN CHANNEL FLOW, The Macmillan Company, New York, New York (1966).
5. Johns Hopkins University
THE DESIGN OF STORM-WATER INLETS, Dept. of San. Engineering and Water Resources, Report of the Storm Drainage Research Committee, Baltimore, Maryland (June 1956).
6. Larson, C. L. and L. G. Straub
GRATE INLETS FOR SURFACE DRAINAGE OF STREETS AND HIGHWAYS, University of Minnesota, St. Anthony Falls Hydraulic Laboratory, Bull. 2 (June 1949).
7. Morris, H. M.
APPLIED HYDRAULICS IN ENGINEERING, The Ronald Press Company, New York, New York (1963).
8. Stevens, J. C., et al.
HYDRAULIC MODELS, The Committee of the Hydraulics Division on Hydraulic Research, ASCE, Manual of Engineering Practice 25 (1942).
9. U. S. Army Corps of Engineers
SURFACE DRAINAGE FACILITIES FOR AIRFIELDS, EM 1110-345-281, (1964).
10. Vennard, J. K.
FLUID MECHANICS, 4th Edition, John Wiley and Sons, Incorporated, New York, New York (1966).
11. Yucel, O., et al.
DEVELOPMENT OF IMPROVED DRAINAGE INLETS, PHASE 1: LITERATURE SURVEY, Lehigh University, Fritz Engineering Laboratory Report No. 364.2, (1969).

7. APPENDIX - EXPERIMENTAL DATA

Test No.	Inlet	Long. Slope	Swale Slope	Back Slope	Page
4	Type J	1/2%	12:1	3:1	59
5	"	"	16:1	"	60
6	"	"	24:1	"	61
7	"	"	48:1	"	62
9	"	2%	12:1	"	63
10	"	"	16:1	"	64
11	"	"	24:1	"	65
12	"	"	48:1	"	66
14	"	4%	12:1	"	67
15	"	"	16:1	"	69
16	"	"	24:1	"	70
17	"	"	48:1	"	71
19	"	8%	12:1	"	72
20	"	"	16:1	"	74
21	"	"	24:1	"	76
22	"	"	48:1	"	78
26	4-Ft Special	"	48:1	1/8:1	80
27	6-Ft "	"	48:1	"	82
28	4-Ft "	"	24:1	"	85
29	6-Ft "	"	24:1	"	90
30	4-Ft "	"	16:1	"	96
31	6-Ft "	"	16:1	"	98
32	4-Ft "	"	12:1	"	101
33	6-Ft "	"	12:1	"	103
36	4-Ft "	4%	48:1	"	105
37	6-Ft "	"	48:1	"	106
38	4-Ft "	"	24:1	"	109
39	6-Ft "	"	24:1	"	110
40	4-Ft "	"	16:1	"	111
41	6-Ft "	"	16:1	"	112
42	4-Ft "	"	12:1	"	113
43	6-Ft "	"	12:1	"	114
46	4-Ft "	2%	48:1	"	115
47	6-Ft "	"	48:1	"	116
48	4-Ft "	"	24:1	"	117
49	6-Ft "	"	24:1	"	118
50	4-Ft "	"	16:1	"	119
51	6-Ft "	"	16:1	"	120
52	4-Ft "	"	12:1	"	121
53	6-Ft "	"	12:1	"	122
56	4-Ft "	1/2%	48:1	"	123
57	6-Ft "	"	48:1	"	124
58	4-Ft "	"	24:1	"	125
59	6-Ft "	"	24:1	"	126
60	4-Ft "	"	16:1	"	127
61	6-Ft "	"	16:1	"	128
62	4-Ft "	"	12:1	"	129
63	6-Ft "	"	12:1	"	130

Test No.: 4 Inlet: Type J Date: January 12, 72.

Long. Slope: 1/2% Swale Slope: 12:1 Back Slope: 3:1

Remarks: Depth taken at toe of divisor.

SYMBOLS

ΔH : Pressure-head drop across the orifice (ft. of water)

Q_1 : Channel discharge (cfs)

Q_2 : Discharge intercepted (cfs)

$Q_3 = Q_1 - Q_2$: Carryover (cfs)

\forall : Volume of water intercepted (ft.³)

T: Time (sec.)

η : Efficiency ($Q_2/Q_1 \times 100\%$)

B: Top width of channel (ft.)*

D: Depth of channel (ft.)*

* Measurements taken at stations 1 ft., 2 ft. and 3 ft. upstream from the start of the inlet grating.

ΔH	Q_1	\forall	T	Q_2	Q_3	η	B (Swale)	B (Back)	D
5.83	1.00	34.8	60.7	0.57	0.43	57.3	2.75	0.66	0.221
							2.75		0.230
3.36	0.76	27.8	60.8	0.46	0.30	60.1	2.75		0.227
							2.54	0.60	0.201
							2.58		0.208
2.06	0.59	23.5	60.7	0.39	0.20	65.5	2.58		0.209
							2.29	0.56	0.188
							2.33		0.186
1.04	0.42	17.8	60.5	0.29	0.13	69.8	2.42		0.196
							1.92	0.48	0.159
							2.00		0.165
0.38	0.25	12.2	60.5	0.20	0.05	80.7	2.04		0.173
							1.58	0.36	0.129
							1.71		0.138
0.10	0.12			0.12	0.00	100.0	1.83		0.144
							1.17	0.32	0.106
							1.29		0.109
							1.37		0.117

Test No.: 5 Inlet: Type J Date: January 11, 1972.

Long. Slope: 1/2% Swale Slope: 16:1 Back Slope: 3:1

Remarks: Depth taken at toe of divisor.

SYMBOLS

ΔH : Pressure-head drop across the orifice (ft. of water)

Q_1 : Channel discharge (cfs)

Q_2 : Discharge intercepted (cfs)

$Q_3 = Q_1 - Q_2$: Carryover (cfs)

\forall : Volume of water intercepted (ft.³)

T: Time (sec.)

η : Efficiency ($Q_2/Q_1 \times 100\%$)

B: Top width of channel (ft.)*

D: Depth of channel (ft.)*

* Measurements taken at stations 1 ft., 2 ft. and 3 ft. upstream from the start of the inlet grating.

ΔH	Q_1	\forall	T	Q_2	Q_3	η	B (Swale)	B (Back)	D
5.59	0.98	28.7	60.6	0.47	0.51	48.3	3.25	0.62	0.207
							3.25		0.204
3.40	0.77	23.5	60.5	0.39	0.38	50.5	3.25		0.211
							3.00	0.54	0.182
							3.00		0.197
2.03	0.59	20.2	60.5	0.33	0.26	56.5	3.00		0.190
							2.71	0.51	0.170
							2.75		0.172
1.14	0.44	16.8	60.7	0.28	0.16	62.9	2.75		0.173
							2.42	0.44	0.146
							2.46		0.158
0.39	0.26	11.3	60.5	0.19	0.07	71.7	2.46		0.164
							1.88	0.36	0.121
							1.96		0.131
0.058	0.10			0.10	0.00	100.0	2.04		0.134
							1.25	0.24	0.079
							1.38		0.082
							1.50		0.093

Test No.: 6 Inlet: Type J Date: January 6, 1972.
 Long. Slope: 1/2% Swale Slope: 24:1 Back Slope: 3:1
 Remarks: Depth taken at toe of divisor.

SYMBOLS

ΔH : Pressure-head drop across the orifice (ft. of water)
 Q_1 : Channel discharge (cfs)
 Q_2 : Discharge intercepted (cfs)
 $Q_3 = Q_1 - Q_2$: Carryover (cfs)
 Ψ : Volume of water intercepted (ft.³)
 T: Time (sec.)
 η : Efficiency ($Q_2/Q_1 \times 100\%$)
 B: Top width of channel (ft.)*
 D: Depth of channel (ft.)*

* Measurements taken at stations 1 ft., 2 ft. and 3 ft. upstream from the start of the inlet grating.

ΔH	Q_1	Ψ	T	Q_2	Q_3	η	B (Swale)	B (Back)	D
5.55	0.98	21.1	60.8	0.35	0.63	35.4	4.08	0.53	0.175
							4.08		0.182
3.58	0.79	17.9	59.6	0.30	0.49	38.0	4.08		0.187
							3.88	0.48	0.161
							3.88		0.167
2.06	0.59	15.0	60.9	0.25	0.34	41.8	3.88		0.170
							3.54	0.43	0.142
							3.54		0.157
0.99	0.41	12.1	59.9	0.20	0.21	49.4	3.54		0.148
							3.17	0.36	0.121
							3.21		0.128
0.42	0.27	9.1	60.6	0.15	0.12	55.5	3.21		0.133
							2.66	0.30	0.101
							2.71		0.118
0.12	0.13	6.6	60.4	0.11	0.02	84.2	2.75		0.122
							2.21	0.22	0.076
							2.25		0.090
0.042	0.084			0.08	0.00	100.0	2.33		0.100
							1.63	0.19	0.063
							1.79		0.073
							1.92		0.081

Test No.: 7 Inlet: Type J Date: Jan 5, 1972.

Long. Slope: 1/2% Swale Slope: 48:1 Back Slope: 3:1

Remarks: Depth taken at toe of divisor.

SYMBOLS

ΔH : Pressure-head drop across the orifice (ft. of water)

Q_1 : Channel discharge (cfs)

Q_2 : Discharge intercepted (cfs)

$Q_3 = Q_1 - Q_2$: Carryover (cfs)

Ψ : Volume of water intercepted (ft.³)

T: Time (sec.)

η : Efficiency ($Q_2/Q_1 \times 100\%$)

B: Top width of channel (ft.)*

D: Depth of channel (ft.)*

* Measurements taken at stations 1 ft., 2 ft. and 3 ft. upstream from the start of the inlet grating.

ΔH	Q_1	Ψ	T	Q_2	Q_3	η	B (Swale)	B (Back)	D
5.40	0.97	16.0	60.4	0.27	0.70	27.3	5.83	0.41	0.136
							5.95		0.142
2.80	0.70	11.7	60.3	0.19	0.51	27.8	6.00		0.135
							4.91	0.36	0.120
							5.08		0.130
2.22	0.62	10.7	60.4	0.18	0.44	28.6	5.25		0.133
							4.84	0.34	0.113
							4.84		0.122
1.31	0.48	9.1	60.5	0.15	0.33	31.3	5.00		0.126
							4.58	0.30	0.099
							4.54		0.109
0.93	0.40	7.8	60.7	0.13	0.27	32.1	4.66		0.118
							4.41	0.28	0.092
							4.41		0.103
0.47	0.28	6.2	60.5	0.10	0.18	36.6	4.33		0.110
							4.04	0.22	0.077
							4.00		0.088
0.13	0.14	5.3	60.6	0.09	0.05	62.4	4.00		0.095
							3.38	0.18	0.059
							3.38		0.068
0.008	0.04			0.04	0.00	100.0	3.46		0.082
							2.16	0.11	0.037
							2.29		0.041
							2.33		0.051

Test No.: 9 Inlet: Type J Date: Dec 9, 1971.

Long. Slope: 2.0 % Swale Slope: 12:1 Back Slope: 3:1

Remarks: Depth taken at toe of divisor.

SYMBOLS

ΔH : Pressure-head drop across the orifice (ft. of water)

Q_1 : Channel discharge (cfs)

Q_2 : Discharge intercepted (cfs)

$Q_3 = Q_1 - Q_2$: Carryover (cfs)

\forall : Volume of water intercepted (ft.³)

T: Time (sec.)

η : Efficiency ($Q_2/Q_1 \times 100\%$)

B: Top width of channel (ft.)*

D: Depth of channel (ft.)*

* Measurements taken at stations 1 ft., 2 ft. and 3 ft. upstream from the start of the inlet grating.

ΔH	Q_1	\forall	T	Q_2	Q_3	η	B (Swale)	B (Back)	D
5.55	0.98	32.0	60.5	0.53	0.45	53.9	2.33	0.58	0.193
							2.46	0.52	0.173
3.51	0.78	28.1	60.2	0.47	0.31	59.9	2.54	0.54	0.179
							2.00	0.55	0.183
							2.16	0.52	0.172
1.81	0.56	20.1	60.3	0.33	0.23	59.5	2.33	0.50	0.166
							1.67	0.49	0.163
							1.71	0.47	0.157
0.93	0.40	14.9	60.0	0.25	0.15	63.0	1.92	0.47	0.157
							1.50	0.40	0.132
							1.50	0.41	0.138
0.44	0.27	12.0	60.4	0.20	0.07	73.6	1.50	0.42	0.140
							1.37	0.34	0.112
							1.42	0.35	0.115
0.18	0.17	8.0	60.5	0.13	0.04	77.9	1.42	0.32	0.108
							1.08	0.30	0.099
							1.08	0.31	0.103
0.06	0.10			0.10	0.00	100.0	1.21	0.30	0.099
							0.88	0.24	0.079
							0.96	0.22	0.074
							1.00	0.21	0.071

Test No.: 10 Inlet: Type J Date: December 9, 71.

Long. Slope: 2.0 % Swale Slope: 16:1 Back Slope: 3:1

Remarks: Depth taken at toe of divisor.

SYMBOLS

ΔH : Pressure-head drop across the orifice (ft. of water)

Q_1 : Channel discharge (cfs)

Q_2 : Discharge intercepted (cfs)

$Q_3 = Q_1 - Q_2$: Carryover (cfs)

\forall : Volume of water intercepted (ft.³)

T: Time (sec.)

η : Efficiency ($Q_2/Q_1 \times 100\%$)

B: Top width of channel (ft.)*

D: Depth of channel (ft.)*

* Measurements taken at stations 1 ft., 2 ft. and 3 ft. upstream from the start of the inlet grating.

ΔH	Q_1	\forall	T	Q_2	Q_3	η	B (Swale)	B (Back)	D
5.14	0.94	25.5	60.6	0.42	0.52	44.7	2.66	0.50	0.166
							2.75	0.47	0.158
3.34	0.76	22.1	60.5	0.36	0.40	48.0	2.75	0.49	0.162
							2.50	0.46	0.154
1.91	0.57	19.4	62.9	0.31	0.26	54.0	2.62	0.45	0.151
							2.66	0.45	0.149
1.33	0.48	16.4	61.3	0.27	0.21	55.7	2.00	0.44	0.145
							2.16	0.41	0.138
0.59	0.32	11.3	60.1	0.19	0.13	59.6	2.34	0.41	0.137
							1.83	0.41	0.138
0.09	0.13	5.6	60.4	0.09	0.04	74.2	1.88	0.39	0.130
							2.00	0.39	0.131
0.03°	0.08			0.08	0.00	100.0	1.67	0.33	0.111
							1.67	0.33	0.110
							1.71	0.33	0.111
							1.17	0.22	0.073
							1.25	0.25	0.083
							1.29	0.23	0.078
							0.92	0.19	0.062
							0.96	0.20	0.067
							1.00	0.19	0.063

Test No.: 11 Inlet: Type J Date: Dec 6, 1971.

Long. Slope: 2.0 % Swale Slope: 24:1 Back Slope: 3:1

Remarks: Depth taken at toe of divisor.

SYMBOLS

ΔH : Pressure-head drop across the orifice (ft. of water)

Q_1 : Channel discharge (cfs)

Q_2 : Discharge intercepted (cfs)

$Q_3 = Q_1 - Q_2$: Carryover (cfs)

\forall : Volume of water intercepted (ft.³)

T: Time (sec.)

η : Efficiency ($Q_2/Q_1 \times 100\%$)

B: Top width of channel (ft.)*

D: Depth of channel (ft.)*

* Measurements taken at stations 1 ft., 2 ft. and 3 ft. upstream from the start of the inlet grating.

ΔH	Q_1	\forall	T	Q_2	Q_3	η	B (Swale)	B (Back)	D
5.05	0.94	17.7	60.6	0.29	0.65	31.0	3.37	0.44	0.148
							3.33	0.44	0.145
							3.33	0.42	0.139
3.48	0.78	15.0	60.5	0.25	0.53	31.8	3.25	0.39	0.131
							3.25	0.40	0.133
							3.25	0.39	0.130
1.73	0.55	12.2	60.7	0.20	0.35	36.5	3.00	0.34	0.113
							3.00	0.33	0.110
							2.96	0.32	0.107
0.88	0.39	10.4	60.6	0.17	0.22	44.5	2.46	0.30	0.101
							2.54	0.30	0.101
							2.62	0.29	0.098
0.29	0.22	7.0	60.6	0.12	0.10	52.5	1.83	0.26	0.085
							1.83	0.26	0.085
							1.96	0.26	0.085
0.09	0.13	4.8	60.6	0.08	0.05	63.5	1.54	0.20	0.067
							1.54	0.21	0.071
							1.54	0.20	0.065
0.02	0.05			0.05	0.00	100.0	0.92	0.13	0.044
							0.96	0.14	0.046
							1.00	0.12	0.041

Test No.: 12 Inlet: Type J Date: Dec 6, 1971.

Long. Slope: 2.0 % Swale Slope: 48:1 Back Slope: 3:1

Remarks: Depth taken at toe of divisor.

SYMBOLS

ΔH : Pressure-head drop across the orifice (ft. of water)

Q_1 : Channel discharge (cfs)

Q_2 : Discharge intercepted (cfs)

$Q_3 = Q_1 - Q_2$: Carryover (cfs)

Ψ : Volume of water intercepted (ft.³)

T: Time (sec.)

η : Efficiency ($Q_2/Q_1 \times 100\%$)

B: Top width of channel (ft.)*

D: Depth of channel (ft.)*

* Measurements taken at stations 1 ft., 2 ft. and 3 ft. upstream from the start of the inlet grating.

ΔH	Q_1	Ψ	T	Q_2	Q_3	η	B (Swale)	B (Back)	D
4.75	0.90	11.3	60.5	0.19	0.71	20.8	4.50	0.31	0.103
							4.58	0.31	0.104
3.38	0.76	11.0	60.6	0.18	0.58	23.8	4.75	0.31	0.102
							4.25	0.30	0.099
							4.33	0.29	0.098
1.73	0.55	9.6	60.5	0.16	0.39	28.9	4.45	0.28	0.094
							3.71	0.28	0.092
							3.71	0.27	0.089
1.02	0.42	7.6	60.5	0.13	0.29	30.3	3.92	0.26	0.085
							3.50	0.26	0.088
							3.50	0.26	0.086
0.58	0.32	5.9	60.5	0.10	0.22	30.9	3.54	0.24	0.080
							3.25	0.21	0.069
							3.25	0.24	0.079
0.26	0.21	4.9	60.6	0.08	0.13	38.5	3.21	0.21	0.071
							2.88	0.17	0.057
							2.92	0.20	0.065
0.10	0.12	3.9	60.6	0.06	0.06	53.5	2.92	0.18	0.059
							2.21	0.15	0.051
							2.29	0.16	0.053
0.02	0.05			0.05	0.00	100.0	2.38	0.16	0.052
							1.37	0.11	0.035
							1.37	0.11	0.038
							1.42	0.11	0.037

Test No.: 14 Inlet: Type J Date: Nov 15, 1971

Long. Slope: 4.0 % Swale Slope: 12:1 Back Slope: 3:1

Remarks: Depth taken at toe of divisor.

SYMBOLS

ΔH : Pressure-head drop across the orifice (ft. of water)

Q_1 : Channel discharge (cfs)

Q_2 : Discharge intercepted (cfs)

$Q_3 = Q_1 - Q_2$: Carryover (cfs)

Ψ : Volume of water intercepted (ft.³)

T: Time (sec.)

η : Efficiency ($Q_2/Q_1 \times 100\%$)

B: Top width of channel (ft.)*

D: Depth of channel (ft.)*

* Measurements taken at stations 1 ft., 2 ft. and 3 ft. upstream from the start of the inlet grating.

ΔH	Q_1	Ψ	T	Q_2	Q_3	η	B (Swale)	B (Back)	D
5.35	0.96	28.8	60.3	0.48	0.48	49.7	1.83	0.48	0.160
							1.83	0.49	0.164
							1.88	0.49	0.164
3.43	0.77	23.7	60.5	0.39	0.38	51.0	1.79	0.45	0.150
							1.79	0.45	0.151
							1.79	0.45	0.149
2.16	0.61	19.3	60.4	0.32	0.29	52.3	1.62	0.40	0.134
							1.71	0.41	0.135
							1.71	0.41	0.138
1.74	0.55	18.2	60.4	0.30	0.25	54.8	1.58	0.39	0.129
							1.67	0.38	0.127
							1.67	0.39	0.131
1.41	0.49	17.4	60.5	0.29	0.20	58.7	1.46	0.37	0.123
							1.58	0.38	0.127
							1.58	0.37	0.123
1.08	0.43	15.9	60.5	0.26	0.17	61.1	1.37	0.35	0.117
							1.50	0.36	0.121
							1.58	0.35	0.118
0.82	0.37	13.9	60.5	0.23	0.14	62.1	1.25	0.34	0.112
							1.37	0.34	0.114
							1.42	0.35	0.115
0.49	0.29	10.9	60.5	0.18	0.11	62.1	1.17	0.31	0.102
							1.17	0.31	0.103
							1.33	0.31	0.104
0.29	0.22	9.3	60.4	0.15	0.07	70.0	1.08	0.28	0.093
							1.04	0.28	0.093
							1.08	0.27	0.089

Test No.: 14 Cont'd Inlet: Type J Date: Nov 15, 1971

Long. Slope: 4.0 % Swale Slope: 12:1 Back Slope: 3:1

Remarks: Depth taken at toe of divisor.

SYMBOLS

ΔH : Pressure-head drop across the orifice (ft. of water)

Q_1 : Channel discharge (cfs)

Q_2 : Discharge intercepted (cfs)

$Q_3 = Q_1 - Q_2$: Carryover (cfs)

\forall : Volume of water intercepted (ft.³)

T: Time (sec.)

η : Efficiency ($Q_2/Q_1 \times 100\%$)

B: Top width of channel (ft.)*

D: Depth of channel (ft.)*

* Measurements taken at stations 1 ft., 2 ft. and 3 ft. upstream from the start of the inlet grating.

ΔH	Q_1	\forall	T	Q_2	Q_3	η	B (Swale)	B (Back)	D
0.16	0.16	7.2	60.5	0.12	0.04	76.0	0.96	0.24	0.079
							0.96	0.25	0.084
0.04	0.08			0.08	0.00	100.0	1.00	0.25	0.082
							0.71	0.18	0.059
							0.75	0.20	0.065
							0.75	0.19	0.064

Test No.: 15 Inlet: Type J Date: Nov 18, 71.

Long. Slope: 4.0 % Swale Slope: 16:1 Back Slope: 3:1

Remarks: Depth taken at toe of divisor.

SYMBOLS

- ΔH : Pressure-head drop across the orifice (ft. of water)
 Q_1 : Channel discharge (cfs)
 Q_2 : Discharge intercepted (cfs)
 $Q_3 = Q_1 - Q_2$: Carryover (cfs)
 \forall : Volume of water intercepted (ft.³)
T: Time (sec.)
 η : Efficiency ($Q_2/Q_1 \times 100\%$)
B: Top width of channel (ft.)*
D: Depth of channel (ft.)*

* Measurements taken at stations 1 ft., 2 ft. and 3 ft. upstream from the start of the inlet grating.

ΔH	Q_1	\forall	T	Q_2	Q_3	η	B (Swale)	B (Back)	D
4.99	0.93	31.2	90.8	0.34	0.59	36.9	2.25	0.42	0.141
							2.25	0.42	0.141
3.30	0.76	28.2	92.1	0.31	0.45	40.3	2.25	0.44	0.145
							2.21	0.38	0.126
							2.21	0.38	0.125
2.18	0.61	24.9	91.1	0.27	0.34	44.3	2.21	0.38	0.126
							2.12	0.36	0.120
							2.12	0.34	0.113
1.33	0.48	22.2	90.7	0.24	0.24	51.0	2.12	0.34	0.112
							1.87	0.34	0.114
							1.96	0.32	0.105
0.80	0.37	18.1	91.3	0.20	0.17	53.6	2.00	0.31	0.104
							1.42	0.28	0.093
							1.62	0.31	0.102
0.47	0.28	14.3	90.7	0.16	0.12	56.4	1.75	0.30	0.099
							1.21	0.29	0.097
							1.33	0.29	0.097
0.20	0.18	10.4	90.6	0.11	0.07	63.8	1.50	0.28	0.095
							1.17	0.25	0.082
							1.12	0.25	0.084
0.08	0.11	8.1	90.6	0.09	0.02	79.1	1.17	0.26	0.088
							1.08	0.20	0.066
							1.08	0.22	0.072
0.02	0.05			0.05	0.00	100.0	1.08	0.21	0.070
							0.75	0.14	0.045
							0.79	0.14	0.048
							0.79	0.15	0.049

Test No.: 16 Inlet: Type J Date: Nov 17, 1971

Long. Slope: 4.0 % Swale Slope: 24:1 Back Slope: 3:1

Remarks: Depth taken at toe of divisor.

SYMBOLS

ΔH : Pressure-head drop across the orifice (ft. of water)

Q_1 : Channel discharge (cfs)

Q_2 : Discharge intercepted (cfs)

$Q_3 = Q_1 - Q_2$: Carryover (cfs)

Ψ : Volume of water intercepted (ft.³)

T: Time (sec.)

η : Efficiency ($Q_2/Q_1 \times 100\%$)

B: Top width of channel (ft.)*

D: Depth of channel (ft.)*

* Measurements taken at stations 1 ft., 2 ft. and 3 ft. upstream from the start of the inlet grating.

ΔH	Q_1	Ψ	T	Q_2	Q_3	η	B (Swale)	B (Back)	D
3.01	0.72	23.9	90.6	0.26	0.46	35.6	2.42	0.37	0.122
							2.42	0.37	0.123
2.11	0.60	19.0	91.0	0.21	0.39	34.8	2.42	0.36	0.120
							2.37	0.33	0.110
0.73	0.35	14.6	90.5	0.16	0.19	46.1	2.37	0.33	0.110
							2.37	0.35	0.116
0.43	0.27	13.5	92.2	0.15	0.12	54.1	2.17	0.25	0.083
							2.17	0.24	0.081
0.03	0.07			0.07	0.00	100.0	2.17	0.24	0.084
							2.12	0.24	0.079
							2.12	0.24	0.080
							2.12	0.23	0.076
							1.50	0.22	0.072
							1.71	0.22	0.073
							1.75	0.20	0.066

Test No.: 17 Inlet: Type J Date: Nov 16, 1971
 Long. Slope: 4.0 % Swale Slope: 48:1 Back Slope: 3:1
 Remarks: Depth taken at toe of divisor.

SYMBOLS

- ΔH : Pressure-head drop across the orifice (ft. of water)
 Q_1 : Channel discharge (cfs)
 Q_2 : Discharge intercepted (cfs)
 $Q_3 = Q_1 - Q_2$: Carryover (cfs)
 Ψ : Volume of water intercepted (ft.³)
 T: Time (sec.)
 η : Efficiency ($Q_2/Q_1 \times 100\%$)
 B: Top width of channel (ft.)*
 D: Depth of channel (ft.)*

* Measurements taken at stations 1 ft., 2 ft. and 3 ft. upstream from the start of the inlet grating.

ΔH	Q_1	Ψ	T	Q_2	Q_3	η	B (Swale)	B (Back)	D
1.61	0.53	9.3	59.8	0.16	0.37	29.4	3.42	0.24	0.081
							3.63	0.23	0.076
1.61	0.53			0.15	0.38	28.7	3.75	0.21	0.071
1.27	0.47	17.3	119.6	0.14	0.33	30.8	3.16	0.24	0.080
							3.42	0.23	0.076
0.97	0.41	15.6	119.3	0.13	0.28	31.9	3.58	0.23	0.075
							3.00	0.23	0.077
							3:25	0.23	0.075
0.71	0.35	13.5	119.8	0.11	0.24	32.6	3.42	0.22	0.074
							2.75	0.22	0.072
							2.83	0.22	0.073
0.47	0.28	11.4	119.7	0.10	0.18	34.0	3.33	0.21	0.070
							2.54	0.19	0.062
							2.54	0.20	0.068
0.29	0.22	9.1	122.7	0.07	0.15	33.7	2.54	0.20	0.065
							2.38	0.17	0.056
							2.38	0.19	0.063
0.18	0.17	7.9	120.5	0.07	0.10	39.0	2.38	0.17	0.058
							2.29	0.14	0.048
							2.29	0.17	0.056
0.09	0.13	6.3	120.6	0.05	0.08	41.5	2.29	0.16	0.052
							2.08	0.13	0.043
							2.12	0.14	0.045
0.02	0.05			0.05	0.00	100.0	2.12	0.14	0.045
							1.04	0.08	0.026
							1.08	0.09	0.031
							1.17	0.08	0.026

Test No.: 19 Inlet: Type J Date: August 10, 1971

Long. Slope: 8.0 % Swale Slope: 12:1 Back Slope: 3:1

Remarks: Depth taken at toe of divisor.

SYMBOLS

- ΔH : Pressure-head drop across the orifice (ft. of water)
 Q_1 : Channel discharge (cfs)
 Q_2 : Discharge intercepted (cfs)
 $Q_3 = Q_1 - Q_2$: Carryover (cfs)
 Ψ : Volume of water intercepted (ft.³)
T: Time (sec.)
 η : Efficiency ($Q_2/Q_1 \times 100\%$)
B: Top width of channel (ft.)*
D: Depth of channel (ft.)*

* Measurements taken at stations 1 ft., 2 ft. and 3 ft. upstream from the start of the inlet grating.

ΔH	Q_1	Ψ	T	Q_2	Q_3	η	B (Swale)	B (Back)	D
14.33	1.59	21.0	40.4	0.52	1.07	32.7	1.88	0.48	0.159
							2.04	0.49	0.162
							2.16	0.49	0.163
12.73	1.49	19.7	40.3	0.49	1.00	32.8	1.84	0.48	0.160
							1.92	0.49	0.163
							2.12	0.48	0.160
9.98	1.32	18.9	40.5	0.47	0.85	35.4	1.83	0.47	0.155
							1.75	0.47	0.156
							1.91	0.44	0.147
6.68	1.08	16.7	40.2	0.41	0.67	38.3	1.67	0.43	0.143
							1.75	0.44	0.145
							1.62	0.44	0.145
3.33	0.76	13.2	40.5	0.33	0.43	43.0	1.54	0.40	0.132
							1.50	0.38	0.127
							1.46	0.38	0.127
2.55	0.66	11.9	40.5	0.29	0.37	44.6	1.50	0.36	0.121
							1.46	0.36	0.120
							1.42	0.37	0.123
1.92	0.57	10.3	40.4	0.26	0.31	44.5	1.46	0.33	0.110
							1.46	0.34	0.112
							1.42	0.34	0.113
1.18	0.45	12.9	60.3	0.21	0.24	47.5	1.33	0.28	0.094
							1.37	0.27	0.090
							1.33	0.28	0.094
0.60	0.32	10.0	60.6	0.17	0.15	51.5	0.88	0.26	0.086
							1.00	0.23	0.076
							1.12	0.23	0.077

Test No.: 19(Cont'd) Inlet: Type J Date: August 10, 1971.

Long. Slope: 8% Swale Slope: 12:1 Back Slope: 3:1

Remarks: Depth taken at toe of divisor.

SYMBOLS

ΔH : Pressure-head drop across the orifice (ft. of water)

Q_1 : Channel discharge (cfs)

Q_2 : Discharge intercepted (cfs)

$Q_3 = Q_1 - Q_2$: Carryover (cfs)

Ψ : Volume of water intercepted (ft.³)

T: Time (sec.)

η : Efficiency ($Q_2/Q_1 \times 100\%$)

B: Top width of channel (ft.)*

D: Depth of channel (ft.)*

* Measurements taken at stations 1 ft., 2 ft. and 3 ft. upstream from the start of the inlet grating.

ΔH	Q_1	Ψ	T	Q_2	Q_3	η	B (Swale)	B (Back)	D
0.33	0.24			0.24	0.00	100.0	0.54	0.12	0.040
							0.54	0.13	0.044
							0.50	0.14	0.047

Test No.: 20 Inlet: Type J Date: August 23, 1971.

Long. Slope: 8 % Swale Slope: 16:1 Back Slope: 3:1

Remarks: Depth taken at toe of divisor.

SYMBOLS

ΔH : Pressure-head drop across the orifice (ft. of water)

Q_1 : Channel discharge (cfs)

Q_2 : Discharge intercepted (cfs)

$Q_3 = Q_1 - Q_2$: Carryover (cfs)

Ψ : Volume of water intercepted (ft.³)

T: Time (sec.)

η : Efficiency ($Q_2/Q_1 \times 100\%$)

B: Top width of channel (ft.)*

D: Depth of channel (ft.)*

* Measurements taken at stations 1 ft., 2 ft. and 3 ft. upstream from the start of the inlet grating.

ΔH	Q_1	Ψ	T	Q_2	Q_3	η	B (Swale)	B (Back)	D
14.50	1.60	28.5	60.5	0.47	1.13	29.4	2.75	0.48	0.159
							2.87	0.48	0.160
12.70	1.50	28.8	60.6	0.48	1.02	31.6	2.96	0.46	0.152
							2.67	0.47	0.157
							2.75	0.48	0.159
10.20	1.33	26.8	60.5	0.44	0.89	33.3	2.88	0.45	0.148
							2.42	0.46	0.152
							2.54	0.47	0.156
6.88	1.10	22.9	60.6	0.38	0.72	34.3	2.63	0.44	0.148
							2.00	0.43	0.142
							2.12	0.43	0.144
3.40	0.77	19.4	60.6	0.32	0.45	41.5	2.29	0.43	0.144
							1.50	0.38	0.126
							1.58	0.38	0.125
1.59	0.52	13.9	60.4	0.23	0.29	44.3	1.71	0.38	0.125
							1.42	0.33	0.110
							1.42	0.33	0.109
1.09	0.44	11.1	60.4	0.18	0.26	42.5	1.33	0.32	0.108
							1.42	0.33	0.099
							1.42	0.33	0.099
0.53	0.30	8.9	60.6	0.15	0.15	49.0	1.38	0.33	0.099
							1.37	0.23	0.077
							1.37	0.23	0.076
0.38	0.26	14.3	100.3	0.14	0.12	56.0	1.37	0.23	0.075
0.26	0.21	8.7	60.3	0.14	0.07	69.4	1.17	0.21	0.070
							1.29	0.20	0.068
							1.33	0.19	0.062

Test No.: 20 (Cont'd) Inlet: Type J Date: August 23, 1971.

Long. Slope: 8.0 % Swale Slope: 16:1 Back Slope: 3:1

Remarks: Depth taken at toe of divisor.

SYMBOLS

ΔH : Pressure-head drop across the orifice (ft. of water)

Q_1 : Channel discharge (cfs)

Q_2 : Discharge intercepted (cfs)

$Q_3 = Q_1 - Q_2$: Carryover (cfs)

V : Volume of water intercepted (ft.³)

T: Time (sec.)

η : Efficiency ($Q_2/Q_1 \times 100\%$)

B: Top width of channel (ft.)*

D: Depth of channel (ft.)*

* Measurements taken at stations 1 ft., 2 ft. and 3 ft. upstream from the start of the inlet grating.

ΔH	Q_1	V	T	Q_2	Q_3	η	B (Swale)	B (Back)	D
0.24	0.20	14.1	100.3	0.14	0.06	70.0			
0.05	0.09	4.2	60.4	0.07	0.02	74.8	0.71	0.15	0.051
							0.71	0.17	0.058
0.02	0.06			0.06	0.00	100.0	0.75	0.17	0.058
							0.54	0.12	0.039
							0.54	0.13	0.044
							0.54	0.12	0.039

Test No.: 21 Inlet: Type J Date: August 12, 1971.

Long. Slope: 8% Swale Slope: 24:1 Back Slope: 3:1

Remarks: Depth taken at toe of divisor.

SYMBOLS

ΔH : Pressure-head drop across the orifice (ft. of water)

Q_1 : Channel discharge (cfs)

Q_2 : Discharge intercepted (cfs)

$Q_3 = Q_1 - Q_2$: Carryover (cfs)

\forall : Volume of water intercepted (ft.³)

T: Time (sec.)

η : Efficiency ($Q_2/Q_1 \times 100\%$)

B: Top width of channel (ft.)*

D: Depth of channel (ft.)*

* Measurements taken at stations 1 ft., 2 ft. and 3 ft. upstream from the start of the inlet grating.

ΔH	Q_1	\forall	T	Q_2	Q_3	η	B (Swale)	B (Back)	D
14.40	1.60	22.0	60.6	0.36	1.24	22.7	3.21	0.38	0.127
							3.42	0.38	0.126
13.40	1.53	21.6	60.3	0.36	1.17	23.4	3.50	0.39	0.131
							3.16	0.38	0.128
							3.42	0.38	0.125
6.85	1.10	20.3	60.6	0.34	0.76	30.5	3.50	0.38	0.128
							2.46	0.37	0.124
							2.50	0.37	0.122
3.40	0.77	16.4	60.4	0.27	0.50	35.4	2.54	0.36	0.120
							1.83	0.35	0.115
							1.92	0.36	0.121
1.77	0.55	11.6	60.5	0.19	0.36	34.8	2.00	0.35	0.117
							1.79	0.30	0.100
							1.67	0.32	0.107
0.26	0.21	5.7	60.6	0.09	0.12	45.2	1.58	0.32	0.107
							1.50	0.15	0.049
							1.50	0.16	0.053
0.23	0.20	9.1	100.4	0.09	0.11	45.3	1.54	0.14	0.048
							1.50	0.17	0.057
							1.50	0.20	0.064
0.08	0.11	7.9	101.4	0.08	0.03	69.1	1.46	0.18	0.060
							1.25	0.14	0.048
							1.33	0.15	0.050
0.13	0.15	8.5	100.3	0.08	0.07	56.5	1.33	0.13	0.042
							1.42	0.15	0.049
							1.46	0.16	0.054
							1.46	0.15	0.050

Test No.: 21 (Cont'd) Inlet: Type J Date: August 12, 1971.

Long. Slope: 8 % Swale Slope: 24:1 Back Slope: 3:1

Remarks: Depth taken at toe of divisor.

SYMBOLS

ΔH : Pressure-head drop across the orifice (ft. of water)

Q_1 : Channel discharge (cfs)

Q_2 : Discharge intercepted (cfs)

$Q_3 = Q_1 - Q_2$: Carryover (cfs)

\forall : Volume of water intercepted (ft.³)

T: Time (sec.)

η : Efficiency ($Q_2/Q_1 \times 100\%$)

B: Top width of channel (ft.)*

D: Depth of channel (ft.)*

* Measurements taken at stations 1 ft., 2 ft. and 3 ft. upstream from the start of the inlet grating.

ΔH	Q_1	\forall	T	Q_2	Q_3	η	B (Swale)	B (Back)	D
0.06	0.10			0.10	0.00	100.0	0.54 0.54 0.54		

Test No.: 22 Inlet: Type J Date: August 13, 1971.

Long. Slope: 8% Swale Slope: 48:1 Back Slope: 3:1

Remarks: Depth taken at toe of divisor.

SYMBOLS

- ΔH : Pressure-head drop across the orifice (ft. of water)
 Q_1 : Channel discharge (cfs)
 Q_2 : Discharge intercepted (cfs)
 $Q_3 = Q_1 - Q_2$: Carryover (cfs)
 Ψ : Volume of water intercepted (ft.³)
T: Time (sec.)
 η : Efficiency ($Q_2/Q_1 \times 100\%$)
B: Top width of channel (ft.)*
D: Depth of channel (ft.)*

* Measurements taken at stations 1 ft., 2 ft. and 3 ft. upstream from the start of the inlet grating.

ΔH	Q_1	Ψ	T	Q_2	Q_3	η	B (Swale)	B (Back)	D
14.00	1.58	12.4	60.4	0.21	1.37	13.0	4.95	0.29	0.096
							5.04	0.29	0.096
11.20	1.40	11.7	60.3	0.19	1.21	13.9	5.08	0.29	0.096
							4.66	0.28	0.094
							4.70	0.29	0.096
6.88	1.10	10.8	60.5	0.18	0.92	16.2	4.80	0.29	0.095
							4.20	0.27	0.090
							4.25	0.27	0.090
3.48	0.78	9.8	60.5	0.16	0.62	20.8	4.37	0.26	0.087
							3.75	0.26	0.085
							3.79	0.25	0.082
1.72	0.55	8.8	60.4	0.15	0.40	26.6	3.88	0.24	0.080
							3.04	0.22	0.074
							3.21	0.22	0.073
1.23	0.47	9.8	74.9	0.13	0.34	28.2	3.42	0.21	0.071
									0.073
									0.073
0.78	0.36	6.4	60.6	0.11	0.25	29.2	2.50	0.20	0.068
							2.58	0.21	0.070
0.43	0.27	5.6	60.5	0.09	0.18	34.3	2.58	0.20	0.065
							1.96	0.17	0.057
							2.00	0.19	0.062
0.09	0.13	4.1	90.4	0.05	0.08	36.3	2.21	0.17	0.058
							1.67	0.12	0.039
							1.63	0.13	0.043
							1.54	0.11	0.038

Test No.: 22 (Cont'd) Inlet: Type J Date: August 13, 1971.

Long. Slope: 8 % Swale Slope: 48:1 Back Slope: 3:1

Remarks: Depth taken at toe of divisor.

SYMBOLS

ΔH : Pressure-head drop across the orifice (ft. of water)

Q_1 : Channel discharge (cfs)

Q_2 : Discharge intercepted (cfs)

$Q_3 = Q_1 - Q_2$: Carryover (cfs)

\forall : Volume of water intercepted (ft.³)

T: Time (sec.)

η : Efficiency ($Q_2/Q_1 \times 100\%$)

B: Top width of channel (ft.)*

D: Depth of channel (ft.)*

* Measurements taken at stations 1 ft., 2 ft. and 3 ft. upstream from the start of the inlet grating.

ΔH	Q_1	\forall	T	Q_2	Q_3	η	B (Swale)	B (Back)	D
0.008	0.04			0.04	0.00	100.0	0.75	0.06	0.022
							0.79	0.07	0.024
							0.83	0.06	0.021

Test No.: 26 Inlet: 4-Ft Special Date: Sept 9, 1971.

Long. Slope: 8% Swale Slope: 48:1 Back Slope: 1/8:1

Remarks: Depth taken at toe of curb. Spread onto back slope less than 0.05 ft.

SYMBOLS

ΔH : Pressure-head drop across the orifice (ft. of water)

Q_1 : Channel discharge (cfs)

Q_2 : Discharge intercepted (cfs)

$Q_3 = Q_1 - Q_2$: Carryover (cfs)

Ψ : Volume of water intercepted (ft.³)

T: Time (sec.)

η : Efficiency ($Q_2/Q_1 \times 100\%$)

B: Top width of channel (ft.)*

D: Depth of channel (ft.)*

* Measurements taken at stations 1 ft., 2 ft. and 3 ft. upstream from the start of the inlet grating.

ΔH	Q_1	Ψ	T	Q_2	Q_3	η	B (Swale)	B (Back)	D
13.64	1.55	24.8	40.5	0.61	0.94	39.5	4.91	0.0	0.094
							5.00		0.094
							5.04		0.096
12.10	1.47	24.8	40.4	0.62	0.85	41.8	4.75	0.0	0.089
							4.80		0.090
							4.87		0.094
10.20	1.33	22.7	40.2	0.57	0.76	42.5	4.80	0.0	0.084
							4.83		0.089
							4.87		0.092
8.41	1.22	21.7	40.3	0.54	0.68	44.0	4.66	0.0	0.083
							4.75		0.089
							4.83		0.090
6.85	1.10	21.1	40.5	0.52	0.58	47.5	4.41	0.0	0.080
							4.45		0.085
							4.58		0.086
3.44	0.78	18.9	41.3	0.46	0.32	59.0	4.12	0.0	0.075
							4.16		0.076
							4.29		0.075
1.38	0.49	21.9	60.4	0.36	0.13	74.0	3.71	0.0	0.067
							3.79		0.070
							3.96		0.066
0.58	0.31	16.2	60.4	0.27	0.04	85.8	3.00	0.0	0.060
							3.16		0.061
							3.25		0.056
0.26	0.21	12.0	60.4	0.20	0.01	95.5	2.29	0.0	0.054
							2.42		0.053
							2.58		0.050

Test No.: 26(Cont'd) Inlet: 4-Ft Special Date: Sept 9, 1971.

Long. Slope: 8 % Swale Slope: 48:1 Back Slope: 1/8:1

Remarks: Depth taken at toe of curb. Spread onto back slope less than 0.05 ft.

SYMBOLS

ΔH : Pressure-head drop across the orifice (ft. of water)

Q_1 : Channel discharge (cfs)

Q_2 : Discharge intercepted (cfs)

$Q_3 = Q_1 - Q_2$: Carryover (cfs)

V : Volume of water intercepted (ft.³)

T: Time (sec.)

η : Efficiency ($Q_2/Q_1 \times 100\%$)

B: Top width of channel (ft.)*

D: Depth of channel (ft.)*

*Measurements taken at stations 1 ft., 2 ft. and 3 ft. upstream from the start of the inlet grating.

ΔH	Q_1	V	T	Q_2	Q_3	η	B (Swale)	B (Back)	D
0.042	0.08			0.08	0.00	100.0	1.46	0.0	0.039
							1.58		0.038
							1.67		0.034

Test No.: 27 Inlet: 6-Ft Special Date: Sept 8, 1971.

Long. Slope: 8 % Swale Slope: 48:1 Back Slope: 1/8:1

Remarks: Depth taken at toe of curb. Spread onto back slope less than 0.05 ft.

SYMBOLS

ΔH : Pressure-head drop across the orifice (ft. of water)

Q_1 : Channel discharge (cfs)

Q_2 : Discharge intercepted (cfs)

$Q_3 = Q_1 - Q_2$: Carryover (cfs)

\forall : Volume of water intercepted (ft.³)

T: Time (sec.)

η : Efficiency ($Q_2/Q_1 \times 100\%$)

B: Top width of channel (ft.)*

D: Depth of channel (ft.)*

* Measurements taken at stations 1 ft., 2 ft. and 3 ft. upstream from the start of the inlet grating.

ΔH	Q_1	\forall	T	Q_2	Q_3	η	B (Swale)	B (Back)	D
13.78	1.56	26.0	40.3	0.65	0.91	41.3	4.95	0.0	0.089
							5.04		0.085
11.90	1.45	25.1	40.4	0.62	0.83	42.9	5.08		0.092
							4.87	0.0	0.083
							4.91		0.081
10.12	1.33	25.2	40.6	0.62	0.71	46.5	5.04		0.089
							4.79	0.0	0.085
							4.83		0.085
8.48	1.22	24.2	40.4	0.60	0.62	49.2	4.91		0.088
							4.75	0.0	0.084
							4.84		0.084
6.89	1.10	22.5	41.4	0.55	0.55	49.5	4.87		0.086
							4.50	0.0	0.082
							4.54		0.085
5.30	0.96	21.2	40.7	0.52	0.44	54.2	4.58		0.085
							4.33	0.0	0.079
							4.41		0.078
3.46	0.78	19.3	40.3	0.48	0.30	61.5	4.50		0.079
							4.12	0.0	0.066
							4.16		0.073
1.76	0.55	16.2	40.4	0.40	0.15	73.0	4.25		0.070
							3.92	0.0	0.068
							4.00		0.068
1.30	0.48	23.0	61.6	0.37	0.11	77.7	4.00		0.065
							3.79	0.0	0.067
							3.88		0.066
0.99	0.42	20.5	60.5	0.34	0.08	81.8	3.92		0.065
							3.66	0.0	0.065

Test No.: 27(Cont'd) Inlet: 6-Ft Special Date: Sept 8, 1971.

Long. Slope: 8% Swale Slope: 48:1 Back Slope: 1/8:1

Remarks: Depth taken at toe of curb. Spread onto back slope less than 0.05 ft.

SYMBOLS

ΔH : Pressure-head drop across the orifice (ft. of water)

Q_1 : Channel discharge (cfs)

Q_2 : Discharge intercepted (cfs)

$Q_3 = Q_1 - Q_2$: Carryover (cfs)

\forall : Volume of water intercepted (ft.³)

T: Time (sec.)

η : Efficiency ($Q_2/Q_1 \times 100\%$)

B: Top width of channel (ft.)*

D: Depth of channel (ft.)*

* Measurements taken at stations 1 ft., 2 ft. and 3 ft. upstream from the start of the inlet grating.

ΔH	Q_1	\forall	T	Q_2	Q_3	η	B (Swale)	B (Back)	D
0.63	0.33	18.0	60.4	0.30	0.03	90.4	3.79	0.0	0.065
							3.83		0.060
							3.08		0.059
							3.16		0.059
0.08	0.11			0.11	0.00	100.0	3.25	0.0	0.059
							1.46		0.041
							1.67		0.041
							1.71		0.036

Test No.: 27 A Inlet: 6-Ft Special Date: Oct 18, 1971

Long. Slope: 8.0 % Swale Slope: 48:1 Back Slope: 1/8:1

Remarks: Depth taken at toe of curb. Spread onto back slope less than 0.05 ft.

SYMBOLS

ΔH : Pressure-head drop across the orifice (ft. of water)

Q_1 : Channel discharge (cfs)

Q_2 : Discharge intercepted (cfs)

$Q_3 = Q_1 - Q_2$: Carryover (cfs)

V : Volume of water intercepted (ft.³)

T: Time (sec.)

η : Efficiency ($Q_2/Q_1 \times 100\%$)

B: Top width of channel (ft.)*

D: Depth of channel (ft.)*

* Measurements taken at stations 1 ft., 2 ft. and 3 ft. upstream from the start of the inlet grating.

ΔH	Q_1	V	T	Q_2	Q_3	η	B (Swale)	B (Back)	D
3.70	0.80	31.0	60.6	0.51	0.29	63.8	3.75	0.0	0.073
							3.83		0.072
							3.96		0.075
1.78	0.55	26.1	60.9	0.43	0.12	78.0	3.21	0.0	0.070
							3.25		0.069
							3.25		0.076
1.32	0.48	23.4	61.0	0.38	0.10	80.6	3.08	0.0	0.066
							3.08		0.068
							3.08		0.066
1.04	0.42	21.4	60.5	0.35	0.07	84.2	2.88	0.0	0.066
							2.92		0.066
							2.96		0.065
0.78	0.36	19.1	60.3	0.32	0.04	87.5	2.63	0.0	0.062
							2.67		0.062
							2.75		0.065
0.52	0.30	15.9	60.1	0.27	0.03	89.6	2.38	0.0	0.057
							2.46		0.058
							2.50		0.059
0.35	0.24	13.0	60.4	0.22	0.02	89.0	2.12	0.0	0.054
							2.29		0.055
							2.38		0.055
0.15	0.15	15.0	100.4	0.15	0.00	100.0	1.88	0.0	0.045
							1.88		0.045
							1.92		0.045

Test No.: 28 Inlet: 4-Ft Special Date: August 25, 1971.

Long. Slope: 8% Swale Slope: 24:1 Back Slope: 1/8:1

Remarks: Depth taken at toe of curb. Spread onto back slope less than 0.05 ft.

SYMBOLS

- ΔH : Pressure-head drop across the orifice (ft. of water)
- Q_1 : Channel discharge (cfs)
- Q_2 : Discharge intercepted (cfs)
- $Q_3 = Q_1 - Q_2$: Carryover (cfs)
- \forall : Volume of water intercepted (ft.³)
- T: Time (sec.)
- η : Efficiency ($Q_2/Q_1 \times 100\%$)
- B: Top width of channel (ft.)*
- D: Depth of channel (ft.)*

* Measurements taken at stations 1 ft., 2 ft. and 3 ft. upstream from the start of the inlet grating.

ΔH	Q_1	\forall	T	Q_2	Q_3	η	B (Swale)	B (Back)	D
13.95	1.57	54.6	60.4	0.91	0.66	57.5	3.08	0.0	0.132
							3.29		0.132
12.25	1.48	51.4	60.4	0.85	0.63	57.5	3.42		0.132
							3.08	0.0	0.129
							3.16		0.130
10.16	1.33	33.1	40.1	0.83	0.50	62.0	3.25		0.131
							2.88	0.0	0.130
							3.00		0.127
8.60	1.23	33.3	40.5	0.83	0.40	67.0	3.21		0.126
							2.75	0.0	0.132
							2.83		0.126
6.85	1.10	32.2	40.5	0.80	0.30	72.1	3.04		0.124
							2.29	0.0	0.129
							2.42		0.126
5.15	0.95	29.7	40.5	0.74	0.21	77.4	2.58		0.121
							2.25	0.0	0.129
							2.33		0.126
3.41	0.77	25.6	40.4	0.63	0.14	82.2	2.54		0.120
							2.08	0.0	0.115
							2.04		0.110
2.47	0.65	23.3	40.6	0.57	0.08	88.2	2.25		0.113
							1.92	0.0	0.104
							1.92		0.104
1.77	0.55	19.9	40.3	0.50	0.05	89.9	1.96		0.105
							1.79	0.0	0.099
							1.79		0.099
							1.83		0.097

Test No.: 28(Cont'd) Inlet: 4-Ft Special Date: August 25, 1971

Long. Slope: 8% Swale Slope: 24:1 Back Slope: 1/8:1

Remarks: Depth taken at toe of curb. Spread onto back slope less than 0.05 ft.

SYMBOLS

ΔH : Pressure-head drop across the orifice (ft. of water)

Q_1 : Channel discharge (cfs)

Q_2 : Discharge intercepted (cfs)

$Q_3 = Q_1 - Q_2$: Carryover (cfs)

Ψ : Volume of water intercepted (ft.³)

T: Time (sec.)

η : Efficiency ($Q_2/Q_1 \times 100\%$)

B: Top width of channel (ft.)*

D: Depth of channel (ft.)*

* Measurements taken at stations 1 ft., 2 ft. and 3 ft. upstream from the start of the inlet grating.

ΔH	Q_1	Ψ	T	Q_2	Q_3	η	B (Swale)	B (Back)	D
0.27	0.21			0.21	0.00	100.0	1.42	0.0	0.054
							1.42		0.056
							1.38		0.056

Test No.: 28 A Inlet: 4-Ft Special Date: Oct 11, 1971

Long. Slope: 8.0 % Swale Slope: 24:1 Back Slope: 1/8:1

Remarks: Depth taken at toe of curb. Spread onto back slope less than 0.05 ft.

SYMBOLS

ΔH : Pressure-head drop across the orifice (ft. of water)

Q_1 : Channel discharge (cfs)

Q_2 : Discharge intercepted (cfs)

$Q_3 = Q_1 - Q_2$: Carryover (cfs)

\forall : Volume of water intercepted (ft.³)

T: Time (sec.)

η : Efficiency ($Q_2/Q_1 \times 100\%$)

B: Top width of channel (ft.)*

D: Depth of channel (ft.)*

* Measurements taken at stations 1 ft., 2 ft. and 3 ft. upstream from the start of the inlet grating.

ΔH	Q_1	\forall	T	Q_2	Q_3	η	B (Swale)	B (Back)	D
4.03	0.83	41.6	60.4	0.69	0.14	83.2	2.16	0.0	0.118
							2.21		0.117
3.28	0.75	38.3	60.4	0.64	0.11	84.6	2.29	0.0	0.113
							2.13		0.115
							2.13		0.113
2.62	0.67	36.3	60.6	0.60	0.07	89.3	2.16	0.0	0.113
							2.00		0.107
							2.00		0.106
2.08	0.60	32.2	60.5	0.53	0.07	88.9	1.96	0.0	0.112
							1.92		0.104
							1.92		0.102
1.66	0.53	28.3	60.5	0.47	0.06	88.5	1.92	0.0	0.105
							1.87		0.096
							1.87		0.099
1.40	0.49	26.4	60.4	0.44	0.05	89.2	1.87	0.0	0.102
							1.83		0.091
							1.83		0.095
0.99	0.41	22.7	60.4	0.38	0.03	91.7	1.79	0.0	0.097
							1.79		0.081
							1.79		0.085
0.58	0.32	17.9	60.4	0.30	0.02	94.1	1.75	0.0	0.089
							1.75		0.068
							1.75		0.071
0.28	0.22	13.1	60.4	0.22	0.00	100.0	1.71	0.0	0.075
							1.58		0.055
							1.63		0.056
							1.58		0.059

Test No.: 28 B Inlet: 4-Ft Special Date: Oct 15, 1971.

Long. Slope: 8 % Swale Slope: 24:1 Back Slope: 1/8:1

Remarks: Depth taken at toe of curb. Spread onto back slope less than 0.05 ft.

SYMBOLS

ΔH : Pressure-head drop across the orifice (ft. of water)

Q_1 : Channel discharge (cfs)

Q_2 : Discharge intercepted (cfs)

$Q_3 = Q_1 - Q_2$: Carryover (cfs)

\forall : Volume of water intercepted (ft.³)

T: Time (sec.)

η : Efficiency ($Q_2/Q_1 \times 100\%$)

B: Top width of channel (ft.)*

D: Depth of channel (ft.)*

* Measurements taken at stations 1 ft., 2 ft. and 3 ft. upstream from the start of the inlet grating.

ΔH	Q_1	\forall	T	Q_2	Q_3	η	B (Swale)	B (Back)	D
11.70	1.42	49.7	60.8	0.82	0.60	57.5	3.08	0.0	0.119
							3.12		0.125
10.09	1.38	48.7	60.7	0.80	0.58	58.1	3.12	0.0	0.123
							2.96		0.121
							3.00		0.123
8.48	1.21	47.4	60.8	0.78	0.43	64.3	3.04	0.0	0.117
							2.75		0.119
							2.83		0.124
7.12	1.11	46.0	60.4	0.76	0.35	68.5	2.91	0.0	0.115
							2.58		0.119
							2.75		0.123
5.10	0.94	43.0	60.9	0.71	0.23	75.1	2.83	0.0	0.114
							2.33		0.118
							2.42		0.115
3.52	0.78	39.3	60.3	0.65	0.13	83.5	2.58	0.0	0.113
							2.08		0.114
							2.17		0.113
2.76	0.69	36.2	60.7	0.60	0.09	86.4	2.25	0.0	0.112
							2.00		0.108
							2.04		0.109
1.97	0.58	31.9	60.3	0.53	0.05	91.2	2.08	0.0	0.110
							1.83		0.101
							1.83		0.102
1.59	0.52	28.2	60.4	0.47	0.05	89.9	1.83	0.0	0.107
							1.79		0.095
							1.79		0.099
							1.75		0.100

Test No. 28 B Cont'd Inlet: 4-Ft Special Date: Oct 15, 1971.

Long. Slope: 8 % Swale Slope: 24:1 Back Slope: 1/8:1

Remarks: Depth taken at toe of curb. Spread onto back slope less than 0.05ft.

SYMBOLS

ΔH : Pressure-head drop across the orifice (ft. of water)

Q_1 : Channel discharge (cfs)

Q_2 : Discharge intercepted (cfs)

$Q_3 = Q_1 - Q_2$: Carryover (cfs)

Ψ : Volume of water intercepted (ft.³)

T: Time (sec.)

η : Efficiency ($Q_2/Q_1 \times 100\%$)

B: Top width of channel (ft.)*

D: Depth of channel (ft.)*

* Measurements taken at stations 1 ft., 2 ft. and 3 ft. upstream from the start of the inlet grating.

ΔH	Q_1	Ψ	T	Q_2	Q_3	η	B (Swale)	B (Back)	D
1.34	0.48	25.6	60.6	0.42	0.06	87.8	1.71	0.0	0.089
							1.71		0.094
0.88	0.39	21.2	60.2	0.35	0.04	91.5	1.67	0.0	0.097
							1.71		0.077
0.55	0.31	17.1	61.0	0.28	0.03	91.8	1.67	0.0	0.082
							1.62		0.086
							1.71		0.064
							1.67		0.070
							1.67		0.073

Test No.: 29 Inlet: 6-Ft Special Date: August 26, 1971.

Long. Slope: 8% Swale Slope: 24:1 Back Slope: 1/8:1

Remarks: Depth taken at toe of curb. Spread onto back slope less than 0.05 ft.

SYMBOLS

- ΔH : Pressure-head drop across the orifice (ft. of water)
- Q_1 : Channel discharge (cfs)
- Q_2 : Discharge intercepted (cfs)
- $Q_3 = Q_1 - Q_2$: Carryover (cfs)
- Ψ : Volume of water intercepted (ft.³)
- T: Time (sec.)
- η : Efficiency ($Q_2/Q_1 \times 100\%$)
- B: Top width of channel (ft.)*
- D: Depth of channel (ft.)*

* Measurements taken at stations 1 ft., 2 ft. and 3 ft. upstream from the start of the inlet grating.

ΔH	Q_1	Ψ	T	Q_2	Q_3	η	B (Swale)	B (Back)	D
13.72	1.57	43.1	40.3	1.07	0.50	68.1	3.17	0.0	0.135
							3.42		0.134
11.82	1.44	41.5	40.5	1.03	0.41	71.3	3.58	0.0	0.132
							3.08		0.133
10.28	1.33	39.8	40.5	0.99	0.34	74.0	3.25	0.0	0.131
							3.37		0.132
8.45	1.22	38.0	40.3	0.94	0.28	77.2	3.00	0.0	0.131
							3.08		0.129
6.78	1.09	36.1	40.3	0.90	0.19	82.0	3.25	0.0	0.131
							2.79		0.131
5.14	0.95	32.9	40.2	0.82	0.13	86.5	2.96	0.0	0.129
							3.08		0.127
3.48	0.78	28.0	40.5	0.69	0.09	88.4	2.54	0.0	0.131
							2.66		0.128
2.78	0.69	24.8	40.4	0.62	0.07	89.0	2.87	0.0	0.125
							2.29		0.126
2.08	0.60	21.6	40.5	0.54	0.06	89.0	2.42	0.0	0.125
							2.58		0.121
							2.08	0.0	0.115
							2.12		0.116
							2.29		0.118
							1.96	0.0	0.110
							2.00		0.112
							2.08		0.110
							1.83	0.0	0.103
							1.88		0.106
							1.88		0.105

Test No.: 29(Cont'd) Inlet: 6-Ft Special Date: August 26, 1971.

Long. Slope: 8 % Swale Slope: 24:1 Back Slope: 1/8:1

Remarks: Depth taken at toe of divisor. Spread onto back slope less than 0.05 ft.

SYMBOLS

- ΔH : Pressure-head drop across the orifice (ft. of water)
- Q_1 : Channel discharge (cfs)
- Q_2 : Discharge intercepted (cfs)
- $Q_3 = Q_1 - Q_2$: Carryover (cfs)
- \forall : Volume of water intercepted (ft.³)
- T: Time (sec.)
- η : Efficiency ($Q_2/Q_1 \times 100\%$)
- B: Top width of channel (ft.)*
- D: Depth of channel (ft.)*

* Measurements taken at stations 1 ft., 2 ft. and 3 ft. upstream from the start of the inlet grating.

ΔH	Q_1	\forall	T	Q_2	Q_3	η	B (Swale)	B (Back)	D
0.27	0.21			0.21	0.00	100.0	1.42	0.0	0.054
							1.42		0.057
1.42	0.50	27.4	60.4	0.46	0.04	91.1	1.42		0.060
							1.71	0.0	0.095
							1.67		0.096
0.68	0.34	19.3	60.4	0.32	0.02	93.7	1.63		0.100
							1.63	0.0	0.076
							1.63		0.076
							1.58		0.078

Test No.: 29 A Inlet: 6-Ft Special Date: August 26, 1971.

Long. Slope: 8 % Swale Slope: 24:1 Back Slope: 1/8:1

Remarks: Depth taken at toe of curb. Spread onto back slope less than 0.05 ft.

SYMBOLS

ΔH : Pressure-head drop across the orifice (ft. of water)

Q_1 : Channel discharge (cfs)

Q_2 : Discharge intercepted (cfs)

$Q_3 = Q_1 - Q_2$: Carryover (cfs)

\forall : Volume of water intercepted (ft.³)

T: Time (sec.)

η : Efficiency ($Q_2/Q_1 \times 100\%$)

B: Top width of channel (ft.)*

D: Depth of channel (ft.)*

* Measurements taken at stations 1 ft., 2 ft. and 3 ft. upstream from the start of the inlet grating.

ΔH	Q_1	\forall	T	Q_2	Q_3	η	B (Swale)	B (Back)	D
14.13	1.58	41.4	40.6	1.02	0.56	64.4	3.12	0.0	0.133
							3.33		0.137
							3.42		0.132
11.90	1.44	40.9	40.4	1.01	0.43	70.5	3.00	0.0	0.133
							3.21		0.128
							3.33		0.131
10.15	1.34	38.1	40.4	0.95	0.39	70.5	2.87	0.0	0.131
							3.00		0.131
							3.21		0.129
8.45	1.22	37.8	40.3	0.94	0.28	76.9	2.63	0.0	0.129
							2.87		0.128
							3.00		0.131
6.80	1.10	35.5	40.4	0.88	0.22	80.0	2.46	0.0	0.126
							2.63		0.131
							2.79		0.129
4.91	0.93	32.7	40.5	0.81	0.12	87.0	2.25	0.0	0.123
							2.38		0.125
							2.54		0.127
3.46	0.78	40.6	60.3	0.68	0.10	86.5	1.96	0.0	0.121
							2.04		0.115
							2.25		0.116
2.70	0.68	37.1	60.5	0.62	0.06	90.3	1.88	0.0	0.119
							1.92		0.110
							1.96		0.111
2.06	0.59	33.0	60.4	0.55	0.04	92.7	1.79	0.0	0.111
							1.79		0.102
							1.79		0.104

Test No.: 29 A Cont'd inlet: 6-Ft Special Date: August 26, 1971.

Long. Slope: 8 % Swale Slope: 24:1 Back Slope: 1/8:1

Remarks: Depth taken at toe of curb. Spread onto back slope less than 0.05 ft.

SYMBOLS

- ΔH : Pressure-head drop across the orifice (ft. of water)
- Q_1 : Channel discharge (cfs)
- Q_2 : Discharge intercepted (cfs)
- $Q_3 = Q_1 - Q_2$: Carryover (cfs)
- Ψ : Volume of water intercepted (ft.³)
- T: Time (sec.)
- η : Efficiency ($Q_2/Q_1 \times 100\%$)
- B: Top width of channel (ft.)*
- D: Depth of channel (ft.)*

* Measurements taken at stations 1 ft., 2 ft. and 3 ft. upstream from the start of the inlet grating.

ΔH	Q_1	Ψ	T	Q_2	Q_3	η	B (Swale)	B (Back)	D
1.27	0.47	26.0	60.4	0.43	0.04	91.7	1.75	0.0	0.093
							1.75		0.094
0.62	0.32	18.6	60.5	0.31	0.01	95.4	1.75		0.096
							1.67	0.0	0.073
							1.63		0.076
0.23	0.20			0.20	0.00	100.0	1.63		0.078
							1.50	0.0	0.057
							1.50		0.062
							1.46		0.063

Test No.: 29 B Inlet: 6-Ft Special Date: Oct 4, 1971.

Long. Slope: 8 % Swale Slope: 24:1 Back Slope: 1/8:1

Remarks: Depth taken at toe of curb. Spread onto back slope less than 0.05 ft.

SYMBOLS

ΔH : Pressure-head drop across the orifice (ft. of water)

Q_1 : Channel discharge (cfs)

Q_2 : Discharge intercepted (cfs)

$Q_3 = Q_1 - Q_2$: Carryover (cfs)

Ψ : Volume of water intercepted (ft.³)

T: Time (sec.)

η : Efficiency ($Q_2/Q_1 \times 100\%$)

B: Top width of channel (ft.)*

D: Depth of channel (ft.)*

* Measurements taken at stations 1 ft., 2 ft. and 3 ft. upstream from the start of the inlet grating.

ΔH	Q_1	Ψ	T	Q_2	Q_3	η	B (Swale)	B (Back)	D
14.60	1.60	64.0	61.2	1.05	0.55	65.4	3.50	0.0	0.128
							3.58		0.126
11.70	1.43	60.9	60.4	1.01	0.42	70.5	3.66		0.131
							3.16	0.0	0.125
							3.33		0.125
10.05	1.32	57.4	60.2	0.95	0.37	72.1	3.42		0.125
							2.96	0.0	0.124
							3.00		0.124
8.25	1.21	56.7	60.7	0.93	0.28	77.1	3.12		0.120
							2.75	0.0	0.122
							2.87		0.123
6.90	1.10	53.6	60.3	0.89	0.21	81.0	2.92		0.118
							2.42	0.0	0.119
							2.54		0.121
4.97	0.93	47.5	61.0	0.78	0.15	83.5	2.66		0.118
							2.25	0.0	0.120
							2.37		0.118
3.41	0.77	40.5	60.7	0.67	0.10	86.5	2.54		0.114
							2.13	0.0	0.116
							2.13		0.116
1.71	0.54	29.0	60.8	0.48	0.06	88.4	2.25		0.113
							1.83	0.0	0.099
							1.83		0.100
1.07	0.43	23.4	60.7	0.39	0.04	89.6	1.75		0.105
							1.79	0.0	0.085
							1.75		0.089
0.20	0.18			0.18	0.00	100.0	1.71		0.092
							1.54	0.0	0.051
							1.54		0.054
							1.54		0.053

Test No.: 29 C Inlet: 6-Ft Special Date: Oct 11, 1971

Long. Slope: 8.0 % Swale Slope: 24:1 Back Slope: 1/8:1

Remarks: Depth taken at toe of curb. Spread onto back slope less than 0.05 ft.

SYMBOLS

ΔH : Pressure-head drop across the orifice (ft. of water)

Q_1 : Channel discharge (cfs)

Q_2 : Discharge intercepted (cfs)

$Q_3 = Q_1 - Q_2$: Carryover (cfs)

Ψ : Volume of water intercepted (ft.³)

T: Time (sec.)

η : Efficiency ($Q_2/Q_1 \times 100\%$)

B: Top width of channel (ft.)*

D: Depth of channel (ft.)*

* Measurements taken at stations 1 ft., 2 ft. and 3 ft. upstream from the start of the inlet grating.

ΔH	Q_1	Ψ	T	Q_2	Q_3	η	B (Swale)	B (Back)	D
3.54	0.78	42.0	60.4	0.70	0.08	89.4	2.00	0.0	0.115
							2.04		0.115
2.78	0.69	35.2	60.5	0.58	0.11	84.5	2.12	0.0	0.113
							2.00		0.110
2.00	0.59	32.8	60.3	0.55	0.04	92.3	2.00	0.0	0.110
							2.08		0.111
1.76	0.55	30.2	60.4	0.50	0.05	91.0	1.87	0.0	0.103
							1.87		0.103
1.44	0.50	27.5	60.2	0.46	0.04	91.4	1.87	0.0	0.108
							1.83		0.098
1.02	0.42	22.9	60.4	0.38	0.04	91.1	1.83	0.0	0.100
							1.79		0.103
0.68	0.34	19.2	60.2	0.32	0.02	93.8	1.83	0.0	0.091
							1.79		0.096
0.47	0.28	16.7	60.3	0.28	0.00	98.9	1.75	0.0	0.097
							1.75		0.082
0.15	0.15			0.15	0.00	100.0	1.75	0.0	0.086
							1.75		0.090
							1.71	0.0	0.071
							1.71		0.076
							1.67	0.0	0.078
							1.67		0.064
							1.67	0.0	0.065
							1.67		0.070
							1.50	0.0	0.050
							1.54		0.052
							1.54		0.050

Test No.: 30 Inlet: 4-Ft Special Date: Sept 20, 1971.

Long. Slope: 8% Swale Slope: 16:1 Back Slope: 1/8:1

Remarks: Depth taken at toe of curb. Spread onto back slope less than 0.05 ft.

SYMBOLS

ΔH : Pressure-head drop across the orifice (ft. of water)

Q_1 : Channel discharge (cfs)

Q_2 : Discharge intercepted (cfs)

$Q_3 = Q_1 - Q_2$: Carryover (cfs)

V : Volume of water intercepted (ft.³)

T: Time (sec.)

η : Efficiency ($Q_2/Q_1 \times 100\%$)

B: Top width of channel (ft.)*

D: Depth of channel (ft.)*

* Measurements taken at stations 1 ft., 2 ft. and 3 ft. upstream from the start of the inlet grating.

ΔH	Q_1	V	T	Q_2	Q_3	η	B (Swale)	B (Back)	D
14.17	1.59	40.2	40.5	0.99	0.60	62.3	2.37	0.0	0.176
							2.33		0.174
12.00	1.45	38.8	40.5	0.96	0.49	66.2	2.37		0.163
							2.33	0.0	0.174
							2.33		0.173
10.18	1.33	35.9	40.4	0.89	0.44	67.0	2.29		0.166
							2.25	0.0	0.169
							2.25		0.171
8.28	1.21	33.1	40.1	0.83	0.38	68.0	2.21		0.165
							2.16	0.0	0.160
							2.16		0.168
6.64	1.08	30.9	40.3	0.77	0.31	71.0	2.08		0.164
							2.08	0.0	0.154
							2.12		0.157
5.31	0.96	29.2	40.4	0.72	0.24	75.4	2.00		0.161
							2.00	0.0	0.145
							2.00		0.149
3.40	0.77	25.8	40.4	0.64	0.13	83.0	1.96		0.154
							1.92	0.0	0.126
							1.88		0.132
1.75	0.55	29.3	60.4	0.49	0.06	88.3	1.88		0.135
							1.79	0.0	0.098
							1.79		0.103
0.90	0.39	22.4	60.6	0.37	0.02	94.7	1.75		0.109
							1.71	0.0	0.078
							1.71		0.081
0.34	0.24			0.24	0.00	100.0	1.71		0.085
							1.50	0.0	0.071
							1.54		0.067
							1.54		0.063

Test No.: 30 A Inlet: 4-Ft Special Date: Oct 12, 1971

Long. Slope: 8.0 % Swale Slope: 16:1 Back Slope: 1/8:1

Remarks: Depth taken at toe of curb. Spread onto back slope less than 0.05 ft.

SYMBOLS

ΔH : Pressure-head drop across the orifice (ft. of water)

Q_1 : Channel discharge (cfs)

Q_2 : Discharge intercepted (cfs)

$Q_3 = Q_1 - Q_2$: Carryover (cfs)

Ψ : Volume of water intercepted (ft.³)

T: Time (sec.)

η : Efficiency ($Q_2/Q_1 \times 100\%$)

B: Top width of channel (ft.)*

D: Depth of channel (ft.)*

* Measurements taken at stations 1 ft., 2 ft. and 3 ft. upstream from the start of the inlet grating.

ΔH	Q_1	Ψ	T	Q_2	Q_3	η	B (Swale)	B (Back)	D
4.75	0.91	45.7	60.3	0.76	0.15	83.2	1.96	0.0	0.138
							1.96		0.140
3.40	0.76	39.6	60.9	0.65	0.11	85.6	1.96		0.137
							1.87	0.0	0.124
							1.87		0.130
2.75	0.69	36.5	60.2	0.61	0.08	87.8	1.87		0.128
							1.83	0.0	0.119
							1.83		0.121
1.99	0.58	31.5	61.2	0.52	0.06	88.7	1.79		0.124
							1.75	0.0	0.104
							1.75		0.109
1.63	0.53	30.0	61.2	0.49	0.04	92.4	1.75		0.114
							1.71	0.0	0.096
							1.71		0.102
1.30	0.47	27.4	60.7	0.45	0.02	96.0	1.66		0.106
							1.71	0.0	0.089
							1.71		0.093
1.05	0.42	24.6	61.2	0.40	0.02	95.8	1.66		0.099
							1.71	0.0	0.080
							1.71		0.085
0.67	0.34	20.4	61.0	0.33	0.01	99.6	1.66		0.091
							1.62	0.0	0.072
							1.66		0.074
0.20	0.18			0.18	0.00	100.0	1.62		0.076
							1.33	0.0	0.069
							1.42		0.064
							1.42		0.059

Test No.: 31 Inlet: 6-Ft Special Date: Sept 16, 1971

Long. Slope: 8.0 % Swale Slope: 16:1 Back Slope: 1/8:1

Remarks: Depth taken at toe of curb. Spread onto back slope less than 0.05 ft.

SYMBOLS

ΔH : Pressure-head drop across the orifice (ft. of water)

Q_1 : Channel discharge (cfs)

Q_2 : Discharge intercepted (cfs)

$Q_3 = Q_1 - Q_2$: Carryover (cfs)

\forall : Volume of water intercepted (ft.³)

T: Time (sec.)

η : Efficiency ($Q_2/Q_1 \times 100\%$)

B: Top width of channel (ft.)*

D: Depth of channel (ft.)*

* Measurements taken at stations 1 ft., 2 ft. and 3 ft. upstream from the start of the inlet grating.

ΔH	Q_1	\forall	T	Q_2	Q_3	η	B (Swale)	B (Back)	D
14.37	1.60	49.8	41.3	1.21	0.39	75.4	2.33	0.0	0.186
							2.33		0.174
12.08	1.46	45.8	40.4	1.14	0.32	77.9	2.46		0.164
							2.21	0.0	0.188
							2.21		0.176
10.28	1.34	41.8	40.4	1.04	0.30	77.3	2.25		0.159
							2.16	0.0	0.179
							2.16		0.180
8.53	1.22	40.0	41.3	0.97	0.25	79.5	2.13		0.160
							2.08	0.0	0.171
							2.08		0.182
6.80	1.10	36.4	40.5	0.90	0.20	81.5	2.08		0.164
							2.04	0.0	0.159
							2.00		0.170
4.85	0.92	33.5	41.3	0.81	0.11	88.1	1.96		0.166
							1.96	0.0	0.143
							1.92		0.150
3.49	0.78	27.1	40.4	0.67	0.11	86.1	1.92		0.158
							1.92	0.0	0.126
							1.87		0.135
1.73	0.55	30.5	60.5	0.51	0.04	91.7	1.83		0.139
							1.79	0.0	0.095
							1.79		0.102
1.42	0.50	27.2	60.4	0.45	0.05	91.0	1.71		0.107
							1.79	0.0	0.088
							1.79		0.094
							1.75		0.099

Test No.: 31 Cont'd Inlet: 6-Ft Special Date: Sept 16, 1971

Long. Slope: 8.0 % Swale Slope: 16:1 Back Slope: 1/8:1

Remarks: Depth taken at toe of curb. Spread onto back slope less than 0.05 ft.

SYMBOLS

ΔH : Pressure-head drop across the orifice (ft. of water)

Q_1 : Channel discharge (cfs)

Q_2 : Discharge intercepted (cfs)

$Q_3 = Q_1 - Q_2$: Carryover (cfs)

V : Volume of water intercepted (ft.³)

T: Time (sec.)

η : Efficiency ($Q_2/Q_1 \times 100\%$)

B: Top width of channel (ft.)*

D: Depth of channel (ft.)*

* Measurements taken at stations 1 ft., 2 ft. and 3 ft. upstream from the start of the inlet grating.

ΔH	Q_1	V	T	Q_2	Q_3	η	B (Swale)	B (Back)	D
0.52	0.30			0.30	0.00	100.0	1.62	0.0	0.069
							1.62		0.070
							1.62		0.069

Test No.: 31 A Inlet: 6-Ft Special Date: Oct 13, 1971

Long. Slope: 8.0 % Swale Slope: 16:1 Back Slope: 1/8:1

Remarks: Depth taken at toe of curb. Spread onto back slope less than 0.05 ft.

SYMBOLS

ΔH : Pressure-head drop across the orifice (ft. of water)

Q_1 : Channel discharge (cfs)

Q_2 : Discharge intercepted (cfs)

$Q_3 = Q_1 - Q_2$: Carryover (cfs)

\forall : Volume of water intercepted (ft.³)

T: Time (sec.)

η : Efficiency ($Q_2/Q_1 \times 100\%$)

B: Top width of channel (ft.)*

D: Depth of channel (ft.)*

* Measurements taken at stations 1 ft., 2 ft. and 3 ft. upstream from the start of the inlet grating.

ΔH	Q_1	\forall	T	Q_2	Q_3	η	B (Swale)	B (Back)	D
4.83	0.92	49.1	60.5	0.81	0.11	88.2	1.96	0.0	0.136
							1.96		0.137
3.51	0.78	42.0	60.4	0.70	0.08	89.2	1.96	0.0	0.140
							1.83	0.0	0.127
							1.83		0.132
2.73	0.69	37.4	60.4	0.62	0.07	90.4	1.83	0.0	0.130
							1.79	0.0	0.119
							1.79		0.121
1.95	0.58	31.4	60.5	0.52	0.06	89.5	1.79	0.0	0.124
							1.75	0.0	0.103
							1.75		0.111
1.59	0.52	29.5	60.5	0.49	0.03	93.7	1.75	0.0	0.115
							1.75	0.0	0.096
							1.75		0.103
1.33	0.48	27.6	60.5	0.46	0.02	96.0	1.71	0.0	0.106
							1.75	0.0	0.090
							1.75		0.093
1.02	0.42	24.5	60.5	0.41	0.01	97.2	1.71	0.0	0.098
							1.71	0.0	0.079
							1.71		0.084
0.70	0.34	35.2	100.4	0.34	0.00	100.0	1.66	0.0	0.090
							1.66	0.0	0.073
							1.66		0.075
							1.62		0.077

Test No.: 32 Inlet: 4-Ft Special Date: Sept 27, 1971

Long. Slope: 8.0 % Swale Slope: 12:1 Back Slope: 1/8:1

Remarks: Depth taken at toe of curb. Spread onto back slope less than 0.05 ft.

SYMBOLS

ΔH : Pressure-head drop across the orifice (ft. of water)

Q_1 : Channel discharge (cfs)

Q_2 : Discharge intercepted (cfs)

$Q_3 = Q_1 - Q_2$: Carryover (cfs)

\forall : Volume of water intercepted (ft.³)

T: Time (sec.)

η : Efficiency ($Q_2/Q_1 \times 100\%$)

B: Top width of channel (ft.)*

D: Depth of channel (ft.)*

* Measurements taken at stations 1 ft., 2 ft. and 3 ft. upstream from the start of the inlet grating.

ΔH	Q_1	\forall	T	Q_2	Q_3	η	B (Swale)	B (Back)	D
13.62	1.56	40.4	40.5	1.00	0.56	63.9	2.08	0.0	0.197
							2.08		0.206
11.76	1.44	39.2	40.4	0.97	0.47	67.5	2.12		0.193
							2.04	0.0	0.188
							2.04		0.197
10.25	1.34	35.8	40.4	0.89	0.45	66.1	2.04		0.194
							2.00	0.0	0.181
							2.00		0.187
8.51	1.22	34.4	40.5	0.85	0.37	69.7	2.00		0.193
							1.92	0.0	0.172
							1.92		0.180
6.75	1.09	32.0	40.3	0.79	0.30	72.8	1.92		0.182
							1.87	0.0	0.155
							1.87		0.165
4.88	0.92	29.3	40.4	0.73	0.19	79.0	1.87		0.173
							1.83	0.0	0.136
							1.79		0.145
3.50	0.78	27.0	40.6	0.67	0.11	85.2	1.79		0.155
							1.79	0.0	0.120
							1.79		0.124
1.88	0.57	32.9	60.4	0.55	0.02	95.7	1.75		0.133
							1.71	0.0	0.098
							1.71		0.101
0.99	0.42			0.42	0.00	100.0	1.71		0.104
							1.50	0.0	0.102
							1.54		0.092
							1.54		0.087

Test No.: 32 A Inlet: 4-Ft Special Date: Oct 14, 1971

Long. Slope: 8.0 % Swale Slope: 12:1 Back Slope: 1/8:1

Remarks: Depth taken at toe of curb. Spread onto back slope less than 0.05 ft.

SYMBOLS

ΔH : Pressure-head drop across the orifice (ft. of water)

Q_1 : Channel discharge (cfs)

Q_2 : Discharge intercepted (cfs)

$Q_3 = Q_1 - Q_2$: Carryover (cfs)

Ψ : Volume of water intercepted (ft.³)

T: Time (sec.)

η : Efficiency ($Q_2/Q_1 \times 100\%$)

B: Top width of channel (ft.)*

D: Depth of channel (ft.)*

* Measurements taken at stations 1 ft., 2 ft. and 3 ft. upstream from the start of the inlet grating.

ΔH	Q_1	Ψ	T	Q_2	Q_3	η	B (Swale)	B (Back)	D
5.85	1.00	47.0	60.7	0.78	0.22	77.5	1.83	0.0	0.145
							1.83		0.159
4.45	0.88	43.1	60.8	0.71	0.17	81.0	1.83	0.0	0.165
							1.83		0.131
							1.83		0.139
3.39	0.76	40.0	60.1	0.67	0.09	87.5	1.79	0.0	0.150
							1.83		0.123
							1.83		0.122
2.57	0.66	35.9	60.5	0.60	0.06	90.0	1.79	0.0	0.137
							1.79		0.108
							1.79		0.112
2.05	0.59	33.9	60.4	0.56	0.03	95.1	1.79	0.0	0.119
							1.79		0.103
							1.79		0.105
1.71	0.54	31.9	60.4	0.53	0.01	98.0	1.75	0.0	0.109
							1.75		0.101
							1.75		0.099
1.43	0.50	29.6	60.8	0.49	0.01	98.5	1.75		0.103

Test No: 33 Inlet: 6-Ft Special Date: Sept 28, 1971

Long. Slope: 8.0 % Swale Slope: 12:1 Back Slope: 1/8:1

Remarks: Depth taken at toe of curb. Spread onto back slope less than 0.05 ft.

SYMBOLS

ΔH : Pressure-head drop across the orifice (ft. of water)

Q_1 : Channel discharge (cfs)

Q_2 : Discharge intercepted (cfs)

$Q_3 = Q_1 - Q_2$: Carryover (cfs)

\forall : Volume of water intercepted (ft.³)

T: Time (sec.)

η : Efficiency ($Q_2/Q_1 \times 100\%$)

B: Top width of channel (ft.)*

D: Depth of channel (ft.)*

*Measurements taken at stations 1 ft., 2 ft. and 3 ft. upstream from the start of the inlet grating.

ΔH	Q_1	\forall	T	Q_2	Q_3	η	B (Swale)	B (Back)	D
13.75	1.56	72.8	60.6	1.20	0.36	77.0	2.08	0.0	0.199
							2.08		0.208
11.70	1.43	67.5	60.5	1.11	0.32	77.9	2.13		0.194
							2.08	0.0	0.189
							2.13		0.195
10.19	1.33	64.9	60.3	1.08	0.25	80.8	2.13		0.195
							2.00	0.0	0.183
							2.04		0.188
8.49	1.22	61.8	60.4	1.02	0.20	84.0	2.04		0.192
							1.92	0.0	0.172
							1.96		0.178
6.82	1.10	56.7	60.5	0.94	0.16	85.3	1.96		0.187
							1.92	0.0	0.158
							1.92		0.165
4.95	0.93	50.7	60.5	0.84	0.09	90.2	1.92		0.177
							1.83	0.0	0.136
							1.83		0.146
3.47	0.78	42.1	60.3	0.70	0.08	89.7	1.83		0.154
							1.79	0.0	0.120
							1.79		0.127
1.84	0.56	32.9	60.5	0.55	0.01	97.4	1.75		0.136
							1.67	0.0	0.102
							1.71		0.101
1.25	0.47			0.47	0.00	100.0	1.71		0.103
							1.54	0.0	0.099
							1.58		0.095
							1.58		0.093

Test No.: 33 A Inlet: 6-Ft Special Date: Oct 13, 1971

Long. Slope: 8.0 % Swale Slope: 12:1 Back Slope: 1/8:1

Remarks: Depth taken at toe of curb. Spread onto back slope less than 0.05 ft.

SYMBOLS

- ΔH : Pressure-head drop across the orifice (ft. of water)
- Q_1 : Channel discharge (cfs)
- Q_2 : Discharge intercepted (cfs)
- $Q_3 = Q_1 - Q_2$: Carryover (cfs)
- Ψ : Volume of water intercepted (ft.³)
- T: Time (sec.)
- η : Efficiency ($Q_2/Q_1 \times 100\%$)
- B: Top width of channel (ft.)*
- D: Depth of channel (ft.)*

* Measurements taken at stations 1 ft., 2 ft. and 3 ft. upstream from the start of the inlet grating.

ΔH	Q_1	Ψ	T	Q_2	Q_3	η	B (Swale)	B (Back)	D
4.79	0.91	50.2	60.5	0.83	0.08	91.3	1.83	0.0	0.134
							1.79		0.145
3.42	0.77	43.5	60.5	0.72	0.05	93.5	1.75		0.153
							1.83	0.0	0.123
							1.79		0.125
2.57	0.66	38.2	60.7	0.63	0.03	95.4	1.79		0.136
							1.79	0.0	0.110
							1.79		0.115
2.31	0.63	36.6	60.5	0.61	0.02	96.0	1.75		0.118
							1.75	0.0	0.105
							1.75		0.111
1.71	0.54	32.4	60.5	0.53	0.01	98.9	1.71		0.113
							1.62	0.0	0.099
							1.67		0.095
1.52	0.51			0.51	0.00	100.0	1.67		0.098

Test No.: 36 Inlet: 4-Ft Special Date: Nov 3, 1971

Long. Slope: 4.0 % Swale Slope: 48:1 Back Slope: 1/8:1

Remarks: Depth taken at toe of curb. Spread onto back slope less than 0.05 ft.

SYMBOLS

- ΔH : Pressure-head drop across the orifice (ft. of water) Ψ : Volume of water intercepted (ft.³)
 Q_1 : Channel discharge (cfs) T: Time (sec.)
 Q_2 : Discharge intercepted (cfs) η : Efficiency ($Q_2/Q_1 \times 100\%$)
 $Q_3 = Q_1 - Q_2$: Carryover (cfs) B: Top width of channel (ft.)*
D: Depth of channel (ft.)*

* Measurements taken at stations 1 ft., 2 ft. and 3 ft. upstream from the start of the inlet grating.

ΔH	Q_1	Ψ	T	Q_2	Q_3	η	B (Swale)	B (Back)	D
13.45	1.54	43.0	61.0	0.70	0.84	45.7	5.12	0.0	0.118
							5.25		0.117
							5.33		0.114
9.96	1.31	38.1	60.3	0.63	0.68	48.2	4.96	0.0	0.113
							5.12		0.109
							5.25		0.109
6.76	1.08	36.5	60.4	0.61	0.47	56.0	4.50	0.0	0.105
							4.70		0.108
							4.88		0.102
3.60	0.79	30.9	60.1	0.51	0.28	65.0	3.96	0.0	0.095
							4.16		0.097
							4.33		0.093
2.70	0.68	27.5	60.2	0.46	0.22	67.1	3.71	0.0	0.094
							3.92		0.092
							4.00		0.095
2.10	0.60	25.1	59.9	0.42	0.18	69.9	3.54	0.0	0.089
							3.75		0.090
							3.87		0.090
1.37	0.49	21.7	60.1	0.36	0.13	74.4	2.83	0.0	0.087
							3.16		0.084
							3.42		0.084
0.55	0.30	14.9	59.9	0.25	0.07	83.0	2.75	0.0	0.064
							2.83		0.060
							2.91		0.058
0.03	0.08			0.08	0.00	100.0	1.83	0.0	0.037
							1.92		0.040
							2.00		0.035

Test No.: 37 Inlet: 6-Ft Special Date: Nov 3, 1971
 Long. Slope: 4.0 % Swale Slope: 48:1 Back Slope: 1/8:1

Remarks: Depth taken at toe of curb. Spread onto back slope less than 0.05 ft.

SYMBOLS

- ΔH : Pressure-head drop across the orifice (ft. of water)
- Q_1 : Channel discharge (cfs)
- Q_2 : Discharge intercepted (cfs)
- $Q_3 = Q_1 - Q_2$: Carryover (cfs)
- Ψ : Volume of water intercepted (ft.³)
- T: Time (sec.)
- η : Efficiency ($Q_2/Q_1 \times 100\%$)
- B: Top width of channel (ft.)*
- D: Depth of channel (ft.)*

* Measurements taken at stations 1 ft., 2 ft. and 3 ft. upstream from the start of the inlet grating.

ΔH	Q_1	Ψ	T	Q_2	Q_3	η	B (Swale)	B (Back)	D
13.22	1.52	44.7	60.3	0.74	0.78	48.7	4.80	0.0	0.119
							4.91		0.122
							5.09		0.113
10.02	1.32	41.7	60.7	0.69	0.63	52.0	4.71	0.0	0.111
							4.83		0.112
							5.00		0.105
6.58	1.07	37.0	60.6	0.61	0.46	57.0	4.33	0.0	0.102
							4.50		0.103
							4.66		0.092
4.90	0.92	33.6	60.5	0.56	0.36	60.5	4.08	0.0	0.097
							4.25		0.096
							4.37		0.088
3.64	0.79	31.1	60.5	0.52	0.27	65.2	3.88	0.0	0.095
							4.04		0.095
							4.12		0.089
2.73	0.69	29.4	60.6	0.48	0.21	70.1	3.71	0.0	0.089
							3.84		0.090
							3.96		0.085
1.96	0.58	25.9	60.5	0.43	0.15	74.0	3.38	0.0	0.085
							3.67		0.088
							3.83		0.081
1.42	0.49	22.2	60.5	0.37	0.12	75.0	3.04	0.0	0.082
							3.04		0.080
							3.16		0.082
0.71	0.35	15.6	60.5	0.26	0.09	74.8	2.75	0.0	0.062
							2.75		0.059
							2.84		0.058

Test No: 37 Cont'd Inlet: 6-Ft Special Date: Nov 3, 1971

Long. Slope: 4.0 % Swale Slope: 48:1 Back Slope: 1/8:1

Remarks: Depth taken at toe of curb. Spread onto back slope less than 0.05 ft.

SYMBOLS

ΔH : Pressure-head drop across the orifice (ft. of water)

Q_1 : Channel discharge (cfs)

Q_2 : Discharge intercepted (cfs)

$Q_3 = Q_1 - Q_2$: Carryover (cfs)

\forall : Volume of water intercepted (ft.³)

T: Time (sec.)

η : Efficiency ($Q_2/Q_1 \times 100\%$)

B: Top width of channel (ft.)*

D: Depth of channel (ft.)*

* Measurements taken at stations 1 ft., 2 ft. and 3 ft. upstream from the start of the inlet grating.

ΔH	Q_1	\forall	T	Q_2	Q_3	η	B (Swale)	B (Back)	D
0.32	0.23	11.3	60.5	0.19	0.04	81.4	2.58	0.0	0.054
							2.54		0.051
0.08	0.12			0.12	0.00	100.0	2.54		0.050
							2.04	0.0	0.042
							2.08		0.040
							2.08		0.036

Test No.: 37 A Inlet: 6-Ft Special Date: Nov 5, 1971

Long. Slope: 4.0 % Swale Slope: 48:1 Back Slope: 1/8:1

Remarks: Depth taken at toe of curb. Spread onto back slope less than 0.05 ft.

SYMBOLS

ΔH : Pressure-head drop across the orifice (ft. of water)

Q_1 : Channel discharge (cfs)

Q_2 : Discharge intercepted (cfs)

$Q_3 = Q_1 - Q_2$: Carryover (cfs)

Ψ : Volume of water intercepted (ft.³)

T: Time (sec.)

η : Efficiency ($Q_2/Q_1 \times 100\%$)

B: Top width of channel (ft.)*

D: Depth of channel (ft.)*

* Measurements taken at stations 1 ft., 2 ft. and 3 ft. upstream from the start of the inlet grating.

ΔH	Q_1	Ψ	T	Q_2	Q_3	η	B (Swale)	B (Back)	D
1.03	0.43	19.9	60.5	0.33	0.10	76.3	2.75	0.0	0.080
							2.75		0.080
0.63	0.33	16.4	60.4	0.27	0.06	82.4	2.75		0.081
							2.63	0.0	0.074
							2.58		0.072
0.37	0.25	12.9	60.5	0.21	0.04	85.3	2.54		0.072
							2.58	0.0	0.061
							2.54		0.062
							2.46		0.062

Test No.: 38 Inlet: 4-Ft Special Date: Nov 8, 1971

Long. Slope: 4.0 % Swale Slope: 24:1 Back Slope: 1/8:1

Remarks: Depth taken at toe of curb. Spread onto back slope less than 0.05 ft.

SYMBOLS

ΔH : Pressure-head drop across the orifice (ft. of water)

Q_1 : Channel discharge (cfs)

Q_2 : Discharge intercepted (cfs)

$Q_3 = Q_1 - Q_2$: Carryover (cfs)

\forall : Volume of water intercepted (ft.³)

T: Time (sec.)

η : Efficiency ($Q_2/Q_1 \times 100\%$)

B: Top width of channel (ft.)*

D: Depth of channel (ft.)*

* Measurements taken at stations 1 ft., 2 ft. and 3 ft. upstream from the start of the inlet grating.

ΔH	Q_1	\forall	T	Q_2	Q_3	η	B (Swale)	B (Back)	D
13.96	1.56	62.3	61.0	1.02	0.54	65.5	3.66	0.0	0.163
							3.75		0.156
4.71	0.90	42.7	60.5	0.71	0.19	78.5	3.81	0.0	0.146
							2.83		0.146
							2.83		0.142
3.44	0.77	37.6	61.1	0.62	0.15	79.8	2.83	0.0	0.148
							2.75		0.129
							2.75		0.134
2.67	0.68	31.8	60.7	0.52	0.16	77.0	2.71	0.0	0.133
							2.67		0.111
							2.62		0.122
2.11	0.60	29.2	60.5	0.48	0.12	80.5	2.62	0.0	0.125
							2.62		0.104
							2.58		0.111
1.39	0.49	25.0	60.9	0.41	0.08	84.6	2.58	0.0	0.112
							2.50		0.092
							2.50		0.091
0.86	0.38	21.2	60.3	0.35	0.03	92.5	2.50	0.0	0.094
							2.38		0.079
							2.38		0.079
0.57	0.31	18.3	60.6	0.30	0.01	97.4	2.42	0.0	0.080
							2.21		0.079
							2.25		0.072
0.26	0.21			0.21	0.00	100.0	2.25	0.0	0.071
							1.79		0.077
							1.92		0.074
							1.96		0.067

Test No.: 39 Inlet: 6-Ft Special Date: Nov 8, 1971

Long. Slope: 4.0 % Swale Slope: 24:1 Back Slope: 1/8:1

Remarks: Depth taken at toe of curb. Spread onto back slope less than 0.05 ft.

SYMBOLS

ΔH : Pressure-head drop across the orifice (ft. of water)

Q_1 : Channel discharge (cfs)

Q_2 : Discharge intercepted (cfs)

$Q_3 = Q_1 - Q_2$: Carryover (cfs)

\forall : Volume of water intercepted (ft.³)

T: Time (sec.)

η : Efficiency ($Q_2/Q_1 \times 100\%$)

B: Top width of channel (ft.)*

D: Depth of channel (ft.)*

* Measurements taken at stations 1 ft., 2 ft. and 3 ft. upstream from the start of the inlet grating.

ΔH	Q_1	\forall	T	Q_2	Q_3	η	B (Swale)	B (Back)	D
3.45	0.77	37.9	60.5	0.63	0.14	81.5	2.75	0.0	0.124
							2.75		0.133
2.72	0.68	33.3	60.4	0.55	0.13	81.1	2.75	0.0	0.132
							2.67		0.111
							2.67		0.120
2.13	0.61	31.4	60.2	0.52	0.09	85.5	2.67	0.0	0.123
							2.58		0.103
							2.58		0.110
1.37	0.49	26.7	60.6	0.44	0.05	90.7	2.58	0.0	0.112
							2.50		0.090
							2.50		0.092
1.04	0.42	23.2	60.5	0.38	0.04	91.2	2.50	0.0	0.093
							2.42		0.083
							2.42		0.082
0.75	0.36	20.5	60.6	0.34	0.02	95.2	2.42	0.0	0.084
							2.29		0.077
							2.33		0.077
0.44	0.27			0.27	0.00	100.0	2.33	0.0	0.076
							2.00		0.079
							2.16		0.072
							2.21		0.068

Test No.: 40 Inlet: 4-Ft Special Date: Nov 9, 1971

Long. Slope: 4.0 % Swale Slope: 16:1 Back Slope: 1/8:1

Remarks: Depth taken at toe of curb. Spread onto back slope less than 0.05 ft.

SYMBOLS

ΔH : Pressure-head drop across the orifice (ft. of water)

Q_1 : Channel discharge (cfs)

Q_2 : Discharge intercepted (cfs)

$Q_3 = Q_1 - Q_2$: Carryover (cfs)

\forall : Volume of water intercepted (ft.³)

T: Time (sec.)

η : Efficiency ($Q_2/Q_1 \times 100\%$)

B: Top width of channel (ft.)*

D: Depth of channel (ft.)*

* Measurements taken at stations 1 ft., 2 ft. and 3 ft. upstream from the start of the inlet grating.

ΔH	Q_1	\forall	T	Q_2	Q_3	η	B (Swale)	B (Back)	D
13.78	1.55	68.1	60.6	1.12	0.43	72.5	3.17	0.0	0.182
							3.42		0.184
4.81	0.91	48.8	60.4	0.81	0.10	88.7	3.63	0.0	0.179
							2.25		0.154
							2.25		0.153
3.51	0.78	41.2	60.5	0.68	0.10	87.2	2.33	0.0	0.149
							2.25		0.154
							2.25		0.141
2.84	0.70	39.1	60.5	0.64	0.06	92.0	2.17	0.0	0.136
							2.17		0.142
							2.25		0.145
2.33	0.63	36.8	60.5	0.61	0.02	96.2	2.21	0.0	0.133
							2.13		0.136
							2.21		0.140
1.83	0.56	33.2	60.5	0.55	0.01	98.2	2.21	0.0	0.130
							2.00		0.124
							2.13		0.131
1.38	0.49	29.7	60.5	0.49	0.00	100.0	2.17	0.0	0.128
							1.96		0.117
							2.13		0.117
1.01	0.42			0.42	0.00	100.0	2.13	0.0	0.113
							1.79		0.111
							1.92		0.111
							2.08		0.108

Test No.: 41 Inlet: 6-Ft Special Date: Nov 10, 1971

Long. Slope: 4.0 % Swale Slope: 16:1 Back Slope: 1/8:1

Remarks: Depth taken at toe of curb. Spread onto back slope less than 0.05 ft.

SYMBOLS

- ΔH : Pressure-head drop across the orifice (ft. of water)
 Q_1 : Channel discharge (cfs)
 Q_2 : Discharge intercepted (cfs)
 $Q_3 = Q_1 - Q_2$: Carryover (cfs)
 Ψ : Volume of water intercepted (ft.³)
T: Time (sec.)
 η : Efficiency ($Q_2/Q_1 \times 100\%$)
B: Top width of channel (ft.)*
D: Depth of channel (ft.)*

* Measurements taken at stations 1 ft., 2 ft. and 3 ft. upstream from the start of the inlet grating.

ΔH	Q_1	Ψ	T	Q_2	Q_3	η	B (Swale)	B (Back)	D
13.50	1.53	80.2	62.8	1.28	0.25	83.6	2.96	0.0	0.193
							3.12		0.189
5.26	0.96	53.1	61.4	0.87	0.09	90.5	3.25	0.0	0.174
							2.38	0.0	0.157
							2.46		0.163
3.48	0.78	42.7	60.8	0.70	0.08	90.0	2.46	0.0	0.165
							2.25	0.0	0.138
							2.29		0.139
2.87	0.70	39.9	61.2	0.65	0.05	93.0	2.29	0.0	0.144
							2.17	0.0	0.132
							2.25		0.134
2.34	0.63	37.6	61.2	0.61	0.02	97.4	2.25	0.0	0.134
							2.13	0.0	0.117
							2.21		0.122
1.68	0.54	33.0	61.3	0.54	0.00	99.6	2.21	0.0	0.127
							2.04	0.0	0.120
							2.17		0.115
1.34	0.48			0.48	0.00	100.0	2.17	0.0	0.113
							1.92	0.0	0.118
							2.04		0.113
							2.13		0.110

Test No.: 42 Inlet: 4-Ft Special Date: Oct 12, 1971

Long. Slope: 4.0 % Swale Slope: 12:1 Back Slope: 1/8:1

Remarks: Depth taken at toe of curb. Spread onto back slope less than 0.05 ft.

SYMBOLS

ΔH : Pressure-head drop across the orifice (ft. of water)

Q_1 : Channel discharge (cfs)

Q_2 : Discharge intercepted (cfs)

$Q_3 = Q_1 - Q_2$: Carryover (cfs)

Ψ : Volume of water intercepted (ft.³)

T: Time (sec.)

η : Efficiency ($Q_2/Q_1 \times 100\%$)

B: Top width of channel (ft.)*

D: Depth of channel (ft.)*

* Measurements taken at stations 1 ft., 2 ft. and 3 ft. upstream from the start of the inlet grating.

ΔH	Q_1	Ψ	T	Q_2	Q_3	η	B (Swale)	B (Back)	D
14.20	1.57	69.6	60.5	1.15	0.42	73.2	2.54	0.0	0.201
							2.58		0.204
10.12	1.32	62.5	60.4	1.04	0.28	78.5	2.63	0.0	0.214
							2.46		0.187
							2.46		0.190
6.55	1.07	53.6	60.4	0.89	0.18	83.1	2.46	0.0	0.189
							2.33		0.176
							2.33		0.173
4.89	0.92	50.7	60.4	0.84	0.08	91.2	2.33	0.0	0.169
							2.17		0.163
							2.25		0.168
3.44	0.77	45.1	60.4	0.75	0.02	97.1	2.25	0.0	0.158
							2.04		0.155
							2.13		0.154
2.66	0.68	40.8	60.4	0.68	0.00	99.5	2.13	0.0	0.155
							1.88		0.149
							2.00		0.148
1.98	0.58			0.58	0.00	100.0	2.08	0.0	0.144
							1.62		0.141
							1.83		0.142
							1.96		0.138

Test No.: 43 Inlet: 6-Ft Special Date: Nov 11, 1971

Long. Slope: 4.0 % Swale Slope: 12:1 Back Slope: 1/8:1

Remarks: Depth taken at toe of curb. Spread onto back slope less than 0.05 ft.

SYMBOLS

ΔH : Pressure-head drop across the orifice (ft. of water)

Q_1 : Channel discharge (cfs)

Q_2 : Discharge intercepted (cfs)

$Q_3 = Q_1 - Q_2$: Carryover (cfs)

Ψ : Volume of water intercepted (ft.³)

T: Time (sec.)

η : Efficiency ($Q_2/Q_1 \times 100\%$)

B: Top width of channel (ft.)*

D: Depth of channel (ft.)*

* Measurements taken at stations 1 ft., 2 ft. and 3 ft. upstream from the start of the inlet grating.

ΔH	Q_1	Ψ	T	Q_2	Q_3	η	B (Swale)	B (Back)	D
13.60	1.53	80.3	60.6	1.32	0.21	86.6	2.50	0.0	0.198
							2.54		0.208
10.30	1.34	71.8	60.5	1.19	0.15	88.7	2.58	0.0	0.211
							2.41		0.193
5.16	0.95	53.5	60.6	0.88	0.07	92.8	2.46	0.0	0.190
							2.54		0.192
4.04	0.84	50.1	60.5	0.83	0.01	98.7	2.13	0.0	0.169
							2.25		0.167
3.47	0.78	46.8	60.5	0.78	0.00	99.4	2.25	0.0	0.160
							2.08		0.156
3.00	0.72			0.72	0.00	100.0	2.17	0.0	0.161
							2.21		0.158
							2.04	0.0	0.153
							2.13		0.153
							2.13		0.157
							1.92		0.152
							2.04	0.0	0.150
							2.17		0.150

Test No.: 46 Inlet: 4-Ft Special Date: Dec 17, 1971.

Long. Slope: 2 % Swale Slope: 48:1 Back Slope: 1/8:1

Remarks: Depth taken at toe of curb. Spread onto back slope less than 0.05 ft.

SYMBOLS

ΔH : Pressure-head drop across the orifice (ft. of water)

Q_1 : Channel discharge (cfs)

Q_2 : Discharge intercepted (cfs)

$Q_3 = Q_1 - Q_2$: Carryover (cfs)

Ψ : Volume of water intercepted (ft.³)

T: Time (sec.)

η : Efficiency ($Q_2/Q_1 \times 100\%$)

B: Top width of channel (ft.)*

D: Depth of channel (ft.)*

* Measurements taken at stations 1 ft., 2 ft. and 3 ft. upstream from the start of the inlet grating.

ΔH	Q_1	Ψ	T	Q_2	Q_3	η	B (Swale)	B (Back)	D
10.44	1.34	34.8	60.5	0.58	0.76	43.0	5.46	0.0	0.112
							5.50		0.118
3.83	0.82	29.0	60.6	0.48	0.34	58.3	5.50		0.115
							4.58	0.0	0.094
							4.58		0.100
1.87	0.56	24.1	60.4	0.40	0.16	71.3	4.70		0.098
							4.00	0.0	0.090
							4.00		0.094
1.04	0.42	19.6	60.7	0.32	0.10	76.8	4.00		0.087
							3.75	0.0	0.081
							3.75		0.085
0.44	0.27	14.0	60.1	0.23	0.04	86.1	3.70		0.080
							3.33	0.0	0.063
							3.42		0.066
0.16	0.16	9.3	60.1	0.15	0.01	96.8	3.42		0.067
							2.96	0.0	0.052
							3.08		0.054
0.067	0.11			0.11	0.00	100.0	3.08		0.050
							2.25	0.0	0.047
							2.46		0.049
							2.50		0.043

Test No.: 47 Inlet: 6-Ft Special Date: Dec 17, 1971.

Long. Slope: 2 % Swale Slope: 48:1 Back Slope: 1/8:1

Remarks: Depth taken at toe of curb. Spread onto back slope less than 0.05 ft.

SYMBOLS

ΔH : Pressure-head drop across the orifice (ft. of water)

Q_1 : Channel discharge (cfs)

Q_2 : Discharge intercepted (cfs)

$Q_3 = Q_1 - Q_2$: Carryover (cfs)

\forall : Volume of water intercepted (ft.³)

T: Time (sec.)

η : Efficiency ($Q_2/Q_1 \times 100\%$)

B: Top width of channel (ft.)*

D: Depth of channel (ft.)*

* Measurements taken at stations 1 ft., 2 ft. and 3 ft. upstream from the start of the inlet grating.

ΔH	Q_1	\forall	T	Q_2	Q_3	η	B (Swale)	B (Back)	D
1.93	0.58	26.7	66.6	0.40	0.18	69.1	4.08	0.0	0.090
							4.08		0.092
0.99	0.41	18.9	60.4	0.31	0.10	76.4	4.08	0.0	0.088
							3.71	0.0	0.080
							3.71		0.088
0.44	0.27	14.5	60.8	0.24	0.03	88.3	3.71	0.0	0.080
							3.42	0.0	0.063
							3.42		0.069
0.19	0.18	10.2	60.9	0.17	0.01	93.1	3.42	0.0	0.067
							2.92	0.0	0.053
							3.00		0.057
0.08	0.12			0.12	0.00	100.0	3.04	0.0	0.051
							2.46	0.0	0.050
							2.58		0.051
							2.71		0.043

Test No.: 48 Inlet: 4-Ft Special Date: Dec 16, 1971.

Long. Slope: 2% Swale Slope: 24:1 Back Slope: 1/8:1

Remarks: Depth taken at toe of curb. Spread onto back slope less than 0.05 ft.

SYMBOLS

ΔH : Pressure-head drop across the orifice (ft. of water)

Q_1 : Channel discharge (cfs)

Q_2 : Discharge intercepted (cfs)

$Q_3 = Q_1 - Q_2$: Carryover (cfs)

Ψ : Volume of water intercepted (ft.³)

T: Time (sec.)

η : Efficiency ($Q_2/Q_1 \times 100\%$)

B: Top width of channel (ft.)*

D: Depth of channel (ft.)*

* Measurements taken at stations 1 ft., 2 ft. and 3 ft. upstream from the start of the inlet grating.

ΔH	Q_1	Ψ	T	Q_2	Q_3	η	B (Swale)	B (Back)	D
10.45	1.34	54.8	62.9	0.87	0.47	65.0	4.00	0.0	0.169
							4.00		0.172
6.65	1.08	45.0	61.3	0.73	0.35	68.0	4.00	0.0	0.163
							3.71		0.146
3.52	0.78	35.7	61.0	0.59	0.19	75.1	3.75	0.0	0.162
							3.79		0.161
2.06	0.59	30.5	61.4	0.50	0.09	84.3	3.33	0.0	0.117
							3.42		0.130
1.32	0.48	27.0	60.8	0.44	0.04	92.5	3.42	0.0	0.134
							3.04		0.107
0.58	0.32			0.32	0.00	100.0	3.12	0.0	0.113
							3.16		0.107
							2.75	0.0	0.101
							2.88		0.110
							2.96	0.0	0.097
							2.12		0.096
							2.33	0.0	0.100
							2.50		0.095

Test No.: 49 Inlet: 6-Ft Special Date: Dec 16, 1971.

Long. Slope: 2 % Swale Slope: 24:1 Back Slope: 1/8:1

Remarks: Depth taken at toe of curb. Spread onto back slope less than 0.05 ft.

SYMBOLS

ΔH : Pressure-head drop across the orifice (ft. of water)

Q_1 : Channel discharge (cfs)

Q_2 : Discharge intercepted (cfs)

$Q_3 = Q_1 - Q_2$: Carryover (cfs)

Ψ : Volume of water intercepted (ft.³)

T: Time (sec.)

η : Efficiency ($Q_2/Q_1 \times 100\%$)

B: Top width of channel (ft.)*

D: Depth of channel (ft.)*

* Measurements taken at stations 1 ft., 2 ft. and 3 ft. upstream from the start of the inlet grating.

ΔH	Q_1	Ψ	T	Q_2	Q_3	η	B (Swale)	B (Back)	D
10.64	1.35	58.1	61.9	0.94	0.41	69.6	4.00	0.0	0.170
							4.00		0.175
							4.00		0.165
6.65	1.08	48.8	60.6	0.81	0.27	74.5	3.71	0.0	0.147
							3.71		0.164
							3.71		0.161
3.51	0.78	38.0	61.0	0.62	0.16	79.8	3.33	0.0	0.118
							3.37		0.130
							3.37		0.132
2.10	0.60	33.2	61.2	0.54	0.06	90.4	3.02	0.0	0.110
							3.12		0.113
							3.16		0.109
1.00	0.42	25.7	61.4	0.42	0.00	100.0	2.58	0.0	0.098
							2.75		0.109
							2.91		0.093

Test No.: 50 Inlet: 4-Ft Special Date: Dec 14, 1971.

Long. Slope: 2.0 % Swale Slope: 16:1 Back Slope: 1/8:1

Remarks: Depth taken at toe of curb. Spread onto back slope less than 0.05 ft.

SYMBOLS

- ΔH : Pressure-head drop across the orifice (ft. of water)
- Q_1 : Channel discharge (cfs)
- Q_2 : Discharge intercepted (cfs)
- $Q_3 = Q_1 - Q_2$: Carryover (cfs)
- \forall : Volume of water intercepted (ft.³)
- T: Time (sec.)
- η : Efficiency ($Q_2/Q_1 \times 100\%$)
- B: Top width of channel (ft.)*
- D: Depth of channel (ft.)*

* Measurements taken at stations 1 ft., 2 ft. and 3 ft. upstream from the start of the inlet grating.

ΔH	Q_1	\forall	T	Q_2	Q_3	η	B (Swale)	B (Back)	D
10.30	1.33	57.1	59.7	0.96	0.37	72.0	3.00	0.0	0.189
							3.00		0.197
6.70	1.08	47.4	59.1	0.80	0.28	74.0	3.00		0.211
							2.92	0.0	0.169
							2.92		0.174
3.38	0.76	40.8	61.2	0.67	0.09	87.7	2.92		0.177
							2.62	0.0	0.143
							2.71		0.154
2.36	0.64	36.2	61.8	0.59	0.05	91.5	2.75		0.149
							2.46	0.0	0.136
							2.58		0.144
1.66	0.53	31.5	59.9	0.53	0.00	99.2	2.67		0.141
							2.16	0.0	0.132
							2.33		0.140
0.79	0.37			0.37	0.00	100.0	2.46		0.132
							1.67	0.0	0.120
							1.71		0.122
							1.96		0.122

Test No.: 51 Inlet: 6-Ft Special Date: Dec 14, 1971.

Long. Slope: 2.0 % Swale Slope: 16:1 Back Slope: 1/8:1

Remarks: Depth taken at toe of curb. Spread onto back slope less than 0.05 ft.

SYMBOLS

- ΔH : Pressure-head drop across the orifice (ft. of water)
 Q_1 : Channel discharge (cfs)
 Q_2 : Discharge intercepted (cfs)
 $Q_3 = Q_1 - Q_2$: Carryover (cfs)
 \forall : Volume of water intercepted (ft.³)
T: Time (sec.)
 η : Efficiency ($Q_2/Q_1 \times 100\%$)
B: Top width of channel (ft.)*
D: Depth of channel (ft.)*

* Measurements taken at stations 1 ft., 2 ft. and 3 ft. upstream from the start of the inlet grating.

ΔH	Q_1	\forall	T	Q_2	Q_3	η	B (Swale)	B (Back)	D
10.09	1.31	64.0	60.8	1.05	0.26	80.3	2.96	0.0	0.184
							2.96		0.197
6.69	1.08	53.7	60.1	0.89	0.19	82.7	2.96		0.211
							2.87	0.0	0.168
							2.92		0.177
3.59	0.79	46.0	59.9	0.77	0.02	92.2	2.92		0.179
							2.66	0.0	0.144
							2.71		0.158
2.41	0.65	38.7	60.2	0.64	0.01	98.9	2.75		0.153
							2.42	0.0	0.136
							2.50		0.144
2.49	0.65			0.65	0.00	100.0	2.63		0.142
							2.42	0.0	0.137
							2.54		0.145
							2.63		0.142

Test No.: 52 Inlet: 4-Ft Special Date: Dec 14, 1971.

Long. Slope: 2.0 % Swale Slope: 12:1 Back Slope: 1/8:1

Remarks: Depth taken at toe of curb. Spread onto back slope less than 0.05 ft.

SYMBOLS

ΔH : Pressure-head drop across the orifice (ft. of water)

Q_1 : Channel discharge (cfs)

Q_2 : Discharge intercepted (cfs)

$Q_3 = Q_1 - Q_2$: Carryover (cfs)

Ψ : Volume of water intercepted (ft.³)

T: Time (sec.)

η : Efficiency ($Q_2/Q_1 \times 100\%$)

B: Top width of channel (ft.)*

D: Depth of channel (ft.)*

*Measurements taken at stations 1 ft., 2 ft. and 3 ft. upstream from the start of the inlet grating.

ΔH	Q_1	Ψ	T	Q_2	Q_3	η	B (Swale)	B (Back)	D
10.57	1.35	65.5	60.9	1.08	0.27	79.7	2.79	0.0	0.220
							2.83		0.225
6.87	1.10	58.2	60.5	0.96	0.14	87.2	2.92	0.0	0.222
							2.54		0.199
							2.62		0.199
3.51	0.78	43.8	60.6	0.72	0.06	92.5	2.71	0.0	0.203
							1.96		0.187
							2.16		0.183
2.68	0.68	40.1	60.7	0.66	0.02	97.3	2.33	0.0	0.180
							1.83		0.177
							2.00		0.178
1.44	0.49			0.49	0.00	100.0	2.21	0.0	0.177
							1.67		0.155
							1.67		0.163
							1.79		0.159

Test No.: 53 Inlet: 6-Ft Special Date: Dec 13, 1971.

Long. Slope: 2.0 % Swale Slope: 12:1 Back Slope: 1/8:1

Remarks: Depth taken at toe of curb. Spread onto back slope less than 0.05 ft.

SYMBOLS

- ΔH : Pressure-head drop across the orifice (ft. of water)
- Q_1 : Channel discharge (cfs)
- Q_2 : Discharge intercepted (cfs)
- $Q_3 = Q_1 - Q_2$: Carryover (cfs)
- \forall : Volume of water intercepted (ft.³)
- T: Time (sec.)
- η : Efficiency ($Q_2/Q_1 \times 100\%$)
- B: Top width of channel (ft.)*
- D: Depth of channel (ft.)*

* Measurements taken at stations 1 ft., 2 ft. and 3 ft. upstream from the start of the inlet grating.

ΔH	Q_1	\forall	T	Q_2	Q_3	η	B (Swale)	B (Back)	D
10.34	1.33	70.5	59.9	1.18	0.15	88.5	2.75	0.0	0.218
							2.79		0.228
6.55	1.07	60.0	60.3	1.00	0.07	93.0	2.79		0.218
							2.54	0.0	0.195
							2.67		0.199
5.25	0.96	55.2	60.2	0.92	0.04	95.5	2.71		0.201
							2.33	0.0	0.188
							2.50		0.195
4.63	0.90	53.2	59.6	0.89	0.01	99.0	2.54		0.192
							2.17	0.0	0.184
							2.42		0.192
4.24	0.86	50.8	60.0	0.85	0.01	98.2	2.50		0.185
							2.08	0.0	0.186
							2.29		0.190
2.89	0.71			0.71	0.00	100.0	2.42		0.183
							1.88	0.0	0.178
							2.00		0.178
							2.21		0.178

Test No.: 56 Inlet: 4-Ft Special Date: July 15, 1971.

Long. Slope: 1/2 % Swale Slope: 48:1 Back Slope: 1/8:1

Remarks: Depth taken at toe of curb. Spread onto back slope less than 0.05 ft.

SYMBOLS

ΔH : Pressure-head drop across the orifice (ft. of water)

Q_1 : Channel discharge (cfs)

Q_2 : Discharge intercepted (cfs)

$Q_3 = Q_1 - Q_2$: Carryover (cfs)

\forall : Volume of water intercepted (ft.³)

T: Time (sec.)

η : Efficiency ($Q_2/Q_1 \times 100\%$)

B: Top width of channel (ft.)*

D: Depth of channel (ft.)*

* Measurements taken at station 2 feet 9 inches upstream from the start of the inlet grating.

ΔH	Q_1	\forall	T	Q_2	Q_3	η	B (Swale)	B (Back)	D
6.88	1.10	20.4	40.4	0.51	0.59	45.9	6.00	0.0	0.152
5.03	0.94	19.1	41.3	0.46	0.48	49.1	5.71	0.0	0.152
3.30	0.76	16.6	41.6	0.40	0.36	52.4	5.33	0.0	0.150
2.63	0.67	14.2	40.6	0.35	0.32	52.3	5.16	0.0	0.158
2.00	0.59	12.7	40.5	0.31	0.28	53.7	5.00	0.0	0.149
1.32	0.48	11.2	40.9	0.27	0.21	57.0	4.79	0.0	0.136
0.32	0.23	6.7	40.3	0.17	0.06	72.3	4.00	0.0	0.110
0.004	0.03			0.03	0.00	100.0	1.17	0.0	0.038

Test No.: 57 Inlet: 6-Ft Special Date: July 15, 1971.

Long. Slope: 1/2 % Swale Slope: 48:1 Back Slope: 1/8:1

Remarks: Depth taken at toe of curb. Spread onto back slope less than 0.05 ft.

SYMBOLS

ΔH : Pressure-head drop across the orifice (ft. of water)

Q_1 : Channel discharge (cfs)

Q_2 : Discharge intercepted (cfs)

$Q_3 = Q_1 - Q_2$: Carryover (cfs)

V : Volume of water intercepted (ft.³)

T: Time (sec.)

η : Efficiency ($Q_2/Q_1 \times 100\%$)

B: Top width of channel (ft.)*

D: Depth of channel (ft.)*

* Measurements taken at station 2 feet 9 inches upstream from the start of the inlet grating.

ΔH	Q_1	V	T	Q_2	Q_3	η	B (Swale)	B (Back)	D
6.86	1.10	23.0	40.7	0.57	0.53	51.4	5.91	0.0	0.161
5.10	0.94	21.6	40.6	0.53	0.41	56.5	5.70	0.0	0.161
3.38	0.76	18.5	40.6	0.46	0.30	59.9	5.37	0.0	0.153
2.63	0.67	16.8	40.4	0.42	0.25	62.1	5.25	0.0	0.158
1.98	0.58	14.8	41.1	0.36	0.22	62.0	5.00	0.0	0.147
1.69	0.54	14.0	40.7	0.34	0.20	63.8	4.95	0.0	0.138
1.28	0.47	12.9	40.4	0.32	0.15	68.0	4.70	0.0	0.131
0.98	0.41	11.3	40.5	0.28	0.13	68.1	4.58	0.0	0.129
0.37	0.25	12.1	60.9	0.20	0.05	79.5	4.04	0.0	0.107
0.008	0.04			0.04	0.00	100.0	1.67	0.0	0.046

Test No.: 58 Inlet: 4-Ft Special Date: July 15, 1971

Long. Slope: 1/2 % Swale Slope: 24:1 Back Slope: 1/8:1

Remarks: Depth taken at toe of curb. Spread onto back slope less than 0.05 ft.

SYMBOLS

ΔH : Pressure-head drop across the orifice (ft. of water)

Q_1 : Channel discharge (cfs)

Q_2 : Discharge intercepted (cfs)

$Q_3 = Q_1 - Q_2$: Carryover (cfs)

V : Volume of water intercepted (ft.³)

T: Time (sec.)

η : Efficiency ($Q_2/Q_1 \times 100\%$)

B: Top width of channel (ft.)*

D: Depth of channel (ft.)*

* Measurements taken at station 2 feet 9 inches upstream from the start of the inlet grating.

ΔH	Q_1	V	T	Q_2	Q_3	η	B (Swale)	B (Back)	D
10.75	1.37	29.6	40.7	0.73	0.64	53.0	4.91	0.0	0.205
9.40	1.28	28.2	40.4	0.70	0.58	54.5	4.91	0.0	0.200
8.10	1.20	26.1	40.4	0.64	0.56	53.8	4.83	0.0	0.194
6.76	1.08	25.1	40.5	0.62	0.46	57.5	4.75	0.0	0.187
5.18	0.95	23.2	40.7	0.57	0.38	60.0	4.50	0.0	0.176
4.03	0.84	20.4	40.3	0.51	0.33	60.6	4.25	0.0	0.169
2.74	0.69	17.6	40.4	0.44	0.25	63.2	3.91	0.0	0.158
1.45	0.50	14.3	40.4	0.36	0.14	71.0	3.58	0.0	0.158
0.60	0.32	10.4	40.3	0.26	0.06	80.4	3.16	0.0	0.143
0.18	0.17	6.2	40.3	0.15	0.02	90.4	2.54	0.0	0.113
0.017	0.05			0.05	0.00	100.0	1.67	0.0	0.074

Test No.: 59 Inlet: 6-Ft Special Date: July 15, 1971
 Long. Slope: 1/2 % Swale Slope: 24:1 Back Slope: 1/8:1

Remarks: Depth taken at toe of curb. Spread onto back slope less than 0.05 ft.

SYMBOLS

- ΔH : Pressure-head drop across the orifice (ft. of water)
 Q_1 : Channel discharge (cfs)
 Q_2 : Discharge intercepted (cfs)
 $Q_3 = Q_1 - Q_2$: Carryover (cfs)
 Ψ : Volume of water intercepted (ft.³)
 T: Time (sec.)
 η : Efficiency ($Q_2/Q_1 \times 100\%$)
 B: Top width of channel (ft.)*
 D: Depth of channel (ft.)*

* Measurements taken at station 2 feet 9 inches upstream from the start of the inlet grating.

ΔH	Q_1	Ψ	T	Q_2	Q_3	η	B (Swale)	B (Back)	D
8.01	1.20	30.6	40.8	0.75	0.45	62.5	4.79	0.0	0.192
6.76	1.09	28.3	40.0	0.71	0.38	64.8	4.70	0.0	0.190
5.35	0.96	26.9	41.3	0.65	0.31	67.8	4.50	0.0	0.178
4.06	0.84	24.0	40.6	0.59	0.25	70.3	4.25	0.0	0.175
2.68	0.68	20.2	40.6	0.50	0.18	73.0	3.96	0.0	0.167
1.42	0.50	17.0	43.8	0.39	0.11	77.5	3.67	0.0	0.166
0.81	0.37	9.7	40.6	0.24	0.13	64.5	3.33	0.0	0.146
0.50	0.29	17.3	60.3	0.29	0.00	99.0	3.00	0.0	0.124
0.17	0.17			0.17	0.00	100.0	2.04	0.0	0.087

Test No.: 60 Inlet: 4-Ft Special Date: July 8, 1971.

Long. Slope: 1/2 % Swale Slope: 16:1 Back Slope: 1/8:1

Remarks: Depth taken at toe of curb. Spread onto back slope less than 0.05 ft.

SYMBOLS

ΔH : Pressure-head drop across the orifice (ft. of water)

Q_1 : Channel discharge (cfs)

Q_2 : Discharge intercepted (cfs)

$Q_3 = Q_1 - Q_2$: Carryover (cfs)

Ψ : Volume of water intercepted (ft.³)

T: Time (sec.)

η : Efficiency ($Q_2/Q_1 \times 100\%$)

B: Top width of channel (ft.)*

D: Depth of channel (ft.)*

* Measurements taken at station 2 feet 9 inches upstream from the start of the inlet grating.

ΔH	Q_1	Ψ	T	Q_2	Q_3	η	B (Swale)	B (Back)	D
14.58	1.60	44.8	40.8	1.10	0.50	68.6	3.87	0.0	0.258
13.32	1.52	42.8	40.9	1.05	0.47	69.0	3.83	0.0	0.256
12.04	1.46	41.4	41.3	1.00	0.46	68.6	3.75	0.0	0.250
10.57	1.36	38.0	40.6	0.94	0.42	69.0	3.71	0.0	0.241
9.30	1.28	36.8	41.1	0.90	0.38	70.0	3.63	0.0	0.233
7.96	1.19	35.7	41.2	0.87	0.32	72.7	3.54	0.0	0.224
6.68	1.08	33.8	40.9	0.83	0.25	76.5	3.42	0.0	0.213
5.25	0.96	30.0	40.6	0.74	0.22	76.9	3.25	0.0	0.209
4.01	0.84	27.0	41.5	0.65	0.19	77.3	3.08	0.0	0.205
2.65	0.67	22.9	40.8	0.56	0.11	83.7	2.87	0.0	0.196
1.40	0.49	17.8	40.7	0.44	0.05	89.1	2.54	0.0	0.178
0.41	0.26			0.26	0.00	100.0	2.12	0.0	0.150

Test No.: 61 Inlet: 6-Ft Special Date: July 8, 1971.

Long. Slope: 1/2 % Swale Slope: 16:1 Back Slope: 1/8:1

Remarks: Depth taken at toe of curb. Spread onto back slope less than 0.05 ft.

SYMBOLS

ΔH : Pressure-head drop across the orifice (ft. of water)

Q_1 : Channel discharge (cfs)

Q_2 : Discharge intercepted (cfs)

$Q_3 = Q_1 - Q_2$: Carryover (cfs)

Ψ : Volume of water intercepted (ft.³)

T: Time (sec.)

η : Efficiency ($Q_2/Q_1 \times 100\%$)

B: Top width of channel (ft.)*

D: Depth of channel (ft.)*

* Measurements taken at station 2 feet 9 inches upstream from the start of the inlet grating.

ΔH	Q_1	Ψ	T	Q_2	Q_3	η	B (Swale)	B (Back)	D
15.06	1.62	50.7	41.3	1.23	0.39	75.8	3.83	0.0	0.253
13.30	1.52	48.0	41.0	1.17	0.35	77.0	3.79	0.0	0.248
11.98	1.45	45.4	41.3	1.10	0.35	75.7	3.75	0.0	0.240
10.60	1.36	43.7	41.4	1.06	0.30	77.7	3.71	0.0	0.235
9.31	1.28	41.4	40.7	1.02	0.26	79.4	3.63	0.0	0.229
7.91	1.18	39.8	41.1	0.97	0.21	82.1	3.50	0.0	0.219
6.72	1.08	37.0	41.4	0.90	0.18	82.8	3.41	0.0	0.209
5.43	0.98	34.0	40.6	0.84	0.14	85.4	3.29	0.0	0.204
3.98	0.83	29.0	41.3	0.70	0.13	84.5	3.08	0.0	0.201
2.60	0.67	25.0	41.3	0.61	0.06	90.3	2.83	0.0	0.195
1.30	0.48	19.0	41.7	0.46	0.02	96.0	2.54	0.0	0.183
0.39	0.26			0.26	0.00	100.0	2.13	0.0	0.155

Test No.: 62 Inlet: 4-Ft Special Date: July 7, 1971.

Long. Slope: 1/2 % Swale Slope: 12:1 Back Slope: 1/8:1

Remarks: Depth taken at toe of curb. Spread onto back slope less than 0.05 ft.

SYMBOLS

- ΔH : Pressure-head drop across the orifice (ft. of water)
 Q_1 : Channel discharge (cfs)
 Q_2 : Discharge intercepted (cfs)
 $Q_3 = Q_1 - Q_2$: Carryover (cfs)
 \forall : Volume of water intercepted (ft.³)
T: Time (sec.)
 η : Efficiency ($Q_2/Q_1 \times 100\%$)
B: Top width of channel (ft.)*
D: Depth of channel (ft.)*

* Measurements taken at station 2 feet 9 inches upstream from the start of the inlet grating.

ΔH	Q_1	\forall	T	Q_2	Q_3	η	B (Swale)	B (Back)	D
14.67	1.60	49.5	41.8	1.18	0.42	74.0	3.37	0.0	0.276
13.34	1.54	46.8	40.9	1.14	0.40	74.3	3.29	0.0	0.270
11.98	1.45	44.4	41.5	1.07	0.38	73.6	3.21	0.0	0.264
10.75	1.37	43.5	41.3	1.05	0.32	76.9	3.12	0.0	0.252
9.31	1.28	41.4	41.3	1.00	0.28	78.3	3.04	0.0	0.242
8.01	1.19	38.8	41.3	0.94	0.25	78.8	2.96	0.0	0.242
6.65	1.08	35.7	41.4	0.86	0.22	79.8	2.83	0.0	0.239
5.25	0.95	31.7	41.1	0.77	0.18	81.1	2.67	0.0	0.229
3.95	0.83	28.6	40.9	0.70	0.13	84.2	2.58	0.0	0.228
2.70	0.68	25.4	41.3	0.62	0.06	90.5	2.46	0.0	0.214
1.32	0.48	18.9	41.5	0.46	0.02	95.1	2.16	0.0	0.193
0.36	0.25			0.25	0.00	100.0	1.75	0.0	0.166

Test No.: 63 Inlet: 6-Ft Special Date: July 7, 1971.

Long. Slope: 1/2 % Swale Slope: 12:1 Back Slope: 1/8:1

Remarks: Depth taken at toe of curb. Spread onto back slope less than 0.05 ft.

SYMBOLS

ΔH : Pressure-head drop across the orifice (ft. of water)

Q_1 : Channel discharge (cfs)

Q_2 : Discharge intercepted (cfs)

$Q_3 = Q_1 - Q_2$: Carryover (cfs)

\forall : Volume of water intercepted (ft.³)

T: Time (sec.)

η : Efficiency ($Q_2/Q_1 \times 100\%$)

B: Top width of channel (ft.)*

D: Depth of channel (ft.)*

* Measurements taken at station 2 feet 9 inches upstream from the start of the inlet grating.

ΔH	Q_1	\forall	T	Q_2	Q_3	η	B (Swale)	B (Back)	D
14.63	1.60	53.5	40.7	1.32	0.28	82.1	3.42	0.0	0.275
13.44	1.55	51.8	40.6	1.27	0.28	82.2	3.33	0.0	0.266
12.00	1.45	48.8	40.8	1.20	0.25	82.4	3.25	0.0	0.260
10.70	1.36	47.2	41.2	1.15	0.21	84.3	3.13	0.0	0.248
9.55	1.30	45.9	41.0	1.12	0.18	86.1	3.04	0.0	0.242
8.00	1.19	43.1	41.5	1.04	0.15	87.6	2.96	0.0	0.242
6.81	1.10	40.0	41.5	0.96	0.14	87.5	2.87	0.0	0.240
5.40	0.97	36.7	41.4	0.89	0.08	91.4	2.71	0.0	0.235
3.94	0.83	31.2	41.6	0.75	0.08	90.2	2.58	0.0	0.228
2.92	0.71	27.9	41.6	0.67	0.04	94.2	2.50	0.0	0.217
1.28	0.47			0.47	0.00	100.0	2.21	0.0	0.194

8. VITA

The author was born in China, in the Province of Canton, on November 9, 1944. He is the son of Mr. and Mrs. Robert Yee of Regina, Saskatchewan, Canada. He received his primary education in Hông Kong and his secondary education in Hong Kong and Canada.

Upon graduation from high school the author studied Civil Engineering at Saskatoon Campus, University of Saskatchewan. He received his Bachelor of Science in Civil Engineering Degree in 1970.

He was awarded a Research Assistantship to Lehigh University in August 1970, from which he was graduated in January 1972, receiving the degree of Master of Science in Civil Engineering.