

8-1-1993

Identification and Preliminary Assessment of Existing Precast Concrete Floor Framing Systems

Richard C. Prior

Stephen Pessiki

Richard Sause

Sarah Slaughter

Follow this and additional works at: <http://preserve.lehigh.edu/engr-civil-environmental-atlss-reports>

Recommended Citation

Prior, Richard C.; Pessiki, Stephen; Sause, Richard; and Slaughter, Sarah, "Identification and Preliminary Assessment of Existing Precast Concrete Floor Framing Systems" (1993). ATLSS Reports. ATLSS report number 93-07.: <http://preserve.lehigh.edu/engr-civil-environmental-atlss-reports/187>

This Technical Report is brought to you for free and open access by the Civil and Environmental Engineering at Lehigh Preserve. It has been accepted for inclusion in ATLSS Reports by an authorized administrator of Lehigh Preserve. For more information, please contact preserve@lehigh.edu.

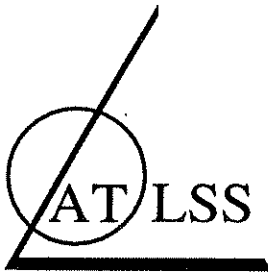

**ADVANCED TECHNOLOGY FOR
LARGE
STRUCTURAL SYSTEMS**

Lehigh University

**Identification and Preliminary Assessment of Existing
Precast Concrete Floor Framing Systems**

by

Richard C. Prior

Department of Civil Engineering

Stephen Pessiki

Assistant Professor of Civil Engineering

Richard Sause

Assistant Professor of Civil Engineering

Sarah Slaughter

Assistant Professor of Civil Engineering

Willem J. van Zyverden

Department of Civil Engineering

ATLSS Report No. 93 -07

August 1993

ATLSS Engineering Research Center

Lehigh University

117 ATLSS Dr., Imbt Laboratories

Bethlehem, PA 18015-4729

(215) 758-3525

An NSF Sponsored Engineering Research Center



Acknowledgements

This research was conducted with the support of the Center for Advanced Technology for Large Structural Systems (ATLSS). The work in this report was performed as part of ATLSS project ADC-10, *Development of New Floor Framing Systems for Gravity Loads*.

The authors gratefully acknowledge the assistance provided by several individuals in the conduct of this research:

Kenneth Baur, High Concrete Structures, Inc.
Mario Bertolini, Blakeslee Prestress, Inc.
Gary Cohen, Ballinger Company.
Leo Coldanapo, The Kling-Lindquist Partnership, Inc.
Michael Dravuschak, H.T. Lyons, Inc.
Paul Johal, Prestressed/Precast Concrete Institute.
Douglas Lorah, High Concrete Structures, Inc.
Martin Wasser, Ewing Cole Cherry Parsky.
Helmuth Wilden, H. Wilden & Associates, Inc.

Any opinions, findings, and conclusions expressed in this report are those of the authors and do not necessarily reflect the views of ATLSS or of the individuals acknowledged above.

Table of Contents

| | |
|--|------|
| ABSTRACT | ix |
| 1. INTRODUCTION | |
| 1.1 INTRODUCTION | 1-1 |
| 1.2 RESEARCH OBJECTIVES | 1-1 |
| 1.3 RESEARCH SIGNIFICANCE | 1-2 |
| 1.4 SUMMARY OF APPROACH | 1-2 |
| 1.5 SCOPE OF REPORT | 1-3 |
| 2. METHODOLOGY | |
| 2.1 INTRODUCTION | 2-1 |
| 2.2 SURVEY OF SYSTEMS | 2-1 |
| 2.3 DEVELOPMENT OF CRITERIA | 2-2 |
| 2.4 TERMINOLOGY | 2-3 |
| 3. SURVEY OF EXISTING PRECAST SYSTEMS | |
| 3.1 INTRODUCTION | 3-1 |
| 3.2 CURRENT SYSTEMS | 3-2 |
| 3.2.1 U.S. Conventional System | 3-2 |
| 3.2.2 Duotek System | 3-7 |
| 3.2.3 Dycore System | 3-10 |
| 3.2.4 Dyna-frame System | 3-13 |
| 3.2.5 Filigree Method of Construction | 3-18 |
| 3.2.5.1 Filigree Wideslab System | 3-19 |
| 3.2.5.2 PG Connection System | 3-21 |
| 3.2.5.3 RC Layered Construction System | 3-22 |
| 3.2.5.4 RPC-K System | 3-23 |
| 3.2.6 IMS System | 3-24 |
| 3.2.7 PD2 Frame System | 3-28 |
| 3.2.8 Prestressed Joist System | 3-32 |
| 3.2.9 Quickfloor System | 3-35 |
| 3.2.10 Structurapid System | 3-38 |
| 3.2.11 Swedish System | 3-41 |
| 3.2.12 Thomas System | 3-43 |
| 3.2.13 Trilposite System | 3-46 |
| 3.3 EMERGING SYSTEMS | 3-50 |
| 3.3.1 Contiframe System | 3-50 |
| 3.3.2 Spanlight System | 3-54 |
| 3.3.3 University of Nebraska System | 3-57 |
| 3.4 PRIMARY COMPONENTS OF ADDITIONAL SYSTEMS | 3-63 |
| 3.4.1 Cruciform Elements | 3-63 |
| 3.4.2 OHS Beam-to-Column Connection | 3-65 |
| 3.4.3 Trent T6 Connector | 3-67 |

| | |
|--|------|
| 4. CRITERIA | |
| 4.1 INTRODUCTION | 4-1 |
| 4.2 PRELIMINARY CRITERIA | 4-1 |
| 4.2.1 Structural | 4-2 |
| 4.2.1.1 Efficiency | 4-2 |
| 4.2.1.2 Performance | 4-7 |
| 4.2.2 Service | 4-7 |
| 4.2.2.1 Efficiency | 4-8 |
| 4.2.2.2 Performance | 4-10 |
| 4.2.3 Architectural | 4-11 |
| 4.2.3.1 Efficiency | 4-11 |
| 4.2.3.2 Performance | 4-12 |
| 4.3 CRITERIA FOR ASSESSMENT | 4-14 |
| | |
| 5. PRELIMINARY ASSESSMENT OF EXISTING PRECAST SYSTEMS | |
| 5.1 INTRODUCTION | 5-1 |
| 5.2 EXAMPLE BUILDINGS | 5-1 |
| 5.2.1 Structural Layout | 5-1 |
| 5.2.2 Selection and Layout of HVAC System | 5-2 |
| 5.2.2.1 Selection of HVAC System | 5-2 |
| 5.2.2.2 Layout of HVAC System | 5-2 |
| 5.3 APPLICATION OF ASSESSMENT CRITERIA | 5-3 |
| 5.3.1 Structural Criteria | 5-3 |
| 5.3.1.1 Fabrication Operations | 5-3 |
| 5.3.1.2 Truck Requirements | 5-4 |
| 5.3.1.3 Erection Operations | 5-5 |
| 5.3.2 Service Criteria | 5-6 |
| 5.3.2.1 Method of Service Installation | 5-6 |
| 5.3.2.2 Coordination Between Structural and Service Trades | 5-7 |
| 5.3.2.3 Service Maintenance | 5-7 |
| 5.3.2.4 Service Capacity | 5-8 |
| 5.3.3 Architectural Criteria | 5-9 |
| 5.3.3.1 Architectural Modification | 5-9 |
| 5.3.3.2 Spatial and Functional Versatility | 5-9 |
| 5.3.3.3 Building Height Versatility | 5-10 |
| 5.4 ASSESSMENT OF SYSTEMS | 5-10 |
| 5.4.1 U.S. Conventional System | 5-11 |
| 5.4.2 Duotek System | 5-12 |
| 5.4.3 Dycore System | 5-13 |
| 5.4.4 Dyna-frame System | 5-14 |
| 5.4.5 Filigree Wideslab System | 5-15 |
| 5.4.6 IMS System | 5-15 |
| 5.4.7 PD2 Frame System | 5-16 |
| 5.4.8 Prestressed Joist System | 5-17 |
| 5.4.9 Quickfloor System | 5-18 |
| 5.4.10 Structurapid System | 5-18 |
| 5.4.11 Swedish System | 5-19 |

| | |
|--|------|
| 5.4.12 Thomas System | 5-19 |
| 5.4.13 Trilposite System | 5-20 |
| 5.4.14 Contiframe System | 5-21 |
| 5.4.15 Spanlight System | 5-21 |
| 5.4.16 University of Nebraska System | 5-22 |
| 5.5 SUMMARY | 5-23 |
| 6. OPPORTUNITIES FOR NEW PRECAST STRUCTURAL SYSTEMS | |
| 6.1 INTRODUCTION | 6-1 |
| 6.2 STRUCTURAL EFFICIENCY AND PERFORMANCE | 6-1 |
| 6.3 SERVICE EFFICIENCY AND PERFORMANCE | 6-2 |
| 6.4 ARCHITECTURAL EFFICIENCY AND PERFORMANCE | 6-2 |
| 6.5 SUMMARY | 6-3 |
| 7. CONCLUSIONS, AND FUTURE WORK | |
| 7.1 INTRODUCTION | 7-1 |
| 7.2 CONCLUSIONS | 7-2 |
| 7.3 FUTURE WORK | 7-4 |
| REFERENCES | R-1 |

1
2
3
4
5
6
7
8
9
10
11
12
13
14
15
16
17
18
19
20
21
22
23
24
25
26
27
28
29
30
31
32
33
34
35
36
37
38
39
40
41
42
43
44
45
46
47
48
49
50
51
52
53
54
55
56
57
58
59
60
61
62
63
64
65
66
67
68
69
70
71
72
73
74
75
76
77
78
79
80
81
82
83
84
85
86
87
88
89
90
91
92
93
94
95
96
97
98
99
100

List of Tables

| | | |
|-------------|--|------|
| Table 2.1: | Companies and organizations that supplied system information. | 2-4 |
| Table 5.1: | Summary of building parameters for example buildings 1, 2, and 3. | 5-25 |
| Table 5.2: | Required duct sizes for selected sections of horizontal supply network shown in Figure 5.5. | 5-25 |
| Table 5.3: | Summary of fabrication requirements. | 5-26 |
| Table 5.4: | Truck requirements. | 5-26 |
| Table 5.5: | Summary of required field operations. | 5-27 |
| Table 5.6: | Field effort required. | 5-28 |
| Table 5.7: | Crane picks required: a) Example building 1; b) Comparison between example buildings 1, 2, and 3. | 5-29 |
| Table 5.8: | Evaluation of service efficiency and performance. | 5-30 |
| Table 5.9: | Spatial versatility. | 5-31 |
| Table 5.10: | Building height versatility. | 5-32 |
| Table 6.1: | Approach to improve structural efficiency and performance. | 6-5 |
| Table 6.2: | Approach to improve service efficiency and performance. | 6-5 |
| Table 6.3: | Approach to improve architectural efficiency and performance. | 6-6 |

List of Figures

| | | |
|--------------|--|------|
| Figure 3.1: | U.S. Conventional system. Typical beam-to-column connection. | 3-4 |
| Figure 3.2: | U.S. Conventional system. Floor unit-to-beam connection: a) Hollow-core plank bears on flange of inverted tee beam; b) Double tee is welded to the top of the inverted tee beam. | 3-5 |
| Figure 3.3: | U.S. Conventional system. Column-to-column connection. | 3-6 |
| Figure 3.4: | U.S. Conventional system. Column-to-footing connection. | 3-6 |
| Figure 3.5: | Duotek system. Precast double tees with stem openings. | 3-8 |
| Figure 3.6: | Duotek system. Precast primary beams with web openings: a) Inverted tee beam with openings on a 1.52 m (5 ft) module; b) Partial inverted tee beams with openings on a 1.52 m (5 ft) module. | 3-9 |
| Figure 3.7: | Dycore system. Composite Dycore structural system. | 3-12 |
| Figure 3.8: | Dyna-frame system. Dyna-frame structural components. | 3-15 |
| Figure 3.9: | Dyna-frame system. Detail showing column-to-beam connection. | 3-16 |
| Figure 3.10: | Dyna-frame system. Detail showing column footing. | 3-16 |
| Figure 3.11: | Dyna-frame system. Accommodation of services by using cantilevered beams. | 3-17 |
| Figure 3.12: | Filigree Method of Construction. Precast slab with light steel truss. | 3-18 |
| Figure 3.13: | PG Connection System. Cross-shaped beam-to-column component. | 3-21 |
| Figure 3.14: | RPC-K System. U shaped precast shell beam. | 3-23 |
| Figure 3.15: | IMS system. Modular composition possibilities for the IMS system: a) Single-unit systems; b) Two-unit systems; c) Four-unit systems. | 3-26 |
| Figure 3.16: | IMS system. Joint between floor units and column during construction. | 3-27 |
| Figure 3.17: | PD2 Frame system. Column-to-edge beam connection detail. | 3-30 |
| Figure 3.18: | PD2 Frame system. Accommodation of services. | 3-31 |
| Figure 3.19: | Prestressed Joist System. Soffit beam assembly for deep beams. | 3-34 |
| Figure 3.20: | Prestressed Joist System. Section of precast Keystone joist during erection. | 3-34 |
| Figure 3.21: | Quickfloor system. Typical beam cross-sections: a) Precast flat slab; b) Post-tensioned beam section for medium to long spans. | 3-37 |
| Figure 3.22: | Structurapid system. Footing-to-column and beam-to-column connection. | 3-40 |
| Figure 3.23: | Thomas system. U shaped shell beam. | 3-45 |
| Figure 3.24: | Trilposite system. Section through Trilposite floor system. | 3-48 |
| Figure 3.25: | Trilposite system. Incorporation of services. | 3-49 |
| Figure 3.26: | Contiframe system. Precast structural components. | 3-52 |
| Figure 3.27: | Contiframe system. Beam-to-column connection and bolted beam-to-beam mechanical connection. | 3-53 |
| Figure 3.28: | Spanlight system. Precast structural components. | 3-56 |
| Figure 3.29: | Spanlight system. Typical spine beam section. | 3-56 |
| Figure 3.30: | University of Nebraska system. Proposed structural system: a) Overview of system; b) Beam-to-column detail. | 3-59 |
| Figure 3.31: | University of Nebraska system. VII stage construction sequence. | 3-60 |
| Figure 3.32: | University of Nebraska system. Voids in proposed beam can house electrical and HVAC services. | 3-61 |
| Figure 3.33: | University of Nebraska system. Modification to system: a) Overview of system; b) Beam-to-beam detail. | 3-62 |

| | |
|--|------|
| Figure 3.34: Cruciform Elements: a) Two dimensional element; b) Three dimensional element. | 3-64 |
| Figure 3.35: Cruciform Elements. Beam-to-beam mechanical splice connection. | 3-64 |
| Figure 3.36: OHS Beam-to-Column Connection. The BSF prefabricated beam-to-column shear connection. | 3-66 |
| Figure 3.37: Trent T6 Connector. Bolted beam-to-column connector. | 3-68 |
| Figure 4.1: Structural, Service, and Architectural criteria. | 4-16 |
| Figure 4.2: Assessment criteria. | 4-17 |
| Figure 5.1: Example building 1. Structural layout. | 5-33 |
| Figure 5.2: Example building 2. Structural layout. | 5-34 |
| Figure 5.3: Example building 3. Structural layout. | 5-35 |
| Figure 5.4: Schematic of typical HVAC system used for example building 1. | 5-36 |
| Figure 5.5: HVAC layout, example building 1. | 5-36 |

Abstract

This report presents research progress on ATLSS project ADC-10, *Development of New Floor Framing Systems for Gravity Loads*. This project has two broad objectives: (1) to explore the development of new structural systems for gravity loads; and (2) to develop a methodology for the systematic comparison and evaluation of different structural systems. The present work focuses on the development of new concepts for precast concrete structural floor systems for occupied office buildings with regular spacing of columns or bearing walls.

A survey of existing precast structural systems is given. A total of 19 existing precast structural systems developed in the U.S., Europe, and Japan are included in this survey. Information provided for each system includes a description of the structural system, the construction procedure, and the incorporation of HVAC, plumbing, and electrical systems.

Assessment criteria that provide a consistent basis for evaluating precast structural systems have been developed. The assessment criteria are grouped into three categories: (1) Structural; (2) Service; and, (3) Architectural.

The assessment criteria are applied to the systems in the survey to provide a preliminary assessment of these existing systems. Based on this assessment, opportunities for the development of new precast structural systems are identified. The identified opportunities are presented in terms of the desired physical attributes of precast structural systems which will improve either structural, service, or architectural efficiency and performance.

1
2
3
4
5
6
7
8
9
10
11
12
13
14
15
16
17
18
19
20
21
22
23
24
25
26
27
28
29
30
31
32
33
34
35
36
37
38
39
40
41
42
43
44
45
46
47
48
49
50
51
52
53
54
55
56
57
58
59
60
61
62
63
64
65
66
67
68
69
70
71
72
73
74
75
76
77
78
79
80
81
82
83
84
85
86
87
88
89
90
91
92
93
94
95
96
97
98
99
100

Chapter 1

Introduction

1.1 INTRODUCTION

Structural floor systems comprise a major portion of both the cost and weight of precast concrete buildings. Structural floor systems in multi-story buildings also have a significant impact on the overall building height and on the design and installation of service systems, including plumbing (i.e., supply, drain-waste-vent, and fire protection), HVAC (i.e., heating, ventilation, and air conditioning), and electrical (i.e., power, security, and communication) systems. Therefore, it appears that significant improvements in overall building system efficiency can be gained by improving precast structural floor systems to reduce weight, depth, and cost, and to better accommodate service systems.

Traditional approaches to improving floor system efficiency have sought to minimize the weight, depth, and cost of structural floor systems through the use of new or higher strength materials and improved construction techniques. Automated fabrication and erection technologies offer additional potential for reduced fabrication and erection cost and time. In addition, a third opportunity exists in the better accommodation of service systems. The costs associated with the structural system are a dwindling proportion of the total construction costs of a typical building. On average, the cost of the structural system is currently 17% of the construction costs of a building, while the cost of the service systems is currently 38% [Means 1992]. Thus, the overall efficiency of the building system can be improved by developing new floor systems that are efficient in terms of weight, depth, cost, and the accommodation of service systems.

In order to address these opportunities, new and innovative concepts for precast concrete floor systems are needed. The main objective of the research described in this report is to develop new precast concrete floor systems for gravity loads for application in occupied office buildings with a regular spacing of columns or bearing walls.

1.2 RESEARCH OBJECTIVES

The research presented in this report is part of a project titled *Development of New Floor Framing Systems for Gravity Loads*. This project has two broad objectives:

1. To explore the development of new structural systems for gravity loads; and,
2. To develop a methodology for the systematic comparison and evaluation of different structural systems.

The present work, part of which is presented in this report, focuses on the development of new concepts for *precast concrete floor systems*. These floor systems are developed to carry gravity loads in occupied office buildings with a regular spacing of columns or bearing walls.

The project has evolved from a Precast/Prestressed Concrete Institute (PCI) research project statement entitled "Economical Framing Systems for Floors and Roofs," to include some of the broader research interests of the authors, and to consider the broader strategic objectives of the ATLSS Center.

1.3 RESEARCH SIGNIFICANCE

The research addresses the need for innovation in the construction of precast concrete buildings. Structural floor systems are a major portion of both the cost and weight of precast concrete buildings. Structural floor systems also have a significant impact on the overall height of multi-story buildings, and on the design and installation of service systems. The new precast concrete structural systems sought by this research offer the potential for significant improvements in overall building efficiency. The research will also develop criteria for assessing structural systems in order to measure these improvements.

1.4 SUMMARY OF APPROACH

The research has been separated into three tasks as follows:

Task 1: Assess current and emerging precast concrete structural floor systems

- Task 1.1 - survey of current and emerging precast structural systems;
- Task 1.2 - develop assessment criteria to evaluate precast structural systems;
- Task 1.3 - apply assessment criteria to precast structural systems in the survey.

Task 2: Develop new concepts for precast structural floor systems

- Task 2.1 - identify opportunities for new precast structural systems;
- Task 2.2 - propose new precast structural systems; and
- Task 2.3 - apply assessment criteria to new precast structural systems.

Task 3: Detailed development of most promising new concepts from Task 2

This progress report describes the results of work performed up to and including Task 2.1 - identification of opportunities for new precast structural systems.

Task 1 involves the assessment of current and emerging precast concrete structural floor systems. The survey of systems (Task 1.1) includes 19 precast concrete structural systems developed in the last 30 years in the United States and abroad. Assessment criteria are established (Task 1.2) to provide a consistent method for evaluating the effectiveness of the different systems. The assessment criteria are also used to guide the development of new systems (Task 2). These criteria are applied to the systems in the survey to provide an indication of the current state-of-the-art in precast concrete structural systems (Task 1.3).

Task 2 involves the development of new precast structural systems. The opportunities identified in the assessment in Task 1, as well as the criteria used to evaluate these systems, serve as the basis for the development of new systems.

It is expected that the completion of Task 2 will lead to concepts for several new precast structural systems, or improvements to existing precast structural systems. Task 3 involves the detailed development of the most promising new concepts. This will include the development of design examples and details.

1.5 SCOPE OF REPORT

As noted previously, this progress report describes the results of work performed up to and including Task 2.1 - identification of opportunities for new precast structural systems. A second report (van Zyverden et al. in preparation) describes the concepts that have been developed for new systems (Tasks 2.2 and 2.3).

The research involved extensive industry interaction for the survey of systems (Task 1.1) and the development of assessment criteria (Task 1.2). This industry interaction is described in Chapter 2.

The survey of existing precast systems (Task 1.1) is presented in Chapter 3. This includes a description of the structural system, construction procedure, and the method of incorporating HVAC, plumbing, and electrical systems.

Chapter 4 presents the development of the assessment criteria (Task 1.2).

Chapter 5 presents the preliminary assessment (Task 1.3) of the precast structural systems described in Chapter 3, using several of the criteria presented in Chapter 4.

Opportunities for new precast structural systems are identified in Chapter 6.

Chapter 7, provides a summary of the report and the conclusions. Also provided is a discussion of the proposed future work.

1
2
3
4
5
6
7
8
9
10
11
12
13
14
15
16
17
18
19
20
21
22
23
24
25
26
27
28
29
30
31
32
33
34
35
36
37
38
39
40
41
42
43
44
45
46
47
48
49
50
51
52
53
54
55
56
57
58
59
60
61
62
63
64
65
66
67
68
69
70
71
72
73
74
75
76
77
78
79
80
81
82
83
84
85
86
87
88
89
90
91
92
93
94
95
96
97
98
99
100

Chapter 2

Methodology

2.1 INTRODUCTION

This chapter describes the methodology followed to perform two key research tasks, the survey of existing precast systems (Task 1.1) and the development of assessment criteria (Task 1.2). Extensive industry interaction was involved in the completion of these tasks. Section 2.2 describes the approach taken to complete the survey of systems, and Section 2.3 describes the approach taken to develop the assessment criteria.

2.2 SURVEY OF SYSTEMS

Information on existing precast systems was collected primarily from two sources: concrete-related publications and precast manufacturers. Information was collected on precast structural systems suitable for all types of buildings (commercial, residential, industrial, etc.) even though the focus of this research is on the development of frame structural systems for office buildings. Information was not collected on load-bearing wall structures.

First a literature search was performed, treating information published from 1965 to the present. The following publications were included in this search:

| | |
|---|---|
| <i>ACI Structural Journal</i> | <i>Industrialization Forum</i> |
| <i>Betonwerk + Fertigteil - Technik</i> | <i>Journal of American Concrete Institute</i> |
| <i>Building Design & Construction</i> | <i>Journal of the Const. Div. of ASCE</i> |
| <i>Civil Engineering (London)</i> | <i>Magazine of Concrete Research</i> |
| <i>Civil Engineering (NY)</i> | <i>Modern Concrete</i> |
| <i>Concrete</i> | <i>New York Construction News</i> |
| <i>Concrete Construction</i> | <i>PCI Journal</i> |
| <i>Concrete International</i> | <i>Progressive Architecture</i> |
| <i>Construction Review</i> | <i>The Structural Engineer</i> |
| <i>Engineering News Record</i> | |
| <i>FIP Conference Proceedings</i> | |

This search revealed very few detailed descriptions of precast structural systems. Three useful references which review a number of precast structural systems are Building Design and Construction [1970], Industrialization Forum [1973-1978], and Low, Tadros, and Nijhawan [1991]. Additional information was collected from a number of books and reports: Deeson [1965], Diamant [1965], Fogarasi [1986], Yoshizaki et al. [1990].

The most detailed and most useful information was obtained from precast manufacturers and/or developers of particular precast structural systems. Table 2.1 lists companies and organizations that were contacted and responded to a request for information about precast structural systems. The following information was requested for each system: when the system

was first developed and used, intended building type, extent to which the system has been used, description of structural components, connection details, construction sequence, and manner in which service (i.e., HVAC, plumbing, and electrical) systems are incorporated into the building system.

2.3 DEVELOPMENT OF CRITERIA

Criteria are defined as characteristics of the structural system or of its interaction with other systems in the building which allows a judgement to be made about the effectiveness of the structural system. These criteria were developed with the input of industry professionals. Interviews were conducted with precast concrete designers, precast concrete fabricators, and mechanical (i.e. HVAC and plumbing) designer, and fabricators. The following individuals participated in the interviews used to develop the assessment criteria:

Kenneth C. Baur, Director of Engineering & Project Management, High Concrete Structures, Inc.
Mario Bertolini, President, Blakeslee Prestress, Inc.
Gary Cohen, Chief Mechanical Designer, Ballinger Company.
Leo Coldanapo, Mechanical Designer, The Kling-Lindquist Partnership, Inc.
Michael Dravuschak, H.T. Lyons, Inc. (mechanical system fabricator).
Douglas Lorah, Vice President, Production, High Concrete Structures, Inc.
Martin Wasser, Mechanical Designer, Ewing Cole Cherry Parsky.
Helmuth Wilden, H. Wilden & Associates, Inc. (precast design firm).

To facilitate the discussions in the interviews, the industry participants were sent a detailed description of seven precast structural systems identified in the survey of systems. The information sent to each individual included a description of the structural system, construction procedure, and the manner in which HVAC, plumbing, and electrical services are included in the system. The seven systems used for discussion purposes in the interviews are listed below. These systems were selected because they provided a good overview of all of the systems in the survey, and because they included some unique features of particular interest as described below:

1. *Conventional precast system for office structures in the United States* - This system was included because each precast professional was very familiar with the system and could provide insight into the advantages and limitations of the system.
2. *Dycore system* - This system was included because of the relatively shallow floor depth which can be obtained with the system, and also because it requires significantly more fieldwork than many precast structural systems. This system was also included to determine the feasibility of using the cellular raceways of hollow-core planks for electrical and plumbing services.
3. *Dyna-frame system* - This system was included to obtain feedback on the standardized column-to-column and beam-to-column connection used with the system. The system was also included because of its potential to accommodate service systems without increasing total floor depth.

4. *Filigree Wideslab system* - Filigree construction was included because of the large amount of fieldwork required with the system. Also of interest was the feasibility of using the cast-in-place portion of the floor slab for electrical and plumbing services.

5. *Tri/posite system* - The Tri/posite system was included because service systems are integrated with the structural floor system. Of particular interest was the practicality of incorporating services into the precast floor system. The system also appeared to have unique fabrication requirements.

6. *PD2 Frame system* - This system was included for two reasons. First, to determine the fabrication requirements associated with the complex end geometry of the floor planks. Second, to evaluate the advantages of using notched beams to accommodate electrical and plumbing services.

7. *Duotek system* - The Duotek system was included because of its modularity and because it contains holes in beams and floor units. The system was interesting from a fabrication standpoint and also in terms of how effectively service systems are accommodated.

A prefabricated connection, the OHS Beam-to-Column Connection, was also sent to the precast designers and fabricators for discussion. Potential problems with fabrication tolerances, and possible savings in erection costs were of particular interest.

2.4 TERMINOLOGY

The following terminology is used throughout this report:

Building System - The structural, service, and architectural systems of the building;

Structural System - All structural components of the building, including precast members, cast-in-place members, cast-in-place connections, welded connections, and bolted connections;

Service Systems - Electrical (i.e., power, security, and communication) system, plumbing (i.e., supply, drain-waste-vent, and fire protection) system, and HVAC equipment and ductwork;

Architectural System - Architectural elements including interior spaces, building function, materials, partitions, exterior enclosures, noise control, thermal storage, and safety system;

Floor System - The structural floor system and the space below the floor (and above the finished ceiling of the level below) that is required for service systems and architectural systems.

| Precast System | Company / Organization |
|------------------------|--|
| Contiframe | Contiframe Structures Ltd. |
| Duotek | Portland Cement Association |
| Dycore | Finfrook Industries, Inc. |
| Dyna-frame | Strescon Industries, Inc., Price Brothers Co., Flexicore Systems, Inc. |
| Filigree Wideslab | Mid-State Filigree Systems, Inc., Omnia Concrete Floors, Ltd. |
| OHS Connection | Østspenn Holding A/S, Østlandske Spennbetong A/S |
| PD2 Frame | Bison Concrete Ltd. |
| Prestressed Joist | Prestressed Systems Industries, Cast-Crete Tampa |
| Quickfloor | Quickfloor America, Inc. |
| Spanlight | Dow Mac Projects |
| Swedish | AB Strangbetong |
| Trent T6 Connector | Trent Concrete Structures Ltd. |
| Trilposite | Portland Cement Association |
| University of Nebraska | University of Nebraska - Lincoln |

Table 2.1. Companies and organizations that supplied system information.

Chapter 3

Survey of Existing Precast Systems

3.1 INTRODUCTION

Numerous proprietary and non-proprietary precast structural systems have been developed in the United States and abroad in the last thirty years. While many of these systems have been developed for residential structures, numerous others have been developed for multi-story commercial structures. This report identifies a total of 19 precast structural systems which are suitable for the construction of office buildings. For clarity, office buildings are defined as multi-story, occupied structures, requiring square or rectangular bay sizes of 7.5 m (25 ft) or greater. The systems identified have originated in the United States, Great Britain, Canada, Sweden, Hungary, Italy, Japan, and Australia.

A distinction is made between current systems (Section 3.2) and emerging systems (Section 3.3). Current systems are those precast systems which have been used in the construction industry. Almost all of these systems are currently used in multi-story office building construction. Emerging systems are those systems which are still under development, or awaiting patent approval. Each system in the survey is described using the same format. 1) Excluding conventional systems, a developer is indicated for each system. This is the company or organization which either originally developed the structural system, or is presently a major manufacturer of the precast structural components. 2) An overview is provided for each system. The overview provides information about the unique aspects of the structural system, indicating what precast components or techniques make the system competitive. Also included in this section is information on the type of buildings which have been constructed with the system, and the geographic region in which it is used. 3) A separate section is provided for a description of the system's precast structural components. A geometrical description and information about the materials required is included for each precast component. 4) The fourth section provides a structural description of the system. All structural components which make up the system are indicated, and a description is provided on how elements are joined. Typical span lengths, bay sizes, and loadings are also indicated. 5) A separate section provides information on the method of erection, and the sequence of construction. 6) An additional section is included which describes how HVAC, plumbing and electrical services are incorporated into the structural system. The primary components of three additional structural systems have also been included in this chapter (Section 3.4). These three components have been included because of their unique beam-to-beam and beam-to-column connections. An overview is provided for each component. A separate section provides a description of the precast connections associated with these components.

3.2 CURRENT SYSTEMS

3.2.1 U.S. Conventional System

Overview:

The conventional precast system for office structures in the United States consists of precast inverted tee beams, L shaped spandrel beams, multi-story columns, and hollow-core planks or double tees as floor members. The system uses cast-in-place concrete only for a floor topping. In general simple span members are employed, with connections resisting shear and not moment. For a 9.14 m (30 ft) span and typical office loading a beam depth of approximately 812 mm (32 in.) is required.

Precast components:

Columns Multi-story columns are cast up to six stories in height. Columns are cast with up to three corbels at each level. For interior columns where a corbel is required on each side of the column, the fourth corbel may be cast onto the column at a later time, or cast separately and attached to the column by welding steel angles to plates cast in the columns.

Beams Prestressed inverted tee beams span between columns and support the flooring units. Exterior spandrel beams are L shaped to support the flooring unit. As shown in Figure 3.1, beams are cast with an embedded steel plate to allow for a welded beam-to-column connection.

Floor units Floor units are either hollow-core planks or shallow double tees. The double tee floor members are typically used with a cast-in-place floor topping, while the hollow-core planks do not necessarily need a topping.

Structural description:

The conventional system can be characterized as a system comprised of simple span members, which employs very little cast-in-place concrete. Gravity loads are transferred from floor units to inverted tee beams, and then to column corbels. Horizontal loads are usually transmitted to shear walls through the roof and floors acting as horizontal diaphragms. In floors without composite topping, the shear transfer between deck members is usually accomplished by weld plates or grout keys. In floors with a composite topping, the topping itself can act as the diaphragm if it is adequately reinforced. The typical connections between components are described below:

Beam-to-Column - The beam rests on a chloroprene bearing pad which provides uniform bearing and permits small movements to accommodate the effect of shrinkage, creep, and temperature. The top connection transfers horizontal forces between the beam and column, provides erection stability, and braces the column, but does not provide rotational restraint. When a steel angle is used, only the toes are welded to the beam and the column to allow for rotation and to minimize negative moments at the beam ends (Figure 3.1).

Floor Unit-to-Beam - The type of connection employed is dependent on the magnitude of lateral forces in the diaphragm, and whether the member has composite topping to transfer forces. Precast hollow-core slabs typically bear on a narrow masonite or plastic strip, and double tees bear on a narrow chloroprene strip (Figure 3.2a). Double tees are typically joined to beams with two welded top connections as shown in Figure 3.2b. This is sufficient to provide erection stability, and transfer diaphragm forces.

Column-to-Column - The typical column to column connection is a grouted sleeve connection as shown in Figure 3.3. Sleeves are placed in either the upper or lower column in order to accept projecting reinforcement from the joining column. After alignment, the sleeves are grouted. The space between column sections is filled with non shrink grout. Temporary support and leveling must be provided until the grout in the sleeves is cured. A number of proprietary devices for splicing bars are available in the market.

Construction sequence:

- Column footings are cast with four anchor bolts projecting approximately 200 mm (8 in.) from the top of the footing as shown in Figure 3.4. A shim plate is centered on the footing.

- The column is guided over the anchor bolts. With the column bearing on the shim plate, leveling nuts can be used to align the column vertically.

- The column is braced. For precast columns up to two stories in height, steel pipe bracing can be used. Cable guys with turnbuckles are used for taller structures [PCI 1992].

- Column pockets and the gap created by the shim plate (Figure 3.4) are filled with non-shrink grout.

- Bearing pads typically 13 mm (1/2 in.) in thickness are placed on column corbels. Spandrel beams and inverted tee beams are positioned on the bearing pads.

- Once the beam is aligned, a steel clip angle typically 100 x 100 x 10 mm (4 x 4 x 3/8 in.) is welded to the beam and column. Weld locations are shown in Figure 3.1.

- A bearing strip is placed on the bearing surface of inverted tee beams and spandrel beams. Double tees are placed on the bearing strip. Double tees are joined to the inverted tee beam with two welded top connections, as shown in Figure 3.2b.

- Adjacent double tees are joined by weld bars, and hollow-core planks are joined with high strength grout which is placed in the groove (shear key) between flanges (Figure 3.2a).

- A concrete topping is placed. The minimum concrete topping is 50 mm (2 in.).

- Hardware to suspend HVAC, plumbing and electrical services is anchored to precast floor members and the service components are installed.

Incorporation of HVAC, plumbing and electrical services:

HVAC, plumbing, and electrical services are typically suspended beneath the structural floor system. The required ducts are suspended with standard manufactured hardware. When precast slabs are used, the inserts are installed in the joints between slabs, or anchors are drilled or shot into the slab at the site. When hollow-core planks are used, holes can be drilled for toggle or expansion type bolts or anchors. If double tees are chosen as the precast floor member, the duct system can run longitudinally between tee stems, without contributing to the total depth of the floor system. To run transversely, the ducts will pass under the tee stems and add to the total depth of the floor system. To better accommodate this, many systems have the ducts in the transverse direction at the exterior of the building, with a lower ceiling in this location only. Other designs use a deeper total floor depth in central corridors where a lower ceiling is possible. Another alternative is to design the HVAC duct system to pass under the primary beams in just one location. In this location, a utility closet can be placed to hide the duct system and to allow the total floor depth to remain shallow in the other areas of the structure.

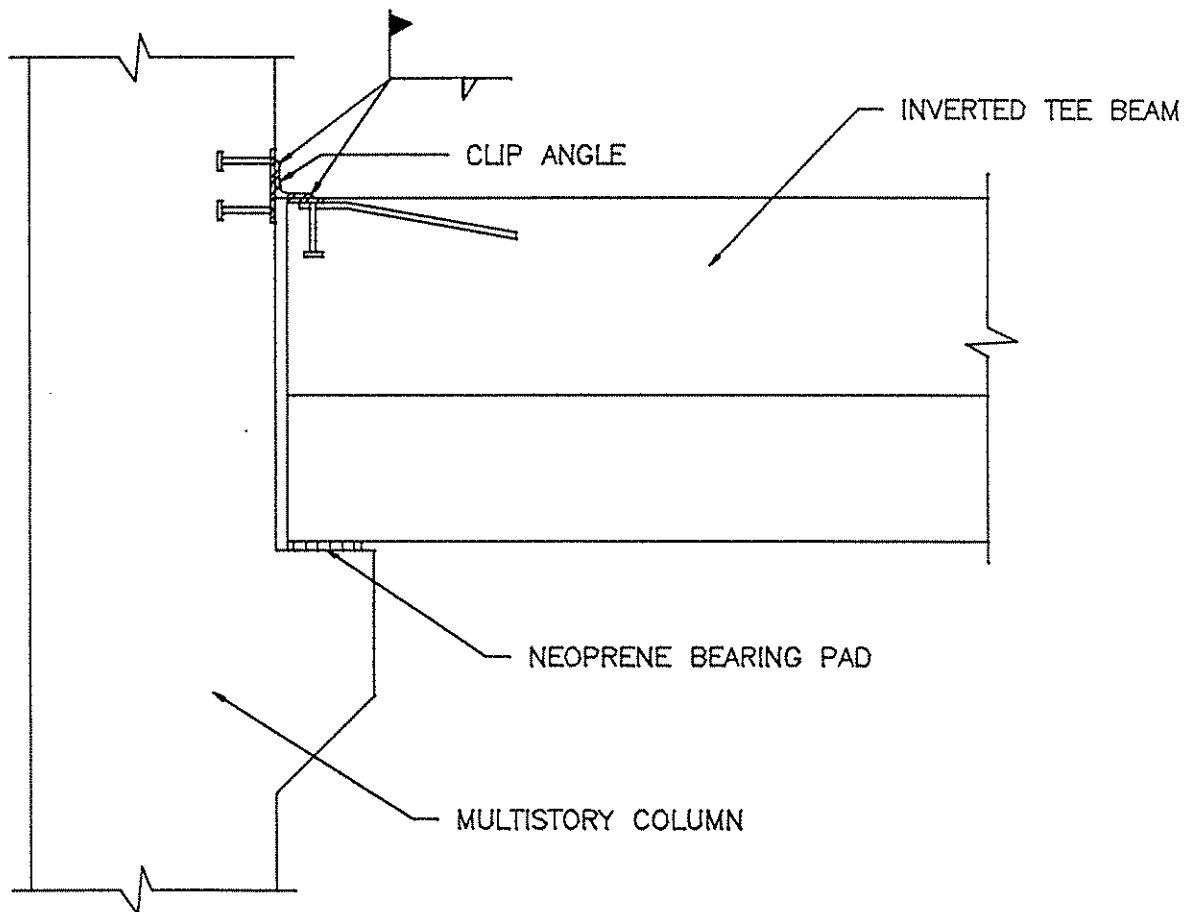
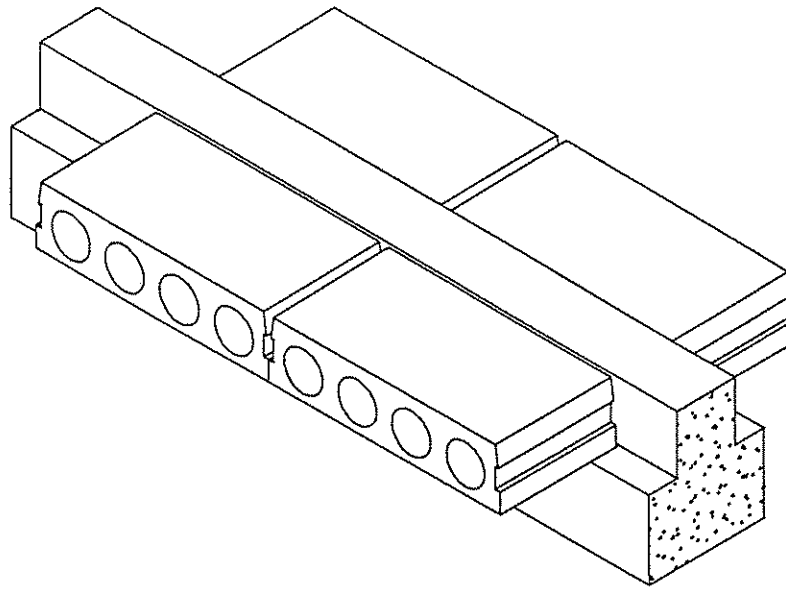
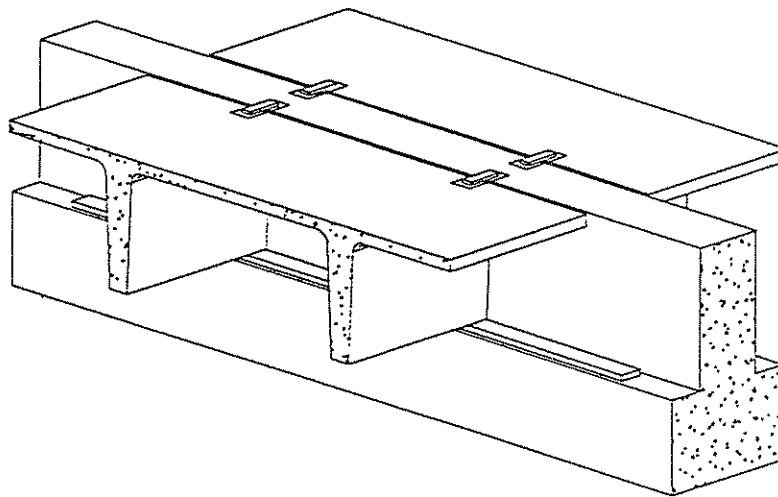

Figure 3.1. Typical beam-to-column connection. Steel plates are anchored with studs into the precast beam and column. A steel angle, welded at the toes, forms the simple connection.



(a)



(b)

Figure 3.2. Floor unit-to-beam connection: a) Hollow-core plank bears on flange of inverted tee beam; b) Double tee is welded to the top of the inverted tee beam.

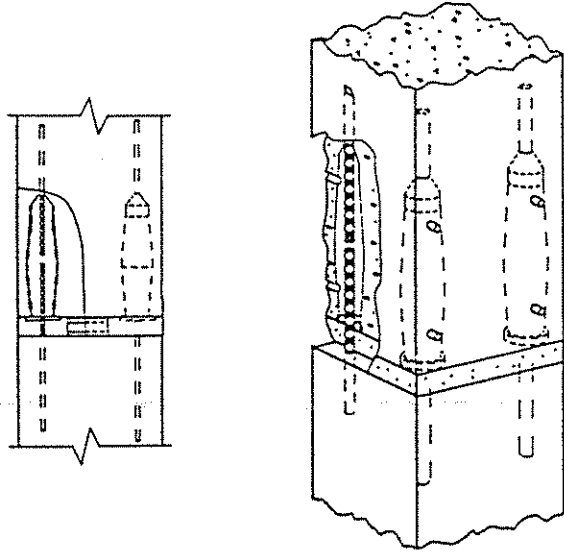

Figure 3.3. Column-to-column connection.

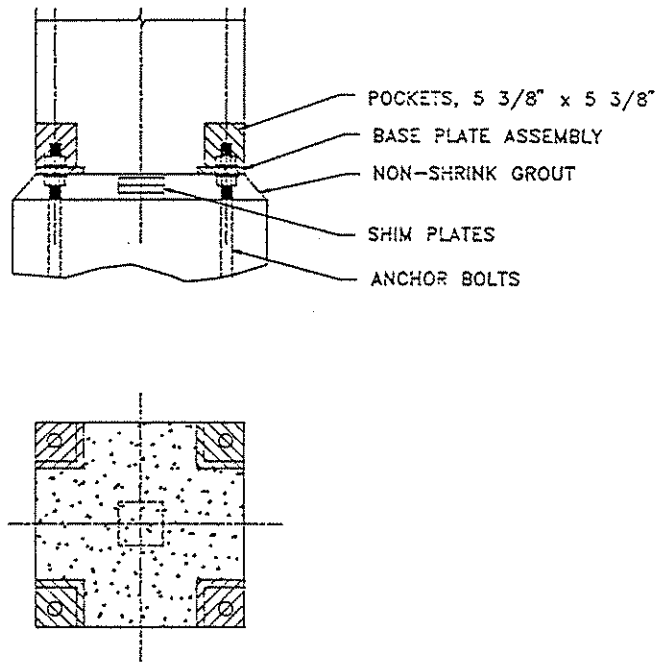

Figure 3.4. Column-to-footing connection.

3.2.2 Duotek System

Developer: Ontario Precast Concrete Manufacturers Association and
Portland Cement Association
5420 Old Orchard Road
Skokie, IL 60077-1083
United States

Overview:

The Duotek system is a modular structural system that provides for the accommodation of building services and components. The system consists of three precast concrete elements; columns, prestressed beams, and prestressed tee slabs, together with cast-in-place connections between primary beams and columns. Beams and tee slabs are a constant depth, and the floor system occupies a constant 1.22 m (4 ft) total floor depth from underside of ceiling to top of floor finish. Openings through primary beams and tee stems are provided at 1.52 m (5 ft.) modular centers to accommodate the HVAC, plumbing, and electrical services.

Duotek was developed in the late 1960's by the Ontario Precast Concrete Manufacturers Association and the Ontario Division of the Portland Cement Association [Ontario Precast Concrete Manufacturers Association and PCA]. The system was designed specifically for office or institutional structures. It is reported that greatest economy can be achieved in buildings which have large bay sizes. It is not clear to what extent the system has been used in the precast construction industry.

Precast components:

Columns Columns are manufactured in two sets of sizes dependent upon story heights and the number of stories. A section of 305 mm x 305 mm (12 in. x 12 in.) is typically used for story heights of 3.05 m (10 ft) and 4.27 m (14 ft), and a section of 406 mm x 406 mm (16 in. x 16 in.) is employed for story heights of 5.5 m (18 ft) and 7.32 m (24 ft).

Beams Three types of beams are used with this system. Type "A" is an inverted tee beam, with horizontal openings of 711 mm x 356 mm (28 x 14-in.) on a 1.52 m (5 ft) module (Figure 3.6a). Spandrel beams, type "B", support tee slabs on one side and also include openings of 711 mm x 356 mm (28 in. x 14 in.) on a 1.52 m (5 ft) module. Type "C" primary beams, allow services to run over the beam and under the double tee floor slab. The result is an opening provided for the services of 1270 mm x 356 mm (50 in. x 14 in.) on a 1.52 m (5 ft) module (Figure 3.6b).

Floor units Double tee floor members are cast with blockouts to allow for horizontal passage of services. Tee slabs, 3.05 m wide x 813 mm (10 ft x 32 in.) deep, with a maximum span of 19.81 m (65 ft) incorporate 711 mm x 356 mm (28 x 14 in.) openings on a 1.52 m (5 ft) module (Figure 3.5). Dapped ends on the tee members also allows for the passage of horizontal service systems. To accommodate the vertical service systems, openings up to 1.22 m (4 ft) wide can be made through the deck of the double tees.

Structural description:

The Duotek structural system consists of three precast concrete structural elements: multi-story columns, prestressed beams, and prestressed tee slabs. The system can be used for structures up to 5 stories in height. Cast-in-place concrete is used for beam-to-column connections to achieve a monolithic joint. Additional connection details were not available. A cast-in-place structural concrete topping, 63 mm (2-1/2 in.) thick, is placed to complete the floor system.

Structural bay sizes vary in 1.52 m (5 ft) modular increments up to 9.15 x 19.81 m (30 x 65 ft). Roof spans can be up to 24.4 m (80 ft). Story heights available are 3.05, 4.27, 5.5, and 7.32 m (10, 14, 18, and 24 ft). The structural floor system has a depth of 1016 mm (40 in.).

Construction sequence:

Details not available.

Incorporation of HVAC, plumbing, and electrical systems:

This system provides for full accommodation of building services and components. The slotted openings for HVAC and plumbing services in beams and tee slabs provide maximum flexibility for initial requirements and future modifications. Typical primary beams include 711 x 356 mm (28 x 14 in.) openings on a 1.52 m (5 ft) module. The floor system has a total depth of 1.22 m (4-ft). This depth accommodates the precast structural members, the HVAC, plumbing, and electrical services, and the ceiling and lighting system.

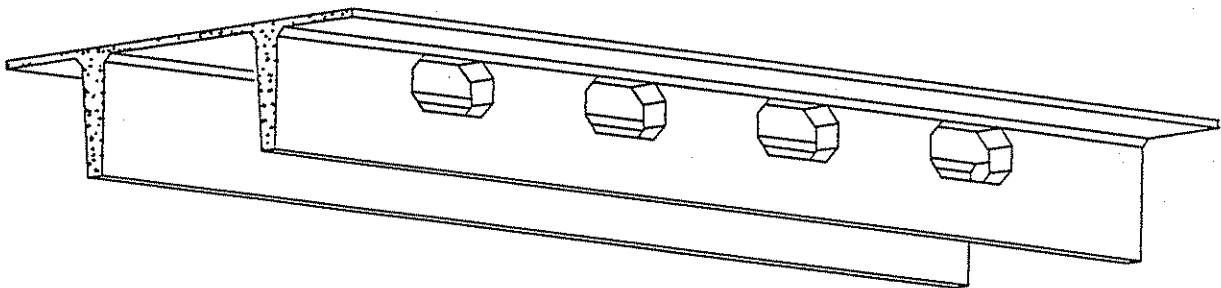
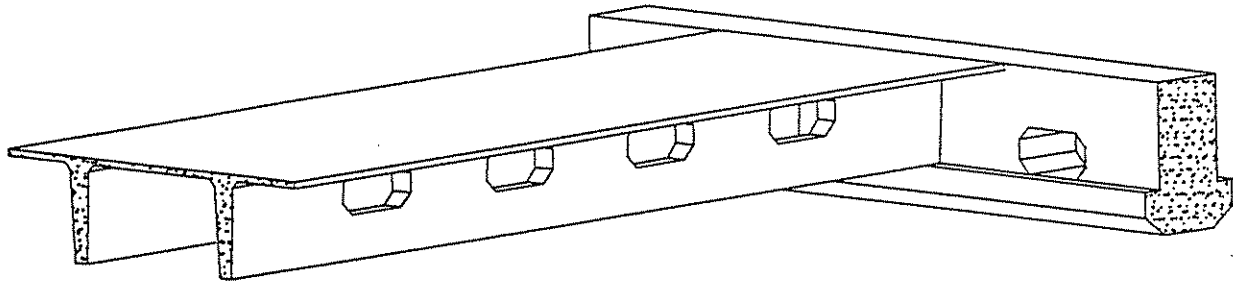
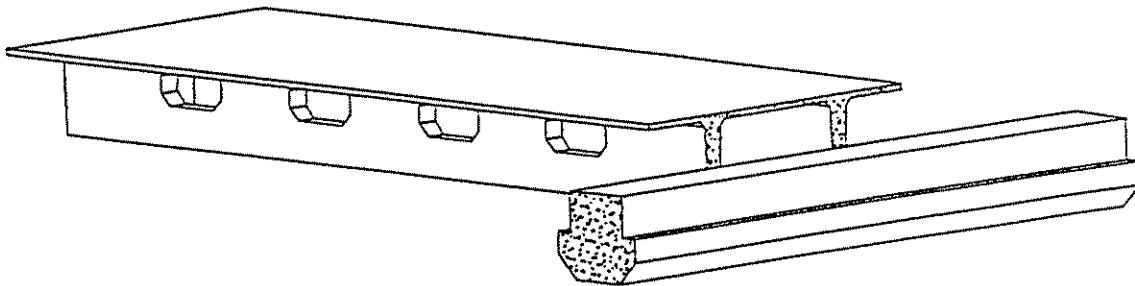

Figure 3.5. Precast double tees with 711 mm x 356 mm (28 in. x 14 in.) stem openings on a 1.52 m (5 ft) module.



(a)



(b)

Figure 3.6. Precast primary beams with web openings: a) Inverted tee beam (Type A) with 711 mm x 356 mm (28 in. x 14 in.) openings on a 1.52 m (5 ft) module; b) Partial inverted tee beams (Type C) with 1270 mm x 356 mm (50 in. x 14 in.) openings on a 1.52 m (5 ft) module.

3.2.3 Dycore System

Developer: Finfrook Industries, Inc.
P.O. Box 607754
Orlando, FL 32860-7754
United States

Overview:

The key precast elements include shallow soffit beams, high strength Dycore floor slabs, and multi-story columns cast with blockouts at the beam level (Figure 3.7). The precast beam and floor members serve as stay-in-place forms for composite cast-in-place concrete. Connections are also composed of cast-in-place concrete. Finfrook Industries [1992] indicated that for spans over 7.62 m (25 ft), a 508 mm (20 in.) structural floor depth is required for office loading. This depth is comprised of a 305 mm (12 in.) precast soffit beam and a 203 mm (8 in.) Dycore floor slab.

This structural system has been used throughout the United States for office structures, schools, health care facilities, and parking garages [Finfrook Industries 1992].

Precast components:

Columns Columns may be cast-in-place or precast, with multi-story precast columns containing blockout cavities at the beam level, to facilitate beam-to-column connections. Columns can be cast up to four stories in length [Finfrook Industries 1992].

Beams Interior soffit beams with protruding shear reinforcement are cast as shallow members to act as stay-in-place forms for cast-in-place concrete. Interior soffit beams are 1.2 m (4 ft) wide and similar in configuration to Dycore hollow-core floor planks, but the soffit beams are solid without voids. Beams are manufactured with 41.4 MPa (6000 psi) concrete and topped with composite cast-in-place concrete of 31 MPa (4500 psi) compressive strength [Finfrook Industries 1992].

Floor units Dycore hollow-core planks are used as floor units. These precast, prestressed floor units are manufactured with normal weight, 55 MPa (8000 psi) concrete. Floor units are typically manufactured with a width of 1.2 m (4 ft) [Finfrook Industries 1992].

Structural description:

Precast columns, fabricated with blockouts for beam-to-column connections, are combined with partially precast soffit beams and cast-in-place concrete to produce a rigid monolithic frame. Negative moment beam reinforcement is tied to the precast soffit beam and to the column reinforcement. Cast-in-place concrete then embeds all of the reinforcement. Floor units are tied together with grout which is applied in shear keys of adjacent floor units.

The system has a relatively high span-to-depth ratio (15-to-20), and is typically used in multi-story commercial buildings or parking structures where large bay sizes are required. Finfrook Industries indicated that the minimum structural depth of the floor system for a 7.62 m

(25 ft) span is 508 mm (20 in.). The soffit beam would require 305 mm (12 in.) and the floor slab would require 203 mm (8 in.). This depth does not include the additional depth which is required for HVAC, plumbing, and electrical services.

Construction sequence:

- Multi-story precast columns are erected on the foundation and temporarily braced. Reinforcing bars extend through the column cavities at the beam level, and protrude from the top of the column if additional stories are being constructed.

- Interior and exterior soffit beams are positioned between columns and placed on temporary steel shoring. Typical shoring would be located at the quarter points along the span.

- Dycore slabs are placed on the interior soffit beams, and the shear keys between the slabs are grouted. If electrical components are to be installed within the cellular raceways of the hollow-core planks, and within the composite cast-in-place concrete, then electrical conduit is placed at this time. The conduit is placed on the precast soffit beam, between each end of the floor planks. Bulkheads are placed in Dycore plank cavities to maintain the voids in the planks.

- Longitudinal reinforcing steel is placed on the precast interior soffit beams and through the column cavity to provide continuity. Similar reinforcement is used for exterior soffits. Stirrups protruding from the top surface of the soffit beam are tied to the longitudinal reinforcement.

- Temporary formwork is required around the outside edge of the exterior soffit beams, and minor formwork is required around the columns.

- Concrete is cast on the interior soffit beams and on the exterior soffit beams at the edges of the deck. The concrete is cast flush with the top of the Dycore planks, producing a level floor surface.

- Shoring can be removed once the composite cast-in-place concrete reaches the required strength, but would remain in place if construction on the next floor begins immediately.

Incorporation of HVAC, plumbing, and electrical systems:

HVAC, plumbing, and electrical systems can be placed on the precast soffit and embedded in the composite cast-in-place concrete. Similarly, voids in Dycore slabs can be used to house electrical and plumbing components. HVAC and plumbing services are typically suspended beneath the precast floor system with standard manufactured hardware. Blockouts can be cast in Dycore floor units to allow for vertical passage of HVAC and plumbing systems. Holes can also be drilled in the floor members after they are erected.

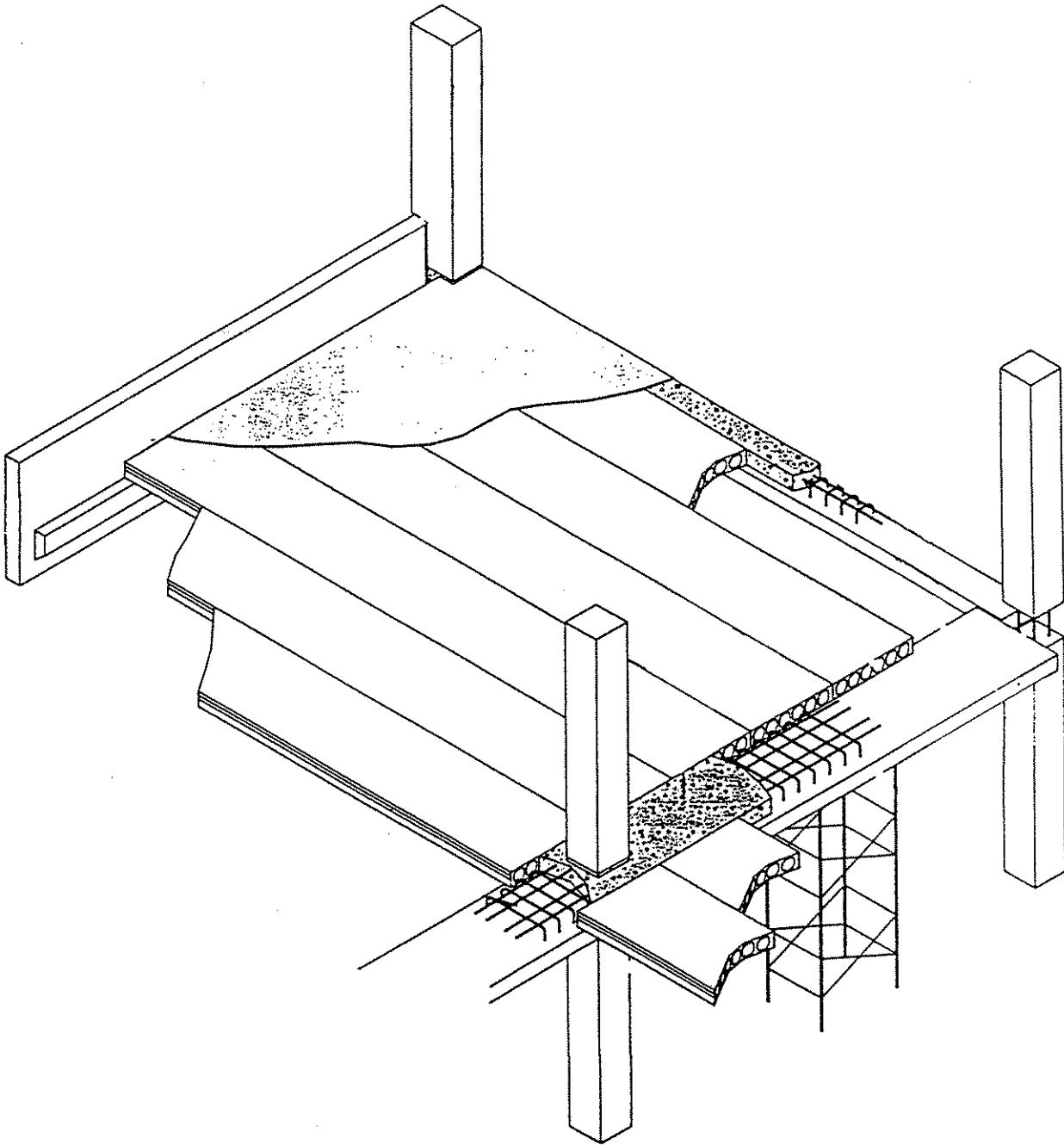

Figure 3.7. Composite Dycore structural system [adapted from Finfrock Industries 1992].

3.2.4 Dyna-frame System

Developer: Flexicore Systems, Inc.
7941 New Carlisle Pike
Huber Heights, OH 45424
United States

Overview:

The key to this system is the column-to-column splice and the column-to-beam splice. The highly standardized connections do not change as the design loads for the structure increase. The system employs single story precast columns, with precast soffit beams and floor planks which act as stay-in-place forms for cast-in-place concrete. Beams do not frame into the columns, but simply slip onto them, with the beam splices occurring not at the column but at the points of inflection. According to Strescon Industries [Strescon Industries], a 7.3 m (24 ft) span with office loading requires a 711 mm (28 in.) deep precast floor system.

Price Brothers Co. and now Flexicore Systems, Inc. have been producing and erecting Dyna-frame structures since 1969. Flexicore Systems, Inc. indicated that approximately 3.5 million square feet of Dyna-frame buildings and garages have been erected in the United States. Dyna-frame was originally used in the Baltimore-Washington area by Strescon Industries, Inc. [Perry 1967]. The system is typically used in multi-story residential structures, office buildings, parking garages, and schools.

Precast components:

Columns Single story precast columns are pretensioned with three 6 mm (1/4 in.) prestressing strands, and reinforced with a hot-rolled, seamless structural steel tube running longitudinally in the center of the column. The tube does not protrude from either end of the column. The inside diameter of this tube or column core is held constant at 100 mm (4 in.). The columns are always a single story in length, making it necessary to have a column splice at each floor. Columns have a concrete compressive strength of 27.6 MPa (4000 psi) at initial prestress with a 28 day strength of 41.4 MPa (6000 psi) [Flexicore Systems 1992].

Beams Floor and roof beams are always supported directly by single story columns, and are never framed into them. This enables a beam to be designed as a simple span, a multi-span, or a cantilevered beam with beam splices at the points of inflection. Beam sleeves, 152 mm (6 in.) in diameter, are cast in the beam to be concentric with the steel core of the supporting column as shown in Figure 3.9. In general the beams are designed as composite members. Beams have a 24.1 MPa (3500 psi) minimum compressive strength at time of initial prestress, and a 34.5 MPa (5000 psi) minimum at 28 days [Flexicore Systems 1992].

Flooring units Flexicore hollow-core floor planks are used with this system. The Flexicore planks are available in four basic thicknesses: 150, 200, 250, and 300 mm (6, 8, 10, and 12 in.). A 9.1 m (30 ft) span subject to a live load of 3.35 kN/m² (70 psf) would require a 250 mm (10 in.) deep floor unit [Price Brothers 1989].

Structural description:

Dyna-frame is a composite structural system, utilizing precast, prestressed beams and columns. The key to the system is the method of joining the single story precast concrete columns. Interaction curves have been developed for 305 mm x 305 mm (12 in. x 12 in.), 406 mm x 406 mm (16 in. x 16 in.), 508 mm x 508 mm (20 in. x 20 in.), and 610 mm x 610 mm (24 in. x 24 in.) columns for a broad range of core sizes. Validity of the column design was verified by a testing program on full sized columns at Lehigh University in 1966.

Beams can be single span, multi-span, or cantilevered with beam splices at natural points of inflection. The beams are supported directly by single story columns and are never framed into them, permitting the designer some freedom in beam configuration. The beams are designed as composite members. The precast portion is designed to take the erection loads of the floor plank, concrete topping, and its own self weight for both negative and positive moments. The complete beam, including 31 MPa (4500 psi) cast-in-place concrete and field placed reinforcing carries the service loads. Mild steel reinforcing is field placed over the column to carry the negative moment imposed on the beam by service loads. If cantilevered beams are used, then a beam-to-beam splice is required. Steel connection angles, located in the cast-in-place top portion of the beam, provide the connection (Figure 3.8). Mild steel negative moment reinforcing is extended through this joint to ensure an adequate tie between the beams, but no attempt is made to transfer moment through this connection [Perry 1967].

Strescon Industries, Inc. [Strescon Industries] indicated that for office loading, a span of 7.3 m (24 ft) would require a 711 mm (28 in.) deep precast floor system. This depth is comprised of a 508 mm (20 in.) rectangular beam and a 203 mm (8 in.) precast hollow-core plank.

Construction sequence:

·A 100 mm (4 in.) diameter steel tube (footing spindle) is cast into the concrete footing so it protrudes upward (Figure 3.10). A short length of tubing, called the collar, is threaded down over this piece of steel pipe. The collar is adjusted to the proper elevation and the column is slipped down over the steel tube until the bottom of the core bears on the top of the collar.

·The steel tube from the footing projects about a foot up into the core of the column. The column remains in this condition until the framing of the floor above has been set, then the bottom of the column is dry-packed with a non-shrink grout to complete the connection.

·An aluminum cone is set on top of the column and the beam is lowered over the cone. The cone guides the beam into the proper position on the column. The diameter of the base of the cone is about 2 mm (1/16 in.) less than the diameter of the beam sleeve, allowing the cone to be pulled up through the beam sleeve, once the beam has been seated.

·A beam-to-beam connection may be required if a multi-bay structure is being erected. Lateral alignment of the connection is achieved with pinch bars, and vertical adjustment with the nuts on the load support bolts of the connection.

·Hollow-core floor planks are placed on the precast soffit beams and shear keys are grouted.

·A piece of short steel tubing (spindle), with a steel collar, is slipped into the core of the lower column. The collar prevents the spindle from slipping all the way down the column.

·Grout is poured down through the beam sleeve and flows out into the space between the bottom of the beam and the top of the column. A small vent tube is located in each corner of the gasket to allow the trapped air to escape.

·The bottom of the lower column is grouted at this time.

·Erection proceeds with the upper column slipping over the spindle and the next level of beams and floor planks placed. Composite cast-in-place concrete is placed for the beams and the steel beam-to-beam connection is covered. A structural cast-in-place concrete floor topping of 76 mm (3 in.) is placed.

Incorporation of HVAC, plumbing, and electrical systems:

Accommodation of the horizontal service systems is possible with the Dyna-frame system, if cantilevered beams are employed. As shown in Figure 3.11, the interior soffit beam does not extend across the full span. This allows for HVAC, plumbing, and electrical components to be suspended without increasing the total depth of the floor system. The service components can be fastened to the precast elements with standard hardware.

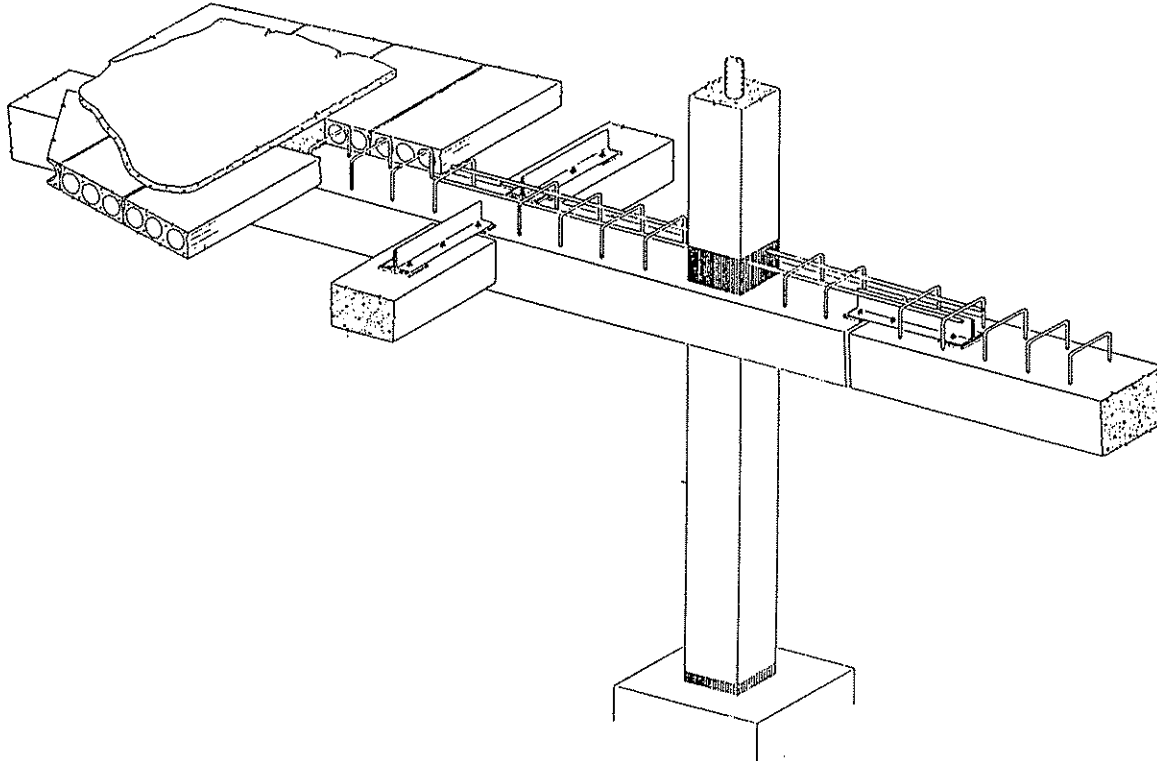

Figure 3.8. Dyna-frame structural components [adapted from Flexicore Systems 1992].

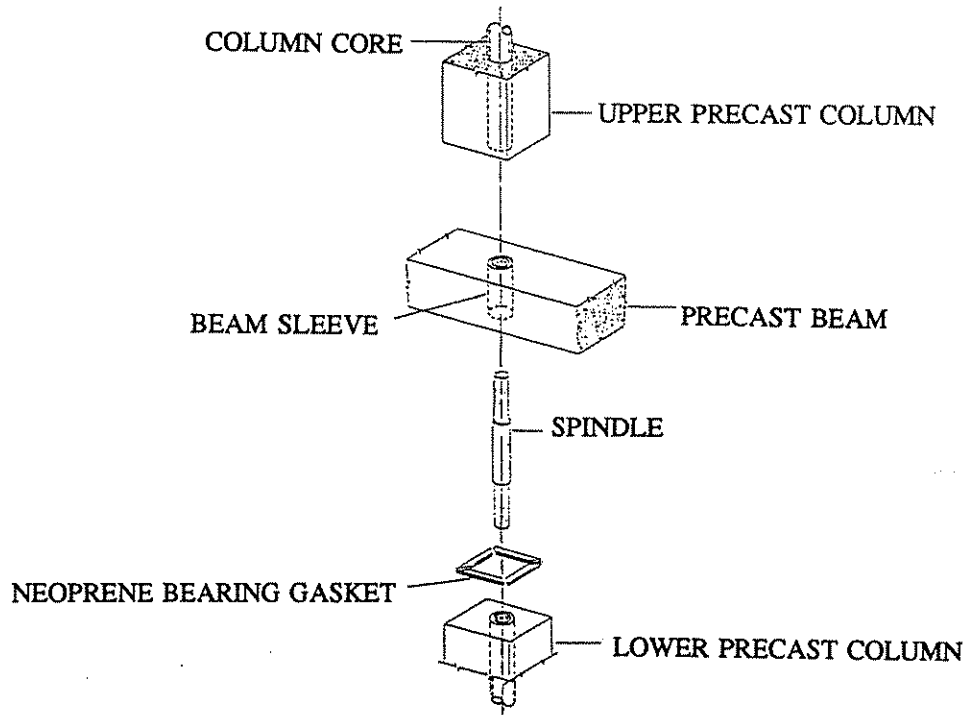

Figure 3.9. Detail showing column-to-beam connection [adapted from Flexicore Systems 1992].

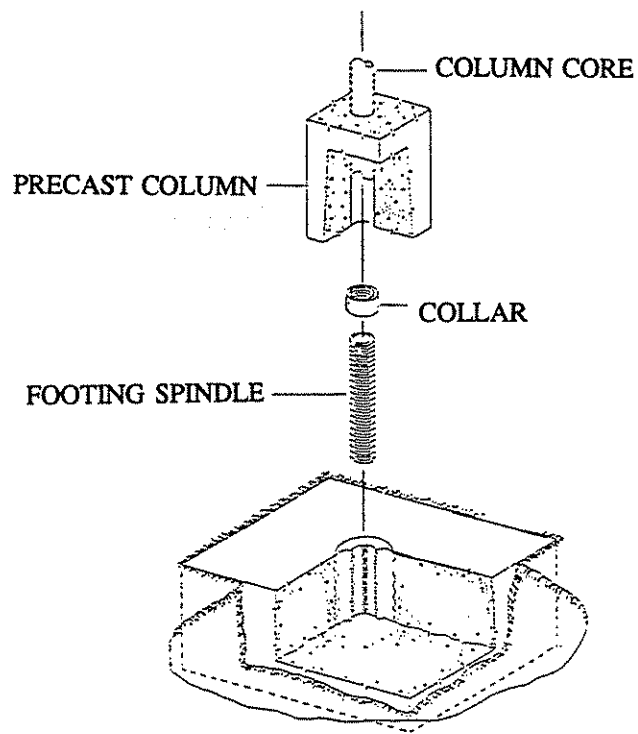

Figure 3.10. Detail showing column footing [adapted from Flexicore Systems 1992].

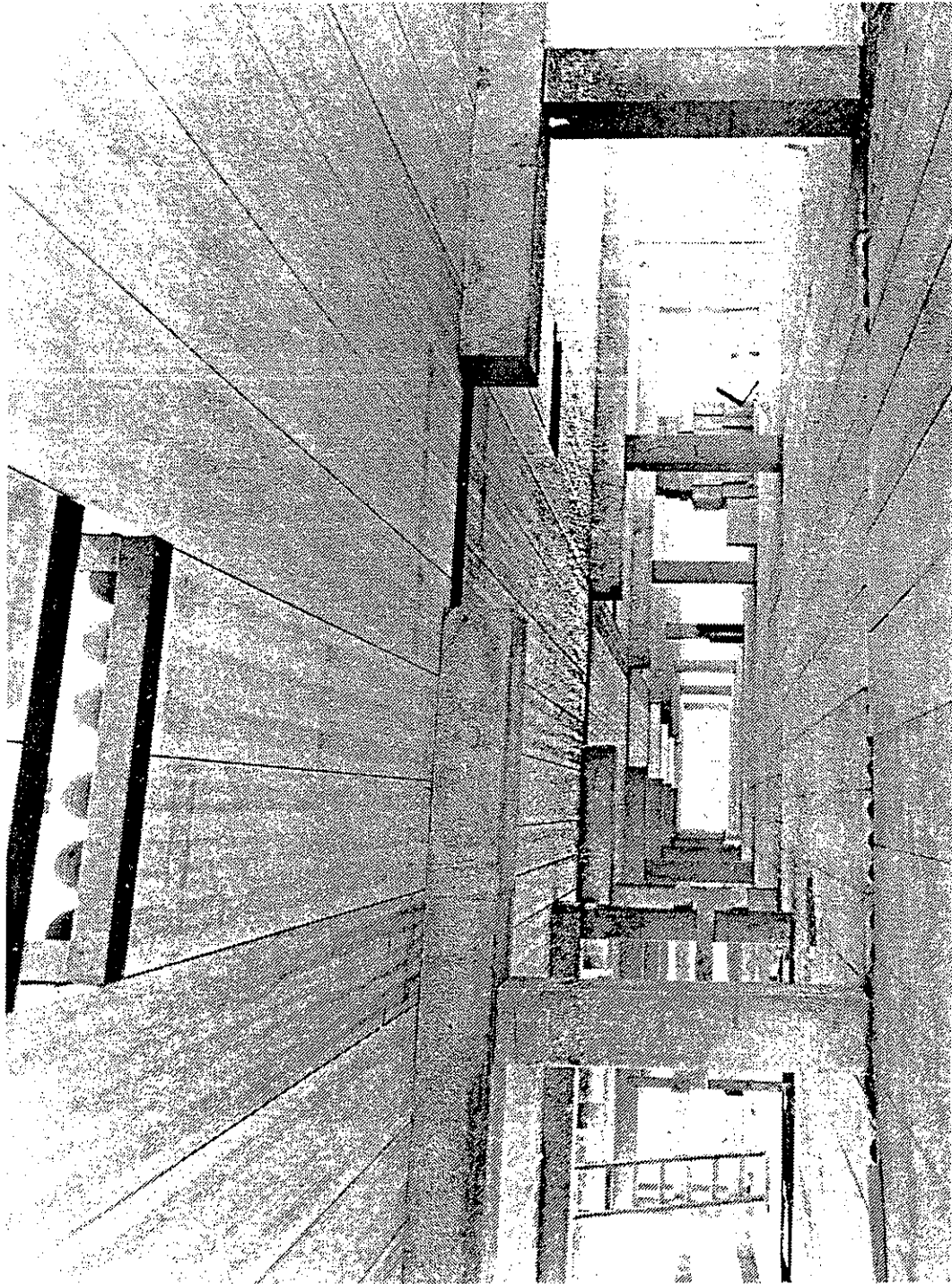

Figure 3.11. Accommodation of services by using cantilevered beams [Perry 1967].

3.2.5 Filigree Method of Construction

The four structural systems described in this section all utilize Filigree precast slabs for floor members. Filigree construction employs reinforced precast floor panels which serve as permanent formwork. The precast panels are composite with cast-in-place concrete and contain the reinforcement required in the bottom portion of the slab. They also contain a steel triangulated lattice truss, which projects from the top of the precast unit (Figure 3.12). The steel truss ensures composite behavior between precast and cast-in-place concrete, and provides the unit with its stiffness during erection. The system can be used in bearing wall, column and beam, and flat plate construction.

This method of construction is used throughout the United States, and a complete description of the Filigree Wideslab method of construction is provided in section 3.2.5.1. Filigree construction is also used widely in Japan. Sections 3.2.5.2, 3.2.5.3, and 3.2.5.4 provide a brief overview of three structural systems which are typical of precast construction in Japan today. Information on precast structural systems developed in Japan was taken from a report produced by the Joint Technical Coordinating Committee on Precast Seismic Structural Systems [Yoshizaki 1990]. The report entitled "Existing Precast Frame Systems In Japan", describes the state-of-practice of precast seismic structural systems in Japan, and surveys existing precast frame buildings with respect to their use, scale, structural system, and structural connections.

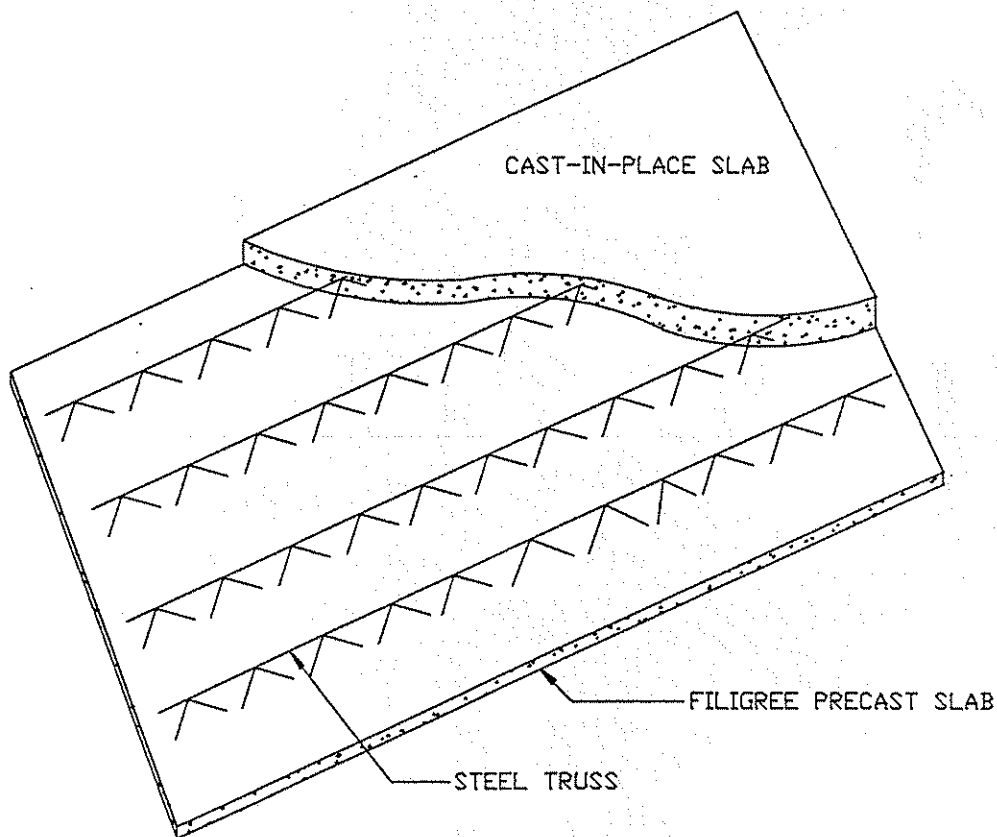

Figure 3.12 Precast slab with light steel truss.

3.2.5.1 Filigree Wideslab System

Developer: Mid-State Filigree Systems, Inc.
Brickyard Rd.
P.O. Box 435
Cranbury, NJ 08512
United States

Overview:

This method of construction is used throughout the United States. Mid-State Filigree Systems, Inc. has produced Filigree slabs since 1972. The system, however, was originally developed in Great Britain, and is presently used there under the name of OMNIDEC [Omnia Concrete Floors 1988]. Though often used for parking garages, the system has also been used in multi-story residential construction, multi-story office buildings, and other multi-story administrative and commercial structures.

Precast components:

Beams Both cast-in-place and precast soffit beams are used with this system. Mid-State Filigree Systems manufactures a wide, shallow, interior soffit beam, which is 63.5 mm (2-1/2 in.) deep. These beams are typically designed for medium range spans 4.57-7.62 m (15-25 ft) [Mid-State Filigree Systems 1992]. Beams can also be cast with voids to increase structural efficiency.

Floor units Filigree wideslabs are thin, semi-finished, precast concrete slabs, with a triangulated steel truss protruding from the top (Figure 3.12). The typical thickness of the prefabricated unit is 57 mm (2-1/4 in.). The units are custom made with lengths up to 21 m (70 ft) possible, and typical widths of 2.44 m (8 ft) or less. Slab units can be pretensioned, so when top reinforcing and cast-in-place concrete is placed, the resulting floor is camber free. The prestressing steel used in Filigree wideslabs is 9 mm (3/8 in.) diameter, 1860 MPa (270 ksi) or 1720 MPa (250 ksi) seven wire, uncoated, stress relieved strands.

A variation to the solid Filigree unit described above is the Filigree voided wideslab unit. Lightweight void formers, typically expanded polystyrene, are pressed into the top surface of the precast unit during manufacture. The performance of the floor unit can be varied considerably by varying the height, width, or length of the void formers. Void formers may be omitted close to the supports to provide for continuous design or to increase the shear potential of the floor unit [Mid-State Filigree Systems 1992].

Structural description:

The floor system consists of a thin, prefabricated slab unit, which is placed on a precast or cast-in-place interior soffit beam. Soffit beams are supported by cast-in-place single story columns. A light steel truss is cast into the precast unit to ensure rigidity of the unit during construction, and to provide composite action between the precast unit and cast-in-place concrete. The prefabricated unit is designed as a simply supported member. Field placed negative moment reinforcement provides continuity between floor units, soffit beams, and cast-in-place columns,

and combines with cast-in-place connections to create a frame which acts monolithically under gravity forces.

The system can be used in bearing wall, column and beam, and flat plate construction. For spans of less than 7.3 m (24 ft), flat plate construction is employed, eliminating the extra depth which is required for beams. The system is typically used for parking garage construction where spans are large and the loading is relatively light. According to Mid-State Filigree, for a span of 11 m (36 ft) and a load of 2.39 kN/m² (50 psf), a structural depth of 330 mm (13 in.) would be required. Spans of up to 19.5 m (64 ft) can be achieved in parking garages. The structural floor depth would be approximately 660 mm (26 in.) [Mid-State Filigree Systems 1992].

Construction sequence:

·Column reinforcing bars are tied into the foundation or floor below. Formwork for cast-in-place columns is constructed and braced.

·Interior and exterior soffit beams are positioned between columns on temporary steel shoring. Formwork is built up around the beam-to-column connection.

·Prefabricated floor units are placed spanning between soffit beams. The floor units are usually propped with temporary steel shoring.

·Electrical services, which will be embedded in the cast-in-place concrete, can be placed. If additional vertical holes are required for services, they are drilled now.

·Negative moment reinforcement is placed on the floor units, over the soffit beam, and over the column support, to provide structural continuity. A wire mesh can also be placed over the entire floor system to provide continuity, and control cracking.

·Concrete is placed and finished. Construction on the next floor does not begin until the concrete has reached the required strength. The field shoring is not removed until construction is complete.

Incorporation of HVAC, plumbing, and electrical systems:

Electrical services can be placed within the cast-in-place portion of the floor system. Preformed holes, pre-positioned junction boxes and attachment hardware are all available from the manufacturer. HVAC system components are suspended beneath the precast floor components and passed vertically through preformed blockouts in the floor units.

3.2.5.2 PG Connection System

Developer: Obayashi Corporation Technical Research Institute
4-640, Shimokiyoto, Kiyose-shi, Tokyo 204
Japan

Overview:

The PG Connection system employs precast cross-shaped beam components which are placed at column locations. As shown in Figure 3.13, the precast cross-beam or cruciform element is placed over the column. The column is cast-in-place. The floor slab is a two part unit consisting of a slab which serves as a form for the second component, the structural concrete topping.

Columns are cast-in-place with steel reinforcing bars protruding from their upper face. Beam components are prefabricated with vertical holes to allow column bars to be passed through. High strength grout is pumped between the column and beam, and in the vertical anchor holes to tie the system together. The beam-to-beam connection can be made by welding or employing a mechanical splice. Formwork is built up around the connection and the beam is completed with cast-in-place concrete. In locating the beam-to-beam joint outside of the high stressed beam-to-column area, performance of the structure as a cast-in-place reinforced concrete structure can be ensured.

The system has been used in the construction of multi-story office and apartment buildings.

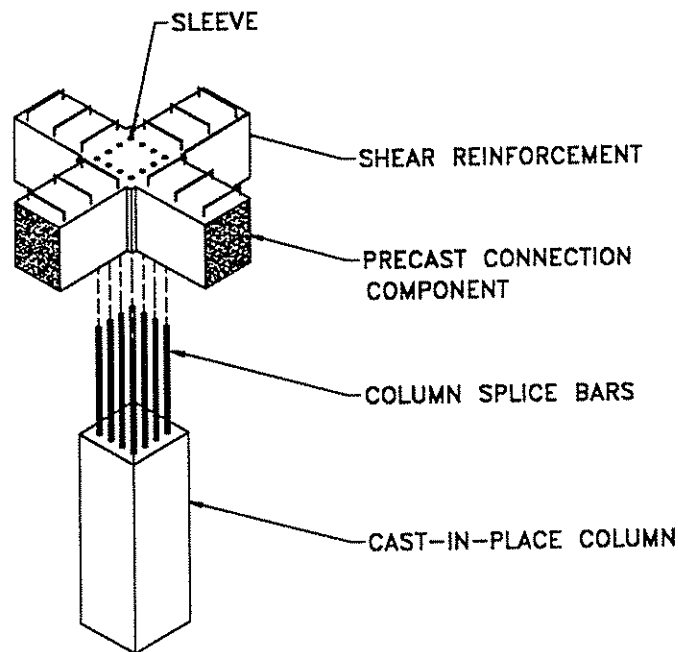

Figure 3.13. Cross-shaped beam-to-column component.

3.2.5.3 RC Layered Construction System

Developer: Taisei Corporation
Technology Research Center
344-1, Nase-machi, Totsuka-ku
Yokohama 245
Japan

Overview:

The structural system consists of single span members connected monolithically with cast-in-place concrete. Components of the system include precast single story columns, precast beams, and Filigree type slabs.

Single story columns are cast with reinforcing bars protruding from their upper face to facilitate the column-to-column connection. Single span beam members rest on the precast columns. Once the thin precast slabs are positioned, negative moment steel is placed. Reinforcement is placed longitudinally along the top of the beam and through the beam-to-column connection zone. Two way reinforcement is placed on the precast floor slab. The concrete structural topping is placed over the entire floor system, resulting in monolithic connections. Construction of subsequent stories begins with precast columns being slipped over the protruding anchor bars from the lower column. The connection is then grouted.

This system has been used since 1978. In the twelve years since its first implementation, 38 buildings have been constructed in Japan by the RC Layered Construction System. Among those structures are apartment buildings, multi-story office buildings, and department stores.

3.2.5.4 RPC-K System

Developer: Kabuki Construction Co., Ltd.
Technical Research Institute
Takeda 3-31-5
Toshima, Tokyo
Japan

Overview:

This system can be characterized as a "shell" system. The precast beams are U shaped and serve as stay-in-place forms/shells for cast-in-place concrete (Figure 3.14). Longitudinal beam reinforcement and shear reinforcement are embedded in the precast portion of the beam. Additional negative moment steel is placed in the trough of the beam once the beam is in place. Reinforced concrete columns are cast-in-place.

Cast-in-place concrete is used for all connections between components. Bottom reinforcement which protrudes from the precast portion of the beam is bent upward to provide anchorage. The reinforcement is designed to pass across two-thirds of the column section before being bent upward. To facilitate the column-to-column connection, main reinforcement from cast-in-place lower columns protrudes upward to tie in the cast-in-place upper column. Precast floor planks rest on top of the precast portion of the beam and reinforcement is placed across the trough of the beam to tie the components together. Negative moment reinforcing steel is placed both longitudinally and transversely on the precast slab, and then embedded with the cast-in-place concrete.

The combination of partially precast components with cast-in-place connections results in a monolithic reinforced concrete frame. This system is suitable for the construction of offices, schools, apartment buildings, hotels, and shopping centers. The developer claims a reduction in labor costs with the system when compared to an entirely cast-in-place system.

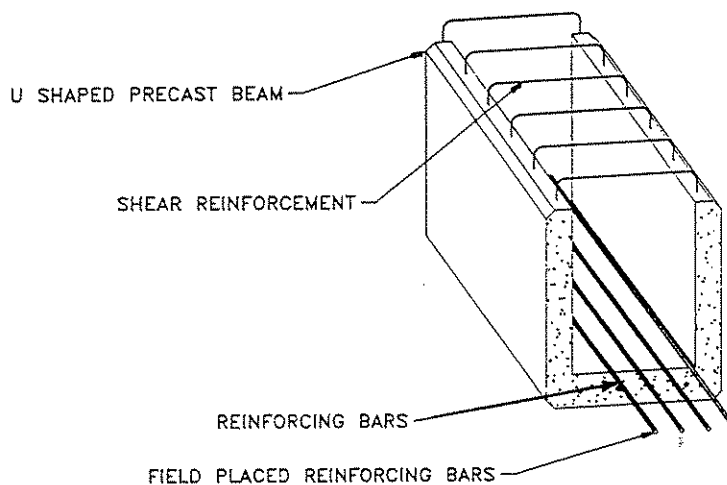

Figure 3.14. U shaped precast shell beam.

3.2.6 IMS System

Developer: State Building Co. of Baranya County
Hungary

Overview:

The philosophy behind the IMS System is to provide an open, prefabricated framework, suitable for both commercial and residential buildings, allowing for flexibility of layout. The key precast element of this modular system is the pretensioned floor unit which is manufactured in two phases. The structural system relies on the principle that the load from the floor unit is transferred to the columns through friction produced by post-tensioning cables. Load capacity of the floor system can be varied by varying the grade of post-tensioning, while using the same structural members.

The IMS system, also known as the IMS-ZEZELJ system, originated in Serbia, Yugoslavia at the Institute for Testing of Materials [Petrovic 1978]. The system was developed in the early 1950's. Because of the ability of the system to withstand seismic forces, it has gained acceptance in regions of frequent seismic activity. The State Building Co. of Baranya County (BEV), Hungary, has further developed the system to obtain longer spans, and to provide for greater flexibility in accommodating utilities. The system has been used in Cuba, Hungary, and Yugoslavia, for the construction of schools, hospitals, administrative buildings, offices, and hotels [Fogarasi 1986].

Precast components:

Columns Columns range in height from 1 to 3 stories with a maximum length of approximately 12 m (40 ft). The cross-section is typically square with dimensions of 400 mm x 400 mm (16 x 16 in.).

Floor units Floor units are manufactured in two phases. In phase one, the unit is cast as a ribbed unit with a top flange. The reinforced ribbed slab is externally prestressed to produce compression in the top flange, and tension in the bottom portion of the ribs. In phase two, the bottom of the floor is equipped with a wire mesh, and immersed in fresh concrete. Once the fresh concrete has gained adequate strength, external stress is released from the ribbed unit, producing compression in both the top and bottom flanges, and tension in the ribs. The floor unit is flat on both top and bottom faces. Floor units are manufactured in the following sizes:

Single-unit systems (See Figure 3.15a):

- 3.6 x 3.6 m (12 x 12 ft)
- 3.6 x 4.8 m (12 x 16 ft)
- 3.6 x 6.0 m (12 x 20 ft)

Two-unit systems (See Figure 3.15b):

- 2.4 x 6.0 m (8 x 20 ft)
- 3.0 x 6.0 m (10 x 20 ft)
- 3.6 x 6.0 m (12 x 20 ft)

Four-unit systems (See Figure 3.15c):

- 3.0 x 3.0 m (10 x 10 ft)
- 3.6 x 3.6 m (12 x 12 ft)

Edge beams With post-tensioning, the precast edge beams become main girders of the structural floor system.

Structural description:

The IMS system relies on post-tensioning to transfer vertical loads and bending moments from floor units and edge beams to the columns. These prestressing cables run through the columns and within the gap left between floor units. Load bearing capacity and stability are provided for by post-tensioning in the floor planes in both principal directions. In single-unit systems (Figure 3.15a), the prestressing cables are laid between floor units, but in multi-unit systems (Figures 3.15b and 3.15c) the cables are also passed through ducts within the floor units.

The geometric dimensions of floor units are standard and do not change as the load and span increases. The grade of prestressing is increased to compensate for the extra span length or load. Additional design information was not available for the system.

Construction sequence:

·Columns are precast in one, two, or three story lengths. The column footing stump is typically 400 mm (16 in.) square in cross section, and 1.0 m (3.3 ft) high. Reinforcement bars protrude 870 mm (34 in.) from the top of the column footing stump. The upper column contains a set of 900 mm (35 in.) deep holes to take the bars from the column footing stump. At floor level, a group of 4-6 holes in the column allow for prestressing cables to pass [Fogarasi 1986].

·Temporary steel collars or angles are mounted to the column with steel pins. The pins slip through holes which are cast into the column.

·Floor units are placed between the columns, and they are supported by the steel brackets. A groove or channel is left between adjacent floor units (Figure 3.16).

·Tendons are placed in straight lines into the channels across several floor units and prestressed. Eccentricity of these tendons is achieved by depressing them at points to more effectively conform with bending moments. For multi-unit floor systems, the prestressing cables are also threaded through the inner ducts and post-tensioned [Fogarasi 1986].

·After prestressing, the groove between floor units is filled with concrete, and in multi-unit systems, the inner ducts are filled with grout to bond the cables and floor units and for corrosion protection.

·Once the grout has reached sufficient strength the column collars can be removed and used for the floor above.

Incorporation of HVAC, plumbing, and electrical systems:

HVAC, plumbing, and electrical systems are suspended beneath the precast floor system and fastened with standard hardware. Passage of vertical ducts and plumbing is accommodated using blockouts during the casting of floor units.

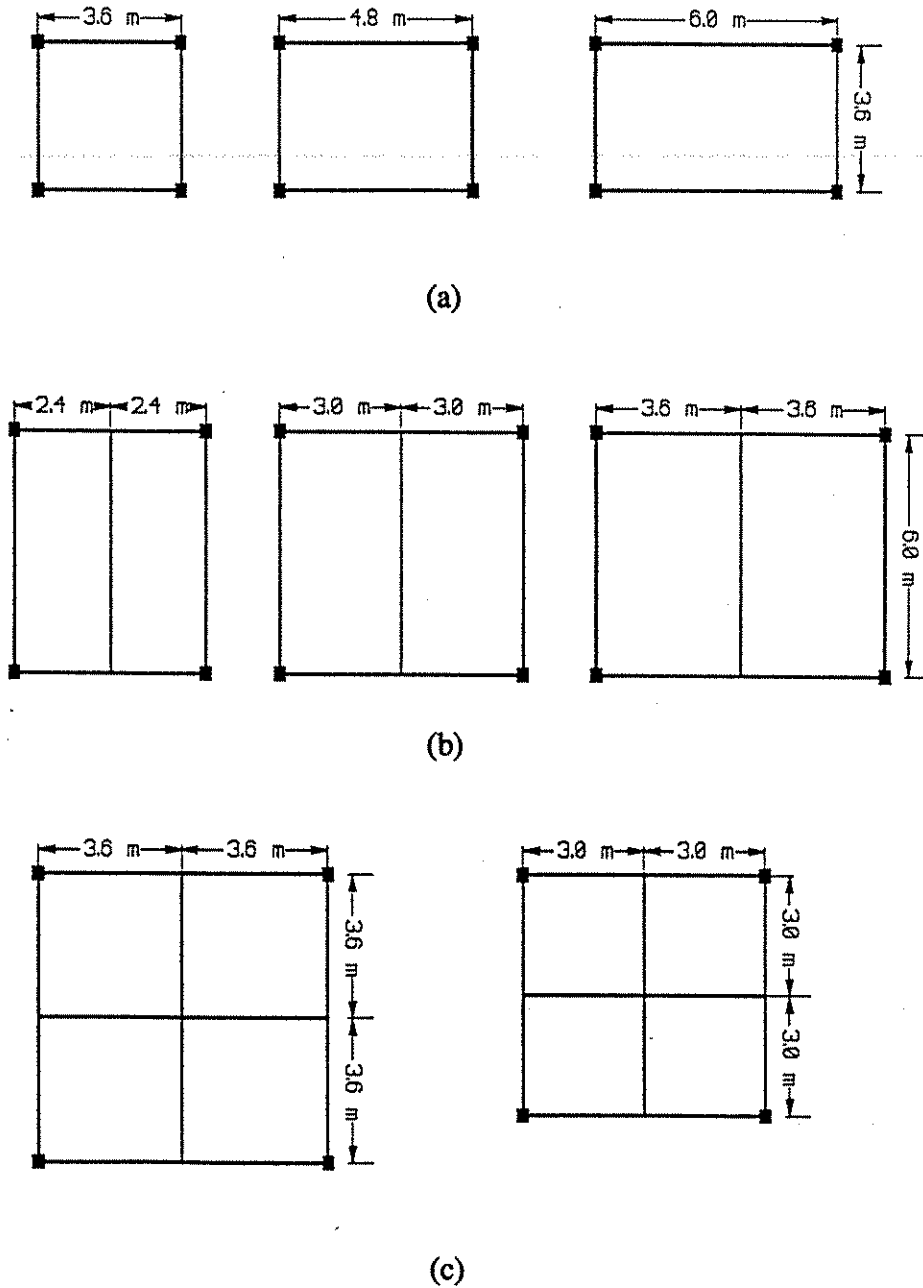

Figure 3.15. Modular composition possibilities for the IMS system: a) Single-unit systems 3.6 x 3.6 m, 4.8 x 3.6 m, or 6.0 x 3.6 m; b) Two-unit systems 2.4 x 6.0 m, 3.0 x 6.0 m, or 3.6 x 6.0 m; c) Four-unit systems 3.6 x 3.6 m, or 3.0 x 3.0 m.

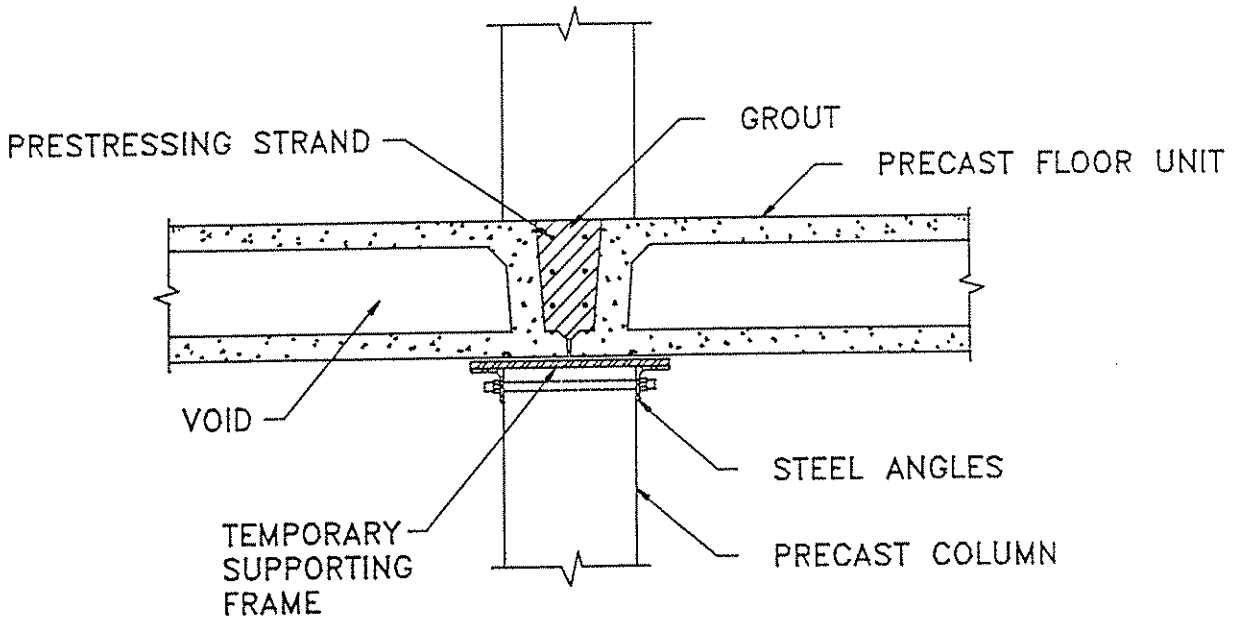

Figure 3.16. Joint between floor units and column during construction.

3.2.7 PD2 Frame System

Developer: Bison Concrete Limited
Thorney Lane, Iver
Buckinghamshire SL0 9HQ
Great Britain

Overview:

PD2 Frame is a precast concrete structural system with a planning module of 0.3 m (1 ft) and a maximum bay size of 10.8 m x 7.2 m (36 ft x 24 ft). It is intended primarily for structures of 1 to 4 stories, but can be extended to greater heights. The aim of the system is to use a limited number of different precast components. These components are designed on a module of 100 mm (4 in.). The system also employs precast cladding as a structural component of the frame. Provision is made to allow services to pass through notched primary beams. The structural depth of the precast floor system for a 7.2 m (24 ft) span under office loading is 645 mm (25.5 in.).

The PD Frame was implemented in 1960. The PD2 Frame was developed in 1972 based on the practical knowledge gained from the original system. Bison Concrete [1970] indicated that the structural system has proven to be economical in Great Britain for various building types. Schools, offices, hospitals, shops, and factories of up to four stories have been constructed with the structural system. An adaption to the system can be provided for recreational facilities, assembly halls, and other tall single story buildings with long spans [Bison Concrete 1970].

Precast components:

Columns Typically cast in one length up to four stories in height, columns are prestressed or reinforced with mild steel depending on loading conditions. Standard columns are 290 mm x 290 mm (11.5 in. x 11.5 in.) in section. Columns are cast with short steel tees at the beam level to facilitate the beam-to-column connection (Figure 3.17).

Beams Prestressed inverted tee beams serve as primary beams, and L shaped precast members act as spandrel beams. Both types of beams are cast with steel plates protruding from the end faces of the member. These plates are bolted to steel plates that are cast in the columns.

Floor units Floor construction commonly consists of hollow prestressed units with widths that coincide with the .3 m (1 ft) planning module. For a 318 mm (12.5 in.) deep slab, the weight of the floor is 3.65 kN/m² (75 psf) [Bison Concrete 1970].

Panels Load bearing panels can replace both columns and edge beams on the perimeter of the frame. The panels are manufactured in widths up to 3.6 m (12 ft) in increments of .3 m (1 ft). Thus two panels occupy the same space as the maximum column spacing of the PD2 Frame.

Standard story heights are 3 m (10 ft), 3.3 m (11 ft), and 3.6 m (12 ft), but for projects where repetition is on a large scale, other heights can be provided in increments of 100 mm (4 in.). The panels are 250 mm (10 in.) thick with 75 mm (3 in.) of external concrete, 25 mm (1 in.) of insulation, and 150 mm (6 in.) of internal load bearing concrete [Bison Concrete 1970].

Structural description:

The PD2 Frame system relies on precast concrete for all the key elements of the structural system and uses a small quantity of cast-in-place concrete for continuity between members and to protect steel connections from corrosion. The precast components of the system include the following: Multi-story columns, load bearing exterior panels, inverted tee beams, L shaped spandrel beams, and hollow-core floor planks. Column spacing is variable on a module of .3 m (1 ft), with centers on a grid up to a maximum of 10.8 m x 7.2 m (36 ft x 24 ft). The vertical module is also 300 mm (12 in.). Ground to first floor varies from 3 m (10 ft) to 4.8 m (16 ft), and the upper floors from 3 m (10 ft) to 3.6 m (12 ft) [Bison Concrete 1970].

The structural depth of the floor system for a 7.2 m (24 ft) span, and typical office loading is 645 mm (25.5 in.). An inverted T beam 645 mm (25.5 in.) deep is required for a 5 kN/m² (100 psf) load and a span of 7.2 m (24 ft). For a similar span and loading, a spandrel beam with a depth of 320 mm (12.5 in.) is required. Span/load data provided by Bison Concrete indicates that a 320 mm (12.5 in.) deep floor plank is required to support a 5 kN/m² (100 psf) superimposed live load for a span of 9.1 m (30 ft) [Bison Concrete 1970].

Construction sequence:

·In structures where multi-story columns are required, the column reinforcement is welded to a steel base plate which is bolted to the foundation. For single story structures, the columns can be set in foundation pockets, and once the column is aligned vertically, the pocket can be filled with cast-in-place concrete.

·Beams are placed between interior columns, and the steel plate component of the beam-to-column connection is aligned with the steel plate of the column. The connection is then bolted (Figure 3.17).

·The first level of load bearing wall exterior panels are placed on the building foundation. The panel is bolted to the foundation.

·Hollow-core planks are placed and steel reinforcement loops from the plank are tied to the beam reinforcement. For the structural connections between floor planks and wall members, steel loops projecting from the floor slabs are passed over vertical steel projecting from the wall units (Figure 3.17).

·Steel is placed horizontally in the gap between floor members and the web of the beam, and also through the wall panel-to-floor plank connection.

·Exterior wall panels are placed on lower panels to enclose the second level.

Formwork is placed around the column-to-beam steel connections of level 1, and cast-in-place concrete is placed around the steel connection. Cast-in-place concrete is also placed in the gap between the end face of hollow-core planks and the beam. Additional cast-in-place concrete is utilized to complete the panel-to-panel structural joint.

Construction continues in this manner until the beams for the roof are ready to be placed. At roof level beams rest on the top of the columns and do not frame into the side of them. Reinforcement from the beam is tied into reinforcement from the column. Cast-in-place concrete requiring formwork completes the connection.

A lightweight roof deck is placed to enclose the structure completely.

Incorporation of HVAC, plumbing, and electrical systems:

The PD2 Frame system utilizes notched primary beams to accommodate the horizontal services and minimize the total depth of the floor system. Notches 350 mm (14 in.) long and 100 mm (4 in.) deep are formed in the primary beams at the column-to-beam connection (Figure 3.18). This method allows services to be assembled in large sections on the floor below and lifted into position on hangers attached to the beam above. For vertical services, holes up to 0.9 m (3 ft) wide can be formed in 1.2 m (4 ft) wide floor units, and up to 0.6 m (2 ft) wide in 0.9 m (3 ft) wide floor units, depending on their position and the loading. Additionally, a limited number of 150 mm (6 in.) diameter holes may be cast in the flange area of floor units [Bison Concrete 1970].

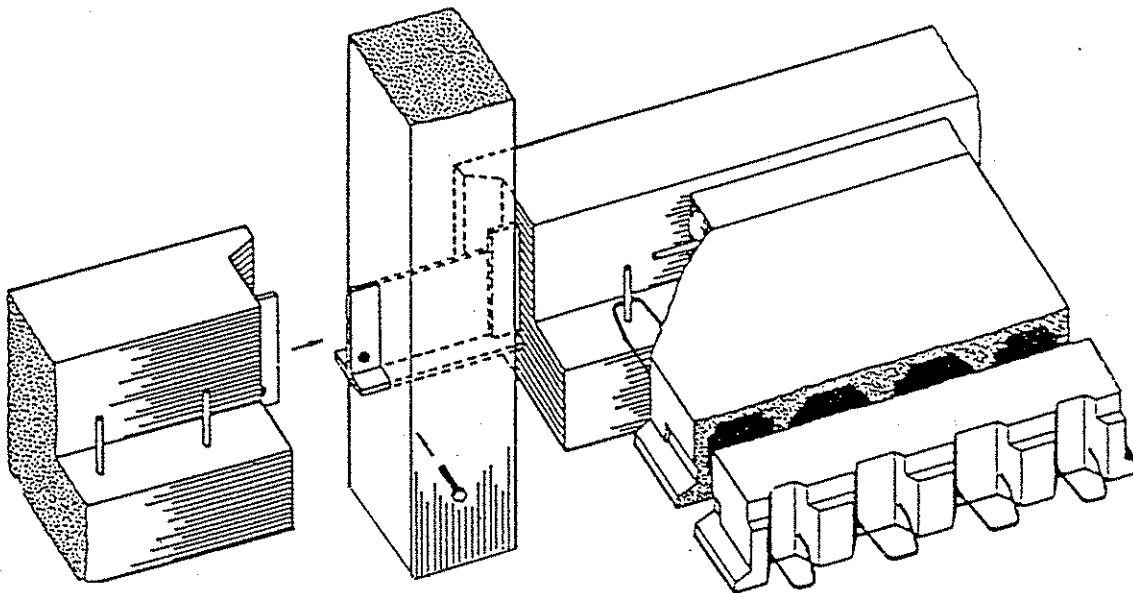

Figure 3.17. Column-to-edge beam connection detail. The steel plate from the column is bolted to the steel beam plate for stability during erection [adapted from Bison Concrete 1970].

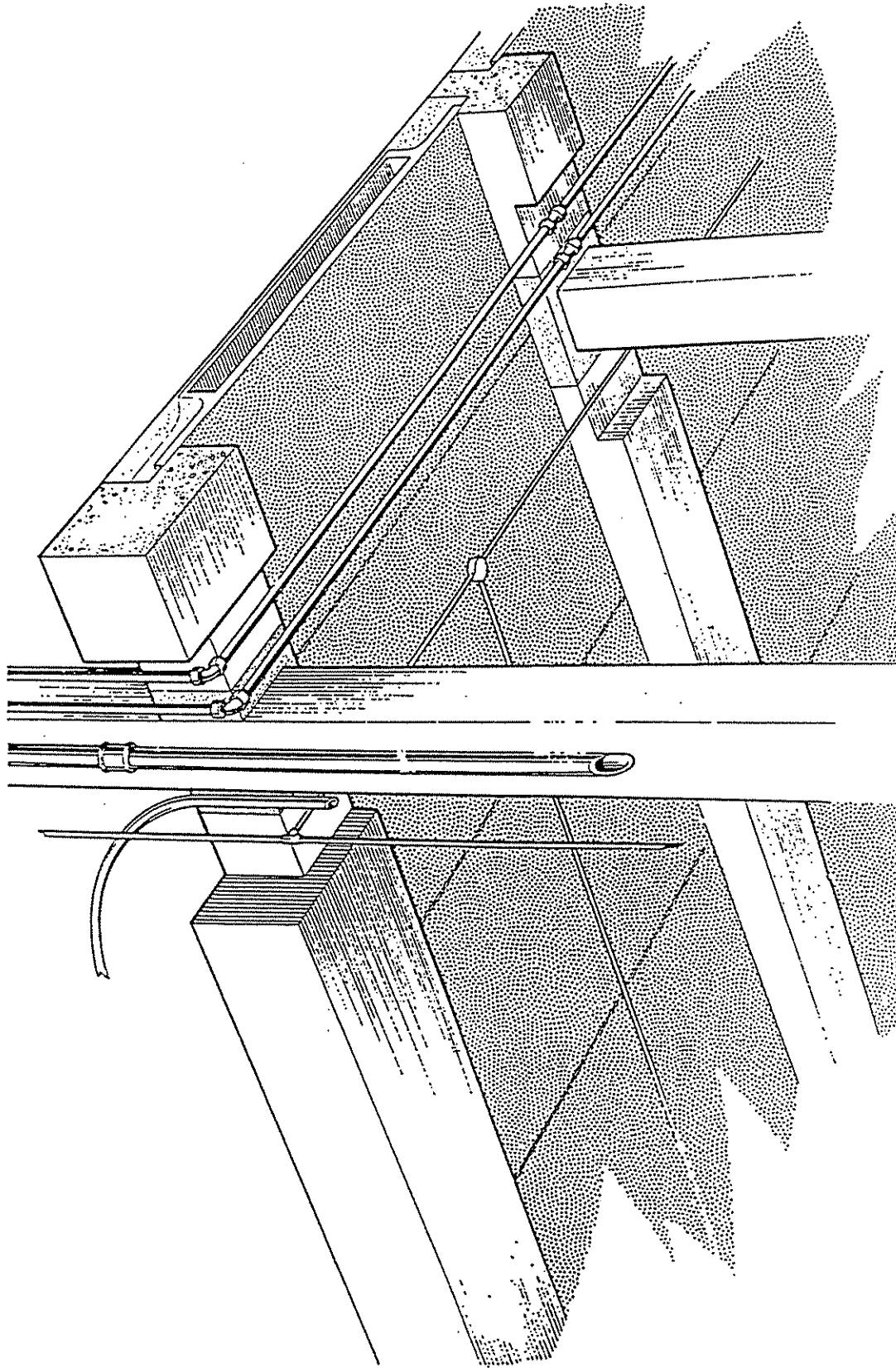

Figure 3.18. Accommodation of services. Notches are formed in primary beams at the column-to-beam connection to allow services to pass without increasing total floor depth [adapted from Bison Concrete 1970].

3.2.8 Prestressed Joist System

Developer: Prestressed Systems Industries
P.O. Box 524237
Miami, FL 33152
United States

Overview:

This structural floor system incorporates precast, prestressed joists, with cast-in-place concrete to provide a composite joist-slab system. The prestressed Keystone joists act as tensile components, and the cast-in-place slab furnishes the compressive component and monolithic connections. Prestressed Systems Industries (PSI) indicates that the ability of the structural floor system to achieve long spans with a relatively light weight makes the system popular in multi-story commercial structures.

The system is widely used in hospitals, parking garages, department stores, and highrise office buildings [Prestressed Systems Industries]. PSI began producing precast components for this system in 1965. The company indicated that in the last ten years they had produced and erected over 56 million square feet of occupied space with the system. Cast-Crete of Tampa also manufactures components for the system, and markets it as the Prestressed Tensile System.

Precast components:

Beams The precast portion of the composite soffit beam is cast in two standard cross sections: 610 mm wide x 165 mm deep (24 x 6.5 in.) or 406 mm wide x 241 mm deep (16 x 9.5 in.). Soffit beams are prestressed with 1724 or 1861 MPa (250 or 270 ksi) uncoated, seven-wire, stress relieved strands, are furnished with reinforcing steel and stirrups [Prestressed Systems Industries]. The 28 day compressive strength of the concrete is 41.37 MPa (6000 psi).

Joists Keystone joists are manufactured in four standard depths: 200, 300, 400, and 610 mm (8, 12, 16, and 24 in.). Spans range from 5 m to 25.5 m (16.4 ft to 83 ft) [Prestressed Systems Industries]. Joists are cast with small holes, so steel pins can be slipped through to support formwork for the cast-in-place slab. Joists are prestressed with 1724 MPa or 1861 MPa (250 or 270 ksi) uncoated, seven-wire, stress relieved strands, and the 28 day compressive strength of the concrete is 41.37 MPa (6000 psi).

Structural description:

The structural floor system can be thought of as a two component system. Precast, prestressed floor joists serve as tensile components and the cast-in-place floor slab serves as the compressive component. An additional component of the structural floor system is the soffit beam which is designed as a shored composite member. Negative moment reinforcing is tied to shear reinforcement from the joists and soffit beams to resist bending and provide continuity.

Design tables are provided by the manufacturer for preliminary joist selection and spacing. These tables are available for a cast-in-place slab with a thickness of 76 mm (3 inches) or more. For office loading, a span of 9.1 m (30 ft) would require a 400 mm (16 in.) joist with a 76 mm

(3 in.) cast-in-place topping. The joists would be spaced 2 m (6.5 ft) on-center. This floor system has the capacity to carry a superimposed live load of approximately 6 kN/m² (125 psf) [Cast-Crete Tampa].

Construction sequence:

- Formwork for single story columns is constructed, and concrete for the cast-in-place columns is placed.

- Precast soffit beams are placed between columns on temporary shoring.

- Slotted soffit beam "sideforms" are attached as shown in Figure 3.19. The slots will enable the joist to rest on the precast soffit beam. Typical formwork is 19 mm (3/4 in.) plywood. Additional formwork is built up around the column-to-beam connection.

- Joists are lowered and placed into the slots in the beam form. Joists may rest directly on the precast soffit beam or on the formwork if a deep beam is desired (Figure 3.19). Three joists may be lifted at once to reduce erection time.

- Steel pins are installed in joists. Steel angles are attached to the pins to support slab formwork (Figure 3.20). This hardware may be installed before the joist is set to speed erection.

- Purlins and plywood decking are placed on these angles, and serve as the formwork for the cast-in-place concrete slab (Figure 3.20). Blockouts are positioned on the formwork to facilitate vertical passage of HVAC, plumbing, and electrical services.

- Reinforcing steel is placed longitudinally on the soffit beam and additional two-way reinforcement is placed on the formwork for the slab.

- Concrete is placed. Formwork can be removed when the concrete has reached sixty-five percent (65%) of the design strength [Cast-Crete Tampa]. Beam shoring is not removed until erection is complete.

Incorporation of HVAC, plumbing, and electrical systems:

HVAC, plumbing, and electrical systems are suspended beneath the concrete floor system and fastened with standard hardware. Electrical conduit and junction boxes can be placed in the cast-in-place floor slab, with cables being pulled through the conduit after the concrete is placed. Blockouts are provided in the floor slab to allow for the passage of vertical plumbing and ducts.

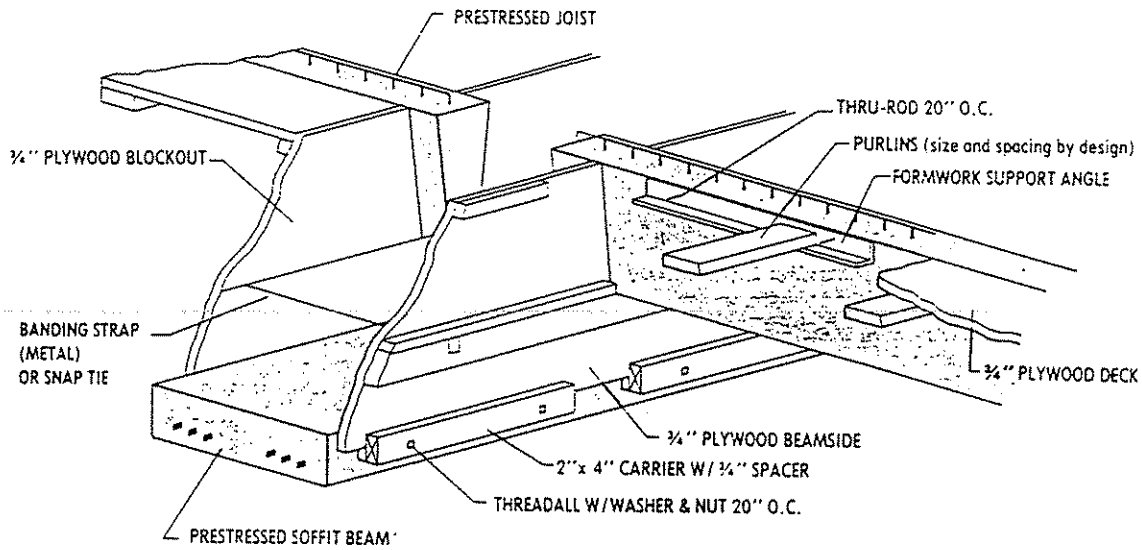

Figure 3.19. Soffit beam assembly for deep beams [adapted from Prestressed Systems Industries].

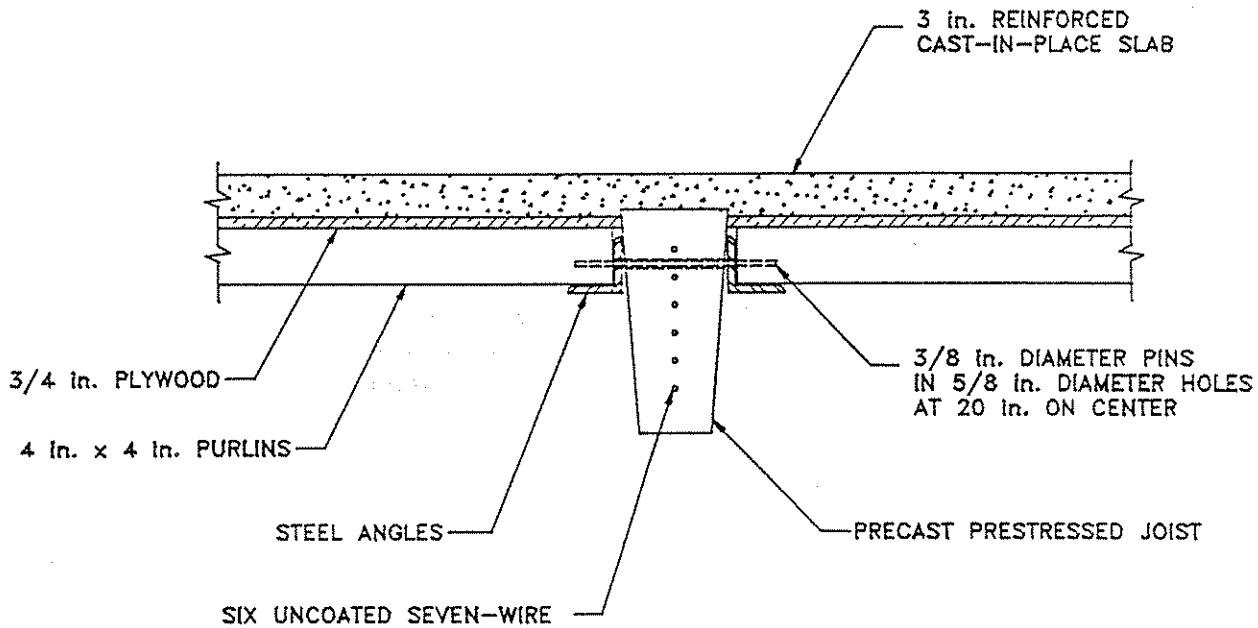

Figure 3.20. Section of precast Keystone joist during erection.

3.2.9 Quickfloor System

Developer: Quickfloor America, Inc.
W. T. McCalla, P.E. (U.S. and Canadian Representative)
6600 75 1/2 Avenue North
Brooklyn Park, MN 55428
United States

Overview:

The philosophy of the Quickfloor system is to create a shallow precast floor depth, and to utilize beam and floor components which can be mass produced. The precast beam component of the system is similar in section to a hollow-core plank, except that the top flange is not cast with the rest of the component. A typical beam section is shown in Figure 3.21b. The developer claims the system is economical because the components can be mass-produced using machinery similar to that used for the production of hollow-core planks. Beams are cast by a slipform or extrusion process [Quickfloor America 1990]. The system uses cast-in-place concrete for a floor topping and for composite beams.

The system was developed five years ago in Australia, where it has been used for various types of buildings. Quickfloor America, Inc. [1990] indicates that the system could be used for parking garages, shopping centers, office buildings, and light industrial buildings. The Quickfloor system has not been used in the United States.

Precast components:

Beams Prestressed beams can be produced on either a 1.2 m (4 ft) or a 2.4 m (8 ft) casting bed. If production is made on a 2.4 m (8 ft) bed, then two 1.2 m (4 ft) beam units can be produced simultaneously. A precast floor unit rests on the outer ledge of the beam as shown in Figure 3.21a. A variation to this design is shown in Figure 3.21b, where the 300 x 1880 mm (11.8 x 74 in.) beam section supports the floor unit on its top surface. For additional strength, post-tensioning ducts can be placed within the cavities of the precast beam [Quickfloor America 1990].

Currently the system cannot be produced with Dycore extrusion machinery because of the difficulties involved with incorporating top reinforcement in the beam unit. Dynamold has designed a machine to cast these beam components, and the system can be cast with the Roth machine of Germany [Quickfloor America 1990].

Floor Units Quickfloor floor units are similar to prestressed hollow-core units of the United States. As shown in Figure 3.21a, the typical Quickfloor 400 floor plank has a section of 420 x 1200 mm (16.5 x 47.2 in.) with three cores for structural efficiency [Quickfloor America 1990].

Structural description:

Partially precast beams, which serve as stay-in-place forms are combined with cast-in-place concrete to produce a rigid monolithic frame. Precast floor planks bear on the precast portion of the soffit beam. Negative moment steel is tied to shear reinforcement of the soffit

beam and the whole area receives a steel mesh mat for continuity. Cast-in-place concrete is placed as one operation in an effort to tie the whole floor system together. Beam components bear on column corbels and transfer load to the single story columns, which are either precast or cast-in-place. The system can span up to 10 m (33 ft) in the beam as well as in the floor direction under a superimposed live load of 3.5 kPa (70 psf). The depth of the floor system would be 585 mm (23 in.). If the beam span is reduced to 8.8 m (29 ft), the live load can be increased to 7.0 kPa (140 psf) with the same floor depth. The above span/depth figures are for an end bay. Internal bays will be able to accommodate longer spans.

Construction sequence:

- Formwork for cast-in-place columns is constructed and braced. If precast columns are used, then the column would be stabilized with anchor bolts. The formwork or precast column is then aligned vertically.

- For a cast-in-place column, the concrete is placed at this time. A column corbel is then placed on the column. This corbel is the width of the beam component.

- Temporary beam shoring is erected. The precast Quickfloor beam is then placed on the shoring. The end portion of the beam will rest on the corbel.

- Precast Quickfloor floor units are placed on the precast beams. If planks are placed on only one side of the beam, the beam must be shored to resist rotation.

- Electrical conduit is placed on the precast beams between the ends of the planks and cores of the planks which will not be utilized for services are blocked to prevent cast-in-place concrete from filling the cores.

- Negative moment steel is placed over the precast beam, and a steel mesh mat is spread across the entire floor area.

- Concrete is then poured for the composite beam and for a floor topping, producing a level floor surface.

- Shoring can be removed once the composite cast-in-place concrete reaches the required design strength, but would remain in place if construction on the next floor were to begin immediately.

Incorporation of HVAC, plumbing, and electrical systems:

Electrical systems can be placed in the cast-in-place portion of the floor system and/or within the cores of the hollow-core floor planks. Typically, plumbing and ductwork are suspended beneath the precast floor system and anchored with standard hardware.

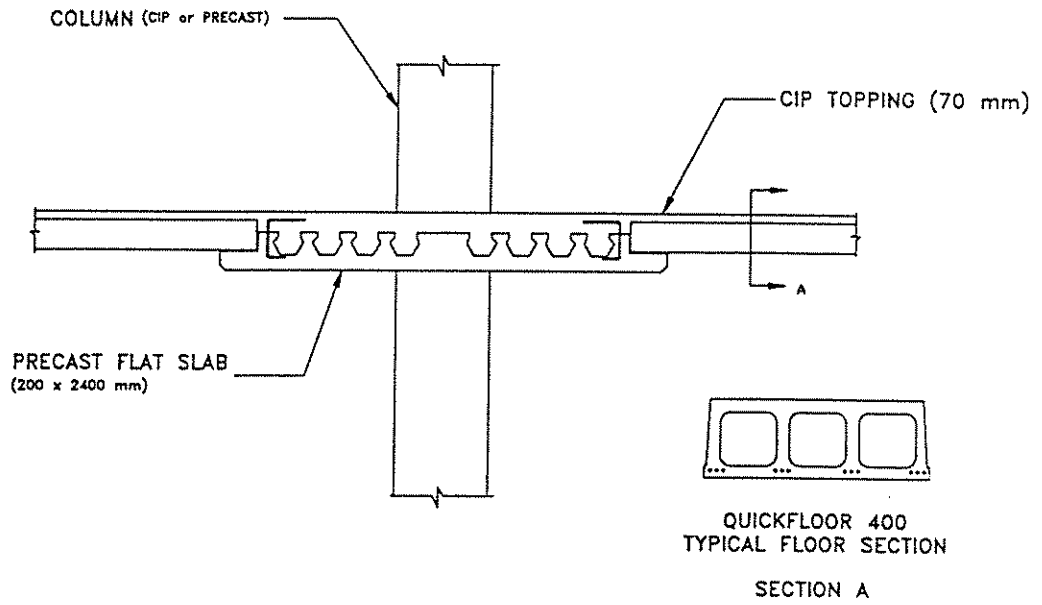

(a)

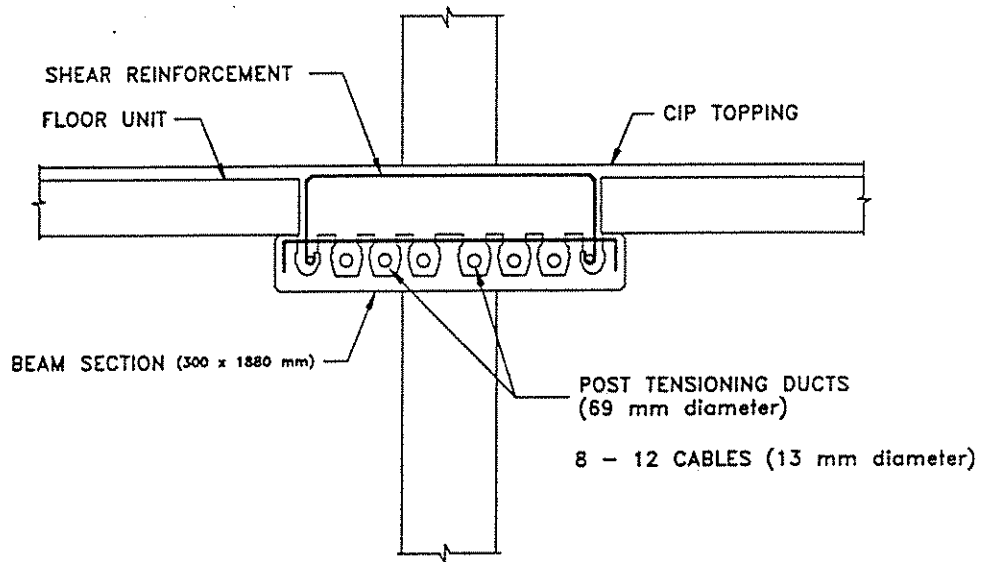

(b)

Figure 3.21. Typical beam cross-sections: a) Precast flat slab (200 x 2400 mm) for short beam spans; b) Post-tensioned beam section (300 x 1880 mm) for medium to long spans.

3.2.10 Structurapid System

Developer: Brevetti Gaburri
Alassio (Savona)
Italy

Overview:

The Structurapid system utilizes prefabricated concrete columns and beams, which fit together by means of tongue and groove fittings. The structural system is designed for multi-story buildings with medium to light loading. The system can be used for heavy loadings, but member size, and material properties need to be changed. A reported major advantage of the system is the simple beam-to-column connection. The combination of precast concrete and simplified connections enables a crew of five to erect the framework for a 451 m² (4,850 sq. ft) floor area in a single day [Diamant 1965].

The system was first used in Italy in the early 1960's and since has been used for residential and commercial buildings.

Precast components:

Columns The columns are precast hollow tubes with a wall thickness of 50 mm (2 in.). They are reinforced by vertical steel rods and spiral wire reinforcement. Columns are cast with rectangular slots at the column end to allow beams to be dropped in place (Figure 3.22). Three types of columns are commonly used [Diamant 1965]:

- Square columns with a 230 mm (9 in.) cross-section, reinforced with four vertical rods. These columns can support approximately 267 kN (60 kips) for a free length of 4.27 m (14 ft).
- Square columns with a 305 mm (12 in.) cross-section, reinforced with four vertical rods. These columns can support approximately 516 kN (116 kips) for a free length of 4.27 m (14 ft).
- Tubular columns with an external diameter of 305 mm (12 in.), reinforced with eight vertical rods. These columns can support approximately 500 kN (112 kips) for a length of 4.27 m (14 ft).

Beams As shown in Figure 3.22, the beams are T shaped with a 83 mm (3.25 in.) wide web. The depth of the units are either 254 mm or 356 mm (10 or 14 in.) and the width of the top flange is either 200, 305, or 355 mm (8, 12, or 14 in.). Shear reinforcement, 150 mm (6 in.) in length, protrudes from the top of the beam to achieve continuity with floor units. Beam ends are specially reinforced and the top flange is eliminated to allow the beam to slip onto the column [Diamant 1965].

Floor units Floor units consist of hollow-core slabs which rest on the beam flange.

Structural description:

Precast concrete columns and beams are connected by means of a "tongue and groove" system of joining. The tee beam is slipped into slots in the column and locked by the natural geometry of the connection. Reinforcing is placed on the precast tee beam, and bent down into the hollow column core. With the placement of cast-in-place concrete in the column cavity, a monolithic beam-to-column and column-to-column joint is developed. Additional cast-in-place concrete is used as a structural floor topping to ensure a rigid floor diaphragm.

The structural system is suitable for low-rise (1 to 5 stories) structures, which will be subject to medium or light loading. A typical bay size is 4.57 m x 4.57 m (15 ft x 15 ft). Larger bay sizes and heavier loadings can easily be accommodated if prestressed tee beams are used instead of conventionally reinforced concrete beams. Span/load data was not available for the system.

Construction sequence:

·The foundation is placed with prefabricated steel reinforcement cages protruding 76 mm (2.5 ft) upward at column locations.

·The columns are lowered over the steel cages (Figure 3.22). The column is positioned vertically by adjustable struts. Once the column is in position, concrete is poured in the column up to a maximum height that will not interfere with the placement of the reinforcing cages for the beam-to-column connection.

·Beams are dropped into the column slots. The geometry of the beam end enables it to lock into the edge of the concrete column.

·Floor planks are placed and shear keys between planks are grouted.

·Prefabricated steel reinforcement cages 1.52 m (5 ft) in length are lowered into the top of the column. The cage protrudes upward from the column 762 mm (2.5 ft). Additional reinforcement is placed on the precast tee beam and tied into the column reinforcement cage. The column for the next level is slipped over the reinforcement cage and leveled.

·Cast-in-place concrete is placed in the remainder of the column cavity and the beam-to-column connection. Additional concrete is placed on the precast tee beam and leveled with the top of the floor planks.

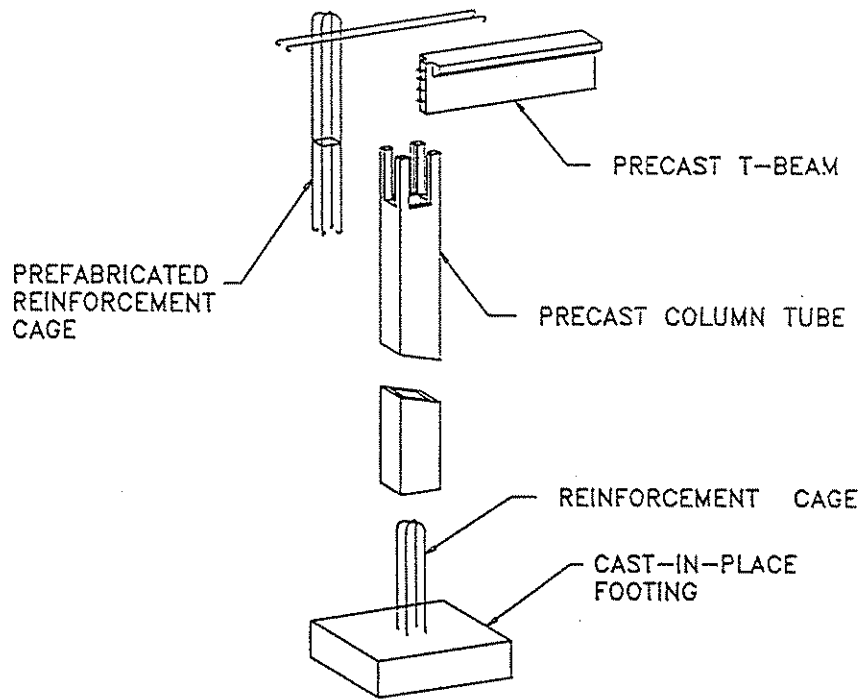

Figure 3.22. Footing-to-column and beam-to-column connection. Tongue of tee beam is dropped into slot of precast column.

3.2.11 Swedish System

Developer: AB Strangbetong
Lindhagensgatan 132
Box 30036
104 25 Stockholm
Sweden

Overview:

The conventional system used in Sweden for multi-story commercial construction is comprised of precast multi-story columns, precast inverted tee beams or rectangular beams, and precast hollow-core planks or double tees. While the components of the system are similar to the U.S. Conventional system, the system takes advantage of modular coordination and a high degree of integration of the piping and duct systems. Similar to the Duotek system, the beam components are cast with rectangular openings to allow services to pass.

The present system used in Sweden is the result of continuous development over four decades. The system is typically used only in structures of less than twenty stories. Office, schools, hospitals, department stores, and multi-story residential buildings are frequently constructed using this system [Rise].

Precast components:

Columns A set of standard rectangular cross section, non-prestressed columns, are used.

Beams Either rectangular or inverted tee shaped beams are used. The rectangular beams are available in standardized cross sections. Beam depth increases from 300 mm to 800 mm (11.8 to 31.5 in.) in 100 mm (3.9 in.) increments, and beam width increases from 200 mm to 800 mm (7.8 to 31.5 in.) with the same increment [Rise].

Floor units Precast floor units are mostly 1200 mm (47 in.) wide, and 265 or 380 mm (10 or 15 in.) deep pretensioned extruded hollow-core units, with the latter spanning a maximum of 18 m (59 ft). In cases with heavy loading, 2400 mm (94.5 in.) wide double tee sections of various standard depths are used [Rise].

Structural description:

The components of the system, with standardized cross-sections and connectors, but variable lengths, produce a simple structure. The typical layout of the system involves hollow-core floor units spanning one way from facade-to-facade often supported by an intermediate column and beam frame.

The standard connections are designed to meet both structural and other functional requirements. The beam-to-column connection can consist of a column corbel, or if a hidden support is desired, the connection can be made with a steel plate.

Stability is provided by load bearing facade walls and / or elevator shafts, stairs, etc. The wall panels are connected to achieve diaphragm action. The floors can transfer horizontal forces

to the stabilizing units by diaphragm action. Since the hollow-core planks are not given a reinforced concrete topping, the grouted joints between the planks must transfer the horizontal and vertical shear forces. Additional design information was not obtained.

Construction sequence:

Details of the construction sequence were not obtained.

Incorporation of HVAC, plumbing, and electrical systems:

This system uses a high degree of integration of plumbing and ducts into the structural floor system. For example, each core in the hollow-core floor units is given a specific service function. In this way, a systematic placement of services is achieved through the entire building. This method can only be utilized if floor planks bear on the top surface of the precast rectangular beam members. Rectangular beam openings are often provided to accommodate other services.

Heating and ventilation systems are integrated into the precast frame, and make use of the heat mass of the concrete floors through which the supply ventilation air is circulated before entering the room. The effects of using heat mass of the floors in this way are different during summer and winter conditions. If the climate is hot, a partial air conditioning system is achieved by cooling the floors with the cooler night air. If the climate is cold, possible surplus energy produced from activity in the building is stored more effectively in the floors.

3.2.12 Thomas System

Developer: Thomas Concrete Products
Oklahoma City, Oklahoma 73129
United States

Overview:

The Thomas system is comprised of multi-story precast columns, composite shell beams, and precast double tee floor units. The unique structural component of the system is the U shaped shell beam. Cast-in-place concrete is placed within the beam producing a composite member. As shown in Figure 3.23, the beam flanges serve as supports for tee stems and the beam is supported by precast column corbels [Thomas Concrete Products 1985].

Thomas Concrete Products stopped producing precast structural products in the mid 1980's. This system has been used in the mid-west for multi-story office building construction.

Precast components:

Columns Multi-story columns with corbels are used for the system. The column is cast with a steel base plate to allow the column to be anchored to the foundation. Columns are cast with four couplers at the beam level. Dywidag bars from the beam are threaded into the couplers during erection. The concrete has a 28 day compressive strength of 41 MPa (6000 psi) [Thomas Concrete Products 1985].

Beams Pretensioned single span U shaped or shell beams serve as forms for cast-in-place concrete as shown in Figure 3.23. Concrete with a 28 day compressive strength of 41 MPa (6000 psi) is used for the precast portion of the beam, and a strength of 34.5 MPa (5000 psi) is required for cast-in-place concrete [Thomas Concrete Products 1985].

Floor Units Light-weight precast double tees serve as floor units. Typical double tees are 2.44 m (8 ft.) wide and 610 mm (24 in.) deep. The unit weight of the concrete is 1924 kg/m³ (120 pcf) and the members are prestressed with 13 mm (1/2 in.) diameter strands [Thomas Concrete Products 1985].

Structural description:

For 5 kN/m² (100 psf) of live load and spans of 9.1 m (30 ft.) a shell beam approximately 915 mm (36 in.) deep is required. With a 76 mm (3 in.) topping, the structural depth of the floor system is approximately 990 mm (39 in.) deep. Additional structural design information was unavailable.

Construction sequence:

- Anchor bolts are set to a tolerance of 3 mm (1/8 in.) horizontal and vertical. If the ground floor slab is to be poured before the precast columns are erected, a 0.6 m (2 ft) blockout must be provided at column locations.
- Columns are slipped over the anchor bolts. The columns are aligned vertically with the aid of shims. Anchor bolts are tightened and dry-pack grout is placed between the base plate and the foundation. The column-to-foundation connections are designed for erection conditions to eliminate the need for additional column bracing.
- Before lifting the shell beams into position, four Dywidag bars are placed in the precast shell beam. The shell beam is then set on the column corbels.
- Floor units are erected on each side of the beam. Connections between flanges of adjacent floor units are welded. If beams are loaded on only one side, shoring is required to prevent rolling and torsion. Shoring is left in place until connections are complete.
- Locknuts are installed on the end of the Dywidag bars and threaded in the steel column couplers. Locknuts are tightened against the column.
- Cast-in-place concrete is placed in the beam to a level flush with the top of the beam, and the end of the beam is dry-packed with non-shrink grout.
- Any required vertical openings in double tee floor units are cut.
- Reinforcing steel or mesh is placed on the precast floor deck. A 76 mm (3 in.) cast-in-place topping is poured.

Incorporation of HVAC, plumbing, and electrical systems:

Services are positioned beneath the precast floor and suspended with standard hardware.

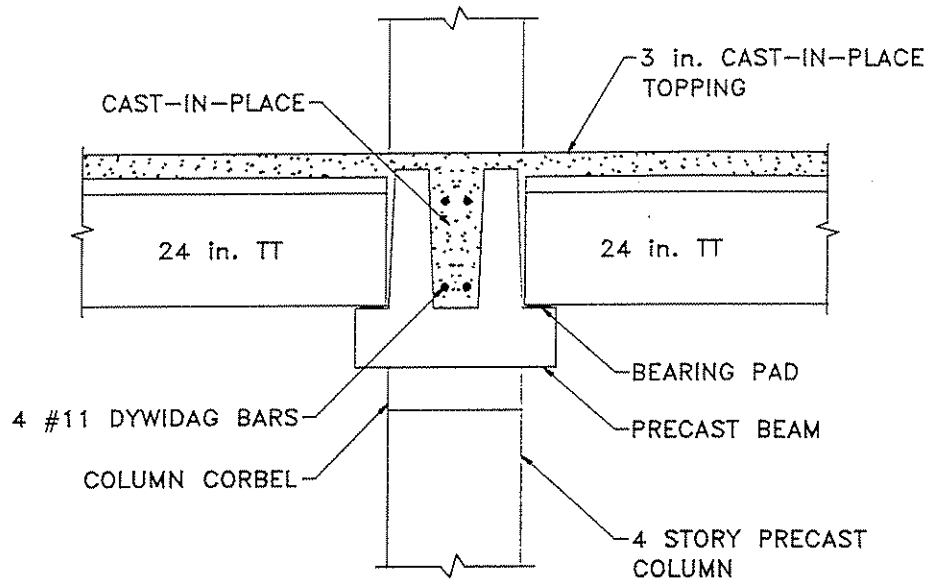

Figure 3.23. U shaped shell beam.

3.2.13 Trilposite System

Developer: Portland Cement Association
5420 Old Orchard Road
Skokie, Illinois 60076-1083
United States

Overview:

Trilposite is a precast building system composed of three major components: 1) structure, 2) HVAC, and 3) partitions, hence the name. The system uses precast columns, shear walls, and supporting floor units, in conjunction with cast-in-place beams and floor slabs. Floor units are similar in configuration to inverted double tees, with tee stems protruding upward. Provided within the structural depth of the precast system is a plenum for HVAC ducts. Electrical and plumbing services can also be housed in this plenum (Figure 3.25). The precast spanning members provide a working platform for the service trades and overhead work is eliminated. Literature from the Portland Cement Association (PCA) indicates that floor members can span up to 10.7 m (35 ft) with a 457 mm (18 in.) depth [PCA 1969].

PCA, in cooperation with the architectural firm of Hellmuth, Obata and Kassabaum of St. Louis, Missouri, developed the Trilposite structural system to help meet the demand for new dormitory and academic buildings. The Trilposite system was selected in 1969 by the University of California as the structural system for its University Residential Building System program (URBS) [PCA 1969]. It is not known if Trilposite is presently used in the precast construction industry.

Precast components:

Columns Multi-story columns are cast up to four stories in length. These conventionally reinforced columns are cast with notches at the beam level to facilitate the cast-in-place beam-to-column connection. Horizontal holes are also cast into the column at the beam level to allow reinforcing bars to be threaded through and provide continuity between beams.

Floor units Pretensioned floor units are similar in configuration to inverted double tees. The stems of the tees are cast with 200 x 250 mm (8 x 10 in.) oval perforations [PCA 1969], which allow services to run transversely. The flange of the precast double tee serves as the tensile component of the floor system.

Structural description:

The Trilposite system utilizes both precast columns and inverted double tee floor units as structural members. Cast-in-place concrete is used for the topping slab of the inverted double tees. The cast-in-place floor slab acts as the compression member of the system and as a horizontal diaphragm. Typical thickness of this floor slab is 63.5 mm (2.5 in.) as shown in Figure 3.24. Interior and exterior beams are also cast-in-place and are cast with 200 x 250 mm (8 x 10 in.) oval penetrations to allow for the horizontal distribution of services through the floor

system. Beam spans are made continuous by threading longitudinal beam reinforcement through the column and joining it with adjacent beam reinforcement. Connections are cast-in-place and produce a monolithic frame.

Double tee floor members are 394 mm (15.4 in.) deep and range in span from 4 m (13.3 ft) to 10.7 m (35 ft) in 508 mm (20 in.) modules. In the transverse direction, beams span from 2.54 m (8.3 ft) to 6.10 m (20 ft), also in 508 mm (20 in.) modules [PCA 1969]. The structural depth of the floor system is 457 mm (18 in.). Included in this depth is the 63.5 mm (2.5 in.) deep cast-in-place concrete floor topping (Figure 3.24).

Construction sequence:

- Precast concrete columns are erected on the floor below or the foundation. Depending on story height, either one, two, or three story columns can be used. Columns are braced.

- Shoring is erected between columns. Formwork for cast-in-place beams is erected on the shoring.

- Precast concrete inverted tees with preformed perforations in the tee stems are erected on the temporary end shoring. Spans in excess of 7.6 m (25 ft) require intermediate shoring.

- On the working platform provided by the inverted tees, the HVAC ducts can be placed. Electrical distribution lines and plumbing conduit is also placed on the precast member.

- Precast shear walls are erected within the structural frame. Reinforcement extending from the precast walls overlaps the interior and exterior beam reinforcement, which is placed at this time.

- Permanent formwork is placed between the stems of double tees to support the cast-in-place concrete floor slab.

- Reinforcing bars for the floor slab are placed on the formwork. The reinforcement is tied into beam reinforcement. A steel mesh is also placed on the formwork to control cracking.

- Final forming of the interior and exterior cast-in-place beams is completed.

- Services are installed, then concrete is placed for the topping slab, and for interior and exterior beams. Temporary shoring for the beams are removed after the concrete has reached the required strength.

Incorporation of HVAC, plumbing, and electrical systems:

The system provides within the structural depth of 457 mm (18 in.) a cross section of 356 mm x 914 mm (14 in. x 36 in.) as a plenum for heating, ventilating, air conditioning, electrical and plumbing services. The plenum is provided in the structural floor system using a precast member which is the bottom slab and vertical stems, in addition to a cast-in-place slab as the top plane. The plenum works as a return air space with the HVAC supply being positioned in it. The services in the plenum under the floor slab pass through the stems of the precast inverted tee members by means of a series of 203 mm x 254 mm (8 in. x 10 in.) holes (Figure 3.25).

Similar holes are field cast in the cast-in-place beams. According to PCA, provision can also be made for 203 mm x 406 mm (8 in. x 16 in.) rectangular ducts. Electrical services are run through the plenum using conduit and junction boxes. Accessibility to the HVAC, plumbing, and electrical services is provided by various size precast access panels which are located in the floor. The panels range in size from 305 mm x 915 mm (12 in. x 36 in.) to 915 mm (36 in.) square.

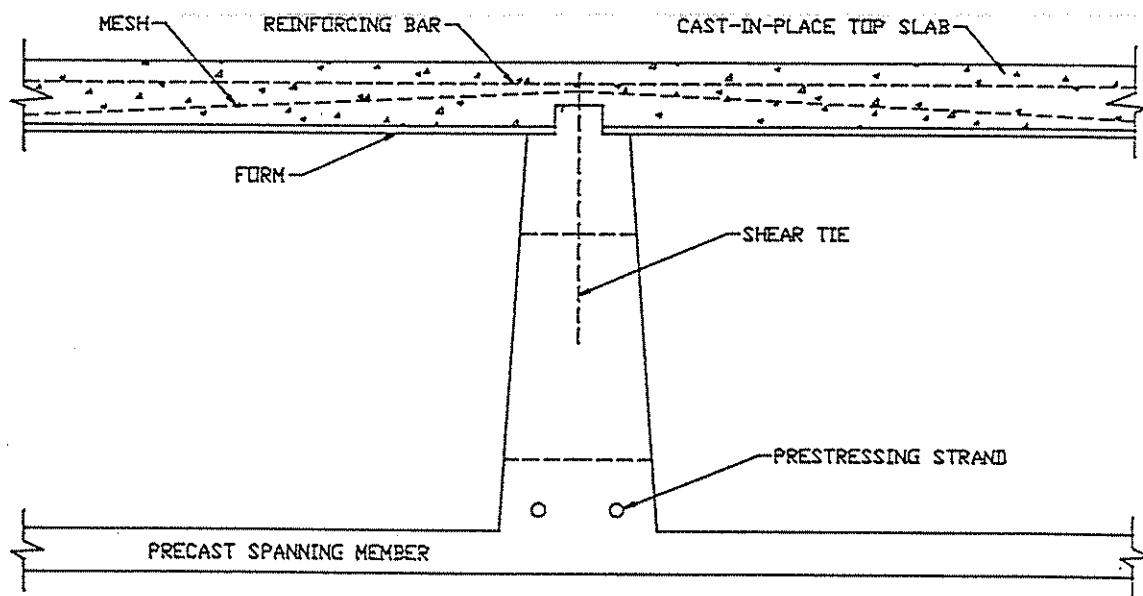

Figure 3.24. Section through Trilposite floor system.

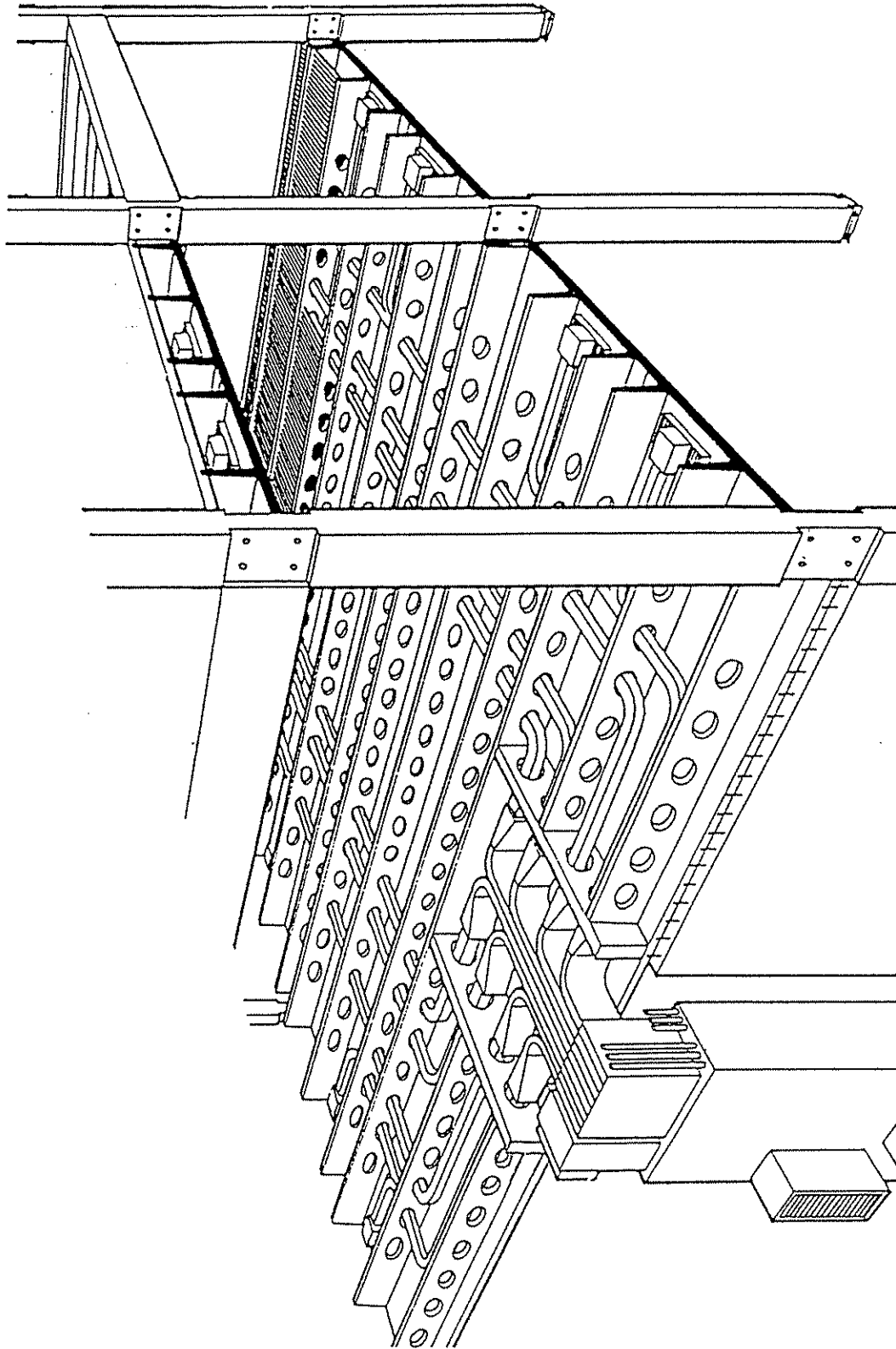

Figure 3.25. Incorporation of services. Provided within the structural depth of the floor system is a 356 mm x 914 mm (14 in. x 36 in.) plenum for services. Inverted double tees and cast-in-place beams are cast with 203 mm x 406 mm (8 in. x 10 in.) holes for services [adapted from PCA 1969].

3.3 EMERGING SYSTEMS

3.3.1 Contiframe System

Developer: Contiframe Structures Limited
Holly Lane Industrial Estate
Atherstone, Warwickshire CV9 2RN
Great Britain

Overview:

The concept behind the structural system is to avoid connections in highly stressed areas and to avoid costly fittings associated with the column-to-beam connections. The precast frame is analyzed as a cast-in-place frame, and the results are used to position beam-to-beam connections at areas of minimal stress. The system consists of single story precast columns, precast multi-span beams, precast "infill" beams, and precast, prestressed floor members (Figure 3.26). The beam-to-infill beam connection consists of steel angles which are cast into each member and bolted together during erection.

The patent on the Contiframe system is currently pending in Great Britain [Contiframe Structures 1992]. The system was originally developed for office or similar type structures, with spans of 6.0 to 7.2 meters (19.7 to 23.6 ft), but could be modified for larger spans and heavier loading with suitably increased beam and column sizes.

Precast components:

Columns Single story columns are precast with a standard cross section of 400 mm x 400 mm (15.75 in. x 15.75 in.). The columns are cast with four threaded rods protruding from the upper face. These rods slide through ducts which are precast in the beams and are coupled to rods protruding from the upper column. Columns are notched at both top and bottom to facilitate the connection. The geometry of the column and a detail of the column-to-column splice is shown in Figure 3.27.

Beams Internal beams can be single span or continuous over two spans. The beam is slipped over threaded steel rods which protrude from the column. The beam extends past the column to avoid a beam connection at a high stress zone. An infill beam as shown in Figure 3.26 is used to link multi-span beams. The beam-to-infill beam connection is located where the bending moment will be a minimum. Beams are tapered at each end to facilitate the connection. Steel angles are embedded in each beam to allow the two beams to be bolted together for continuity (Figure 3.27).

Floor units Hollow-core floor units produced by Contiframe Structures are to be used with the system. The company produces floor units with a depth of either 150 mm (6 in.), or 200 mm (8 in.). Load/span tables for these floor units are provided by Contiframe Structures.

Structural description:

The philosophy behind the system is to analyze the precast frame as a continuous monolithic structure, and use the results of this analysis to position the beam-to-beam connection in areas of minimal stress [Contiframe Structures 1992]. The standard frame consists of 550 mm (21.6 in.) deep by 400 mm (15.75 in.) wide beams on 400 mm (15.75 in.) square columns. The depth of the beams can be increased in steps of 50 mm (2 in.) where spans and loads require it. In low-rise structures, horizontal stability can be achieved by the frame alone. In mid-rise structures, stability can be provided by either precast or cast-in-place concrete walls, brick infill panels, or steel bracing. Additional design information was not obtained.

Construction sequence:

·Pockets are formed in the foundation to allow single story columns to be erected. Columns are leveled with shims and bracing and cast-in-place concrete is placed in the foundation pocket.

·Prefabricated beams are slipped over the threaded rods which protrude from the column.

·With the beam in position, the next level of columns are placed and the column-to-column connection is made. The threaded rods from the lower column are coupled to the rods from the upper column using a mechanical connector.

·Infill beams are placed between standard beams and the steel angle which is cast in each beam is aligned. The steel beam-to-beam connection is then made with two bolts.

·Beam-to-beam and beam-to-column joints are filled with grout.

·Hollow-core planks are placed. Shear keys between adjacent planks and the gap between the end of planks is grouted.

Incorporation of HVAC, plumbing, and electrical services:

Services are suspended beneath the precast floor members and anchored with standard hardware.

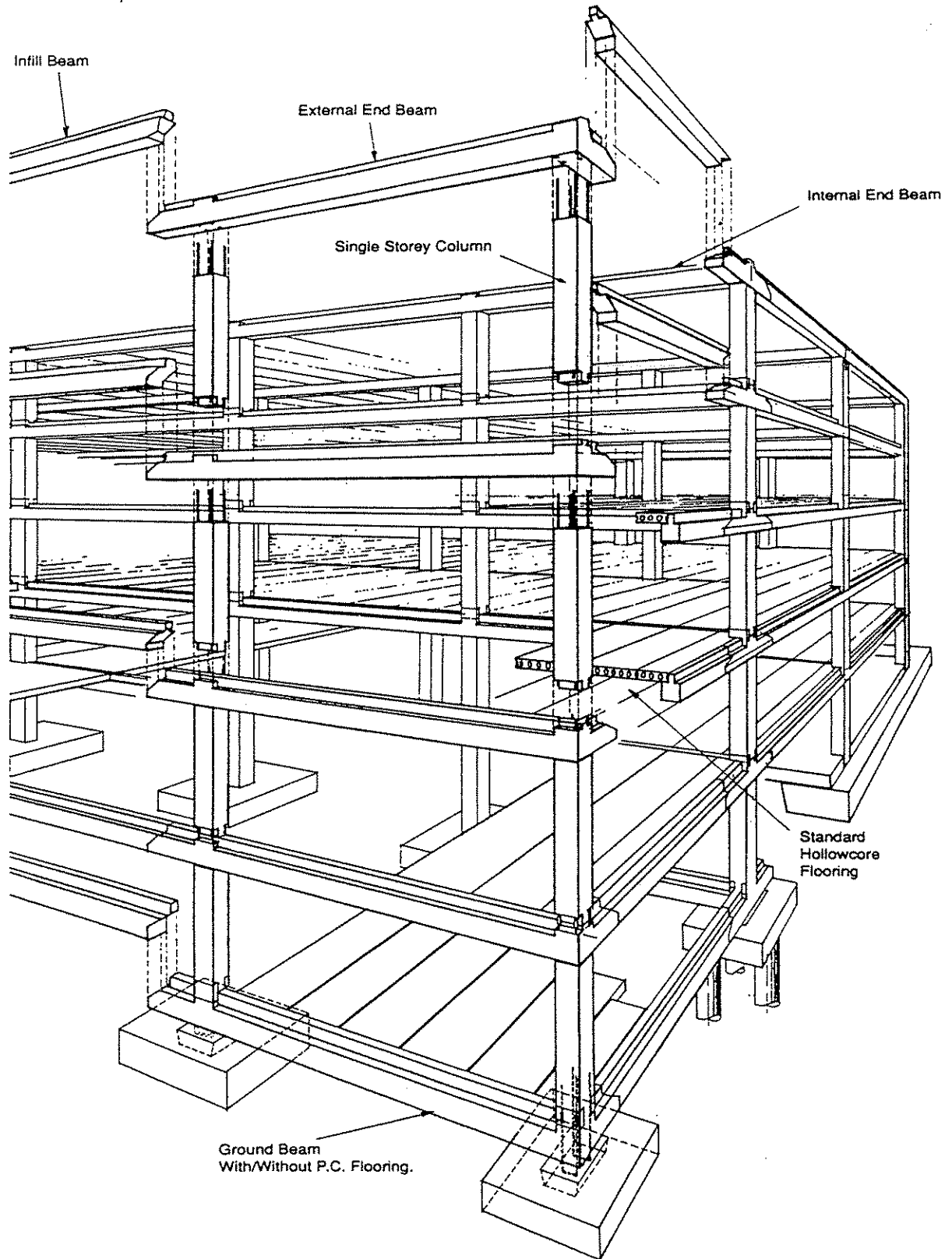

Figure 3.26. Precast structural components [adapted from Contiframe Structures 1992].

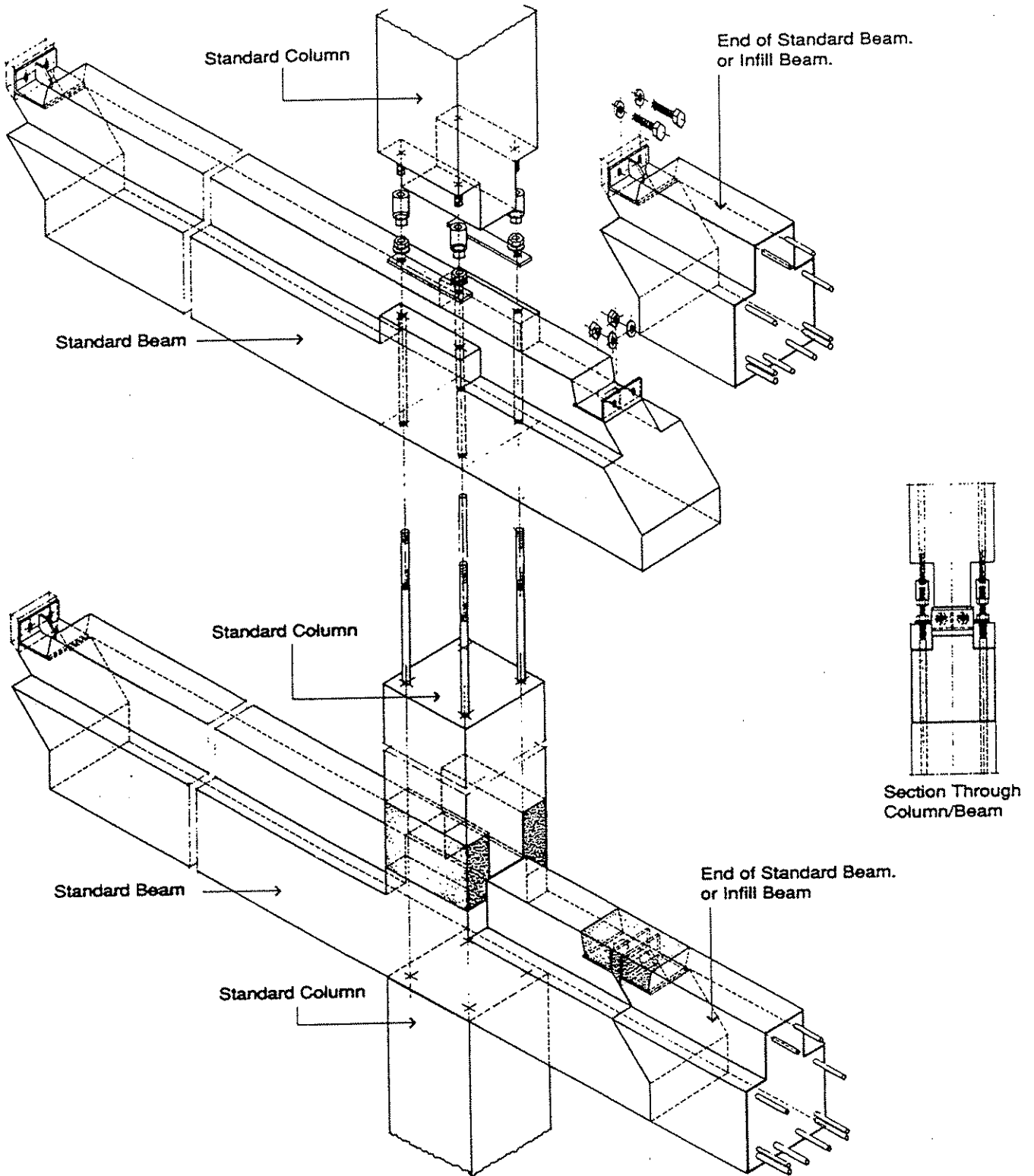

Figure 3.27. Beam-to-column connection and bolted beam-to-beam mechanical connection [adapted from Contiframe Structures 1992].

3.3.2 Spanlight System

Developer: Dow Mac Projects
Tallington Factory,
Tallington, Stamford,
Lincs,
PE9 4RL
Great Britain

Overview:

The Spanlight system is currently under development at the Polytechnic of Central London. The system consists of precast reinforced columns, pretensioned spine beams, reinforced edge beams, and pretensioned hollow-core floor units (Figure 3.28) [Dow Mac 1991]. The pretensioned spine beam, which is similar in geometry to a shallow inverted double tee, is the key precast element of the system. As shown in Figure 3.29, the beam acts as a stay-in-place form for cast-in-place concrete, and is post-tensioned to increase beam capacity and frame continuity. Features of the structural system include: a span-to-depth ratio of 18-to-20, the elimination of intermediate beam shoring, and the use of prestressing.

In 1991, a full scale test on a spine beam was terminated after the beam had sustained a load of 23.2 kPa (484 psf) [Construction News 1991]. Further research is underway to improve the behavior of the column-to-beam connection, and to reduce the mid-span deflection of the beam. Since spans of 9 m (30 ft) can be achieved with a relatively shallow floor system, Dow Mac expects the system to be competitive in the construction of multi-story commercial buildings [Dow Mac 1991].

Precast components:

Columns Multi-story precast columns are cast with four pre-formed holes at the floor level to allow for spine beam prestressing cables to pass through. The rectangular column is notched at floor level to facilitate the attachment of a steel collar, which will temporarily support the spine or edge beam [Dow Mac 1991].

Spine or edge beams The spine beam is geometrically similar to a shallow inverted double tee beam with a center trough which acts as a stay-in-place form for cast-in-place concrete (Figure 3.29). The beam is subject to two separate stages of prestressing. The precast portion of the beam is pretensioned upon casting in the plant, and the trough portion of the beam is filled with cast-in-place concrete, after cables have been placed in the trough and tensioned. Spine beams are manufactured in three standard depths; 325 mm, 410 mm, and 500 mm (13 in., 16 in., and 20 in.). The maximum beam length is 9.1 m (30 ft) and the standard width is 915 mm (36 in) [Dow Mac 1991].

Floor units The structural system is designed to utilize precast hollow-core planks as the floor unit. Manufactured by Costain Dow Mac, the planks are produced in three depths: 200 mm, 250 mm and 300 mm (7.88 in., 9.84 in., and 11.81 in.) [Dow Mac 1991]. The maximum length of the floor units is 9 m (30 ft).

Structural description:

This precast beam and column system employs prestressing and cast-in-place concrete in an effort to reduce the total depth of the floor system. Spine beams are post-tensioned so that the beams will act as continuous members rather than simply supported members. This prestressing produces a friction connection between the spine or edge beam and the column, enabling column corbels to be eliminated. Thus, the structural system has continuity with moments being transferred into the columns. The cast-in-place concrete serves as protection for the prestressing cables and provides the finished floor surface. Continuity between floor units and the beam is achieved by using cross tie bars which are placed over the beam and incorporated into the cast-in-place concrete.

Dow Mac indicates that for typical office loading, a span of 8.5 m (28 ft) would require a 800 mm (31.5 in) deep precast structural floor system. The depth of the beam would be approximately 500 mm (20 in.) and the depth of the precast floor plank would be 300 mm (12 in.) [Dow Mac 1991].

Construction sequence:

- Precast multi-story columns are erected on the foundation or the floor below, and a temporary steel collar is fitted around the column at the floor level. The collar will support the spine beam.
- Spine or edge beams are placed on the steel collars. No intermediate shoring is required.
- Hollow-core floor units are placed on each of the lower flanges of the spine beam. Stability of the spine beam must be maintained during the placement of the floor units.
- Prestressing cables are threaded along the trough of the beam and through the columns. The cables are depressed at mid-span to more effectively resist bending moments and are anchored to the columns with normal barrels and wedges. The cables are post-tensioned to create the effect of having one continuous beam rather than a series of simply supported beams.
- Mild reinforcing cross tie bars are installed along the flanges of the spine beam and tied into the floor units.
- Concrete with a strength of 35 MPa (5000 psi) is placed into the trough of the beam creating a direct bond with the prestressing cables. Concrete is also placed in the gap between the floor units and the beam, embedding the cross tie bars.
- The temporary steel brackets can be removed from the column, when cast-in-place concrete has reached a strength of 20 MPa (2800 psi).

Incorporation of HVAC, plumbing, and electrical systems:

The philosophy with this structural system is to create precast components which are as shallow as possible, so that the HVAC, plumbing, and electrical services can be suspended beneath the beam and floor units.

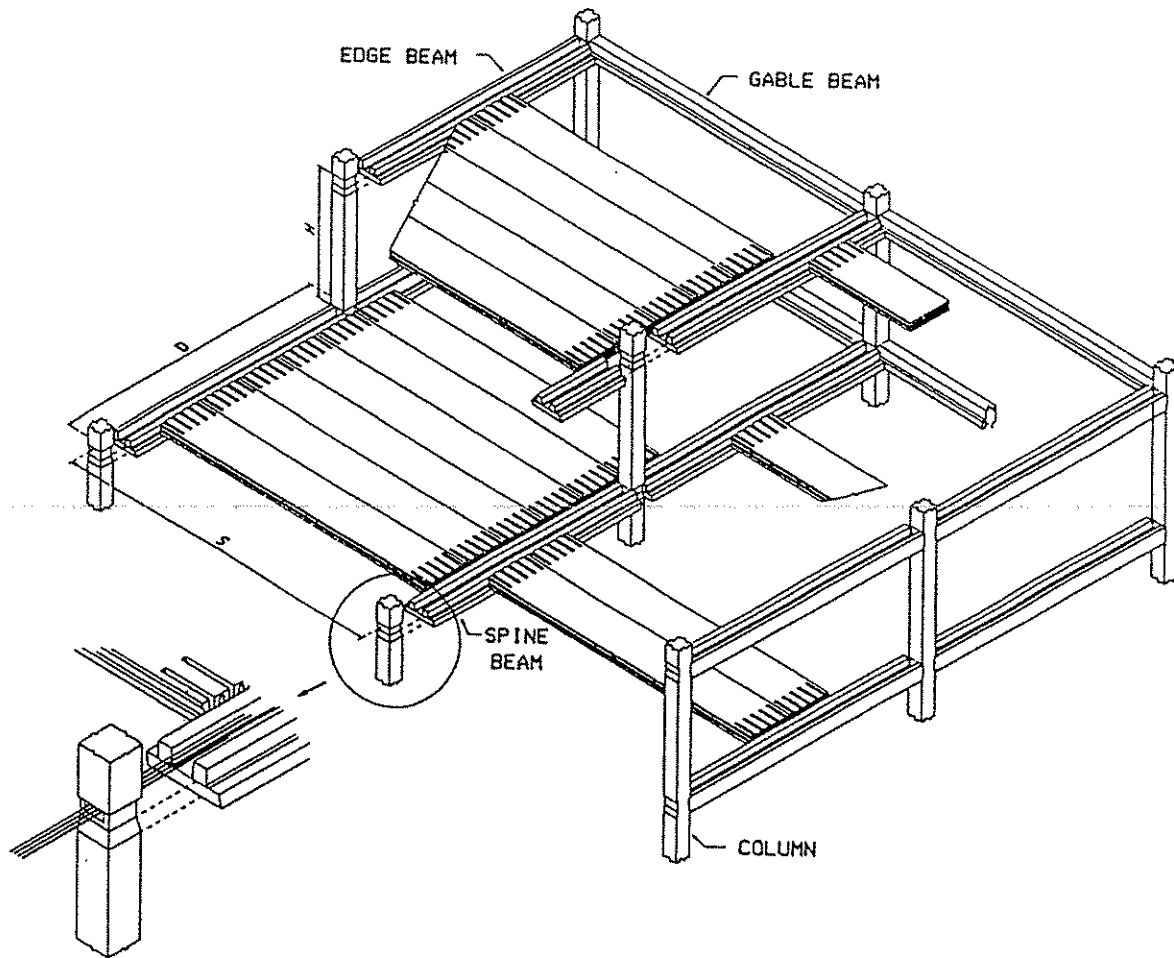

Figure 3.28. Precast structural components. Precast components include spine beams, edge beams and columns. System is post-tensioned from the center of the structure [adapted from Dow Mac 1991].

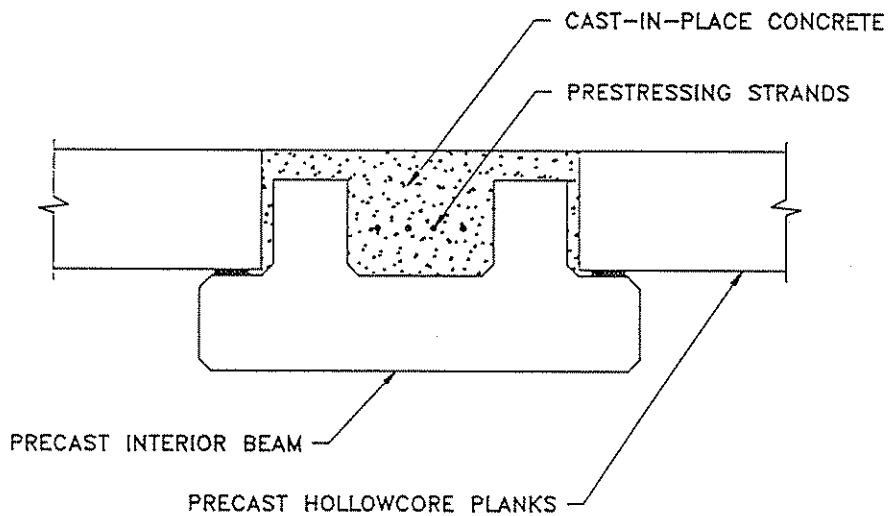

Figure 3.29. Typical spine beam section. Prestressing strands are placed in trough of beam and tensioned.

3.3.3 University of Nebraska System

Developer: University of Nebraska-Lincoln
Omaha, NE
United States

Overview:

This newly developed system is a one way composite beam and column structural system, which minimizes floor thickness in an effort to reduce the total cost of the structure. The key precast element in the system is a pretensioned shallow inverted tee beam which is combined with cast-in-place concrete to form the finished beam element (Figure 3.30). The system eliminates the need for field shoring and requires a small amount of formwork. For office loading, spans of 11 m (36 ft) are possible with a floor depth of 410 mm (16 in.) [Low 1991]. The large bay sizes which can be obtained with the system make it suitable for the office building market.

The precast structural system was developed at the Center for Infrastructure Research, University of Nebraska-Lincoln in 1991. Theoretical work is complete, but full scale testing of the system still needs to be performed. Preliminary cost estimates indicate that the system is competitive in the office building market, when compared with other commonly used precast systems in the United States [Low 1991].

Precast components:

Columns Multi-story columns are precast with blockouts at the beam level to facilitate a monolithic beam-to-column connection using cast-in-place concrete. Horizontal sleeves are precast into the column to enable temporary steel angles to be attached as part of the erection process.

Inverted shallow tee beams The width of the pretensioned shallow tee beam is 2.4 m (8 ft). The beams are voided to reduce self weight and to accommodate services. Grade 60 reinforcing bars are employed and prestressing steel is 1860 MPa (270 ksi) low relaxation 7 wire strands.

Floor units Standard hollow-core planks are used as floor units. In order to keep beam depth to a minimum, hollow-core planks with a weight of approximately 3 kPa (60 psf) should be utilized. Heavier floor units can be used, but the beam depth will be increased.

Structural description:

The proposed structural system is a one way beam-to-column system, utilizing precast beams, columns, and floor members with cast-in-place concrete. Voids are created within the beam to reduce self weight and improve structural performance. Beam continuity is achieved using cast-in-place concrete and field placed reinforcement for negative moment. A steel cage is inserted in the transverse direction in the cast-in-place joint through the column cavity (Figure 3.30b). This reinforcement is provided to resist transverse tensile and shear stresses and transfer loads from the precast floor units to the columns. The top flange of the beam is blocked out in

the precast plant, and constructed of cast-in-place concrete after field reinforcing steel is placed. For diaphragm action a cast-in-place topping can be placed on the hollow-core slabs. If more continuity is desired in the direction transverse to the beam, wire inserts can be used to connect the beam to the floor units. The joints of these connections would then be grouted [Low 1991].

Beam depth is dependent upon bay size and loading. Analysis indicates that a 410 mm (16 in.) inverted shallow tee beam is sufficient under a superimposed dead load of 1.7 kPa (35 psf) and live load of 2.4 kPa (50 psf), for a 10.8 m (36 ft) span. The flange thickness is 203 mm (8 in.) and hollow-core planks are 203 mm (8 in.) deep producing a structural floor depth of 410 mm (16 in.) [Low 1991].

Construction sequence:

·Multi-story precast columns with blockouts at beam level are first set on the foundation or the floor below. Steel angles are bolted to the column below the column blockout, and shoring for the cast-in-place column joint is placed as shown in Figure 3.31, stage I.

·Beams are placed between the columns on the temporary steel brackets. No intermediate shoring is required (Figure 3.31, stage II).

·Steel reinforcement cages are inserted through the column (within the column longitudinal reinforcement), as shown in Figure 3.31, stage III.

·Negative moment reinforcing steel is placed in the trough of the inverted tee beam, and through the column blockout as shown in Figure 3.31, stage IV. This reinforcement is extended to the edge of the top flange to meet development length requirements.

·Concrete for the column blockout joints, and the top flange of the inverted tee beam is placed (Figure 3.31, stage V). Voids can be maintained in the inverted tee beam by using cardboard tubes, inflatable tubes, encased aggregates, polystyrene insulation boards, or steel void forms.

·Once the cast-in-place concrete strength has reached adequate strength, temporary supports and formwork can be removed (Figure 3.31, stage VI).

·Hollow-core planks are then placed on the bottom flange of the interior beams (Figure 3.31, stage VII).

Incorporation of HVAC, plumbing, and electrical systems:

This structural system allows for the possibility of utilities to be contained within the precast beam component, resulting in no increase in floor depth due to services. The proposed concept recommends that the voids be divided into two spaces; electrical and air supply as shown in Figure 3.32. The beam would be precast so access could be made to equipment on the floor above and the floor below.

Modified System

A modification to the system described above has also been proposed by the University of Nebraska [Low, Tadros, and Nijhawan 1991]. The shallow inverted tee beam is entirely precast, with the thickness of the top flange increasing from 90 mm (3.5 in.) at 1.5 m (5 ft) away from the support to a full depth of 410 mm (16 in.) at the support. The main advantages of this system are: cast-in-place concrete is not required during erection, beam forming is simplified, and beams are pretensioned for both positive and negative moments. With this "dry" system, beams are spliced at a distance 1.5 m (5 ft) from the face of the support. As shown in Figures 3.33a and 3.33b, steel plates are embedded in each end of the beam, and spliced together with bolts. A 0.305 m (1 ft) strip of fresh concrete is used to cover the steel plates and bolts for fire and corrosion protection.

The system can be altered to facilitate either single or multi-story construction. With single story construction, sleeves are embedded within the beam to allow column reinforcement from the lower column to pass through the shallow inverted tee beam and into the upper column. A mechanical bar splice is used for the column-to-column connection. A layer of grout is applied on both the top and bottom of the beam at the bearing area. In multi-story column construction the beam slips over the column onto a transverse steel rod which protrudes from the column. The steel bar transfers all beam loading to the column. The gap between the beam and the column is filled with energy absorbing material.

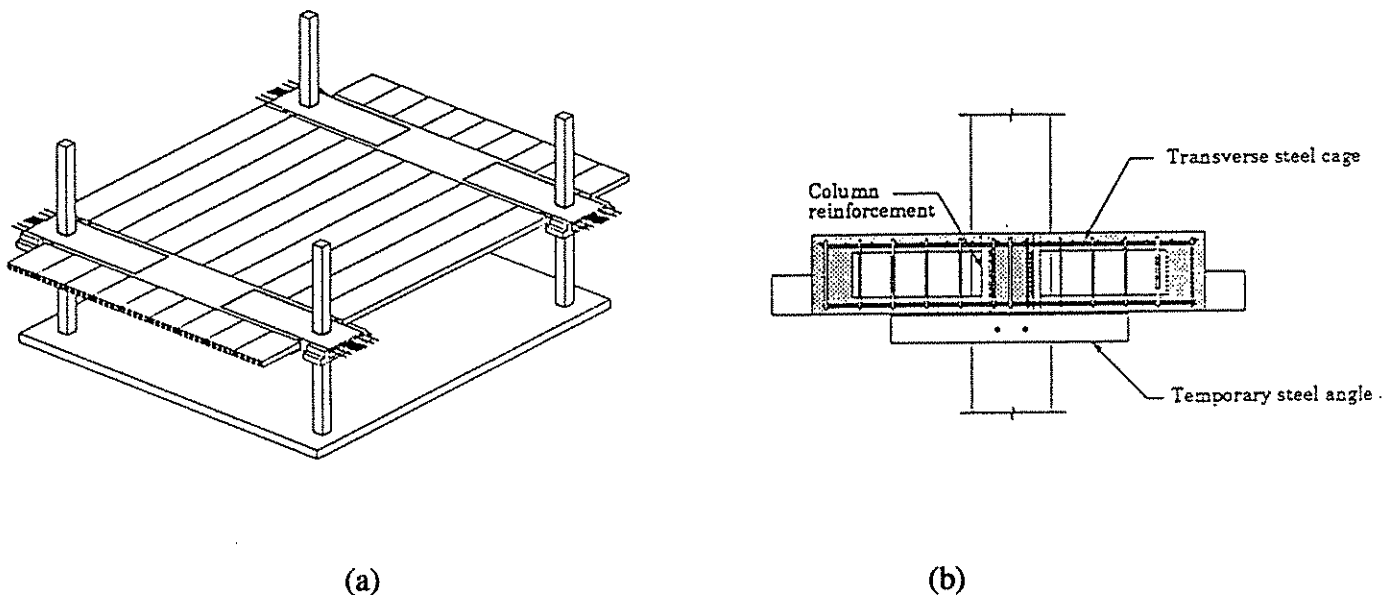

Figure 3.30. Proposed structural system [adapted from Low 1991]: a) Overview of system; b) Beam-to-column detail.

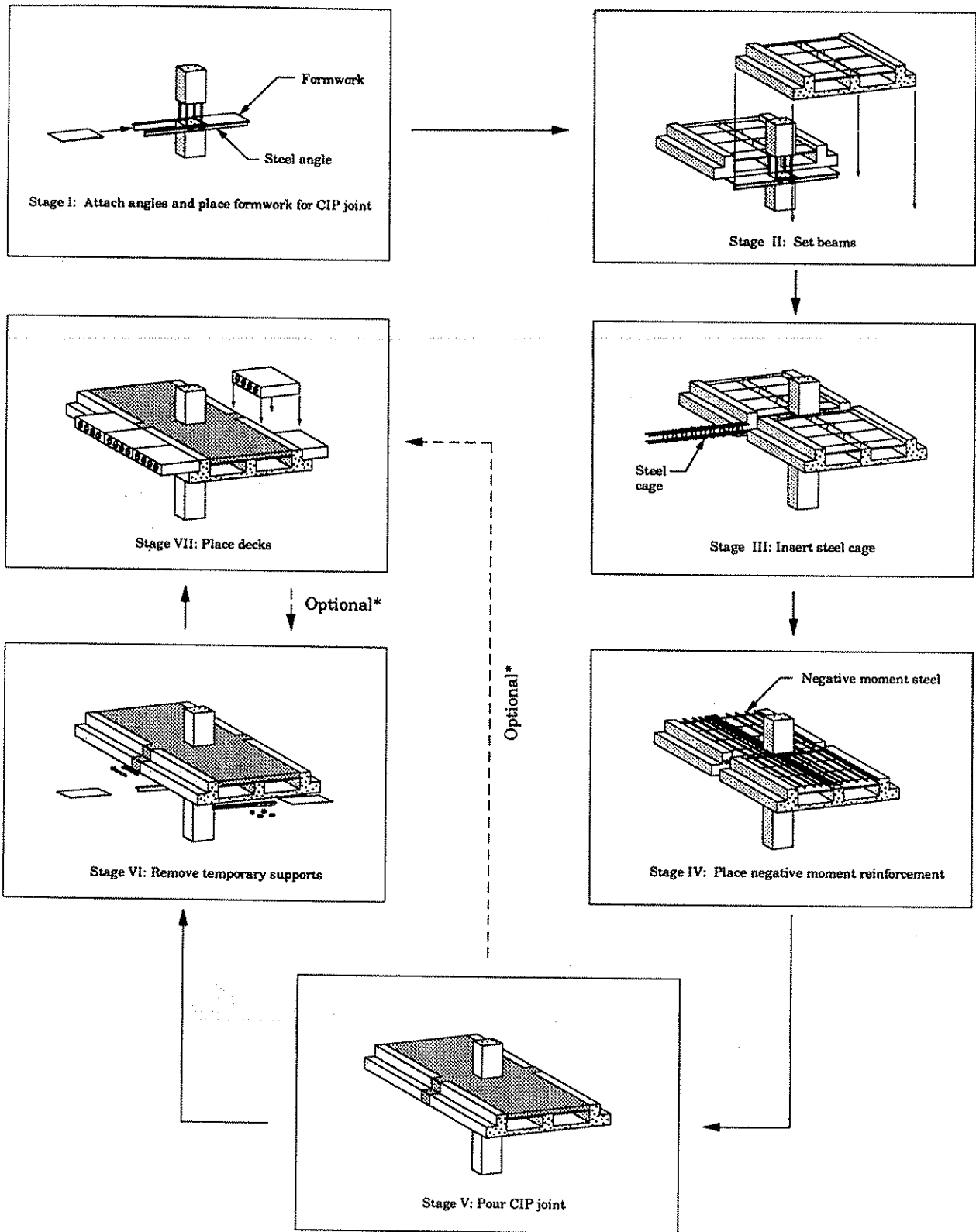

Figure 3.31. VII stage construction sequence [adapted from Low 1991].

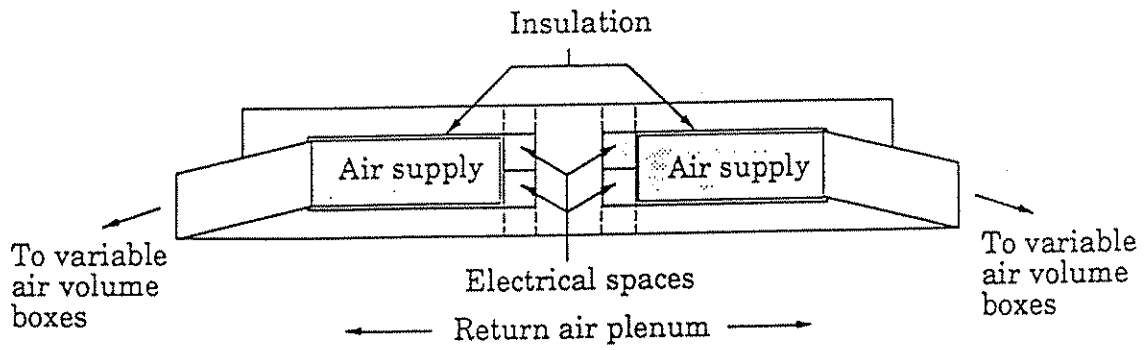
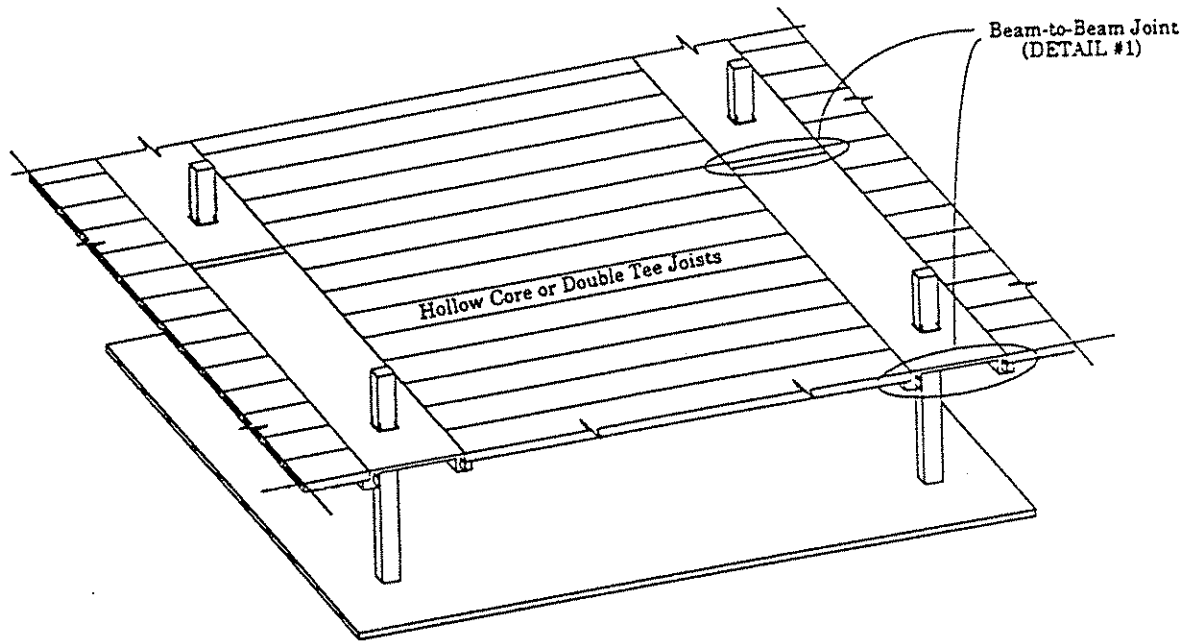
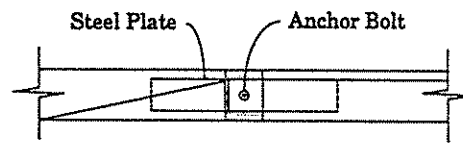

Figure 3.32. Voids in proposed beam can house electrical and HVAC services [adapted from Low 1991].



(a)



Section A-A

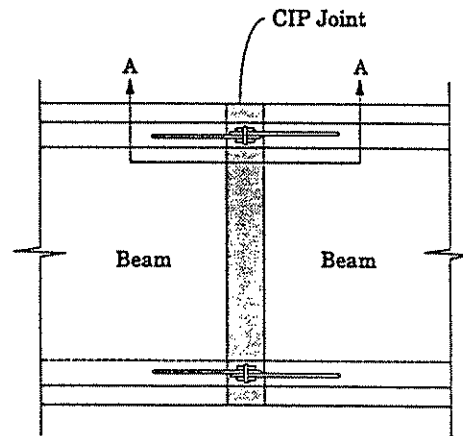

Plan

(b)

Figure 3.33. Modification to system [adapted from Low, Tadros, and Nijhawan 1991]: a) Overview of system; b) Beam-to-beam detail (Detail #1).

3.4 PRIMARY COMPONENTS OF ADDITIONAL SYSTEMS

3.4.1 Cruciform Elements

Overview:

Cruciform elements have been widely used in the construction of precast concrete moment resistant frames. A major concept of this structural system is to join precast components at a distance away from the high moment region of the beam-to-column interface. Two cruciform elements are shown in Figure 3.34. A two dimensional cruciform element is shown in Figure 3.34a and a three dimensional element is shown in Figure 3.34b. Cruciform elements are also referred to as "beam-column trees" or "H Frames".

Cruciform elements have been used in the United States, Europe, Japan, and New Zealand. The Ala Mona hotel in Honolulu, Hawaii made extensive use of "tree" or cruciform elements similar to that shown in Figure 3.34b. Constructed in 1970, this 38 story precast concrete building was designed for seismic zone 2 conditions and is the tallest precast structure of its kind in the world [Warnes]. Recently a similar frame was erected to a height of 37 stories in seismic zone 4+ in Tokyo, Japan [Ericson and Warnes]. The primary component of the PG Connection system, which is described in section 3.2.5.2, is a two dimensional cruciform element.

Connections:

Connections between precast cruciform elements emulate cast-in-place concrete construction, producing monolithic beam-to-column connections. The joint between components is located in regions requiring reduced moment resistant capacity.

Horizontal Joints - In order for connections between beam ends to perform monolithically, it is necessary to couple the reinforcing bars and to make a closure with cast-in-place concrete. Several methods are available for making structural splices of horizontal reinforcing bars. Bars may be lapped according to code-prescribed lap lengths. A modification of this approach is to confine the lapped bars with steel spirals. A third option is to use mechanical splice connections as shown in Figure 3.35. Reinforcing bars may also be joined by welding. Bars may be butt or lap welded [Warnes 1991]. An alternative to the above methods, which does not emulate cast-in-place methods, is to embed steel plates in the precast beam members. The steel plates are simply bolted together during erection.

Vertical Joints - Column-to-column connections are typically located at the mid-height of the column. Typically reinforcing bars are joined with mechanical connectors and the concrete interfaces between the elements are joined with high strength grout.

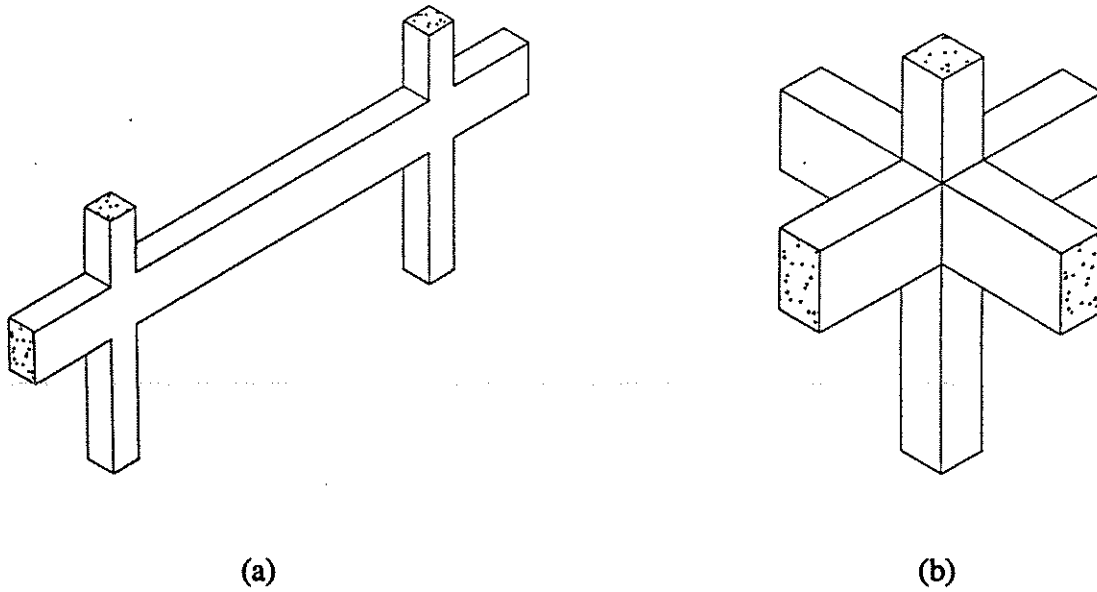

Figure 3.34. Cruciform Elements: a) Two dimensional element; b) Three dimensional element.

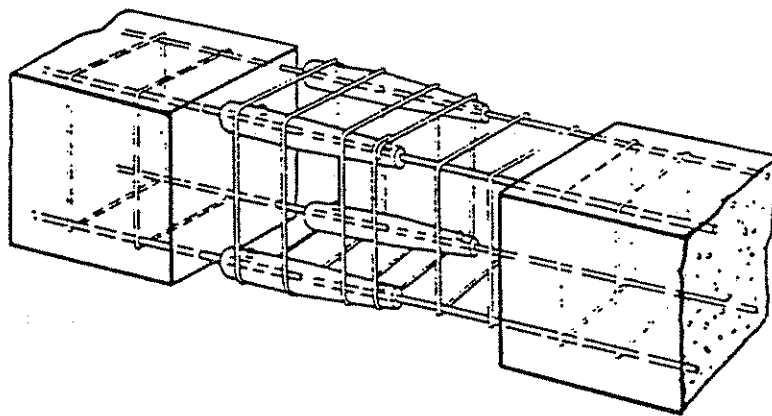

Figure 3.35. Beam-to-beam mechanical splice connection [adapted from Warnes 1991].

3.4.2 OHS Beam-to-Column Connection

Developer: Østspenn
Østlandske Spennbetong A/S
N-3501 Honefoss
Norway

Overview:

Developed by Østspenn in the late 1980's, the OHS Beam-to-Column Connection has been used for multi-story residential buildings, office buildings, parking garages, recreational facilities, and industrial buildings [Alexander 1990]. There are three principal types of beam-to-column connections in the OHS System: BSF, BSI, and BSIG. The BSF connection, the most commonly employed of the three connection types, is a shear connection which allows for small horizontal movements. The BSI connection is a full moment connection, and the BSIG is a two-sided moment connection which allows for movement along the longitudinal axes of the beam.

The connection system can be used with rectangular beams, as well as inverted tee beams and ledger beams. Beams can be connected to rectangular or cylindrical columns from 1, 2, 3, or 4 sides. According to Østspenn, other advantages include [Østspenn Holding A/S 1991]:

- Quick erection (3-5 minutes per beam).
- Corbel free concealed connection.
- No bolting or welding.
- No formwork at the site.
- Horizontal movement of the beam allows for temperature and shrinkage.
- Reduces required space for storage and in transport.
- Time savings in design and drafting.

Connection:

The BSF shear connection consists of three units (Figure 3.36): 1) splitbox - a steel unit encased in the column; 2) slidebox - steel unit encased in the beam; 3) knife - a steel plate which slides from within the slidebox, into the splitbox, where it is hooked. The connection is available in three standard loading classes. The BSF 150 can accommodate ultimate loads of 250 kN (56 kips). The BSF 200 can accommodate ultimate loads of 350 kN (79 kips), and the BSF 300 connection is effective for loads of 500 kN (112 kips) [Østspenn Holding A/S 1991]. Minimum beam dimensions for each type of connection are as follows:

BSF 150.....200 x 400 mm (7.9 x 15.7 in.)
BSF 200.....200 x 500 mm (7.9 x 19.7 in.)
BSF 300.....300 x 500 mm (11.8 x 19.7 in.)

A great deal of attention must be paid to tolerances during production of the precast components. Østspenn has developed techniques in its Østlandske precast plant to improve the placement of the slidebox and splitbox in the precast components [Østspenn Holding A/S 1991]. A further consideration is that the beam must be suspended horizontally during placement, so a

quick and accurate connection can be made with the column. The beam manufacturer gives consideration to where lifting inserts should be placed to ensure this. As the beam is lifted into place, the steel knife is retracted completely within the housing of the slidebox. When the beam is positioned against the column, the knife is pushed out of the beam and into the column splitbox. This procedure is performed by inserting a "pry bar" tool into the top of the slidebox housing. Once the knife is hooked into the splitbox, adjustments are made to obtain the same joint spacing at both ends of the beam. These adjustments are made with the same tool which was used for pushing the steel knife out of the slidebox. If necessary the beam-to-column connection can be grouted to resist torsional movement. The only formwork necessary for this is a polyethylene strip pressed into the joint along the sides and underneath the connection gap.

From cost information supplied by Østspenn, it appears the connection is economical when compared with traditional beam-to-column connections. Data indicates that an average material and labor savings equivalent to \$57 per connection is achieved when the system is used in Norway. The company anticipates that the connection will be easily adapted to automated construction, and that further cost savings will be realized [Thoresen 1990].

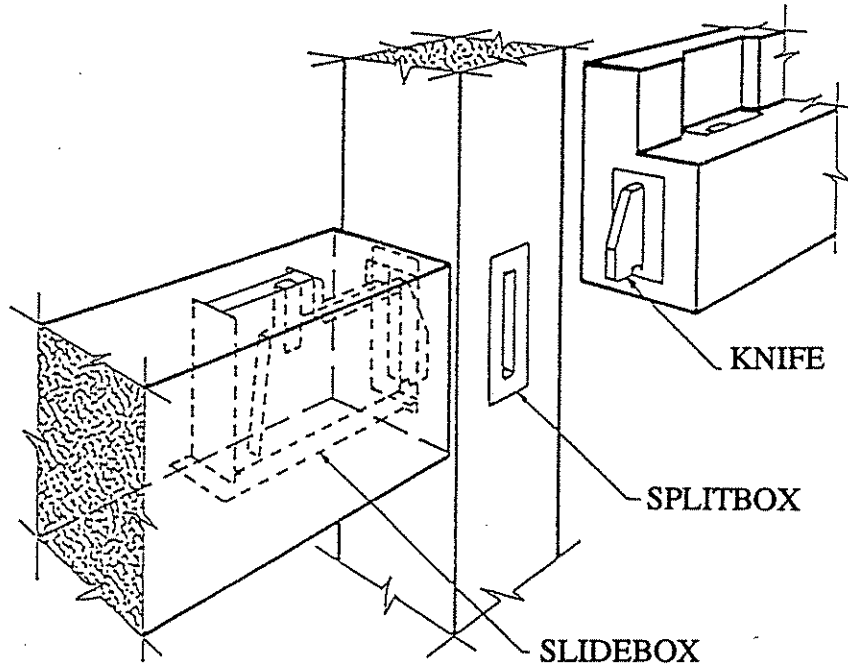

Figure 3.36. The BSF prefabricated beam-to-column shear connection. The steel knife from the beam is slipped into the column splitbox [adapted from Østspenn Holding A/S 1991].

3.4.3 Trent T6 Connector

Developer: Trent Concrete Structures Limited
Colwick Industrial Estate
Nottingham NG4 2BG
Great Britain

Overview:

The Trent T6 Connector is a unique form of structural connection between columns and beams. The connector is fabricated from standard hot rolled steel shapes and consists of three components: a column unit, a seating cleat, and a beam unit. Trent Concrete Structures maintains that the connection combines the strength and versatility of bolted structural steel-to-steel connections with the design flexibility, inherent fire resistance, and economy of precast concrete [Trent Concrete Structures 1992].

The T6 connection system was developed with the assistance of the University of Nottingham Civil Engineering Department, where full size prototype connections were tested. Patented in 1967 [Trent Concrete Structures 1992], the connection has been used on hundreds of buildings throughout Britain and under license agreements by overseas manufacturers. Commonly used in multi-story office buildings, retail structures, and parking garages, this precast structural system is competitive with both cast-in-place and fabricated steel construction for buildings of 1 to 3 stories [Trent Concrete Structures 1992].

Connection:

The T6 beam-to-column shear connection uses a steel-to-steel bolted structural connection between precast beams and precast columns. Manufactured from rolled steel shapes, the connection consists three basic parts (Figure 3.37): 1) a column unit cast into the precast columns at the beam level; 2) a stiffened cleat which is bolted to the column unit after the column has been cast; and 3) a beam unit cast into the ends of the beams.

The connection requires a high level of quality control during precasting to ensure that the column and beam unit can be placed properly in the field. Main beams are erected onto the T6 cleats projecting from the column and are packed and leveled on steel shims as necessary, prior to the tightening of the bolts. Formwork is constructed around the joint and filled with grout [Trent Concrete Structures 1992].

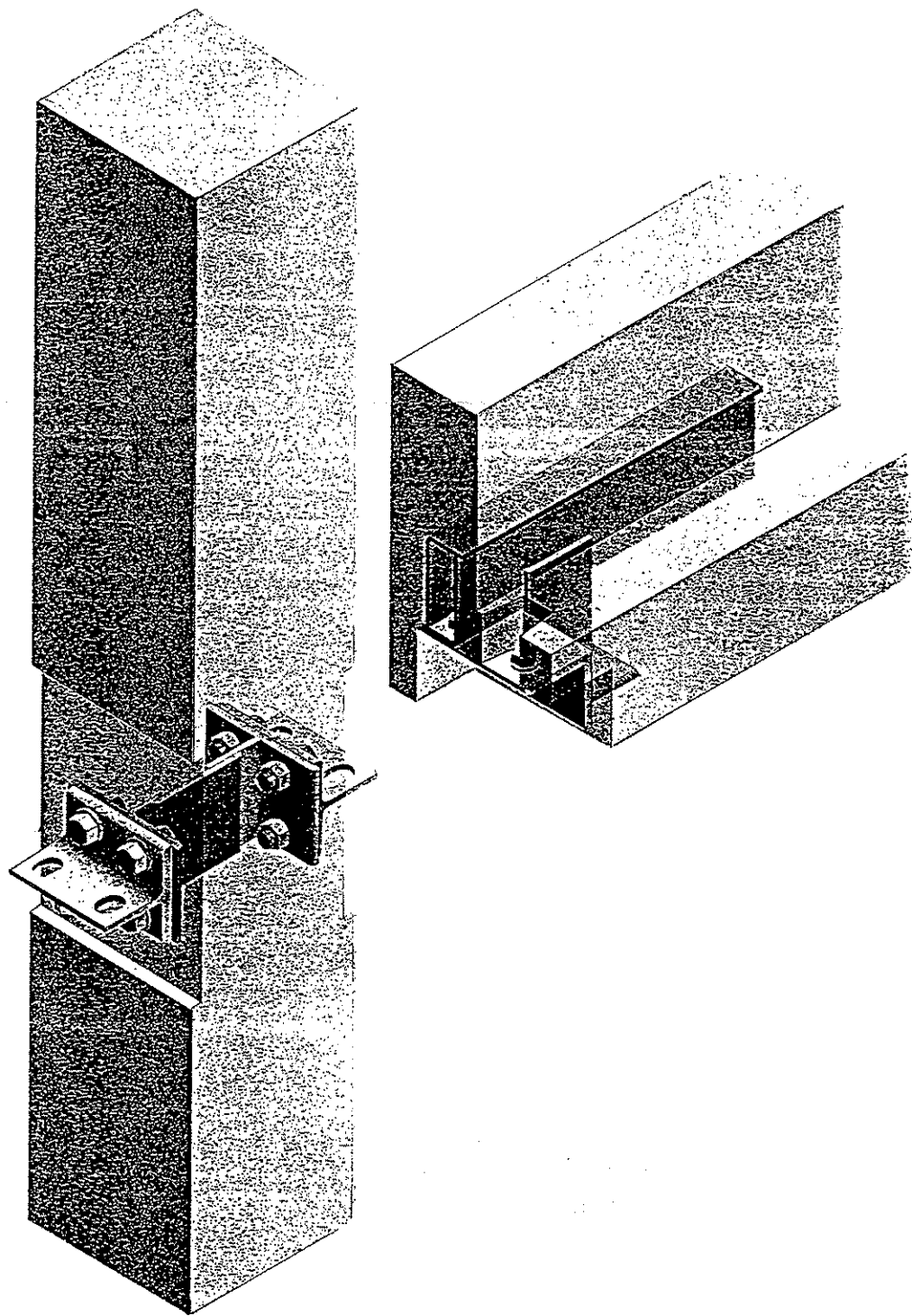

Figure 3.37. Bolted beam-to-column connector [adapted from Trent Concrete Structures 1992].

Chapter 4

Criteria

4.1 INTRODUCTION

The assessment criteria presented in this chapter were developed to provide a consistent basis for evaluating the precast structural systems in the survey (Chapter 3) as well as any new systems which are developed by the research project. A criterion is a characteristic of the structural system or of its interaction with other systems in the building which allows a judgement to be made about the effectiveness of the structural system. In Chapter 5, comparative measures are developed for some of the criteria for use in evaluating each structural system.

An example of a criterion is *truck requirements*. If transportation of precast structural elements from the precast plant to the construction site is considered to be a significant criterion for a precast system, then the efficiency of the transportation operation should be evaluated. As one approach, this could be measured in terms of the number of truck trips required to transport precast elements from the plant to the construction site.

4.2 PRELIMINARY CRITERIA

Information gathered from industry professionals was used to develop a preliminary set of criteria for evaluating precast structural systems. These criteria are characteristics of the complete building system that are impacted by the precast structural system. Each characteristic refers to the impact of the structural system on the efficiency or performance of the overall building system. The criteria are considered preliminary because further verification of the criteria is needed, as discussed later. In order to better organize these criteria they are divided into three primary categories: Structural, Service, and Architectural (Figure. 4.1).

Criteria in the Structural category identify how effectively the precast structural system meets the structural needs of the overall building system. To completely evaluate the structural system, it is necessary to determine how efficiently the structural system can be constructed and how well the structural system performs. A similar approach is taken to determine the impact of a precast structural system on the HVAC, plumbing, and electrical service systems. Criteria in the Service category address both the accommodation of the service systems and the performance of these systems. Criteria in the Architectural category identify the impact of the structural system on the architectural aspects of the building, in particular the dimensions and function of architectural spaces and the performance of architectural finishes and enclosures.

Each of the three primary categories is divided into two subcategories. The first subcategory, entitled Efficiency, pertains to the design, construction, and operation phases of the building. These criteria are generally measured in terms of time and money. The second subcategory, entitled Performance, pertains to the ability of the system to meet its designed function and/or to adapt to a different function. These criteria are measured in qualitative terms. Specific measures for certain criteria are discussed in Chapter 5.

4.2.1 Structural

The Structural criteria are organized into two sub-categories entitled Efficiency and Performance as shown in Figure 4.1. The Efficiency category contains criteria which pertain to the effectiveness of *structural design, structural fabrication, transportation, and structural erection*. The Performance category contains criteria which pertain to the function/behavior of the structural system. Three performance criteria are addressed: *strength, stability, and structural serviceability*.

4.2.1.1 Efficiency

Structural Design - This criterion addresses the design effort which is required for a particular precast structural system. The design of the structural system accounts for a small percentage of the total building cost, and from interviews it was found that design effort does not differ significantly between precast structural systems in the survey. As a result, structural design has not been investigated in detail. However, one issue which is important in the design process is the coordination between the structural designer and the mechanical designer. This issue is addressed in Section 4.2.2.

Structural Fabrication - The fabrication criteria address the efficiency of producing precast components. Three criteria are considered: *fabrication operations, coordination between fabrication operations, and method of fabrication*. Each criterion has an impact on the total cost of fabrication.

Fabrication Operations - The total cost of fabrication is affected by the cost of labor, materials, and the number of pieces that need to be fabricated. While the quantity of labor is important, the type of labor is also important, since each labor specialty receives a different pay rate. In addition, the cost of both materials and labor is significantly affected by geographic location and this cost differentiation requires consideration in evaluating fabrication efficiency. The tasks/operations required in fabrication can be broken down into the following four areas:

- Construction of forms - From the interviews it was found that the number of different forms and the complexity of the forms have a major impact on fabrication costs. While the cost of a form is small in comparison to total construction costs, cost does become a factor if a number of new forms are required with the precast structural system. Advantages exist with systems which reduce the number of different pieces, because the number of forms is reduced, and the material and labor cost associated with additional forms can be eliminated.

The complexity of the form also impacts the cost of constructing the form. Complex end geometry, such as that shown for the floor planks of the PD2 Frame (Figure 3.17), result in higher form costs. However, a form for a precast component such as a floor plank can be used repeatedly and as a result the cost can be spread over many units. The complexity of the form is also a function of the number of minor variations between different precast pieces. These minor variations may not require the construction of new forms but instead may use blockouts which are inserted in the form. If only a small number of blockouts are

required or if the blockouts are on a module then the impact of these minor variations on the cost may be insignificant.

- Placement of steel plates, bars, and strands - The major consideration with this aspect of fabrication is congestion in the form. The area of a precast member which connects to an adjoining member requires additional reinforcing steel, embedded plates, and inserts. With access only from the top of the form, much of this hardware must be threaded in and around other items, causing increased fabrication costs [Martin 1982]. Martin [1982] indicates that in some cases it may be economical to increase the size of the precast member to accommodate the steel hardware. Congestion of reinforcement may also limit the use of draped prestressing tendons, if shear and longitudinal reinforcement interfere with the tendons.

Based on interviews, it appears that standard dimensional tolerances on the placement of steel plates, bars, and strands are not difficult to achieve in the precast plant, and that alignment of steel plates for the welded connections between precast components is not a problem. Precasters also indicated that the required tolerances associated with mechanical splices can be easily achieved in the prefabrication plant. However, dimensional tolerances that are more rigid than industry standards are difficult to achieve in the precast plant.

- Concrete placement - The participants in the interviews indicated that, in their opinion, concrete placement and finishing of precast members is an efficient operation in the precast plant.

- Stripping and Handling - A number of items must be considered in stripping the form from the precast member. The orientation of the member (horizontal, vertical, or some angle between) will impact the efficiency of stripping the form. For example, the inverted double tee members of the Triposite system (Section 3.2.13) would be cast as double tees and then the component would need to be rotated. This would be difficult in precast plants which do not have a rotating table. Member geometry will affect form suction and will impose stresses on the component during stripping. The member weight and the weight of any additional items which must be lifted (such as forms that remain with the item during stripping) must also be considered [PCI 1992]. The available crane capacity is a consideration in both the plant and the construction site, but most fabrication plants can accommodate the production of very large members without difficulty. The size of members is more typically limited by transportation requirements.

Coordination Between the Fabrication Operations - According to interviews, coordination between the different fabrication operations described above is usually a very efficient process in the precast plant. Each plant is organized to ensure that time delays between operations are minimized.

Method of Fabrication - An additional consideration is the method of fabrication which is utilized. If the precast components lend themselves to mass production then the precast operation is more efficient. Components with complicated end geometry because of the connections cannot use "long-line" production methods and hence have higher fabrication costs. The production of hollow-core planks is a case where mass production techniques are utilized. The plank is cast in a long bed and then cut to the required lengths. Although a number of different methods are used to fabricate hollow-core planks, all are estimated to be approximately equal in production costs.

Efficient fabrication is also a function of the repetition associated in the precast fabrication process. The actual cost of constructing different forms is not addressed here but rather the loss or gain in worker productivity associated with repetition. If a precast system requires a large number of different precast components then repetition is reduced and productivity is decreased. Alternately, a precast system with only a few different precast components is more efficient to fabricate because of the large amount of repetition.

Transportation - The transportation criteria address the efficiency of transporting precast components from the fabrication plant to the construction site. The primary efficiency measure is the number of truck trips required. There are two criteria which are considered here: *permit requirements*, and *truck requirements*.

Permit Requirements - Permit requirements vary in each state. In some states, a total height (road-bed to top of load) of 4.11 m (13.5 ft) is allowed without special permit. The maximum width varies among states from 3.05 to 4.27 m (10 to 14 ft). Some states allow lengths over 21.34 m (70 ft) with only a simple permit, while others require, for any load over 16.76 m (55 ft), a special permit, and escorts front and back [PCI 1992]. Efficient transportation may involve exceeding the 178 kN (20 ton) weight limit and obtaining special weight permits. In some states, weights up to 890 kN (100 tons) are allowed with permit, while other states there are very severe restrictions on loads over 223 kN (25 tons) [PCI 1992].

Truck Requirements - The size and weight of precast components is often controlled by transportation requirements. The common payload for standard trailers without special permits is 178 kN (20 tons) with width and height restricted to 3.05 m (10 ft) and length to 12.19 m (40 ft). Low-boy trailers allow the height to be increased. However, low-boys cost more to operate and have a shorter bed length.

If the precast component exceeds the weight capacity of standard transport equipment, then a higher capacity or "special" truck is required. Information from interviews indicates that it may be economical to exceed weight limits in particular circumstances since the number of truck trips is reduced and large precast members can reduce erection costs.

The erection schedule will dictate the order or sequence that pieces need to be transported to the site. An efficient precast system will optimize the truck capacity while meeting sequence requirements. Precast components which "fit together" allow more components to be transported with each truck trip. For example, a 98 kN (11 ton) unit may not be economical because only one can be shipped per load, while two 89 kN (10 ton) units could be shipped on one load [PCI 1992].

Structural Erection - The erection criteria address the construction of the precast structural system. Two criteria are included in this category: *erection operations*, and *coordination between erection operations*.

Erection Operations - As in fabrication, the total cost of erection is affected by the cost of both labor and materials. While the quantity of labor is important, the type of labor required is also important, since each labor specialty receives a different pay-rate. Geographic location has a significant impact on the cost of materials and labor, and the availability of a particular labor specialty also varies with location. Environmental conditions also impact the efficiency of field work. The erection operations required can be broken down into the eight items described below.

- **Handling** - The number of precast pieces to be handled is a major consideration. Based on information gathered in the interviews, a typical cost associated with handling is \$500 for every crane pick. Erection is facilitated when the orientation of members during transport is the same as their final orientation in the structure, so that no rotating is involved. Connections should be designed so that the unit can be lifted, set, and unhooked in the shortest possible time. Before the hoist can be unhooked, the precast piece must be stable and in its final position. Some shapes of precast units such as double tees and hollow-core slabs are inherently stable and require no additional connections before releasing the crane. Others, such as columns, wall panels, and single tees, often require supplemental shoring, guying, or fastening before the hoist is unhooked. Planning for the fewest, quickest, and safest operations to be performed before releasing the hoist will improve the efficiency of handling [Martin 1982]. The crew requirements are typically one crane operator, two laborers to rig the member, and two laborers to position and release the member.

Crane size must also be considered. The position of the crane depends on the site, and the method of erection, and will determine the crane size required, since crane capacity is a function of weight and reach. Large cranes with a 1780 kN (200 ton) capacity are readily available.

- **Placement of Reinforcement** - Several factors must be considered in calculating the cost of field-placed reinforcing steel. The quantity of field-placed reinforcing steel is a major consideration, especially in areas where the labor rate for iron workers is high. Many systems, such as Dycore (Section 3.2.3), only require negative moment reinforcing steel over precast soffit beams. Systems which use Filigree type slabs (Section 3.2.5) require field placed negative moment steel across the entire floor system in both principal directions.

- **Concrete Placement** - The requirements associated with cast-in-place concrete vary from system to system but a major consideration is the need for formwork. Many precast systems use precast elements as stay-in-place forms for cast-in-place concrete. Filigree construction uses a large quantity of cast-in-place concrete but eliminates the need for formwork. Many other systems use concrete for a floor finish or topping. Systems which do not use the precast elements as stay-in-place forms have material and labor costs associated with temporary formwork.

the ability of the service systems to meet the required functions and/or adapt to a different function. The criteria under this category are classified as *service capacity*, *serviceability*, and *service versatility*.

4.2.2.1 Efficiency

Service Design - The *service design* criterion addresses how the structural system affects the ease and efficiency of the design process for the various service systems. For example, a ribbed floor and efficiency of the design process for the various service systems. For example, a ribbed floor system, such as the double tee system, presents difficulties in the design of the plumbing system that are not encountered with a reinforced concrete cast-in-place slab, because coordination between the architect, service designer, service contractor and the precast fabricator is needed to locate small vertical openings in the floor system to pass service systems through the floor. The position of vertical openings is limited for a ribbed system since openings cannot pass through the ribs (e.g., the stems of the double tee). Hence, the position of openings must be considered more carefully with a ribbed system than with a cast-in-place slab system, where openings are restricted by the beams only. A similar consideration is required when using prestressed hollow-core planks. In general, no more than one prestressing strand can be cut by vertical openings placed in the field. A reinforced concrete cast-in-place slab would not have these same limitations.

Service Fabrication - The *service fabrication* criterion deals with the efficiency with which the components of the HVAC system can be fabricated. The criterion is limited to the HVAC system since the fabrication of the other services, such as the electrical or plumbing system, does not vary significantly with the use of different structural systems. The HVAC system that is best suited for the particular structural system and intended building function may have certain characteristics which will affect the efficiency with which it can be fabricated. An example of this would be a precast beam member which includes horizontal oval openings. Although oval ducts may make optimum use of the space, they may be less efficient to fabricate than rectangular ducts.

Service Installation - The service installation criteria deal with the impact the structural system has on the efficient installation of the service systems. There are four criteria which affect this efficiency: *method of service installation*, *coordination between structural and service trades*, *space for service installation*, and *installed service position*.

Method of Installation - This refers to the method which can be employed in installing ducts, plumbing, and other equipment. The structural system will dictate how ducts are installed in a precast structure. The U.S. Conventional system (Section 3.2.1), allows the HVAC system to be assembled on the floor and raised into position. This is a very efficient method of installation. Structural systems with openings in the precast members for horizontal service systems to pass through cannot use this method. Portions of the HVAC and plumbing systems have to be assembled from shorter than normal segments in order to accommodate the tight spaces that are often encountered with systems that provide openings for the service systems. This will increase the number of connections required and slow down the installation process.

Coordination Between Structural and Service Trades - Coordination between the structural trades and the HVAC, plumbing, and electrical trades will impact the efficiency of work in the field. Additional requirements for coordination between structural and non-structural trades typically lead to time delays and inefficient use of labor. An example of this would be electrical conduit placed in the cast-in-place portion of the floor slab.

Space for Service Installation - This refers to the space available to the HVAC contractor, plumber, and electrician for the placement of system components and equipment. There are two aspects to the limited space problem which affect the overall efficiency of the installation process. The first is the increase in labor time due to difficult access to the spaces provided for the service systems. The second is the degree of complexity of the system in terms of the number of bends and splices required in each system to maneuver through the spaces provided. For example, if the structural system requires a duct system with many bends and angles, the labor and materials required for the installation of that portion of the HVAC system is greater than if a complicated duct system were not required.

Installed Service Position - This criterion addresses the efficiency of establishing the final position of service system components. The position of components that require small vertical openings through the floor system, and the position of gravity dependent horizontal plumbing runs are considered. Service system components that require small vertical openings (e.g., floor-mounted electrical outlets) may not be given an exact position during the design stage. Installation of these components is complicated by the need to avoid beams, joists, ribs, and other supporting structural elements when cutting vertical openings in the field. Ribbed systems (e.g., the double tee system) have more supporting elements than other systems (e.g., cast-in-place slab-on-beam systems). As noted previously under *service design*, prestressed hollow-core planks also restrict the position of vertical openings cut during installation of services.

Gravity dependent plumbing is also considered by the *installed service position* criterion. Both vent pipes and drain pipes for plumbing fixtures, such as toilets and sinks must maintain a minimum slope. Placing these pipes so that they pass through the horizontal openings provided by a system such as the Duotek system (Section 3.2.2), while maintaining the minimum slope, requires additional installation effort and may be impossible with the clearances provided.

Service Operation - Similar to *service fabrication*, the *service operation* criterion deals primarily with the HVAC system since in general the operation of the other service systems is not affected by the structural system. The operational efficiency of the HVAC system is impacted in several ways by the structural system. The volume of unusable space which must be heated or cooled will affect the overall efficiency. This volume is directly related to the dead space above the ceiling and below the floor, and that space depends on the structural floor system and its accommodation of the service systems.

Another factor which affects efficiency is the location of the HVAC equipment. In some structural systems it is difficult to provide large openings for the vertical and/or horizontal passage of ducts, and so it is not feasible to have the HVAC equipment for the entire building in one location. As a result, the HVAC equipment must be placed in multiple locations and this will have an impact on the overall efficiency.

Service Maintenance - The *service maintenance* criterion addresses the impact of the structural system on the efficient maintenance of the service systems. The key issue in maintenance is the accessibility of services. This issue of accessibility was emphasized by the mechanical design professionals. The degree of accessibility is directly affected by the structural system. If a leak in the plumbing were to develop in a system such as the TrilPosite system (Section 3.2.13), it would be impossible to repair without cutting at least one hole in the floor system. Although access panels are included in that floor system, their spacing and location does not allow access to all the services.

An additional aspect of maintenance is the efficiency of routine service on equipment. An example of this would be a piece of equipment installed between two precast tee stems. Although installation may not be a problem, the clearances provided to service the equipment may be too small, making the maintenance operation more costly.

Service Modification - The *service modification* criterion addresses the efficiency or ease with which the existing service systems could be altered to meet a change in building function either by up-grade, rehabilitation, or replacement. Many of the issues considered previously in the design, fabrication, and installation of service systems also apply here. For example, issues such as the position of planned (during design) and unplanned vertical openings, the fabrication of a new HVAC system, the method of installation of the HVAC and plumbing systems, and the spaces available for modification (upgrade or replacement) of service systems are also important when considering how a precast floor system impacts the modification of the service systems.

4.2.2.2 Performance

Service Capacity - The *service capacity* criterion addresses the impact of the structural system on the capacity of the HVAC system. The capacity of the system refers specifically to the supply and return ducts of the HVAC system, rather than the capacity of the equipment which drives the system. There are several aspects of this portion of the system which are affected by the structural system. An HVAC system that is integrated into the structural system may have certain performance limitations.

One aspect is the capacity of the supply and return ducts. The structural system may limit the size of the horizontal and/or vertical ducts. This limitation will inhibit the optimum performance of the HVAC system. In other words, to achieve a particular air flow per square area of enclosed space it may be necessary to exceed the maximum desirable air velocity in the ducts. An alternative would be to reduce the air velocity and therefore reduce the number of complete air exchanges per unit time in a given space. Either option has drawbacks.

Another aspect is the capacity of the supply and return devices provided in each room. The structural system, in conjunction with the building layout desired by the owner/architect, may limit the size and number of diffusers and returns that can be placed in a given room. For example, a structural system that employs double tees cannot have openings cut in the top flange where the stem is located. The position of openings for distribution and return, given these structural constraints and architectural constraints, can result in a limit on the size and number of distribution and return devices in a given room. This would limit the capacity of the HVAC system in much the same way that undersized ducts would.

Serviceability - The serviceability criteria address the in-service performance aspects of the HVAC system. Two criteria are considered: *vibration of service equipment*, and *noise from service equipment*.

Vibration of Service Equipment - Vibration of equipment produced by unbalanced operating or starting forces can be isolated from the precast structure. The typical solution is to place the equipment on resilient supports. A floor supporting isolated equipment must be stiffer than the isolation system. In general, the floor deflection should be limited to about 15% of the deflection of the mounts [PCI 1992].

Noise from Service Equipment - Noise created by the HVAC system is a major consideration when selecting the type of system to be used. Air velocity in ducts is limited in certain areas of the building to reduce noise. This reduction in velocity leads to larger ducts. The location of equipment is also a consideration. Equipment located on the roof of a building produces more noise than equipment located in the basement of the structure. The type of building constructed will dictate the level of noise which is acceptable. Speculative office buildings often have equipment on the roof, while commissioned office buildings often locate it elsewhere.

Service Versatility - The *service versatility* criterion assesses the flexibility provided by the structural system to accommodate different HVAC systems. A HVAC designer sees this as the number of options available. The maximum number of options exists when the structural system has no impact on the location of the HVAC system. This is never the case, but the level of impact does change between precast structural systems. While integration of the HVAC, plumbing, and electrical systems within the structural system helps to reduce floor-to-floor height, it may also limit the type of service equipment which can be utilized. Systems with pre-designed openings and space restrictions may also limit the options available to the mechanical designer.

4.2.3 Architectural

This category contains criteria which pertain to the impact of the structural system on the architectural system of the building. As shown in Figure 4.1, the Architectural criteria are organized into two sub-categories entitled Efficiency and Performance. The Efficiency category contains those criteria which pertain to *architectural design*, *architectural construction*, *architectural maintenance*, and *architectural modification* of the spatial, functional, interior finish, and enclosure systems of the building. The Performance category contains those criteria which pertain to the ability of the system to meet architectural requirements. The following performance criteria are addressed: *architectural serviceability*, *fire safety*, and *architectural versatility*.

4.2.3.1 Efficiency

Architectural Design - The *architectural design* criterion addresses the impact of the structural system on the efficiency of the architectural design process. The architectural design process includes the layout of functions and spaces in a building, the dimensions of the spaces in the building, as well as the design of the enclosing materials, the interior partitions and the finishes. One example is a modular structural system which results in a more efficient design process

because the modularity can be used in the design of the spaces, enclosing materials, partitions and finishes. However, a modular structural system in which the dimensions are not easily varied may make architectural design difficult since it will not adapt easily to variations in spatial and functional layout. These variations include long-span column-free spaces, large vertical openings in the floor system for shafts and stairways, non-rectilinear spaces, and so on. Structural systems that do not adapt easily to these variations will increase the design effort.

Architectural Construction - The *architectural construction* criterion addresses the impact of the structural system on the efficiency of the construction of the architectural system. For example, the structural system, may enable more efficient construction of an element of the architectural system, such as the building enclosure. A spandrel beam with an exterior ledge to accommodate masonry or cladding is one example. The structural system can also impact the amount of material needed for the architectural system. Structural systems which lead to deep floor systems require more material for the architectural enclosures as compared to structural systems which lead to shallow floor systems. The structural system can also improve construction efficiency by making better use of materials. A structural system which serves both a structural function and an architectural function is one example of material use optimization.

Architectural Maintenance - The *architectural maintenance* criterion refers to the impact of the structural system on the maintenance of the architectural components. For example, a precast system which allows large deflections and/or drift will produce damage to architectural components even though these levels of deflection and drift may be acceptable from a structural integrity point of view. As evidence of this, crack damage to wall panels is a specific item which requires maintenance in some structures. Therefore, the type of structural system can affect the level of maintenance which is required for architectural components.

Architectural Modification - The *architectural modification* criterion addresses the efficiency of modifying an existing building to serve a different functional or spatial arrangement. For example, changing a school into office space may require the relocation of interior walls or partitions. A system which relies on interior load bearing walls for structural integrity is more difficult to modify than an open frame system. Changing the functional or spatial arrangement may also require moving, adding, or filling large vertical openings for shafts and stairways. If the structural system does not enable new openings to be framed in, or old openings to be filled, this type of modification may be very difficult.

4.2.3.2 Performance

Architectural Serviceability - The architectural serviceability criteria address the in-service performance aspects of the building which are considered by the architect and are impacted by the structural system. There are three criteria considered: *noise control*, *thermal storage*, and *weather tightness*. Additional serviceability aspects are addressed in Section 4.2.1.2.

Noise Control - The *noise control* criterion refers to the ability of the architectural system to control noise. The purpose of architectural acoustics is to provide a satisfactory environment in which desired sounds are clearly heard by the intended listeners and unwanted sounds (noise) are isolated or absorbed [PCI 1992]. Concrete is a good sound insulator. Precast concrete walls, floors and roofs usually do not need additional treatments in order to provide adequate sound

insulation. If desired, greater sound insulation can be obtained by using a layer of gypsum board or other building material [PCI 1992]. The control of noise created by impact, such as dropping an object on the floor, generally requires additional measures such as carpeting.

Thermal Storage - This criterion refers to the thermal storage properties of the structure. Concrete construction with its thermal storage properties has an advantage over many other materials. Concrete structures have a mass heat capacity and surface area capable of storing and releasing heat as the interior/exterior temperature and radiant conditions fluctuate. Thermal properties of various weight concretes and standard precast, prestressed elements are provided in the PCI Design Handbook [PCI 1992].

Weather Tightness - The ability of the structure to remain weather tight is dependent on the performance of the exterior structural and architectural components. These architectural components are affected by both the behavior of the structure and environmental effects. Excessive deflection of precast structural components may produce cracks which compromise the weather tightness of the structure. Shrinkage cracks also make the interior of the structure vulnerable to water damage.

Fire Safety - The *fire safety* criterion refers to the level of safety which is associated with a particular precast structural system. Many different types of prestressed concrete elements have been fire tested. These elements include joists, double tees, single tees, solid slabs, hollow-core slabs, rectangular beams, ledger beams and I-shaped beams. These tests have shown that the structural fire endurance of flexural precast, prestressed concrete elements depends on several factors, the most important of which is the method of support. Other factors include size and shape of the element, thickness of cover, aggregate type, and load intensity [PCI 1992].

The method of support has a direct impact on the ability of precast elements to withstand fire. As the precast beam or floor member is heated the member expands. Simple connections accommodate this expansion where fixed connections do not. However, the fire resistance of a continuous concrete beam is generally significantly longer than that of a simply supported beam, because a continuous beam provides negative moment resistance which helps reduce the deflections that occur as the positive moment steel begins to yield from heat generated by a fire below. As a result, a continuous beam lasts longer than a simply supported beam when heated from beneath.

Protection of connections is an additional consideration. Many types of connections in precast concrete construction are not vulnerable to the effects of fire and consequently require no special treatment. For example, gravity-type connections, such as column-to-column connections, do not generally require fire protection. Connections which can be weakened by fire and jeopardize structural integrity need to be protected. The OHS Beam-to-Column Connection (Section 3.4.2) requires additional fire protection to maintain structural integrity. The amount of protection depends on the ratio of the stress in the steel to the ultimate strength of the steel at the time of the fire, and the intensity and duration of the fire [Martin 1982].

Architectural Versatility - The architectural versatility criteria refer to the ability of the structural system to accommodate different spatial and functional requirements. This is a consideration before the building is built, when the architect is defining the spatial and functional requirements. The versatility criteria include *spatial and functional versatility*, and *building height versatility*.

Spatial and Functional Versatility - This criterion addresses the ability of the structural system to accommodate varying dimensions and shapes of the interior spaces. This depends on the spans that can be achieved with the structural system, the ability of the structural system to accommodate large vertical openings (for shafts and stairs), and the ability of the structural system to accommodate non-rectilinear spaces. For example, an architectural system may require a structure with 11 m (36 ft) square bays. This requirement will eliminate many precast structural floor systems that are unable to effectively span this length. In addition, the structural system must accommodate large vertical openings required for service shafts, stairways, and other spaces. These openings can occur in a variety of locations with respect to the column lines, and a versatile structural system will easily frame around these openings. Finally, some structural systems adapt better to non-rectilinear spaces than others.

The span versatility of a structural system can be measured in terms of the range of building types or functions the system is applicable to. For example, a precast structure that meets the architectural functional requirements of an apartment building, may not meet the open space requirements of an office building. The function of the building, as indicated by the architect, would dictate what structural systems could be employed. The relevant aspects of the architectural function include the live load capacity required by the function and the span required by the function.

Building Height Versatility - This criterion addresses the impact of the structural system on the building height. This impact occurs in two different ways. First, the overall height of the building is impacted by the total depth of the floor system including both the structural depth and the depth allocated to services. That is, a deep floor system results in a taller building. This is a special concern when restrictions on building height are imposed by local building codes. For floor systems in which the services are placed within the structural floor depth, the structural floor depth directly impacts the overall height. For precast floor systems in which the services are placed below the structural floor system, the building height is controlled by the depth allocated to the structural floor components plus the depth allocated to services. The second impact of the structural system on building height is a limitation on the number of stories that can be constructed with the system because of limits on dead and live load carrying capacity of the columns or foundation, or because of concerns about stability.

4.3 CRITERIA FOR ASSESSMENT

All criteria described in Section 4.2 have an impact on the efficiency and performance of the overall building system. However, a participant in the construction process may weight the criteria differently depending on the role and objectives of the participant. For example, if an owner's primary objective is to construct an office building which can easily accommodate different tenants, then the owner may consider *service modification* and *architectural modification* criteria to be very important. The criteria described in Section 4.2 have been influenced by industry professionals involved in the design and construction of precast systems, and mechanical (HVAC and plumbing) systems. Further verification of the criteria will require input from other participants in the construction process.

For the preliminary assessment of existing systems conducted in this research, the criteria considered are those which have a major impact on the efficiency and performance of the building system, and those criteria which help identify significant differences among precast

structural systems. The following criteria, highlighted in Figure 4.2, were chosen for the preliminary assessment: *fabrication operations, truck requirements, erection operations, method of service installation, coordination between structural and service trades, service maintenance, service capacity, architectural modification, spatial and functional versatility, and building height versatility.*

It is important to note that *structural design, service design, and architectural design* are not included in the preliminary assessment. *Structural design* is not included because the efficiency of the design effort will not differ significantly between the precast structural systems in the survey. Both *service design* and *architectural design* effort will change between systems, but it was not possible to quantify this change in the preliminary assessment.

It is also important to note that *strength, and stability* are not considered in the assessment. The reason for this is that if strength and stability requirements cannot be met, then it is of no value to assess the precast structural system with additional criteria. Therefore, it is assumed that each system has sufficient strength and stability to meet the requirements of a multi-story office building.

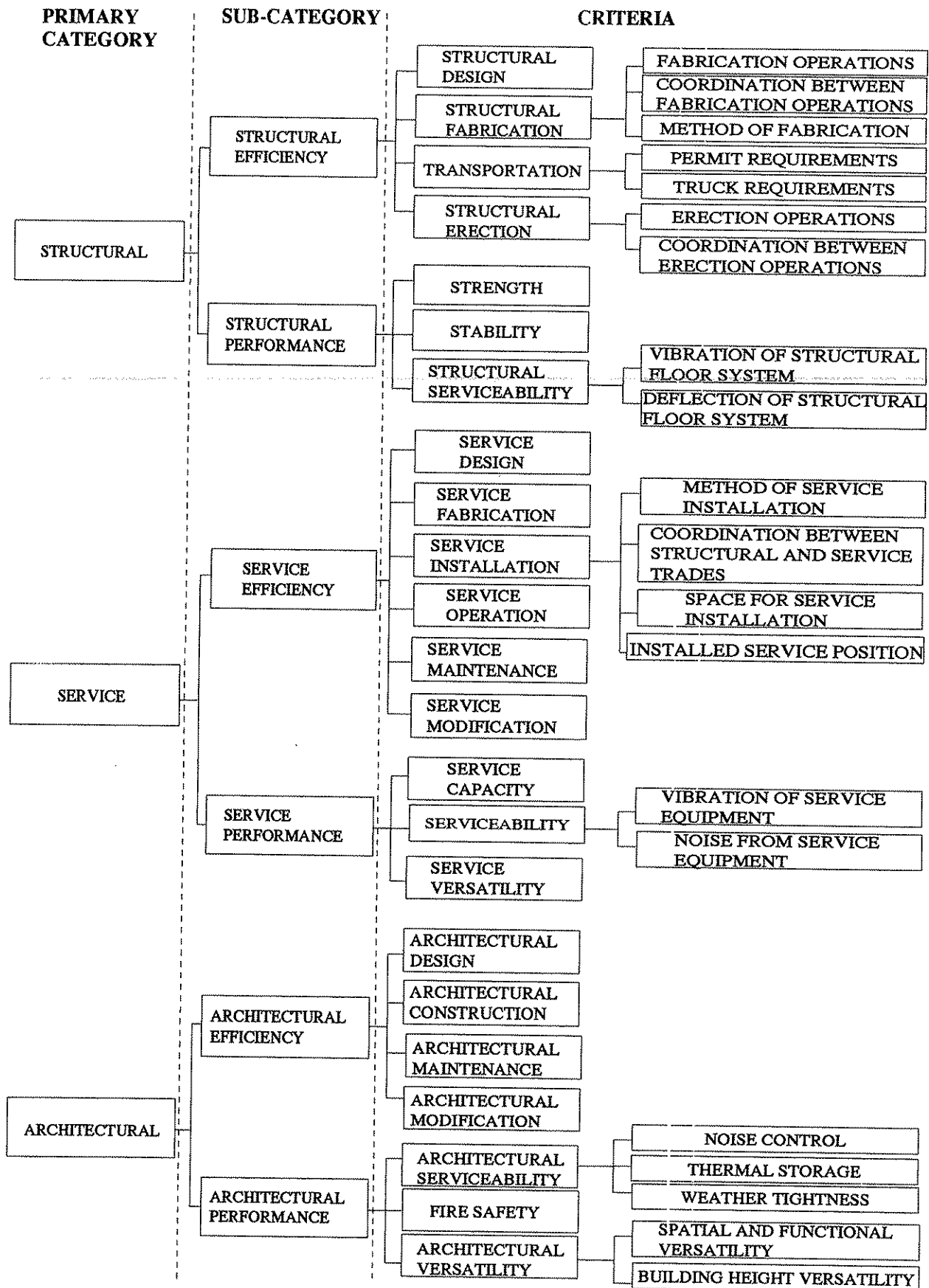

Figure 4.1. Structural, Service, and Architectural criteria.

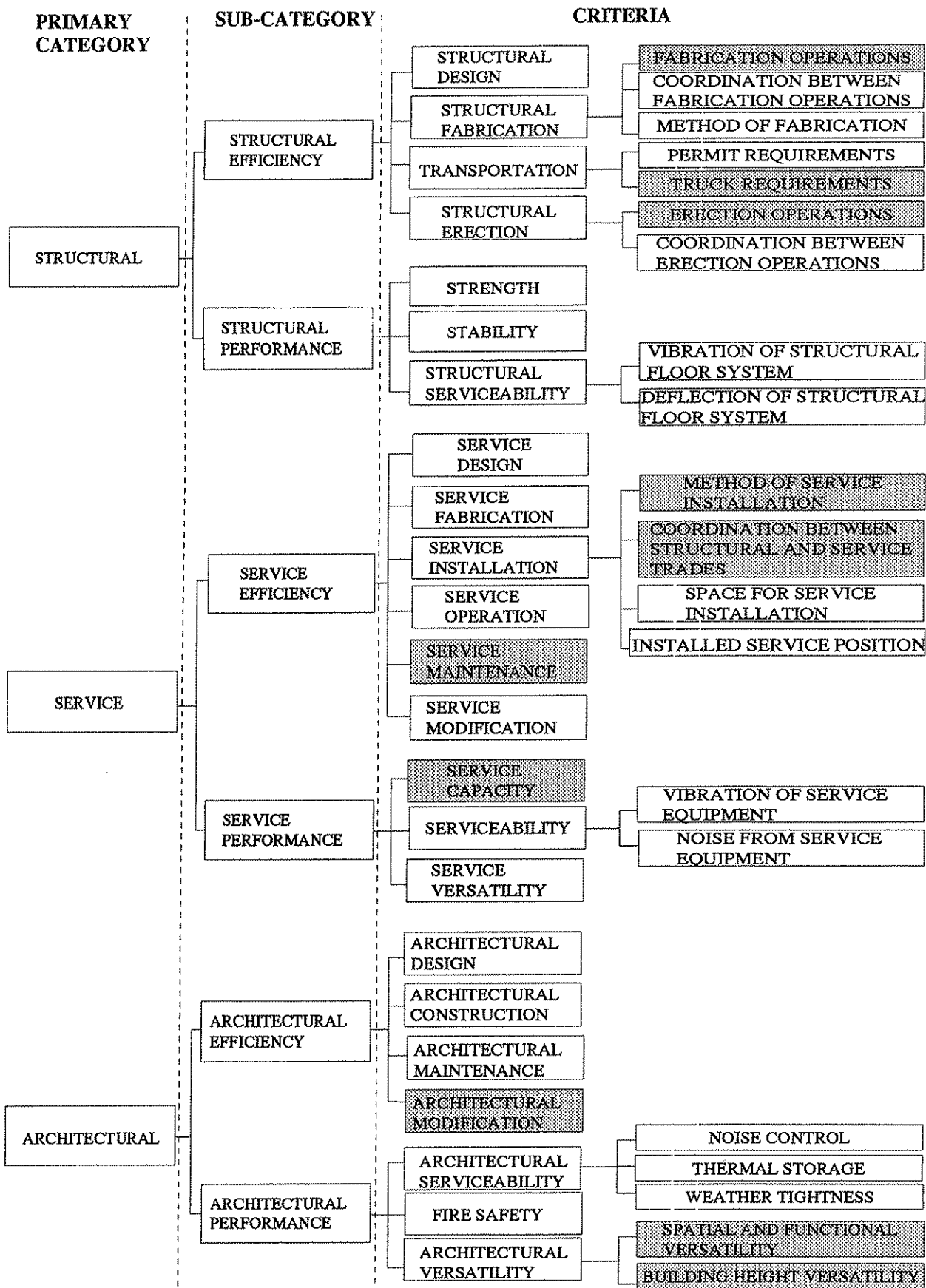

Figure 4.2. Assessment criteria.

1
2
3
4
5
6
7
8
9
10
11
12
13
14
15
16
17
18
19
20
21
22
23
24
25
26
27
28
29
30
31
32
33
34
35
36
37
38
39
40
41
42
43
44
45
46
47
48
49
50
51
52
53
54
55
56
57
58
59
60
61
62
63
64
65
66
67
68
69
70
71
72
73
74
75
76
77
78
79
80
81
82
83
84
85
86
87
88
89
90
91
92
93
94
95
96
97
98
99
100

1
2
3
4
5
6
7
8
9
10
11
12
13
14
15
16
17
18
19
20
21
22
23
24
25
26
27
28
29
30
31
32
33
34
35
36
37
38
39
40
41
42
43
44
45
46
47
48
49
50
51
52
53
54
55
56
57
58
59
60
61
62
63
64
65
66
67
68
69
70
71
72
73
74
75
76
77
78
79
80
81
82
83
84
85
86
87
88
89
90
91
92
93
94
95
96
97
98
99
100

1
2
3
4
5
6
7
8
9
10
11
12
13
14
15
16
17
18
19
20
21
22
23
24
25
26
27
28
29
30
31
32
33
34
35
36
37
38
39
40
41
42
43
44
45
46
47
48
49
50
51
52
53
54
55
56
57
58
59
60
61
62
63
64
65
66
67
68
69
70
71
72
73
74
75
76
77
78
79
80
81
82
83
84
85
86
87
88
89
90
91
92
93
94
95
96
97
98
99
100

1
2
3
4
5
6
7
8
9
10
11
12
13
14
15
16
17
18
19
20
21
22
23
24
25
26
27
28
29
30
31
32
33
34
35
36
37
38
39
40
41
42
43
44
45
46
47
48
49
50
51
52
53
54
55
56
57
58
59
60
61
62
63
64
65
66
67
68
69
70
71
72
73
74
75
76
77
78
79
80
81
82
83
84
85
86
87
88
89
90
91
92
93
94
95
96
97
98
99
100

Chapter 5

Preliminary Assessment of Existing Precast Systems

5.1 INTRODUCTION

This chapter presents a preliminary assessment of the existing precast structural systems described in Chapter 3. In order to assess and compare each precast system, a typical precast office building was chosen to serve as a basis for comparison. A discussion of this example building and two modifications of the building is provided in Section 5.2. Also included in this section is the selection and layout of a typical HVAC system.

Each system is evaluated based on the same criteria, identified in Section 4.3. The criteria chosen for the preliminary assessment were selected because industry professionals indicated that these criteria have a major impact on the efficiency or performance of the building system, and because these criteria help to identify significant differences among precast structural systems. Section 5.3 applies these assessment criteria to the existing systems described in Chapter 3 by developing certain measures for the criteria, and applying the measures to each system. The assessment of the existing systems is provided in Section 5.4.

5.2 EXAMPLE BUILDINGS

To better illustrate the differences between the precast structural systems, an example office building and two modifications of this building were selected. The example buildings allow quantities to be calculated, which serve as measures for many of the assessment criteria. The structural layout and building parameters are provided in Section 5.2.1. An HVAC system is also selected and an approximate calculation of duct sizes is used to determine the impact of the structural floor system on a typical HVAC system. The selection and layout of the HVAC system is provided in Section 5.2.2.

5.2.1 Structural Layout

Example buildings 1, 2 and 3 are four stories in height and 30.5 m x 61 m (100 ft x 200 ft) in plan. The length and/or direction of floor spans differs for each building. As shown in Figure 5.1, example building 1 has 7.62 m (25 ft) beam and floor spans, with floor units spanning in the longitudinal direction of the building. Spandrel beams and interior beams support floor loads, and edge beams are included to develop frame action under lateral force. Example building 2 (Figure 5.2) is a modification of building 1. Floor spans are increased to 15.24 m (50 ft). Example building 3 (Figure 5.3) also consists of 15.24 m (50 ft) floor spans, but the direction of the floor spans is in the transverse direction of the building. Building parameters for the three buildings are summarized in Table 5.1.

5.2.2 Selection and Layout of HVAC System

The three major service systems within the building can be grouped into: electrical, plumbing, and heating, ventilating, and air conditioning (HVAC). While electrical and plumbing services are major systems of an office building, they are often secondary to the HVAC system in terms of space requirements and operation costs. To assess the impact of the structural system on the HVAC system, an HVAC system is chosen which is typical for office buildings.

5.2.2.1 Selection of HVAC System

Office buildings have traditionally used dual-duct, induction, or fan-coil systems. More recently, variable-air-volume systems and self-contained perimeter unit systems have also been used [ASHRAE 1991]. Where fan-coil or induction systems have been installed at the perimeter, separate all-air systems have been generally used for the interior.

A typical HVAC system is chosen for the example buildings based on a number of parameters. Because of the relatively small size of the example buildings, HVAC equipment to serve all four floors of the building can be located in the basement. The vertical shaft for service runs is located in the center of the building. A variable-air-volume (VAV) system is chosen because this type of system is applicable where a cooling load exists throughout the year, such as the interior zone of office buildings. The air supply system introduces varying amounts of constant-temperature air to a space to offset cooling loads and maintain comfort [Grim and Rosaler 1990]. During the heating season, supplementary equipment such as reheat coils must be provided at all spaces with an exterior exposure. As shown in Figure 5.4, the system usually consists of a central air-handling unit with heating and cooling coils, single duct supply system, VAV box, supply duct with air diffuser, return air duct or plenum, and return air fan.

5.2.2.2 Layout of HVAC System

The size of horizontal ductwork is dependent on the size of the zone which must be supplied and also the distance to the zone. A typical layout of horizontal supply ductwork is chosen so approximate duct sizes can be calculated. This layout is shown in Figure 5.5. With the vertical service shaft located in the center of the building it is efficient to use two primary supply ducts, one to each side of the building. It is assumed that a central corridor can be located beneath this ductwork, and that the ceiling can be dropped in this area. Rather than using return ductwork, the area above the suspended ceiling is used as the return air plenum.

Duct design methods for HVAC systems are *equal friction*, *static regain*, and the *T-Method*. The typical procedure is to size ducts by the selected design method, calculate system pressure loss, then select the fan. The system would then be designed in detail, recalculating pressure losses, and re-sizing duct sections to approximately balance pressures [ASHRAE 1989]. For our purposes, a detailed design of the HVAC system is not necessary. However, it is important to have an understanding of the typical space requirements for HVAC systems in office buildings. This information allows us to assess a precast system based on how efficiently it accommodates the HVAC system requirements.

The required air movement for office buildings ranges from 0.0038 to 0.0102 cms/m² (0.75 to 2 cfm/ft²) [ASHRAE 1991]. In sizing the ductwork for the HVAC system it was assumed that the required air movement is 0.00508 cms/m² (1 cfm/ft²), and that the maximum velocity in primary ducts is 10.16 m/s (2000 ft/min), and 8.13 m/s (1600 ft/min) in secondary

ducts. Maximum air velocity in ductwork is limited by the acceptable noise level. A reduction in air velocity will decrease noise levels. Required duct sizes for selected sections of the HVAC network are shown in Table 5.2. Sections 1 through 6 of the HVAC system are shown on Figure 5.5.

5.3 APPLICATION OF ASSESSMENT CRITERIA

As indicated in Section 4.3, the criteria selected for the assessment of existing precast systems are: *fabrication operations, truck requirements, erection operations, method of service installation, coordination between structural and service trades, service maintenance, service capacity, architectural modification, spatial and functional versatility, and building height versatility*. These criteria are selected because they have a major impact on the efficiency or performance of the building system, and they help identify significant differences between precast structural systems.

A measure is developed for each assessment criterion. This measure allows the precast structural systems to be compared to each other. For example, it was determined that *truck requirements* has a major impact on construction costs. A reasonable measure for this criterion is the number of truck trips required for a precast building. The difference between the number of truck trips required for each structural system is then used to evaluate the transportation efficiency of a particular structural system.

5.3.1 Structural Criteria

Structural criteria are defined as characteristics of the structural floor system which impact the efficiency or performance of the structural system. The structural criteria used for the assessment are *fabrication operations, truck requirements, and erection operations*.

5.3.1.1 Fabrication Operations

For this assessment, the effort required in fabrication is measured by the number of precast pieces which are required for example buildings 1, 2, and 3, and the number of forms required with each precast structural system. The complexity of the forms and form congestion are also considered for some systems.

The first consideration is the number of pieces which must be produced. Example buildings 1, 2, and 3 are used to quantify this aspect of the criterion. To allow for a relative comparison between systems it is assumed that all systems use precast columns. Other structural components are cast-in-place or precast depending on the individual system. As shown in Table 5.3, the number of precast pieces required for each system varies significantly. The Dyna-frame system requires significantly more fabrication effort than the U.S. Conventional system with double tees, the Duotek system, and the Trilposite system.

Many systems are not totally precast and some such as the Trilposite, Filigree, and Prestressed Joist systems are largely cast-in-place. Thus, the number of precast pieces will obviously be lower for these systems. A large percentage of the pieces required are floor units. Thus, systems with larger floor units significantly reduce the total number of pieces required. This is shown with the U.S. Conventional system which can be used with either double tees or hollow-core planks. The system utilizing 3 m (10 ft) wide double tees requires 55% of the pieces

required for the system utilizing 1.2 m (4 ft) wide hollow-core planks. Thus, systems with large floor units reduce fabrication requirements significantly.

A second fabrication consideration is the number of forms which are required for each system. As shown in Table 5.3, the majority of the structural systems require either 3 or 4 forms. The exceptions to this are the Trilposite (2 forms) and Contiframe (5 forms) systems.

In summary, the Dycore and Prestressed Joist systems appear to be the most efficient systems to fabricate. Both systems require a large number of precast pieces but these pieces are simple to fabricate. The number of forms is limited to three. The pieces do not have complex end geometry or problems with form congestion. However, as noted earlier, the Prestressed Joist system involves a large quantity of cast-in-place concrete. On the other hand, the Contiframe system appears to be the most difficult system to fabricate. A large number of forms are required and the pieces have complex end geometry. However, the Contiframe system requires only bolting and grouting in the field.

5.3.1.2 Truck Requirements

This criterion addresses the efficiency with which precast components can be transported to the site, and is measured in terms of the number of truck trips. A standard truck is defined in terms of carrying capacity and maximum load dimensions. The standard truck is one that does not require special permits and meets the following specifications:

Maximum load = 178 kN (20 tons)
Maximum cargo height = 2.4 m (8 ft)
Maximum cargo width = 3.0 to 3.73 m (10 to 12 ft)
Maximum length = 12.2 (40 ft)

In all cases, the factor which limits the number of pieces on the truck is the weight of the pieces, and not the height or width of the pieces. For 15.24 m (50 ft) floor members and multi-story columns, the standard truck length is disregarded with the understanding that a larger truck could be used if proper permits are obtained.

For many of the systems, not enough detailed information was available to accurately calculate the dimensions and weights of the individual members, therefore a total number of truck trips is not given. As shown in Table 5.4, truck requirements for the Prestressed Joist system are significantly less than for the other systems, in part because this system requires extensive cast-in-place concrete, and in part because the utilization of the truck capacity could be maximized since the pieces of this system can be efficiently grouped together to closely approach the maximum load limit. This is difficult with systems which utilize large components. For example, the 7.62 m (25 ft) double tees used with the U.S. Conventional system weigh approximately 52 kN (11,700 lbs) each, allowing three to be accommodated on a standard truck with 21.8 kN (4900 lbs) of capacity remaining. Thus, the double tees use only 88% of the truck capacity. For a different example building the utilization of truck capacity by this system could be much lower. The U.S. Conventional system with hollow-core planks requires about the same number of truck trips as the double tee system. The 7.62 m (25 ft) hollow-core planks weigh approximately 25.4 kN (5700 lbs) each, allowing seven to be accommodated on a standard truck, with 445 kN (100 lbs) of truck capacity remaining. Thus, the hollow-core planks use nearly all the truck capacity, making the system efficient to transport.

5.3.1.3 Erection Operations

A reduction in required field effort reduces erection costs. For the assessment, erection efficiency is measured by the quantity of shoring, field placed reinforcement, and cast-in-place concrete required, and by the number of crane picks required for each system. The quantities associated with each of these field operations will give an indication of the field effort required. Table 5.5 provides an indication of the primary field effort required with each system.

As Table 5.6 shows, many systems require shoring for the beams. Four systems surveyed also require shoring of floor units: Filigree, IMS, Trilposite, and Spanlight. On the other hand, 6 systems eliminate shoring requirements completely: the U.S. Conventional system with hollow-core planks and with double tees, and the Duotek, PD2 Frame, Swedish, and Contiframe systems. These 6 systems are designed to require as little field work as possible. The U.S. Conventional system with hollow-core planks requires no field placed reinforcement, no formwork, and no cast-in-place concrete. The PD2 Frame, Swedish, and Contiframe systems have similar field requirements.

Several systems require extensive field placed reinforcement and cast-in-place concrete: Filigree, Quickfloor, Prestressed Joist, and Trilposite. However, a more important consideration than the quantity of cast-in-place concrete is the need for formwork. Filigree construction and the Quickfloor system eliminate the need for formwork by using precast members as stay-in-place forms. The Prestressed Joist system uses an efficient method to construct formwork for the floor system, but significant effort is required to construct formwork for the beams. The Trilposite system uses cast-in-place beams and requires that openings be provided in the beams making beam formwork difficult to construct.

For example building 1 the average number of crane picks is approximately 625 (Table 5.7a). The Dyna-frame system requires significantly more crane picks (885) than the other systems. The primary reason for this is the narrow floor planks, 0.6 m (2 ft), and the single story columns which are typically used with the system. Crane requirements are minimal for the following systems: the U.S. Conventional system with hollow-core planks, and the Dycore, PD2 Frame, Swedish, Spanlight, and the University of Nebraska systems. These systems all utilize hollow-core planks and since it is assumed that three planks are lifted with each crane pick, the number of crane picks is less than the number of pieces. While lifting 3 pieces at once reduces the number of crane picks, the floor planks still need to be positioned with the aid of the crane. This may slow down erection.

It can be seen from Table 5.7b that an increase in floor span from 7.62 m (25 ft) to 15.24 m (50 ft), results in a fewer number of precast pieces, and a reduction in the number of crane picks by approximately 40%. Thus a significant erection savings is achieved with the four systems that can span the 15.2 m (50 ft) floor spans. A 6% difference exists between the number of crane picks for example buildings 2 and 3. This is the result of fewer structural components required for building 3. The layout of building 3 reduces the number of interior columns and beams.

In terms of erection efficiency it appears that the following three systems are most efficient: the U.S. Conventional system with hollow-core planks, the Swedish system with hollow-core planks, and the Contiframe system. Since cast-in-place concrete is required as a topping for double tee floor members and is not required for hollow-core planks spanning 7.62 m (25 ft), the U.S. Conventional system with hollow-core planks was considered slightly more efficient. The Swedish system is similar to the U.S. Conventional system. The Contiframe system is also efficient to erect, despite the large number of precast pieces associated with the

structural system. With the Contiframe system, all connections are bolted and the geometry of components allows the beams to be positioned quickly.

5.3.2 Service Criteria

Service criteria address the impact of the structural system on the efficiency or performance of the service systems. The following criteria are used for this assessment: *method of service installation, coordination between structural and service trades, service maintenance, and service capacity*. A rating scale based on letter grades is used to measure many of the service criteria. Each letter represents a category. Categories labeled "A" are the most efficient and categories B, C, D, E, F are less efficient. Table 5.8 summarizes the results of this assessment and illustrates the degree to which a system accommodates service systems.

5.3.2.1 Method of Service Installation

This criterion refers to the method which can be employed when installing ductwork and plumbing. The structural system will dictate how ductwork or pipe can be incorporated into the structure. The methods of installation are divided into three general categories and rated from most efficient to least efficient. Method "A" is considered the most efficient while method "C" is considered the least efficient. Each category is described below.

A. The most efficient installation method is considered to be placing ductwork, pipe, or conduit on the precast structural surface and connecting the service components. This method is efficient because the service component is placed in its installed position immediately and does not require additional movement. Thus, HVAC equipment, ductwork, plumbing, and electrical conduit are quick to install and over-head work is eliminated.

B. A method which is also efficient is one that allows sections of the HVAC (e.g., ductwork) or piping to be fabricated and connected on the floor, and then raised into position. This allows many of the connections to be made in a position which is easy to work in. Some over-head work will be necessary once the ductwork is raised into position. This method of installation is possible with systems which provide openings in beams, but is not possible if openings are located in closely spaced ribs.

C. The least efficient method of installation is a system which cannot be fabricated in a position which is easy to work in. Systems with horizontal openings in closely spaced ribs require that short sections of pipe and ductwork be used. Installation would be slow for these systems because of the increase in connections and the amount of over-head work.

As indicated in Table 5.8, the majority of systems suspend the horizontal service systems beneath the precast structural floor system and thus receive a "B" rating. The Duotek system receives a "C" rating since beam openings are only spaced 1.83 m (6 ft) apart. The Swedish system uses beams with rectangular openings for horizontal service systems but receives a "B" rating since their spacing does not hinder installation. The Trilposite system receives a dual rating of "A" and "C". While it is efficient to place the services on the precast floor system and then connect components, it is much more difficult if services must be threaded through closely spaced openings as is the case with the Trilposite system.

5.3.2.2 Coordination Between Structural and Service Trades

This criterion refers to the coordination between structural and service trades required to install service components. Systems which require coordination between structural and service trades will typically lead to time delays and inefficient use of labor. An example where coordination is required is with systems which typically place electrical conduit in the cast-in-place portion of the floor slab. Conduit is placed by the electrical contractor after the precast slab is placed and before the iron worker begins to place reinforcing steel. For most projects, a more efficient system would be one that limits this type of coordination.

The levels of coordination have been divided into three categories described below. Category "A" is considered the most efficient and category "C" is considered the least efficient.

- A. Systems in this category require no coordination between structural and service trades.
- B. Systems in this category only require coordination between structural and service trades if electrical conduit is placed in the cast-in-place portion of the floor system, or within hollow-core planks.
- C. Systems in this category require coordination between structural and service trades for placement of HVAC equipment, ductwork, plumbing, or electrical conduit.

As shown in Table 5.8 the majority of systems require little or no coordination between structural and service trades and receive an "A" rating. The following systems typically accommodate electrical conduit in the cast-in-place floor slab and receive a "B" rating: Dycore, Filigree, Prestressed Joist, and Quickfloor. The Swedish system was also given a "B" rating for coordination because the cores of hollow-core planks are often used for electrical conduit, requiring coordination between the precast erector and the electrical contractor. Systems which received a "B" rating are actually more flexible in terms of where services can be placed than systems receiving an "A" rating. However, placing services in the cast-in-place portion of the structural floor system does require more coordination than simply suspending the services beneath the structural floor system.

Two systems received a "C" rating indicating that extensive coordination is required. The Trilposite system obviously requires coordination since the horizontal service systems are placed within the structural floor system. The University of Nebraska system also requires coordination if the beam void is used to house electrical or HVAC components. Both structural systems require coordination between service contractors, iron workers, and the laborers positioning precast members and placing concrete.

5.3.2.3 Service Maintenance

This criterion addresses the ease with which services can be accessed for maintenance. In most situations, the access of the service systems is ultimately a function of the degree of integration with the structural system. In general, the greater the level of integration the more difficult the services are to maintain or replace.

For evaluation purposes, accessibility is defined by six categories. Category "A" identifies a precast system which allows for easy access to services, while category "F" indicates a precast system which provides no access to services.

- A. Services are suspended beneath the structural floor system and unrestricted access to the services is possible.
- B. Services are free to move parallel to the main girders with no restrictions, but when moving perpendicular to them, must pass through openings provided in the beams at a limited number of locations. This arrangement, though similar to the type A arrangement in terms of accessibility from below, does not get the same rating due to the congestion of services that may arise as a result of the limitations on movement in a direction perpendicular to the beams.
- C. Services are positioned between floor units. This arrangement applies to ribbed floor systems (e.g., double tee floor systems or joists) and confines lateral access.
- D. Services pass through openings which are provided in both the floor units and the beams. The degree to which access is restricted at these openings, is a function of the size of the openings provided and the size of the services which are being passed through.
- E. Services are encased within the structural floor system with access in only a limited number of places (e.g., access panels).
- F. Services are encased in the floor system with essentially no access.

As shown in Table 5.8, the majority of precast systems incorporate services in a manner which allows for easy access. The Trilposite and University of Nebraska systems both provide limited access to services which are encased in the floor system. However, both systems encase only low-maintenance services. For example, the Trilposite system uses the encased zone for supply ductwork, a return air plenum, and for electrical services. The University of Nebraska system encases an air supply plenum and electrical components. In both systems plumbing would be positioned beneath the floor system to allow for maintenance.

5.3.2.4 Service Capacity

This criterion refers to those precast structural floor systems which limit the capacity of the HVAC system, because of space restrictions. Limits on the capacity of the HVAC system are possible with systems which use floor unit and beam openings to accommodate secondary ductwork. Only the Duotek, TrilPOSITE, and Swedish systems limit duct size, and thus may limit the HVAC capacity.

The Duotek system uses 712 x 356 mm (28 x 14 in.) beam openings. As Table 5.2 indicates, it is not practical to pass primary ductwork (HVAC section 1) through beam openings. However, the openings provided by the Duotek system accommodate the secondary HVAC ductwork of example building 1. It should be noted that example building 1 is small in plan and the duct requirements for this building are minimal. More serious problems would arise with a building which is larger in plan.

The Trilposite system uses 200 x 250 mm (8 x 10 in.) tee stem openings. As shown in Table 5.2 these openings do not accommodate the secondary HVAC duct requirements of example building 1. With openings of this size, supply ducts need to be divided into smaller ducts to achieve the desired capacity. This will reduce installation efficiency and increase material costs.

Information was not available on the size of the beam openings in the Swedish system.

5.3.3 Architectural Criteria

Architectural criteria address the impact of the structural system on the efficiency or performance of the architectural system of the building. The following architectural criteria are used for the assessment: *architectural modification*, *spatial and functional versatility*, and *building height versatility*.

5.3.3.1 Architectural Modification

This criterion addresses the efficiency of modifying the structural floor system to accommodate a large vertical opening. The ability to accommodate a 3.66 x 2.41 m (14 x 8 ft) vertical shaft for a stairway is investigated.

The Prestressed Joist system best accommodates an opening of this size. Framing can be constructed around the opening and gravity loads can be transferred to adjacent joists. With this system, stringers can easily be framed between joists. Filigree construction can also accommodate large vertical openings.

The systems that use hollow-core planks and double tees do not easily accommodate an opening of this size. Two hollow-core planks and one double-tee would need to be removed or cut. This is easier with hollow-core floor systems. The problem arises in framing around the opening. The hollow-core planks and double tees surrounding the opening may not accommodate the additional load. Therefore vertical support from additional columns or load bearing walls may be required.

It would be very difficult to modify the IMS system for an opening of this size. The post-tensioned floor units would limit the possible location of this opening, and due to the small floor units, it may not be possible to fit the opening within one unit.

5.3.3.2 Spatial and Functional Versatility

This criterion addresses the spans that can be achieved with a structural system, the ability of the structural system to accommodate large vertical openings, and the ability of the structural system to accommodate non-rectilinear spaces. Large vertical openings were considered earlier by the *architectural modification* criterion, and a measure for the ability to accommodate non-rectilinear spaces was not developed, thus the *spatial and functional versatility* criterion is measured by the range of beam and floor unit spans which can be achieved. For office loads it was assumed that conventional hollow-core planks have a practical span range of 4.6 to 10.7 m (15 to 35 ft), and that conventional double tees have a practical span range of 6.1 to 18.3 m (20 to 60 ft).

A typical office building requirement is 9.1 m (30 ft) square bays. As shown in Table 5.9, all but 4 of the systems can achieve this requirement. While Filigree construction can be used for long spans, it is predominantly used for shorter spans. The exception to this is parking garage construction where it has been used for spans longer than 9.1 m (30 ft). The IMS, Structurapid, and Trilposite systems have all been developed for spans of less than 9.1 m (30 ft) and would need to be modified for large spans.

The following systems can achieve relatively long spans: the U.S. Conventional, Duotek, Dyna-frame, PD2 Frame, Prestressed Joist, Swedish, and Thomas systems. Maximum floor spans for systems using double tees is approximately 18.3 m (60 ft). These spans would require an excessive depth. Maximum beam spans are approximately 12.2 m (40 ft).

5.3.3.3 Building Height Versatility

This criterion addresses the impact of the structural system on the building height. Floor-to-floor height is a function of the depth required for the structural system coupled with the depth required for horizontal service systems.

Total floor depth is shown in Table 5.10. The total depth of the floor system is based on the structural depth required and the depth required for HVAC ductwork. It is assumed that an additional 200 mm (8 in.) depth is required for electrical, and plumbing service systems. The depth of the floor system is calculated for three regions in the example buildings. The deepest floor system is in the central corridor region and is governed by the structural depth plus the depth required for HVAC section 1 (Figure 5.5). It is assumed that the ceiling can be dropped in this region. The ductwork for the perimeter zones is positioned at the perimeter of the building, and it is assumed that the ceiling can be dropped in this region. Total floor depth for the perimeter region is a function of structural depth plus the depth required for HVAC section 6. It is assumed that the remainder of the floor system has the same depth. Total floor depth for the interior region is a function of structural depth plus the depth required for HVAC section 5.

For the 7.62 m (25 ft) square bays of example building 1, Table 5.10 shows that the University of Nebraska and Dycore systems have a significantly more shallow structural depth than the other systems. The Duotek system is deeper than the other systems, with a structural depth of 1016 mm (40 in.). However, the Duotek system spans far more than 7.62 m (25 ft) with this structural depth.

The deepest portion of most floor systems is the central corridor where primary ductwork is located and where it is often feasible to drop the ceiling. The Dyna-frame system enables primary ductwork to pass between girders rather than beneath them, thus reducing total floor depth. As Table 5.10 indicates, the total floor depth of the Dyna-frame system is the same in the corridor and interior region of the building. For most other systems the corridor is approximately 380 mm (15 in.) deeper than the interior region of the building.

Floor-to-floor height is a minimum for the Dycore and University of Nebraska systems. For example building 1, both systems have a total floor depth of 711 mm (28 in.). The Duotek system is more competitive at longer spans.

5.4 ASSESSMENT OF SYSTEMS

Of the 19 precast systems described Chapter 3, 16 are assessed in this section using the criteria in section 4.3 and the tables presented in Section 5.3. For each system the assessment is divided into three categories: Structural, Service, and Architectural.

The aim of the assessment is to provide insight into the advantages and disadvantages of each precast system and to identify the limitations of each system. This objective is facilitated by comparing each system relative with the other 15 systems included in the assessment. Example buildings 1, 2, and 3 are used to quantify relative differences between systems.

5.4.1 U.S. Conventional System

Structural Differences exist between a conventional system which uses hollow-core floor units and one which uses double tee floor units. Cost data provided by Means indicates that for floor spans of less than 9.14 m (30 ft), hollow-core planks are significantly more economical to manufacture and erect. A 9.14 m (30 ft) span hollow-core plank costs \$6.13 per sq. ft, and a double-tee of an equivalent span costs \$9.24 per sq. ft [Means 1992]. This difference in cost is a result of additional material costs.

While material costs differed greatly, erection costs are only slightly higher for the double tee floor system. This is despite the fact that double tees reduce the number of precast floor units required. As indicated in Table 5.3, the system with hollow-core planks requires 480 more precast pieces for example building 1 than the conventional system with double tees. This difference can be attributed to the fact that a standard hollow-core plank is 1.2 m (4 ft) in width, and a standard double tee is 3 m (10 ft) in width. Erection savings result because the number of crane picks is actually less for the hollow-core plank system because three planks are lifted with each crane pick, where typically only one double tee is lifted per crane pick.

The difference in the number of pieces does not significantly impact the number of truck trips required. While a standard truck accommodates three 457 mm (18 in.) deep double tees, the same truck accommodates seven hollow-core planks of the same length.

In terms of erection operations, the conventional system is very efficient. The system requires a minimal number of crane picks, and does not need field shoring and field placed reinforcement. If double tees are utilized for flooring, then cast-in-place concrete is required but formwork does not need to be constructed. The system does require welded connections. Research by Martin and Korkosz [1982] includes an evaluation of typical precast connections. Their research indicates that the welded beam-to-column connection (Figure 3.1) which is typically used with the conventional system is a good connection that allows quick and easy erection.

Service The conventional system uses a traditional approach to accommodate horizontal service systems, suspending electrical conduit, plumbing, and HVAC components beneath the precast floor system. As shown in Table 5.8, both the hollow-core floor system and the double tee floor system rate well in terms of service criteria, with the hollow-core system performing slightly better. The difference arises if cavities between tee stems are utilized. Installation of services is unrestricted, unless the cavities between tee stems are used to accommodate ductwork or HVAC equipment. This limits the space provided for installation, hence a category "B" rating for this system. Services positioned between tee stems also limits the accessibility for maintenance. The amount that maintenance or installation is hindered depends on the size of the service equipment and the distance between the tee stems.

Architectural A major advantage of the U.S. Conventional system is that it can meet requirements for large column free open spaces. A typical inverted tee beam can span to 12.2 m (40 ft), where many of the other systems surveyed have span limits of 10 m (32.8 ft) or less. While the hollow-core plank is limited to spans of less than 10.7 m (35 ft), double tees can span 18.3 m (60 ft). Thus if a 15.2 m (50 ft.) floor span is required, as with example buildings 2 and 3, then the double tee can easily meet this requirement.

Although the ability to meet space requirements is an important criterion, building height versatility is also important. As indicated in Table 5.10, the structural floor depth for example

building 1 is less with hollow-core planks than with double tees. The difference in depth is because for the 7.62 m (25 ft) span the weight of the double tee is slightly greater than the weight of the hollow-core plank, hence a deeper beam is required. This will differ for floor spans over 9.14 m (30 ft). In comparison to the other systems, this floor depth is slightly above the average depth of 645 mm (25.4 in.).

The total floor depth for example building 1 is 864 mm (34 in.) for a system with hollow-core planks, and 965 mm (38 in.) for a system with double tees. This excludes the floor depth of the central corridor and the perimeter. The difference in depth is attributed to both the layout of the HVAC system for example building 1, and the difference in depth between the hollow-core planks and double tees (the depth of double tees are 457 mm (18 in.) and the depth of the hollow-core planks are 305 mm (12 in.)). The depth of the interior portion of the floor system was controlled by the depth requirements at section 5 of the HVAC system. Since tee stems pass transverse with respect to this ductwork, cavities between tee stems could not be utilized to reduce floor depth.

Relative to the other precast systems surveyed, the total floor depth of the U.S. Conventional system with double tees is above the average total floor depth. The depth required for the U.S. Conventional system with hollow-core planks is less than the average total floor depth for example building 1.

5.4.2 Duotek System

Structural The Duotek system is similar in many respects to the U.S. Conventional system with double tee floor units. The primary difference is that openings are provided in tee stems and in precast inverted tee beams to allow for the passage of services. To create these openings, blockouts are required. This increases fabrication costs, but the cost increase is not too great since the openings are on a set module, and thus it is practical to construct a form which can accommodate the required openings. Material and labor costs are also increased by the additional reinforcement required around the opening.

As shown in Tables 5.3, 5.4, 5.6, and 5.7 the Duotek system is efficient to fabricate, transport, and erect. The Duotek system requires the fewest precast pieces of the 16 systems in the assessment, because it uses 3.66 m (12 ft) wide double tee floor members. This results in less handling in the fabrication plant, fewer truck trips, and less crane picks.

Service As Table 5.8 indicates, the Duotek system rated poorly when evaluated with service criteria. In threading HVAC ductwork and plumbing through horizontal openings, problems arise with both installation and maintenance. Installation is hindered since the tee stems are closely spaced. Shorter segments of pipe or ductwork are required, increasing the number of connections, and increasing installation costs. Installation is also hindered because pipes are not connected on the floor where it is easy to work, but are connected in place (over-head) where it is more difficult. Thus a "C" rating for *method of service installation*. An additional drawback of this precast floor system is access to services for maintenance. The amount of space provided is a function of the distance between the tee stems and the size of the service equipment.

The aim of the openings is to accommodate all the service components (ductwork, plumbing, and electrical), but this is not possible due to the size of ductwork required in office buildings. The size of openings with the Duotek system are 711 x 356 mm (28 x 14 in.). Table 5.2 shows that openings of this size can accommodate secondary ductwork. Openings of this size may limit the capacity of the HVAC system and limit the ability to upgrade or expand air

handling capacity. The system would be more effective if the openings for electrical and plumbing services were placed at a different depth than the openings for HVAC ductwork. This would allow different service systems to pass each other transversely.

Architectural The Duotek system is capable of large column free spans. Inverted tee beams can span 9.1 m (30 ft) and double tee floor units can span 18.3 m (60 ft). While the openings in the inverted tee beams reduce the allowable beam spans, the open space provided is sufficient for office requirements.

The primary drawback of the Duotek floor system is the floor depth which is required with the system. The floor system was developed to reduce floor-to-floor height but this can only be achieved if all the services can be housed within the openings provided in beams and floor units. This system is better suited for long spans, and was not well-suited for the 7.62 m (25 ft) spans of example building 1.

5.4.3 Dycore System

Structural A major advantage of the Dycore system is the ease with which precast components of the system can be fabricated. The system requires only three forms, because soffit beams are manufactured as solid Dycore planks. Since the precast components of the Dycore system do not require the insertion of steel plates for connections, casting is very efficient. Multi-story columns require blockouts at the beam level, but this is relatively easy to accomplish in the precast plant.

The number of precast pieces required for the system, 1053, is above the average number of 1015 required to construct example building 1. This is due to the large number of 1.2 m (4 ft) wide Dycore floor planks required to construct the floor system of example building 1. As shown in Table 5.4, the impact of the large number of pieces is reflected in the large number of truck trips required (270).

The system requires a significant amount of field labor relative to the other systems surveyed. As indicated in Table 5.6, shoring and some formwork are required to accommodate cast-in-place concrete. An additional required field operation is the placement of steel reinforcing. While many different skills are required in the field, possibly resulting in coordination problems, the quantity of work is limited. For example, the Dycore system requires shoring of the beam members, but not the floor units. Cast-in-place concrete is required only for soffit beams.

An additional advantage to the system is the elimination of welded connections. This is advantageous in geographic locations where cast-in-place connections are more economical than welded connections.

Service As described in Chapter 3, horizontal service systems are typically suspended beneath the precast floor system. The exception to this is electrical conduit which can be placed transversely on the precast soffit beam. This will enable the cores of hollow-core planks to be utilized for electrical runs. The primary drawback with this is the coordination required between the erector and the electrical contractor, since the electrical conduit is placed before the negative moment steel reinforcement and cast-in-place concrete is placed. An alternate solution is to suspend the electrical conduit beneath the floor system along with the HVAC ductwork, and horizontal plumbing runs. This solution provides for easy installation and maintenance of the services.

Architectural While this system cannot achieve long spans, the system can be used in buildings where large column free open spaces are required. The system is capable of 10.7 m (35 ft) square bays under office loads. The system is also very shallow, requiring a 508 mm (20 in.) structural floor depth for example building 1. This shallow depth is due to the use of high strength concrete for precast beams and floor units. When horizontal service systems are considered, the total floor depth required is 711 mm (28 in.). This shallow depth is due to the Dycore planks which are only 203 mm (8 in) deep compared with a conventional hollow-core plank which are 305 mm (12 in.) deep for the same span. The 711 mm (28 in.) floor depth is the minimum depth required for any system included in the assessment.

5.4.4 Dyna-frame System

Structural Fabrication requirements for the Dyna-frame system are significant. For example building 1, a total of 1952 pieces must be manufactured. The majority of these pieces are hollow-core planks, but the single story columns also add to this total. The large number of pieces increases handling requirements, both during fabrication and erection. For erection the system requires more crane picks (885) than any other system. With crane costs being a significant portion of erection costs, the system is relatively expensive to erect. However, erection costs of the building are reduced by the connections which are simple to construct.

The single story precast columns of the system are cast with a structural steel tube at the center for the connections. This is efficient for Flexicore Systems to produce, but the system requires additional effort for precast manufacturers who are not accustomed to this connection and the tolerances associated with it. The extra work in the fabrication plant reduces the time and effort required for connections in the field. The connections enable quick and easy erection and provide construction stability. The system does require shoring, field placed reinforcing, and cast-in-place concrete for soffit beams.

Service The Dyna-frame system uses cantilevered beams to provide space for services. This provides the opportunity for a reduced floor-to-floor height for some buildings. The advantages of the system include easy installation of services, and elimination of coordination requirements between structural and service trades. Thus the system has a rating of "B" for *method of service installation* and a rating of "A" for *coordination between structural and service trades* (Table 5.8). A potential drawback of the system is congestion problems in the area where the services must pass between beams, thus a "B" rating for *service maintenance*. If all horizontal service systems are required to fit in a small area, congestion may cause a decrease in space for installation or accessibility for maintenance. The impact of this method of incorporating services on total floor depth is discussed in the Architectural section.

Architectural The Dyna-frame system is capable of fairly large beam spans, thus providing large column free areas. Flexicore floor planks can span 10.7 m (35 ft) under office loads. The rectangular soffit beam can span 12.2 m (40 ft).

The floor-to-floor height required with this system is dependent on the layout of the HVAC system. The precast cantilevered beams provide an excellent opening for services. In example building 1, this opening is above the corridor. Thus the total depth of the floor system in the corridor region is only 914 mm (36 in.). This is the shallowest depth for any of the 16 systems, making the Dyna-frame system ideal for buildings where a drop-ceiling is not desired in the corridor region. The total floor depth required for the interior space is above the average.

5.4.5 Filigree Wideslab System

Structural Filigree construction can be classified as either precast or cast-in-place construction. The system often uses precast Filigree floor planks with a cast-in-place composite floor slab, and cast-in-place beams, and columns. An alternative is the Filigree floor planks with a cast-in-place floor slab and precast soffit beams and single story columns. The latter system is used for the assessment.

Fabrication of floor planks is project specific, but is a very efficient process. Vertical openings in the planks are accommodated during casting, limiting the quantity of openings which must be cut in the field. The planks are easy to fabricate and the light steel truss which protrudes from the top of the precast plank facilitate handling and does not hinder transportation.

As shown in Table 5.6, a large amount of field work is required with this system. Shoring is required beneath both beams and flooring units. This is a significant expense to a contractor who is not outfitted with the quantity of shoring required for a multi-story structure.

While the system may not be competitive in regions where field labor is expensive, it does compete with cast-in-place systems because the system requires less field work than a cast-in-place system. A major advantage of this system over cast-in-place systems is the elimination of formwork, since the precast Filigree slabs and soffit beams act as stay-in-place forms.

Service Filigree construction enables electrical conduit to be placed in the cast-in-place portion of the floor slab. As indicated in Table 5.8, if this option is chosen, the required coordination in the field may hinder construction of the floor system. Thus, the system is given a "B" rating for *coordination between structural and service trades*. An alternative is to suspend all services beneath the precast system. This is efficient in terms of installation, coordination, and accessibility.

Architectural Filigree construction has been used for office buildings, however, this use has been limited. With office loads, Filigree slabs can span 9.1 m (30 ft), and beams can span 7.6 m (25 ft). Thus the system is not as versatile as many of the systems surveyed. Longer spans may be achieved, however, if blockouts are provided within the beams and floor units to reduce the weight of structural floor system. Filigree construction can accommodate unplanned vertical openings.

5.4.6 IMS System

Structural Fabrication of IMS floor units is a two stage casting process. Although this provides for a structurally efficient precast component it does require the precast plant to perform additional tasks. Precast floor components are manufactured in standard sizes, limiting the system versatility but improving the efficiency of fabrication. Floor members are relatively large in terms of floor area covered, and this reduces the number of pieces required to construct example building 1. As shown in Table 5.7, only 698 crane picks are required for example building 1, which is relatively few compared to the other systems.

A potential drawback with the IMS system is the post-tensioning requirement. The impact of post-tensioning on erection will depend on the availability of labor and the field conditions. Post-tensioning offers advantages in structural performance which make the system desirable in many applications, despite the initial erection costs.

Another erection consideration is that steel angles are attached to columns, eliminating the need for extensive field shoring. Only a small quantity of grout or cast-in-place concrete is required for connections between floor units.

Service Services are accommodated beneath the structural floor system. As shown in Table 5.8, the result is ease of installation and maintenance. No coordination between structural and service trades is required.

Since the precast structural system has a constant depth, services are not placed between concrete components. The constant structural depth allows for more flexibility in arranging ductwork and pipe.

Architectural The IMS system was not originally designed for long span applications and as a result the versatility of the system is limited. Floor components are manufactured for a maximum span of 7.2 m (24 ft). Maximum beam spans are also approximately 7.2 m (24 ft). However, the system could be modified to accommodate longer spans.

It appears that the structural floor system is shallow relative to other floor systems in the assessment. In addition, the total floor depth is also shallow, because the elimination of beams enables the shallow depth of the floor units to govern the total floor depth.

5.4.7 PD2 Frame System

Structural Components of the PD2 Frame system are difficult to fabricate in comparison to precast components of other systems. Floor planks require complex formwork at the ends and shear keys that are difficult to cast. Both beams and columns require steel plates to be inserted in the form before casting. This could result in congestion problems. Additional congestion problems result if beams are notched at the column-to-beam connection since this requires additional reinforcement.

An advantage of the system is that it provides for quick erection. As shown in Table 5.7, the number of crane picks is the fewest for any system in the assessment. Erection is facilitated by steel plates cast into the columns and beams. The plates are bolted during erection and provide stability so construction can continue before the connection is completed. Other advantages during erection are that shoring is not required, and that a very small quantity of reinforcement is required.

As is typical with many European systems, no welding is required. Grout is used to provide both connection strength and protection. This may be advantageous in some areas.

Service All horizontal service systems are suspended beneath the precast floor system, but beams are notched at areas adjacent to the column to allow services to pass under the beams without increasing total floor depth. The typical notch is 350 mm (14 in.) long and 100 mm (4 in.) deep. This is too small for ductwork, but can be used for electrical conduit or plumbing. As indicated in Table 5.8, the floor system is efficient in accommodating services.

Architectural While the PD2 Frame system is based on a set module, it does provide for versatility, since the 0.3 m (1 ft) module is relatively small. The maximum floor span which can be achieved is approximately 10.7 m (35 ft), with maximum beam spans of 12.2 m (40 ft). *Building height versatility* is limited by a maximum building height of 4 stories.

The structural depth of the precast floor system, 650 mm (25.5 in.), is controlled by precast inverted tee beams. The total floor depth including services is calculated to be 853 mm (33.5 in.). With other systems, 203 mm (8 in.) was required for services, but the notched beams of this system allow for a 100 mm (4 in.) reduction in this depth. As a result, the total floor depth for the PD2 Frame system is slightly less than the average total floor depth.

5.4.8 Prestressed Joist System

Structural The Prestressed Joist system is a combination of cast-in-place and precast concrete. The system is efficient to fabricate because of the simple precast components which are utilized. Precast joists are manufactured in a number of standard dimensions, and soffit beams are available in two sizes. Form congestion is not a problem.

As indicated in Table 5.3, the number of pieces required is relatively high in comparison to other systems. Seventy percent of these precast components are prestressed joists. These joists are easy to handle in the precast plant and efficient to transport. As shown in Table 5.4, less than 100 truck trips are required for example building 1.

The system does require a significant amount of field work, but many of the labor intensive requirements have been simplified. Shoring is required to support precast soffit beams, but not floor joists. Formwork for the floor is supported by steel angles which easily attach to floor joists making construction of this formwork an efficient process. However, complex formwork for the cast-in-place portion of soffit beams must be constructed. A major requirement in the field is reinforcement which is required for both the floor slab and the composite soffit beam. An additional consideration is the large quantity of cast-in-place concrete which is required.

Service The system provides the opportunity for electrical conduit and junction boxes to be placed in the cast-in-place portion of the floor slab. As with Filigree construction, this may pose coordination problems between structural and non-structural trades, and hence the "B" rating shown in Table 5.8 for *coordination between structural and service trades*.

A major advantage with the system is the ease with which vertical openings can be accommodated. Openings are simply blocked-out in the field and additional reinforcement is provided around the opening. The width of an opening is usually limited by joist spacing.

If ductwork and plumbing are suspended beneath the concrete floor system, installation and maintenance efficiency will depend on the joist spacing.

Architectural Relative to other precast systems, this system is very versatile. Under office loads, the joists can span 15.2 m (50 ft), and composite soffit beams can span 12.2 m (40 ft). Joist spacing can be decreased if a reduction in floor depth is required. For office loads and a 7.62 m (25 ft) floor span, the joist spacing can range from 0.76 m (2.5 ft) to 2.6 m (8.5 ft). Large column-free spaces can be achieved. This system was able to meet the 15.2 m (50) floor span required for example buildings 2, and 3.

As shown in Table 5.10, the structural floor depth is less than the average structural floor depth of the systems in the assessment.

5.4.9 Quickfloor System

Structural A major advantage of the Quickfloor system is that both precast beams and floor units can be mass produced using machinery. This results in efficient fabrication. As shown in Table 5.3, only three forms are required with the system, and beams can be produced on either a 1.2 m (4 ft) or a 2.4 m (8 ft) casting bed. If production uses a 2.4 m (8 ft) bed, then two 1.2 m (4 ft) beams can be produced simultaneously.

As shown in Table 5.6, the system requires a significant amount of field effort. Shoring is required for temporary support of beam members. The soffit beams require field placed reinforcement, and a relatively large quantity of cast-in-place concrete is required. A major advantage of the system over cast-in-place systems is that the precast components act as stay-in-place forms.

Service Electrical conduit can be placed in the cast-in-place portion of the floor system and/or within the hollow-core floor planks. As with other systems which use the cast-in-place portion of the floor for services, a potential drawback is coordination between structural and service trades. All plumbing and HVAC components are placed beneath the precast floor system.

Architectural The Quickfloor system can achieve floor spans and beam spans to 10.0 m (32.8 ft). Relative to the other precast systems, the Quickfloor system is less versatile in terms of span length. However, the system is efficient in terms of building height versatility. As shown in Table 5.10, the structural floor depth required for example building 1 is 560 mm (22 in.). This is significantly less than the average structural floor depth of 645 mm (25.4).

5.4.10 Structurapid System

Structural Complex end geometry, form congestion, and the large number of pieces decrease fabrication efficiency for the Structurapid system. Beams are tapered at their ends to facilitate the beam-to-column connection. This requires extra forming and also additional reinforcement in this region. The column is a hollow tube. This is difficult to cast and handle since the walls of the column are relatively thin. Extra forming is also required at column ends to facilitate the tongue and groove connection.

As indicated in Table 5.7a, a large number of pieces is required with the system. This is due to single story columns and the use of hollow-core floor planks. The large number of pieces impacts handling requirements both in fabrication and erection of the structure.

An advantage of the system is that quick erection is possible due to the connection configuration. The slotted column end provides an excellent cavity for the beam to drop into. Beam-to-column connections are easily constructed, using a prefabricated reinforcement cage and the hollow column as formwork for cast-in-place concrete. The drawback with using cast-in-place concrete for the connection is that stability of the structure must be provided until the concrete gains adequate strength.

Service Horizontal service systems are suspended beneath the precast floor system. As Table 5.8 indicates, service efficiency and performance are good.

Architectural The system has limited spatial and functional versatility. The major drawback of the structural system is its inability to achieve long spans. The maximum span for both floor

units and beams under light live loads is 7.6 m (25 ft). The system is not suited for office buildings. Modifications are needed for the beams, the columns, and the column-to-beam connection for the system to achieve longer spans. An additional limitation of the system is that it is designed for structures of 5 stories or less.

5.4.11 Swedish System

Structural Fabrication is efficient with the Swedish system. Precast components are manufactured in several standard dimensions minimizing the total number of forms a precast manufacturer is required to construct. Components are simple in geometry with required blockouts being the only aspect which needs to be considered. Only two or three blockouts are required in beams and this can be accommodated easily in the precast plant. Additional reinforcement is required in this region and form congestion may be a problem.

As shown in Table 5.6, the system is efficient to erect, minimizing the field effort required. The system eliminates the need for shoring, field placed reinforcement, and cast-in-place concrete. Connections are similar to that used for the U.S conventional system.

Service Similar to the Duotek system, the Swedish system provides blockouts in beam members to pass plumbing and ductwork through without increasing the total floor depth.

The system utilizes two types of floor units: hollow-core planks and double tees. The hollow-core system is the one considered here. With hollow-core planks, the cores are utilized for electrical distribution. The cores of each plank, which are supported on precast rectangular beams, are lined up longitudinally forming a straight run for electrical conduit. While this is effective for the electrical systems, this method of installation does require coordination between structural and service trades.

Installation of services is not affected by the beam openings, since large sections of ductwork can be fabricated on the floor and then threaded through the openings. As shown in Table 5.8, *maintenance of services* is efficient since widely spaced openings do not hinder access.

Architectural The system is sufficiently versatile for many types of structures since it can be used with both hollow-core planks and double tees. The system can achieve beam spans of 12.2 m (40 ft), and floor unit spans of 12.2 m (40 ft). Structural depth is 711 mm (28 in.) and total floor depth at the interior of the structure is 914 mm (36 in.). This depth is more than the average total floor depth required for example building 1, but it could be reduced if plumbing and electrical were also passed through the beam member.

5.4.12 Thomas System

Structural As shown in Table 5.3, the Thomas system is fairly efficient to fabricate. Since 2.4 m (8 ft) wide double tee floor units were used in the example buildings, the number of pieces required (653) is relatively small. Columns with more than two corbels are required, increasing the fabrication effort.

Erection of the system does require a significant amount of field labor. Cast-in-place concrete is required for beam members and Dywidag bars are bolted to the column to provide a mechanical connection between the column and the beam. This eliminates the need for welding between the column and the beam. Field shoring is required for the beam but formwork is eliminated.

Service The location of the horizontal service systems between the tee stems limits the access for maintenance hence the "C" rating for *service maintenance* shown in Table 5.8. The amount that installation and maintenance is hindered is a function of the size of the service equipment and the distance between the tee stems.

Architectural A major advantage of this system is its ability to provide large column free spaces. The double tees used for floor units can span 18.3 m (60 ft), and the beams can span over 9.1 m (30 ft). Though large spans can be achieved, the floor system is deep relative to the other systems in the assessment. This is due to both the depth of the double tees and the depth of the U shaped precast beams.

5.4.13 Trilposite System

Structural The Trilposite system can be considered as a cast-in-place system or a precast system. While columns and floor units are precast, beams are cast-in-place and a cast-in-place topping is required for the floor slab. While only two forms are required with the system, some aspects of the fabrication process need to be considered. The system utilizes floor units which are similar to inverted double tees. These units are cast as shallow double tees and then rotated to their final position. This is a problem for precast plants which do not use a rotating table. These floor units also require a series of 200 mm x 250 mm (8 in. x 10 in.) openings in the tee stems. This requires a blackout during casting and an increase in steel around these openings. The large number of openings and their close proximity leads to form congestion. Placement and alignment of these blockouts and reinforcement will be costly.

Openings are also required in the cast-in-place beams. Thus, the same problems will arise in the field, and will have a major impact on erection costs. Another major disadvantage with the system is the large number of erection operations which are required. As indicated in Table 5.6, formwork must be constructed for beams, and shoring, reinforcement, and cast-in-place concrete is required. In addition since beams and connections are cast-in-place, construction of upper stories is delayed until the lower stories have reached adequate strength.

Service This Trilposite system provides the opportunity for horizontal service systems to be encased within the concrete floor system. As shown in Table 5.8, this is not practical for office buildings. Installation of ductwork is not feasible with this system because the ductwork simply does not fit into the space provided. While the precast floor unit provides an excellent working surface, the ductwork must be threaded through 200 mm x 250 mm (8 in. x 10 in.) oval openings.

The size of these openings also limits the capacity of the HVAC system. The area provided by one opening is approximately 51,600 sq. mm (80 sq. in.). As shown in Table 5.2, this does not accommodate the duct areas required for example building 1.

Since the space provided in the floor system is inaccessible for maintenance, it should not be used for air supply or for plumbing. However, the space is useful as a return air plenum and for the electrical system, since the required access for maintenance is minimal for these services. If this space is used for the electrical system then coordination between structural and service trades is required. Electrical conduit must be placed before the topping slab is cast. Thus, the system is given a "C" rating for *coordination between structural and service trades*.

Architectural Originally designed for school and residential construction, the Trilposite system does not meet the requirements of office building construction. The versatility of the system is limited. The system has a maximum beam span of 6.1 m (20 ft), and the floor units can span 10.7 m (35 ft). The system could be modified to accommodate longer beam spans but the beam depth would need to be significantly increased.

5.4.14 Contiframe System

Structural The Contiframe system is entirely precast. As shown in Table 5.3, the Contiframe system requires more fabrication effort than the other systems. This is attributed to the number of forms required, the complex end geometry of the components, and the amount of inserts required in forms. As indicated in Table 5.3, the system requires 5 separate forms to be constructed. While the fabrication of the hollow-core floor planks is efficient, fabrication of the beams and columns is inefficient. Three different beam components are required: standard beams, in-fill beams, and corner pieces. The end geometry of each of these components is complex and thus increases the cost of constructing the form. Additional fabrication costs result from congestion in the form. Since, components are connected with bolted steel plates, additional reinforcement, and steel reinforcement are required at the ends.

While the structural system requires a significant fabrication effort, the system is quick and easy to erect. As shown in Table 5.6, erection effort is minimal. An additional advantage is that the bolted connections of the system provide stability during erection.

Service Services are suspended beneath the precast floor system. As Table 5.8 indicates, this results in services which are easy to install and access for maintenance. The impact of services on total floor depth is commented on in the Architectural section.

Architectural The Contiframe system is designed for medium spans, and not for the relatively long spans required of some office structures. However, the structural system can achieve beam spans of 9.1 m (30 ft), and floor spans of 9.1 m (30 ft).

As shown in Table 5.10, the structural floor depth required for example building 1 is slightly more than the average. Total floor depth is slightly less than average.

5.4.15 Spanlight System

Structural The Spanlight system requires significant labor to fabricate and erect the structural system. Fabrication considerations include complex form geometry, a large number of pieces, and form congestion created by reinforcement. The beam component is trough shaped and is cast up side down and then turned-over after casting is complete. This is a problem for plants which do not have a rotating table. Fabrication problems may arise with the multi-story precast column component. The column requires a blackout at the beam level. Post-tensioning cables will pass through the column in this region requiring additional column reinforcement. The result is form congestion which increases fabrication time and costs.

The large number of pieces associated with the system is attributed to the relatively small floor units which are used. Although this increases handling requirements both in the precast plant and in the field, fabrication of these components is very efficient since they are modular.

A potential drawback with the Spanlight system is the post-tensioning requirement. A large quantity of cast-in-place concrete is also required but formwork is not needed since the precast beam serves as a stay-in-place form. Since post-tensioning is utilized, a temporary steel collar is attached to the column at the beam level to support the beam during erection. Since no intermediate shoring is required, this is a very efficient process when compared with conventional shoring methods.

Service The developer of the Spanlight system indicated that a system with openings in members for services to pass through is inefficient, because of the increase in construction time required. Hence, the system was designed to be as shallow as possible so that services could be suspended beneath the precast floor system. As shown in Table 5.8, the accommodation of services in this manner is very efficient. Services can be easily installed from beneath, and are accessible for maintenance. Furthermore, the space provided does not hinder either installation or maintenance.

Architectural Versatility of the system is limited since it cannot accommodate long spans. A maximum square bay of 9.1 m (30 ft) can be achieved for office loads. This will meet the requirements for many structures but may be insufficient for some office structures.

The span to depth ratio of the system is shallower than the other systems. For a 7.62 m (25 ft) floor span the structural floor depth is 584 mm (23 in.). This is shallower than the average depth for this span length. The interior floor depth of the system increases to 813 mm (32 in.) when horizontal service systems are considered. This is also shallower than average.

5.4.16 University of Nebraska System

Structural The initial University of Nebraska system [Low 1991] requires a significant amount of effort during fabrication and erection in order to achieve a floor system which is structurally efficient. The precast beam component which contains voids, requires a major part of the fabrication effort.

Erection requires a number of different labor specialties, and the requirement for cast-in-place concrete may slow erection. Blockouts must be placed in the field to maintain beam voids. Shoring and field placed reinforcement are required only for beams.

The time needed for erection is an important consideration which depends on the erection operations required, coordination required, and the stability of the system. The system calls for cast-in-place connections, and for partially cast-in-place beams. The result is a system which requires that erection on upper stories be delayed until concrete on the lower stories gains sufficient strength. This drawback was recognized and a modified system was developed [Low, Tadros, and Nijhawan 1991]. The modification eliminates the need for cast-in-place concrete. The beam is entirely precast and connections are bolted. This modified system appears superior to the original system in terms of the structural criteria considered in the assessment.

Service Horizontal service systems can be incorporated within the precast components, or suspended beneath the precast structural floor system. The system was evaluated for the former case. A number of problems arise if services are incorporated into the beams and this is reflected in Table 5.8. The beam may be used to house both electrical and HVAC components. A major problem is distributing these services from the beam to other areas of the floor system. If cores of hollow-core planks are utilized, then voids must be provided in the sides of the beams, which decrease the strength of the beams.

Service maintenance is a problem since access is not possible. However, since only the electrical system and HVAC ductwork are encased in the beam, the need for access will be small since these service systems require minimum maintenance.

A potential drawback with incorporating HVAC supply within the beam is the limitation on the capacity of the system. The beam used in example building 1 provides an area of 154,800 sq. mm (240 sq. in.) for the HVAC supply. While this area is inadequate for primary ducts, Table 5.2 indicates that it would be adequate for many of the secondary ducts. However, the HVAC system for example building 1 does not utilize the void provided in the beams because the beams do not provide for the distribution of air to other parts of the floor system. The literature does not indicate how air can be distributed from the beams to the cores of hollow-core planks, or from one beam to another. It is also unclear how the HVAC ducts can pass through the area of the beam-to-column connection.

A disadvantage of the system is the requirement for extensive coordination between structural and service trades in the field. This is reflected in Table 5.8 by the "C" rating shown for this criterion. Both negative moment steel reinforcement and cast-in-place concrete cannot be placed until insulation for the air supply plenum and the conduit or cables for the electrical space are placed in the beam. This coordination requirement may lead to delays or inefficient use of labor in the field.

Architectural The system has limited span versatility but a very efficient structural floor depth. The beam component was designed specifically for typical office spans of 11.0 m (36 ft) or less. Since the floor component utilized is a conventional hollow-core plank, the maximum floor span is approximately 10.7 m (35 ft).

Structural floor depth for example building 1 is 406 mm (16 in.). This is the shallowest depth required for any system in the assessment. The depth for the interior space of the structure assuming that all services are suspended beneath the precast floor system is 711 mm (28 in.), indicating that system has good *building height versatility*.

5.5 SUMMARY

This chapter presents a preliminary assessment of the existing precast structural systems described in Chapter 3. Each system is evaluated based on the criteria identified in Section 4.3. The criteria selected for the assessment of existing precast systems are: *fabrication operations, truck requirements, erection operations, method of service installation, coordination between structural and service trades, service maintenance, service capacity, architectural modification, spatial and functional versatility, and building height versatility*. These criteria are selected because they have a major impact on the efficiency or performance of the building system, and they help identify significant differences between precast structural systems. Section 5.3 applies these assessment criteria to the existing systems described in Chapter 3. The assessment of the existing systems is provided in Section 5.4. Of the 19 precast systems described Chapter 3, 16 are assessed in this section.

The aim of the assessment is to provide insight into the advantages and disadvantages of each precast system and to identify the limitations of each system. This objective is facilitated by comparing each system relative with the other 15 systems included in the assessment. Example buildings 1, 2, and 3 are used to quantify relative differences between systems.

The major findings of the assessment of existing systems can be organized into Structural, Service, and Architectural categories. In the Structural category, the assessment focused on fabrication and erection efficiency. The assessment showed that there is a large variation among systems in the number of precast pieces required for the example building. The number of different forms needed for the example building did not vary significantly among the systems. Systems with large units require less pieces and thus appear to be more efficient to fabricate. However, systems with large units may make it difficult to efficiently transport pieces by truck. There is also a large variation in the level of field effort required for each system. Systems that do not require shoring, extensive field-placed reinforcement or extensive formwork for cast-in-place concrete, and also that have the fewest crane picks, appear to be the most efficient to erect.

In the Service category, the assessment focused on service installation, maintenance, and capacity. The assessment found that the most common method of service installation is to connect the service components on the floor and raise them into position from below. A structural system that allows the services to be installed on a precast surface provided by the structural system (e.g., the Trilposite system), must also integrate the services within the structural system. As a result, structural systems of this type require additional coordination between structural and service trades, and provide reduced access for service maintenance. Structural systems which require the services to be threaded through openings in closely-spaced ribs of the structural components make service installation difficult, and also provide reduced access for service maintenance. Services placed between closely-spaced ribs of the structural system are less accessible for maintenance than services placed below the structural floor system. The placement of service systems below a structural system with a flat bottom appears to provide the best combination of easy installation and access for maintenance. Finally, structural systems with floor and beam openings to accommodate ductwork may indirectly limit the service system capacity. These systems need large openings to avoid limiting service system capacity, and to provide some flexibility in service system design.

In the Architectural category the assessment focused on architectural modification, spatial and functional versatility, and building height versatility. The assessment found that very few of the existing precast structural systems can easily accommodate modification to the architectural system (i.e., adding large vertical openings in the floor system). Most of the structural systems can achieve typical office spans of 9.1 m (30 ft), and a few can achieve significantly larger spans. There is a wide variation among the systems in the total floor depth required for the example building. The total floor depth also varied significantly between locations in the example building. The existing precast structural systems that were designed to minimize the total floor depth appear to have achieved this objective.

| Example Building | Dimensions m x m (ft x ft) | Number of Stories | Interior Beam Spans m (ft) | Floor Spans m (ft) | Direction of Floor Span |
|------------------|----------------------------------|-------------------|----------------------------------|--------------------------|-------------------------|
| 1 | 30.5 x 61 (100 x 200) | 4 | 7.62 (25) | 7.62 (25) | Longitudinal |
| 2 | 30.5 x 61 (100 x 200) | 4 | 7.62 (25) | 15.24 (50) | Longitudinal |
| 3 | 30.5 x 61 (100 x 200) | 4 | 7.62 (25) | 15.24 (50) | Transverse |

Table 5.1. Summary of building parameters for example buildings 1, 2, and 3.

| Section # | Floor Area Served sq. m | Flow Required cms | Max. Duct Velocity m/s | Duct Area Required sq. mm | Duct Dimensions mm x mm (in. x in.) |
|-----------|----------------------------|----------------------|---------------------------|------------------------------|---|
| 1 | 987.06 | 5.014 | 10.16 | 493,550 | 1120 x 458 (44 x 18) |
| 2 | 232.25 | 1.180 | 10.16 | 116,129 | 460 x 255 (18 x 10) |
| 3 | 116.13 | 0.590 | 8.128 | 72,581 | 400 x 200 (16 x 8) |
| 4 | 58.06 | 0.295 | 8.128 | 36,290 | 250 x 150 (10 x 6) |
| 5 | 348.38 | 1.770 | 8.128 | 217,743 | 760 x 300 (30 x 12) |
| 6 | 174.19 | 0.885 | 8.128 | 108,871 | 550 x 200 (22 x 8) |

1 square meter (sq. m) = 10.764 square feet (sq. ft)

1 cubic meter per second (cms) = 2119 cubic feet per minute (cfm)

0.01 cubic meter per second per square meter (cms/m²) = 1.97 cubic feet per minute per square foot (cfm/ft²)

1 meter per second (m/s) = 197 feet per minute (ft/min)

100 square millimeter (sq. mm) = 0.155 square inches (sq. in.)

100 millimeter (mm) = 3.94 inches (in.)

Table 5.2. Required duct sizes for selected sections of horizontal supply network shown in Figure 5.5.

| System | Number of Pieces | Number of Forms |
|----------------------------------|------------------|-----------------|
| U.S. Conventional with HC Planks | 1053 | 4 |
| U.S. Conventional with DTs | 573 (337; 319) | 4 |
| Duotek | 565 (343; 323) | 4 |
| Dycore | 1053 | 3 |
| Dyna-frame | 1952 | 3 |
| Filigree Wideslab | 788 | 3 |
| IMS | 698 | 3 |
| PD2 Frame | 1053 | 4 |
| Prestressed Joist | 1050 (596; 572) | 3 |
| Quickfloor | 1188 | 3 |
| Structurapid | 1188 | 3 |
| Swedish | 1053 | 4 |
| Thomas | 653 (377; 359) | 4 |
| Trilposite | 578 | 2 |
| Contiframe | 1216 | 5 |
| Spanlight | 1053 | 4 |
| University of Nebraska | 1053 | 4 |

Number required for example buildings 2 and 3 is shown in parenthesis.

Table 5.3. Summary of fabrication requirements.

| System | Number of Truck Trips |
|----------------------------------|-----------------------|
| U.S. Conventional with HC Planks | 219 |
| U.S. Conventional with DTs | 211 (209; 202) |
| Duotek | a |
| Dycore | 270 |
| Dyna-frame | 249 |
| Filigree Wideslab | a |
| IMS | a |
| PD2 Frame | a |
| Prestressed Joist | 90 (123; 120) |

| System | Number of Truck Trips |
|------------------------|-----------------------|
| Quickfloor | 280 |
| Structurapid | a |
| Swedish | a |
| Thomas | 253 (305; 295) |
| Trilposite | a |
| Contiframe | a |
| Spanlight | 217 |
| University of Nebraska | 257 |

a - Not enough information available to calculate number of truck trips.
Number required for example buildings 2 and 3 is shown in parenthesis.

Table 5.4. Truck requirements.

| System | Field Operations Required | | | | | | | | |
|----------------------------|---------------------------|---|---|---|---|---|---|---|---|
| | A | B | C | D | E | F | G | H | I |
| U.S. Conventional with HC | | | ✓ | ✓ | ✓ | | | | |
| U.S. Conventional with DTs | | | ✓ | ✓ | ✓ | | | | ✓ |
| Duotek | | | ✓ | ✓ | ✓ | | | | ✓ |
| Dycore | ✓ | ✓ | | | ✓ | ✓ | | | ✓ |
| Dyna-frame | | | | ✓ | ✓ | ✓ | | | ✓ |
| Filigree Wideslab | ✓ | ✓ | | | | ✓ | | ✓ | ✓ |
| IMS | ✓ | | | | ✓ | | ✓ | | |
| PD2 Frame | | | ✓ | ✓ | | ✓ | | | ✓ |
| Prestressed Joist | ✓ | ✓ | | | | ✓ | | ✓ | ✓ |
| Quickfloor | ✓ | | ✓ | | ✓ | ✓ | | | ✓ |
| Structurapid | | | | | ✓ | ✓ | | | ✓ |
| Swedish | | | ✓ | ✓ | ✓ | | | | |
| Thomas | | | ✓ | ✓ | | | | | ✓ |
| Trilposite | ✓ | ✓ | | | ✓ | ✓ | | ✓ | ✓ |
| Contiframe | | | ✓ | | ✓ | | | | |
| Spanlight | ✓ | | | | ✓ | ✓ | ✓ | | ✓ |
| University of Nebraska | ✓ | | | | ✓ | ✓ | | ✓ | ✓ |

All systems require column bracing. All systems require precast members to be aligned and leveled.

Key to Field Operations:

- | | |
|---|---|
| A. Erect shoring, remove shoring. | F. Place reinforcement. |
| B. Construct formwork, remove formwork. | G. Place prestressing cables, tension cables. |
| C. Bolt connections. | H. Place blockouts. |
| D. Weld connections. | I. Place concrete, finish concrete. |
| E. Grout connections | |

A check (✓) indicates that this field operation is required.

Table 5.5. Summary of required field operations.

| System | Shoring Requirements | Reinforcement/ Post-tensioning | Quantity of Cast-In-Place (cubic meters) |
|----------------------------------|----------------------|--------------------------------|--|
| U.S. Conventional with HC Planks | 0 | 0 | 0 |
| U.S. Conventional w/ DTs | 0 | 0 | 377 |
| Duotek | 0 | 0 | 377 |
| Dycore | Beam | Beam | 265 |
| Dyna-frame | Beam | Beam | 76 |
| Filigree Wideslab | Beam, Floor | Beam, Floor | a |
| IMS | Beam, Floor | Beam, Floor | 0 |
| PD2 Frame | 0 | Beam | 0 |
| Prestressed Joist | Beam | Beam, Floor | 717* |
| Quickfloor | Beam | Beam | 906 |
| Structurapid | Beam | Beam | a |
| Swedish | 0 | 0 | 0 |
| Thomas | Beam | Beam | 220 |
| Trilposite | Beam, Floor | Beam, Floor | 803* |
| Contiframe | 0 | 0 | 0 |
| Spanlight | Beam, Floor | Beam | 147 |
| University of Nebraska | Beam | Beam | 575 |

1 cubic meter = 1.309 cubic yards

a - Information was not available.

Beam - This field operation is required for the beam component.

Floor - This field operation is required for the floor component.

* Formwork required

Table 5.6. Field effort required.

| System | # of Pieces | # of Picks |
|----------------------------------|-------------|------------|
| U.S. Conventional with HC Planks | 1053 | 520 |
| U.S. Conventional with DTs | 573 | 573 |
| Duotek | 565 | 565 |
| Dycore | 1053 | 520 |
| Dyna-frame | 1952 | 885 |
| Filigree Wideslab | 788 | 788 |
| IMS | 698 | 698 |
| PD2 Frame | 1053 | 520 |
| Prestressed Joist | 1050 | 609 |
| Quickfloor | 1188 | 655 |
| Structurapid | 1188 | 655 |
| Swedish | 1053 | 520 |
| Thomas | 653 | 653 |
| Triposite | 578 | 578 |
| Contiframe | 1216 | 683 |
| Spanlight | 1053 | 520 |
| University of Nebraska | 1053 | 520 |

(a)

| System | # of Picks (Bldg. 1) | # of Picks (Bldg. 2) | # of Picks (Bldg. 3) |
|-------------------------|----------------------|----------------------|----------------------|
| U.S Conventional w/ DTs | 573 | 337 | 319 |
| Duotek | 565 | 343 | 323 |
| Prestressed Joist | 609 | 383 | 359 |
| Thomas | 653 | 377 | 359 |

(b)

Table 5.7. Crane picks required: a) Example building 1; b) Comparison between example buildings 1, 2, and 3.

| System | Method of Service Installation A to C (Section 5.3.2.1) | Coordination Between Structural and Service Trades A to C | Service Maintenance A to F (Section 5.3.2.3) |
|-------------------------------------|---|--|--|
| U.S. Conventional with HC planks | B | A | A |
| U.S. Conventional with DTs | B | A | C |
| Duotek | C | A | D |
| Dycore | B | B | A |
| Dyna-frame | B | A | B |
| Filigree Wideslab | B | B | A |
| IMS | B | A | A |
| PD2 Frame | B | A | A |
| Prestressed Joist | B | B | A |
| Quickfloor | B | B | A |
| Structurapid | B | A | A |
| Swedish | B | B | B |
| Thomas | B | A | C |
| Trilposite [†] | A,C | C | E |
| Contiframe | B | A | A |
| Spanlight | B | A | A |
| University of Nebraska [*] | A | C | F |

Note: For *method of service installation* and *service maintenance* electrical services are not considered.

† The Trilposite system received an "A", and a "C" for installation because while the floor system provides a platform for installation, services still need to be threaded through openings hindering the installation process.

* This precast system as described may accommodate services within the beam component. The system is evaluated assuming services will be housed in the beam component.

Table 5.8. Evaluation of service efficiency and performance.

| System | Practical Span Range for Office Loading | |
|----------------------------------|---|------------------------|
| | Beams (meter) | Floor Units (meter) |
| U.S. Conventional with HC Planks | 6.1 - 12.2 | 4.6 - 10.7 |
| U.S. Conventional with DTs | 6.1 - 12.2 | 6.1 - 18.3 |
| Duotek | 6.1 - 9.14 | 6.1 - 18.3 |
| Dycore | 4.6 - 10.7 | 4.6 - 10.7 |
| Dyna-frame | 4.6 - 12.2 | 4.6 - 10.7 |
| Filigree Wideslab | 4.6 - 7.6 | 4.6 - 9.1 |
| IMS | a | 2.4 - 7.2 |
| PD2 Frame | 6.1 - 12.2 | 4.6 - 10.7 |
| Prestressed Joist | 4.6 - 12.2 | 4.6 - 15.2 |
| Quickfloor | 4.5 - 10.0 | 4.5 - 10.0 |
| Structurapid | 3.1 - 7.6 | 4.6 - 7.6 |
| Swedish | 6.1 - 12.2 | 6.1 - 12.2 |
| Thomas | a | 6.1 - 18.3 |
| Trilposite | 2.5 - 6.1 | 4.0 - 10.7 |
| Contiframe | 4.6 - 9.1 | 4.6 - 9.1 |
| Spanlight | 4.6 - 9.1 | 4.6 - 9.1 |
| University of Nebraska | 5.0 - 11.0 | 5.0 - 10.7 |

1 meter = 3.28 feet

a - Information not available.

Table 5.9. Spatial versatility.

| System | Structural Floor Depth (mm) | Total Floor Depth (mm) | | |
|----------------------------------|-----------------------------|------------------------|-----------|----------|
| | | Corridor | Perimeter | Interior |
| U.S. Conventional with HC Planks | 660 | 1321 | 1067 | 864 |
| U.S. Conventional with DTs | 711 | 1372 | 1118 | 965 |
| Duotek | 1016 | 1473 | 1219 | 1219 |
| Dycore | 508 | 1168 | 914 | 711 |
| Dyna-frame | 711 | 914 | 1118 | 914 |
| Filigree Wideslab | a | a | a | a |
| IMS | a | a | a | a |
| PD2 Frame | 650 | 1321 | 1067 | 853 |
| Prestressed Joist | 572 | 1232 | 978 | 914 |
| Quickfloor | 560 | 1220 | 966 | 768 |
| Structurapid | a | a | a | a |
| Swedish | 711 | 1372 | 1118 | 914 |
| Thomas | a | a | a | a |
| Triposite | a | a | a | a |
| Contiframe | 660 | 1321 | 1067 | 864 |
| Spanlight | 584 | 1245 | 991 | 813 |
| University of Nebraska | 406 | 1067 | 813 | 711 |

a - Information not available

Average structural floor depth = 645 mm

Average total floor depth:

Corridor = 1248 mm

Perimeter = 1036 mm

Interior = 876 mm

100 mm = 3.94 inches

Table 5.10. Building height versatility. Total floor depth values are provided for the interior, corridor, and perimeter of the building. The ceiling is dropped in both the corridor and perimeter of the building to accommodate ductwork.

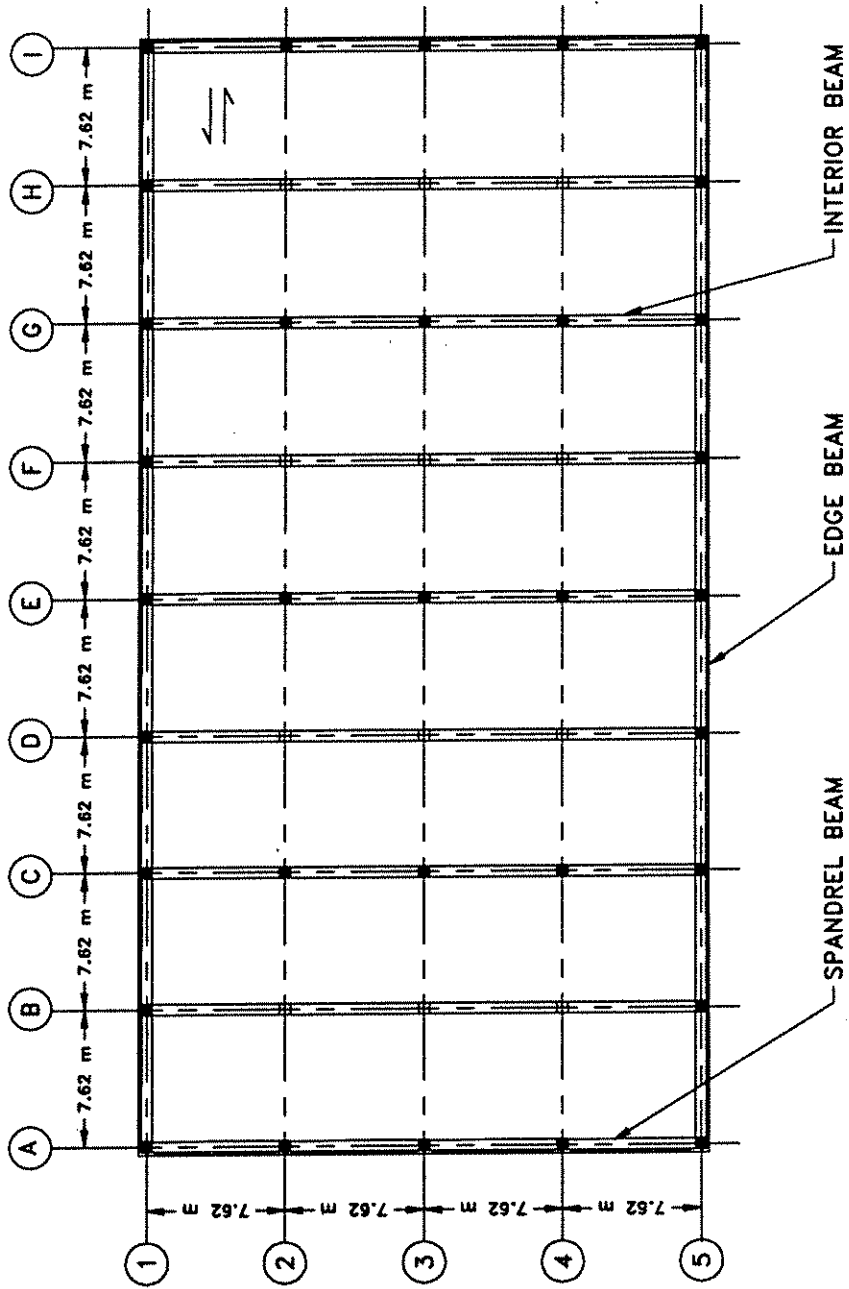

Figure 5.1. Example building 1. Structural layout.

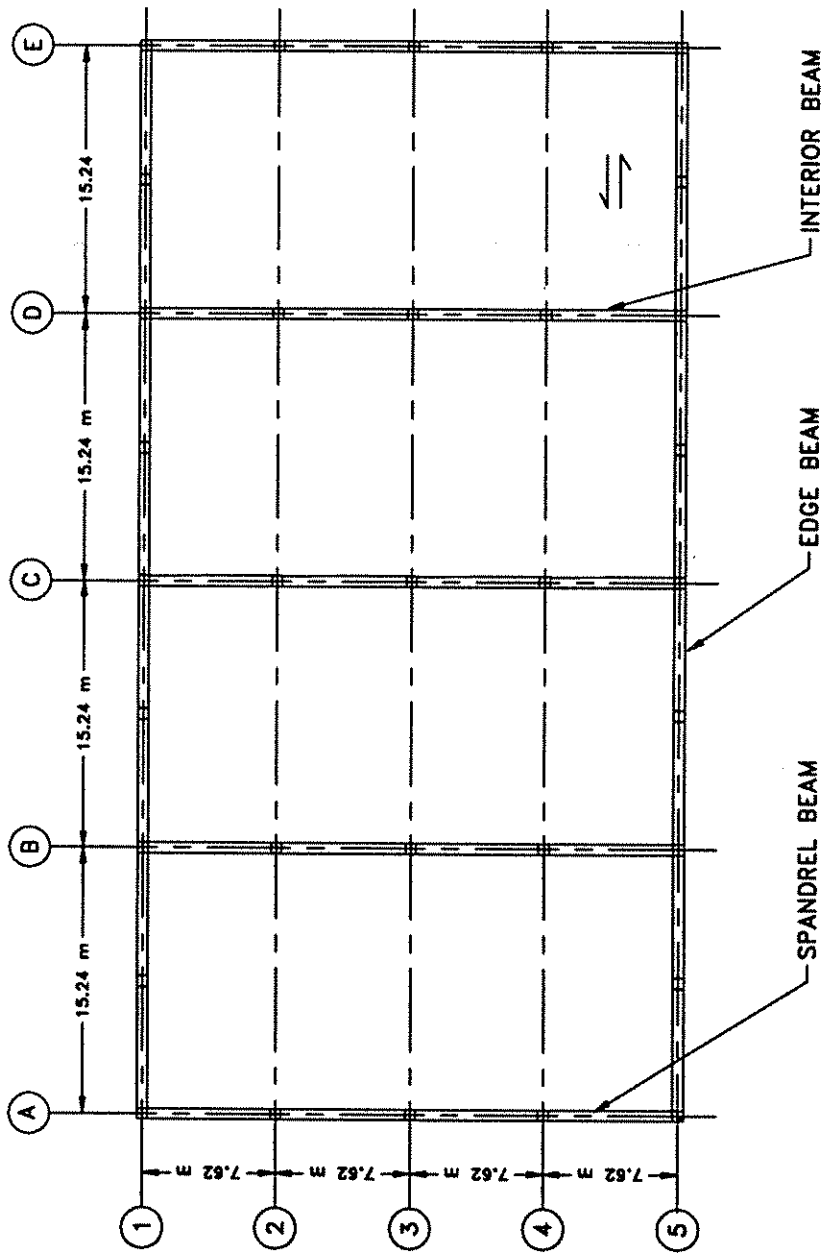

Figure 5.2. Example building 2. Structural layout.

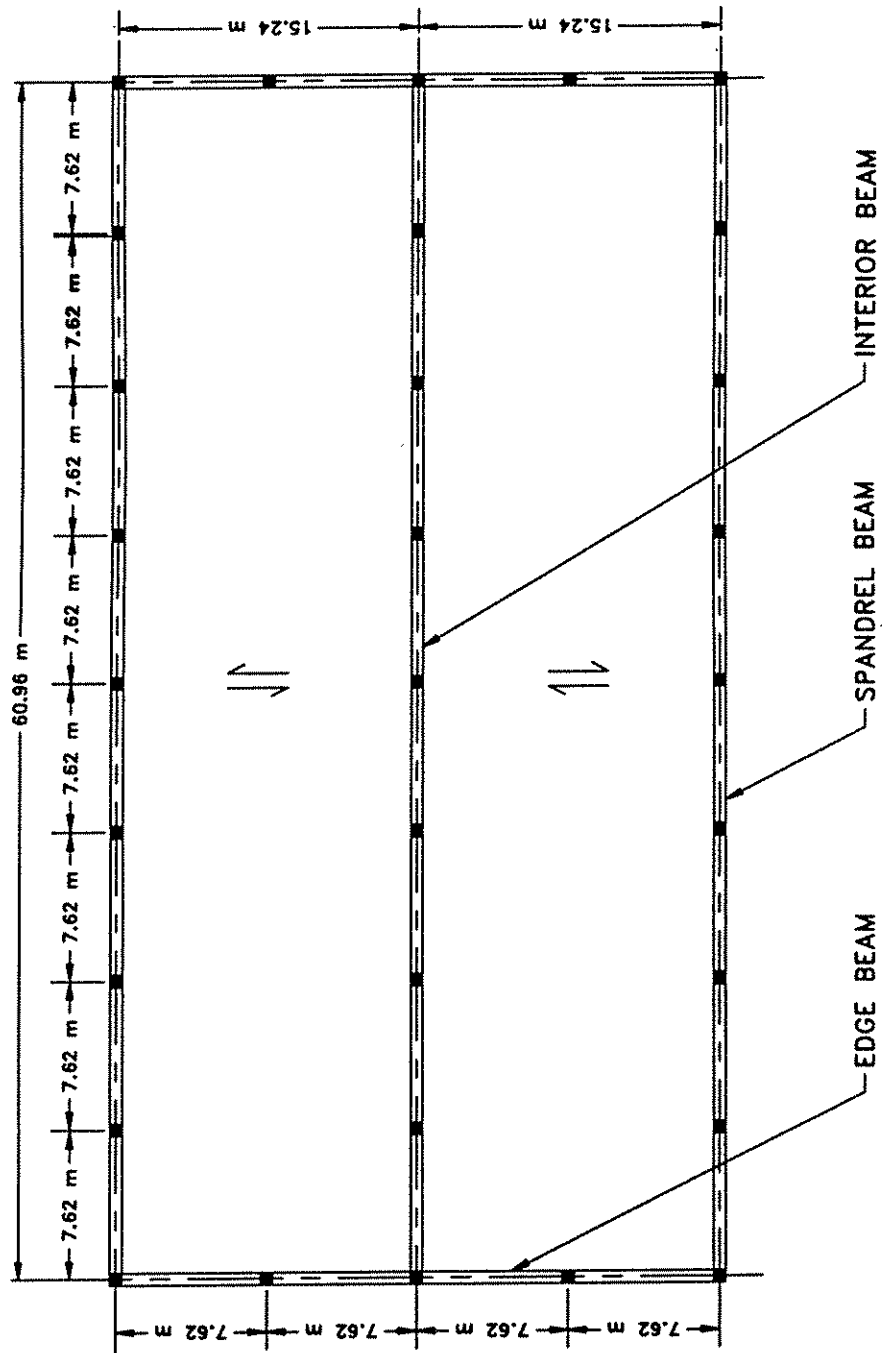

Figure 5.3. Example building 3. Structural layout.

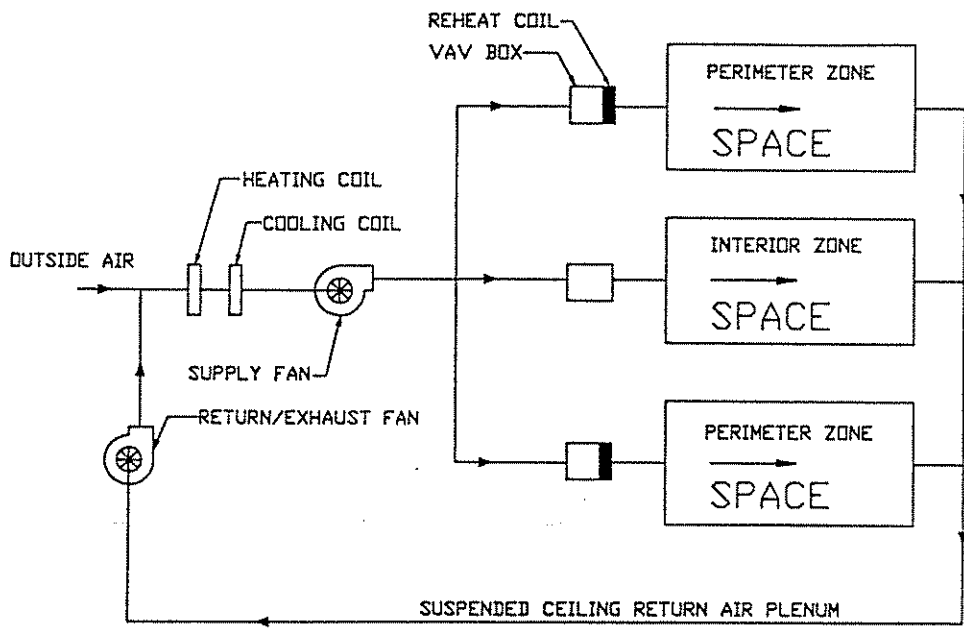

Figure 5.4. Schematic of typical HVAC system used for example building 1.

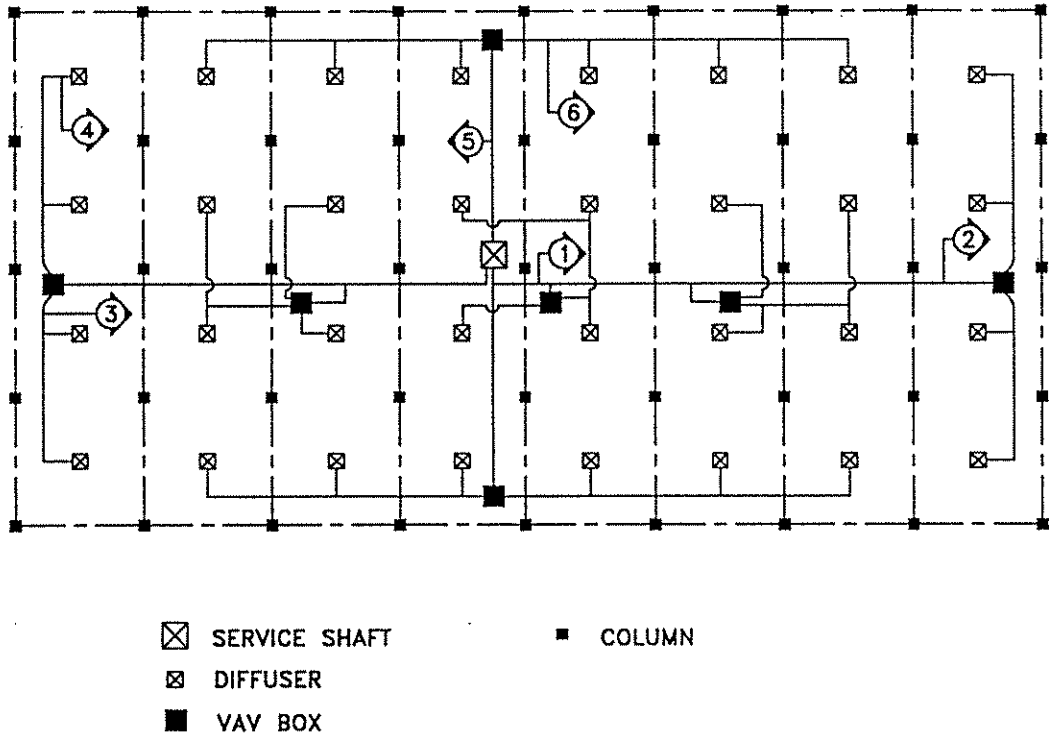

Figure 5.5. HVAC layout, example building 1.

Chapter 6

Opportunities For New Precast Structural Systems

6.1 INTRODUCTION

This chapter identifies opportunities for the development of new precast structural systems. The opportunities are presented in terms of desired physical attributes of the structural system which lead to improved structural, service, and architectural efficiency and performance.

In some cases the desired physical attributes of the structural system are directly linked to improved structural, service, and architectural efficiency and performance. In other cases, the desired physical attributes of the structural system are linked to desired physical attributes of the service or architectural systems, and these service or architectural system attributes lead to improved efficiency and performance.

The impact of a particular physical attribute is presented in terms of selected criteria from Chapter 4. As will be shown in the sections that follow, many of the physical attributes impact more than one efficiency and/or performance criterion. In some cases, contradictions arise whereby a given change in a particular physical attribute may cause improved efficiency and/or performance in terms of some criteria, but reduced efficiency and/or performance in terms of other criteria.

Section 6.2, 6.3 and 6.3 address the desired physical attributes of the structural system which lead to improved structural, service and architectural efficiency and/or performance.

6.2 STRUCTURAL EFFICIENCY AND PERFORMANCE

A number of physical attributes of the precast structural system are linked directly to improved structural efficiency and performance. The desired changes in these physical attributes are listed in Table 6.1, along with the efficiency and performance criteria impacted by these attributes.

As indicated in Table 6.1, reducing the number of precast pieces and reducing the number of different precast pieces may be used to improve the efficiency of fabrication operations. Fabrication operations may also be improved by developing structural members which can be mass produced, and by increasing modularity.

Smaller precast pieces, which group together efficiently on a truck, may be used to improve transportation efficiency.

Reducing the number of precast pieces to reduce handling requirements, reducing the quantity of field placed reinforcement, and reducing the required amount of formwork for cast-in-place concrete may improve erection efficiency. Erection efficiency may also be improved by reducing the number of connections and by simplifying connections to allow for quick erection. An opportunity exists in developing self-aligning connections which reduce labor and increase construction safety.

Increasing member strength and connection strength may be used to improve structural performance. Performance may be further improved by developing shallow floor and beam members with high stiffness so that deflections are not the design limitation. High strength concrete may be used to increase member strength, with the benefits of lower prestress losses, and smaller deflections. High strength concrete may also be used to reduce shear reinforcement. It is estimated that material costs will increase between 5 and 10% for each additional 7 MPa (1000 psi) increase in concrete strength over a minimum of 28 MPa (4000 psi) [Aswad and Hester 1985].

6.3 SERVICE EFFICIENCY AND PERFORMANCE

Several physical attributes of the precast structural system can impact service efficiency and performance. As indicated in Table 6.2, reducing structural depth may increase the space available for services, which in turn improves service design, installation, capacity and versatility. Reducing structural depth may also contribute to a reduction in total floor depth. This reduces the heating, ventilating, and air conditioning volume of the building and thus improves the efficiency of service operation. However, if a reduction in structural depth is used solely to reduce floor depth and not to increase space for services, then the improvements in service design, installation, capacity and versatility are not obtained.

The use of large horizontal openings in members may improve service efficiency and performance. Specifically, large horizontal openings can contribute to increased space for services, which may improve service design, installation, maintenance, modification, capacity and versatility. For this improvement to be realized, the openings must be sufficiently large to easily accommodate the main components of the service systems (e.g., main HVAC ducts). Otherwise such openings may prove inefficient except perhaps for smaller services such as secondary ductwork, plumbing and electrical conduit. If the openings are too small, integration of services through the openings should be avoided to improve service design, installation, maintenance and modification.

Integration of services in the structural system is another approach to reduce total floor depth and thus reduce building volume, again leading to an improvement in the efficiency of service operation. However, as noted above, if services are integrated using openings that are limited in size, inefficiencies in service design and installation may result. Services should not be integrated by encasement within the structural system, unless the service requires little or no maintenance. Examples of this include electrical conduit and a return air plenum.

In ribbed floor systems, increasing the space between ribs will increase space for services, and may therefore improve the efficiency of service maintenance and service modification.

6.4 ARCHITECTURAL EFFICIENCY AND PERFORMANCE

A number of physical attributes of the structural system can impact architectural efficiency and performance, as shown in Table 6.3. The relationships shown in group A involve only the precast structural system. For the relationships shown in group B, the desired physical attributes of the structural system are linked to desired physical attributes of the service or architectural systems, and these service or architectural system attributes lead to improved structural, service and architectural efficiency and performance.

As shown in Table 6.3, an increase in the modularity of the precast structural system may improve the efficiency of architectural design. Further, the ability to accommodate large vertical openings leads to efficient architectural modification. Precast structural systems need to achieve a range of span lengths, accommodate non-rectilinear spaces, and accommodate large vertical openings in order to achieve spatial and functional versatility.

The relationships shown in group B show that reducing structural depth and integrating services reduce the total floor depth, and that a reduced total floor depth will result in more efficient use of architectural materials and improved performance with respect to versatility in building height.

6.5 SUMMARY

This chapter identifies opportunities for the development of new precast structural systems. The opportunities are presented in terms of desired physical attributes of the structural system which lead to improved structural, service, and architectural efficiency and performance.

Opportunities to improve structural efficiency and performance include:

1. Reduce the number of pieces, reduce the number of different pieces, use pieces which can be mass produced, and increase modularity to improve the efficiency of structural fabrication.
2. Use smaller precast pieces, which group together efficiently on a truck, to improve transportation efficiency.
3. Reduce the number of precast pieces, reduce the quantity of field-placed reinforcement, reduce the required amount of formwork for cast-in-place concrete, reduce the number of connections, and simplify connections to allow for quick erection to improve the efficiency of erection operations.
4. Increase member strength, connection strength, and member stiffness to improve structural performance in terms of overall strength and deflections.

Opportunities to improve service efficiency and performance include:

1. Reduce the depth of the structural system, avoid the integration of services in restrictive openings in the structural system to increase space for services, and therefore to improve service design, installation, capacity and versatility.
2. Increase the space between ribs in ribbed structural systems to increase space for services and thereby improve efficiency of service maintenance and modification.
3. Avoid the integration of services in restrictive openings in the structural system to increase space for services, and therefore to improve the efficiency of service maintenance and modification.

4. Reduce structural depth and integrate services in the structural system to reduce building volume by reducing total floor depth, and therefore to increase the operation efficiency of heating, ventilating and air conditioning service systems.
5. Reduce structural depth and use large horizontal openings that easily accommodate service systems to increase the space for services, and therefore to improve the performance of the service systems in terms of capacity and versatility.

Opportunities to improve architectural efficiency and performance include:

1. Increase modularity in the structural system to improve the efficiency of architectural design.
2. Provide the ability to accommodate large vertical openings in the structural system to improve the efficiency of architectural modification.
3. Provide the ability to accommodate large vertical openings, a range of span lengths, and non-rectilinear floor plans to improve the architectural performance in terms of spatial and functional versatility.
4. Reduce structural depth and integrate services in the structural system to improve the efficient use of architectural materials and improve the performance in terms of building height versatility.

Objective: Improve structural efficiency and performance

| Criteria Considered | Approach (Structural System) |
|---|---|
| Efficiency Fabrication Operations | Reduce number of precast pieces Reduce number of different precast pieces Use pieces which can be mass produced Increase modularity |
| Truck Requirements | Use smaller pieces which group together efficiently |
| Erection Operations | Reduce number of precast pieces Reduce quantity of field-placed reinforcement Reduce formwork for cast-in-place concrete Simplify and reduce the number of connections |
| Performance Strength | Increase member strength Increase connection strength |
| Deflection of Structural Floor System | Increase member stiffness |

Table 6.1. Approach to improve structural efficiency and performance.

Objective: Improve service efficiency and performance

| Criteria Considered | Approach | |
|--|--|---|
| | (Service and Architectural System) | (Structural System) |
| Efficiency Service Design and Service Installation | Increase space for services | Reduce structural depth Avoid integration of services Use large horizontal openings |
| Service Maintenance and Service Modification | Increase space for services | Increase space between tee stems |
| | Avoid encased or restricted access | Use large horizontal openings Avoid integration of services |
| Service Operation | Reduce building volume by reducing total floor depth | Reduce structural depth Integrate services |
| Performance Service Capacity | Increase space for services | Reduce structural depth Use large horizontal openings |
| Service Versatility | Increase space for services | Reduce structural depth Use large horizontal openings |

Table 6.2. Approach to improve service efficiency and performance.

Objective: Improve architectural efficiency and performance

| Criteria Considered (Group A) | Approach (Structural System) |
|--|--|
| Efficiency Architectural Design | Increase modularity |
| Architectural Modification | Accommodate large vertical openings |
| Performance Spatial and Functional Versatility | Accommodate a range of span lengths Accommodate non-rectilinear spaces Accommodate large vertical openings |

| Criteria Considered (Group B) | Approach | |
|---|---|---|
| | (Service and Architectural System) | (Structural System) |
| Efficiency Architectural Construction - materials | Reduce total floor depth | Reduce structural depth Integrate services |
| Performance Building Height Versatility | Reduce total floor depth | Reduce structural depth Integrate services |

Table 6.3. Approach to improve architectural efficiency and performance.

Chapter 7

Conclusions and Future Work

7.1 INTRODUCTION

The research presented in this report is part of a project titled *Development of New Floor Framing Systems for Gravity Loads*. This project has two broad objectives:

1. To explore the development of new structural systems for gravity loads; and,
2. To develop a methodology for the systematic comparison and evaluation of different structural systems.

The present work focuses on the development of new concepts for precast concrete floor systems for gravity loads for application in occupied office buildings with regular spacing of columns or bearing walls.

The present work has been separated into three tasks as follows:

Task 1: Assess current and emerging precast concrete structural floor systems

- Task 1.1 - survey of current and emerging precast structural systems;
- Task 1.2 - develop assessment criteria to evaluate precast structural systems;
- Task 1.3 - apply assessment criteria to precast structural systems in the survey.

Task 2: Develop new concepts for precast structural floor systems

- Task 2.1 - identify opportunities for new precast structural systems;
- Task 2.2 - propose new precast structural systems; and
- Task 2.3 - apply assessment criteria to new precast structural systems.

Task 3: Detailed development of most promising new concepts from Task 2.

This progress report describes the results of work performed up to and including Task 2.1 - identification of opportunities for new precast structural systems.

The survey of systems (Task 1.1) includes 19 precast concrete structural systems developed in the last 30 years in the United States and abroad. This is presented in Chapter 3 and includes a description of the structural system, construction procedure, and the method of incorporating HVAC, plumbing, and electrical systems.

Assessment criteria are established (Task 1.2) to provide a consistent method for evaluating the effectiveness of the different systems in the survey. The assessment criteria are also used to guide the development of new systems (Task 2). Development of the criteria involved extensive industry interaction. Chapter 4 presents the development of the assessment criteria. The criteria are considered preliminary because verification of the criteria through further interaction with industry is needed.

The assessment criteria are applied to the systems in the survey to provide an indication of the current state-of-the-art in precast concrete structural systems (Task 1.3). This is presented in Chapter 5. The assessment is considered to be preliminary because the criteria used in the assessment need further verification, and because only one example building was considered.

Finally, the opportunities that are identified from the assessment are discussed in Chapter 6. These opportunities will serve as the basis for the development of new systems.

7.2 CONCLUSIONS

The major findings from the preliminary assessment of existing systems presented in Chapter 5 are as follows:

1. In the Structural category, the assessment focused on fabrication and erection efficiency. The assessment showed that there is a large variation among systems in the number of precast pieces required for the example building. The number of different forms needed for the example building did not vary significantly among the systems. Systems with large units require less pieces and thus appear to be more efficient to fabricate. However, systems with large units may make it difficult to efficiently transport pieces by truck. There is also a large variation in the level of field effort required for each system. Systems that do not require shoring, extensive field-placed reinforcement or extensive formwork for cast-in-place concrete, and also that have the fewest crane picks, appear to be the most efficient to erect.
2. In the Service category, the assessment focused on service installation, maintenance, and capacity. The assessment found that the most common method of service installation is to connect the service components on the floor and raise them into position from below. A structural system that allows the services to be installed on a precast surface provided by the structural system, must also integrate the services within the structural system. As a result, structural systems of this type require additional coordination between structural and service trades, and provide reduced access for service maintenance. Structural systems which require the services to be threaded through openings in closely-spaced ribs of the structural components make service installation difficult, and also provide reduced access for service maintenance. Services placed between closely-spaced ribs of the structural system are less accessible for maintenance than services placed below the structural floor system. The placement of service systems below a structural system with a flat bottom appears to provide the best combination of easy installation and access for maintenance. Finally, structural systems with floor and beam openings to accommodate ductwork may indirectly limit the service system capacity. These systems need large openings to avoid limiting service system capacity, and to provide some flexibility in service system design.
3. In the Architectural category the assessment focused on architectural modification, spatial and functional versatility, and building height versatility. The assessment found that very few of the existing precast structural systems can easily

accommodate modification to the architectural system (i.e., adding large vertical openings in the floor system). Most of the structural systems can achieve typical office spans of 9.1 m (30 ft), and a few can achieve significantly larger spans. There is a wide variation among the systems in the total floor depth required for the example building. The total floor depth also varied significantly between locations in the example building. The existing precast structural systems that were designed to minimize the total floor depth appear to have achieved this objective.

The opportunities for the development of new precast structural systems identified in Chapter 6 are summarized below. Opportunities to improve structural efficiency and performance include:

1. Reduce the number of pieces, reduce the number of different pieces, use pieces which can be mass produced, and increase modularity to improve the efficiency of structural fabrication.
2. Use smaller precast pieces, which group together efficiently on a truck, to improve transportation efficiency.
3. Reduce the number of precast pieces, reduce the quantity of field-placed reinforcement, reduce the required amount of formwork for cast-in-place concrete, reduce the number of connections, and simplify connections to allow for quick erection to improve the efficiency of erection operations.
4. Increase member strength, connection strength, and member stiffness to improve structural performance in terms of overall strength and deflections.

Opportunities to improve service efficiency and performance include:

1. Reduce the depth of the structural system, avoid the integration of services in restrictive openings in the structural system to increase space for services, and therefore to improve service design, installation, capacity and versatility.
2. Increase the space between ribs in ribbed structural systems to increase space for services and thereby improve efficiency of service maintenance and modification.
3. Avoid the integration of services in restrictive openings in the structural system to increase space for services, and therefore to improve the efficiency of service maintenance and modification.
4. Reduce structural depth and integrate services in the structural system to reduce building volume by reducing total floor depth, and therefore to increase the operation efficiency of heating, ventilating and air conditioning service systems.

5. Reduce structural depth and use large horizontal openings that easily accommodate service systems to increase the space for services, and therefore to improve the performance of the service systems in terms of capacity and versatility.

Opportunities to improve architectural efficiency and performance include:

1. Increase modularity in the structural system to improve the efficiency of architectural design.
2. Provide the ability to accommodate large vertical openings in the structural system to improve the efficiency of architectural modification.
3. Provide the ability to accommodate large vertical openings, a range of span lengths, and non-rectilinear floor plans to improve the architectural performance in terms of spatial and functional versatility.
4. Reduce structural depth and integrate services in the structural system to improve the efficient use of architectural materials and improve the performance in terms of building height versatility.

7.3 FUTURE WORK

As noted previously, this progress report describes the results of work performed up to and including Task 2.1 - identification of opportunities for new precast structural systems. A second report (van Zyverden et al. in preparation) describes the concepts that have been developed for new systems (Tasks 2.2 and 2.3). Future work (Task 3) involves the detailed development of the most promising new concepts. This will include the development of design examples and details. Additional work is needed to review and verify the preliminary assessment criteria, and to review and verify the preliminary assessment of existing precast structural systems presented in this report.

REFERENCES

- Alexander, S., "The SPENN-Group of Norway, Concrete Precasting Plant and Technology," *Betonwerk + Fertigteil-Technik*, No. 3, 1990, pp. 65-66.
- Allen, D. E., "Building Vibrations from Human Activities," *Concrete International*, V. 12, No. 6, June 1990.
- ASHRAE, *ASHRAE Handbook - Fundamentals - 1989*, American Society of Heating, Refrigerating and Air-Conditioning Engineers, Inc., Atlanta, GA, 1989.
- ASHRAE, *ASHRAE Handbook - Heating, Ventilating, and Air-Conditioning Applications - 1991*, American Society of Heating, Refrigerating and Air-Conditioning Engineers, Inc., Atlanta, GA, 1991.
- ASHRAE, *ASHRAE Handbook - Heating, Ventilating, and Air-Conditioning Systems and Equipment - 1992*, American Society of Heating, Refrigerating and Air-Conditioning Engineers, Inc., Atlanta, GA, 1992.
- Aswad, A., and Weston, H. T., "Impact of High-Strength Concrete on Design and Service Behavior of Prestressed Precast Concrete Members," *High-Strength Concrete, SP-87*, American Concrete Institute, Detroit, MI, 1985.
- Bison Concrete, *PD2 FRAME*, Company literature - Bison Concrete Limited, Buckinghamshire, Great Britain, February, 1970.
- Cast-Crete Tampa, *Prestressed Tensile System*, Company literature - Cast-Crete Tampa, A Division of Florida Engineered Construction Products, FL.
- Construction News, "Precast slab faces a testing time," *Construction News*, London, England, September 5, 1991, p. 20.
- Contiframe Structures, *Contiframe, The Natural Progression*, Company literature - Contiframe Structures Limited, Atherstone, Warwickshire, Great Britain, 1992.
- Diamant, R., *Industrialized Building 2 - 50 International Methods*, Second edition, Liffé Books Ltd., London, 1965, pp. 42-44.
- Dow Mac, *Spanlight Precast Frame System*, Company literature - Dow Mac Projects, Precast Concrete Division of Costain Building Products Ltd., London, England, 1991.
- Ericson, A. C., and Warnes, C. E., *Precast Prestressed Concrete Parking Structures. Framing Systems and Connection Technology*, CPM Associates, Sacramento, CA.
- Finfrock Industries, *Composite Dycore Office Structures*, Company literature - Finfrock Industries, Inc., Orlando, FL, 1992.

Flexicore Systems, *Specifications for the DYNA-FRAME System*, Flexicore Systems, Inc., Huber Heights, OH, 1992.

Fogarasi, G., *Prestressed Concrete Technology*, Akademiai Kiado, Budapest, Hungary, 1986, pp. 256-264.

Grimm, N. R., and Rosaler, R. C., *Handbook of HVAC Design*, McGraw - Hill Publishing Company, NY, 1990.

Low, S.-G., *Minimization of Floor Thickness in Multistory Buildings*, MSc thesis, University of Nebraska-Lincoln, NE, 1991.

Low, S.-G., Tadros, M. K. and Nijhawan, J. C., "Minimization of Floor Thickness in Precast Multistory Buildings," *PCI JOURNAL*, V. 36, No. 4, July-Aug., 1991, pp. 74-92.

Martin, L. D., and Korkosz, W. J., *Connections for Precast Prestressed Concrete Buildings*, Prestressed Concrete Institute, March, 1982.

Means, *Means Assemblies Cost Data 1992*, Kingston, MA, R.S. Means Company, Inc., 1992.

Mid-State Filigree Systems, *The Filigree Wideslab Method of Concrete Deck Construction*, Company literature - Mid-State Filigree Systems, Inc., Cranbury, NJ, 1992.

Omnia Concrete Floors, *OMNIDEC General Information*, Company literature - Omnia Concrete Floors Limited, Cheshire, Great Britain, 1988.

Ontario Precast Concrete Manufacturers Association and PCA, *Duotek*, Portland Cement Association, Skokie, IL.

Østspenn Holding A/S, *OHS Systems*, Company literature - SPENN Group, Østspenn Holding A/S, Honefoss, Norway, 1991.

PCI, *PCI Design and Typical Details of Connections for Precast and Prestressed Concrete*, Prestressed Concrete Institute, second edition, 1988.

PCI, *PCI Design Handbook*, Prestressed Concrete Institute, fourth edition, 1992.

PCA, *Details of the Tri/posite System*, Portland Cement Association, Skokie, IL 1969.

Perry, E. D., "The Dyna-Frame System of Structural Building Elements," Paper presented at PCI Convention, Montreal, October, 1967.

Petrovic, B., and Dimitrijevic, R., "Prefabricated Prestressed Concrete Skeleton System IMS," *Housing Science*, V. 2, No. 4, 1978, pp 369-375.

Price Brothers, *Flexicore decks and systems building*, Company literature - Price Brothers Company, Dayton, OH, 1989.

Prestressed Systems Industries, *The Composite Prestressed Concrete Framing System*, Company literature - Prestressed Systems Industries, Inc., Miami, FL.

Quickfloor America, *Quickfloor Integrated Building Systems*, Company literature - Quickfloor America, Inc., Portolla, CA, 1990.

Rise, G., *A Swedish Precast Concrete System For Multi-story Utility Buildings*, AB Strangbetong, Stockholm, Sweden.

Strescon Industries, *The Dyna-Frame Difference*, Company literature - Strescon Industries, Inc., Baltimore, MD.

Thomas Concrete, *M.D. Medical Tower* - Structural design drawings, Thomas Concrete Products, Oklahoma City, OK, 1985.

Thoresen, B. O., and Alexander, S., "Development work gives cost savings. New corbel free beam/column connection," Østlandske Spennbetong A/S, Honefoss, Norway, 1990.

Trent Concrete Structures, *Trent T6 Precast Structural Frames*, Company literature - Trent Concrete Structures Limited, Colwick, Nottingham, Great Britain, 1992.

van Zyverden, W., Prior, R., Pessiki, S., Sause, R., Slaughter, S., "Preliminary Concepts for New Floor Framing Systems for Precast Concrete Office Buildings," ATLSS Report, in preperation.

Warnes, C. E., *Precast Concrete Connection Details Which Meet U.S. Building Code Requirements In All Seismic Zones*, CPM Associates, Sacramento, CA, 1991.

Warnes, C. E., *Precast Concrete Moment Frames, Part 1: Concepts*, CPM Associates, Sacramento, CA.

Yoshizaki, S., Sugano, S., Yoshioka, K., Mikame, A., Yagishita, K., and Iso, K., *Existing Precast Frame Systems in Japan*, First Meeting of the U.S.-Japan Joint Technical Coordinating Committee on Precast Seismic Structural Systems (JTCC-PRESS), San Diego, CA, November 29, 1990.



