

4-1-2003

# Development of the Characteristic Section Method to Estimate Thermal R-Values for Precast Concrete Sandwich Wall Panels

Stephen Pessiki

You-Jung Lee

Follow this and additional works at: <http://preserve.lehigh.edu/engr-civil-environmental-atlss-reports>

---

## Recommended Citation

Pessiki, Stephen and Lee, You-Jung, "Development of the Characteristic Section Method to Estimate Thermal R-Values for Precast Concrete Sandwich Wall Panels" (2003). ATLSS Reports. ATLSS report number 03-06.  
<http://preserve.lehigh.edu/engr-civil-environmental-atlss-reports/27>

This Technical Report is brought to you for free and open access by the Civil and Environmental Engineering at Lehigh Preserve. It has been accepted for inclusion in ATLSS Reports by an authorized administrator of Lehigh Preserve. For more information, please contact [preserve@lehigh.edu](mailto:preserve@lehigh.edu).



**LEHIGH**  
UNIVERSITY

**DEVELOPMENT OF THE CHARACTERISTIC SECTION METHOD  
TO ESTIMATE THERMAL R-VALUES FOR PRECAST  
CONCRETE SANDWICH WALL PANELS**

by

**You-Jung Lee**

**Stephen Pessiki**

**ATLSS Report No. 03-06**

April 2003

**ATLSS is a National Center for Engineering Research  
on Advanced Technology for Large Structural Systems**

117 ATLSS Drive  
Bethlehem, PA 18015-4729

Phone: (610)758-3525  
Fax: (610)758-5902

[www.atlss.lehigh.edu](http://www.atlss.lehigh.edu)  
Email: [inatl@lehigh.edu](mailto:inatl@lehigh.edu)

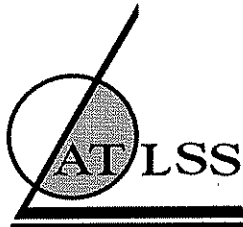

---

**DEVELOPMENT OF THE CHARACTERISTIC SECTION METHOD  
TO ESTIMATE THERMAL R-VALUES FOR PRECAST  
CONCRETE SANDWICH WALL PANELS**

by

**You-Jung Lee**  
Graduate Research Assistant  
Civil and Environmental Engineering

**Stephen Pessiki**  
Associate Professor  
Civil and Environmental Engineering

**ATLSS Report No. 03-06**

April 2003

**ATLSS is a National Center for Engineering Research  
on Advanced Technology for Large Structural Systems**

117 ATLSS Drive  
Bethlehem, PA 18015-4729

Phone: (610)758-3525  
Fax: (610)758-5902

[www.atlss.lehigh.edu](http://www.atlss.lehigh.edu)  
Email: [inatl@lehigh.edu](mailto:inatl@lehigh.edu)

## **ACKNOWLEDGMENTS**

This research was funded by the Precast/Prestressed Concrete Institute. Additional financial and technical support was provided by Metromont Prestress Company, Owens-Corning Corporation, and the Tindall Corporation. The support from the sponsors is gratefully acknowledged. This findings and opinions expressed in this report are those of the authors.

# TABLE OF CONTENTS

	Page
LIST OF TABLES	v
LIST OF FIGURES	vi
ABSTRACT	1
<u>CHAPTER 1: INTRODUCTION</u>	
1.1. INTRODUCTION	2
1.2. OBJECTIVES	3
1.3. OUTLINE OF REPORT	3
<u>CHAPTER 2: BACKGROUND</u>	
2.1. INTRODUCTION	4
2.2. GENERAL INFORMATION	4
2.2.1. Terminology and Units	4
2.2.2. Notation	5
2.2.3. Fundamental Equations	6
2.3. PRESTRESSED PRECAST CONCRETE SANDWICH WALL PANELS	7
2.4. CLASSICAL CALCULATION METHODS	7
2.4.1. Parallel Flow Method	7
2.4.2. Isothermal Plane Method	8
2.4.3. Zone Method	9
2.5. PHYSICAL TEST METHODS	9
2.5.1. Guarded Hot Box Method (ASTM C236)	10
2.6. FINITE ELEMENT METHOD	10
<u>CHAPTER 3: COMPARISON OF CLASSICAL CALCULATION METHODS AND FINITE ELEMENT METHOD APPROACH TO DETERMINE R-VALUES</u>	
3.1. INTRODUCTION	21
3.2. DESCRIPTION OF EXAMPLE	21
3.3. CLASSICAL CALCULATION METHODS	21
3.3.1. Parallel Flow Method	21
3.3.2. Isothermal Plane Method	22
3.4. FINITE ELEMENT METHOD CALCULATIONS	22
3.5. COMPARISON OF CLASSICAL CALCULATION AND F.E.M.	23
<u>CHAPTER 4: DEVELOPMENT OF THE CHARACTERISTIC SECTION METHOD</u>	
4.1. INTRODUCTION	34
4.2. DEFINITION OF THE CHARACTERISTIC SECTION	34
4.3. HEAT TRANSFER THROUGH THE CHARACTERISTIC SECTION	35

4.3.1. Insulation Thickness	35
4.3.2. Concrete Thickness	36
4.3.3. Width of Solid Concrete Region	36
4.4. DESCRIPTION OF THE CHARACTERISTIC SECTION METHOD	37
4.4.1. Overview	37
4.4.2. Example R-value Calculations	39
4.5 DEVELOPMENT OF EQUATIONS FOR WIDTH OF EFFECTED ZONE	48
4.5.1. Symmetric Cases	48
4.5.2. Unsymmetric Cases	49
4.5.3. Material Conductivities	49
4.6. APPLICATION OF THE CHARACTERISTIC SECTION METHOD TO FULL PANELS	50
4.6.1. Symmetric Panels	50
4.6.2. Unsymmetric Panels	51
4.6.3. Panels with Different Material Conductivities	51
<u>CHAPTER 5: SUMMARY AND FUTURE RESEARCH</u>	
5.1. SUMMARY	71
5.2. Future research	72
REFERENCES	73

## LIST OF TABLES

		Page
CHAPTER 4		
Table 4.1	Variation in $E_z$ with concrete wythe thickness and insulation layer thickness for symmetric characteristic sections.	52
Table 4.2	Variation in $E_z$ with concrete wythe thickness for unsymmetrical characteristic sections.	52
Table 4.3	Variation in $E_z$ with concrete and insulation thermal conductivities for a 3-2-3-24 characteristic section.	53
Table 4.4	R-values computed using the finite element method and the characteristic section method for the panel shown in Figure 4.13.	54
Table 4.5	R-values computed using the finite element method and the characteristic section method for the panels in Figure 4.15.	55

## LIST OF FIGURES

	Page
<b>CHAPTER 2</b>	
Figure 2.1	12
Figure 2.2	13
Figure 2.3	14
Figure 2.4	15
Figure 2.5	16
Figure 2.6	17
Figure 2.7	18
Figure 2.8	19
Figure 2.9	20
 <b>CHAPTER 3</b>	
Figure 3.1	24
Figure 3.2	25
Figure 3.3	27
Figure 3.4	28
Figure 3.5	30
Figure 3.6	31
Figure 3.7	32
Figure 3.8	33
 <b>CHAPTER 4</b>	
Figure 4.1	56
Figure 4.2	57
Figure 4.3	58
Figure 4.4	58
Figure 4.5	59
Figure 4.6	60
Figure 4.7	61
Figure 4.8	62
Figure 4.9	63
Figure 4.10	64
Figure 4.11	65
Figure 4.12	66
Figure 4.13	67



Figure 4.14	Typical precast concrete sandwich wall panel showing solid concrete zones increased by $E_z$ .	68
Figure 4.15	Typical precast concrete sandwich wall panels which are symmetric through the thickness.	69
Figure 4.16	Typical precast concrete sandwich wall panel showing solid concrete zones increased by $E_z$ .	70

## ABSTRACT

Precast concrete sandwich wall panels are used as exterior walls for many types of structures. These panels generally span vertically between foundations and floors or roofs, and provide the dual function of transferring wind load and providing thermal insulation for the structure. Sandwich wall panels are commonly composed of two concrete wythes separated by a layer of insulation. They often include solid concrete regions that extend through the entire thickness of the panel to place inserts for lifting and handling, and also to place hardware for connections to the foundation and adjacent panels. These solid concrete regions create thermal bridges which reduce the overall effectiveness of the insulation.

Present methods to estimate the thermal resistance, or R-value, of a sandwich panel include classical calculations methods such as the parallel flow and isothermal plane methods, physical tests, and finite element methods. The parallel flow and isothermal plane methods are shown to provide inaccurate results for sandwich wall panels. Physical tests to determine R-values are expensive to perform. Finite element methods can be cumbersome for routine use in design with currently available software.

A new simplified calculation method, called the Characteristic Section Method, is proposed to estimate R-values for precast concrete sandwich wall panels. The method was developed by studying the heat transfer through the characteristic section in a sandwich panel. The characteristic section is an assemblage of concrete and insulation in a geometrical configuration that occurs repeatedly throughout typical sandwich wall panels.

In the proposed Characteristic Section Method, the panel is divided in to two regions. The first region is treated as a perfectly insulated panel without any thermal bridge. The second region is treated as a solid concrete panel without any insulation. The total thermal resistance of the panel is calculated as the resistances of these two regions added together in parallel. The portion of the panel that is treated as a solid concrete panel without any insulation is larger than the actual solid concrete regions that exist in the panel. There is an effected zone around each solid concrete region that is added to the actual area of the solid concrete region to obtain the size of the concrete region used in the calculation. Equations are developed to compute the width of the effected zone as a function of the thicknesses of the face wythe, back wythe, and insulation layer, and also as a function of the thermal conductivities of the concrete and insulation.

# CHAPTER 1 INTRODUCTION

## 1.1 INTRODUCTION

Precast concrete sandwich wall panels are widely used in present construction because of the desirable characteristics of these panels such as durability, economy, fire resistance, large vertical spaces between supports, and superior energy performance as compared to many other wall systems.

Sandwich wall panels are used as exterior walls for many types of structures. These panels generally span vertically between foundations and floors or roofs to provide the permanent wall system, but may also span horizontally between columns. The panels provide the dual function of transferring wind load and providing thermal insulation for the structure.

Sandwich wall panels are commonly composed of two concrete wythes separated by a layer of insulation. Often, both concrete wythes are built with uniform thicknesses, but a structural shape such as a hollow core slab or double tee beam is sometimes used in place of one of the concrete wythes.

Sandwich wall panels often include solid concrete regions that extend through the entire thickness of the panel. These solid concrete regions are used to place inserts for lifting and handling, and also to place hardware for connections to the foundation and adjacent panels. Wythe connectors that pass through the insulation layer are used to connect the two concrete wythes. These wythe connectors keep the panel intact during handling and service conditions, and in some instances may be used to provide composite action. Both the solid concrete regions and the wythe connectors interrupt the continuous insulation layer. These interruptions are called thermal bridges. The overall effectiveness of the insulation reduces relative to the amounts and types of different materials that comprise the thermal bridges.

The thermal resistance, or R-value, represents the thermal performance of a precast concrete sandwich wall panel. To develop an accurate R-value calculation method for R-values for sandwich wall panels, the parallel flow and isothermal plane calculation methods are studied first. These methods are the classical calculation methods which are sometimes used to estimate thermal properties for the composite walls. At present, only these classical calculation methods are practical for routine use in design. However, the thermal properties that are calculated by these methods are not accurate for precast concrete sandwich wall panels with interruptions by thermal bridges as described above. The finite element method is another method of analysis that can be used to evaluate the thermal performance of sandwich panels. In short, the finite element method can be used to model physical tests that are used to measure R-values. However, application of the finite element in routine design would be cumbersome with currently available software. In this research, the finite element method is used as a tool to develop an accurate and simplified method to

calculate R-value for precast concrete sandwich wall panels that is suitable for use in design.

## **1.2 OBJECTIVES**

The objective of this research is to develop a simplified calculation method to estimate the R-values of precast concrete sandwich wall panels.

## **1.3 OUTLINE OF REPORT**

The remainder of this report is separated into four chapters. Chapter 2 provides background information, including a further description of precast sandwich wall panels, and a review of the classical calculation methods, experimental methods, and the finite element methods that can be used to estimate R-values. The details of the classical calculation methods are explained further in Chapter 3, and an example that compares these methods to the finite element method is presented. Chapter 4 presents the new proposed simplified calculation method to estimate R-values which was developed in this research. Finally, Chapter 5 presents the conclusions of this research and recommendations for further research.

## CHAPTER 2 BACKGROUND

### 2.1 INTRODUCTION

This chapter provides background information related to this study. Section 2.2 presents general information such as terminology and units, notation, and fundamental equations relevant to this research. This information is adapted from various sources in the literature. Section 2.3 describes typical configurations of precast concrete sandwich wall panels. Section 2.4 reviews three classical calculation methods: the parallel flow and isothermal plane methods mentioned earlier, and also the zone method. Section 2.5 explains the physical test methods which can be used to estimate R-values and also which will be the basis of the finite element method analysis to determine R-values, and Section 2.6 describes details of the finite element method modeling.

### 2.2 GENERAL INFORMATION

#### 2.2.1 Terminology and Units

This section defines key terms used in this report, and provides the units associated with these terms. The definitions are taken from the Precast and Prestressed Concrete Design Handbook (PCI, 1999), Fundamentals of Heat and Mass Transfer (Incropera and DeWitt, 1996), and American Society of Heating, Refrigerating, and Air-Conditioning Engineers Handbook-Fundamentals (ASHRAE, 1993).

**British thermal unit (Btu)** – Approximately the amount of heat to raise one pound of water from 59 °F to 60 °F.

**Conduction** – The energy transfer that occurs across the medium, which may be a solid or a fluid. This is the term applied to the mechanism of internal energy exchange from one body to another, or from one part of body to another part, by the exchange of the kinetic energy of motion of the molecules.

**Conductivity, k (Btu-in/ hr-ft<sup>2</sup>·°F)** – The time rate of heat flow through a unit area of homogeneous material in a direction perpendicular to isothermal planes induced by a unit temperature gradient. Thermal conductivity must be evaluated for a specific mean temperature, because in most materials it varies with temperature.

**Convection** – Heat transfer that occurs between a surface and a moving fluid when they are at different temperatures. The fluid motion may be caused by external mechanical means (e.g., by a fan, pump, etc.), in which case the process is called forced convection. If the fluid motion is caused by density differences, which are created by the temperature differences existing in the fluid mass, the process is termed free convection or natural convection.

**Heat flux,  $q'$  (Btu/hr-ft<sup>2</sup>)** – The heat transfer rate per unit area perpendicular to the direction of transfer.

**Heat transfer** – Energy in transit due to a temperature difference.

**Heat transfer rate,  $q$  (Btu/hr)** – The flow of heat energy induced by a temperature difference. Heat may be transferred by conduction, mass transfer, convection, and radiation. These can occur separately or in combinations, depending on specific circumstances.

**Radiation** – Heat transfer in regions where a perfect vacuum exists as a result of a temperature difference. This is the term used to describe the electromagnetic radiation which has been observed to be emitted at the surface of a body which has been thermally excited.

**Thermal bridging** – The phenomenon associated with how heat moves through substances with different thermal conductivities. It indicates that heat takes the path of least resistance through these materials. When a layer of a panel consists of materials with different thermal conductivities, the heat flow tends to become attracted to the materials with higher conductivities and move laterally toward those materials.

**Thermal resistance, R-value (hr-ft<sup>2</sup>·°F/Btu)** – The ratio of a driving potential to the corresponding transfer rate. Under steady conditions, the mean temperature difference between two defined surfaces of material or construction that induces unit heat flow through a unit area.

**Thermal transmittance, U-factor (Btu/hr-ft<sup>2</sup>·°F)** – The time rate of heat flow per unit area under steady state conditions from the fluid on the warm side of a barrier to the fluids on the cold side, per unit temperature difference between the two fluids. It is evaluated by first evaluating the R-value and then computing its reciprocal, U. The U-factor is sometimes called the overall coefficient of heat transfer. In building practice, the heat transfer fluid is air. The temperature of the fluid is obtained by averaging its temperature over a finite region of fluid near the surface involved.

### 2.2.2 Notation

The following notation is used in this report:

$A_n$	=	area of each zone $n$
$A_p$	=	area of perfect panel zone
$A_s$	=	area of solid concrete zone
$A_t$	=	total area of panel
$A'$	=	portion of each zone
$A'_p$	=	portion of perfect panel zone
$A'_s$	=	portion of solid concrete zone
$d$	=	distance from panel surface to metal wythe connector

$E_z$	=	effected zone
$h$	=	convection coefficient
$h_b$	=	air convection coefficient of back side of wall
$h_c$	=	convection coefficient of cold air
$h_f$	=	air convection coefficient of face side of wall
$h_h$	=	convection coefficient of hot air
$k_n$	=	conductivity of material $n$
$k_{con}$	=	conductivity of concrete
$k'_{con}$	=	modified conductivity of concrete
$k_{in}$	=	conductivity of insulation
$k'_{in}$	=	modified conductivity of insulaiton
$m$	=	width or diameter of metal heat path terminal
$q_n$	=	heat transfer rate through a material $n$
$q'_n$	=	heat flux through a material $n$
$R_n$	=	thermal resistance through a material $n$
$R_{bn}$	=	thermal resistance of air on back side of wall
$R_{fn}$	=	thermal resistance of air on face side of wall
$R_p$	=	thermal resistance of perfect panel zone
$R_s$	=	thermal resistance of solid concrete zone
$t$	=	thickness of panel
$t_c$	=	thickness of concrete wythe
$t_{cb}$	=	thickness of back concrete wythe
$t_{cf}$	=	thickness of face concrete wythe
$t_i$	=	thickness of insulation layer
$T_{mn}$	=	interface temperature between two materials $m$ and $n$
$T_1$	=	surface temperature of the cold side of test panel
$T_2$	=	surface temperature of the warm side of test panel
$T_b$	=	air temperature of back of sandwich panel
$T_c$	=	air temperature of cold side of sandwich panel
$T_f$	=	air temperature of face of sandwich panel
$T_h$	=	air temperature of hot side of sandwich panel
$U$	=	thermal transmittance
$w$	=	width of metal zone
$w_s$	=	width of solid concrete region
$W$	=	total width of panel
$\Delta T$	=	temperature difference
$\alpha$	=	insulation conductivity coefficient factor
$\beta$	=	concrete conductivity coefficient factor

### 2.2.3 Fundamental Equations

$$q = \frac{\Delta T \cdot A}{R} \quad (2.1)$$

$$q = -h \cdot \Delta T \quad (2.2)$$

$$q' = \frac{\Delta T}{R} \quad (2.3)$$

$$R = \frac{t}{k \cdot A'} \quad (2.4)$$

### 2.3 PRESTRESSED PRECAST CONCRETE SANDWICH WALL PANELS

Prestressed precast concrete sandwich wall panels are composed of two concrete wythes with a layer of insulation between the two concrete wythes. These types of wall panels are typically comprised of structural concrete, reinforcing bars, mesh, embedded steel hardware, prestressing strands, insulation of various types, and a variety of wythe connectors. Figure 2.1 shows three typical configurations of precast concrete sandwich wall panels. The solid concrete regions where the insulation is omitted in each panel are shown as dashed lines.

Figure 2.2 shows some detailed examples of solid concrete usages to place hardware for connections. Figure 2.2(a) shows a connection region between the vertical wall and the foundation. Figure 2.2(b) shows a region of vertical wall and horizontal span connection. Because sandwich wall panels contain solid concrete regions, these panels have less thermal resistance than sandwich wall panels with no thermal bridges. Metal wythe connectors also create thermal bridges. However, metal wythe connectors do not have as much of an effect on the thermal resistance of the panel as compared to the solid concrete regions for typical sandwich wall panels. Thus, in this research, the effect of metal wythe connectors is not considered, and attention is focused on thermal bridges created by regions of solid concrete.

### 2.4 CLASSICAL CALCULATION METHODS

Classical R-value calculation methods, which are used to estimate the R-values of wall assemblages comprised of more than one material, are presented in the American Society of Heating, Refrigerating and Air-Conditioning Engineers Handbook-Fundamentals (ASHRAE, 1993), hereafter referred to as the ASHRAE Handbook. There are three classical calculation methods: parallel flow method; isothermal plane method; and, zone method. All three methods are based on electric circuit analogies. The following is a general description of each method.

#### 2.4.1 Parallel Flow Method

The parallel flow method deals with the thermal resistance of a layer that consists of two or more materials with different thermal conductivities. Figure 2.3 shows the parallel flow method with a simple example. Figure 2.3(a) is a cross section of a composite panel. The panel is assembled with different materials: two exterior layers and one interior layer which consists of two materials with different thermal conductivities. Figure 2.3(b) shows the configuration of the parallel flow method represented by parallel electric circuits.



Basically, the parallel flow method assumes that heat flows in only one direction, and surfaces parallel to the heat flow direction are adiabatic. In other words, the parallel flow method assumes that the heat that flows through an assemblage of materials flows in parallel paths of different thermal conductivities, and there is no lateral heat flow between paths. According to this assumption, the R-value for composite panels like Figure 2.3(a) can be calculated by considering each independent heat flow path and its resistance. The equation in Figure 2.3(c) is the equation to estimate R-value based upon the parallel flow method. In addition, the thermal resistances of the air on the two exterior surfaces of the panel,  $R_b$  and  $R_f$ , are also components of the individual heat resistances.

The parallel flow method can be used to calculate other thermal properties as well. Using the relationship between the thermal resistance and heat flux,  $q'$ , defined in Equation 2.3, the heat flux can be calculated with known temperature differences and the area portions of each path. As a result, the total heat transfer rate becomes the sum of the heat transfer rate of both paths. Since the thermal resistance and heat transfer rate of individual materials are calculated, the temperature of each surface can be calculated as well. The details of these calculations are presented in an example in Chapter 3 for a specific assemblage of materials.

#### **2.4.2 Isothermal Plane Method**

The isothermal plane method is used to calculate the total thermal resistance of two or more layers of a material when each layer contains only one material or each layer contains different materials that have the same thermal conductivity. The isothermal plane method assumes that heat flows laterally on any continuous layer so that transverse isothermal planes result.

Figure 2.4 shows the isothermal plane method with the same assemblage that was used to explain the parallel flow method. Figure 2.4(a) is the cross-section of the composite panel, and Figure 2.4(b) shows the electric circuit representation of the isothermal plane method.

The main assumption of the isothermal plane method is that surfaces normal to the heat flow direction are isothermal. According to this assumption, the R-value can be calculated by using the equation in Figure 2.4(c). The total resistance,  $R$ , of the combined layers is the numerical sum of the resistances of all parts of the construction in series. Thus, the R-value is a serial combination of layers, in which the resistance of each layer is calculated by the parallel flow method.

Using the relationship between the thermal resistance and heat flux (Equation 2.3), the heat flux can be calculated. For a layer which has materials with two different conductivities, the sum of the heat transfer for each path is the same as other layers. In other words, the heat flux through each layer is the same. The details of these calculations are also presented in Chapter 3 for a specific assemblage of materials.

### 2.4.3 Zone Method

The zone method reportedly can be used for structures with widely spaced metal connectors of a substantial cross-sectional area. The zone method is presented in the ASHRAE Handbook. This method involves two separate calculations: one for a chosen limited portion, Zone A, containing the highly conductive element such as a metal wythe connector, and the other for the remaining portion of the simpler construction of Zone B. The two computations are then combined using the parallel flow method, and the average transmittance per unit area is calculated.

More details of the zone method, taken from the ASHRAE Handbook follow. Figure 2.5 shows the separations of two zones: Zone A and Zone B. The area of the two zones is determined by Equation 2.5. As shown in Equation 2.5, the surface area of Zone A is determined by the metal elements, and Zone B is the rest of area. The width of Zone A,  $w$ , is calculated from Equation 2.5, and the value of  $d$  should not be less than 0.5 in. for still air.

$$w = m + 2 \cdot d \quad (2.5)$$

where

$m$  = width or diameter of metal heat path terminal, in.

$d$  = distance from panel surface to metal, in.

For example, the composite wall panel with a metal wythe connector, such as in Figure 2.6, reveals the electric circuit based on the zone method. In fact, Zone A is the width of the effected zone in Figure 2.6. The electric circuit for Zone A is based on the isothermal plane method and Zone B is based on either one of the classical calculation methods. The two paths are then combined parallel with the areas of Zone A and Zone B respectively, which are calculated by the Equation 2.5. Equation 2.6 shows the equation for estimating the R-value.

$$\frac{1}{R} = \frac{A_1}{R_1} + \frac{A_2}{R_2} \quad (2.6)$$

The ratio of area for Zone A is  $A_1$ , and the ratio of area for Zone B is  $A_2$ . Also, the individual thermal resistances are  $R_1$  and  $R_2$  for Zone A and Zone B, respectively.

## 2.5 PHYSICAL TEST METHODS

Physical tests are another way to determine R-values, and several ASTM Standard Test Methods exist for this purpose. Out of several ASTM tests, there are two hot box methods (ASTM C236 and ASTM C976) which are used for building components. The two hot box methods are the guarded hot box method and the calibrated hot box method. The guarded hot box method is used to measure steady-state thermal properties of panels, and the calibrated hot box method is more satisfactory for testing assemblages under dynamic conditions (nonsteady-state).

Consequently, the guarded hot box method is the general thermal performance test for sandwich wall panels, and it is modeled using finite element method of analysis in this research. Details of this test method are given below.

### **2.5.1 Guarded Hot Box Method (ASTM C236)**

The guarded hot box method covers the measurement of the steady-state thermal transfer properties of panels. This method is applicable for building construction assemblies, building panels, and other applications of homogeneous and nonhomogeneous materials at similar temperature ranges.

Figure 2.7 shows a schematic arrangement of the major components of the guarded-hot-box test system. The left side of the box contains cold air. The other side of the box is the guarded box which contains hot air. These two boxes are separated by a test panel. The hot box is an apparatus designed to determine thermal performance for representative test panels and is an arrangement for establishing and maintaining a desired steady temperature difference across a test panel for the period of time necessary to ensure constant heat flux and steady temperature.

Figure 2.8 provides more detail about the arrangement of equipment during the test. In the warm side of the box, there is a metering box which makes the resistance of the box wall uniform over the entire box area. The cold air-side has a fan to force air downward through the enclosed refrigeration coils and upward through the space between a baffle and the test panel. Data to be determined include the total net energy or average power through the specimen during a measurement interval which includes all meter box heating and power to fans for blowers, and any corrections for meter box wall heat flow. The area and the temperatures are measured directly. The data includes all air and surface temperatures and the effective dimensions of the metered area. In addition, the data results are the average data for the two or more successive 4-hour periods that agree within 1%.

## **2.6 FINITE ELEMENT METHOD**

In this report, the finite element method is used to analyze problems of heat transfer. Specifically, the finite element method is used to model the guarded hot box test, and results of the analysis are used to compute R-values for various assemblies.

Figure 2.9 shows how the finite element method is used to model the guarded hot box test. Note that the model in Figure 2.9 is a typical 2D model case. This research uses 2D models first to understand the heat flow through the sandwich panel, then later, 3D models have been conducted in advance. In Chapter 4, the 3D model studies will be discussed.

Figure 2.9(a) shows the test specimen to be modeled. The test specimen is subjected to a cold and hot side with temperatures  $T_c$  and  $T_h$  respectively. The cold side is subjected to forced convection with an air velocity of either 7.5 mph or 15 mph. The air velocity of 7.5 mph represents moving air for summer, and the 15 mph represents winter. The hot side is subjected to natural convection. Figure 2.9(b) shows the 2D finite element model that is based on the guarded hot box test. The boundary conditions are steady-state conditions and adiabatic in the z-direction (i.e. out of the plane of the figure). In this model, two different elements are used. Shell elements are used to model the panel materials, and frame elements are used to model the convection of the surfaces.

The shell element is for modeling heat transfer in thin-walled plates and shells arbitrarily located in two- and three-dimensional spaces. Isotropic material properties are used as constants throughout the element. The frame element is for modeling heat transfer in rods or beams arbitrarily located in one-, two- and three-dimensional spaces.

The output from the heat transfer finite element analysis represents the heat transfer rates in each joint or element. The R-value is calculated using Equation 2.1, since the air temperature difference across the test specimen and the area of the specimen are also known. Numerous R-value results are presented in the following chapters. These R-value results are based on the finite element analyses, and are calculated using Equation 2.1 and the heat transfer rates obtained from the analyses.

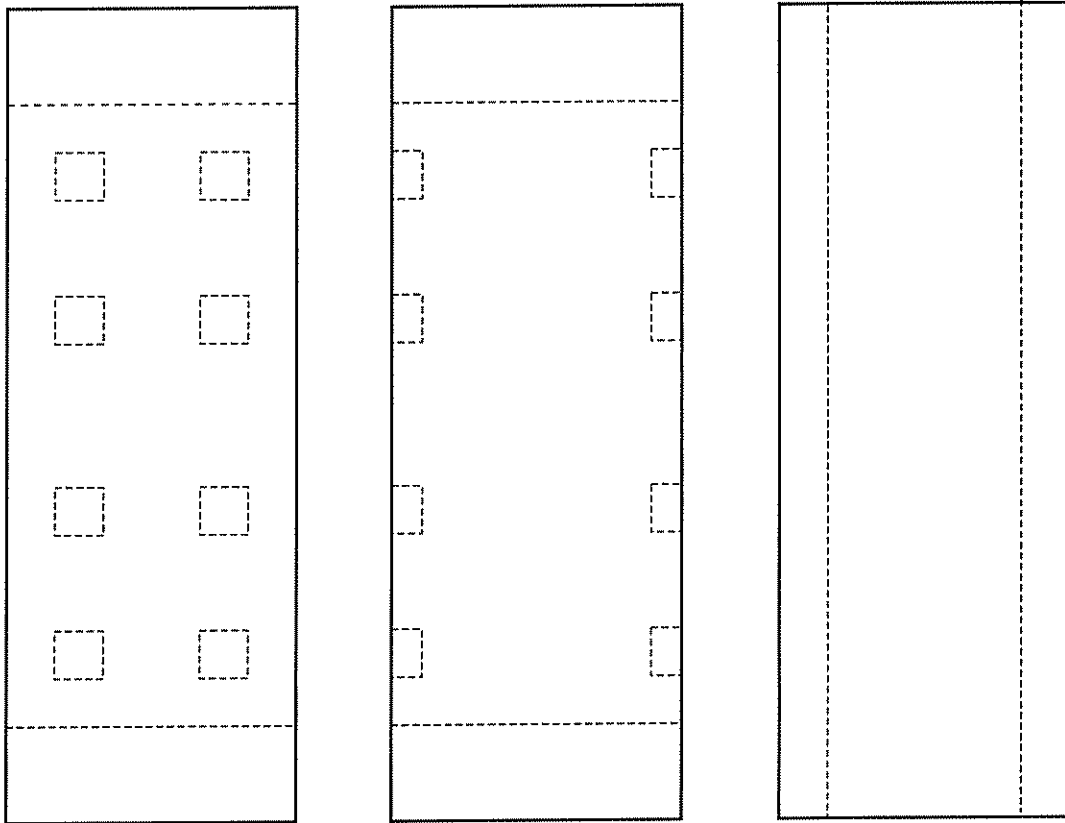

Figure 2.1 Three typical configurations of precast concrete sandwich wall panels.

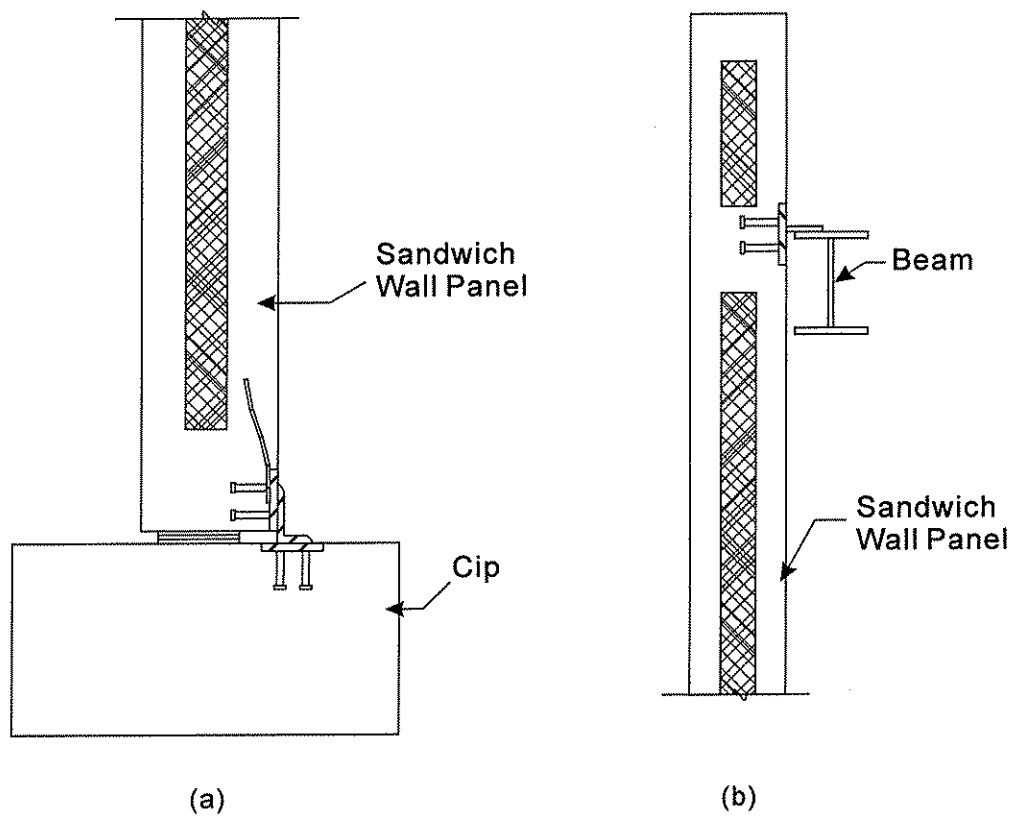
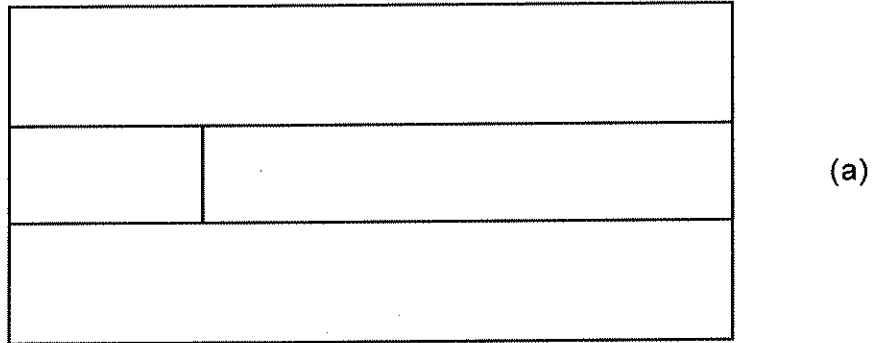
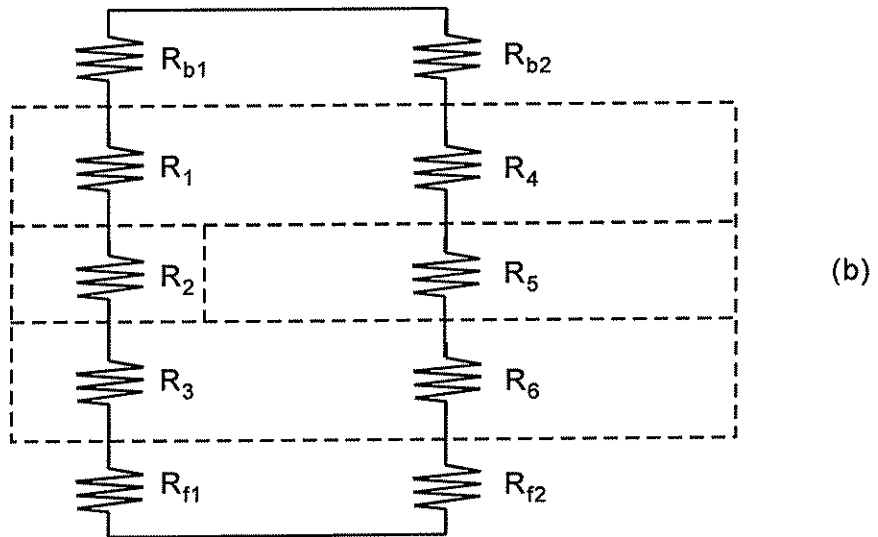

Figure 2.2 Example solid concrete connection regions: (a) connection between the vertical wall and foundation; (b) connection between vertical wall and horizontal span.



(a)



(b)

$$\frac{1}{R} = \frac{1}{R_{b1} + R_1 + R_2 + R_3 + R_{f1}} + \frac{1}{R_{b2} + R_4 + R_5 + R_6 + R_{f2}} \quad (c)$$

Figure 2.3 Parallel flow method (parallel circuit): (a) assemblage of materials; (b) electric circuit analogy; (c) equation to estimate R-value using the parallel flow method.

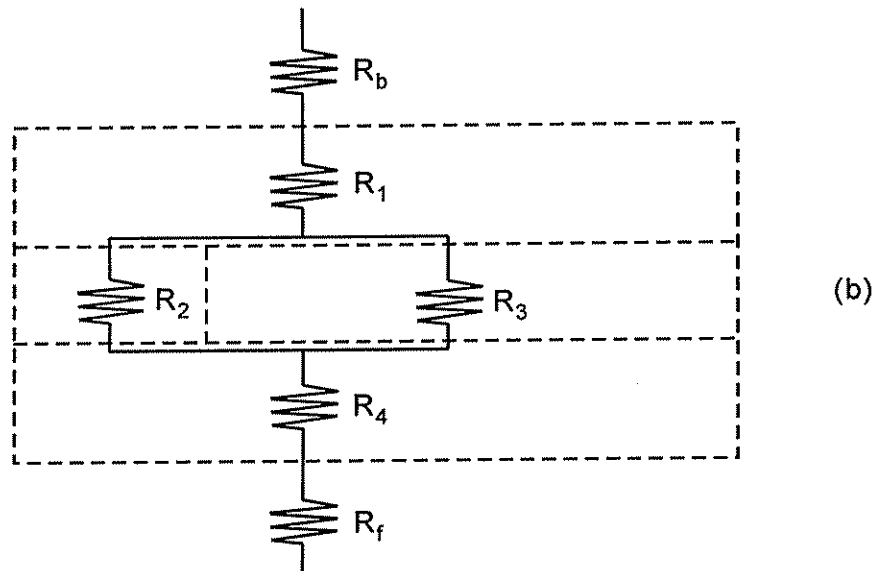
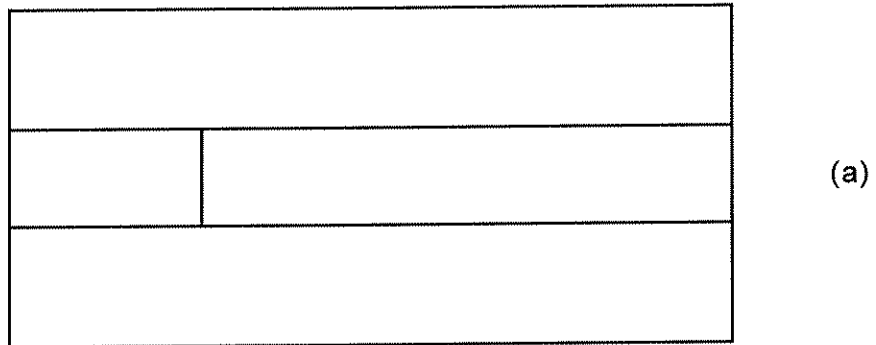

$$R = R_b + R_1 + \frac{1}{\frac{1}{R_2} + \frac{1}{R_3}} + R_4 + R_f \quad (c)$$

Figure 2.4 Isothermal plane method (serial circuit): (a) assemblage of materials; (b) electric circuit analogy; (c) equation to estimate R-value using the isothermal plane method.



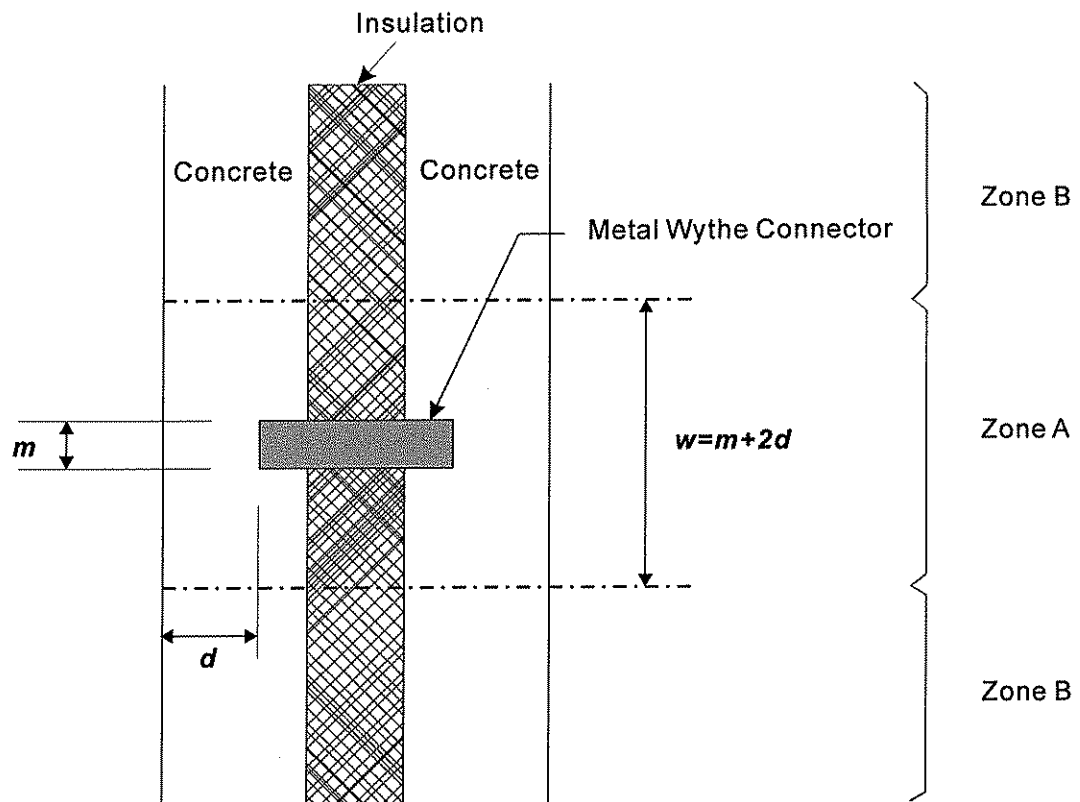

Figure 2.5 The determination of the width of the zone based on the zone method.

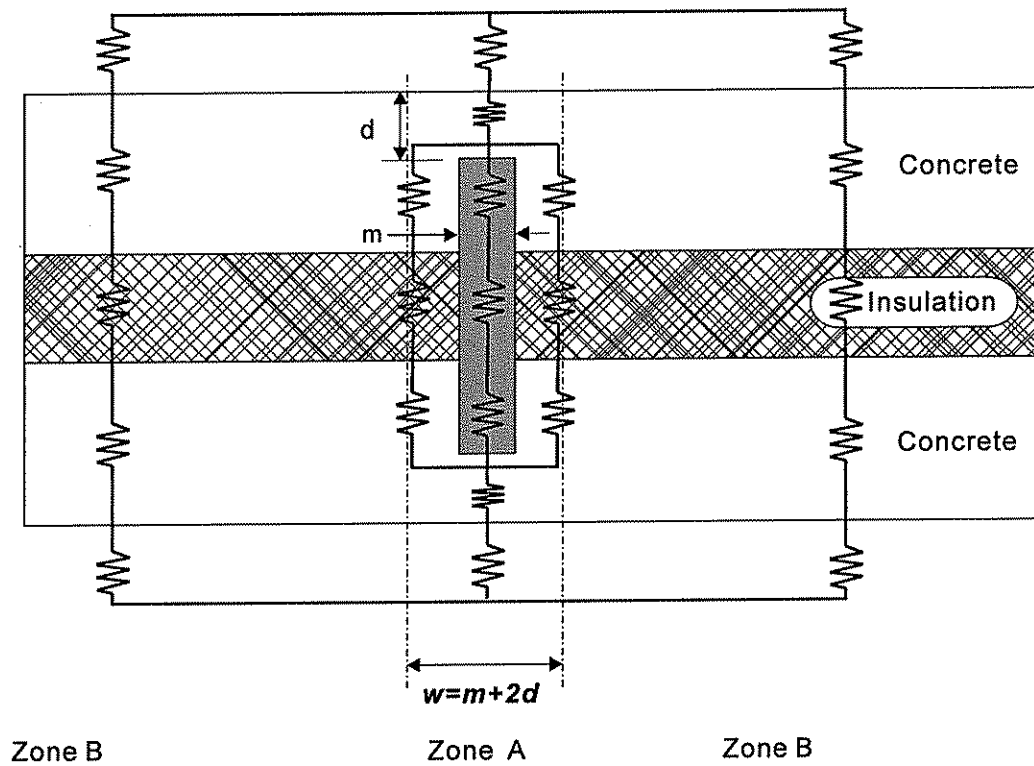

Figure 2.6 The electric circuit based on the zone method.

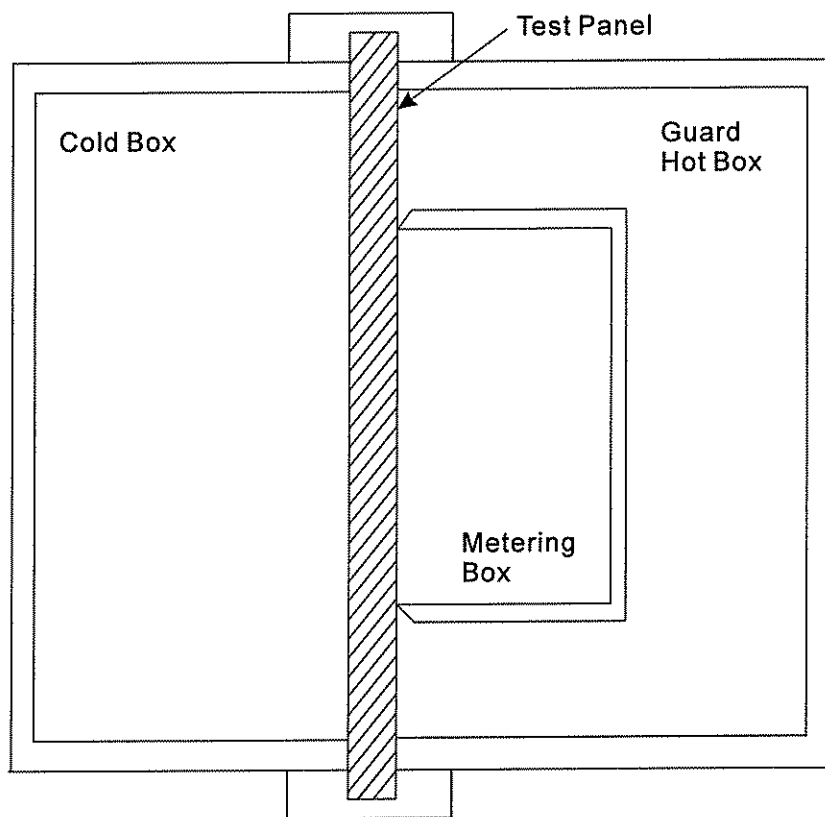

Figure 2.7 Schematic arrangement of the major components of the guarded hot box test (ASTM C236).

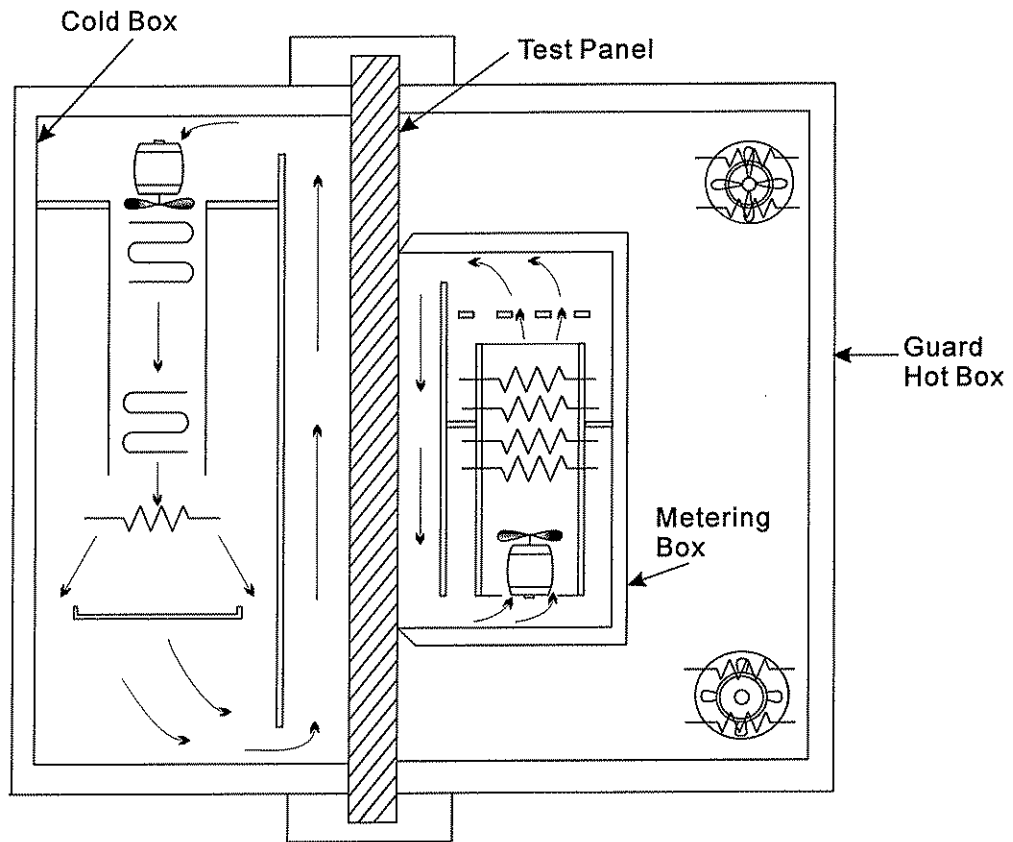

Figure 2.8 Detailed arrangement of equipment in guarded hot box test (ASTM C236).

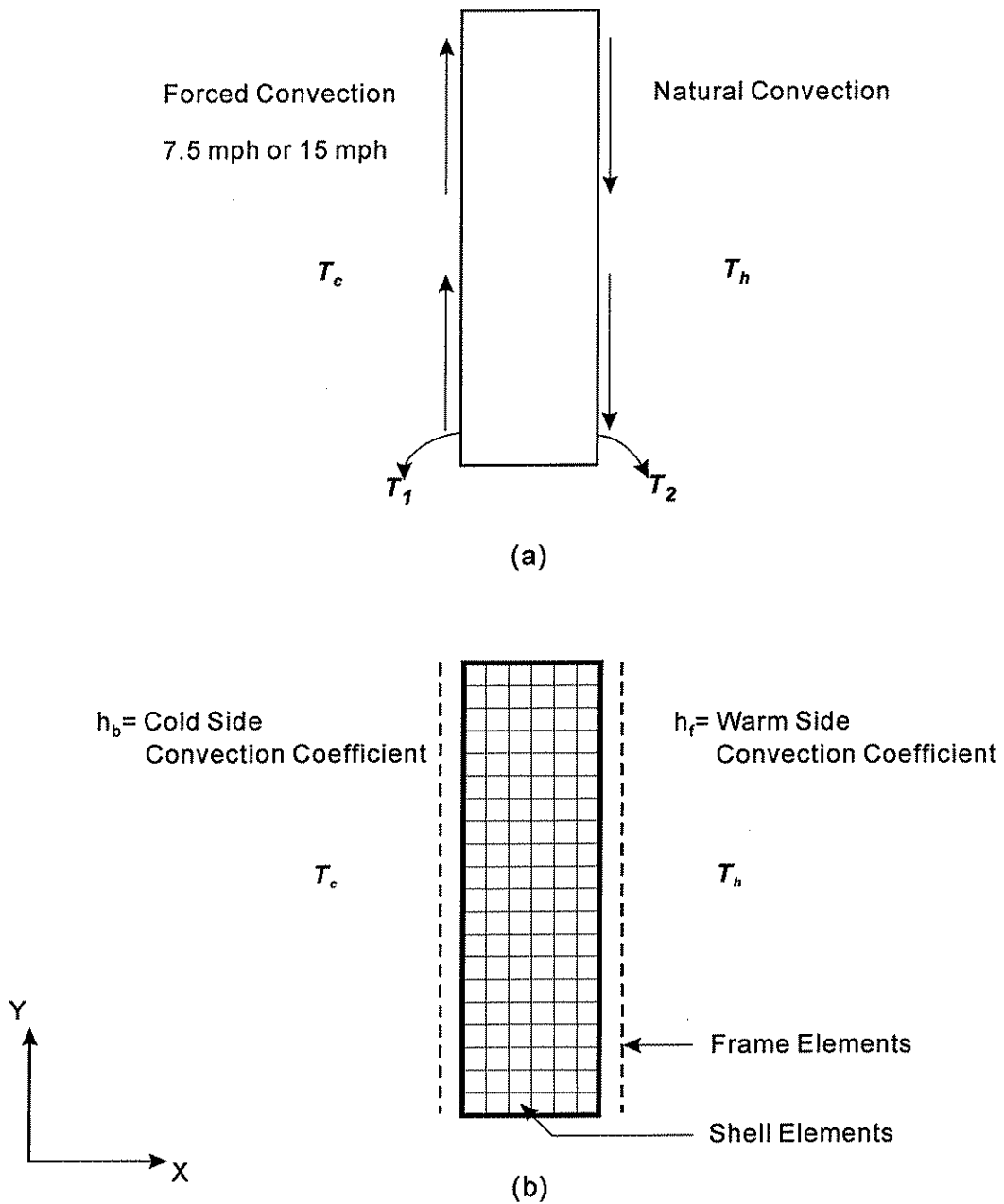

Figure 2.9 Finite element modeling of guarded hot box test (2D): (a) actual test assembly; (b) finite element model.

## CHAPTER 3 COMPARISON OF CLASSICAL CALCULATION METHODS AND FINITE ELEMENT METHOD APPROACH TO DETERMINE R-VALUES

### 3.1 INTRODUCTION

This chapter compares R-value calculations performed using classical calculation methods and the finite element method. To explain and compare these different calculation methods, one specific assemblage of materials is selected, and calculations are performed using each method for this assemblage. Section 3.2 describes the assemblage of materials used to compare each calculation method. Section 3.3 discusses the calculations performed using the parallel flow and isothermal plane methods. The R-value calculation from the finite element method is discussed in Section 3.4. Then, in Section 3.5, the two classical calculation method results and the finite element method result are compared.

### 3.2 DESCRIPTION OF EXAMPLE

Figure 3.1 shows the geometry of the assemblage of materials selected to compare the different calculation methods. This assemblage has three layers and a unit thickness in the Z-direction. As shown in Figure 3.1, the middle layer contains two materials with two different conductivities. The conductivity for material 1 is  $k_1 = 12.05 \text{ Btu}\cdot\text{in}/\text{hr}\cdot\text{ft}^2\cdot^\circ\text{F}$ , which is a reasonable value for the thermal conductivity of concrete with a density of 150 pcf. The conductivity for material 2 is  $k_2 = 0.26 \text{ Btu}\cdot\text{in}/\text{hr}\cdot\text{ft}^2\cdot^\circ\text{F}$ , which is a reasonable value for the thermal conductivity of polystyrene insulation. The boundary conditions are steady-state conditions with the temperature on the back layer,  $T_b=25^\circ\text{F}$  and the temperature on the face layer,  $T_f=125^\circ\text{F}$ . The back layer has forced air convection, with a convection coefficient  $h_b=4.0 \text{ Btu}/\text{hr}\cdot\text{ft}^2\cdot^\circ\text{F}$ , and the face layer has free air convection, with a convection coefficient  $h_f=1.4 \text{ Btu}/\text{hr}\cdot\text{ft}^2\cdot^\circ\text{F}$ .

### 3.3 CLASSICAL CALCULATION METHODS

Three classical calculation methods were explained in Section 2.4: parallel flow, isothermal plane, and zone methods. However, because Equation 2.5 presented for the zone method only deals with widely spaced metal connectors, only the parallel flow and isothermal plane methods are treated here.

#### 3.3.1 Parallel Flow Method

Figure 3.2 shows the parallel flow method calculation for the assemblage of material shown in Figure 3.1. Figure 3.3 summarizes the results of the parallel flow method calculations.

The assemblage of materials is represented by resistances  $R_1$  through  $R_6$  and  $R_b$  and  $R_f$  along two separate paths. The subscript number or letter represents the assemblage of the material. For instance, the  $R_1$  denotes the thermal resistance of material 1. In addition, the resistances  $R_{b1}$ ,  $R_{f1}$ ,  $R_{b2}$ , and  $R_{f2}$  represent the thermal

resistances of the air on both faces and along both paths, as shown in Figure 3.2. The temperature at the interface of two layers is denoted as  $T_{ab}$ . For example, the  $T_{12}$  denotes the surface temperature between the two materials with resistances  $R_1$  and  $R_2$ . Each resistance is calculated from the geometry and thermal conductivities  $k_1$  and  $k_2$ . Equation 2.4 is used to calculate those resistances.

As shown in Figure 3.2(b), the heat flux is computed using Equation 2.3. This equation leads to a value of  $q'=36.75$  Btu/hr·ft<sup>2</sup>, which represents the sum of the heat transfer along Path 1 ( $q'_1=31.27$  Btu/hr·ft<sup>2</sup>) and Path 2 ( $q'_2=5.48$  Btu/hr·ft<sup>2</sup>). Lastly, Equation 2.3 is used to calculate the temperature at each interface in the assemblage. As shown in Figure 3.2(c), this calculation leads to temperature values of  $T_{f1}=82.16$  °F,  $T_{12}=66.59$  °F,  $T_{23}=56.21$  °F, and  $T_{3b}=40.64$  °F for Path 1, and  $T_{f4}=117.46$  °F,  $T_{45}=114.76$  °F,  $T_{56}=30.46$  °F, and  $T_{6b}=27.73$  °F for Path 2. This result checks with the temperature of the backside air which is 25 °F. These values are summarized in Figure 3.3. Solving the equivalent circuit leads to an R-value of 2.72 hr·ft<sup>2</sup>·°F/Btu, as shown in Figure 3.2(b).

### 3.3.2 Isothermal Plane Method

Figure 3.4 shows the isothermal plane method calculation for the same assemblage of materials shown in Figure 3.1. Figure 3.5 summarizes the results of the Isothermal plane method calculations.

The assemblage of materials is represented by resistances  $R_1$  through  $R_4$ , along two separate paths. These notations for thermal resistances and temperatures are similar to what was used for the parallel flow method calculations. Each resistance is calculated from the geometry and thermal conductivities  $k_1$  and  $k_2$  using Equation 2.4.

As shown in Figure 3.4, the heat flux is computed using Equation 2.3. This equation leads to a value of  $q'=56.89$  Btu/hr·ft<sup>2</sup>. This heat flux represents the sum of the heat transfer in Path 2 ( $q'_2=55.70$  Btu/hr·ft<sup>2</sup>) and Path 3 ( $q'_3=1.20$  Btu/hr·ft<sup>2</sup>). Again, Equation 2.3 is used to calculate the temperature at each interface in the assemblage. As shown in Figure 3.4, this calculation leads to temperature values of  $T_{f1}=86.03$  °F,  $T_{123}=71.87$  °F,  $T_{234}=53.38$  °F, and  $T_{4b}=39.22$  °F for each surface of layers, where  $T_{123}$  and  $T_{234}$  represent the interface temperature between the material resistance  $R_1$ ,  $R_2$  or  $R_3$ , and  $R_4$ , respectively, because the isothermal plane method assumes each layer contains the same temperature. These values are summarized in Figure 3.5. Solving the equivalent circuit leads to an R-value of 1.76 hr·ft<sup>2</sup>·°F/Btu, as shown in Figure 3.4(b).

### 3.4 FINITE ELEMENT METHOD CALCULATIONS

The assemblage of materials shown in Figure 3.1 was analyzed using the finite element method for the same assumptions used in the classical calculations described in Section 3.3. Not explicitly mentioned in Section 3.3, this includes the

assumption of two-dimensional behavior, so that surfaces perpendicular to the z-direction are adiabatic.

Figure 3.6 shows the finite element model of the assemblage shown in Figure 3.1. The heat transfer finite element analysis was performed using the Heat Transfer Analysis Module in the SAP 90 analysis program. The model is comprised of 1"x1" shell elements for the materials that comprise the assemblage, and frame elements for the surfaces that have either free or forced convection.

The output from the analysis includes the heat transfer rate and the temperature in each joint or element. Figures 3.7(b) and (c) show the heat transfer rate along the face of the assemblage. Figure 3.7(b) shows the heat transfer rate in the y-direction, i.e. parallel to the thickness direction, and Figure 3.7(c) shows the heat transfer rate in the x-direction, i.e. perpendicular to the thickness direction of the assemblage. Using these heat transfer rates, the R-value is calculated using Equation 2.5. The temperature distribution in the assemblage is illustrated in Figure 3.8. This contour is captured from the graphical results. This result clearly shows that the temperature in each layer is not uniform.

### **3.5 COMPARISON OF CLASSICAL CALCULATION METHODS AND THE FINITE ELEMENT METHOD**

The assemblage of materials shown in Figure 3.1 was analyzed with three different methods: parallel flow, isothermal plane, and the finite element methods. From this study, it is shown that the estimated thermal properties are different from different analyses.

First of all, the total thermal resistance values R vary somewhat between the different methods. The numerical result from the finite element method analysis is  $R=2.63 \text{ hr}\cdot\text{ft}^2\cdot^\circ\text{F}/\text{Btu}$ . However, the result from the parallel flow method is  $R=2.72 \text{ hr}\cdot\text{ft}^2\cdot^\circ\text{F}/\text{Btu}$ , and from the isothermal plane method is  $R=1.76 \text{ hr}\cdot\text{ft}^2\cdot^\circ\text{F}/\text{Btu}$ . The R-value from the parallel flow method is higher than the finite element method result, and the R-value from the isothermal plane method is lower than the finite element method result. The parallel flow method is the upper boundary, and the isothermal plane method is the lower boundary.

Secondly, the comparison of the heat flux for the three results shows a more clear view of the heat flow. Basically, the two classical calculation methods assume only one-dimensional heat flow. Figures 3.7(b) and 3.7(c) clearly show that the heat flow is two-dimensional.

Finally, the temperature distribution reveals another clear difference. As shown in Figures 3.7(d) the temperature distribution obtained by the finite element analysis is quite different from the results of the parallel flow method and the isothermal plane method analyses that are shown in Figure 3.3(c) and 3.5(c) respectively.



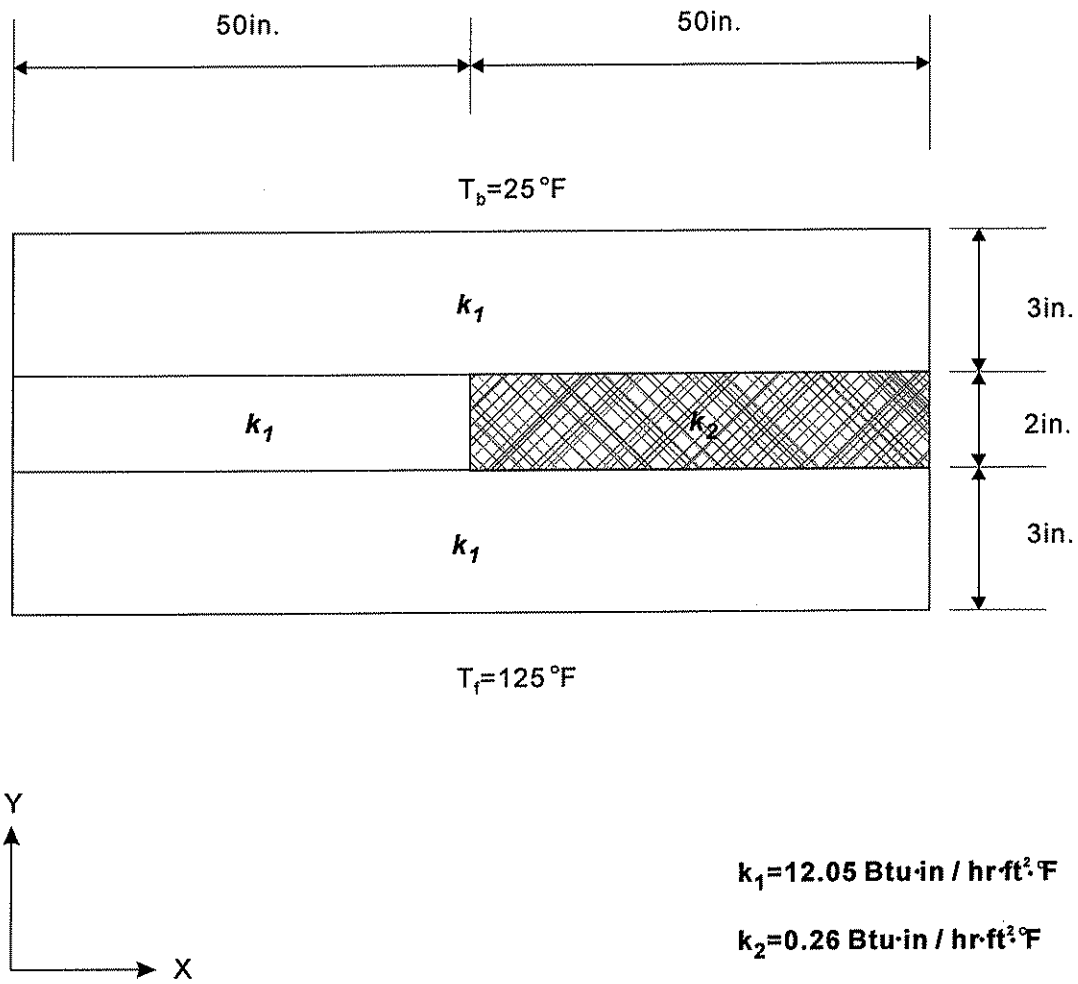
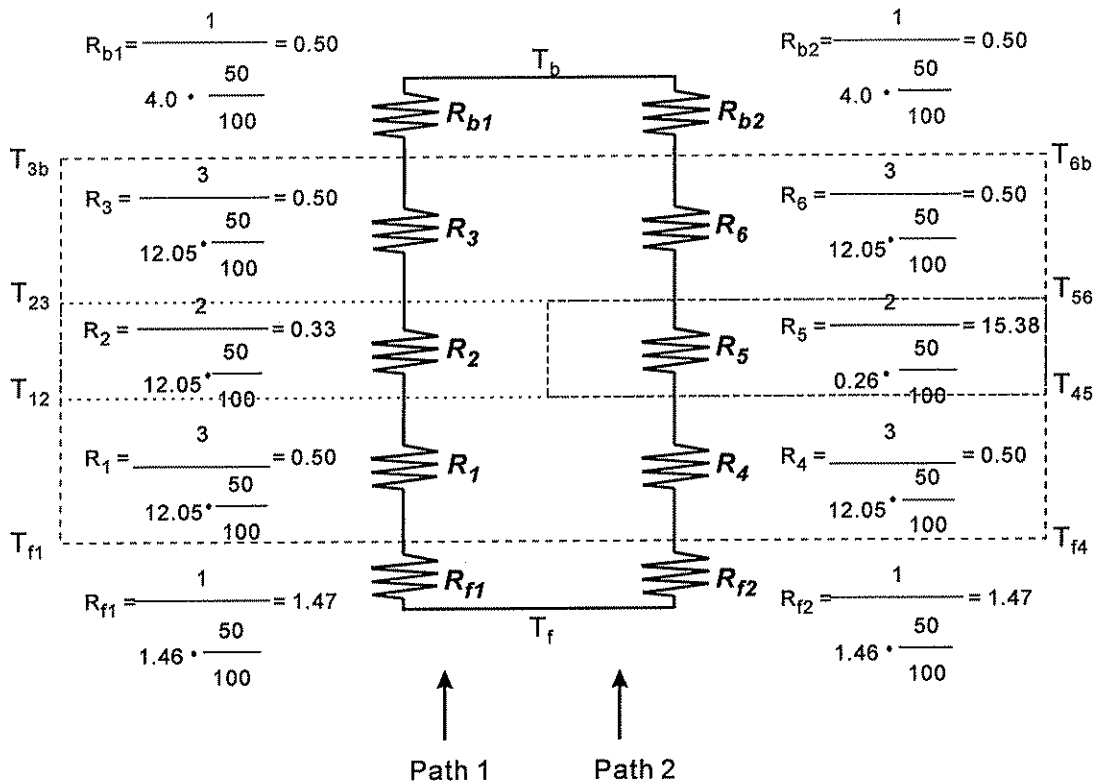

Figure 3.1 Example assemblage of materials used to compare classical calculation methods and finite element method.



(a)

R-value

$$R = \frac{1}{\frac{1}{R_{f1} + R_1 + R_2 + R_3 + R_{b1}} + \frac{1}{R_{f2} + R_4 + R_5 + R_6 + R_{b2}}} = 2.27 \text{ hr ft}^2\text{°F/ Btu}$$

Heat Flux

Total

$$q' = \frac{125 - 25}{R} = 36.752 \text{ Btu / hr ft}^2$$

(b)

Figure 3.2 Parallel flow method calculation for an example assemblage of material: (a) assemblage of material; (b) calculation of R-value (continued next page)

Path 1

$$q'_1 = \frac{125-25}{R_{f1}+R_1+R_2+R_3+R_{b1}} = 31.27$$

*Temperature of each surface*

$$q'_1 = \frac{125-T_{f1}}{R_{f1}}, \quad T_{f1} = 82.16$$

$$q'_1 = \frac{T_{f1}-T_{12}}{R_1}, \quad T_{12} = 66.59$$

$$q'_1 = \frac{T_{12}-T_{23}}{R_2}, \quad T_{23} = 56.21$$

$$q'_1 = \frac{T_{23}-T_{3b}}{R_3}, \quad T_{3b} = 40.64$$

$$q'_1 = \frac{T_{3b}-T_b}{R_{b1}}, \quad T_b = 25.00$$

Path 2

$$q'_2 = \frac{125-25}{R_{f2}+R_4+R_5+R_6+R_{b2}} = 6.11$$

*Temperature of each surface*

$$q'_2 = \frac{125-T_{f4}}{R_{f2}}, \quad T_{f4} = 117.46$$

$$q'_2 = \frac{T_{f4}-T_{45}}{R_4}, \quad T_{45} = 114.76$$

$$q'_2 = \frac{T_{45}-T_{56}}{R_5}, \quad T_{56} = 30.46$$

$$q'_2 = \frac{T_{56}-T_{6b}}{R_6}, \quad T_{6b} = 27.73$$

$$q'_2 = \frac{T_{6b}-T_b}{R_{b2}}, \quad T_b = 24.99$$

(c)

Figure 3.2 (continued) Parallel flow method calculation for an example assemblage of material: (c) calculation of heat flux and temperature of each wythe.

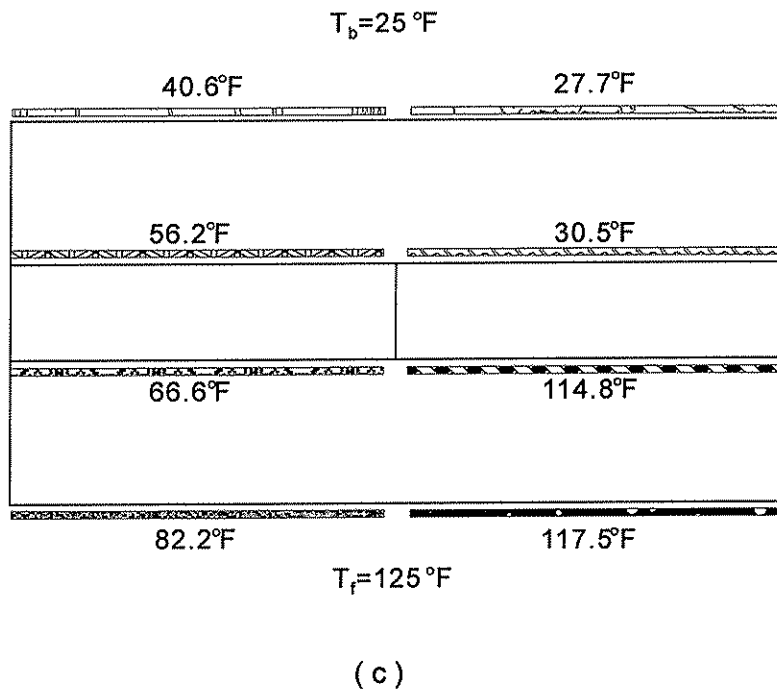
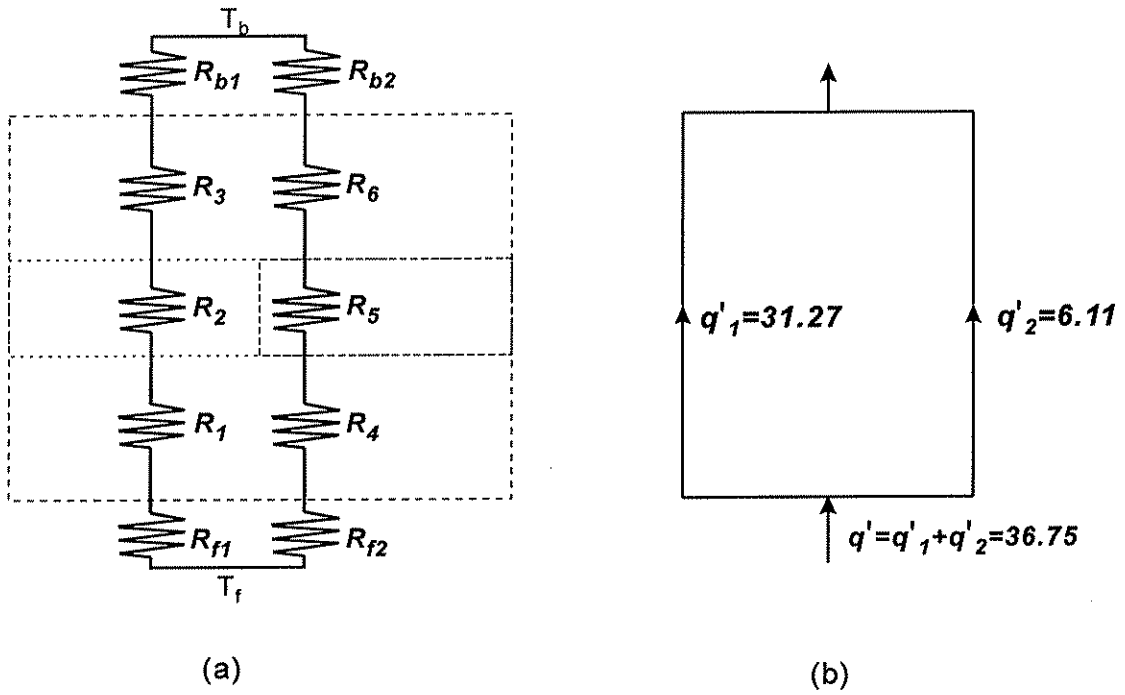
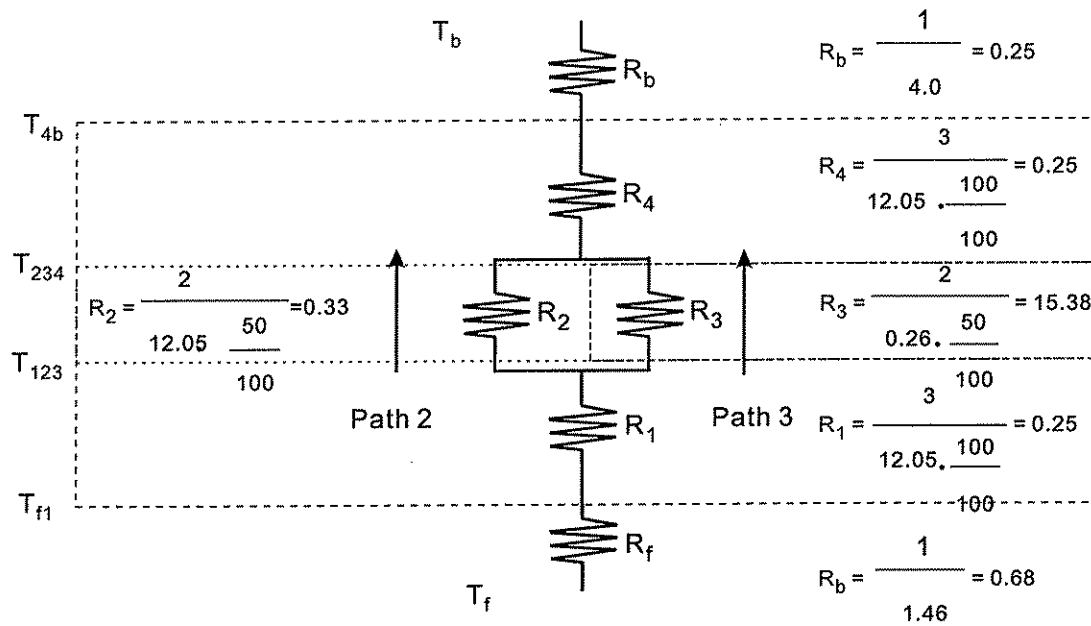

Figure 3.3 Summary of parallel flow calculations results: (a) thermal resistance; (b) heat flux; (c) temperature distribution.



(a)

R-value 
$$R = R_b + R_1 + \frac{1}{\frac{1}{R_2} + \frac{1}{R_3}} + R_4 + R_f = 1.758$$

Heat flux

Total 
$$q' = \frac{125-25}{R} = 56.889$$

(b)

Figure 3.4 Isothermal plane method calculation for the assemblage of material: (a) assemblage of material ; (b) calculation of R-value (continued next page).

Temperature of each surface

$$q' = \frac{125 - T_{f1}}{R_f}, \quad T_{f1} = 86.03$$

$$q' = \frac{T_{f1} - T_{123}}{R_1}, \quad T_{123} = 71.87$$

$$q' = \frac{T_{123} - T_{234}}{\frac{1}{\frac{1}{R_2} + \frac{1}{R_3}}}, \quad T_{234} = 53.38$$

$$q' = \frac{T_{234} - T_{4b}}{R_4}, \quad T_{4b} = 39.22$$

$$q' = \frac{T_{4b} - T_b}{R_b}, \quad T_b = 25.00$$

Heat flux

$$q'_2 = \frac{T_{123} - T_{234}}{R_2} = 55.70$$

$$q'_3 = \frac{T_{123} - T_{234}}{R_3} = 1.20$$

Check  $q'_2 + q'_3 = 56.90$

(c)

Figure 3.4 (Continued) Isothermal planemethod calculation for the assemblage of material: (c) calculation of heat flux and temperature of each wythe.

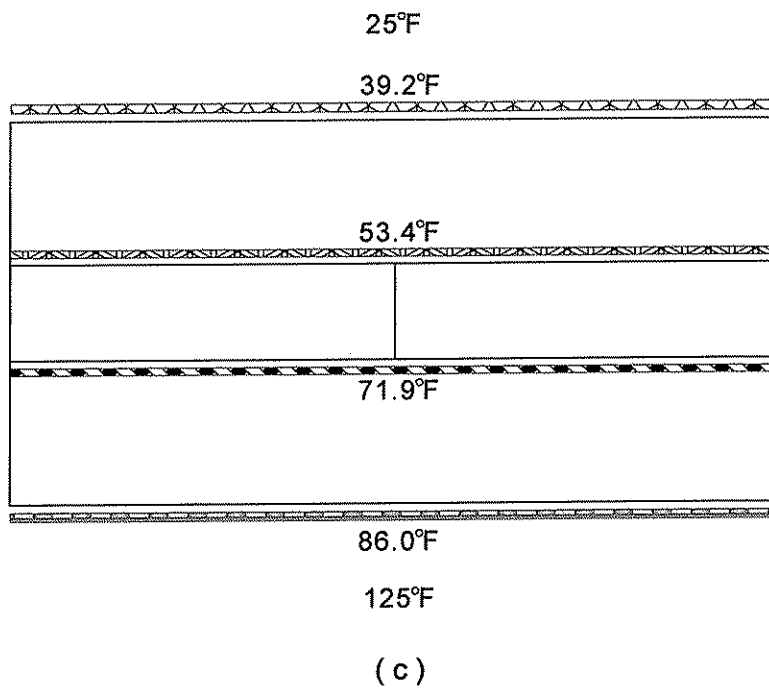
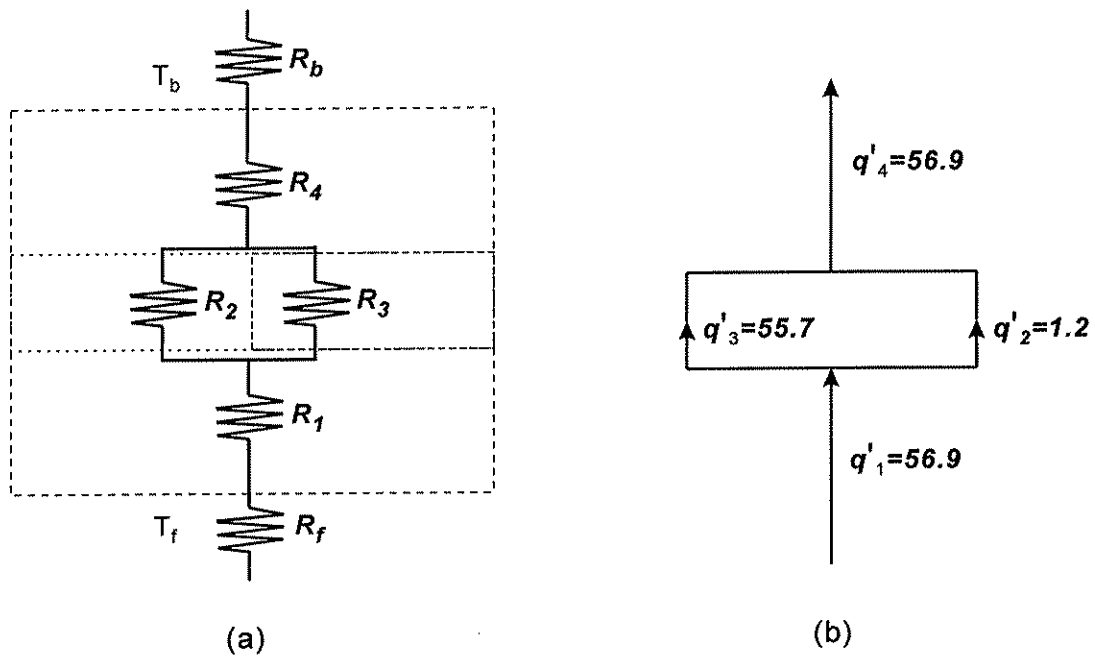

Figure 3.5 Summary of results of isothermal plane calculations: (a) thermal resistance; (b) heat flux; (c) temperature distribution.

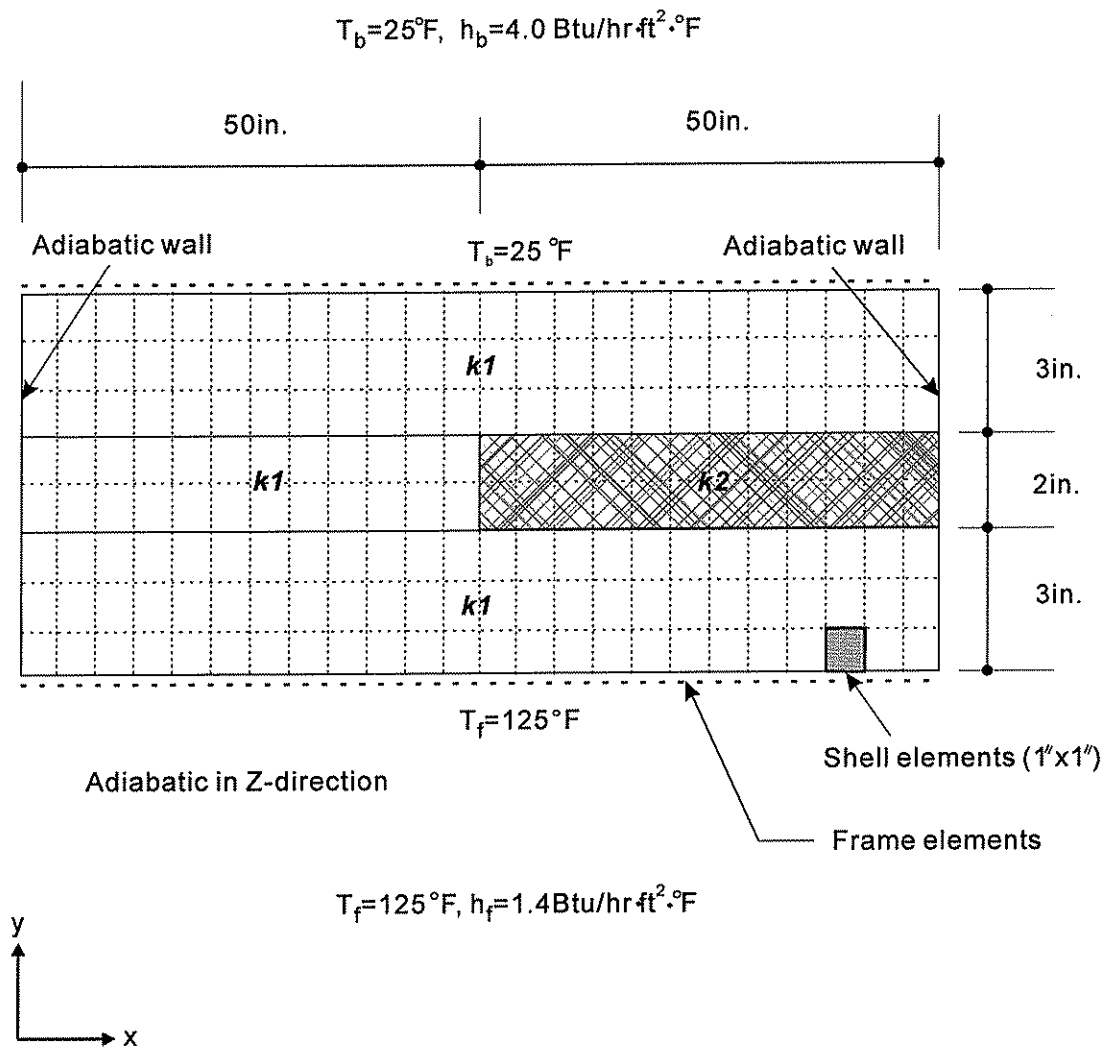

Figure 3.6 Finite element model of assemblage of materials.



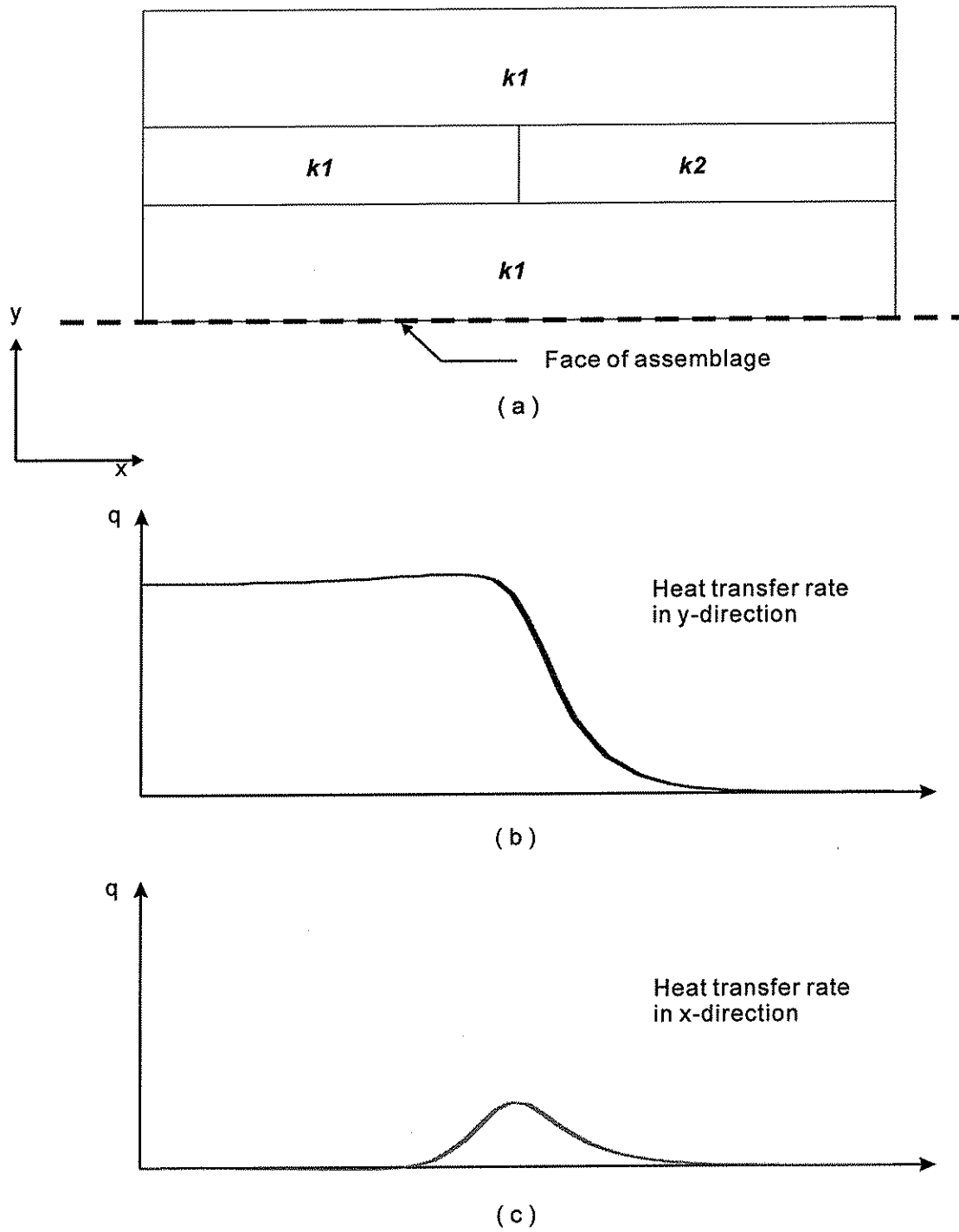
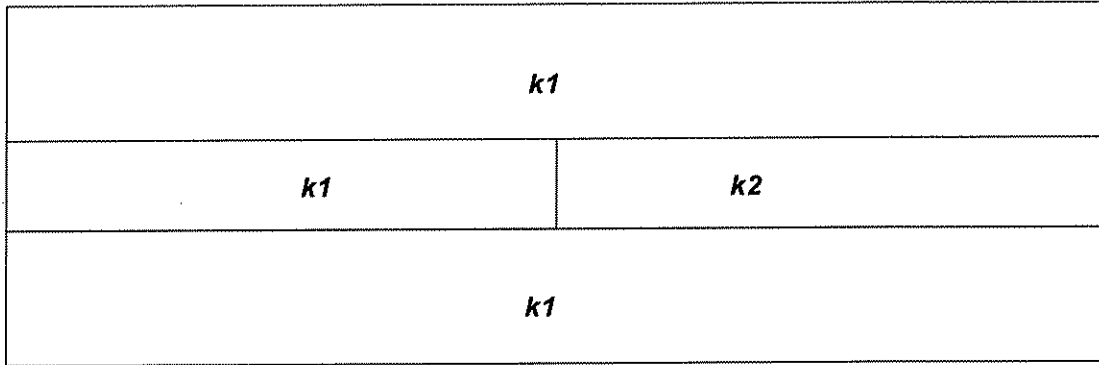
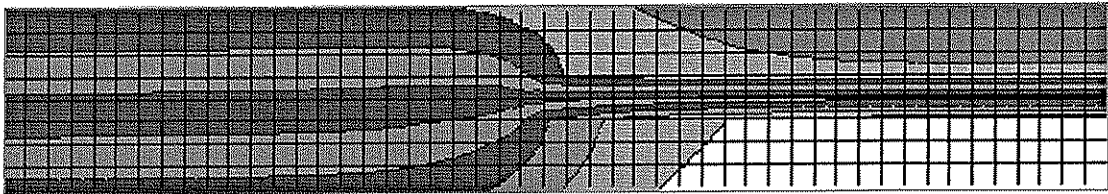

Figure 3.7 Results from the finite element method analysis: (a) assemblage of material; (b) heat transfer rate in  $y$ -direction at face; (c) heat transfer rate in  $x$ -direction at face.



(a)



(b)

Figure 3.8 Temperature contour from the finite element method analysis:  
 (a) assemblage of material; (b) temperature contour.

## CHAPTER 4 DEVELOPMENT OF THE CHARACTERISTIC SECTION METHOD

### 4.1 INTRODUCTION

Chapter 2 explained how classical calculation methods (parallel flow and isothermal plane) and the finite element method can be used to estimate R-values. The finite element method is used to model the heat transfer in assemblies of materials, and to model the guarded-hot-box test in particular. Chapter 3 compared R-value calculations made using classical calculation methods and calculations made using the finite element method. The limitations of the classical calculation methods were demonstrated.

This chapter proposes a new simplified calculation method to estimate R-values for precast concrete sandwich wall panels. The proposed method is called the *Characteristic Section Method*. The proposed method was developed by studying the heat transfer through the *characteristic section* in a sandwich panel. In this report, the term *characteristic section* refers to an assemblage of concrete and insulation in a geometrical configuration that occurs repeatedly throughout typical sandwich wall panels.

Section 4.2 explains the development of the characteristic section, and defines its boundary conditions and notation. Section 4.3 continues with this characteristic section, and examines the effect of each geometrical variable that defines the characteristic section on the heat transfer behavior of the characteristic section. Section 4.4 presents the proposed method and Section 4.5 describes how the method was developed. This section also examines the accuracy of the R-values calculate with the Characteristic Section Method as compared to the classical calculation methods and finite element method. To examine the accuracy of the proposed method, many characteristic sections are analyzed for a wide range of geometrical and material properties. Finally, in Section 4.6, the approach taken to compute the R-value for a characteristic section is extended to the full geometry of an entire sandwich wall panel. R-values computed using the proposed Characteristic Section Method are compared with R-values computed from finite element analysis results.

### 4.2 DEFINITION OF THE CHARACTERISTIC SECTION

As explained earlier, the characteristic section is the basic assemblage of concrete and insulation in a geometrical configuration that occurs repeatedly throughout typical precast concrete sandwich wall panels. Figure 4.1 shows three typical precast concrete sandwich wall panels, which have various arrangements of the solid concrete regions. The panel in Figure 4.1(a) is constructed with eight solid concrete regions of the same size in the span of the panel, as well as solid concrete regions at both ends of the panel. The panel in Figure 4.1(b) is similar to the panel in Figure 4.1(a), except that the eight solid concrete regions in the span of the panel are located on both edges of the panel instead of nearer the middle of the panel. The panel in Figure 4.1(c) is constructed with solid concrete ribs along both edges of the

panel. As mentioned previously, these different solid concrete regions are used to place inserts for lifting and handling, and also to place hardware for connections to the foundation and to adjacent panels.

All three typical precast concrete sandwich wall panels shown in Figure 4.1 exhibit quarter symmetry, so that a cut along line a-a creates a quarter size section of the panel which has the same geometry as each of the remaining quarters of the panel. Also shown in Figure 4.1 are sections a cut at A-A and B-B. As shown in Figure 4.2, sections A-A and B-B are symmetric with respect to an axis b-b. Making a cut at b-b in each case leads to the characteristic section as shown in Figure 4.3.

Figure 4.4 introduces the notation used to describe the characteristic section. The total section width is denoted as  $W$ , the width of the solid concrete region is  $w_s$ , and the total thickness of the panel is  $t$ . The thickness of the face wythe is  $t_{cf}$ , the thickness of the back wythe is  $t_{cb}$ , and the thickness of the insulation wythe is  $t_i$ . The boundary conditions on the characteristic section include adiabatic walls for both the left and right sides of the characteristic section and convections. Note that these boundary conditions are based on the guarded hot box test. The air temperatures for the back and face of the section are  $T_b$  and  $T_f$ , respectively, and the air convections for the back and face of the section are  $h_b$  and  $h_f$ , respectively. The material conductivities are denoted as  $k_{in}$  and  $k_{con}$  for the insulation and concrete, respectively.

### 4.3 HEAT TRANSFER THROUGH THE CHARACTERISTIC SECTION

This section examines the effects of individual variables that define the properties of the characteristic section on the heat transfer characteristics of the section. The insulation thickness, concrete thickness, and width of the solid concrete region are the variables. A series of finite element analyses are performed in which these variables are systematically varied. Other parameters that are held constant in all analyses include: concrete and insulation conductivities of 12.05 Btu·in/hr·ft<sup>2</sup>·°F and 0.26 Btu·in/hr·ft<sup>2</sup>·°F, respectively; natural convection of 1.46 Btu/hr·ft<sup>2</sup>·°F for the hot side with an air temperature of 125°F; forced convection of 4.0 Btu/hr·ft<sup>2</sup>·°F for the cold side with an air temperature of 25°F. The effects of variations in insulation thickness, concrete thickness, and width of the solid concrete region on the heat transfer characteristics are described in the following sub-sections.

#### 4.3.1 Insulation Thickness

Figure 4.5 shows the effect of insulation thickness on the heat flux through the characteristic section. Figure 4.5(a) shows the dimensions of the characteristic section, and Figure 4.5(b) shows the heat flux along the width of the panel with different insulation thicknesses. Both figures are drawn to the same horizontal scale, and the dashed line drawn between the figures shows the location of the end of the solid concrete region at  $x=24$  in.

As shown in Figure 4.5(a), the thickness of the insulation layer  $t_i$  is varied from 1 to 4 in. The remaining dimensions are fixed as follows:  $t_{cb}=t_{cf}= 3$  in.;  $w_s=24$  in.;

$W=100$  in. Thus, the total panel thickness  $t$  varies from 7 to 10 in. as the insulation thickness varies.

In Figure 4.5(b), the heat flux is plotted on the vertical axis, and the position along the width of the panel  $x$  is plotted on the horizontal axis. This figure shows that an increase in insulation thickness reduces the heat flux along the entire width of the panel. As expected, for any given insulation thickness, the heat flux is greater in the solid concrete region as compared to the insulation region, and the heat flux in the solid concrete region reduces as insulation thickness increases simply because the total panel thickness also increases as the insulation thickness increases.

#### 4.3.2 Concrete Thickness

Figure 4.6 shows the effect of concrete thickness on heat flux through the characteristic section. Figure 4.6(a) shows the dimensions of the characteristic section, and Figure 4.6(b) shows the heat flux along the width of the panel with different concrete thicknesses. Both figures are drawn to the same horizontal scale, and the dashed line drawn between the figures shows the location of the end of the solid concrete region at  $x=24$  in.

As shown in Figure 4.6(a), the thickness of the concrete wythe  $t_c$  varies from 1 to 5 in. The remaining dimensions are fixed as follows:  $t_i=2$  in.;  $w_s=24$  in.;  $W=100$  in. The total panel thickness  $t$  varies from 4 to 12 in. as the concrete thickness varies.

In Figure 4.6(b), the heat flux is plotted on the vertical axis, and the position along the width of the panel  $x$  is plotted on the horizontal axis. This figure shows that, as expected, for any given concrete thickness, the heat flux is greater in the solid concrete region as compared to the insulated region. This figure also shows that increasing the concrete thickness reduces the heat flux in the solid concrete region, because the total panel thickness increases. The heat flux, however, is not effected by the concrete wythe thickness in the location of the insulation. As a result, the slope of the heat flux changes significantly around the transition of the solid concrete region to the insulated region.

#### 4.3.3 Width of Solid Concrete Region

Figure 4.7 shows the effect of the width of the solid concrete on heat flux through the characteristic section. Figure 4.7(a) shows the dimensions of the characteristic section and Figure 4.7(b) shows the heat flux along the width of the panel with different widths of solid concrete regions. Both figures are drawn to the same horizontal scale, and the dashed lines drawn between the figures show the varied location of the end of the solid concrete region. The markers a through e on Figure 4.7(a) indicate the end of the solid concrete regions, and those markers are also used in the plots of heat flux in Figure 4.7(b).

As shown in Figure 4.7(a), the width of solid concrete region  $w_s$  varies from 6 to 30 in. The remaining dimensions are fixed as follows:  $t_{cb}=t_{cf}=3$  in.;  $t_i=2$  in.;  $W=100$  in. Thus, the total thickness  $t$  is also fixed as 8 in.

In Figure 4.7(b) the heat flux is plotted on the vertical axis, and the position along the width of the panel  $x$  is plotted on the horizontal axis. This figure shows that the heat flux are the same, except that the plots are shifted with the width of the solid concrete region.

#### 4.4. DESCRIPTION OF THE CHARACTERISTIC SECTION METHOD

##### 4.4.1 Overview

In the proposed Characteristic Section Method, thermal bridges in sandwich panels created by solid concrete paths are treated using what may be considered to be a zone method. To compute an R-value, the panel is divided into two zones. The first region is treated as a perfectly insulated panel without any thermal bridge. The second region is treated as a solid concrete panel without any insulation. The total thermal resistance of the panel is calculated as the resistances of these two regions added together in parallel.

The portion of the panel that is treated as a solid concrete panel without any insulation is larger than the actual solid concrete regions that exist in the panel. There is an effected zone around each solid concrete region that is added to the actual area of the solid concrete region to obtain the size of the concrete region used in the calculation. The size of the effected zone  $E_z$  is computed as:

$$E_z = 1.4 - 0.1 \cdot t_i + 0.4 \cdot t_c \quad (4.1)$$

where  $t_i$  is the thickness of the insulation layer, and  $t_c$  is the thicknesses of the concrete wythes. This is an empirical equation with all dimensions expressed in in. The equation was developed for the case where the thicknesses of the face and back wythes are the same, and the material conductivities are 12.05 Btu·in/hr·ft<sup>2</sup>·°F and 0.26 Btu·in/hr·ft<sup>2</sup>·°F for the concrete and insulation, respectively.

Equation (4.1) can be expressed more generally to account for different face and back wythe thicknesses, and for different concrete and insulation conductivities:

$$E_z = 1.4 - 0.1 \cdot t_i \cdot \alpha + \{0.4 \cdot t_{cf} + 0.1 \cdot (t_{cb} - t_{cf})\} \cdot \beta \quad (4.2)$$

In this equation,  $t_i$ ,  $t_{cf}$  and  $t_{cb}$  are the thicknesses of the insulation layer, concrete face wythe, and concrete back wythe, respectively. The values  $\alpha$  and  $\beta$  are modifiers to account for insulation and concrete conductivities ( $k_{in}$  and  $k_{con}$ ) that are different from the values assumed in Equation (4.1) and are computed as:

$$\alpha = 1 + 2.25 \cdot \frac{k_{in} - 0.26}{0.26} \quad (4.3)$$

and

$$\beta = 1 + 1.458 \cdot \frac{k_{con} - 12.05}{12.05} \quad (4.4)$$

The equations presented above were developed based on finite element heat transfer analyses of the characteristic section. Details of the development of the equations are presented in Section 4.5.

The basis for the proposed method is explained in Figures 4.8 and 4.9. Figure 4.8(a) shows a 3-2-3-24 characteristic section that is 100 in. wide. A finite element analysis was performed to determine the heat flux in each element. The heat flux on the face is plotted with a solid line in Figure 4.8(b). The heat flux varies along the width  $x$ , and its variation across the width of the characteristic section is represented in the figure as  $q'(x)$ . The integration of the heat flux along the width of the section is equal to the total heat flux.

$$q = \int q'(x) dA \quad (4.5)$$

Graphically, this is the area shown shaded in Figure 4.8(b). Figure 4.8(c) shows a simplified representation of the heat flux. The area shown shaded in Figure 4.8(c) is the same as the area shown in Figure 4.8(b).

Figure 4.9 illustrates the calculations that are performed to estimate the R-value. There are two zones: one is the solid concrete zone, and the other is the perfectly insulated zone, as explained previously. Each zone is denoted by the subscripts  $s$  and  $p$ , respectively. In other words,  $R_s$  and  $A_s$ , refer to the thermal resistance and area in the solid concrete zone, respectively.  $R_p$  and  $A_p$  refer to the same properties in the perfectly insulated zone.

Equation 4.2 is used to calculate  $E_z$ , and once  $E_z$  is known,  $A_s$  and  $A_p$  can be calculated with adding the  $E_z$  to the solid concrete region and deducting the  $E_z$  from the perfectly insulated area. In each zone, the R-value is calculated as follows. With given numerical values of the material conductivity ( $k$ ) and the thickness ( $t$ ) of each layer, the thermal transmittances,  $U$ , are calculated by using Equation 4.5. In the following procedure, the R-value in each material can be calculated from the inverse relationship between the thermal transmittance and the thermal resistance as shown in Equation (4.6).

$$U = \frac{k}{t} \quad (4.5)$$

$$R = \frac{1}{U} \quad (4.6)$$

The summation of the thermal resistances in each layer gives the thermal resistance in each zone. Then, compute the R-value treating the solid concrete area and insulated areas in parallel by using Equation 4.7.

$$\frac{1}{R} = \frac{A'_s}{R_s} + \frac{A'_p}{R_p} \quad (4.7)$$

The  $A'_s$  and  $A'_p$  represent the area rate of solid concrete zone and perfect panel zone to total panel area, respectively. These portions are calculated by the area of the each zone divided by the total panel area ( $A'_s = A_s/A_t$ ,  $A'_p = A_p/A_t$ ).

The key to the proposed method is the accurate determination of the width of the effected zone  $E_z$ . Equation 4.2 shows that the width of effected zone depends on the thicknesses and conductivities of materials used to construct the panel. The development of the equations used to estimate the width of the effected zone are explained in Section 4.5.

#### 4.4.2 Example R-value Calculations

This section presents three examples to illustrate how the proposed method is used to calculate the R-values of precast concrete sandwich wall panels. Values for thermal resistances and conductance are taken from Chapter 9 of the PCI Handbook.

##### Example 1

###### Problem:

Determine the R-value for the sandwich panel shown below for conductivities of 12.05 Btu-in/hr-ft<sup>2</sup>·°F and 0.26 Btu-in/hr-ft<sup>2</sup>·°F for the concrete and insulation, respectively.

###### Solution:

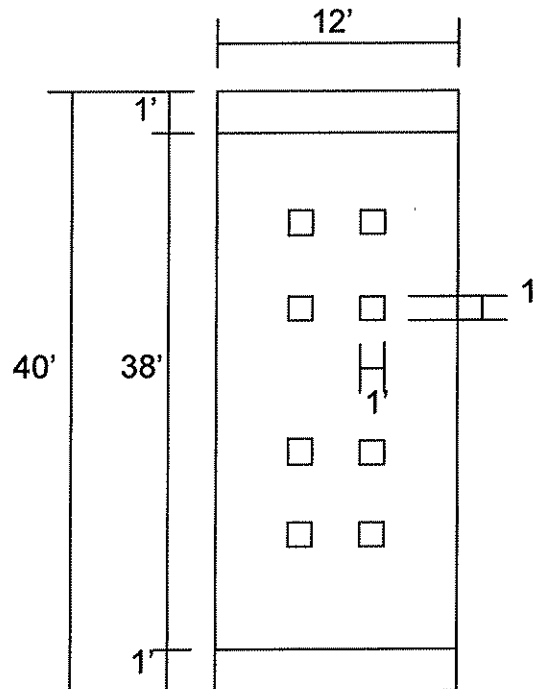



From the panel thicknesses, the effected zone dimension  $E_z$  is computed as:

$$E_z = 1.4 - 0.1 \cdot t_i + 0.4 \cdot t_c$$

$$E_z = 1.4 - 0.1 \cdot (2) + 0.4 \cdot 3$$

$$E_z = 2.4''$$

Add  $E_z$  to the actual solid concrete areas to obtain the areas of the panel to treat as solid concrete (with dashed line) and as insulated.

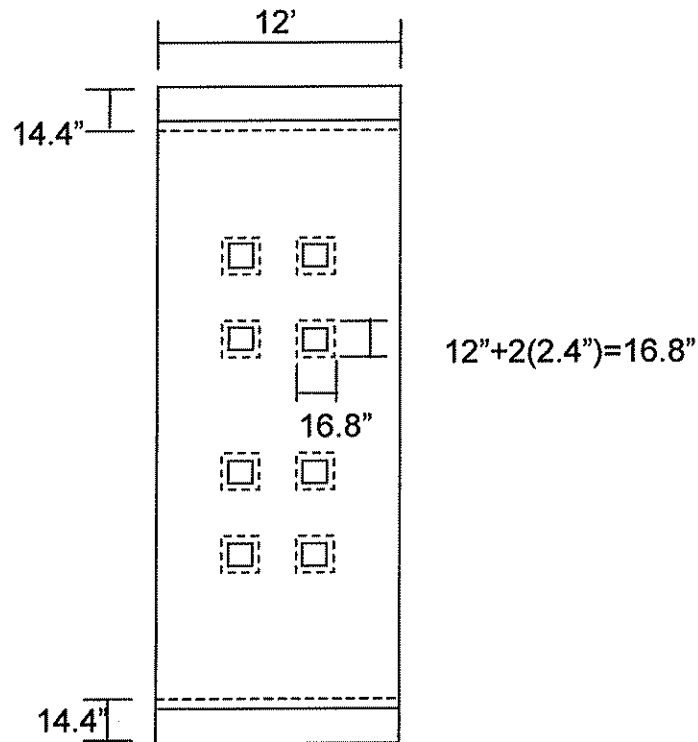

Calculate the area of the panel ( $A_t$ ), solid concrete area ( $A_s$ ), and insulated panel area ( $A_p$ ):

$$A_t = \text{panel area} = (40')(12') = 480 \text{ ft}^2 = 69120 \text{ in}^2$$

$$A_s = \text{concrete area} = 2(14.4)(144) + 8(16.8)(16.8) = 6405 \text{ in}^2$$

$$A_p = \text{insulated area} = 69120 - 6405 = 62715 \text{ in}^2$$

The resistance of that portion of the panel that is treated as the insulated panel is calculated from the resistances of the concrete, insulation, and surfaces in series.

Insulated path

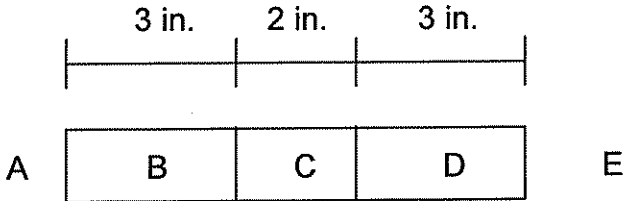

		k	t	U=k/t	R=1/U Winter	R=1/U Summer
A	Outside surface	-	-	-	0.17	0.25
B	Concrete	12.05	3	4.02	0.25	0.25
C	Insulation	0.26	2	0.13	7.69	7.69
D	Concrete	12.05	3	4.02	0.25	0.25
E	Inside surface	-	-	-	0.68	0.68
					9.04	9.12

The resistance of that portion of the panel that is treated as the solid concrete panel is calculated from the resistances of the concrete and surfaces in series.

Concrete path

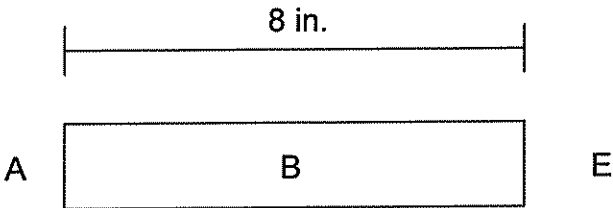

		k	t	U=k/t	R=1/U Winter	R=1/U Summer
A	Outside surface	-	-	-	0.17	0.25
B	Concrete	12.05	8	1.51	0.66	0.66
C	Insulation	-	-	-	0.68	0.68
					1.51	1.59

Calculate the fractional areas of the panel that are treated as solid concrete and as insulated:

$$A_s / A_t = 6405 / 69120 = 0.093$$

$$A_p / A_t = 62715 / 69120 = 0.907$$

Compute the R-value treating the solid concrete areas and insulated areas in parallel.

Winter:

$$\frac{1}{R} = \frac{0.907}{9.04} + \frac{0.093}{1.51}$$

$$R = 6.18 \text{ hr} \cdot \text{ft}^2 \cdot \text{°F}/\text{Btu}$$

Summer:

$$\frac{1}{R} = \frac{0.907}{9.12} + \frac{0.093}{1.59}$$

$$R = 6.33 \text{ hr} \cdot \text{ft}^2 \cdot \text{°F}/\text{Btu}$$

### Example 2

*Problem:*

Repeat Example 1 using the thickness of assemblage of 6-1-1 in., face concrete wall, insulation wall, and backside concrete wall, respectively.

*Solution:*

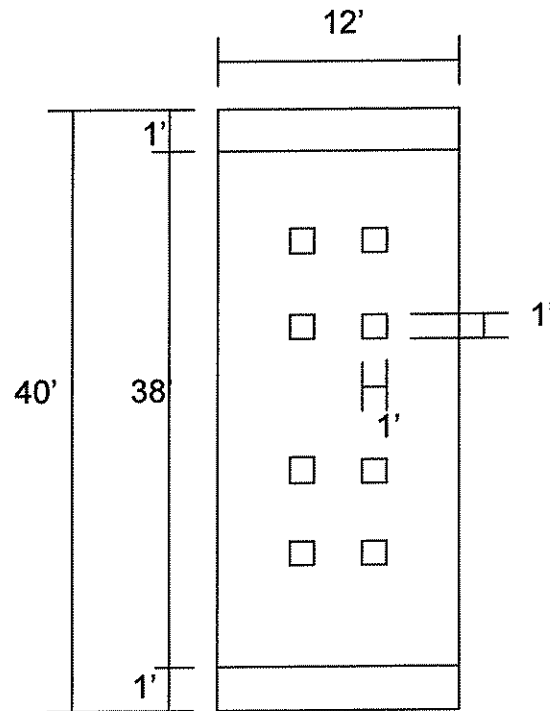

From the panel thicknesses, the effected zone dimension  $E_z$  is computed as:

$$E_z = 1.4 - 0.1 \cdot t_i + 0.4 \cdot t_{cf} + 0.1 \cdot (t_{cb} - t_{cf})$$

$$E_z = 1.4 - 0.1 \cdot (1) + 0.4 \cdot (6) + 0.1 \cdot \{(1) - (6)\}$$

$$E_z = 3.2''$$

Add  $E_z$  to the actual solid concrete areas to obtain the areas of the panel to treat as solid concrete (with dashed line) and as insulated.

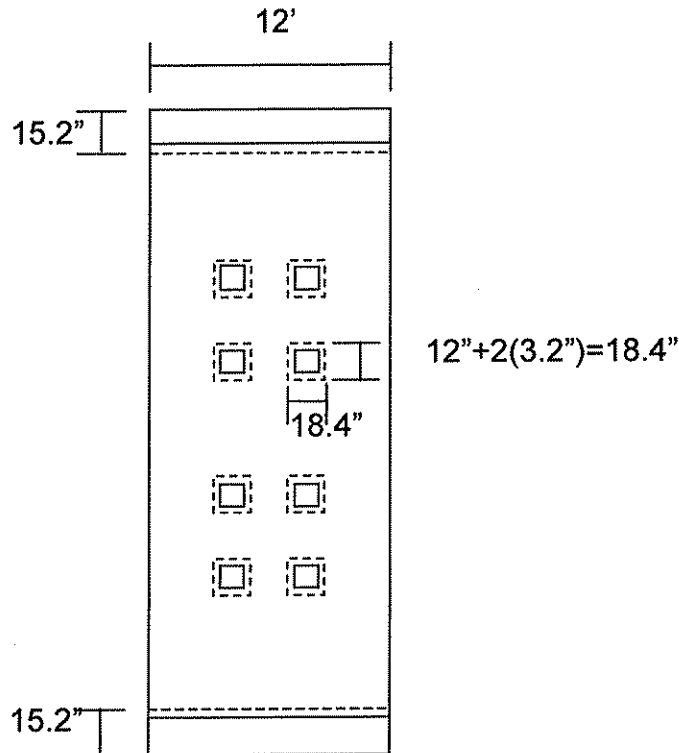

Calculate the area of the panel ( $A_t$ ), solid concrete area ( $A_s$ ), and insulated panel area ( $A_p$ ):

$$A_t = \text{panel area} = (40')(12') = 480 \text{ ft}^2 = 69120 \text{ in}^2$$

$$A_s = \text{concrete area} = 2(15.2)(144) + 8(18.4)(18.4) = 7086 \text{ in}^2$$

$$A_p = \text{insulated area} = 69120 - 7086 = 62034 \text{ in}^2$$

The resistance of that portion of the panel that is treated as the insulated panel is calculated from the resistances of the concrete, insulation, and surfaces in series.

Insulated path

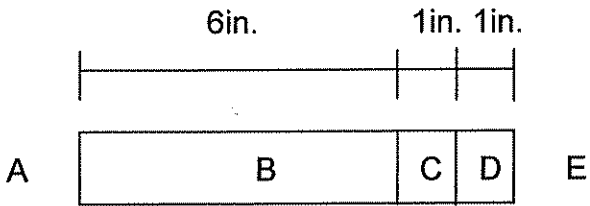

		k	t	U=k/t	R=1/U Winter	R=1/U Summer
A	Outside surface	-	-	-	0.17	0.25
B	Concrete	12.05	6	2.01	0.50	0.50
C	Insulation	0.26	1	0.26	3.85	3.85
D	Concrete	12.05	1	12.05	0.08	0.08
E	Inside surface	-	-		0.68	0.68
					5.28	5.36

The resistance of that portion of the panel that is treated as the solid concrete panel is calculated from the resistances of the concrete and surfaces in series.

Concrete path

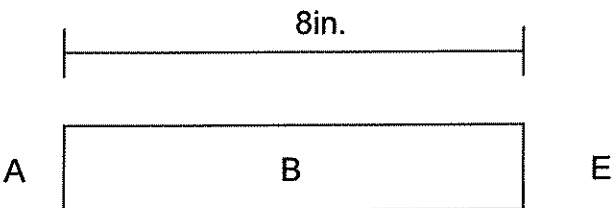

		k	t	U=k/t	R=1/U Winter	R=1/U Summer
A	Outside surface	-	-	-	0.17	0.25
B	Concrete	12.05	8	1.51	0.66	0.66
C	Insulation	-	-	-	0.68	0.68
					1.51	1.59

Calculate the fractional areas of the panel that are treated as solid concrete and as insulated:

$$A_s / A_t = 7086 / 69120 = 0.103$$

$$A_p / A_t = 62034 / 69120 = 0.897$$

Compute the R-value treating the solid concrete areas and insulated areas in parallel.

Winter:

$$\frac{1}{R} = \frac{0.897}{5.28} + \frac{0.103}{1.51}$$

$$R = 4.20 \text{ hr} \cdot \text{ft}^2 \cdot \text{°F}/\text{Btu}$$

Summer:

$$\frac{1}{R} = \frac{0.897}{5.36} + \frac{0.103}{1.59}$$

$$R = 4.31 \text{ hr} \cdot \text{ft}^2 \cdot \text{°F}/\text{Btu}$$

### Example 3

*Problem:*

Repeat Example 4.1 using conductivities of 10.00 Btu·in/hr·ft<sup>2</sup>·°F and 0.15 Btu·in/hr·ft<sup>2</sup>·°F for the concrete and insulation, respectively.

*Solution:*

Calculate the modifiers  $\alpha$  and  $\beta$  to account for insulation and concrete conductivities that are different from the values assumed in Equation (4.1)

$$\alpha = 1 + 2.25 \cdot \frac{k_{in} - 0.26}{0.26} = 1 + 2.25 \cdot \frac{0.15 - 0.26}{0.26} = 0.05$$

$$\beta = 1 + 1.458 \cdot \frac{k_{con} - 12.05}{12.05} = 1 + 1.458 \cdot \frac{10.00 - 12.05}{12.05} = 0.75$$

From the panel thicknesses, the effected zone dimension  $E_z$  is computed as:

$$E_z = 1.4 - 0.1 \cdot t_i \cdot \alpha + \{0.4 \cdot t_c + 0.1 \cdot (t_{cb} - t_{cf})\} \cdot \beta$$

$$E_z = 1.4 - 0.1 \cdot (2) \cdot (0.05) + 0.4 \cdot (3) \cdot (0.75)$$

$$E_z = 2.3''$$

Add  $E_z$  to the actual solid concrete areas to obtain the areas of the panel to treat as solid concrete (with dashed line) and as insulated.

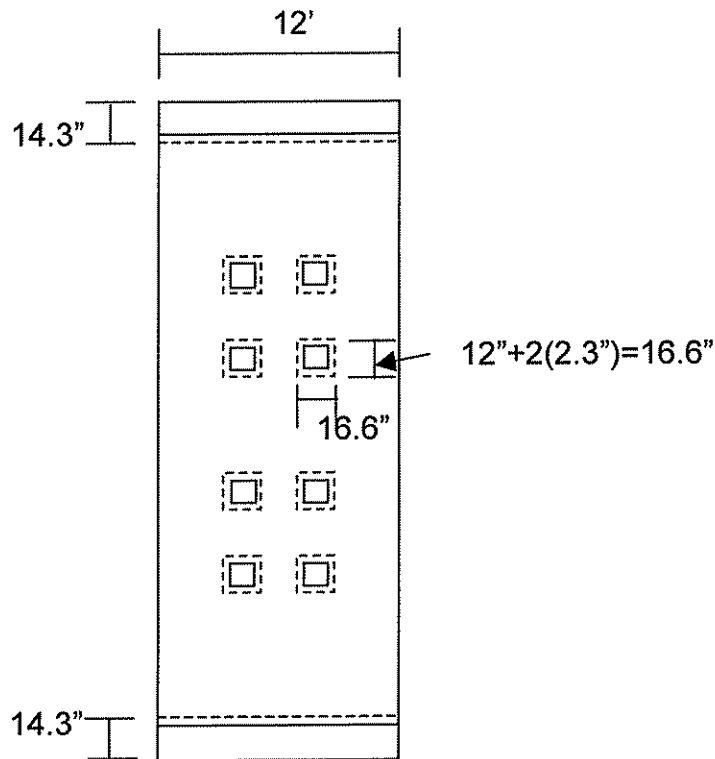

Calculate the area of the panel ( $A_t$ ), solid concrete area ( $A_s$ ), and insulated panel area ( $A_p$ ):

$$A_t = \text{panel area} = (40')(12') = 480\text{ft}^2 = 69120 \text{ in}^2$$

$$A_s = \text{concrete area} = 2(14.3)(144) + 8(16.6)(16.6) = 6323 \text{ in}^2$$

$$A_p = \text{insulated area} = 69120 - 6323 = 62797 \text{ in}^2$$

The resistance of that portion of the panel that is treated as the insulated panel is calculated from the resistances of the concrete, insulation, and surfaces in series.

Insulated path

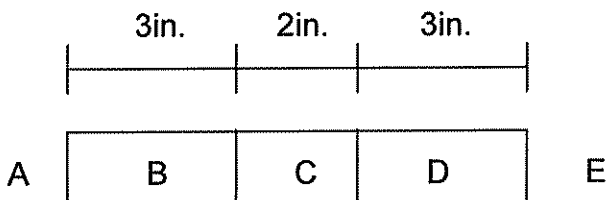

		k	t	U=k/t	R=1/U Winter	R=1/U Summer
A	Outside surface	-	-	-	0.17	0.25
B	Concrete	10.00	3	3.33	0.30	0.30
C	Insulation	0.15	2	0.08	12.50	12.50
D	Concrete	10.00	3	3.33	0.30	0.30
E	Inside surface	-	-		0.68	0.68
					13.95	14.03

The resistance of that portion of the panel that is treated as the solid concrete panel is calculated from the resistances of the concrete and surfaces in series.

Concrete path

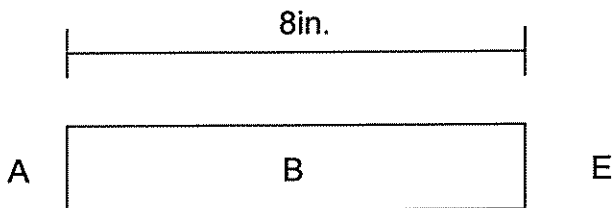

		k	t	U=k/t	R=1/U Winter	R=1/U Summer
A	Outside surface	-	-	-	0.17	0.25
B	Concrete	10.00	8	1.25	0.80	0.80
C	Insulation	-	-	-	0.68	0.68
					1.65	1.73

Calculate the fractional areas of the panel that are treated as solid concrete and as insulated:

$$A_s/A_t = 6323/69120 = 0.091$$

$$A_p/A_t = 62797/69120 = 0.909$$

Compute the R-value treating the solid concrete areas and insulated areas in parallel.

Winter:

$$\frac{1}{R} = \frac{0.909}{13.95} + \frac{0.091}{1.65}$$

$$R = 8.31 \text{ hr} \cdot \text{ft}^2 \cdot \text{F/Btu}$$



Summer:

$$\frac{1}{R} = \frac{0.909}{14.03} + \frac{0.091}{1.73}$$
$$R = 8.52 \text{ hr} \cdot \text{ft}^2 \cdot ^\circ\text{F} / \text{Btu}$$

#### 4.5 DEVELOPMENT OF EQUATIONS FOR WIDTH OF EFFECTED ZONE

Section 4.4 provided an overview of the proposed Characteristic Section Method for calculating R-values. A key element in the proposed method is the calculation of the width of the effected zone,  $E_z$ , using Equations (4.1) through (4.4). This section explains how these equations were developed.

The general procedure was as follows. First, a finite element model was created of a characteristic section for a fixed set of parameters (wythe thicknesses, material conductivities, etc.). One of these parameters was then systematically varied. Finite element analyses were performed to determine the R-value of each characteristic section. The Characteristic Section Method was then used to compute the R-value of each section for incrementing values of  $E_z$ , beginning with  $E_z = 0$ , until the same R-value obtained by the finite element analyses was obtained. This value of  $E_z$  was then plotted versus the parameter that was varied to show the relationship between  $E_z$  and the parameter. Once this relationship was shown, an equation was sought to represent this relationship. The resulting equations are the equations to compute the width of the effected zone, i.e. Equations (4.1) to (4.4).

Symmetric characteristic sections (i.e. sections in which the face and back wythe have the same thickness) were studied first, then unsymmetric sections (i.e. sections in which the face and back wythes have different thickness) were studied. Finally, symmetric characteristic sections in which the concrete and insulation thermal conductivities are varied were studied.

##### 4.5.1 Symmetric Cases

The results of analyses to determine an equation for  $E_z$  as a function of concrete wythe thickness and insulation layer thickness for symmetric characteristic sections are summarized in Figure 4.10 and Table 4.1. Figure 4.10 shows the variation in  $E_z$  with insulation thickness for a range of symmetric characteristic section thicknesses. Table 4.1 summarizes the  $E_z$  values that are plotted as discrete points in Figure 4.10. These points are connected with dashed lines in the figure.

Model parameters in these analyses include concrete and insulation conductivities are 12.05 Btu-in/hr-ft<sup>2</sup>·°F and 0.26 Btu-in/hr-ft<sup>2</sup>·°F, respectively. Convections are natural convection (1.46 Btu/ hr-ft<sup>2</sup>·°F) for the hot side air temperature 125°F on the face wythe, and forced convection (4.0 Btu/ hr-ft<sup>2</sup>·°F) for the cold side air temperature 25°F on the back wythe. The thickness of the concrete wythe  $t_{cb} = t_{cf}$  is varied from 1 to 5 in., and the thickness of the insulation layer  $t_i$  is varied from 1 to 4 in. The remaining dimensions are fixed as follows:  $w_s = 24$  in.;

$W=100$  in. Thus, the total characteristic section thickness varies from 3 to 14 in. as the concrete and insulation thicknesses vary.

Also shown in Figure 4.10 is Equation (4.1) plotted as solid lines for the various wythe thickness combinations. As shown in the figure, good agreement is obtained between the discrete points (the  $E_z$  values obtained by fitting the Characteristic Section Model to the R-value obtained from the finite element results as described earlier) and the continuous lines generated by the equation. Thus, it is concluded that Equation (4.1) accurately captures the influence of concrete wythe thickness and insulation layer thickness on the width of the effected zone for symmetric characteristic sections.

#### 4.5.2 Unsymmetric Cases

The results of analyses to determine an equation for  $E_z$  as a function of concrete wythe thickness for unsymmetric characteristic sections are summarized in Figure 4.11 and Table 4.2. Figure 4.11 shows the variation in  $E_z$  with concrete wythe thickness for two different unsymmetric characteristic section thicknesses. Table 4.2 summarizes the  $E_z$  values that are plotted in Figure 4.11 as discrete points. These points are connected with dashed lines in the figure.

Model parameters in these analyses include concrete and insulation conductivities of  $12.05 \text{ Btu}\cdot\text{in}/\text{hr}\cdot\text{ft}^2\cdot^\circ\text{F}$  and  $0.26 \text{ Btu}\cdot\text{in}/\text{hr}\cdot\text{ft}^2\cdot^\circ\text{F}$ , respectively. Convections are natural convection ( $1.46 \text{ Btu}/\text{hr}\cdot\text{ft}^2\cdot^\circ\text{F}$ ) for the hot side air temperature  $125^\circ\text{F}$  on the face wythe, and forced convection ( $4.0 \text{ Btu}/\text{hr}\cdot\text{ft}^2\cdot^\circ\text{F}$ ) for the cold side air temperature  $25^\circ\text{F}$  on the back wythe. With these constant conditions, the thicknesses of the two concrete wythes vary individually in 1-inch increments. Only one of the concrete wythe thicknesses either  $t_{cb}$  or  $t_{cf}$  varies from 1 to 6 in. when the other wythe is fixed at 6 in. thick. The remaining dimensions are also fixed as follows:  $t_i=4$  in.;  $w_s=24$  in.;  $W=100$  in. Thus, the total characteristic section thickness varies from 11 to 16 in. as one side of the concrete thickness varies.

Also shown in Figure 4.11 is Equation 4.2 plotted as solid lines for the two unsymmetric panels considered. As shown in the figure, good agreement is obtained between the discrete points (the  $E_z$  values obtained by fitting the Characteristic Section Model to the R-value obtained from the finite element results as described earlier) and the continuous lines generated by the equation. Thus it is concluded that Equation (4.2) accurately captures the influence of insulation layer thickness on the width of the effected zone for unsymmetric characteristic sections.

#### 4.5.3 Material Conductivities

The results of analyses to determine an equation for  $E_z$  as a function of concrete and insulation thermal conductivities are summarized in Figure 4.12 and Table 4.3. Figure 4.12 shows the variation in  $E_z$  with concrete and insulation thermal conductivity for one particular characteristic section geometry (3-2-3-24). Table 4.3

summarizes the  $E_z$  values that are plotted in Figure 4.12 as discrete points. These points are connected with dashed lines in the figure.

Model parameters in these analyses include natural convection (1.46 Btu/hr·ft<sup>2</sup>·°F) for the hot side air temperature 125°F on the face wythe, and forced convection (4.0 Btu/hr·ft<sup>2</sup>·°F) for the cold side air temperature 25°F on the back wythe. Geometry parameters are fixed as follows:  $t_{cb}=t_{cf}=3$  in.;  $t_i=2$  in.;  $w_s=24$  in.;  $W=100$  in. With these constant conditions, the thermal conductivities of the concrete and insulation wythes are varied. The conductivities vary from 20% to 200% of previously fixed conductivities, 12.05 Btu·in/hr·ft<sup>2</sup>·°F for the concrete, and 0.26 Btu·in/hr·ft<sup>2</sup>·°F for the insulation.

Also shown in Figure 4.12 is Equation 4.2 plotted as solid lines for the two unsymmetric panels considered. In plotting Equation 4.2, the values  $\alpha$  and  $\beta$ , modifiers to account for insulation and concrete conductivities, are computed from Equations (4.3) and (4.4). As shown in the figure, good agreement is obtained between the discrete points (the  $E_z$  values obtained by fitting the Characteristic Section Model to the R-value obtained from the finite element results as described earlier) and the continuous lines generated by the equation. Thus it is concluded that Equation (4.2) along with the  $\alpha$  and  $\beta$ , modifiers computed from Equations (4.3) and (4.4), accurately captures the influence of concrete and insulation thermal conductivities on the width of the effected zone.

#### **4.6 APPLICATION OF THE CHARACTERISTIC SECTION METHOD TO FULL PANELS**

As explained in Section 4.5, the equations for  $E_z$  were developed for the characteristic section. Two-dimensional heat transfer analyses were performed to develop these equations. In an actual sandwich panel, heat may flow in three directions. In this section, the Characteristic Section Method is used to calculate R-values for several precast concrete sandwich wall panels. In other words, it is assumed that the equations for the width of the effected zone  $E_z$ , developed for the two-dimensional case of the characteristic section, can also be applied to the three-dimensional problem of actual panels. The results presented in this section indicate that this assumption is valid. The R-values obtained from the Characteristic Section Method are compared with R-values obtained from three-dimensional finite element heat transfer analyses, and good agreement obtained.

##### **4.6.1 Symmetric Panels**

Figure 4.13 shows a typical precast sandwich wall panel which is symmetric through its thickness. The panel is constructed with a 3 inch thick face wythe, 2 inch thick insulation layer, and 3 inch thick back wythe. The panel also has eight solid concrete regions that measure 1 ft.x1ft. in plan and two solid concrete regions along the edges of the panel with widths of 2.5 ft. Material conductivities are 12.05 Btu·in/hr·ft<sup>2</sup>·°F for the concrete, and 0.26 Btu·in/hr·ft<sup>2</sup>·°F for the insulation. R-values are computed for this panel using the Characteristic Section Method and the finite element method.

From Equation (4.1), the width of the effected zone is calculated as 2.4 in. Accordingly, as shown shaded in Figure 4.14, the solid concrete zones are increased by the  $E_z$  dimension. The remainder of the panel is treated as a perfectly insulated panel. Treating the concrete and insulated regions shown in Figure 4.14 in parallel, the R-value for this example is estimated to be 5.10 hr·ft<sup>2</sup>·°F/Btu. From a finite element analysis of the full panel, the R-value is estimated to be 5.04 hr·ft<sup>2</sup>·°F/Btu. From these calculations it is concluded that the Characteristic Section Method provides a good estimate of the R-value for the symmetric panel.

#### 4.6.2 Unsymmetric Panels

Figure 4.15 shows two precast concrete sandwich wall panels that are unsymmetric through their thicknesses. Figure 4.15(a) is a 6-1-1 panel, and Figure 4.15(b) is a 1-1-6 panel. Material conductivities are 12.05 Btu·in/hr·ft<sup>2</sup>·°F for the concrete, and 0.26 Btu·in/hr·ft<sup>2</sup>·°F for the insulation. R-values are computed for these panels using the Characteristic Section Method and the finite element method.

The widths of the effected zone are calculated using Equation (4.2) for both panels ( $E_z = 2.2$  in. for the 1-1-6 panel, and  $E_z = 3.2$  in for the 6-1-1 panel), and the solid concrete zones are increased by the  $E_z$  dimension as shown in Figure 4.16. The remainder of the panel is treated as a perfectly insulated panel. Treating the concrete and insulated regions in parallel, the R-value is computed as 3.75 hr·ft<sup>2</sup>·°F/Btu for the 6-1-1 panel, and as 3.81 hr·ft<sup>2</sup>·°F/Btu for the 1-1-6 panel. Finite element analyses give R-values of 3.78 hr·ft<sup>2</sup>·°F/Btu and 3.86 hr·ft<sup>2</sup>·°F/Btu for these same two panels. From these calculations it is concluded that the Characteristic Section Method provides a good estimate of the R-value for the unsymmetric panels.

#### 4.6.3 Panels with Different Material Conductivities

The precast concrete sandwich wall panel configurations shown in Figures 4.13 and 4.15 were reanalyzed for a range of concrete and insulation thermal conductivity values. R-values were computed using the Characteristic Section Method and the finite element method. The results are shown in Tables 4.4 and 4.5. In these tables, the R-values computed using the Characteristic Section Method are given under columns labeled CSM. The material conductivity values are varied from 20 % to 180 % of the reference values of 12.05 Btu·in/hr·ft<sup>2</sup>·°F for the concrete, and 0.26 Btu·in/hr·ft<sup>2</sup>·°F for the insulation.

From the results presented in Tables 4.4 and 4.5, it is concluded that the Characteristic Section Method provides a good estimate of R-values for both symmetric and unsymmetrical panels with varying material thermal conductivity values.

Effected zone, $E_z$ (in.)				
$t_{cf} / t_{cb}$ \ $t_i$	1.0	2.0	3.0	4.0
1 / 1	1.57	1.51	1.41	1.32
2 / 2	2.11	2.05	1.94	1.83
3 / 3	2.51	2.49	2.38	2.26
4 / 4	2.86	2.88	2.78	2.65
5 / 5	3.17	3.25	3.15	3.03

Table 4.1 Variation in  $E_z$  with concrete wythe thickness and insulation layer thickness for symmetric characteristic sections.

$t_{cb} - t_i - t_{cf}$	Effected zone, $E_z$	$t_{cb} - t_i - t_{cf}$	Effected zone, $E_z$
1 - 4 - 6	2.05	6 - 4 - 1	3.05
2 - 4 - 6	2.37	6 - 4 - 2	3.05
3 - 4 - 6	2.64	6 - 4 - 3	3.11
4 - 4 - 6	2.89	6 - 4 - 4	3.18
5 - 4 - 6	3.14	6 - 4 - 5	3.27
6 - 4 - 6	3.38	6 - 4 - 6	3.38

Table 4.2 Variation in  $E_z$  with concrete wythe thickness for unsymmetrical characteristic sections.

% of variable conductivities	Effectuated zone width, $E_z$ (in.)	
	$k_{con}$ =variable, $k_{in}$ =0.26 (100% of $k_{con}$ =12.05)	$k_{con}$ =12.05, $k_{in}$ =variable (100% of $k_{in}$ =0.26)
20	0.92	2.76
40	1.38	2.69
60	2.78	2.62
80	2.15	2.56
100	2.49	2.49
120	2.82	2.43
140	3.12	2.38
160	3.42	2.32
180	3.69	2.27
200	3.96	2.22

Table 4.3 Variation in  $E_z$  with concrete and insulation thermal conductivities for a 3-2-3-24 characteristic section.

% of k	R-value					
	k <sub>con</sub> = variable k <sub>in</sub> = 0.26		k <sub>con</sub> = 12.05 k <sub>in</sub> = variable		k <sub>con</sub> = variable k <sub>in</sub> = variable	
	F.E.M.	C.S.M.	F.E.M.	C.S.M.	F.E.M.	C.S.M.
20%	7.93	7.92 (E <sub>z</sub> =1.0)	5.38	5.38 (E <sub>z</sub> =2.756)	12.97	12.92 (E <sub>z</sub> =1.356)
60%	4.88	4.89 (E <sub>z</sub> =1.7)	4.59	4.59 (E <sub>z</sub> =2.578)	5.63	5.63 (E <sub>z</sub> =1.878)
100%	4.06	4.07 (E <sub>z</sub> =2.4)	4.06	4.07 (E <sub>z</sub> =2.4)	4.06	4.07 (E <sub>z</sub> =2.4)
140%	3.66	3.66 (E <sub>z</sub> =3.1)	3.69	3.70 (E <sub>z</sub> =2.222)	3.34	3.35 (E <sub>z</sub> =2.922)
180%	3.41	3.40 (E <sub>z</sub> =3.8)	3.41	3.42 (E <sub>z</sub> =2.044)	2.92	2.92 (E <sub>z</sub> =3.444)

C.S.M. = Characteristic Section Method.

Table 4.4 R-values computed using the finite element method and the Characteristic Section Method for the panel shown in Figure 4.13.

Panel	% of k	R-value					
		$k_{con} = \text{variable}$ $k_{in} = 0.26$		$k_{con} = 12.05$ $k_{in} = \text{variable}$		$k_{con} = \text{variable}$ $k_{in} = \text{variable}$	
		F.E.M.	C.S.M.	F.E.M.	C.S.M.	F.E.M.	C.S.M.
1-1-6	20%	6.39	6.39 ( $E_z=1.15$ )	4.94	4.99 ( $E_z=2.378$ )	10.80	10.88 ( $E_z=1.328$ )
	100%	3.31	3.32 ( $E_z=202$ )	3.31	3.32 ( $E_z=2.2$ )	3.31	3.32 ( $E_z=2.2$ )
	180%	2.85	2.85 ( $E_z=3.25$ )	2.74	2.74 ( $E_z=2.002$ )	2.38	2.37 ( $E_z=3.072$ )
6-1-1	20%	6.38	6.40 ( $E_z=0.984$ )	4.78	4.85 ( $E_z=3.378$ )	10.73	10.91 ( $E_z=1.162$ )
	100%	3.27	3.27 ( $E_z=3.2$ )	3.27	3.27 ( $E_z=3.2$ )	3.27	3.27 ( $E_z=3.2$ )
	180%	2.79	2.75 ( $E_z=5.416$ )	2.72	2.71 ( $E_z=3.022$ )	2.34	2.31 ( $E_z=5.238$ )

C.S.M.= Characteristic Section Method.

Table 4.5 R-values computed using the finite element method and the Characteristic Section Method for the panels shown in Figure 4.15.



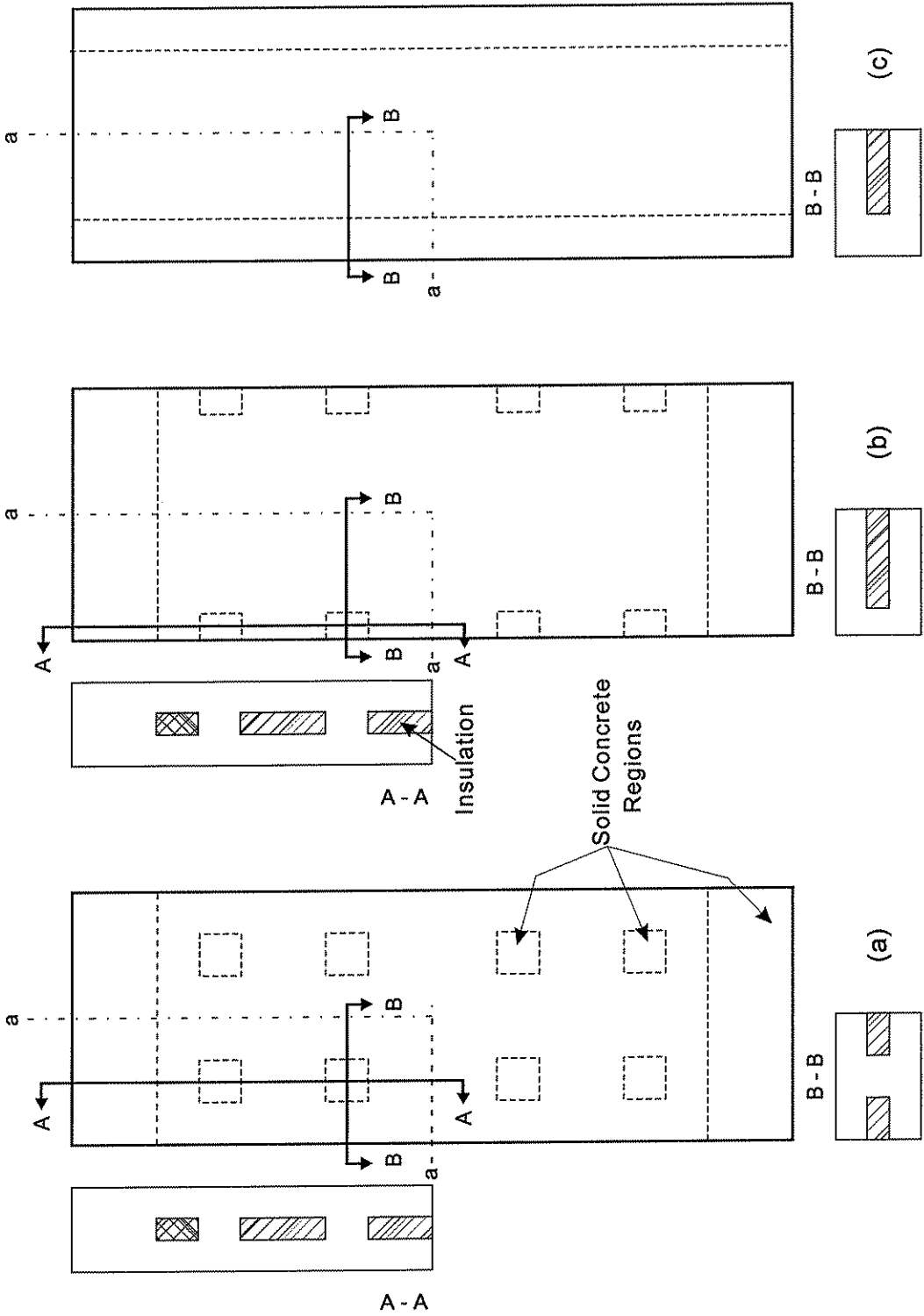

Figure 4.1 Three typical precast concrete sandwich wall panels with sections a-a that show quarter symmetry of each panel.

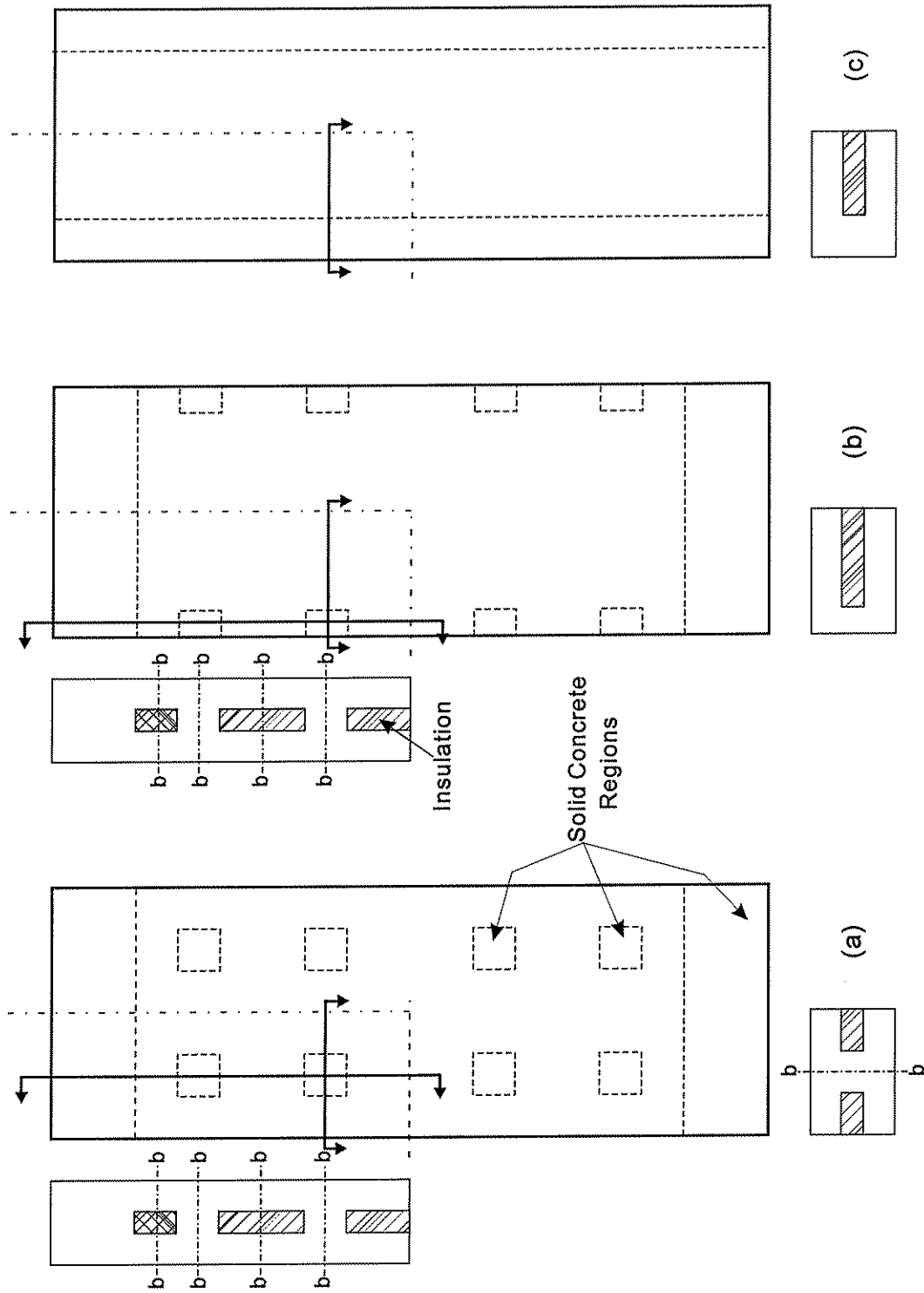

Figure 4.2 Defining a characteristic section from three typical precast concrete sandwich wall panels.

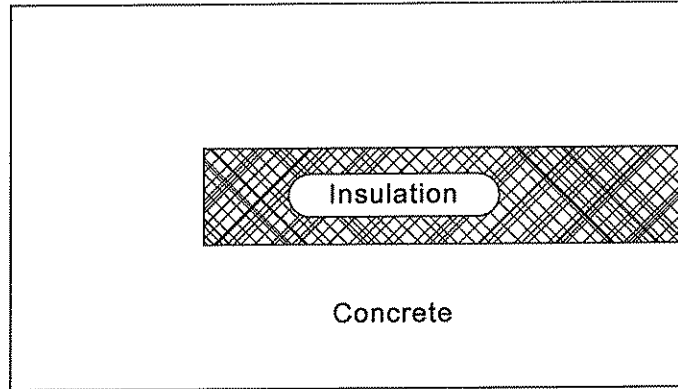

Figure 4.3 Characteristic section.

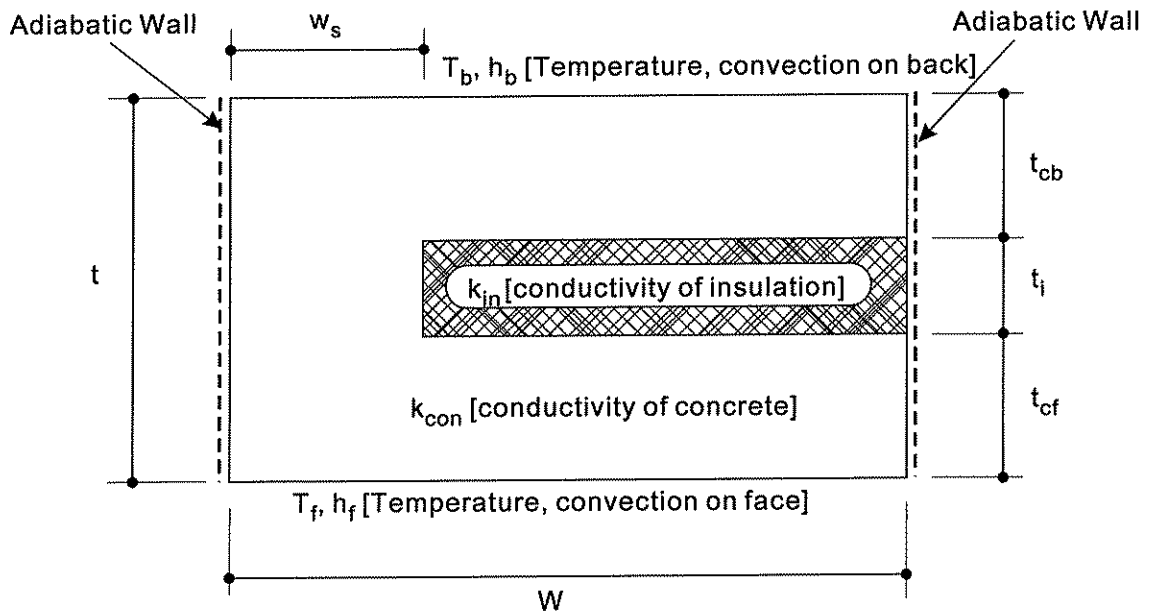

Figure 4.4 Description of notation for the characteristic section.

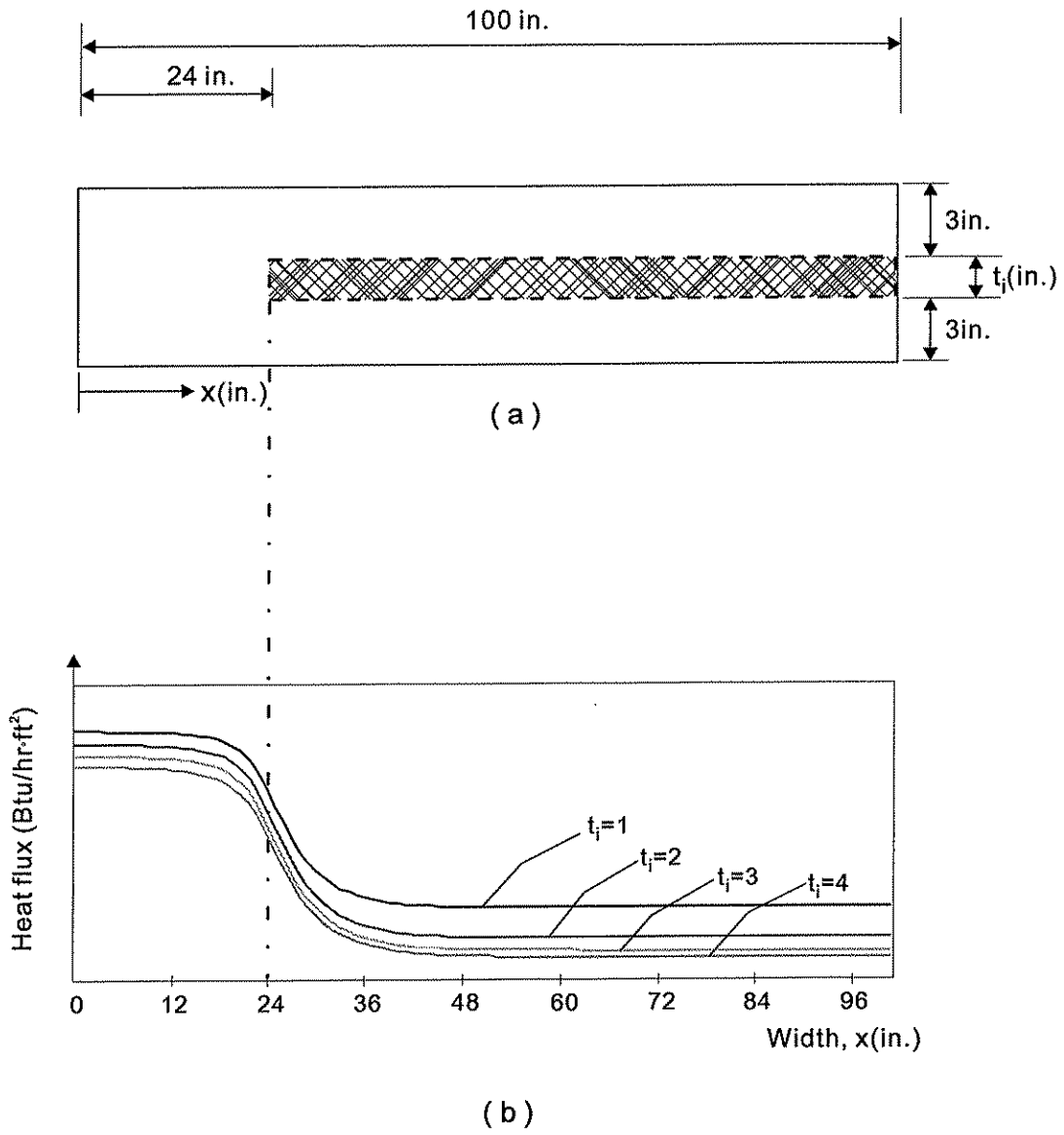

Figure 4.5 Effect of insulation thickness: (a) characteristic section; (b) heat flux along the width of the panel.

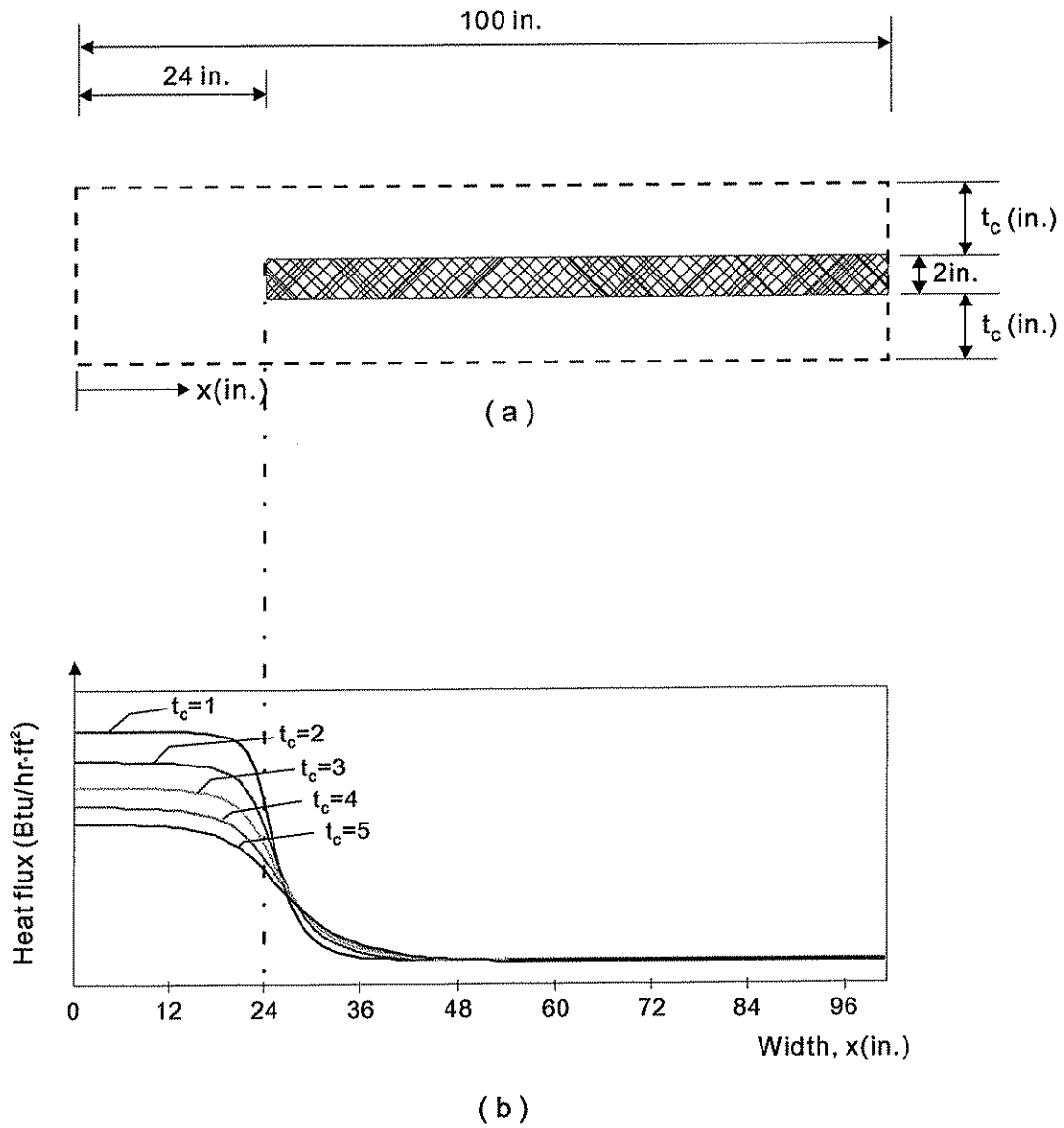

Figure 4.6 Effect of concrete thickness: (a) characteristic section; (b) heat flux along the width of the panel.

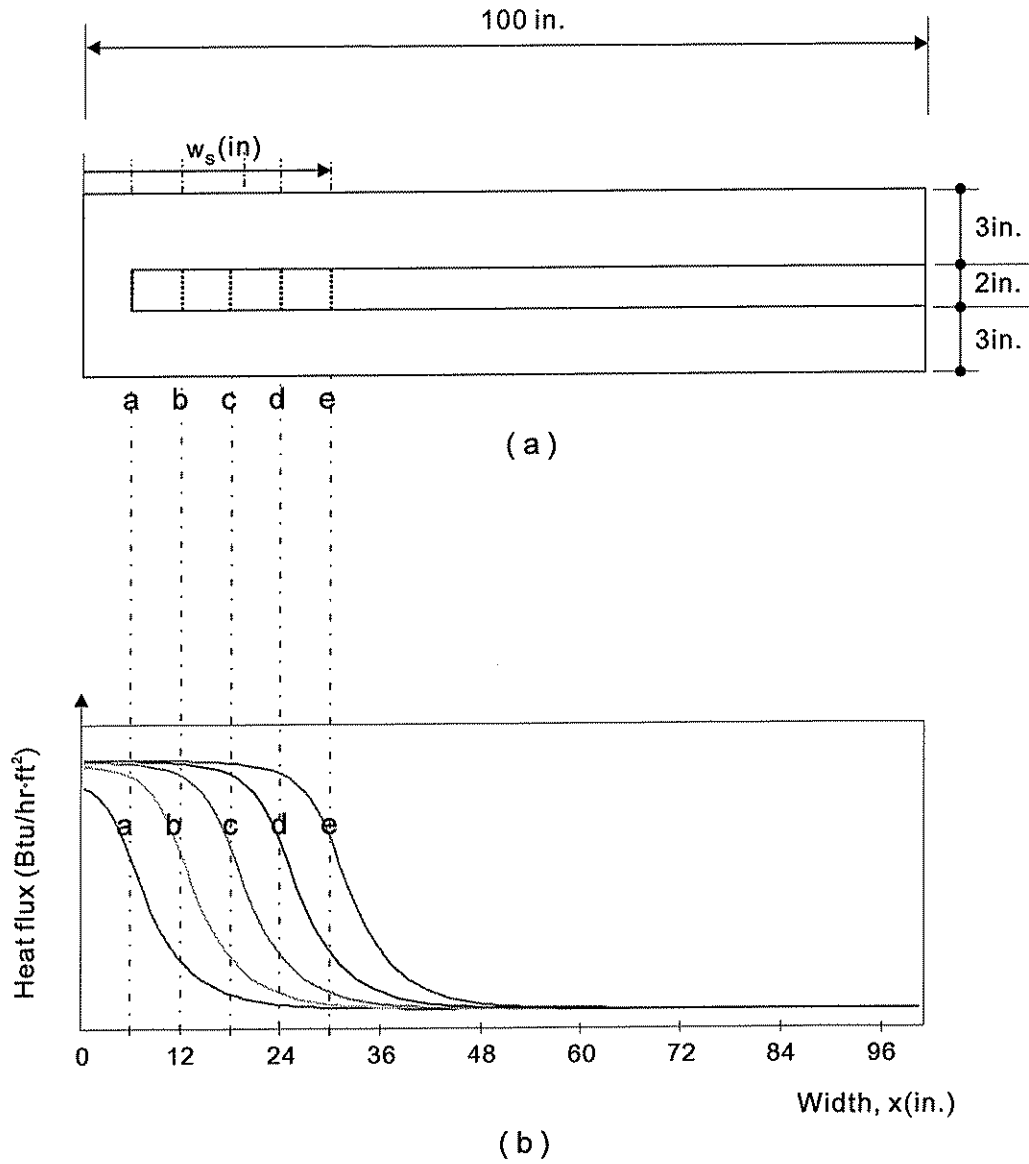

Figure 4.7 Effect of solid concrete width: (a) characteristic section; (b) heat flux along the width of the panel.

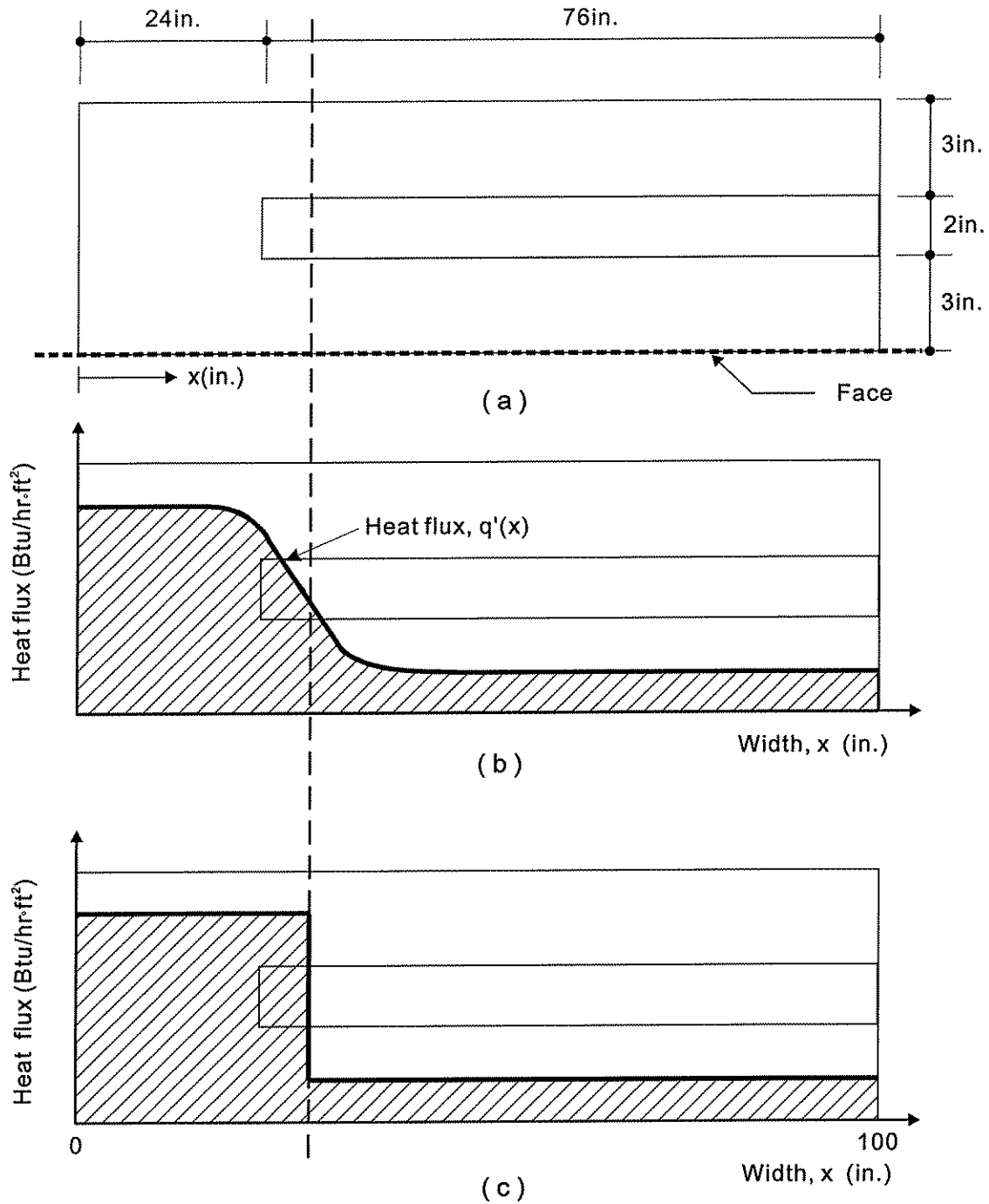
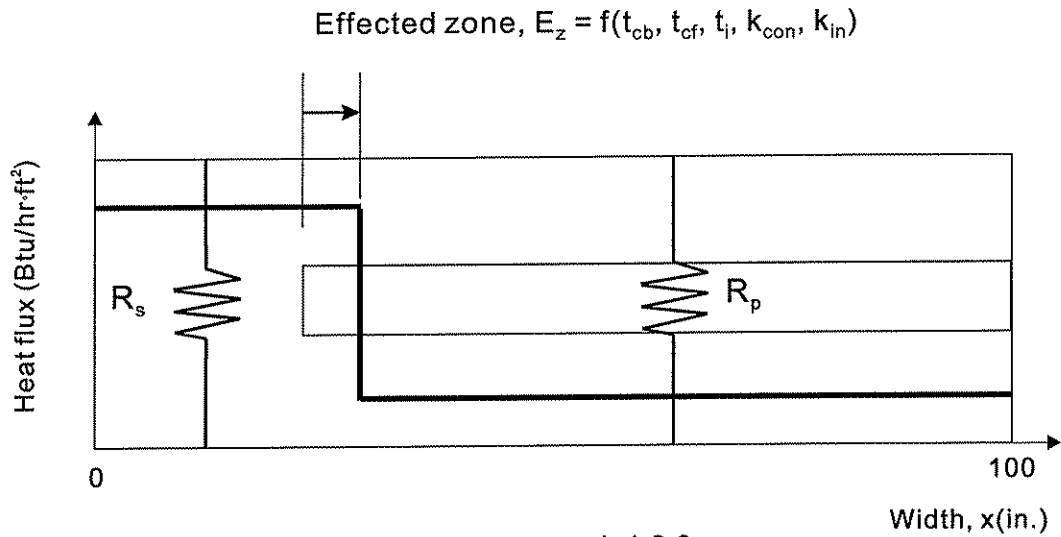

Figure 4.8 Heat flux through characteristic section: (a) specified characteristic section; (b) heat transfer rate along the face of the characteristic section; (c) simplified representation of heat flux.



$i=1$

$$U_{si} = \frac{k_i}{t_i}$$

$$R_{si} = \frac{1}{U_{si}}$$

$$R_s = \sum R_{si}$$

$$A'_s = \frac{A_s}{A_t}$$

$i=1,2,3$

$$U_{pi} = \frac{k_i}{t_i}$$

$$R_{pi} = \frac{1}{U_{pi}}$$

$$R_p = \sum R_{pi}$$

$$A'_p = \frac{A_p}{A_t}$$

$$\frac{1}{R} = \frac{A'_s}{R_s} + \frac{A'_p}{R_p}$$

Figure 4.9 Summary of Characteristic Section Method R-value calculation.



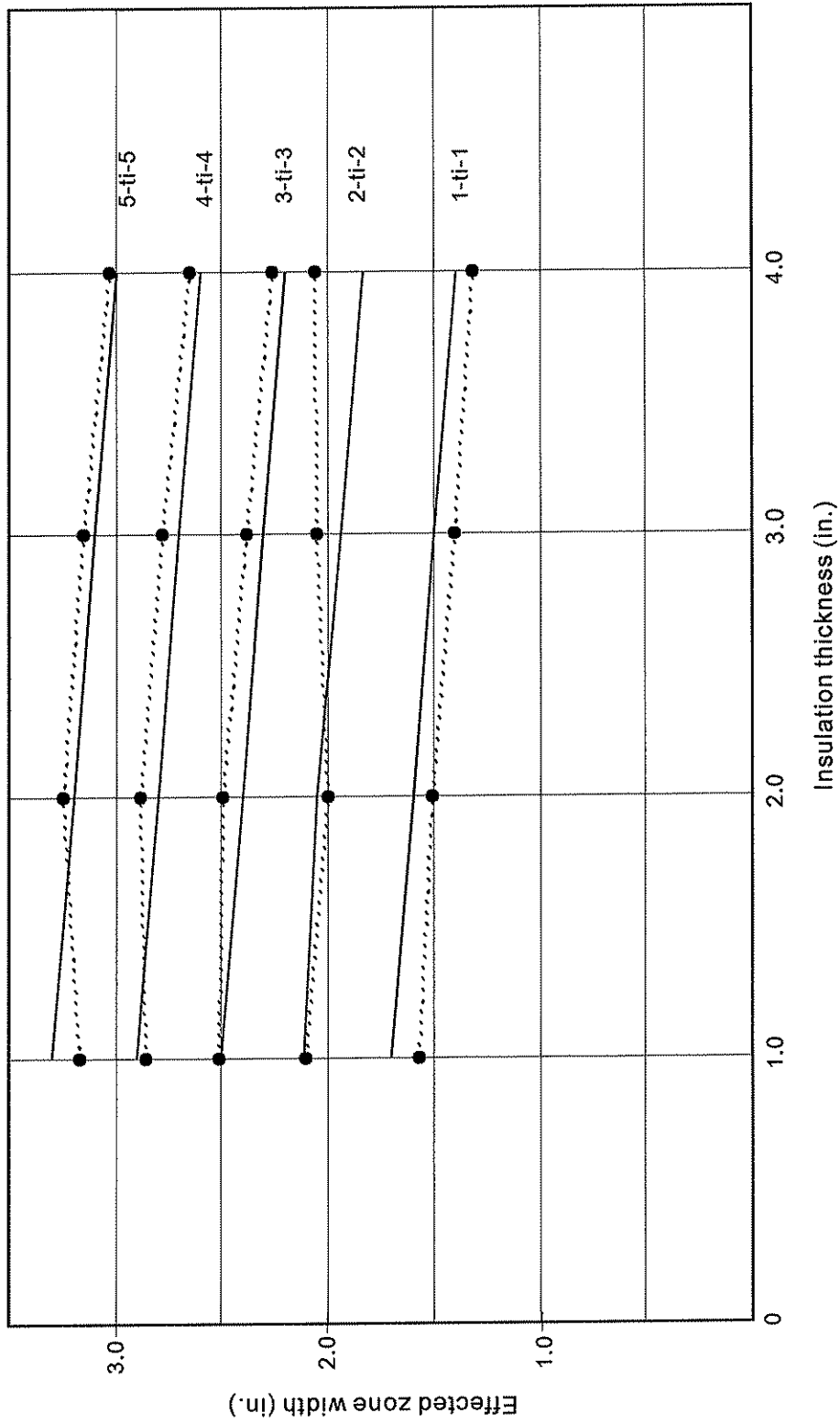

Figure 4.10 Variation in  $E_z$  with concrete wythe thickness and insulation layer thickness for symmetric characteristic sections.

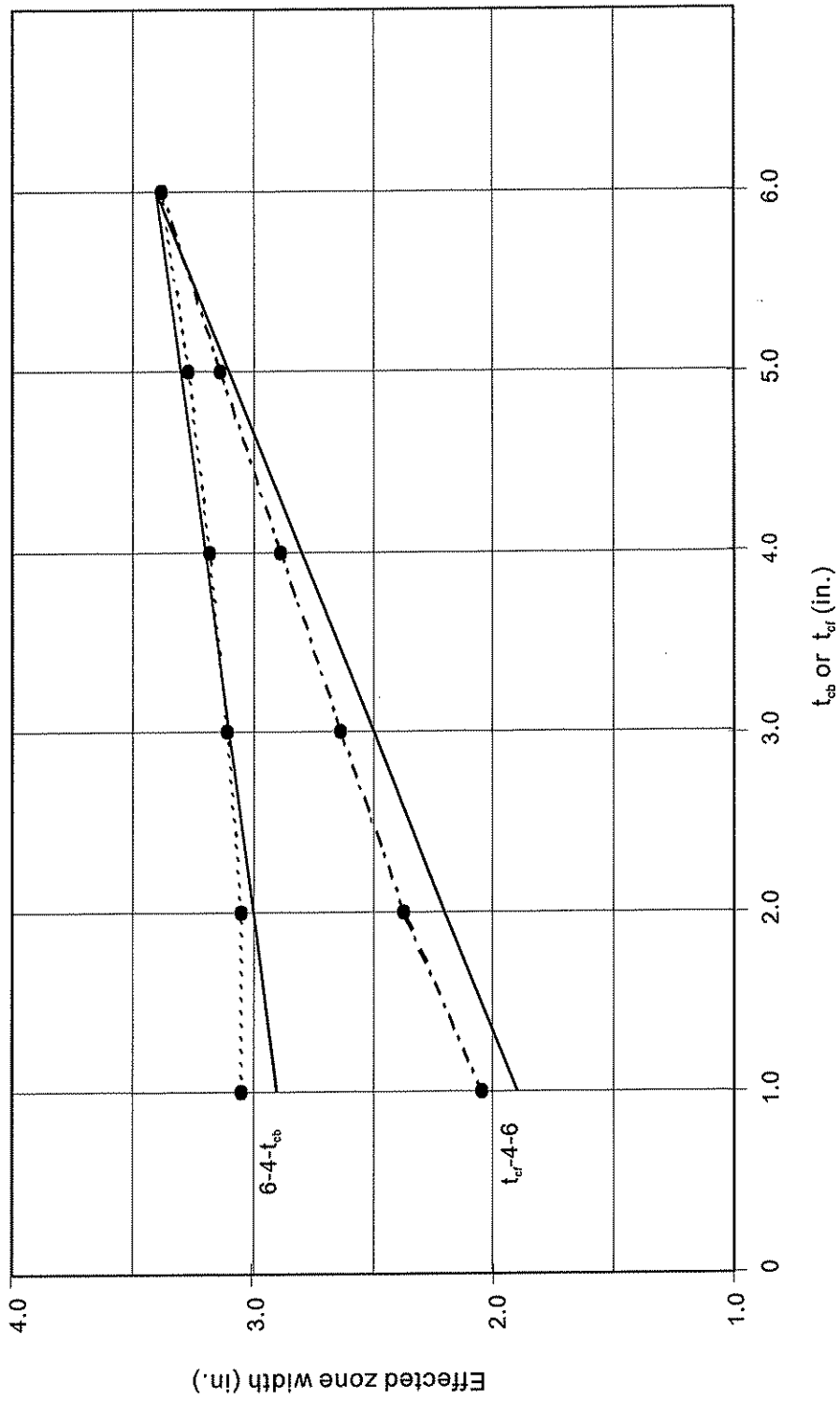

Figure 4.11 Variation in  $E_z$  with concrete wythe thickness for unsymmetric characteristic sections.

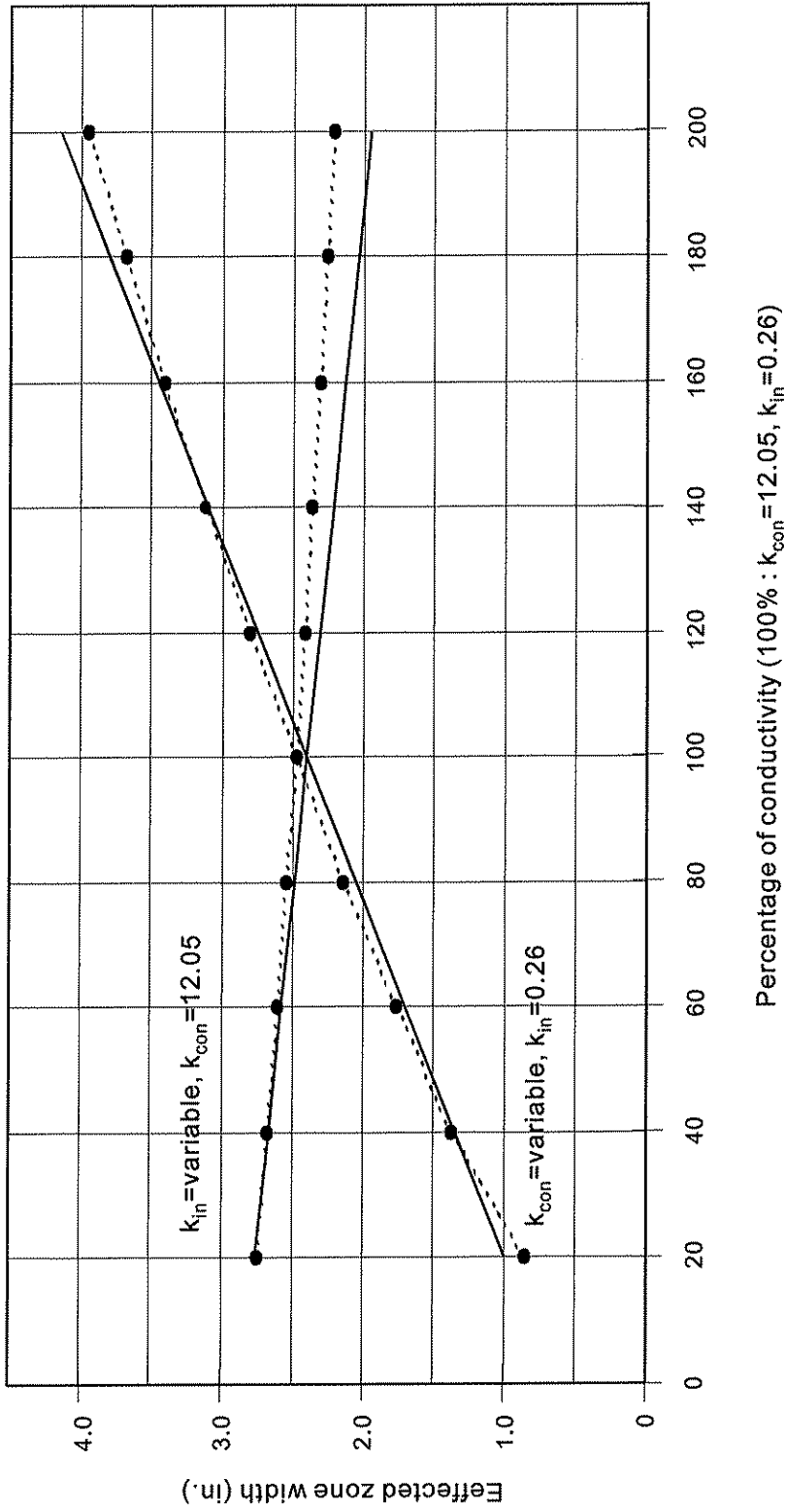

Figure 4.12 Variation in  $E_z$  with concrete and insulation thermal conductivities for a 3-2-3-24 characteristic section.

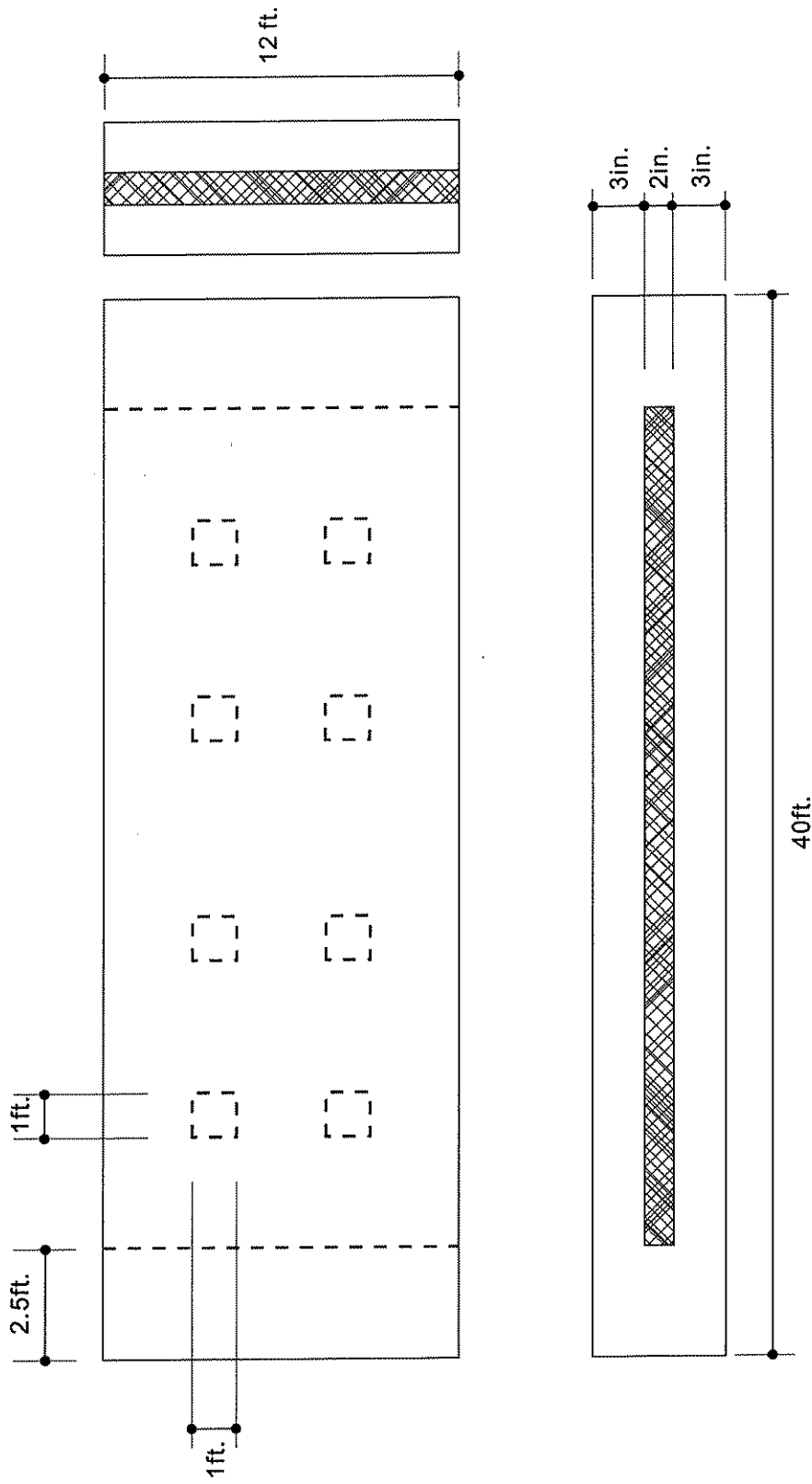

Figure 4.13 Typical precast concrete sandwich wall panels which is symmetric through its thickness.

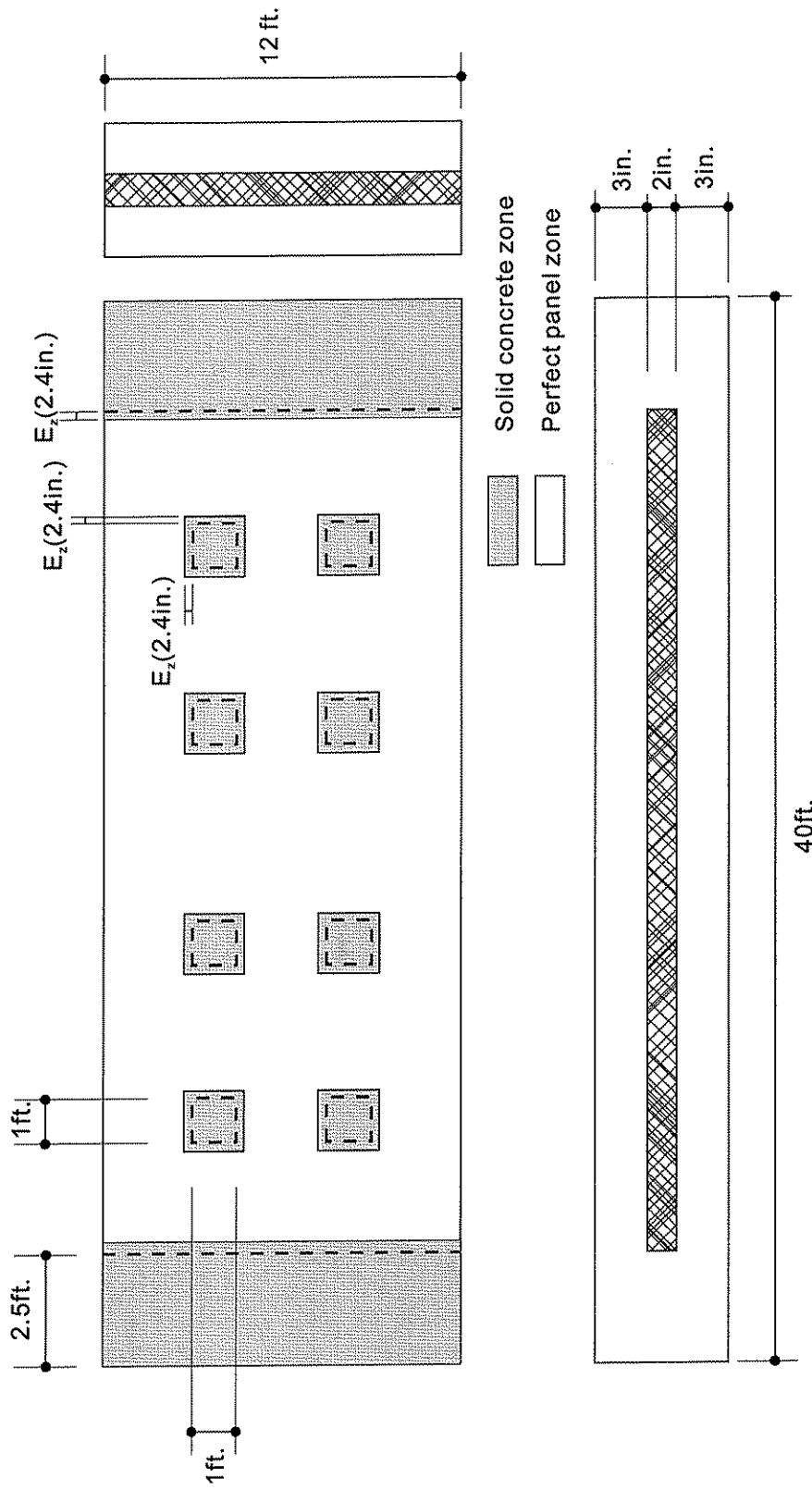
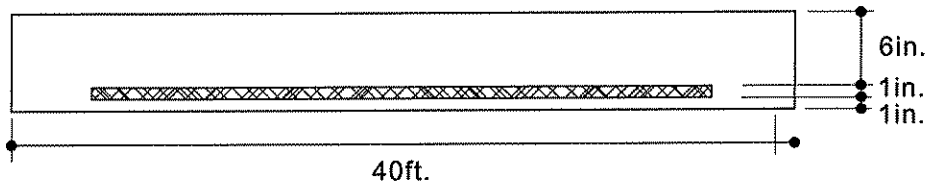
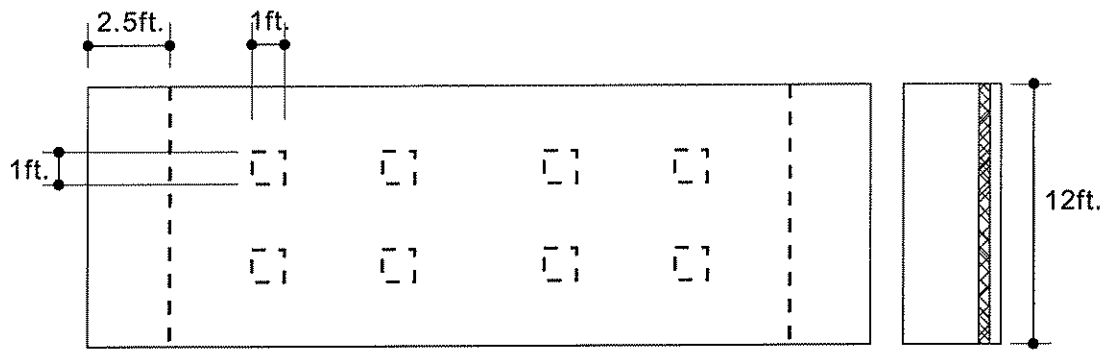
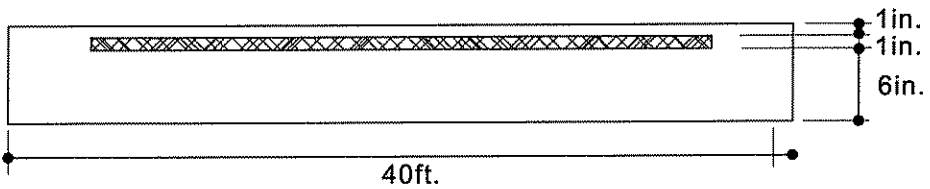
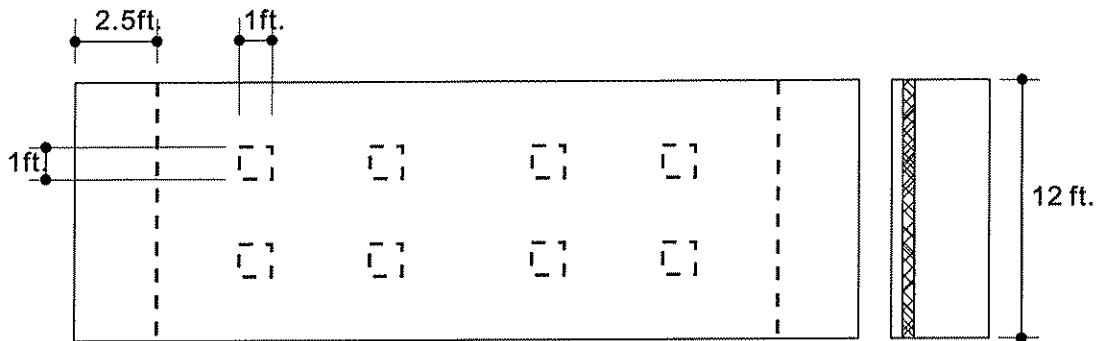

Figure 4.14 Typical precast concrete sandwich wall panel (same panel as Figure 4.14) showing solid concrete zones increased by  $E_z$ .



(a)



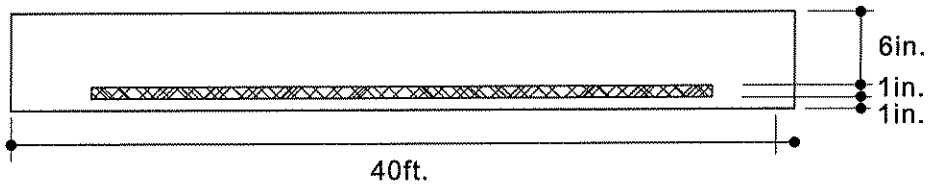
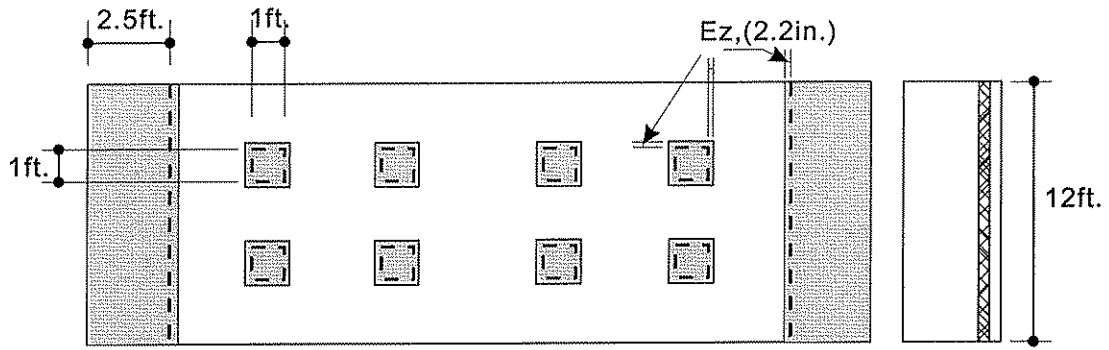

(b)

Figure 4.15 Typical precast concrete sandwich wall panels which are unsymmetric through the thickness:(a) 1-1-6 panel; (b) 6-1-1 panel.

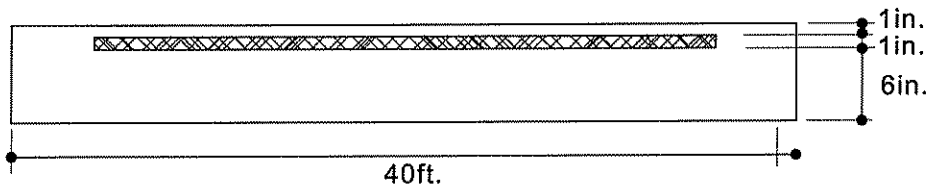
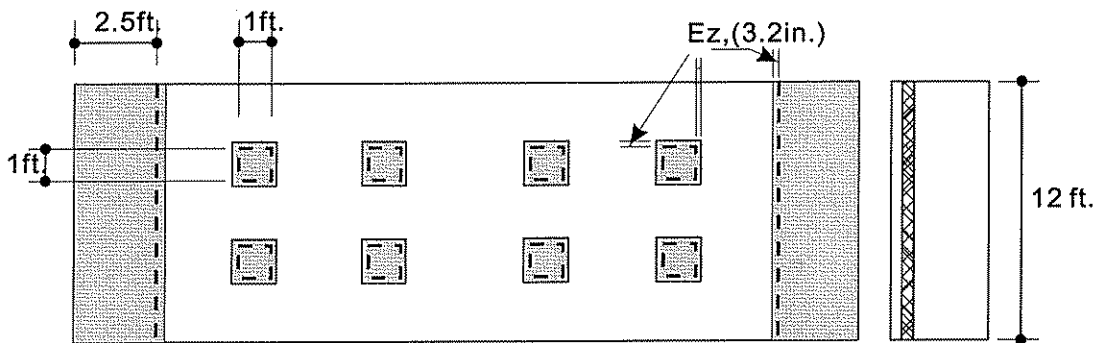

(a)



 Solid concrete zone  
 Perfect panel zone

(b)

Figure 4.16 Typical precast concrete sandwich wall panels (same panels as Figure 4.16) showing solid concrete zones increased by  $E_z$ : (a) 1-1-6 panel; (b) 6-1-1 panel.

## CHAPTER 5 SUMMARY AND FUTURE RESEARCH

### 5.1 SUMMARY

Precast concrete sandwich wall panels are used as exterior walls for many types of structures. These panels generally span vertically between foundations and floors or roofs, and provide the dual function of transferring wind load and providing thermal insulation for the structure. Sandwich wall panels are commonly composed of two concrete wythes separated by a layer of insulation. They often include solid concrete regions that extend through the entire thickness of the panel to place inserts for lifting and handling, and also to place hardware for connections to the foundation and adjacent panels. These solid concrete regions create thermal bridges which reduce the overall effectiveness of the insulation.

Present methods to estimate the thermal resistance, or R-value, of a sandwich panel include classical calculations methods such as the parallel flow and isothermal plane methods, physical tests, and finite element methods. The parallel flow and isothermal plane methods are shown to provide inaccurate results for sandwich wall panels. Physical tests to determine R-values are expensive to perform. Finite element methods can be cumbersome for routine use in design with currently available software.

A new simplified calculation method, called the Characteristic Section Method, is proposed to estimate R-values for precast concrete sandwich wall panels. The method was developed by studying the heat transfer through the characteristic section in a sandwich panel. The characteristic section is an assemblage of concrete and insulation in a geometrical configuration that occurs repeatedly throughout typical sandwich wall panels.

In the proposed Characteristic Section Method, the panel is divided in to two regions. The first region is treated as a perfectly insulated panel without any thermal bridge. The second region is treated as a solid concrete panel without any insulation. The total thermal resistance of the panel is calculated as the resistances of these two regions added together in parallel. The portion of the panel that is treated as a solid concrete panel without any insulation is larger than the actual solid concrete regions that exist in the panel. There is an effected zone around each solid concrete region that is added to the actual area of the solid concrete region to obtain the size of the concrete region used in the calculation. The width of the effected zone  $E_z$  is computed using Equations (4.1) through (4.4). These equations are developed to compute the width of the effected zone as a function of the thicknesses of the face wythe, back wythe, and insulation layer, and also as a function of the thermal conductivities of the concrete and insulation.



## **5.2 FUTURE RESEARCH**

Future research which may be performed includes the following:

1. The panels treated in this research included solid concrete zones that were spaced far enough apart that the effected zone regions did not overlap. Such panels are representative of most panels used in practice. Additional analyses should be performed for panels with more closely spaced solid concrete zones in which the effected zone regions may overlap to determine if the proposed method gives accurate results in those cases as well.
2. Additional analyses should be performed on panels with small solid concrete regions (relative to the concrete wythe thickness) to determine if the proposed method gives accurate results in these cases as well. In these cases, the heat flux through the solid concrete region may not reach the full value obtained by a larger solid concrete region. One example of this would be a three inch wide rib in a typical 3-2-3 panel.
3. Additional research is needed to determine if the Characteristic Section Method may be extended to the three-wythe panel.

## REFERENCE

American Society of Heating, Refrigerating and Air-Conditioning Engineers, Inc., ASHRAE Handbook – Fundamentals (I-P Ed.), New York, 1993.

American Society for Testing and Materials, ASTM C236-98: "Standard Test Method for Steady-State Thermal Performance of Building Assemblies by Means of a Guarded Hot Box," Philadelphia, PA, Vol. 04.06., 1992, pp. 53-63.

Computers & Structures, Inc., SAP 90 – Heat Transfer Analysis Users Manual, Berkeley, California, 1990.

Farouk, B., and Larson, D.C., "Thermal Performance of Insulated Wall Systems with Metal Studs," Proceedings of the 18th Intersociety of the Energy Conversion Engineering Conference, 1983, pp. 2003-2009.

Holman, J.P., Heat Transfer (5th Ed.), McGraw-Hill Book Company, 1981.

Incropera, F.P., and DeWitt, D.P., Fundamentals of Heat and Mass Transfer (4th Ed.), John Wiley & Sons, Inc., 1996.

Lee, B.J., and Pessiki, S, "Development of a Precast Prestressed Concrete Three-wythe Sandwich Wall Panel," Lehigh University, ATLSS Report 03-05, 2003, 294 pp.

McCall W.C., "Thermal Properties of Sandwich Panels," Concrete International, January 1985, pp.35-41.

PCI Committee on Precast Sandwich Wall Panels, "State-of-the-Art of Precast/Prestressed Sandwich Wall Panels," PCI Journal, March-April, 1997, pp.92-134.

PCI Design Handbook (5th Ed.), Precast / Prestressed Concrete Institute, Chicago, IL, 1999.

Snyder, M.K., "Heat Transfer Measurements of Corewall Insulated Sandwich: Prestressed Concrete Wall Panel System with 2-in. Thick Factory Installed 1-pcf Polystyrene Bead Board Insulation," Butler Manufacturing Company Research Center. Grandview, Missouri, 1980.