

Lehigh University Lehigh Preserve

Theses and Dissertations

2013

Using LIBS and Advanced Data Processing to Analyze Biomass and Coal Feedstock for Utility Boiler Applications

Tong Zhu
Lehigh University

Follow this and additional works at: <http://preserve.lehigh.edu/etd>

 Part of the [Mechanical Engineering Commons](#)

Recommended Citation

Zhu, Tong, "Using LIBS and Advanced Data Processing to Analyze Biomass and Coal Feedstock for Utility Boiler Applications" (2013). *Theses and Dissertations*. Paper 1704.

This Thesis is brought to you for free and open access by Lehigh Preserve. It has been accepted for inclusion in Theses and Dissertations by an authorized administrator of Lehigh Preserve. For more information, please contact preserve@lehigh.edu.

Using LIBS and Advanced Data Processing to Analyze Biomass and Coal Feedstock for Utility Boiler Applications

by

Tong Zhu

A Thesis

Presented to the Graduate and Research Committee

of Lehigh University

in Candidacy for the Degree of

Master of Science

in

Mechanical Engineering and Mechanics

Lehigh University

August 13rd, 2013

This document is an edited version of the full thesis, which resides in the archives of the Energy Research Center. Edits were made to protect sponsor's confidential information. The full thesis is available upon request.

Thesis is accepted and approved in partial fulfillment of the requirements for the Master of Science in Mechanical Engineering and Mechanics.

Date Approved

Dr. Edward K. Levy
Thesis Advisor

Dr. Carlos E. Romero
Thesis Co-Advisor

Dr. Gary Harlow
Department Chair

Acknowledgements

First, I would like to express my gratitude to all the academic and administrative staff at the Energy Research Center for giving me a lot of help during the writing of this thesis. I would like to thank my advisor and co-advisor, Prof. Edward Levy and Dr. Carlos Romero for their encouragement, guidance and help over the last three years. Also thanks to Zheng Yao for the help he gave to me. Finally I would like to express my deep gratitude to the personnel from the Energy Research Company for their collaboration during this project.

TABLE OF CONTENTS

LIST OF FIGURES	V
LIST OF TABLES	VI
ABSTRACT.....	1
CHAPTER 1: INTRODUCTION.....	2
1.1 PROBLEM STATEMENT AND LIBS.....	2
1.2 RESEARCH OBJECTIVE	4
CHAPTER 2: LITERATURE REVIEW	5
2.1 SLAGGING AND FOULING PHENOMENA	5
2.2 SLAGGING AND FOULING INDICES FOR BIOMASS CO-FIRING	6
2.3 LIBS APPLICATIONS	11
CHAPTER 3: EXPERIMENTAL INSTRUMENTATION AND SETUP	16
3.1 EXPERIMENTAL SETUP INTRODUCTION	16
3.2 EXPERIMENTAL SAMPLE PREPARATION	18
3.3 MEASUREMENT PROCEDURES	19
CHAPTER 4: LABORATORY EXPERIMENTAL RESULTS.....	20
CHAPTER 5: RESULTS	25
CHAPTER 6: CONCLUSIONS AND RECOMMENDATIONS	31
REFERENCES	32
VITA.....	35

LIST OF FIGURES

Figure 2.1: Slagging and Fouling in a Pulverized Fuel Boiler.....	5
Figure 2.2: Typical LIBS Experimental Setup.....	12
Figure 2.3: Typical LIBS Fiber-based Experimental Setup.....	12
Figure 3.1: LIBS System General Layout.....	16
Figure 3.2: Photograph of LIBS Analyzer Installed in ERCo's Laboratory.....	17
Figure 4.1: Calibration Plot for K (769.9 nm) Emission Line.....	22
Figure 4.2: Calibration Plot for Al (309.3 nm) Emission Line.....	22
Figure 4.3: Calibration Plot for Ca (422.7 nm) Emission Line.....	23
Figure 4.4: Calibration Plot for Fe (259.9 nm) Emission Line.....	23
Figure 4.5: Calibration Plots for Mg (285.2 nm) Emission Line.....	24
Figure 4.6: Calibration Plots for Na (589.0 nm) Emission Line.....	24
Figure 5.1: Results for Prediction of Al ₂ O ₃	26
Figure 5.2: Results for Prediction of CaO.....	26
Figure 5.3: Results for Prediction of Fe ₂ O ₃	26
Figure 5.4: Results for Prediction of K ₂ O.....	27
Figure 5.5: Results for Prediction of MgO.....	27
Figure 5.6: Results for Prediction of Na ₂ O.....	27
Figure 5.7: Results for Prediction of SiO ₂	28
Figure 5.8: Results for Prediction of TiO ₂	28
Figure 5.9: Prediction Results for Heating Value.....	29
Figure 5.10: Prediction Results for Initial Deformation Fusion Temperature (IDT).....	30

LIST OF TABLES

Table 2.1: Fouling Indices of Coal and Range of Values.....	10
Table 3.1: Material Sample Analysis.....	19
Table 4.1: S/B and S/N for Selected Atomic Emission Lines from Switchgrass Sample.....	21

Abstract

A study was undertaken to determine the feasibility of using advanced instrumentation and data processing to accurately predict in real-time the properties of biomass to be used as a supplemental fuel in coal-fired electric generating plants. Biomass use would reduce greenhouse gas emissions and also lower the fuel costs for a power plant. However, biomass properties are highly variable and not well characterized with a time scale that can be used for boiler operational control.

Laser Induced Breakdown Spectroscopy (LIBS) was the analytical technique used in this study to analyze samples of biomass and coal. Spectral data obtained with LIBS were processed using advanced data processing techniques to determine fuel properties of interest.

In this study, ash fusion temperature, high heating value, and ash mineral concentrations were measured. The results were highly successful by comparing the experimental results with independent laboratory analysis. All mineral results showed almost linear calibration curves with little data scatter. The heating value results, ranging from 6,620 Btu/lb to 13,080 Btu/lb, were obtained with root mean square error of approximately ± 15 Btu/lb. The initial deformation ash fusion temperature, ranging from $1,590^{\circ}F$ to $2,800^{\circ}F$, has a root mean square deviation of approximately $\pm 33.34^{\circ}F$. These results showed that even under significant property variations, the combined application of LIBS and advanced data processing provides results that a power plant operator could use to mitigate problems in boilers fired with biomass and coal, which originate from the fuel quality variability of the feedstock.

Chapter 1: Introduction

1.1 Problem Statement and LIBS

The growing interest in global warming due to carbon dioxide emissions has drawn attention to the use of biomass as feedstock for electricity production [1]. The use of biomass energy, compared to other sustainable energy sources, has been proposed as an effective method of reducing net greenhouse gas emissions since the carbon in biomass is part of the active carbon cycle [2]. Biomass combustion and biomass/coal co-firing, both in retrofit and for new plants, are expected to considerably increase worldwide in the foreseeing future. According to a recent inventory on the application of biomass co-firing worldwide [3], more than 80 coal-fired power plants have experience with biomass co-firing, in a range from approximately 50 MW_e to 700 MW_e . By now, much of the biomass co-firing in large coal-fired boilers has been at relatively low co-firing ratios, up to 20% by heat input to limit the impact on plant performance.

The applicability of biomass co-firing with coal partly depends on its impact on ash deposition which can have important impact on boiler operations, boiler efficiency, and corrosion of heat transfer surfaces. Ash deposition on heat transfer surfaces (commonly referred as slagging and fouling) is a very important issue for solid fuel-fired boilers, and more importantly for biomass combustion. Slagging refers to bulk ash deposition that occurs at the high temperature areas of the boiler, where radiant heat is relevant. Fouling refers to condensation of gases compounds in the flue gas on convective pass heat transfer surfaces, which poses high sintering strength. There is a large number of research papers on the characteristics of coal ash deposits, but there is relatively limited literature on the coal-biomass ash deposits. Coal/biomass co-combustion has the potential to create ash deposition problems because of the inorganic composition (high alkali levels) and mode of occurrence of inorganic species (mostly mobile forms) in biomass [4]. This results in increased slagging and fouling propensity when co-firing biomass with coal, in comparison to the base case of coal firing by itself.

Ash fusion temperature (AFT) of solid fuels has been traditionally regarded as a useful slagging indicator. Typically, fuels with a low ash fusion temperature would result

in formation of plastic deposits that would accumulate on the upper boiler heat transfer surfaces, leading to high rate of slagging. It is widely acknowledged that the chemical composition of coal and biomass is influential in determining its ash fusion temperature. However, determination of ash fusion temperature from the fuel ash elemental composition is a complicated problem because the relationship between the interacting factors is not well understood [5]. There are several traditional methods to estimate the ash fusion temperatures from elemental ash analysis [6, 7]. Most of those methods rely on statistical analysis.

Prediction of and on-line detection of slagging and fouling propensity would help optimize plant operation, increase plant availability and lower maintenance requirements, for biomass/coal co-firing power plants. Typically, plants that fire coal (and also biomass/coal blends) rely on periodical sampling and laboratory analysis of fuel samples to determine the potential slagging and fouling impact of the fuels and to anticipate way to mitigate the impact. This approach has limited effectiveness, since that fuel variability, which directly impacts slagging and fouling, changes more rapidly than the frequency of the fuel analysis, making it almost impossible to optimize plant operation in relation to fuel quality at an appropriate time scale. Laser induced breakdown spectroscopy (LIBS) could be applied as an in-situ detection technique for coal-biomass co-firing applications and help with slagging/fouling mitigation [8]. LIBS is a technology which uses a high density pulsed laser to induce a plasma from a sample by focusing onto its surface. The emitted light from the laser-induced plasma (LIP) can be collected and applied to elemental analysis by means of emission spectroscopy. Many elements present in the coal or biomass, such as Al, Ca, Mg, Na, Fe, Si, K and Ti can be traced by a LIBS system [9].

There are many advantages of using LIBS, as compared to other on-line detection technologies for solid fuel characterization. The LIBS measurement is based on a straightforward method that makes unnecessary to prepare the sample in advance. Furthermore, LIBS instrumentation can be designed for various applications and compact portable systems are commercial now. More importantly, LIBS measurements results can be made almost instantaneously which makes it an attracting method for solid fuel analysis in power plants.

1.2 Research Objective

This thesis reports a study performed to demonstrate the feasibility of using LIBS and advanced data processing for prediction of coal and biomass elemental composition, and accordingly to estimate their slagging propensity. In this study, two coals, eleven biomass materials and three coal/biomass blends, with different elemental compositions and slagging potentials, were tested by a LIBS system in the laboratory. The collected data were then processed to develop calibration curves for the sample elemental composition determination. Fuel heating value was also modeled and predicted. The information could then be supplied in real time to boiler plant operators to optimize relevant operation parameters that could help alleviate boiler slagging problems whereas firing or co-firing with biomass.

Chapter 2: Literature Review

This literature review includes detailed descriptions of slagging and fouling phenomena, slagging and fouling indices for biomass co-firing, the LIBS technique, and applications of artificial neural networks.

2.1 Slagging and Fouling Phenomena

Slagging and fouling are two of the biggest problems in solid fuel fired boilers, which are caused by deposit deposition on heat transfer surfaces, especially for biomass combustion. There are two basic forms of ash deposits: molten ash and alkali salts. The molten ash particles are called slag and occur mainly on furnace walls and convection surfaces exposed to radiant heat. The alkali salts are generally referred as fouling, occurring on convection heat surface such as the superheater and reheater [10].

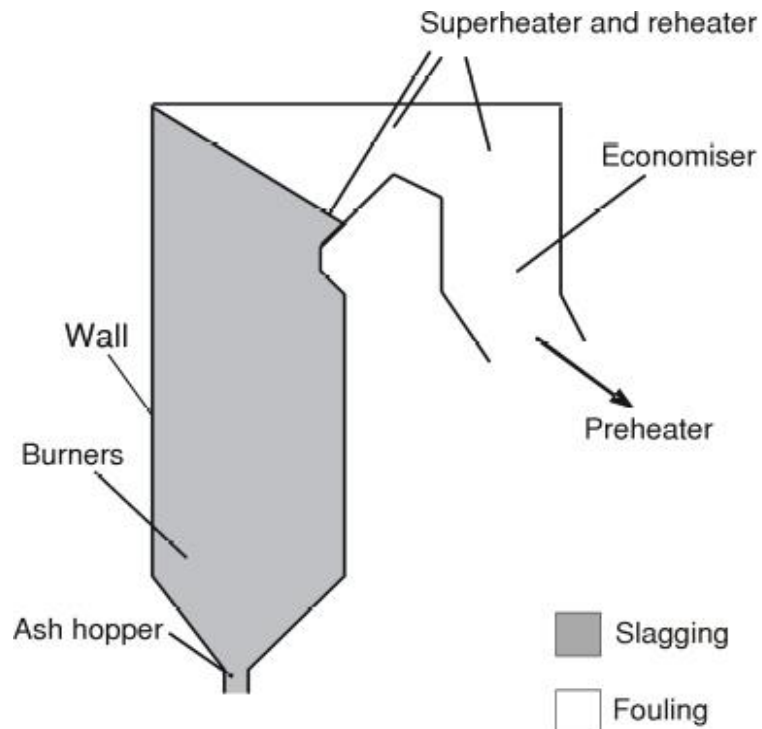

Figure 2.1: Slagging and Fouling in a Pulverized Fuel Boiler [1]

The molten ash deposits which build up on the furnace walls are called wall slag. The furnace walls of coal fired boilers consist of membranes that connect the water pipes through which water flows. Heat from the combustion process boils this water to steam which absorbs half of the combustion heat release. Most boilers have some degree of wall slag which does not necessarily cause problems. Generally, the amount of slag is controlled by applying air, steam or water soot blowers. When the amount of slag becomes excessive, problems can occur.

Excessive wall slag causes the following problems [11]:

1. Wall slag would flow to the bottom of the furnace, cool and plug the opening situated there. The ash would eventually bridge over, sealing off the bottom boiler outlet for bottom ash removal.
2. Wall slag would act as an insulator and impede heat transfer to the water. This would increase the furnace exit gas temperature (FEGT) and further allow molten ash to deposit in the superheater and convection pass regions.
3. Slag would build up around the burner area, called eyebrows, interfering with coal and air flows. This type of buildup can cause damage to the burners, among other things.

The molten deposits sticking at the superheater sections are called superheater slag. It is when this slag bridges across the fuse spacing that the deposits become troublesome. The bridged slag reduces the cross sectional area of the flue gas to flow through. As the slag grows in size, the flue gas velocity increases and the decreased heat transfer due to the slag insulating the tubes would cause slag buildup in the next section of the convection pass.

Alkali sulfates, primarily $CaSO_4$ and Na_2SO_4 which can bond with fly ash particles are the main cause of fouling. Fouling tends to form in the convective pass of boilers, particularly the reheater, horizontal superheater and the economizer sections.

2.2 Slagging and Fouling Indices for Biomass Co-firing

It is clear that ash deposition occurring in the furnace and boiler heat transfer surfaces is a complex phenomenon. The process occurs over a wide range of flue gas and surface temperatures, and is dependent both on the characteristics of the ash and on the

design and operating conditions of the boiler. This is complicated when biomass is introduced as a secondary fuel in existing coal-fired boilers. Biomass co-firing with coal has the potential to cause ash deposition problems because of its high alkali levels and inorganic species, compared to many coals. These differences will increase ash deposition and fouling of boiler tubes. The feasibility of coal-biomass co-firing depends, in part, on this impact on ash deposition.

A number of slagging and fouling indices are available for the assessment of the propensity of fuel ashes to form deposits, mainly in combustors and furnaces. A detailed description of the technical basis and use of these indices is presented in Raask (1985). These indices are based either on the fuel ash content and the ash chemical composition, or on the ash fusion temperatures. These indices have been developed mainly for the assessment of coals, and are applied, with appropriate modifications, to other solid fuels, including wastes and biomass materials, and to the mixed ashes produced by the co-processing of biomass materials with coal [12].

One of the most commonly used high temperature slagging prediction indices is the ratio of the acidic metal oxides (SiO_2 , Al_2O_3 and TiO_2) to the basic oxides (Fe_2O_3 , CaO , MgO , Na_2O and K_2O), which was presented by Attig and Duzy [13]:

$$Base = Fe_2O_3 + CaO + MgO + Na_2O + K_2O$$

$$Acid = SiO_2 + Al_2O_3 + TiO_2$$

$$R_{b/a} = Base / Acid$$

When the $R_{b/a}$ value is lower than 0.5, it has been suggested a light slagging; when the $R_{b/a}$ value is between 0.5-1.0, it stands for medium slagging; when the $R_{b/a}$ value is between 1.0-1.75 it may lead to high slagging; and when the $R_{b/a}$ value is greater than 1.75, the slagging is severe.

Another widely used index is the silica ratio, which is described by Winegartner [14],

$$Silica\% = \frac{SiO_2}{SiO_2 + Fe_2O_3^* + CaO + MgO} * 100\%$$

The slagging potential in terms of the silica ratio is defined when the silica ratio is higher than 72%, slagging is light; when the silica ratio is from 65% to 72%, medium to high slagging takes place; and when the silica ratio is lower than 65%, it may lead to severe slagging.

For the co-firing of biomass at relatively low levels, the mixed ash is still predominantly an alumino-silicate system and the normal coal slagging assessment methods previous described can be applied, with some level of confidence.

Another significant slagging index is the ash fusion temperature (AFT). AFT of fuels is one of the parameters most widely used in the assessment of feedstocks quality, ash fusibility and melting characteristics. To best represent the AFT as a slagging index, a combination of initial deformation temperature (IT) and hemisphere temperature (HT) is used [15]:

$$F_s = \frac{4IT + HT}{5}$$

When F_s is higher than $2,449^\circ F$, the boiler slagging is slight; when F_s is between $2,250$ and $2,449^\circ F$, the slagging is medium; when F_s is between $1,926$ and $2,250^\circ F$, there is high slagging properties, and when F_s is lower than $1,926^\circ F$, the slagging is severe.

There have been various studies on the correlation between ash chemical composition and ash fusion temperature given by laboratory analyses for biomass and biomass-coal blends. Yanqin Niu, et al. [16] conducted a study on fusion characteristics of biomass ash. The ash fusion characteristics of capsicum stalks ashes, cotton stalks ashes and wheat stalks ashes were studied in a thermo gravimetric approach. It was found that initial deformation temperatures increase with decreased K_2O and increase with increased MgO , CaO , Fe_2O_3 and Al_2O_3 . The softening temperature, hemispherical temperature and fluid temperature of the ashes were not affected by the concentrations of each element and the experimental ashing temperature. Therefore, the deformation temperature could be used as an evaluation index of biomass deposition characteristics.

In a research conducted by Q.H. Li, et al. [17], actual and simulated biomass ashes were used to study their ash fusion temperature. Nine typical biomass fuels ashed at

1076 °F and 1499 °F were employed to investigate their ash fusion temperatures. By changing the ash composition and studying the influence of composition on fusion temperatures, twenty-seven simulated ashes were prepared with mixtures of organic and inorganic oxides for the ash fusion tests. The results showed that SiO_2 and Al_2O_3 are all favorable to increase the ash fusion temperature. Al_2O_3 is more effective than SiO_2 in reducing the slagging tendency. It was inferred that slightly adding Al_2O_3 can strongly improve the operational condition for slagging-mitigated biomass combustion. It was concluded in this study that the effect of base to acid ratio, $R_{b/a}$ on the deformation temperature is related to the initial deformation temperature of the ash. The initial deformation temperature decreases with $R_{b/a}$, increasing if the $R_{b/a}$ is less than 1.4.

Seggiani [18] conducted a study on empirical correlations for ash fusion temperatures for coal and biomass ashes. In this study, empirical correlations were derived by regression analysis to calculate the ash fusion temperatures under reducing conditions from the ash chemical composition. The database used in this work includes about 300 ash samples from coals of different sources and different biomass feedstock. Forty-nine independent parameters were considered in this regression analysis, which include the nine oxides normally analyzed on a SO_3 free basis. The deviations of the correlations were in the range between 113 °F and 176 °F, which fall within the experimental errors of the measurements, indicating that biomass elemental composition can be used with good accuracy to correlate biomass ash fusion temperatures.

When considering the potential slagging behavior of mixed ashes from co-firing biomass with coal, it is evident that, besides SiO_2 , all of the significant components of most biomass ashes, principally the alkali and alkaline earth metals, are powerful fluxing agents affecting the blended fuel ash fusion temperatures. It is expected, therefore, that co-firing with biomass will result in a reduction in ash fusion temperatures, and hence an increase in the slagging potential. This will certainly depend on the level of fluxing agents in the coal and on the co-fired ratio. The effect will be more dramatic when biomass is co-fired with coals with high fusion temperature ashes.

Mastalerz et al., [19] have proposed several fouling indices for coal ashes, as shown:

Table 2.1: Fouling Indices of Coal and Range of Values

Fouling Indices	Boiler Fouling		
	Low	Medium	High
$\left(\frac{Base}{Acid}\right) * Na_2O$	<0.2	0.2~0.5	>0.5
$Na_2O + 0.659K_2O$	<0.3	0.3~0.5	>0.5
$\% Na_2O$	<0.5	0.5~1	>1
$\% Cl$	<0.3	0.3~0.5	>0.5
$\frac{\% SiO_2}{\% Al_2O_3}$	<2	>2	

From Table 2.1, it can be seen that fouling indices for coal ashes are mainly based on the sodium content of the fuel. The deposition of sodium compounds by a volatilization/condensation mechanism is considered to be the principal driving force for convective pass fouling in coal-fired plants. Potassium in coal ash is principally present as a constituent of the clay minerals, and is not usually considered to be available for release by volatilization in the flame. For most biomass materials, potassium tends to be the dominant alkali metal, and is generally in a form that is available for release by volatilization. The fouling indices for biomass materials tend, therefore, to be based on the total alkali content of the fuel (Miles et al. 1995).

Overall, the majority of the studies reported in this chapter were originally developed and applied for the characterization of coals and their behavior in combustion systems. Because they are already in use within the power industry, many of these methods have been adapted for use with biomass materials, and for gasification and pyrolysis systems as well as combustors. As always, the application of methodologies to materials and processes for which they were not designed (such as biomass, or biomass and coal blends) should be done with caution.

2.3 LIBS Applications

Laser-induced breakdown spectroscopy (LIBS) is a technique based on atomic emission spectroscopy, which utilized a highly energetic laser pulse as the excitation source. LIBS can analyze any material sample regardless of its physics state, be it solid, liquid or gas. Even slurries, aerosols, and gels can be readily investigated with LIBS. Because all elements emit light when excited to sufficiently high temperatures, in theory, LIBS can detect all elements, limited only by the power of the laser, as well as the sensitivity and wavelength range of the spectrometer and detector.

Laser-induced breakdown spectroscopy operates by focusing the laser onto a small area at the surface of the specimen. When the laser is discharged, it ablates a very small amount of material which generates a plasma plume with temperatures in excess of $180,000^{\circ}F$. During data collection, typically after local thermodynamic equilibrium is established, plasma temperatures range from $8,541 - 35,541^{\circ}F$ [20]. At these temperatures, the ablated material dissociates into excited ionic and atomic species. At this point the characteristic atomic emission lines of the elements can be observed.

A LIBS system typically consists of a neodymium doped yttrium aluminum garnet solid-state laser, optics for focusing the laser energy onto a sample surface and for delivering the light produced during the LIBS reaction event to a detector with a wide spectral range and a high sensitivity, fast response rate and time gated operator. This is coupled to a computer which can rapidly process and interpret the acquired data. As such, LIBS is one of the most experimentally simple spectroscopic analytical techniques, making it one of the most cost effective techniques to operate.

A typical LIBS experimental setup [21] is shown in Figure 2.2, and a typical LIBS fiber optic based experimental setup is shown as Figure 2.3.

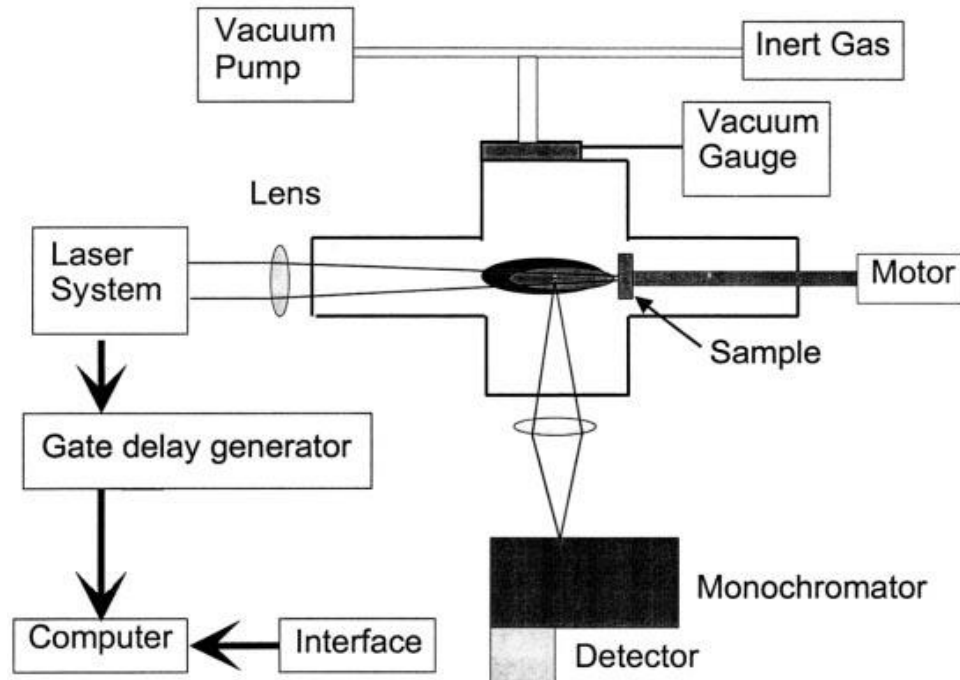

Figure 2.2: Typical LIBS Experimental Setup

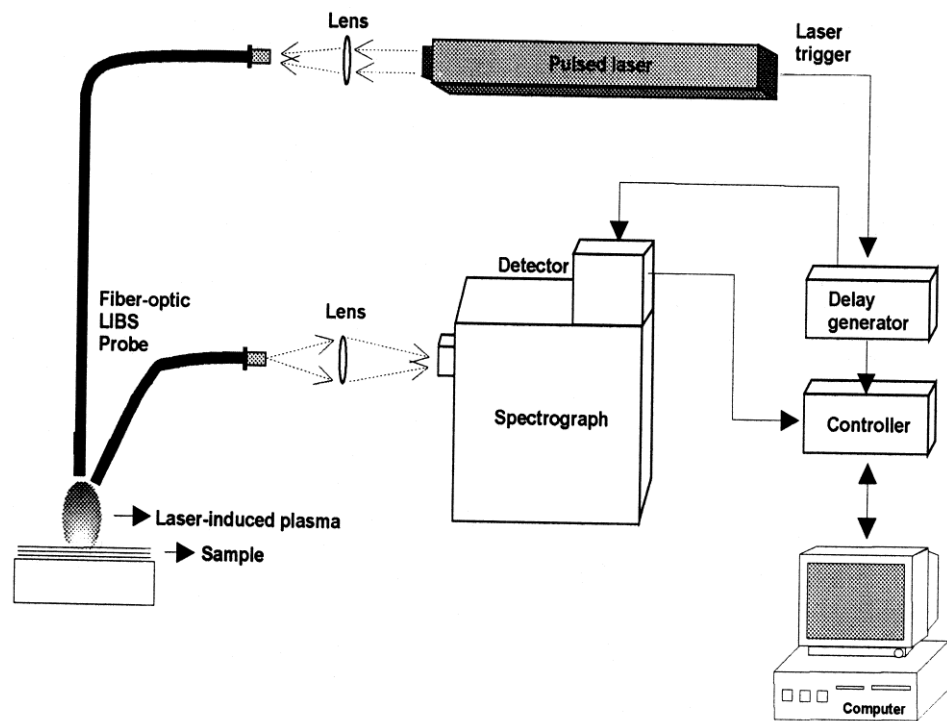

Figure 2.3: Typical LIBS Fiber-based Experimental Setup

In order to investigate the feasibility of using LIBS for biomass, coal and biomass-coal blends analysis and infer the slagging propensity of biomass and coal mixtures, it would be very important to review previous studies conducted in this area. There are many practical studies related to the application of LIBS for coal-fired power plants. The use of LIBS for biomass co-firing power plants is still in incipience.

In a study by Wangbao [22], a LIBS system was designed for on-line quality analysis of pulverized coal in power plants. The LIBS system, provided for direct measurement for C, H, Si, Na, Mg, Fe, Al, and Ti with measurement errors of less than 10% for pulverized coal. In this investigation, a LIBS system comprising of a LIBS apparatus and sampling equipment developed for application in a real power plant was described. References 26 demonstrated the feasibility of implementing the LIBS technique for in-situ characterization of pulverized coal.

For coal analysis, Ottesen [23] showed a preliminary application of LIBS for determining the composition of the inorganic coal constituents, such as Si, Al, Fe, Ca, Mg, K, Na, Ti in a combustion environment. Several aspects of the technique were discussed: (1) the plasma excitation process; (2) experimental intensities and methods of calculating elemental composition; and (3) the comparison of particle-by-particle results with average bulk chemical analyses and scanning electron microscopy data. This work reports the first direct experimental comparison of composition on a particle-by-particle basis with grain-by-grain determination of elemental ash composition.

In a research conducted by Bruce Chadwick and Doug Body [24], an instrumentation variation on LIBS was developed and applied for the operation at a power generating company. The instrument design allows simultaneous determination of all detectable elements using a multiple spectrograph and a synchronized, multiple charge-coupled device (CCD) spectral acquisition system. Independent testing of the instrument showed good correlation between the routine LIBS analysis and the analysis of the coal via acid extraction techniques for key ash-forming elements. It was shown that the LIBS instrumentation could yield sufficient accuracy and repeatability for commercial application in lignite-fired power stations. They also provided a long term assessment of LIBS in an industrial environment. Reference 28 concludes that for power

stations using this technology, the forecast analytical cost saving are in the vicinity of US \$100,000 per year enabling the power station to recover the capital cost of the equipment within nine months. In addition, the rapid analysis of LIBS enables further saving via better supervision of plant operations resulting in potentially fewer unscheduled shut-downs.

Stankova et al. [25] used a simple and cost effective LIBS system to make an evaluation of quantitative analysis capacities of major elements (Ca, Al, Mg, Si and Fe) present in fly ashes. Concentrations obtained by the LIBS were compared to wet acid digestion and alkali fusion followed by inductively coupled plasma optical emission spectrometry (ICP-OES) analysis. Ca, Mg, Fe, Si and Al concentrations found using the LIBS method were in a good agreement with the values obtained by classical methods. The method in this study is quite promising as the sample preparation of fly ashes for LIBS analysis is simple and fast and the LIBS spectra recorded in a few seconds.

Romero et al. [26] used LIBS for coal characterization and assessing slagging propensity. LIBS and neural networks were used to characterize elemental composition of coal samples and estimate the initial deformation ash fusion temperatures. A coal inventory was assembled with a range of slagging characteristics and fusion temperatures from 1751 to 2696 °F. The LIBS system achieved elemental composition measurement accuracy within ±15% (absolute). The LIBS system was tested off-line at a power plant on three different coals. The field results indicate an average relative fusion temperature prediction error when compared to American Society for Testing and Materials (ASTM) standardized measurements of ±132.8 °F, and an average precision for the LIBS measurements of ±57.2 °F.

Li et al. [27] from The State Key Laboratory for Coal Combustion in China, studied the effects of experimental parameters on elemental analysis of coal by LIBS, with the purpose to improve its precision. Organic components such as C, H, O, N and inorganic components such as Ca, Mg, Fe, Al, Si, Ti, Na, and K of coal was targeted. The experimental parameters such as the sample operation mode, and ambient gas were investigated and the optimum parameters which improved the precision of LIBS measurement were obtained. The relative standard deviation of the emission lines

intensities obtained from the elements in the coal samples were smaller than 10%. It was shown that the precision of elemental analysis of coal by LIBS can be improved by using the proper experimental parameters.

In a study by Blevins et al. [28], LIBS was applied near the superheater of an electric power generation boiler burning biomass, coal, or both. Elements detected include Na, K, Ca, Mg, C, B, Si, Mn, Al, Fe, Rb, Cl, and Ti. In this research, a full-scale testing was performed in a stoker-fired traveling grate boiler. The purpose of testing the power generation boiler was to use LIBS results to examine the differences in relative slagging potentials of various fuels. The Si, Na, Ca, Mg, and Ti concentrations were generally similar when firing coal and when with fiber cane, whereas the K, Al, and Fe concentrations were generally noticeably higher for fiber cane co-firing than for coal burning. The fluctuation levels were generally larger for the biomass co-firing tests than for the coal tests. This result was expected because the biomass fuels contained significantly more moisture than the coal.

In additional research by Blevins [29], LIBS was used to detect Si, Al, Ti, Fe, Ca, Mg, Na, P concentrations near the superheater section during co-firing tests which were conducted at a pilot-scale reactor at Sandia National Laboratories and in a boiler at the Hawaiian Commercial & Sugar Factory At Puunene, Hawaii. Combustion tests were performed, using Australian coal and whole fiber cane, including tops and leaves processed at three different levels, and fiber cane stripped of its tops and leaves. Testing was performed for pure fuels and for biomass co-firing with the coal at levels of 30% / 70% by mass. The testing results show that the combustion products were enriched in sodium relative to the fuel composition during all tests, and they were enriched in potassium for the biomass co-firing tests. Alkali metals were relevant because compounds containing these elements are more readily releasable into the combustion products than refractory components that remain in large particles such as silicon, aluminum, and titanium. The present application of LIBS reveals its potential to provide an abundant amount of real-time information, provide real-time field information on the deposition propensity of different fuels and the effects of different fuels at boiler operating conditions.

Chapter 3: Experimental Instrumentation and Setup

3.1 Experimental Setup Introduction

A LIBS system was modified at the Energy Research Company, Plainfield, NJ, to test the feasibility of the LIBS technology to measure biomass feedstock elemental composition of interest for slagging propensity determination. The same setup was also used to analyze coal samples, as part of the study. In this system, a high-power laser is focused onto the sample surface to produce plasma, light from the plasma is captured by a spectrometers and the characteristic spectra of each element can be identified, allowing concentrations of elements in the sample to be measured. This technique could be applied for biomass co-firing power plants at the feedstock stream with further research. In this way, it will be possible to monitor coal-biomass blends composition in real-time.

A general layout showing the system components and the connections is shown as Figure 3.1.

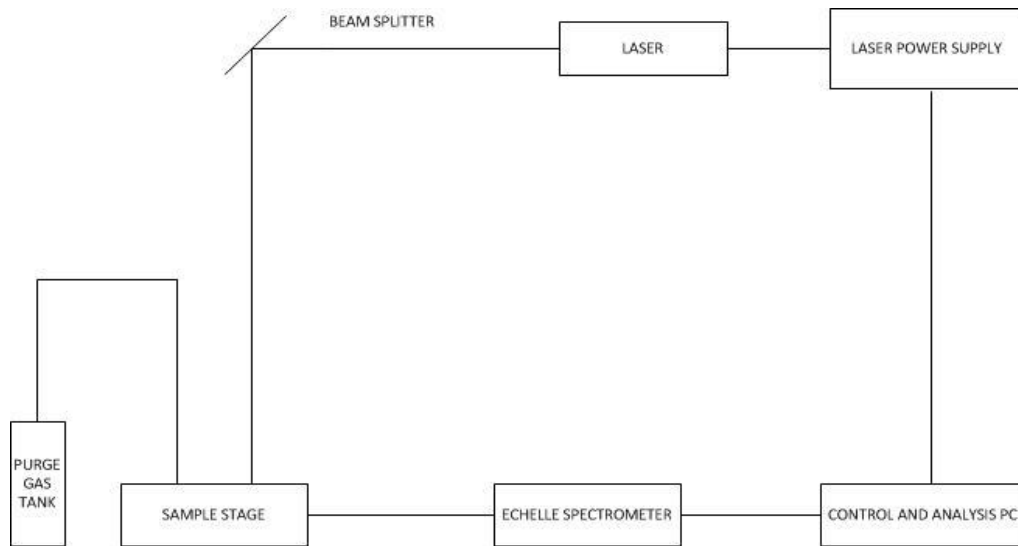

Figure 3.1: LIBS System General Layout

The LIBS system experimental setup consists of a sample stage, a tank for pumping protecting purge gas, an excitation Nd: YAG (neodymium-doped yttrium

aluminum garnet, Nd: $Y_3Al_5O_{12}$) laser, an optical spectrometer, and a computer with the system control software.

The laser applied in the LIBS system was an actively Q-switched Nd: YAG laser, a Quantel (USA) laser model CFR-400, which produces near infrared (IR) laser pulses, at a repetition rate of 10 HZ. The near IR pulses were directed down into the sample stage by 1064 nm laser mirrors. A lens directs the laser pulses onto the surface of the sample to create the LIBS spark. The Q-Switch Nd: YAG laser with pulse energies of approximately 300 mJ at 1064 nm was used to ablate and vaporize sample material and to induce the plasma at the time of the Q-switch trigger. The Echelle spectrometer controls the triggering of a flash lamp and the Q-switch. The time from the flash lamp trigger to the Q-switch trigger sets the laser power. An Echelle spectrometer (ESA-3000 LLA, Germany) was used to collect the spectra data for the analysis of elements in the samples. This spectrometer contains an Echelle type grating which allows for high resolution spectra to be collected over a broad wavelength range of 200 to 780 nm.

Figure 3.2 shows a photograph of the assembled LIBS system for experimentation. The laser head was located in a protective enclosure. Configuration of the system optics was done to allow for greater depth-of-field.

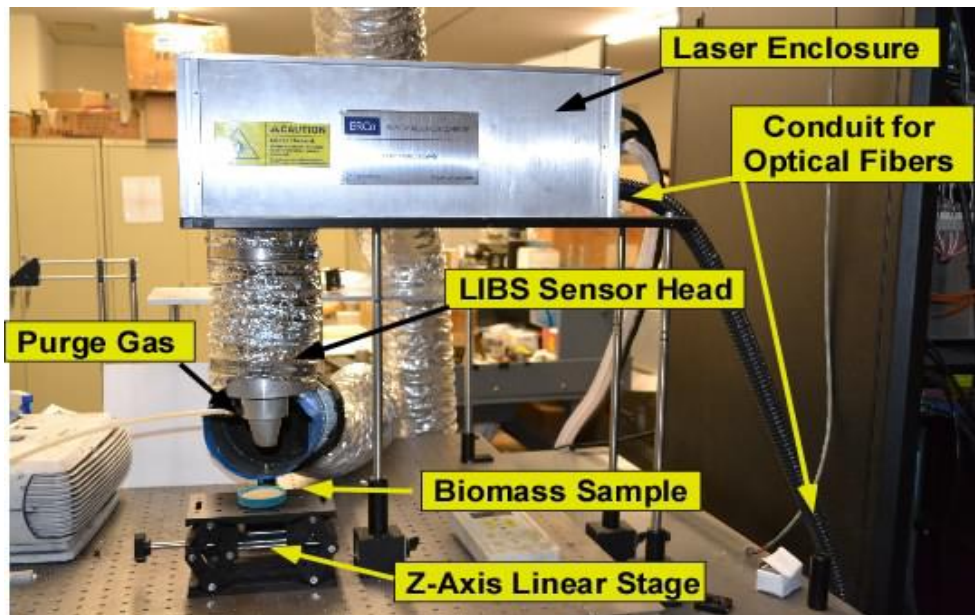

Figure 3.2: Photograph of LIBS Analyzer Installed in ERCo's Laboratory

3.2 Experimental Sample Preparation

The biomass samples were selected to cover a broad range of feedstock fired in the US and with a large enough range of properties pertinent to the characterization to be carried out with the LIBS technology. Three groups of biomass samples were targeted. Those groups correspond to biomass residues, dedicated energy crops, and woody biomass. The biomass materials were supplied by MESA Engineering & Processing, Inc. of Auburn, NY, in 5 lb bags, with the corresponding as-received inherent moisture. Samples from each of the following materials were used: biomass residues – corn stover, rice hulls, and wheat straw; energy crops – switch grass, *Arundo Donax*, and sugar cane bagasse, woody biomass – forest residue, willow trees, sawdust, land clearing and torrefied wood, coals (Central Appalachia (CAPP) and Illinois basin (ILB)). Additionally, blends of CAPP with corn stover, switch grass, and willow trees were also prepared.

Samples of materials were sent to an analytical laboratory for standardized ASTM testing for ultimate analysis, heating value, ash mineral analysis, and fusion temperatures. The fusion temperature analyses were performed under a reducing environment, since this atmosphere provides the lowest fusion temperature results. Lower fusion temperature analysis provides a more conservative approach to slagging potential prediction. Table 3.1 includes the laboratory analysis results for all the materials used in this project. As it can be seen from Table 3.1, due to cost, the samples of coal/biomass blends were not analyzed for coal and ash elemental concentration, and since that the major objective of the project was to determine the ability of LIBS to predict fusion temperature, as a surrogate to infer slagging potential. The blend ratio used for the biomass/coal blends were: 26% corn stover/74% CAPP, 24% switch grass/76% CAPP, and 23.4% willow trees/76.6% CAPP. These ratios correspond to 20% heat proportion, based on their individual calorific values.

Table 3.1: Material Sample Analysis

No.	Sample	Fusion Temp, G&C [deg. F]				wt. %		wt. %, dry basis				BTU/lb, dry basis	Ash Composition, wt. %										
		IT	ST	HT	FT	Total Moisture	As Detd. Moisture	Carbon	Hydrogen	Nitrogen	Sulfur	Heating Value	SiO2	Al2O3	TiO2	Fe2O3	CaO	MgO	Na2O	K2O	P2O5	SO3	MnO2
1	RICE HULLS	>2800	>2800	>2800	>2800	8.98	6.33	38.53	4.89	0.46	0.10	6623	97.54	0.05	0.02	0.16	0.53	0.38	0.03	1.47	0.77	0.26	0.14
2	SWITCHGRASS	1710	1916	2084	2219	9.30	6.36	47.48	5.91	0.51	0.11	8092	55.27	0.51	0.05	0.60	9.42	6.07	1.13	17.42	7.24	4.63	0.41
3	WHEAT STRAW	1600	1691	1974	2150	8.80	6.24	45.85	5.78	0.43	0.13	7894	48.32	0.31	0.05	0.40	8.03	3.51	1.22	24.64	8.31	5.82	0.14
4	WILLOW TREES	>2800	>2800	>2800	>2800	9.38	6.69	49.12	5.93	0.41	0.08	8326	4.91	1.49	0.33	1.85	52.17	3.96	0.72	7.51	9.70	3.49	1.16
5	LAND CLEARING	2747	2749	2752	2754	13.22	5.86	49.90	6.00	0.01	0.02	8390	4.58	1.16	0.09	0.89	47.15	10.91	0.73	8.34	7.48	7.34	10.72
6	SAWDUST	>2800	>2800	>2800	>2800	16.04	6.44	49.34	6.03	<0.01	0.04	8211	4.05	1.15	0.12	0.78	47.25	11.17	0.32	9.36	6.04	4.14	12.86
7	CORN STOVER	2213	2398	2627	>2800	9.19	4.97	42.37	5.15	0.49	0.07	7214	66.57	8.11	0.39	3.06	5.09	3.10	1.17	6.90	1.91	1.69	0.23
8	FOREST RESIDUE	2620	2681	2701	2731	17.63	7.80	50.21	5.98	0.15	0.03	8514	14.55	3.63	0.38	3.72	31.83	9.28	1.79	15.53	11.75	5.59	0.22
9	ARUNDO DONAX	2251	2298	2364	2447	9.86		44.74	5.81	0.59	0.39	10406	22.30	1.60	0.24	1.10	25.03	9.78	1.72	21.20	10.73	2.35	0.13
10	CANE BAGASSE	1889	1958	2070	2177	8.04		48.66	6.08	0.37	0.29	7388	44.92	2.91	0.21	2.84	16.42	5.88	1.03	16.63	3.95	4.25	0.19
11	TORREFIED WOOD	2001	2047	2221	2380	4.44	3.24	57.45	5.25	0.18	0.08	9825	42.18	11.43	0.66	4.96	23.95	4.19	2.68	5.88	1.69	3.18	0.21
12	CENTRAL APPALACHIAN COAL	2519	2574	2664	2760	11.73	3.18	70.74	4.79	1.22	1.25	12711	55.12	26.65	1.14	8.56	1.79	1.00	0.37	2.77	0.15	1.34	
13	ILLINOIS BASIN COAL	2027	2114	2364	2599	11.78	4.80	72.50	5.08	1.41	2.73	13082	50.60	19.67	0.88	17.00	4.24	0.95	0.88	2.36	0.28	4.16	
14	CAPP with Corn Stover	2371	2415	2481	2590																		
15	CAPP with Switchgrass	2278	2336	2399	2496																		
16	CAPP with Willow Trees	2456	2505	2583	2633																		

3.3 Measurement Procedures

An optimization of the LIBS system optical settings and operation was carried out on each of the biomass and coal samples containing detectable quantities of all elements of interest, before LIBS data were collected from all material samples. A number of laser shots, as determined from preliminary testing, were collected and averaged for each measurement. Each material and blends was analyzed to evaluate the measurement consistency and to provide a robust data set for data processing using the artificial intelligence tools. The testing cycle per sample consisted of moving the sample container on the Z-axis linear stage (see Figure 3.2) - for fresh sample material to be sparked, firing the LIBS system, and collecting the resulting spectrum by the spectrometer.

Chapter 4: Laboratory Experimental Results

Before using advanced data processing techniques to develop correlation models for high-order feedstock properties, for example, to predict ash fusion temperature, LIBS calibration curves were derived for all of the elements of interest. Calibration curves help provide information on the sensitivity, fidelity and quality of the spectral data in relation to the actual material samples. Calibration of LIBS data for accurate determination of elemental composition of solid samples is typically performed by comparing “like with like.” This comparison consists of matching up LIBS intensity measurement-derived concentration of individual elements with the concentration of oxides of the same element provided from standardized laboratory analysis. Calibration is the most difficult issue in LIBS data processing, especially for field measurements. In addition to the variables related to emission spectra, several other variables affect the intensity of the LIBS signal. These include the fluctuation of incident laser energy; the size and density of particles and associated sample matrix; the location of the focus point; and the surface feature and history of ablation by laser shots.

Calibration curves, constructed over the measured elemental concentration range (including all of the biomass and coal samples) for selected elements of interest, are shown in Figures 4.1 to 4.6. These curves were generated by plotting normalized LIBS intensity ratios versus the corresponding molar ratio estimated from the results from the standardized chemical analyses. Both parameters used to plot the calibration curves of Figures 4.1 to 4.6 were normalized with respect to Si. This normalization was done to minimize the impact of the variability of the background emission level in each individual set of measurements. It should be noticed that the calibration curves establish a relationship between concentrations of oxide forms of elements, from calcinated samples of ash analyzed with the standard procedure, while the LIBS-determined data is obtained from ablation of a coal sample and the spectral produced by all the elemental components in the sample. The calibration curves led to results that trend well, considering the broad range of concentrations for each elemental ratio, and the range of biomass coals with dissimilar properties. Very little sign of spectral saturation was observed from the data, which may occur at high concentrations of a particular element,

due to the ability of the atoms to absorb the emitted energy. However, the level of accuracy obtained from the calibration curves does not seem to be acceptable for operation of a fuel monitoring system for application at a power generation plant that fires a broad range of fuel feedstock. Different correlating functions are included in those figures to show the goodness of the correlation, in terms of the R-square of the correlations. The obtained R-squares of the correlations range from 0.71 for K to 0.96 for Al.

Table 4.1: S/B and S/N for Selected Atomic Emission Lines from the Switchgrass Sample

Element	Average Signal (S)	Average Background (B)	σ Background (N)	S/B	S/N
C	1322.63	131.50	26.35	10.06	50.19
Fe	1952.50	88.62	9.10	22.03	214.51
Mg	726.07	257.87	10.54	2.82	68.92
Mg	4957.04	254.64	30.16	19.47	164.34
Si	2854.05	183.95	17.00	15.52	167.84
Al	373.67	113.68	8.43	3.29	44.34
Al	897.85	113.68	8.43	7.90	106.53
Ti	535.71	139.65	13.89	3.84	38.56
Fe	1034.60	171.65	24.89	6.03	41.56
Ca	9518.56	154.16	50.27	61.74	189.34
Al	932.54	154.16	50.27	6.05	18.55
Al	1754.00	154.16	50.27	11.38	34.89
Ca	12004.81	154.16	50.27	77.87	238.80
Ca	5195.11	214.76	18.56	24.19	279.96
Na	606.00	55.04	8.33	11.01	72.78
Na	423.82	55.04	8.33	7.70	50.90

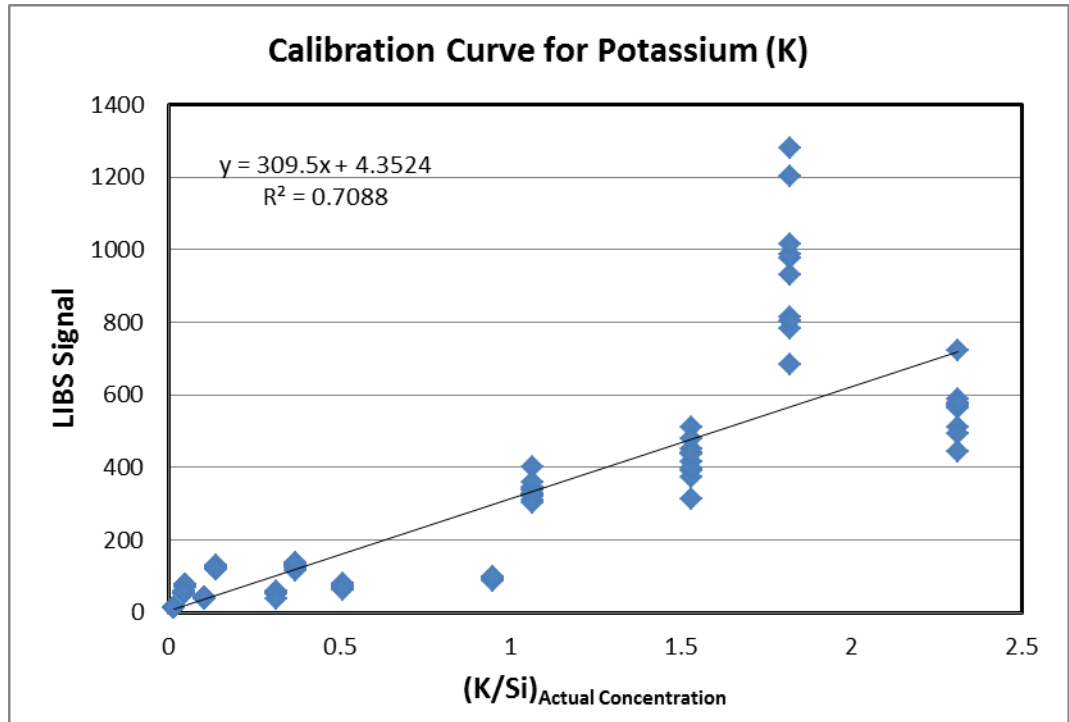

Figure 4.1: Calibration Plot for K (769.9 nm) Emission Line

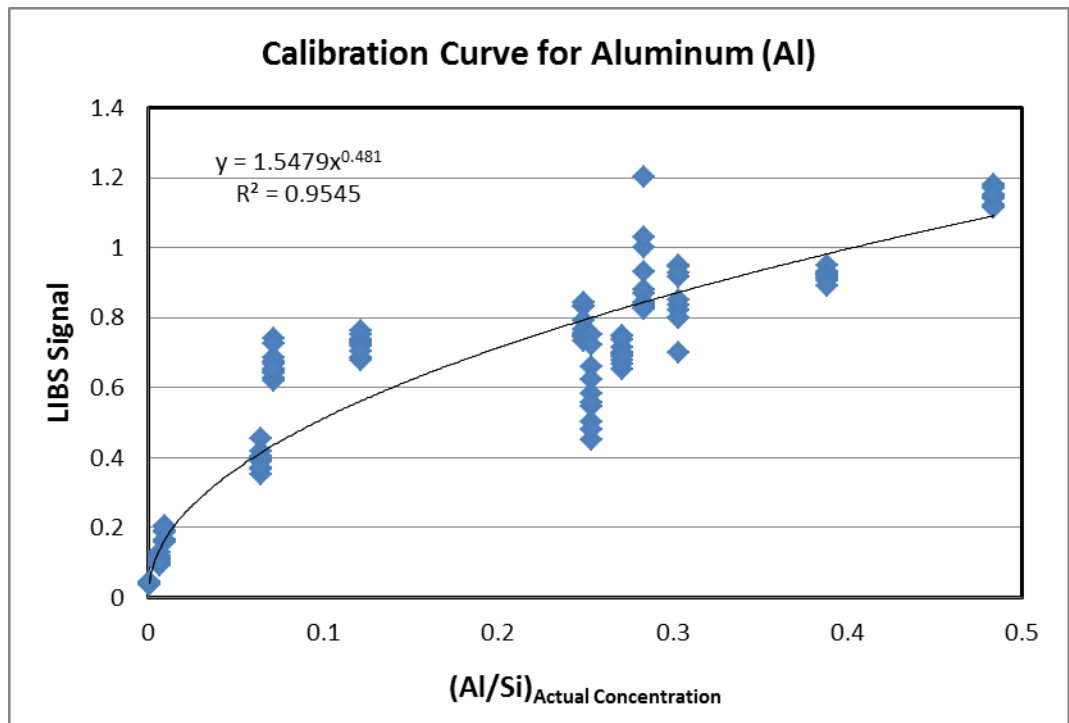

Figure 4.2: Calibration Plot for Al (309.3 nm) Emission Line

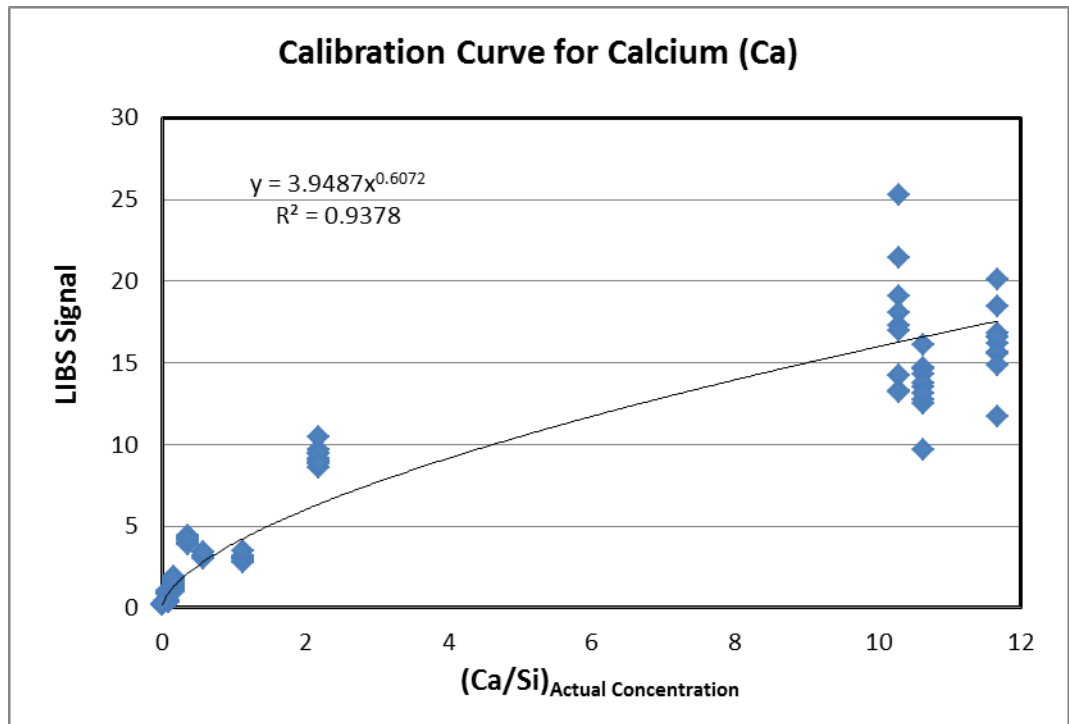

Figure 4.3: Calibration Plot for Ca (422.7 nm) Emission Line

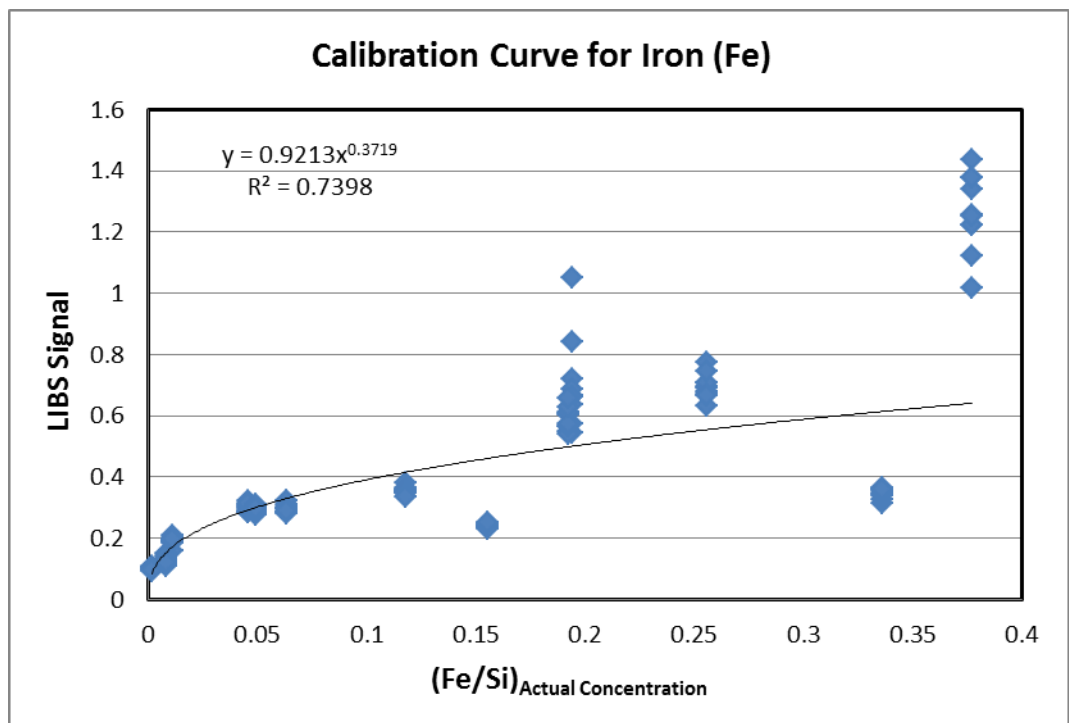

Figure 4.4: Calibration Plot for Fe (259.9 nm) Emission Line

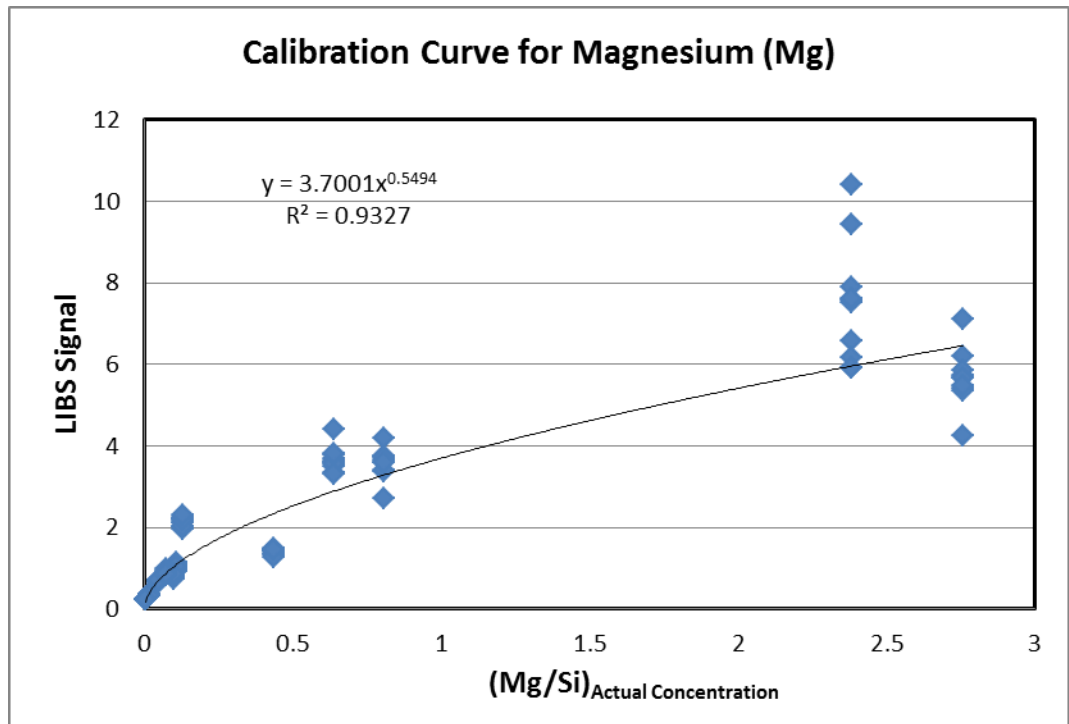

Figure 4.5: Calibration Plots for Mg (285.2 nm) Emission Line

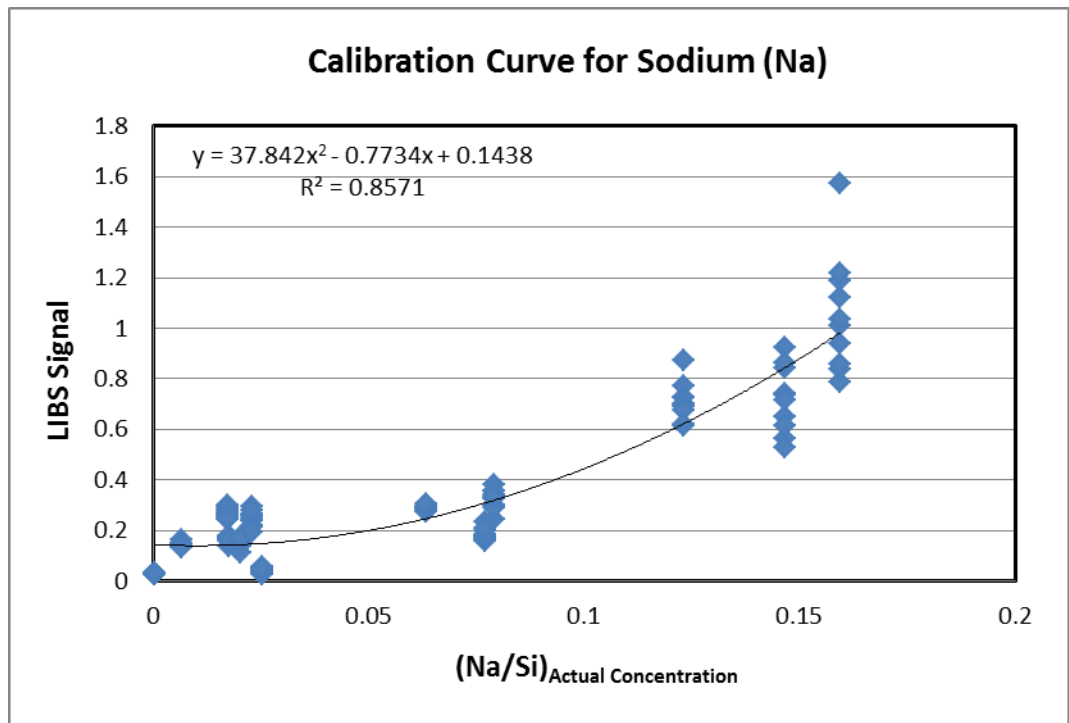

Figure 4.6: Calibration Plots for Na (589.0 nm) Emission Line

Chapter 5: Results

This study explored using advanced data processing techniques to develop correlation models that utilize LIBS-based biomass and coal elemental information to predict slagging potential information, which would be used by operators in biomass co-firing power generation plants. An approach was developed and proven more accurate in correlating raw LIBS spectral for elemental composition than the calibration curve approach described in Chapter 4. The approach was also been satisfactory in predicting higher-order coal properties which include ash fusion temperature and heating value.

The results for prediction of the metal oxides are shown in Figures 28 to 35 for the models developed for the particular biomass feedstock groups. The appropriateness of the fit was evaluated using the root-mean square error, as defined by:

$$RMSE = \sqrt{\frac{\sum_{t=1}^n (y_t - \hat{y}_t)^2}{n}}$$

where \hat{y}_t is the predicted expected value for time t, of a regression's dependent variable y, for n different prediction. The RMSE's in Figures 28 to 35 show good correlation and acceptable learning efficiency of the BP networks for sample composition. The RMSE values (absolute errors) in those figures correspond to relative errors for Al₂O₃, CaO, Fe₂O₃, K₂O, MgO, Na₂O, SiO₂ and TiO₂, of 4.57, 4.31, 8.33, 1.61, 4.28, 5.25, 1.61 and 6.96%, respectively. The relative error for the generic model ranged from 8.55 up to 37.24% for all metal oxides, except titanium oxide, which had a relative measurement error as high as 54.57%.

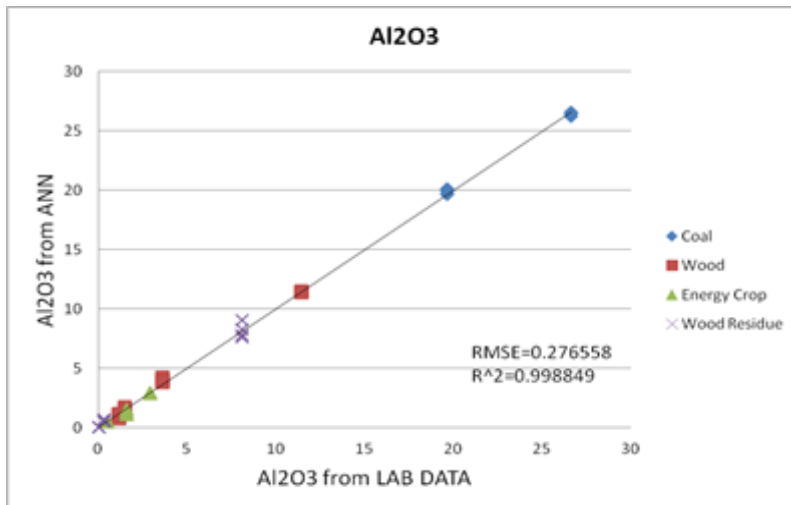

Figure 5.1: Results for Prediction of Al₂O₃

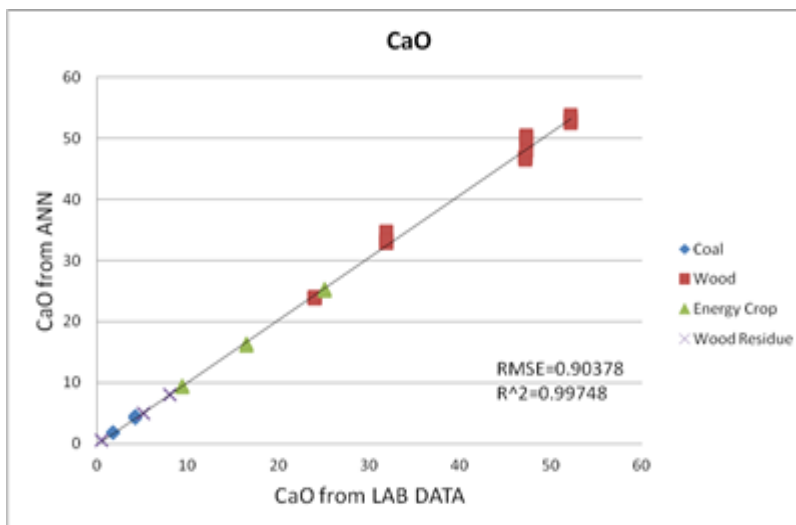

Figure 5.2: Results for Prediction of CaO

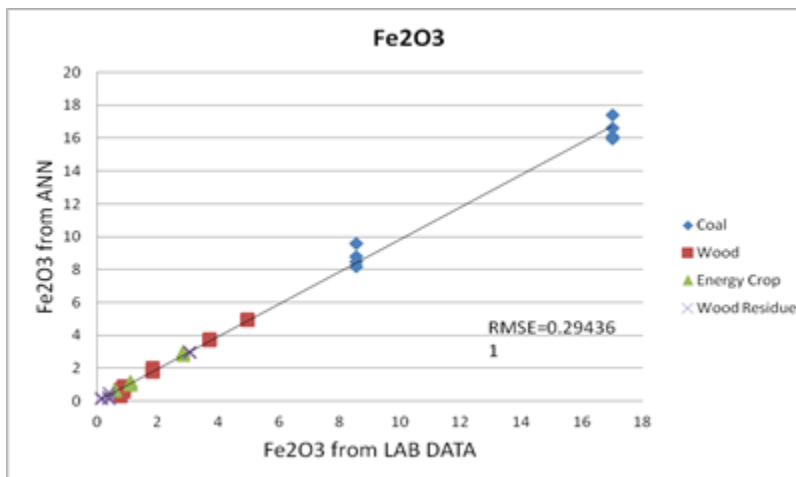

Figure 5.3: Results for Prediction of Fe₂O₃

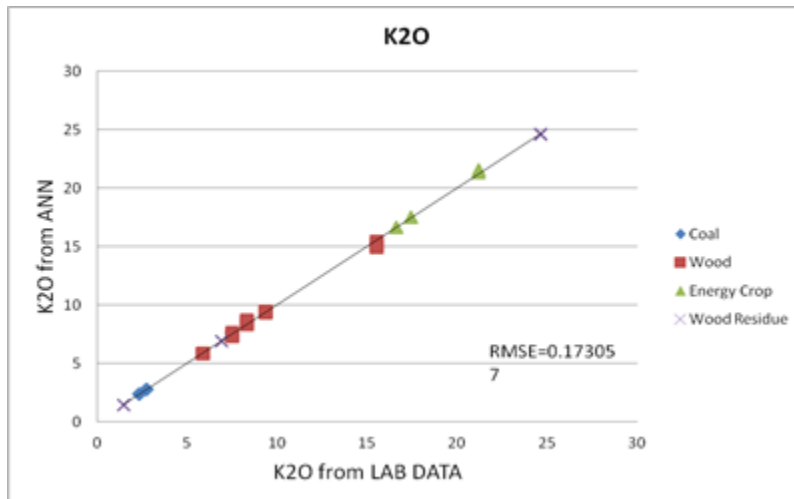

Figure 5.4: Results for Prediction of K₂O

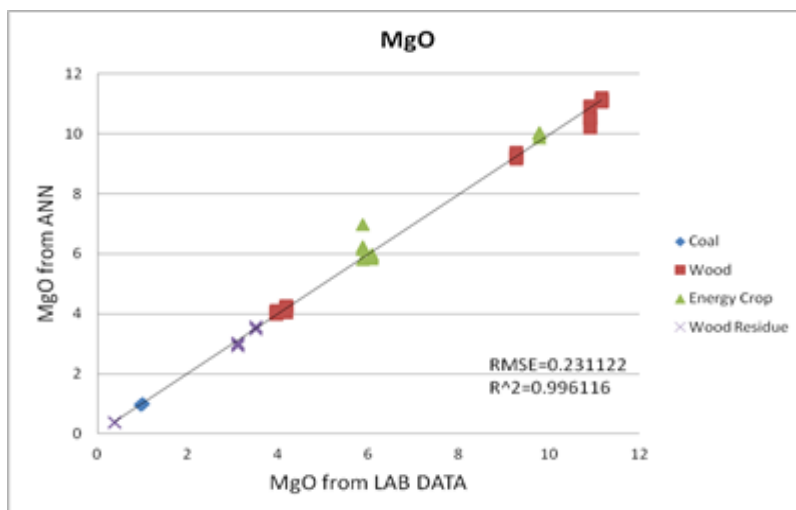

Figure 5.5: Results for Prediction of MgO

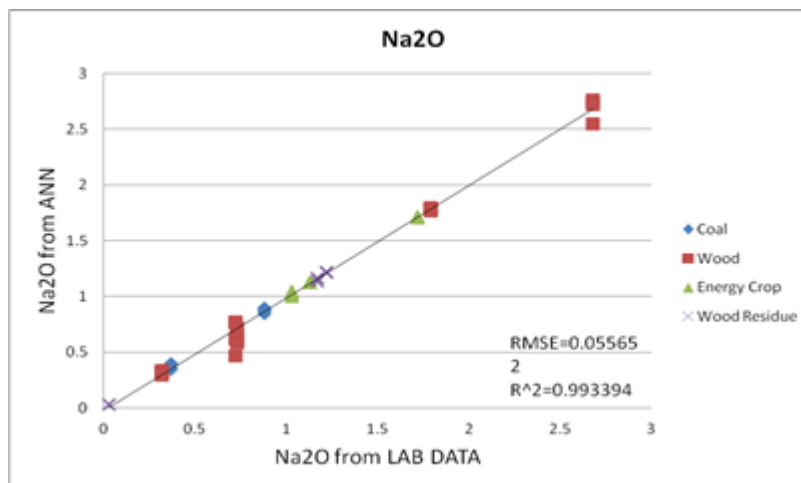

Figure 5.6: Results for Prediction of Na₂O

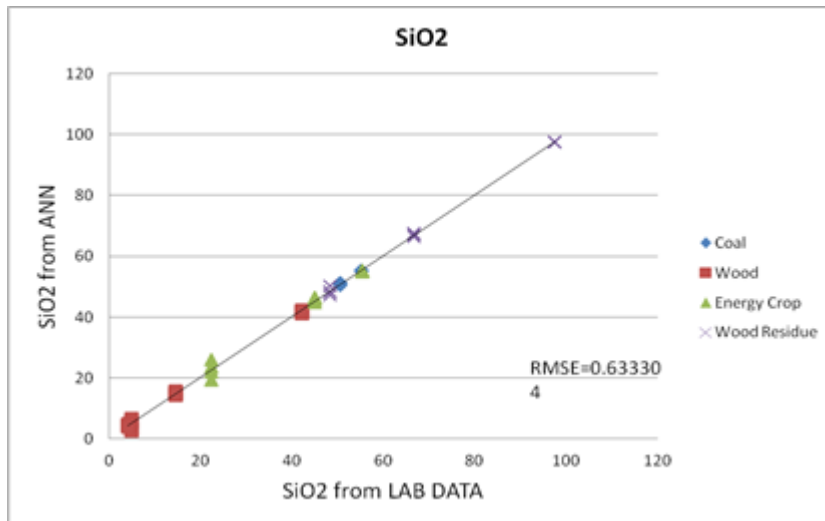

Figure 5.7: Results for Prediction of SiO₂

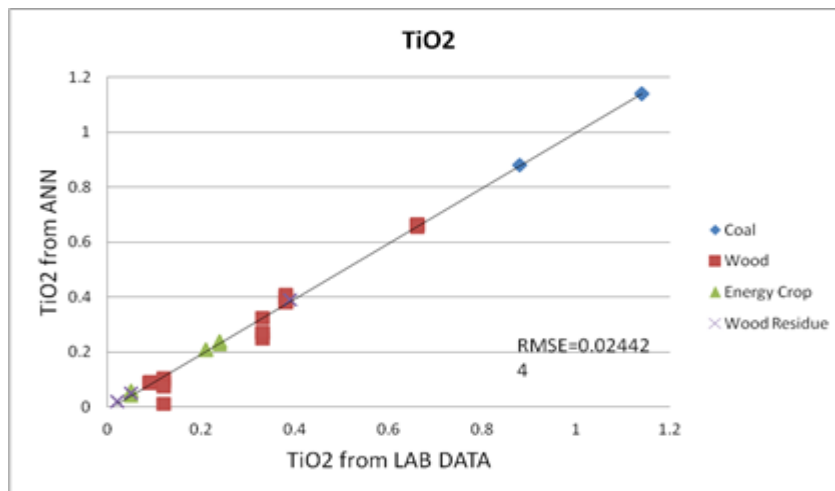

Figure 5.8: Results for Prediction of TiO₂

The results for heating value (dry basis) applicable to the entire range of biomass and coal feedstock used in this project are included in Figure 5.12. The prediction has a combined RMSE of ± 15.25 Btu/lb. Though these results are based on a single limited data set, these results indicate that there is a significant potential for monitoring heating value of coal and biomass feedstock using a concept based on the LIBS technique and advanced data processing.

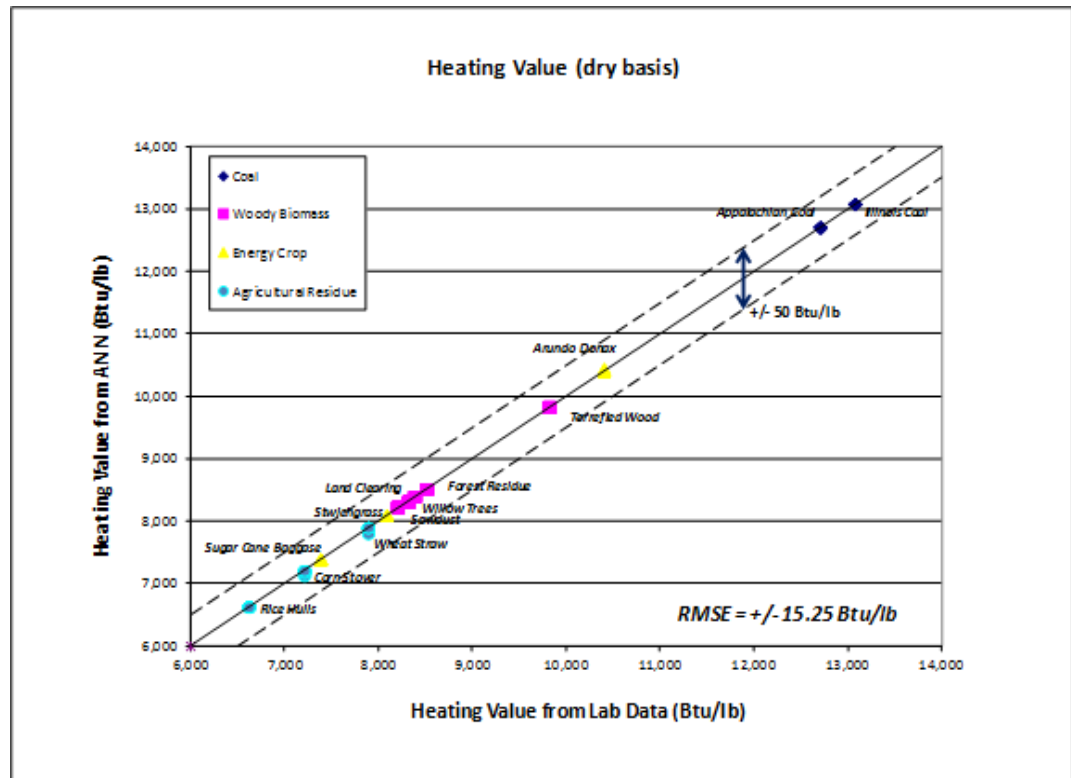

Figure 5.9: Prediction Results for Heating Value

Results for initial deformation fusion temperature are included in Figure 5.13. The results in Figure 5.13 show a RMSE for the temperature prediction of $\pm 33.34^{\circ}F$. This represents a relative accuracy of $\pm 1.4\%$, referred to the average fusion temperature for the entire range from $1,600^{\circ}F$ for wheat straw to at least $2,800^{\circ}F$ for rice hulls, sawdust and willow trees. The results for initial deformation temperature for each of the four biomass and coal groups, are improved to a combined RMSE of $\pm 15.24^{\circ}F$. The results for heating value and fusion temperature have associated higher accuracy than the results obtained for elemental composition of metal oxides.

The results in Figure 5.13 also include fusion temperature predictions of blends of coal and biomass. The intention was to explore the feasibility of the LIBS/Advanced Data Processing approach to predict blend properties of importance to a power producing facility that would co-fired coal with biomass. Three blends at a 20/80% biomass/coal ratio, by heat input (CAPP/corn stover, CAPP/switch grass, CAPP/willow tree) were used. The inputs values for the blends were estimated using weighted averages of each of

the elemental concentrations as detected by LIBS. The corresponding blend weight ratio for CAPP and corn stover, switch grass and willow tress was 26.0, 24.0 and 23.4%, respectively.

The results for the blends are included in Figure 5.13. The predictions for the CAPP/corn stover and CAPP/willow tress blends are within the specified error band ($\pm 100^\circ F$). However, the fusion temperature predictions for the CAP/switch grass are 17.2, 116.8 and 76.5 $^\circ F$, representing 0.7, 5.1 and 1.5%, respectively. This may be due to the impact some individual ash elements may have of the fusion temperatures. This is of great importance to operators of boilers that would like to anticipate the properties of the fuel blend when they co-fire coal and biomass and its relative impact of boiler operation, emissions and unit availability.

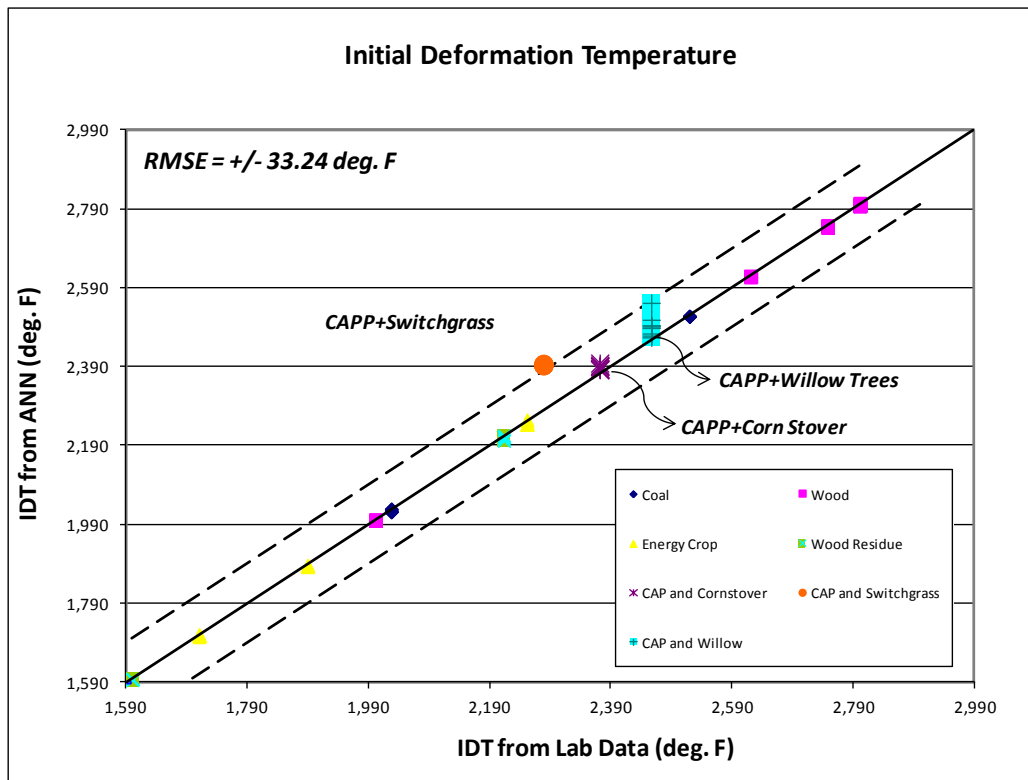

Figure 5.10: Prediction Results for Initial Deformation Fusion Temperature(IDT)

Chapter 6: Conclusions and Recommendations

In this study, the ability of laser-induced breakdown spectroscopy and advanced data processing to measure important parameters of biomass and also biomass/coal blends has been successfully demonstrated. This will more easily allow coal-fired electric generating power plants to supplement their coal use with biomass; thus, substantially reducing greenhouse gases. The testing covered a number of biomass residues, energy crops, woody biomass, coals, and blends of coal and biomass. Heating value, ash fusion temperature, and a number of mineral oxides were successfully measured/predicted. It was shown that these parameters can be accurately monitored in a future real-time LIBS installation, allowing a boiler operator to optimize the plant efficiency and minimize expensive slagging and fouling problems.

It is recommend that the technology be taken to the next level and be tested at a power plant that co-fires biomass and coal.

References

1. Abel, Tortosa-Masi á Ahnert Falk, Spliethoff Harmut, Loux Claude, and Hein Klaus. "Slagging and Fouling in Biomass Co-combustion." *Thermal Science* 9.3 (2005): 85-98. Print.
2. Robinson, A. L., J. S. Rhodes, and D. W. Keith. "Assessment of Potential Carbon Dioxide Reductions Due to Biomass–Coal Cofiring in the United States." *Environmental Science & Technology* 37.22 (2003): 5081-089. Print.
3. Baxter, L. "Biomass-coal Co-combustion: Opportunity for Affordable Renewable Energy." *Fuel* 84.10 (2005): 1295-302. Print.
4. Robinson, Allen L., Helle Junker, and Larry L. Baxter. "Pilot-Scale Investigation of the Influence of Coal–Biomass Cofiring on Ash Deposition." *Energy & Fuels* 16.2 (2002): 343-55. Print.
5. Yin, Chungeng, Zhongyang Luo, Mingjiang Ni, and Kefa Cen. "Predicting Coal Ash Fusion Temperature with a Back-propagation Neural Network Model." *Fuel* 77.15 (1998): 1777-782. Print.
6. Seggiani, Maurizia, and Gabriele Pannocchia. "Prediction of Coal Ash Thermal Properties Using Partial Least-Squares Regression." *Industrial & Engineering Chemistry Research* 42.20 (2003): 4919-926. Print.
7. Zhao, Bingtao, Zhongxiao Zhang, and Xiaojiang Wu. "Prediction of Coal Ash Fusion Temperature by Least-Squares Support Vector Machine Model." *Energy & Fuels* 24.5 (2010): 3066-071. Print.
8. Blevins, Linda G., Christopher R. Shaddix, Shane M. Sickafoose, and Peter M. Walsh. "Laser-Induced Breakdown Spectroscopy at High Temperatures in Industrial Boilers and Furnaces." *Applied Optics* 42.30 (2003): 6107. Print.
9. Yin, Wangbao, Lei Zhang, Lei Dong, Weiguang Ma, and Suotang Jia. "Design of a Laser-Induced Breakdown Spectroscopy System for On-Line Quality Analysis of Pulverized Coal in Power Plants." *Applied Spectroscopy* 63.8 (2009): 865-72. Print.
10. Hatt, Rod. "Influence of Coal Quality and Boiler Operating Conditions on Slagging of Utility Boilers." (n.d.): n. pag. Print.
11. Hatt, R. "Fireside Deposits in Coal-fired Utility Boilers." *Progress in Energy and Combustion Science* 16.4 (1990): 235-41. Print.
12. Pronobis, M. "The Influence of Biomass Co-combustion on Boiler Fouling and Efficiency." *Fuel* 85.4 (2006): 474-80. Print.
13. Stam, A. F. "Review of Models and Tools for Slagging and Fouling Prediction for Biomass Co-combustion." (n.d.): n. pag. Print.

14. Attig, C., and A. Duzzy. "Coal Ash Depositional Studies and Application to Boiler Design." *American Power Conference, Chicago, IL., Illinois Institute of Technology*(1969): n. pag. Print.
15. Winegartner, E. C. *Coal Fouling and Slagging Parameters*. [New York]: ASME, 1974. Print.
16. Niu, Yanqing, Hongzhang Tan, Xuebin Wang, Zhengning Liu, Haiyu Liu, Yang Liu, and Tongmo Xu. "Study on Fusion Characteristics of Biomass Ash." *Bioresource Technology* 101 (2010): 9373-9381. Print.
17. Li, Q.H, Y.G Zhang, and A.H Meng. "Study on Ash Fusion Temperature Using Original and Simulated Biomass Ashes." *Fuel Processing Technology* 107 (2013): 107-112. Print.
18. Seggiani, M. "Empirical Correlations of the Ash Fusion Temperatures and Temperature of Critical Viscosity for Coal and Biomass Ashes." *Fuel and Energy Abstracts* 41.6 (2000): 367. Print.
19. Mastalerz, Maria, A. Drobniak, John Rupp, and Nelson Shaffer. "Availability of the Reserves, Physical and Chemical Properties of the Coal, and the Present and Potential Uses." (n.d.): n. pag. Print.
20. Cremers, David A., and Leon J. Radziemski. *Handbook of Laser Induced Breakdown Spectroscopy*. Chichester: Wiley, 2013. Print.
21. Sneddon, Joseph, and Yong Lee. "Application of Laser-induced Breakdown Spectrometry in Urban Health." *Microchemical* 67.1-3 (2000): 201-05. Print.
22. Yin, Wangbao, Lei Zhang, Lei Dong, Weiguang Ma, and Suotang Jia. "Design of a Laser-Induced Breakdown Spectroscopy System for On-Line Quality Analysis of Pulverized Coal in Power Plants." *Applied Spectroscopy* 63.8 (2009): 865-72. Print.
23. Ottesen, David K., L. L. Baxter, L. J. Radziemski, and J. F. Burrows. "Laser Spark Emission Spectroscopy for In-situ, Real-time Monitoring of Pulverized Coal Particle Composition." *Energy & Fuels* 5.2 (1991): 304-12. Print.
24. Chadwick, Bruce L., and Doug Body. "Development and Commercial Evaluation of Laser-Induced Breakdown Spectroscopy Chemical Analysis Technology in the Coal Power Generation Industry." *Applied Spectroscopy* 56.1 (2002): 70-74. Print.
25. Stankova, Alice, Nicole Gilon, Lionel Dutruch, and Viktor Kanicky. "A Simple LIBS Method for Fast Quantitative Analysis of Fly Ashes." *Fuel* 89.11 (2010): 3468-474. Print.
26. Romero, Carlos E., Robert De Saro, Joseph Craparo, Arel Weisberg, Ricardo Moreno, and Zheng Yao. "Laser-Induced Breakdown Spectroscopy for Coal Characterization and Assessing Slagging Propensity." *Energy & Fuels* (2009): 091019142552047. Print.

27. Li, Jie, Jidong Lu, Zhaoxiang Lin, Shunsheng Gong, Chengli Xie, Liang Chang, Lifei Yang, and Pengyan Li. "Effects of Experimental Parameters on Elemental Analysis of Coal by Laser-induced Breakdown Spectroscopy." *Optics & Laser Technology* 41.8 (2009): 907-13. Print.
28. Blevins, Linda G., Christopher R. Shaddix, Shane M. Sickafoose, and Peter M. Walsh. "Laser-Induced Breakdown Spectroscopy at High Temperatures in Industrial Boilers and Furnaces." *Applied Optics* 42.30 (2003): 6107. Print.
29. Jenkins, Bryan, Robert Williams, Scott Turn, Lee Jakeway, and Linda Blevins. "Closed-loop Biomass Co-firing in a Laboratory Reactor and in a Full-scale Boiler." (n.d.): n. pag. Print.

Vita

Tong Zhu

Birth Date: November 28th, 1988

Birth Place: Anqing, China

Name of Parents: Xuehua Zhu (Father), Wenxia Li (Mother)

Institutes Attended and Degrees:

Lehigh University, Bethlehem, USA

Master of Science in Mechanical Engineering (to be awarded) 09/2013

Xi'an Jiaotong University, Xi'an, China

Bachelor of Science in Energy Power System and Automation 06/2010

Research Area: Energy Research in Mechanical Engineering

Professional Experiences:

Research Assistant 04/2011-07/2013
Energy Research Center, Lehigh University Bethlehem, Pennsylvania
Laboratory and field research on the biomass co-firing technology and other energy-related topics.