

1984

Earthquake resistance of high-rise systems. Classification of tall building systems.

Daniel W. Falconer

Lynn S. Beedle

Follow this and additional works at: <http://preserve.lehigh.edu/engr-civil-environmental-fritz-lab-reports>

Recommended Citation

Falconer, Daniel W. and Beedle, Lynn S., "Earthquake resistance of high-rise systems. Classification of tall building systems." (1984). *Fritz Laboratory Reports*. Paper 2223.
<http://preserve.lehigh.edu/engr-civil-environmental-fritz-lab-reports/2223>

This Technical Report is brought to you for free and open access by the Civil and Environmental Engineering at Lehigh Preserve. It has been accepted for inclusion in Fritz Laboratory Reports by an authorized administrator of Lehigh Preserve. For more information, please contact preserve@lehigh.edu.

EARTHQUAKE RESISTANCE OF HIGH-RISE SYSTEMS

CLASSIFICATION OF TALL BUILDING SYSTEMS

by

Daniel W. Falconer

Lynn S. Beedle

This work has been carried out as part of
an investigation sponsored by the National
Science Foundation, Grant No. PFR 8105306,
and Grand No. CEE 8105306

Department of Civil Engineering

Fritz Engineering Laboratory
Lehigh University
Bethlehem, Pennsylvania 18015

20 May 1984

Fritz Engineering Laboratory Report 442.3

Table of Contents

ABSTRACT	1
1. INTRODUCTION	2
2. NEED FOR A CLASSIFICATION SCHEME	3
3. TALL BUILDINGS AND THEIR SYSTEMS	5
4. STRUCTURAL SYSTEMS	8
4.1 Alternative Classification Schemes	9
4.2 Proposed Classification Scheme	14
5. STRUCTURAL MATERIAL SYSTEMS	19
6. MECHANICAL SYSTEMS	20
6.1 Heating, Ventilation, and Air Conditioning	20
6.2 Plumbing Systems	25
7. VERTICAL TRANSPORTATION	29
8. ARCHITECTURAL SYSTEMS	31
8.1 Cladding	31
8.2 Partitions and Walls	32
9. UTILIZATION OF CLASSIFICATION SCHEMES	34
10. FURTHER STUDIES	35
11. SUMMARY	36
ACKNOWLEDGEMENTS	37
GLOSSARY	38
TABLES	44
FIGURES	71
REFERENCES/BIBLIOGRAPHY	93

ABSTRACT

As the number of different high-rise structures in existence increases every year, so also is there an increase in the possibility of damage due to earthquake, wind, or other hazards. In the event of such damage it is important to be able to correlate damage intensity with the particular tall building system used. A classification scheme for these systems is required, and this report presents such a codification.

The systems selected for study include the structural systems, the structural materials, selected mechanical systems, the vertical transportation systems, and selected architectural systems. Greatest attention is given to the structural systems.

Of the various alternatives, a framing-oriented scheme is chosen as a means of classifying structural systems. The fundamental systems within it are bearing wall, core, tube, and frame, together with the appropriate mixtures of these systems. A numerical designation system provides opportunity to catalog the specific details of the system in a computer data base. This in turn opens the way to the study of possible correlation of any observed damage with the system or subsystem.

1. INTRODUCTION

The object of this report is to develop a classification scheme for some of the more important tall building systems. The systems chosen for classification are the structural system, structural materials and selected mechanical and architectural systems. The major emphasis is placed upon the structural system.

Tall buildings are highly sophisticated engineering projects. Due to the complexity of the structures, the most advanced engineering design techniques are needed in tall buildings. To develop these techniques, new and existing research and empirical studies need to be documented in a usable and accessible form.

By definition, a classification system imposes order on a large body of information. If there were only a few tall buildings in the world, codification schemes would not be needed. However, tall buildings exist all over the world, and their numbers are increasing every year.

In order to design better tall buildings, information must be collected on the performance of existing tall buildings. The classification helps create a structured order in which to store information collected about high-rise buildings.

In the past, it was not uncommon to totally separate the structural engineering from the mechanical and architectural aspects of tall building planning and design. Today, however, the tall building is more commonly designed from a "team" approach, with interaction between the key professionals. In keeping with this philosophy, the tall building classification systems are extended beyond the structural classification to encompass selected mechanical and architectural systems.

2. NEED FOR A CLASSIFICATION SCHEME

It is important to realize that a significant amount of construction will be required in the next 50 years -- enough to service twice the present world population according to some conservative estimates (Keyfitz) -- and a large percentage of that will be in the high-rise environment. Since in both present and future buildings the design ultimate load could, in fact, be attained, it is important to know how the various systems perform and which ones perform the best.

In the following chapters, fundamentally representative classification schemes for tall building systems will be presented. Why are they needed? Towards what use can these schemes be applied?

The answers to these questions go back to the need to determine the extent to which present analytical approaches adequately represent behavior in actual buildings under normal and extreme loads (such as earthquakes, strong winds, and other hazards) and under service situations and use. The basic question is this: is it possible to establish a correlation between the particular systems or subsystems used in tall buildings and the way in which these systems respond under extreme and service loads?

If the response can be predicted and confirmed in an appropriate sample of the large number of tall buildings throughout the world -- in other words if a correlation can be established between a particular system or subsystem and its behavior in specific applications -- then this information will be of fundamental importance in new designs. It will be of equal importance in assessing the probable performance of existing buildings that have not yet encountered such loading and service conditions. Necessary steps for correction of any major shortcomings can then be recommended. In case a building is to be renovated for other reasons, those with less-favorable systems can receive the appropriate attention.

This type of research will require as complete an identification as possible of the tall buildings around the world and the details of the systems that are used therein. It will require documentation of the performance of these systems. To achieve this, a comprehensive worldwide survey must be made of tall buildings and their systems. A logical and consistent format is essential if meaningful results are to be obtained, and this study of tall building classification aims to provide such order and

structure.

Another major potential benefit of acquiring a large body of information about tall buildings, especially in earthquake-prone regions, is that a real-life laboratory is created. When an earthquake strikes, there would be a wide range of easily accessible information available to investigators and researchers. The various tall building systems (structural, mechanical, etc.) could be compared as to their ability to function during and after an earthquake. Interaction between different tall building systems could be studied to determine the combinations of systems that function well together and those that do not (Sun, 1979). Responsible authorities and private assessors could more quickly evaluate monetary and property losses by having prior knowledge of the damaged buildings. Projections could be made of future possible losses. It could assist damage evaluation teams as they prepare for site visits, and an inventory that includes the professionals involved would facilitate procurement of needed supplementary information.

3. TALL BUILDINGS AND THEIR SYSTEMS

The term, "high-rise", is defined in Webster's dictionary as a "building of many stories". This serves to illustrate the term's subjectivity. Do any clear and precise definitions exist, and on what basis are they founded?

Many local fire codes in the USA base their definition of a tall building on the height to which their fire ladders will reach from the street. Depending on the city, this could range from 6 to 10 stories in the USA. Some plumbing engineers would argue that only when a building has more than 25 stories do design concepts require modification for plumbing systems. Other professionals argue from other perspectives.

The definition of a tall building was one of the first topics to come under discussion by the Council on Tall Buildings and Urban Habitat, an international group sponsored by engineering, architectural, and planning professionals, that was established to study and report on all aspects of the planning, design, construction, and operation of tall buildings. As described in its Monograph (Council, 1978-1981), it is not so much a matter of a limiting height or number of stories. Rather, "The important criterion is whether or not the design is influenced by some aspect of tallness." A suggested definition, then, might be "a building in which tallness strongly influences planning, design and use"; or "a building whose height creates different conditions in the design, construction, and use than those that exist in common buildings of a certain region and period". For purposes of standardization, in connection with its survey of tall building characteristics, the Council collects information on buildings that are nine stories or more in height.

Four different categories of building systems have been identified (Beedle, 1980). These are Loading Systems, Physical Systems, Functional Systems, and Building Implementation Systems. They are shown in detail in Fig. 1. Under the "Physical Systems" heading are such items as foundation systems, structural framework, mechanical and service systems, and electrical systems. The building systems this report will classify are the structural, material, mechanical, vertical transportation, and architectural systems.

In general, the structural system of a building is a three-dimensional complex assemblage of interconnected structural

elements (Council, Committee 3, 1980). The primary function of the structural system is to effectively and safely carry all the loads which act upon the building, and to resist sway by providing adequate stiffness. The structural system physically supports the entire building, and with it, all the other various building systems.

The mechanical systems studied in this report are the heating, ventilation and air conditioning (HVAC) system, and the plumbing systems. Among other needs, the HVAC system in a tall building must be responsive to environmental requirements, energy consumption, and smoke and fire management. The plumbing system must be able to meet the water demand of the high-rise (both supply and discharge) under all service and emergency conditions. The vertical transportation system must respond to the user promptly, since its function is that of a time and labor saving device. By gaining a few seconds for each passenger on every trip, effective elevator service can save valuable man-hours (Adler, 1970).

The architectural systems examined in this report are the partition system and the cladding (curtain wall) system. The function of partitions in a building is the separation of large space into smaller areas for privacy or safety. The function of the cladding (curtain wall) system is to regulate the passage of light, moisture, temperature transfer, dirt, and, of course, people through the building's "skin". It must also serve to provide acoustical control from outside noise and to assist in fire control (Council, Committee 2A, 1980).

The systems identified above were chosen because they generally meet the following criteria: during a natural disaster (earthquake, strong wind, fire) would the failure of these systems most likely lead to possible loss of life? The failure of even a part of the structural system is an obvious threat to anyone in a tall building at the time of a disaster, and usually leads to failure of the mechanical and architectural systems attached and supported at those points. The loss of the mechanical systems in a tall building may constitute a threat to life. The ventilation system is vital during a fire, because of the smoke that must be removed. Similarly, the plumbing system is also of great importance in fighting fire in tall buildings since it delivers water to the sprinklers and fire hoses. The failure of the vertical transportation system could trap people.

The failure of the cladding or partition systems can also constitute a hazard to life. The cladding system must be able to function during a strong wind to protect the occupants and contents

442.3

of the building. Its attachment to the framework must assure that it does not fragment during an earthquake or storm. In many tall buildings, the partition system is an integral part of the fire protection system by providing what is known as "compartmentalization" thus helping to prevent the spread of fire (Council, Committee 2B, 1980).

4. STRUCTURAL SYSTEMS

This chapter presents the different types of tall building structural systems, and the various methods of classifying them. It includes a summary of the previous work that has been done in this field.

The structural system of a building must resist both gravity and lateral loads due to such phenomena as wind and earthquakes. As the height of the building increases, the lateral loads begin to dominate the structural design. Figure 2 (Khan, 1974) schematically compares some frequently used steel and concrete structural systems on the basis of structural efficiency (as measured by weight per square foot of the system versus height of the building).

Bearing wall structures could be used in high-rise buildings up to 20 stories. A tube structure is commonly employed in the tallest buildings built to date (1984).

Lateral loads due to wind and earthquake produce lateral accelerations. As people normally perceive these accelerations at much lower levels than the structural safety limit, stiffness rather than strength tends to become the dominant factor in buildings of great height.

Four over-all groupings of structural systems have been identified. These are the bearing wall system, the core system, the frame system, and the tube system. Each system has inherently different lateral load resistant properties and thus tends to be "efficient" over different height regions.

The bearing wall system due to the self weight of the structural components (solid concrete or masonry), usually becomes inefficient (cost of the structural system versus its height) above the 15-30 story range of height.

The concrete core system has the same disadvantage as the bearing wall system, namely self weight of solid concrete or masonry as a limiting factor.

The efficiency of the frame system depends upon the rigidity of the connections and the amount of bracing. Stiffening can be achieved through a solid core, shear walls or diagonal bracing. As

more bracing is incorporated into the spatial frame, the range of efficient height is increased. The upper limit is in the range of 60 stories.

The tube system can be thought of as a spatial frame with all the vertical elements positioned at the exterior. The range of height efficiency is influenced by the type and amount of bracing employed in the tube, but in general, a tube structure is considered the most efficient for the tallest buildings (60 stories and greater).

4.1 Alternative Classification Schemes

It is difficult to create a classification system that succeeds in isolating consistent criteria for tall building structural systems. This is due to the large number of possible variables such as the number of stories, building material, framing system, and load resistance properties. Tall buildings themselves are diverse in nature of usage, location, geometric shape and architectural design. Thus there are difficulties in arriving at a comprehensive method for classifying them.

The literature suggests that there are three general approaches to structural classification schemes. First there are loading-oriented classification schemes, a listing of tall building structural members and subsystems by the loads they resist. Second are the material-oriented classifications, a listing of tall building structural systems by the main structural material(s) used. Third, there is the framing-oriented classification system, a listing of tall building structural systems by their framing method.

In the following sections the different approaches and the appropriate classifications are grouped and discussed. General advantages and disadvantages to each approach are also presented.

A. Loading-Oriented Classification

The loading-oriented classification scheme organizes the structural components and subsystems according to the type of load that is resisted -- whether gravity, lateral, or energy dissipation (Council, Committee 3, 1980). Tables 1 and 2 are examples of this approach.

The components and members that make up the load resisting groups can be thought of as structural "building blocks" from which all tall building structures are constructed. One way to categorize a structural system is to define the combinations of elementary structural building blocks that are employed in the structural system. In fact, this is how to classify a structure by the loading-oriented approach. These building blocks are, of course, not arranged haphazardly, but are integrated in such a way as to provide the most adequate support and stiffness while conforming to the architectural plan and maintaining overall economy.

The classification procedure for this type of approach is to group all of the structural components and subsystems presently in use in tall buildings by load resistance characteristics; and to each building that is to be classified, assign various items from each group to define that particular structural system.

The classification that was developed by Committee 3 of the Council on Tall Buildings and Urban Habitat (1980) is such a loading-oriented classification. It groups "building blocks" based on a listing of vertical load-resisting members, horizontal load resisting subsystems, and energy dissipation systems (see Table 1). The items grouped together to form the vertical resisting members include columns, bearing walls, hangers, and transfer girders. The items that form the lateral load resisting members include moment resisting frame, braced frame, shear walls, and combination systems. Items grouped under combination systems are tubes and core interactive structures, and are called "combination" because they usually resist both lateral and vertical loads.

Lu (1974) has presented a classification method using the same basic approach, namely, a listing of vertical load-resisting members, horizontal load-resisting subsystems, and energy dissipation systems. This arrangement is shown in Table 2. A more detailed listing of lateral load resisting subsystems is included, which clearly indicates the many combinations of lateral load resisting subsystems employed in the design of tall buildings.

Generally, the main advantages of a loading-oriented classification are:

1. It provides a strong lead to the structural design. When designing a tall building structure, a loading-oriented classification suggests which structural components and subsystems are available and which loads they generally

resist.

2. It accommodates the many geometric forms and configurations without defining them specifically, and thus can be applied to virtually any tall building.

The main disadvantages of this type of classification are:

1. It cannot render a consistent physical description of the building. This is due to the many and varied ways these building blocks can be integrated to create a particular structural system.
2. It implies that certain structural members resist only one particular loading condition. In reality, the objective is to have all members resist loads from as many sources as possible and thus create a more efficient structural system.

B. Material-Oriented Classification

A second method of classifying structures is a material-oriented classification. This method separates structural systems on the basis of structural material (concrete, steel, masonry, or wood, or mixed). These distinctions are obvious and valid because many structural systems differ significantly depending on which structural material is used. The variables associated with concrete structures might be the ultimate strength of concrete, the slump of the mix, curing time, amount of pretension, or placement of reinforcing bars, most of which are not applicable to steel, masonry, or wood structures. The variables for a steel or masonry structure are also unique to those particular structural materials. Tables 3 through 6 list classification schemes that use this approach.

Khan (1974) used a material-oriented classification to discuss the different responses of various steel, concrete, and mixed structural systems to lateral loads (see Table 3).

This approach is also used by the British Steel Corporation (1972) as seen in Table 4 for the classification of tall steel structures.

A classification of tall building structural subsystems based on

the lateral resistance of different construction materials was developed by Iyengar (1980), and the subsystems are shown in Table 5.

Committee 21A of the Council on Tall Buildings and Urban Habitat also has developed what could be called a material-oriented classification, subdivided according to framing type and applicable to tall concrete structures. This classification is shown in Table 6. A major advantage of this particular classification scheme is that each concrete structural system is examined in chart form. By doing this, a logical comparison of the similarities and differences of each system can be achieved, which helps to give a "feel" for each type of system. The three main parameters examined in this chart are the difficulty of engineering, architecture, and construction of the various structural systems.

The main advantage of a material-oriented classification is that it illustrates the differences that exist between structural systems created from different materials.

The main disadvantage is the possible redundancy because many geometric structural schemes are not limited to one construction material. For example, a frame structure can be made of concrete, of steel, or of a combination of both.

C. Framing-Oriented Classification

A third classification system is the framing-oriented or "descriptive" scheme. This approach attempts to classify tall building structural systems according to a description of the structural framing system. Tables 7 through 11 give examples of the use of this approach.

The classification scheme shown in Table 7 was used in an extensive worldwide survey of tall buildings and their characteristics conducted by the Council (Beedle et. al., 1980). The system consists of a word or phrase which (traditionally) represents a certain type of structural system. In Schueller's (1977) classification shown in Table 8, primary emphasis is given to visual and descriptive analysis of the structural systems. He lists 14 separate tall building structural systems.

The Applied Technology Council (1978) groups structural systems on the basis of similar lateral drift characteristics and natural

frequencies. The numerical coefficients developed for each structural system are for use in the ATC "equivalent lateral force procedure and model analysis". This document is applicable to all structures and is not restricted to tall buildings.

Drosdov and Lishak (1978) developed a classification scheme that categorizes the different structural systems into four primary loadbearing systems and six secondary (combination or hybrid) loadbearing structures (see Table 10 and Fig. 3). The six secondary systems are, in fact, combinations of the four primary structures. This classification is part of a study of the dynamic response of different tall building structures.

Table 11 contains a structural classification scheme developed at an early stage of the project which separated the structure into three categories: the structural framing system, the "augmentative" structural subsystem, and the floor framing system (Falconer, 1981). The structural framing system is defined as the primary load resisting system of the structure. The augmentative structural subsystems are the subsystems which are "added" to the primary load resisting system to create a stronger and/or stiffer total structure. The floor framing system transmits the occupancy loads to the structural framing system, and may also serve to transmit lateral loads along its length between the vertical members.

The basis for classifying structures by this approach is as follows:

1. There is one and only one primary load resisting system in a tall building.
2. The number of augmentative structural subsystems in a structure vary from case to case.
3. There is one floor framing system that can be identified per building.

The main advantages of a framing-oriented structural classification scheme are as follows:

1. It groups together structures that, by virtue of their framing system, respond similarly to a load (i.e., frame, tube, bearing wall, etc.). This is important when one wants to compare the performance of various systems and

their response to load.

2. It avoids the redundancies inherent in the other approaches. The loading-oriented approach is redundant because one member can resist more than one loading system; and the material oriented approach is redundant if one system is constructed from different materials.

The main disadvantage is also a point in its favor: it both requires details for, and yet accommodates, the many different combinations of systems and subsystems that can be incorporated into a structure.

4.2 Proposed Classification Scheme

After consideration of the various systems identified in the literature and a consideration of the advantages and disadvantages of each, the framing-oriented classification scheme contained in Table 12 was selected and further developed to meet the following conditions:

1. The classification scheme must be simple in concept and application, yet detailed enough so that useful comparisons can be made.
2. The classification must be broad in scope in order to be usable in further studies, specifically, a comparison of the responses of different high rise structural systems to earthquakes and other loads.
3. The classification should be compatible with a computer-oriented system for storing information, retrieving it, and making comparison between the response of similar systems.

This framing-oriented classification scheme is one that separates the structure into four major categories: the structural framing system, the bracing system, the floor framing system, and the building configuration system. In the discussion that follows, these categories are identified as "Levels", the major subgroups being identified in Fig 4.

As noted earlier and illustrated in Fig. 3, the structural framing system consists of four major or prime groups:

1. the bearing wall system (identified as "wall")
2. the core system
3. the frame system
4. the tube system.

These four prime groups are shown in Table 12 as a "Level A" in the structural system hierarchy. The hybrids and the variations of each of these structural systems have been listed in an organized way beneath each of the above four primary structural systems. The numerical designations are intended to provide a basis for grouping like systems and subsystems together for the purpose of analysis and evaluation. The primary systems are further described as follows:

1. A bearing wall structure is comprised of planar, vertical elements, which form all or part of the exterior walls and in many instances the interior walls as well. They resist both vertical and horizontal loads. Examples are shown in Fig.5.
2. A core structure is comprised of load-bearing walls arranged in a closed form, usually with the mechanical and vertical transportation systems concentrated in this vertical shaft, allowing the building flexible space beyond the core. The core can be designed to resist vertical and/or horizontal load. Examples are shown in Fig. 6. In one group, shown in the upper part of the figure, there is a central core from which floors are either suspended or cantilevered. In the other group (lower part of Fig. 6) the cores are separated. They are tubes that are not bundled.
3. A frame structure is usually comprised of columns, beams, and/or floor slabs arranged to resist both horizontal and vertical loads. The frame is perhaps the most adaptable structural form with regard to material and shape, due to the many ways of combining structural elements to adequately support the loads. Examples are shown in Fig. 7.
4. A tube structure is usually comprised of closely spaced exterior structural elements, arranged to respond to a lateral load as a whole, rather than as separate elements. Alternate schemes could include braced tubes and framed tubes or more widely spaced columns with deep

spandrels. The system allows for more flexibility in interior space use, due to the lack of vertical interior structural elements. Examples are shown in Fig. 8.

"Level B" in the hierarchy covers the bracing subsystems and are shown in Table 12. They categorize (1) what type of bracing is employed in the building (K-bracing, diagonal bracing, etc.), (2) whether the bracing is for the frame or the core, and (3) what type of hat or belt truss is employed in the building, if any.

There are five digits in Level B. The first two digits show the type of bracing in plane 1. The next two digits show the type of bracing in plane 2. The last digit is for hat and/or belt truss.

Under the bracing subsystems there are five categories. The first category (numbers 10-16, 20-22) refers to the bracing of the frame. Core bracing is divided into two categories, steel core bracing (numbers 30-36, 40-42) and concrete core bracing (numbers 80-85). The next category refers to the moment resisting frame (numbers 50-53). The last category refers to the shear wall bracing (numbers 60-65).

"Level C" in Table 12 covers the floor framing subsystem. The floor system transmits occupancy loads to the framing system, and it may also serve to transfer lateral forces, acting as a diaphragm and as an integral part of the framing system. The basic categorization is according to material and construction method.

"Level D" in Table 12 covers the building configuration subsystem. By this is meant the vertical and horizontal structural symmetry or discontinuity. It uses the ATC classification system with regard to regularity (ATC, 1978) but also identifies the various above-grade load transfer systems most commonly employed in tall buildings.

The methodology for arriving at a classification number for any structure is as follows:

1. Identify which of the four prime systems (wall, core, frame, or tube) describes the structure.
2. Scan Table 12, Level A (and the corresponding figure) for the specific structural system used. (For example, a frame with solid core is No. 58.) The numbers that

correspond to that system are the first two digits of the classification number: "Frame 58"

3. Scan Level B in Table 12 (and the illustrations in Fig. 10) for the specific bracing subsystem used. (Example: frame bracing, double diagonal bracing is identified as "12" and no hat or belt truss is identified as "0")
4. Scan Level C in Table 12 for the specific floor framing subsystem used. (Example: concrete beam and slab, identified by the number "24")
5. Scan Level D in Table 12 with regard to vertical and horizontal regularity and symmetry. (Example: Irregularity in both plan and elevation configurations and load transfer girder, identified by No. 01011)

An example of how the generated number will appear is thus:

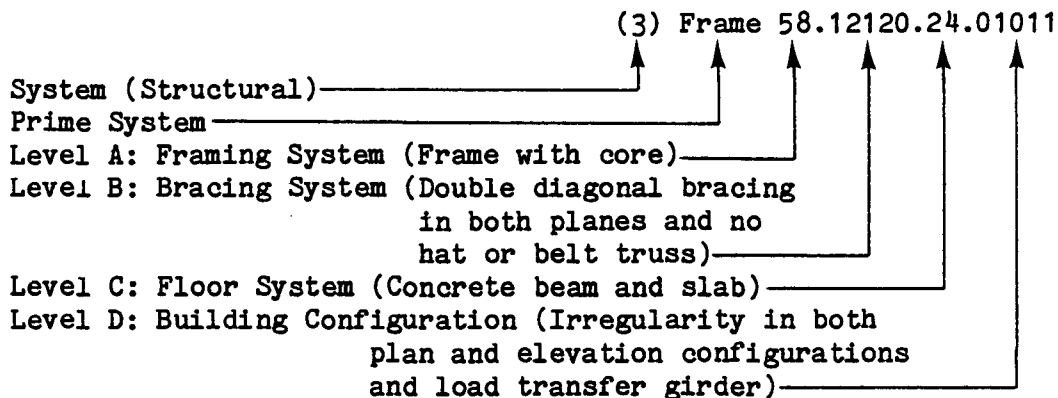

The "3" at the beginning identifies the overall tall building system; the structural system in this case. These "system" numbers correspond to the Council on Tall Buildings and Urban Habitat identification of the major tall building systems. They are listed in Fig. 1. The chosen example would indicate a frame with solid core (58) , with x-bracing in both directions and no belt truss (12120), concrete beam and slab floor (24), with irregularity in both plan and elevation configurations and load transfer girder (01011).

For purposes of standardization, if the classification is unknown (the floor framing system, for example), the space would be filled in by (XX). If a subsystem is known not to exist (the building has no bracing, for example), the space would be filled in

442.3

with zeros (00). If it is not known whether an element is there or not, use (??).

Figure 9 is a sample classification chart, with some sample buildings classified. The numbers shown in Fig. 9 corresponding to the structural system are retrieved from Table 12. The numbered designations are intended to provide a basis for grouping like systems and subsystems together along the lines shown in Table 12 and the example structures shown in Figs. 5 through 8.

5. STRUCTURAL MATERIAL SYSTEMS

Since the beginning of high-rise construction, structural material concepts have been changing constantly. In the nineteenth century the two most commonly used structural materials were masonry and iron. It was soon discovered that the type of structural system for which masonry is best suited (the bearing wall system) is not very efficient when applied to tall buildings. A remarkable use of masonry was in the 16-story Monadnock Building (1891) in Chicago, in which the lower walls were designed to be more than six feet thick (Khan, 1973).

Frame systems became more and more prevalent in tall structures around the turn of the century. This type of system was first made possible by using iron, and later, steel. The first example of a tall building totally supported by an iron framework was in 1883, with the start of construction of the 10-story Home Insurance Building. Reinforced concrete became a common structural material during this period. In 1903, the 16 story Ingalls Building was constructed of reinforced concrete (Schueller, 1975).

Today, the main high-rise structural materials are steel, reinforced concrete, prestressed concrete, masonry (reinforced or not), and composite (steel and concrete). Many structures containing structural cores use a different material for the core than for the framing. Therefore, when classifying the material of a structure, two digits are needed. The first represents the main framing system (wall, core, frame, or tube), and the second represents the structural core (if applicable, as in the case of a frame and core or a tube-in-tube system). Table 13 contains a classification of the material system.

6. MECHANICAL SYSTEMS

This chapter will identify and categorize the major factors common to high-rise mechanical systems: heating, ventilating, and air-conditioning (HVAC), and plumbing. A preliminary classification scheme is presented in Table 14 (for HVAC) and in Table 15 (for plumbing). The subject of vertical transportation is covered in the following chapter.

The invention and improvement of tall building mechanical systems have made it possible for the high-rise to become an attractive, livable environment. In tall buildings erected before the general adoption of air conditioning, perimeter spaces were necessary for natural ventilation from openable windows. Dead air spaces in the interior were possible, and the general efficiency of total usable space was compromised. After forced air HVAC systems became accepted, the entire floor plan became the usable office space, and the efficiency of the floor space was improved (ASHRAE, 1976).

Plumbing system concepts in tall buildings went unchanged longer than any other mechanical system. The method used almost exclusively until the late 1950's and early 1960's to increase water pressure was that of single speed pumps carrying water to various gravity tanks. It is known as the gravity tank system (Council, Committee 2B, 1980). At that time, variable speed pumps and pump controls were developed to a point where booster pump systems started to replace gravity tank systems. Today, the booster pump system is specified almost exclusively (Steele, 1975).

6.1 Heating, Ventilation, and Air Conditioning

The primary purpose of a heating, ventilation, and air conditioning system is to provide a specific set of pre-determined environmental conditions.

Table 14 lists the different types of HVAC systems that are available (ASHRAE, 1976). Most of the requirements of a particular building can be met by any one of several possible systems. The four general heating systems categories are forced air, steam heating, water heating, and electric panels.

The cooling system categories are all-air, air-water, all-water, multiple unit systems (air conditioners in windows) and

combinations of these.

A. Heating Systems

1. Forced Air Heating

In forced air systems, the air circulation is accomplished by motor driven centrifugal fans (blowers). The generally cited advantages of forced air heating are as follows (ASHRAE, 1976):

1. The unit may be placed anywhere in the structure
2. Circulation of air is positive, and air may be cleaned with filters
3. Humidity control is readily obtained
4. The same air distribution may be used for cooling if so designed.

2. Steam Heating

A steam heating system uses the vapor phase of water to supply heat, connecting a source of steam to a suitable terminal heat transfer unit. Steam heating systems are also referred to as central or district heating systems. The generally cited advantages of steam heating are as follows:

1. Steam pipes are smaller than air ducts, and thus are more flexible with regard to space requirements.
2. Individual terminal heat control is possible.
3. The installation is less expensive to build and maintain than fixed air or water heating systems.

3. Water Heating System

A water system is one in which hot water is used to convey heat to terminal transfer units. The generally cited advantages are as follows:

1. It provides a simple means of perimeter heating, by introducing heating along entire outdoor exposures through the use of baseboard, finned radiation, or radiant cycling panels.
2. It requires fewer specialists for maintenance.
3. The same water distribution system can be used for cooling, if so desired.

4. Electric Heating

An electric heating system uses electrical resistance to meet space heating requirements. The usually cited advantages of electric heating are as follows:

1. It is clean, compact, and safe.
2. It is simple to distribute and control.
3. It has a low initial cost.
4. It can be used to supplement other heating systems.

A typical example of mechanical system designator is as follows:

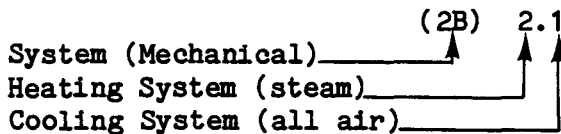

The first digit after the parenthetical designator represents the heating subsystem and the second digit represents the cooling system.

B. Cooling Systems

1. All-Air Systems

An all-air system is defined as a system providing complete cooling capacity by an air stream supplied by the system. It is usually accomplished by forced air (ASHRAE, 1976). All-air systems

may be classified into two basic categories:

1. Single path systems -- those which contain the main heating and cooling coils in a series flow path, using common duct distribution to feed all terminals.
2. Dual path systems -- those which contain the main heating and cooling coils in a parallel flow path, using one duct for heating and one duct for cooling.

The usually cited advantages of an all-air system are:

1. Centralized location of major equipment
2. Wide choice of placement options
3. Ready adaptation of heat recovery systems
4. Adaptable to winter humidification
5. Design freedom for optimum air distribution.

The usually cited disadvantages of an all-air system are:

1. The additional duct clearance requirements
2. The long hours of fan operation in cold weather required by perimeter heating.

2. Air-Water Systems

In the all-air system, the building space is cooled solely by air. In contrast, the air-water system is one in which both air and water are distributed to perform the cooling function. Air-water systems are categorized as follows:

1. The two-pipe system -- a system which consists of one supply pipe and one return pipe, along with conditioned air from a central source.
2. The three-pipe system -- a system which consists of one hot supply pipe, one cold supply pipe, and a common

return pipe.

3. The four-pipe system -- a system which consists of a separate hot loop and cold loop.

The air-water system has the following advantages:

1. Because of the greater specific heat and much greater density of water compared to air, the cross sectional area required for the distribution pipes is much less for the same cooling task.
2. Individual room thermostat control is possible.
3. With all-air systems, the size of central air conditioning apparatus is reduced.

The air-water system has the following disadvantages:

1. Controls tend to be complex.
2. The system is not applicable to spaces with high exhaust requirements, and/or high dehumidification requirements.

3. All-Water Systems

All-water systems accomplish cooling solely by the distribution of chilled water to terminal units located throughout the building. All-water systems are categorized as follows:

1. Two-pipe systems
2. Three-pipe systems
3. Four-pipe systems

The all-water system has the following advantages:

1. No ventilation ductwork space is required.
2. Individual room thermostats are possible.

The all-water system has the following disadvantages:

1. Total lack of humidity control.
2. Dependence on natural ventilation.

6.2 Plumbing Systems

The primary purpose of the plumbing system is to provide adequate water pressure at all times to all parts of the building. This entails delivering the water at the correct pressure to all locations and requires the handling of the discharge. Plumbing systems can be classified into three categories: the pressure boosting system, the hot water system, and the chilled water system. (The classification system is given in Table 15.)

A. Pressure Boosting System

1. Gravity Tank System

The gravity tank system consists of an elevated tank of adequate capacity for which single speed pumps are used to raise the water to fill the tank. When the water level in the tank drops to a predetermined level, the pumps bring water up until the tank is full (Steele, 1975).

Compared to other pressure boosting systems, the gravity tank system has the following advantages:

1. No sophisticated controls are required
2. It is most reliable in case of power failures
3. It requires minimum maintenance
4. It provides additional reserve capacity for fire protection
5. Pump head is less than is required in other systems, and therefore uses less energy
6. There are minimum pressure variations in the distribution system.

The gravity tank system has the following disadvantages:

1. The tank must be elevated
2. The weight of the tank and water may increase structural costs
3. The tanks require interior maintenance
4. If there is a tank failure, large quantities of water will be released.

2. Hydropneumatic Tank System

The hydropneumatic tank system consists of a series of tanks at various locations in the building with pumps to raise the water to the tanks. The hydropneumatic tanks are also known as pressure tanks, because the tanks use compressed air to achieve the desired pressure in the line. They are smaller than the gravity tanks.

Compared to the gravity system, the hydropneumatic tank system has the following advantages:

1. The tanks do not have to be elevated
2. Tanks can be located anywhere in the building

It has the following disadvantages:

1. There is the possibility of inside corrosion of the tank due to the addition of air in the tank
2. There can be significant pressure variations (up to 20 psi)
3. Pumps of a higher head are required.

3. Booster Pump System

The booster pump system varies the speed of continuously running pumps to hold a constant discharge pressure under varying flow conditions.

The advantages of a booster system are:

1. Much smaller tanks are required.
2. Usually there is a lower initial cost.

The disadvantages of a booster system are:

1. More sophisticated controls are necessary
2. The constantly running pumps can create a noise problem
3. There is no emergency water supply should the pumps become inoperable
4. Operating costs are high because the pumps do not operate at maximum efficiency.

All of the pressure boosting systems rely on pumps to deliver the required water pressure. Pumps can be either mechanical (combustion type) or electrical, and either single speed or multiple speed. As shown in Table 15, the pumps are included as a part of the pressure boosting system.

B. Hot Water Supply System

The hot water circulating system requires water lines, water heaters, and frequently, pumps which are independent of the main water supply system. A high-rise building plumbing system is usually zoned vertically to maintain pressures within tolerances. For hot and chilled water circulation, these zones can be categorized by the source of pressure. If the pressure source is at the top of the zone (either pump or gravity), it is known as a downfeed zone. The same logic applies to upfeed zones and combination upfeed and downfeed zones (Steele, 1975).

C. Chilled Water Supply System

The chilled water supply system is categorized in a manner similar to the hot water supply system, with upfeed, downfeed and combination zones. See Fig. 11. In addition, however, some high-rise buildings use two other means to supply chilled water. The first is that of bottled water supplied through self contained units. The other method is to have factory assembled refrigeration

442.3

systems installed separately as drinking fountains.

A typical example of a plumbing system designator is as follows:

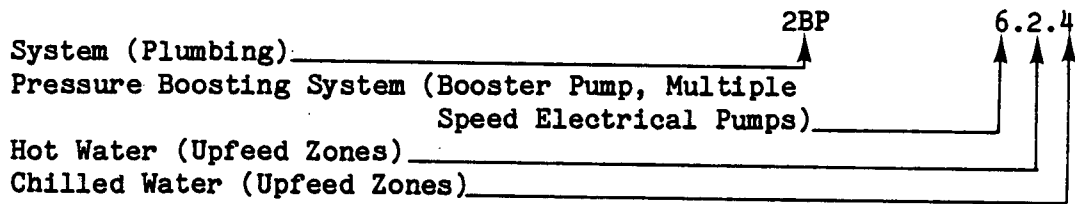

The first number represents the pressure boosting system with the specific pump type used, the second digit represents the hot water supply system, and the third digit represents the chilled water system.

7. VERTICAL TRANSPORTATION

Vertical transportation systems can be separated into three categories: elevators, escalators, and material movers (see Table 16). Elevators and escalators are vertical "people movers". The subject is treated in Chapter SC-4 of the Monograph on the Planning and Design of Tall Buildings (Council, Committee 2A, 1980).

A. Elevators

The invention and development of the passenger elevator (1853-1900) meant that the height of the building was no longer limited by the occupants' willingness or ability to climb stairs. The elevator industry played a major role in setting the stage for the increased size and height of buildings in the early decades of the twentieth century. The increasing demand on elevator capacity and speed brought about further innovations such as multiple batch systems, local and express elevators, and double deck elevators (Adler, 1970).

Basic factors that are considered when designing the elevator system include the number of passengers per minute, their distribution to the floors, the times of arrival and departure, and the floor-to-floor movement. In order to more easily classify elevator systems, four subsystems are defined: the drive, the shaft arrangement, the car arrangement, and traffic flow. Hydraulic elevators are not usually employed in high-rise buildings and therefore are not included.

The drive subsystem consists either of geared or gearless traction elevators. Both geared and gearless traction elevators consist of a car with hoisting rope or cable running over grooves, which is connected to the elevator drive sheave, and attached to a counter weight.

The shaft arrangement can be either in-line (shafts arranged side-by-side) or opposite (shafts separated by passenger lobby). See Figs. 12, 13, 14.

The car arrangement can be either single deck (one car per shaft) or double deck (two compartments per car), each serving alternate floors. See Fig. 15.

The traffic flow of the cars can be local (each car can stop at any and all floors), or express (different cars operate as a local only over a certain range of floors), or sky lobby (a shuttle elevator that goes from ground level to a lobby, where local and/or express elevators are available for access to other levels). See Fig. 16.

B. Escalators

An escalator is a continuously running, unidirectional vehicle providing vertical transportation along an incline (Strakosh, 1967). The two general arrangements of escalators are "parallel" and "crisscross" as shown in Fig. 17. A third possible arrangement, which is called multiple parallel, consists of a number of escalators side by side, serving more traffic than a usual arrangement could handle. Flexibility in handling heavy traffic is provided by operating all units except one in the same direction.

C. Material Movers

Material movers are separated into two categories; pneumatic message tubes and tote box selective vertical conveyors (Council, Committee 2A, 1980). Delivery of more bulky materials is usually handled by service elevators.

8. ARCHITECTURAL SYSTEMS

The two architectural systems considered in this report are the cladding systems and the partition systems (Council, Committee 12A and 12B, 1980, and Time-Saver Standards, 1974).

The building known as the "first skyscraper" was the Home Life Insurance Building in Chicago. One of the major reasons for this designation was that it was the first to employ nonloadbearing exterior walls. The cladding was a curtain wall -- so called because it hung on the framework. The cladding systems discussed in this report will be limited to the nonloadbearing type.

In tall buildings extra consideration is given those aspects to partitions that affect acoustics, fire protection, the covering of elevator shafts, and the response to lateral sway of the building.

8.1 Cladding

For the purpose of classification, cladding systems can be grouped into a number of subsystems: cladding type, material, installation method, material, and glass infill subsystem. (See Table 17.)

There are two general types of cladding systems: custom cladding (designed specifically for one building) and standard cladding (components and details are standardized by the industry).

There are five general installation methods: stick wall system, unit system, unit and mullion system, panel system, and column-and-spandrel system. (See Table 17 and Figs. 18, 19, 20, 21, 22.)

In the stick wall system the components are installed piece by piece, with vertical members (mullions), horizontal members, and windows as the pieces. The advantage of this system is its ease of shipping and the ability to make dimensional adjustments to site conditions. The disadvantage of this system is the necessity of assembly in the field.

The unit system is a preassembled module, usually one floor in height. The unit and mullion system is installed mullions first,

with the preassembled units placed between them. The advantage of the unit system is that good quality control can be maintained at the shop. The disadvantage is that units are usually bulky to transport.

The panel installation system is similar to the unit system, but with the jointing between panels kept to a minimum. The advantages and disadvantages are basically the same as with the unit system.

The column cover and spandrel installation system consists of column and spandrel cover sections, and infilled windows or glazed units. The advantages of this system are relatively easy shipping and latitude of use with any column and spandrel spacing. The disadvantage of this system is the large amount of field work involved with its assemblage.

There are several available structural materials used in curtain walls. They are structural carbon steel, stainless steel, aluminum, bronze, stone, brick, and ceramic tile. These structural materials are required to provide the necessary support and stiffness for the glass infills.

Glass can be classified according to the amount of light that passes through it. Clear glass allows the maximum possible light to pass, and opaque allows the least. Tinted glass is intermediate and is designed to allow a certain specified amount of light into the building. In other cases glass is colored to reflect light for architectural effect.

8.2 Partitions and Walls

The primary function of the partition system in high-rise buildings is the separation of large spaces into smaller ones for privacy, for the organization of work functions, and for fire protection (Council, Committee 12B, 1980).

The classification of partition systems is according to movable (dismountable) partitions and solid (permanent) partitions. See Table 18. All partitions referred to in this section are nonloadbearing.

The solid partitions are categorized according to their

442.3

construction material (either brick, stone, or concrete) as shown in Table 18, Level A. The demountable partitions are categorized according to their support scheme, either post and infill, post and overlay, or postless. The postless partitions must reach from ceiling to floor for support, whereas the post supported partitions can be of any height.

9. UTILIZATION OF CLASSIFICATION SCHEMES

As noted earlier in this report, at present there is no systematic method of making a correlation between the various building systems and the performance of those systems. The classification scheme presented in the previous chapters is aimed at rationally identifying the systems, and with this accomplished, a system-by-system damage correlation can be carried out for past disastrous events and can be applied to future events.

A sample of the kind of information being collected is shown in Tables 19 and 20. Table 19 identifies "Field Tests and Observations" and Table 20 lists the "Case Studies". The major systems involved in the study or event are shown using the numerical designation of Fig. 1. But within these systems a further definition and refinement is required, and this is the function of the classification schemes of Tables 11-18.

Tables 21 and 22 illustrate how the numerical system will be used for those cases in which a building is involved in an event or a field test. For every building that is involved in an event -- an earthquake, a tornado, a field test -- certain systems will be involved. For example, the San Francisco Chronicle Building in the 1906 earthquake involved the structural system (3) and the cladding system (12A) (Table 21). But what is the particular structural system? The particular cladding system? They have to be designated in a sufficiently detailed way so that the systems can be recognized and then correlated with damage as shown in Table 22.

Table 23 is a sample of the systematic identification and arrangement of the data that is anticipated at the present writing, making use of the classification schemes of Tables 12 through 18. The Mori-Sada Building was used for illustration.

10. FURTHER STUDIES

In future work on this subject, the classification schemes need to be reviewed with practicing engineers, suitably modified, and then applied on a trial basis. Such application would use available information on file for existing buildings.

After further refinement, the scheme would then be used in the further surveys that would be made by the Institute for the Study of the High-Rise Habitat in cooperation with the Council of Tall Building to collect information on systems and their response.

11. SUMMARY

A summary of this study is as follows:

1. The tall building systems are identified as the loading systems, the functional systems, the physical systems, and the building implementation systems (Fig. 1). The systems that have been examined in this report from the viewpoint of classification are the structural, material, mechanical, vertical transportation, and selected architectural systems, all of which are subsystems of the physical systems. Primary attention has been given in this report to the structural system.

2. A variety of structural categorizations and classifications were identified from the literatures. Three alternative classification approaches were examined, a loading-oriented approach, a material-oriented approach, and a framing-oriented approach.

3. The framing-oriented approach was selected for use in the suggested structural system classification scheme (See Table 12). The major systems and subsystems in the structural classification scheme are the framing system, the bracing subsystem, the floor framing subsystem, and the building configuration subsystem.

4. A classification number is assigned to each system and subsystem as a basis for computerizing specific information about individual buildings. The numerical designators assist in grouping like systems together for the purpose of comparisons of the response of the various systems to loading.

ACKNOWLEDGEMENTS

The library research was conducted at Fritz Engineering Laboratory and at Mart Science Library, both at Lehigh University, Bethlehem, Pennsylvania. This work was carried out as part of a research program at the Fritz Engineering Laboratory. The thesis research upon which the report is based was a part of the first-named author's civil engineering degree work, which was supervised by the second-named author.

The research was supported in part by a National Science Foundation grant. Acknowledgement is due Dr. George C. Driscoll, Dr. Le-Wu Lu, Dr. Peter Mueller, Dr. Ti Huang, and George Mikroudis for advice as well as Lois M. Nase, Sharon L. Seigler, and Jean M. Johnson, Mart Reference Librarians, for their help in collecting some of the literature used in this report. The Study of earthquake damage by Mikiroudi and Mueller (1984) was particularly helpful in that it provided subsegment revision of the system. The authors are also thankful to Mr. David Beedle, Mr. Pierre Engel, and Mr. Shiunn-Jang Wang for their help in preparing the manuscript.

GLOSSARY

Architectural System. Defines the internal and external partitioning of the building.

Beam. A structural member in which the internal stresses on a transverse cross section may be resolved into a resultant shear and bending moment.

Bearing Wall. A structure composed of planar, vertical elements which usually form the exterior and interior walls. (Example: Monadnock Building, Chicago, IL)

Belt Truss. A truss similar to a hat truss except located between ground level and the top story.

Braced Frame. A frame that relies almost totally on a bracing system for lateral stability.

Bundled (Modular) Tube. A structure that is composed of several framed tubes rigidly attached to form an extremely stiff structure. (Example: Sears Tower, Chicago)

Cladding. The opaque areas of an exterior window wall or curtain wall; i.e., the column cladding or spandrel cladding of a building.

Compartmentalization. Action of dividing a large space into smaller spaces.

Core. A core structure is comprised of load-bearing walls arranged in a closed form, usually with the mechanical and vertical transportation systems concentrated in this vertical shaft, allowing the building flexible space beyond the core.

Curtain Wall. A building exterior wall, of any material, which carries no superimposed loads.

Deep Spandrel Tube. A structure with more widely spaced columns and much deeper spandrels than a typical framed tube, but which achieves tube-like stiffness. (Example: M.L.C. Centre, Sydney, Australia)

Diaphragm. Floor slab possessing a large in-plane shear stiffness.

Ductile Core. A core which behave in a ductile manner under load.

Earthquake-prone Region. Regions where most severe earthquake occur.

Electrical Systems. Equipment that uses electricity in providing services.

Exterior Truss Frame. A frame that has truss members on the exterior to provide lateral stability and stiffness. (Example: Alcoa Building, Pittsburgh)

Fire Codes. The rules that define the fire regulation for the high-rise buildings. **Frame.** A structure composed of columns, beams and/or slabs arranged in a three-dimensional grid to resist both horizontal and vertical loads. Frequently it has a bracing system to help provide lateral stability.

Frame Bracing. Usually a series of structural elements with pinned ends, arranged to deform axially (usually a diagonal, K, or double diagonal) that provide lateral stability and stiffness to the structure.

Framed Tube. A structure that has closely spaced columns rigidly connected to spandrel beams with no interior columns. (Example: World Trade Center, New York)

Framing Oriented Scheme. Includes bearing wall, core, tube and frame, together with the appropriate mixtures of these

systems.

HVAC. Heating, ventilating, and air conditioning.

Hat Truss. A horizontal truss at the top story of a building which rigidly connects the interior core with the exterior structure (usually a frame or tube).

High-rise Building. A building that has occupied floors above the normal operation of an aerial ladder fire truck. This is usually all buildings with the top floor higher than 20m (70ft) above the adjacent street level permitting truck access.

Joist. One of a series of closely spaced horizontal structural members interacting with or supporting a deck.

Mechanical Systems. Those systems required for introducing, circulating, or removing, solids, and air.

Moment Connection. A rigid connection capable of transmitting the bending moment imposed on it.

Moment Resistant Frames. An integrated system of structural elements possessing continuity and hence capable of resisting bending forces. (These frames usually develop minor axial forces.)

Monograph. Treatise or tall building(five volumes) produced by the Council.

Partition. A divider of space within the interior of the building. It can be bearing or nonbearing and it can extend from floor to floor or from floor to ceiling.

Perforated Shell Tube. A structure that resembles a solid shell with exterior windows "punched" out.

Primary Core Cantilevered. A primary core supporting floors through cantilever action.

Primary Core Suspended. A primary core supporting floors by suspending them from top. (Example: Federal Reserve Bank, Minneapolis, MN, Torres Colon, Madrid, Spain)

Primary Core. A structure whose predominant stiffness and strength is provided by one or more cores (bearing walls arranged in a closed form).

Primary Exterior Cores. Primary cores located on the exterior of the structure and floor framed between the cores. (Example: Knights of Columbus, New Haven)

Rigid Frame. A frame with full moment connections to provide lateral stiffness. (Example: Latino Americana Tower, Mexico City)

Semi-rigid Frame. A frame that provides lateral stiffness through connections. Although not fully rigid, lateral stiffness is increased if bracing is added. (Example: Empire State Building, New York)

Shear Wall. A concrete or masonry wall (which or without window openings) resisting the shear, as distinct from a panel with crossed diagonals.

Skin of Building. Outside surfaces: walls, windows, roof.

Sprinkler System. A system of piping and sprinkler head connected to one or more sources of water supply.

Steel Braced Core. Frame bracing arranged to form an open, partially closed, or fully closed box structure that provides lateral stiffness and stability.

Structural (or Shear) Core. An assembly or group of shear walls

joined together to form an open, partially closed, or fully closed box structure, that provides resistance to shear forces resulting from lateral loads.

Structural (or Shear) Wall. A concrete or masonry wall which in its own plane carries shear forces resulting from lateral loads.

Structural Materials. The materials used in the structural system, usually steel, concrete, and masonry.

Structural System. The structural system provides for the strength and stability of the building. The performance of structures is mainly defined by their structural characteristics.

System Approach. A concept of design that takes into consideration the effect of all the environmental and human factors and phenomena that affect the operation of that piece of equipment or that system.

Transfer Girder. A horizontal framing member which transfers vertical loads, for example, at one of the lower floors where some of the columns need to be eliminated to create larger open spaces.

Trussed Tube. A tube that has truss members on the exterior to provide cantilever action with no interior columns.

Tube. A structure that responds to lateral force through cantilever action. A tube is usually comprised of closely spaced rigidly connected exterior elements, although alternate schemes include more widely spaced columns with deep spandrels.

Tube. A tube structure is usually comprised of closely spaced exterior structural elements, arranged to respond to a lateral load as a whole, rather than as separate elements.

442.3

Vertical Shaft. Space in the heart of the building for the mechanical systems and elevators.

Vertical Transportation Systems. The elevators and other lifting devices for vertical movement of personnel and materials include exterior maintenance systems for the cleaning of the building.

Table 1 STRUCTURAL SYSTEMS (Council, Committee 3, 1980)

Framing Systems to Resist Gravity Loads

1. Horizontal Framing Systems - Floor Structures
2. Vertical Framing Systems
 - a. columns
 - b. bearing walls
 - c. hangers
 - d. transfer girders
 - e. suspended systems

Framing Systems to Resist Horizontal Loads

1. Moment Resistant Frames
2. Braced Frames
3. Shear Walls
4. Combination Systems
 - a. Tube Structures
 - b. Multiple Tube System
 - c. Core Interaction Structures
5. New Structural Concepts
 - a. megastructures
 - b. cellular structures
 - c. bridged structure

Energy Dissipation Systems

1. Natural Damping
2. Plasticity of Structural Materials
3. Highly Absorbant Structural Systems
4. Artificially Increased Damping
5. Advanced Foundation Design
6. Aerodynamic Provisions

Table 2 STRUCTURAL SYSTEMS (Lu, 1974)

Gravity Load Resistant Systems

1. Horizontal (floor) Framing
2. Vertical Framing
 - a. bearing walls
 - b. hangers
 - c. load transfer girders

Lateral Load Resistant Systems

1. Moment Resistant Frame
2. Shear Wall or Truss
3. Combined Frame and Shear Wall or Truss
4. Moment Resistant Frame with Stiffening Features
5. Framed Tube
6. Core Structure
7. Combined Framed Tube and Core Structure
8. Framed Tube with Stiffening Features
9. Other Tube Structure

Energy Dissipation Systems

1. Ductile Frame and Wall
2. Damping Systems

Table 3 HIGH RISE STRUCTURAL SYSTEMS (Khan, 1974)

Steel Structural Systems

1. Rigid Frame
2. Shear Truss Frame
3. Shear Truss Frame with Belt Trusses
4. Framed Tube
5. Column Diagonal Truss Tube
6. Bundled Tube
7. Truss Tube without Interior Columns

Concrete Structural Systems

1. Frame
2. Shear Wall
3. Frame-Shear Wall
4. Framed Tube
5. Tube-in-Tube
6. Modular Tube

Table 4 FRAMING SYSTEMS FOR TALL BUILDINGS
(British Steel Corporation, 1972)

1. Rigid Frame
2. Core Type Structure
3. Shear Wall System
4. Braced Structure
5. Hull or Tube System
6. Suspended Structure

Three Means of Resisting Lateral Loads in Structures

1. Shear Wall
2. Rigid Connections
3. Diagonal (Truss) Bracing

Table 5 MIXED STEEL AND CONCRETE SUBSYSTEMS
(Iyengar, 1980)

	LATERAL LOAD RESISTING SUBSYSTEM A	FLOOR FRAMING B	SLAB C	COLUMNS D	WALL PANELS E	CLADDING F
CONCRETE	1. Poured-in-Place Frame	1. One-Way Slab	1. Spiral Core	1. Concrete Tied or Spiral Column	1. Wall Panels Poured-in-Place	1. Solid Masonry Infill
	2. Shear Walls Core or Elsewhere	2. Two-Way Slab	2. Poured-in-Place Slab	2. Precast Tied or Spiral Column	2. Wall Panels Precast	2. Architecturally Exposed Concrete
	3. Shear Wall-Frame Interaction	3. Flat Slab	3. Precast Plank and Fill	3. None	3. None	3. Precast Panel-No Window Opening
	4. Exterior Framed Tube	4. Joist Slab	4. Precast Concrete Floor Panels			4. Precast Panel-Window Opening
	5. Tube-in-Tube	5. Waffle Slab				5. Precast Composite Formwork Cladding
	6. Modular Tube	6. Precast Beams				6. Stone Cladding
	7. Wall Panels					
COMPOSITE	8. Steel Bracing with Precast Concrete Columns	7. Concrete Encased Composite Steel Beams	5. Metal Deck & Fill-Composite	4. Encased Steel Columns	4. Wall Panels with Misc. Steel Embedments	7. Composite Steel Cladding
	9. Wall Panels with Steel Embedments	8. Unencased Composite Steel Beams	6. Metal Deck & Fill Composite-Reinforcement for Negative Bending	5. Filled Tube Columns		
	10. Steel Reinforced Concrete Construction	9. Encased Beams with Misc. Steel Embedments		6. Encased Columns with Misc. Steel Embedments		
STEEL	11. Welded Moment-Resistant Frame	10. Rolled Beam-Non-Composite	7. Metal Deck & Fill-Non-Composite	7. Rolled or Built Up Steel Column-Exterior		8. Non-Composite Steel Cladding
	12. Simple Steel Frame	11. Truss or Joist-Non-Composite		8. Rolled or Built Up Steel Column-Interior		9. Aluminum Cladding
	13. Shear Truss	12. Welded Two-Way Grid		9. All Columns-Steel Built Up or Rolled		10. Non-Participating Skin
	14. Shear Truss-Frame Interaction				None	
	15. Shear Truss-Belt Truss System					
	16. Framed Tube					
	17. Diagonalized Tube					
	18. Modular Tube					

Table 6 TALL CONCRETE STRUCTURES
(Council, Committee 21A, 1978)

Material		Story height, in meters (feet) (11)	Total height (12)	Remarks	
Reinforcing steel (9)	Formwork (10)			General (13)	Interface ^a (14)
complex, requires shop fabrication	complex, often special engineering	depends on allowable column size	limited only by drift and sway	very flexible in use	excellent
complex, re- quires a good fabricator	often slip formed	unlimited	limited only by practi- cality	limited by basic geom- etry selected	no major problems
very complex	complicated	normal limits	limited only by practi- cality	limited by basic geom- etry selected	no major problems
simple	usually jump formed— simple— may be slip formed	usually 3.7 to 4.6 (12 to 15)	usually limited to 20-30 stories	walls must be continuous for economy	may severely limit mechani- cal ducts and shafts
complex, requires shop fabrication	complex, requires spe- cial engineer- ing	depends on column size— shear wall efficiency contributes	limited by practicality	moderately flexible in use	good
complex	complex	3.7 to 4.3 (12 to 14), or truss depth	limited by test data	must have engineering involvement from the beginning	must frame specifically for these facilities
shop fabrica- tion	engineered reusable	usually 3.7 to 4.6 (12 to 15)	presently to about 30 stories	should work very close to engineer of manufacturer	must be handled specially
very complex	on diagonal itself—other is basic	not critical 45° for maximum efficiency of braces	practicality of bracing	variety of systems, single or mul- tiple diagonals, K bracing (verti- cal or horizontal), lattice, knee, etc.	
not difficult	not dependent on any brac- ing	floor heights of supporting structure	requires height and capacity of supporting structure	only suitable with certain conditions	usually limited to small ap- pendages such as elevator shafts, etc.

Table 6 continued: TALL CONCRETE STRUCTURES

Material		Story height, in meters (feet) (11)	Total height (12)	Remarks	
Reinforcing steel (9)	Formwork (10)			General (13)	Interface ^a (14)
complex, requires shop fabrication	complex, often special engineering	depends on allowable column size	limited only by drift and sway	very flexible in use	excellent
complex, re- quires a good fabricator	often slip formed	unlimited	limited only by practi- cality	limited by basic geom- etry selected	no major problems
very complex	complicated	normal limits	limited only by practi- cality	limited by basic geom- etry selected	no major problems
simple	usually jump formed— simple— may be slip formed	usually 3.7 to 4.6 (12 to 15)	usually limited to 20-30 stories	walls must be continuous for economy	may severely limit mechani- cal ducts and shafts
complex, requires shop fabrication	complex, requires spe- cial engineer- ing	depends on column size— shear wall efficiency contributes	limited by practicality	moderately flexible in use	good
complex	complex	3.7 to 4.3 (12 to 14), or truss depth	limited by test data	must have engineering involvement from the beginning	must frame specifically for these facilities
shop fabrica- tion	engineered reusable	usually 3.7 to 4.6 (12 to 15)	presently to about 30 stories	should work very close to engineer of manufacturer	must be handled specially
very complex	on diagonal itself—other is basic	not critical 45° for maximum efficiency of braces	practicality of bracing	variety of systems, single or mul- tiple diagonals, K bracing (verti- cal or horizontal), lattice, knee, etc.	
not difficult	not dependent on any brac- ing	floor heights of supporting structure	requires height and capacity of supporting structure	only suitable with certain conditions	usually limited to small ap- pendages such as elevator shafts, etc.

Table 7 DATA BASE STRUCTURAL SYSTEMS (Joint Committee, 1973)

1. Rigid Frame
2. Braced Frame
3. Staggered Frame
4. Frame With Load Bearing Walls
5. Frame With Central Core
6. Frame With Shear Walls
7. Core With Cantilevered Floors
8. Core With Suspended Floors
9. Framed Tube
10. Braced Tube
11. Tube-in-Tube

Table 8 COMMON HIGH RISE STRUCTURES (Schueller, 1975)

1. Bearing Walls
2. Cores and Bearing Walls
3. Self Supporting Boxes
4. Cantilevered Slab
5. Flat Slab
6. Interspatial
7. Suspended
8. Staggered Truss
9. Rigid Frame
10. Core and Rigid Frame
11. Trussed Frame
12. Belt-Trussed Frame and Framed Core
13. Tube-in-Tube
14. Bundled Tube

Table 9 STRUCTURAL SYSTEMS
(Applied Technology Council, 1978)

<u>Type of Structural System</u>	<u>Vertical Seismic Resisting System</u>
1. Bearing Wall System	Light framed walls with shear panels
2. Building Frame System	Shear Walls
3. Moment Resisting Frame System	Special Moment Frames Ordinary Moment Frames
4. Dual System	Braced Frames
5. Inverted Pendulum Structures	

Table 10 STRUCTURAL SCHEMES (Drosdov, Lishak, 1978)

Primary Structural Systems

1. Framed systems (Frame)
2. System with Flat Walls (Wall)
3. Core-Trunk System (Core)
4. Envelope-Type System (Tube)

Secondary (Hybrid) Structural Systems

1. Frame-Braced System (Frame & Wall)
2. Frame System (Frame & Core)
3. Frame-Envelope System (Tube & Frame)
4. Trunk-Wall System (Core & Wall)
5. Cellular System (Tube & Wall)
6. Trunk-Envelope System (Tube & Core)

Table 11 A TALL BUILDING STRUCTURAL CATEGORIZATION
(Falconer, 1981)

Primary Structural Framing System

1. Bearing Wall
2. Core
3. Frame
4. Tube

Augmentative Structural Subsystems

1. Structural Wall
2. Structural Core
3. Truss System
4. Repeated Girder
5. Moment Resisting Frame

Floor Framing Subsystem

1. Steel
2. Concrete
3. Composite

Table 12 STRUCTURAL SYSTEMS: A FRAMING-ORIENTED
CLASSIFICATION

Level A: PRIME FRAMING SYSTEMS AND COMBINATIONS

BEARING WALL

10 Bearing Wall(BW)
11 BW & frame
12 BW & core

CORE

20 Core(C)
21 Perimeter Core (PC)
22 C w/suspended floors(CS)
23 C w/cantilevered floors(CL)
24 Central Core (CC)
25 Offset Core (OC)
26 C & frame
27 PC & frame
28 CS & frame
29 CL & frame
30 CC & frame
31 OC & frame
32 C & shear walls
33 PC & shear walls
34 CS & shear walls
35 CL & shear walls
36 CC & shear walls
37 OC & shear walls
38 PC & CC

FRAME

50 Frame(F)
51 Simple Frame(SF)
52 Semi-Rigid Frame (SRF)
53 Rigid Frame (RF)
54 F & shear walls
55 SF & shear walls
56 SRF & shear walls
57 RF & shear walls
58 F & core
59 SF & core
60 SRF & core
61 RF & core
62 Exterior truss frame
63 F & braced frame
64 SF & braced frame
65 SRF & braced frame
66 RF & braced frame

TUBE

80 Tube(T)
81 Framed Tube (FT)
82 Trussed Tube (TT)
83 Deep Spandrel Tube (DST)
84 Perforated Shell T (PST)
85 T-in-Tube
86 FT-in-Tube
87 TT-in-Tube
88 DST-in-Tube
89 PST-in-Tube
90 T w/interior columns
91 FT w/interior columns
92 TT w/interior columns
93 DST w/interior columns
94 PST w/interior columns
95 Bundled Tube

Table 12, continued
LEVEL B: BRACING SUBSYSTEM

B1: Bracing (Plane 1 and Plane 2)

FRAME BRACING

- 10 Centrally Brac. Frame
- 11 Single Diagonal Bracing
- 12 Double Diag. Bracing
- 13 Horizontal K Bracing
- 14 Vertical K Bracing
- 15 Knee Bracing
- 16 Lattice Bracing
- 20 Eccentrically Braced Frame
- 21 Eccentric Diag. Bracing
- 22 Eccentric K Bracing

STEEL CORE BRACING

- 30 Centrally Brac. Core
- 31 Sing. Diag. Bracing
- 32 Double Diag. Bracing
- 33 Hor. K Bracing
- 34 Vert. K Bracing
- 35 Knee Bracing
- 36 Lattice Bracing
- 40 Eccentrically Braced Core
- 41 Eccentric Diag. Bracing
- 42 Eccentric K Bracing

MOMENT RESISTING FRAMES

- 50 Moment-Resisting Frame(MRF)
- 51 Ordinary MRF
- 52 Ductile MRF
- 53 Ductile MRF (Dual system)

SHEAR WALL BRACING

- 60 Shear Wall (SW)
- 61 Simple Shear Wall (SSW)
- 62 Coupled Shear Wall (CSW)
- 63 Ductile SW
- 64 Ductile SSW
- 65 Ductile CSW

CONCRETE CORE BRACING

- 80 Core (C)
- 81 Simple Core (SC)
- 82 Coupled Core (CC)
- 83 Ductile C
- 84 Ductile SC
- 85 Ductile CC

Hat and/or Belt Truss

- 0 None
- 1 Belt/Hat
- 2 Single Diagonal Belt/Hat
- 3 Double Diagonal Belt/Hat

Table 12, continued
LEVEL C: FLOOR FRAMING

<u>STEEL</u>	<u>CONCRETE</u>	<u>COMPOSITE</u>
10 Steel	20 Concrete	30 Composite
11 Pre-fabricated	21 Flat Slab	31 Steel beam & slab
12 Steel beam	22 Flat Plate	(SBS)
& Deck	23 Waffle Slab	32 Steel joist
13 Steel joist	24 Beam & Slab	& slab (SJS)
& Deck	25 Joist & Slab(JS)	33 SBS w/ Metal Deck
	26 JS one-way	34 SJS w/ Metal Deck
	27 JS two-way	35 Concrete Encased Beam

LEVEL D: CONFIGURATION AND LOAD TRANSFER

CONFIGURATION

<u>PLAN CONFIGURATION</u>	<u>ELEVATION CONFIGURATION</u>
00 Regular	00 Regular
01 Irregular	01 Irregular
02 Offsets, asymmetric plan	02 Offsets in elevation
03 Eccentricities in lateral resisting system	03 Changes in lateral load resistance or mass
04 Eccentric Core	04 Discontinued shear walls / cores, soft-stories
05 Eccentric shear walls or braced cores	05 Changes in story height
06 Large or irregular diaphragm openings	

LOAD TRANSFER

0. No Special Load Transfer System
1. Transfer Girder
2. Transfer Truss
3. Transfer Arch
4. Transfer Wall Beam
5. Column Collection
6. Portal Frame

Table 12, continued

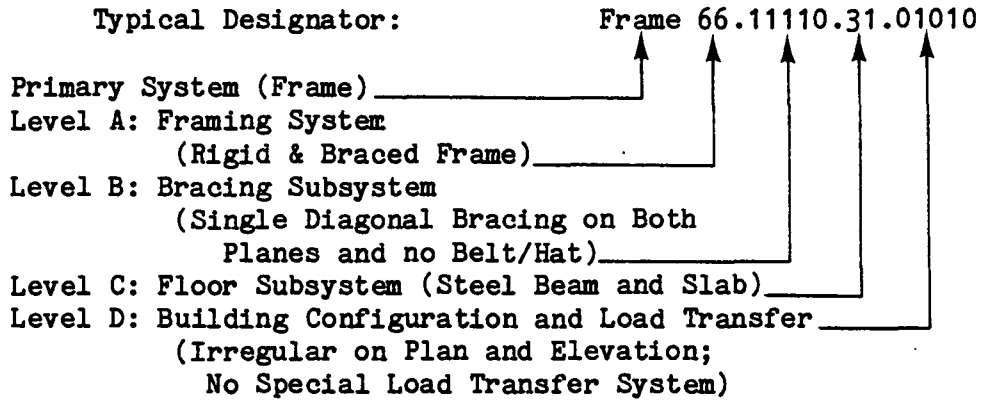

Table 13 STRUCTURAL MATERIAL SYSTEM

A. Primary Material

- Steel
- Concrete
- Mixed

B. Material in Framing System

- 11. Unreinforced Masonry
- 12. Reinforced Masonry
- 21. Reinforced Monolithic Concrete
- 22. Prestressed Monolithic Concrete
- 23. Reinforced Precast Concrete
- 24. Prestressed Precast Concrete
- 25. Mixed Concretes
- 31. Structural Steel
- 32. High Strength Steel
- 33. Mixed Steels
- 40. Mixed Construction -- Composite
- 45. Mixed Systems
- 50. Vertically Mixed
- 60. Wood

C. Material in Core Subsystem

- 1. Reinforced Monolithic Concrete
- 2. Prestressed Monolithic Concrete
- 3. Reinforced Precast Concrete
- 4. Prestressed Precast Concrete
- 5. Structural Steel
- 6. High Strength Steel

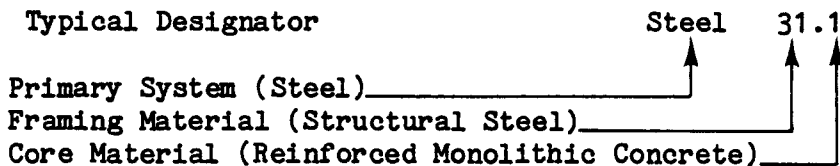

Table 14 HVAC CLASSIFICATION (ASHRAE, 1976)

Heating Subsystem

1. Forced Air
2. Steam Heating
3. Electric Panels
4. All Water
5. Combination

Air Conditioning Subsystem (Cooling)

1. All-Air
2. Air-Water
3. All-Water
4. Multiple Unit
5. Combination

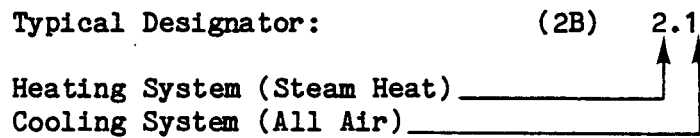

Table 15 PLUMBING SYSTEM CLASSIFICATION (Steele, 1975)

Pressure Boosting System

1. Gravity Tank, Single Speed Mechanical Pumps
2. Gravity Tank, Single Speed Electrical Pumps
3. Hydropneumatic Tank, Single Speed Mechanical Pumps
4. Hydropneumatic Tank, Single Speed Electrical Pumps
5. Booster Pump, Multiple Speed Mechanical Pumps
6. Booster Pump, Multiple Speed Electrical Pumps
7. Combination, Single Speed Pumps
8. Combination, Multiple Speed Pumps

Hot Water Supply System

1. Downfeed Zones
2. Upfeed Zones
3. Downfeed and Upfeed Combination Zones
4. Combinations of Zones

Chilled Water Systems

1. Bottled Water
2. Refrigerated Dispenser Units
3. Downfeed Zones
4. Upfeed Zones
5. Downfeed and Upfeed Combination Zones
6. Combinations of Zones

Typical Designator:

(2BP) 5.2.4

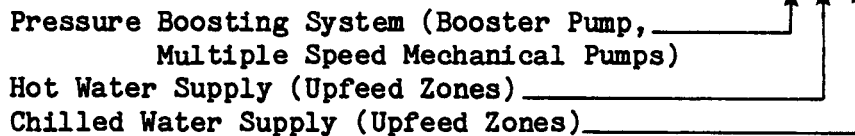

Table 16 VERTICAL TRANSPORTATION SYSTEMS
(Council, Committee 2A, 1980)

Elevators

Drive and Shaft Arrangement

1. Geared Traction, In-Line Elevator Shafts
2. Geared Traction, Opposite Elevator Shafts
3. Gearless Traction, In-Line Elevator Shafts
4. Gearless Traction, Opposite Elevator Shafts

Car Arrangement and Traffic Flow

1. Single Deck, Local Service
2. Single Deck, Express Service
3. Single Deck, Sky Lobby
4. Double Deck, Local Service
5. Double Deck, Express Service
6. Double Deck, Sky Lobby

Escalators (Strakosch, 1967)

1. Parallel
2. Multiple Parallel
3. Parallel Separated
4. Criss-Cross
5. Criss-Cross Separated

Material Movers

1. Pneumatic Tubes
2. Vertical Box Conveyors

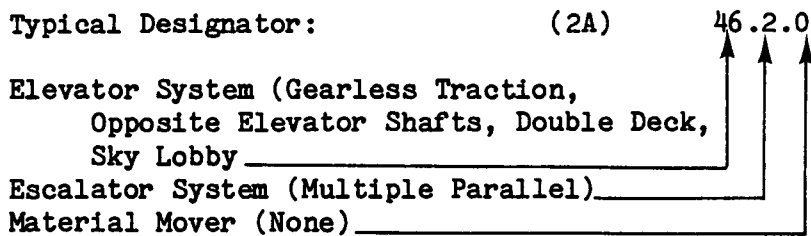

Table 17 CLADDING SYSTEM CLASSIFICATION
 (Council, Committee 12A, 1980)
 (Callender, 1974)

A. Cladding and Glass Type

1. Custom Cladding, Clear Glass
2. Custom Cladding, Tinted Glass
3. Custom Cladding, Opaque Glass
4. Standard Cladding, Clear Glass
5. Standard Cladding, Tinted Glass
6. Standard Cladding, Opaque Glass

B. Cladding Material (other than glass)

1. Structural Carbon Steel
2. Stainless Steel
3. Aluminum
4. Bronze
5. Stone
6. Concrete
7. Brick
8. Ceramic Tile

C. Installation Method

1. Stick Wall Installation
2. Unit Installation
3. Unit and Mullion Installation
4. Panel Installation
5. Column and Spandrel Cover Installation

D. Connection and Jointing Subsystem

(To be Prepared)

Typical Designator: (12A) 3.2.4

A. Cladding and Glass Type (Custom Cladding, Opaque Glass) _____

B. Cladding Material (Stainless Steel) _____

C. Installation Method (Panel Installation) _____

Table 18 PARTITION SYSTEM CLASSIFICATION
(Council, Committee 12B, 1980)

A. Permanent

- 10. Masonry Block
- 11. Concrete Block
- 12. Monolithic Concrete
- 13. Stone
- 14. Precast Panel

B. Demountable

- 20. Wood Framed (Post) and Infill Panels
- 21. Metal Framed (Post) and Infill Panels
- 22. Wood Framed (Post) and Overlay Panels
- 23. Wood Framed (Post) and Overlay Panels
- 24. Postless Panels

C. Connection and Jointing Subsystem
(To be prepared)

Typical Designator: (12B) 12.00

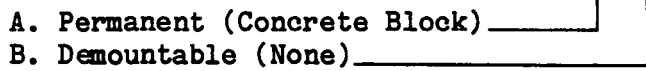

Table 19 TALL BUILDING FIELD TESTS AND OBSERVATIONS

TALL BUILDING FIELD TESTS AND OBSERVATIONS

Project (Building)	Event No. ^c	System(s) involved in Study ^a				Reference ^b
		Loading	Func- tional	Phys- ical	Implemen- tation	
California Medical Center	66-01.1	6,7	36	3,SB	4	Bouwamp, 1966
Commerce Industry and Trade Center	76-01.1	7				Kimpara, 1976
High-Rise Housing	76-03.1		37,A51			Williamson, 1977
High-Rise Housing	76-03.2		37,A51			Williamson, 1977
Main- Montparnasse	76-02.1	7				Kimpara, 1976
Office	79-02.1	7	36	3,12A, 12B		Hansen, 1979
Pruitt-Igoe	78-01.1	6,7		3,21D		Galambos, 1978
Tower Louisa	80-01.1	8A				Council, 1980

(a) Numbers refer to the Council's accompanying system identification number. (Fig. 1)

(b) See citation and abstract in report M262.

(c) refer to Report M272.

Table 20 TALL BUILDING CASE STUDIES

Tall Building Case Studies

Project (Building)	Event No. ^c	System(s) involved in Event ^a Building			Reference ^b
		Loading	Func- tional	Phys- ical Implemen- tation	
Andraus	72-02.1	8A		2A	Council, 1980
Avianca	73-02.1	8A		21D,3	Uribe, 1974
Banco De America	72-12.1	6		3,2B	Mahin, Bert 1975
Bunker Hill Tower	71-02.1	6	2A	2B,30	NOAA, 1973
Holy Cross Hospital	71-02.1	6		3,21D	NOAA, 1973

(a) Numbers refer to the Council's accompanying system identification number. (Fig 1)

(b) See citation and abstract in Report M262.

(c) refer to Report M272.

Table 21 TALL BUILDING HAZARDS AND THEIR RESPONSE
THEREITO

Building	Event no. ^b	Identified System Response Involved in Event	Observed ^a Response Categories	Pre- diction	Reference
SF Chronicle	06-4.1	3.66.1111X.31.0101?	0	-	Council, 1980a
		12A.4.5.5	3	-	Council, 1980a
SF Chronicle	06-4.2	3.66.1111X.31.0101?	1	-	Council, 1980a
James Flood	06-4.1	3.50.5050?.10.00000	0	-	Council, 1980a
James Flood	06-4.2	12A.4.5.5	1	-	Council, 1980a
		12A.4.5.5	3	-	Council, 1980a

(a) Categories as follows:

- 0 = No damage observed
- 1 = Some damage, repairable, not widespread
- 2 = Repair, stiffening, or patching required
- 3 = Extensive damage. Repair and partial replacement possible
- 4 = Total failure

(b) Refer to Report M272.

Table 22 SYSTEMS USED IN TALL BUILDINGS
AND THEIR RESPONSE

System	Building	Event No.	Action under event	Response ^a	
				Observed	Predi
<u>Structural Systems</u>					
3.66.1111X.31.0101?	SF Chronicle	06.4-1	Undamaged	0	(b)
		06.4-2	Undamaged (except for unproted column)	1	-
3.50.50507.10.00000	James Flood	06.4-1	Undamaged	0	(b)
<u>Cladding Systems</u>					
12A.4.5.5	SF Chronicle	06.4-1	Brickwork damaged	3	(b)
12A.4.5.5	James Flood	06.4-2	Spalling around window opening	1	(b)
12A.4.5.5	James Flood	06.4-2	Column protection badly damaged	3	(b)

(a) See footnote on Table 21 for description of response categories.

(b) No dynamic analyses are available.

Table 23 TALL BUILDINGS AND THEIR SYSTEMS

<u>Mori-Sada Building</u>	
<u>Systems</u>	<u>System Designator</u>
Structural Systems (3)	Frame 50.50500.10.0000
Material (9)	Steel 31.1
HVAC	?.?
Plumbing (2B)	5.2.4
Vertical Transportation (2A)	41.0.0
Cladding (12A)	4.1.1
Partition (12B)	12.00
Reference	Wang, 1983

FIGURES**Loading systems**

Gravity (5)
 Temperature (5)
 Earthquake (6)
 Wind (7)
 Fire (8A)
 Accidental Loading (8B)
 Water and Snow ()

Functional Systems

Utilization ()	Parking (33)
Ecological (31)	Ownership, Finance (41)
Site (31)	Operation (41)
Esthetics (30)	Maintenance (41)
Space Cognition ()	Management (42)
Access and Evacuation (2)	Building Services (2)
Infiltration Protection ()	Communication (2)
Environmental (31)	Security (2)
Transportation (2)	Fire Protection (2)
Energy Efficiency (40)	Urban Services (31)

Physical Systems

Foundation (11)	Architectural (12)
Structural Framework (3)	Fitting and Furnishings (30)
Mechanical Systems (2)	Utilities (2)

Building Implementation Systems

Need (28)
 Planning (42)
 Design (42)
 Construction (4)
 Operation (41)
 Demolition (42)

Fig. 1: Tall Building Systems (Beedle, 1980)

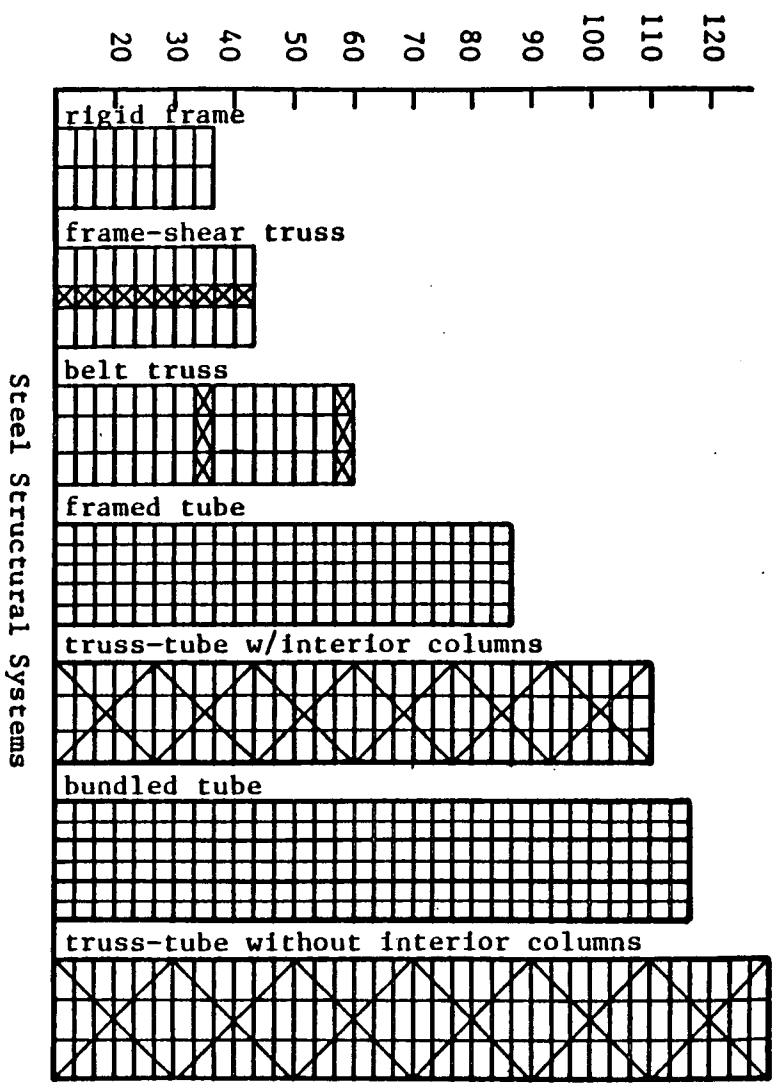
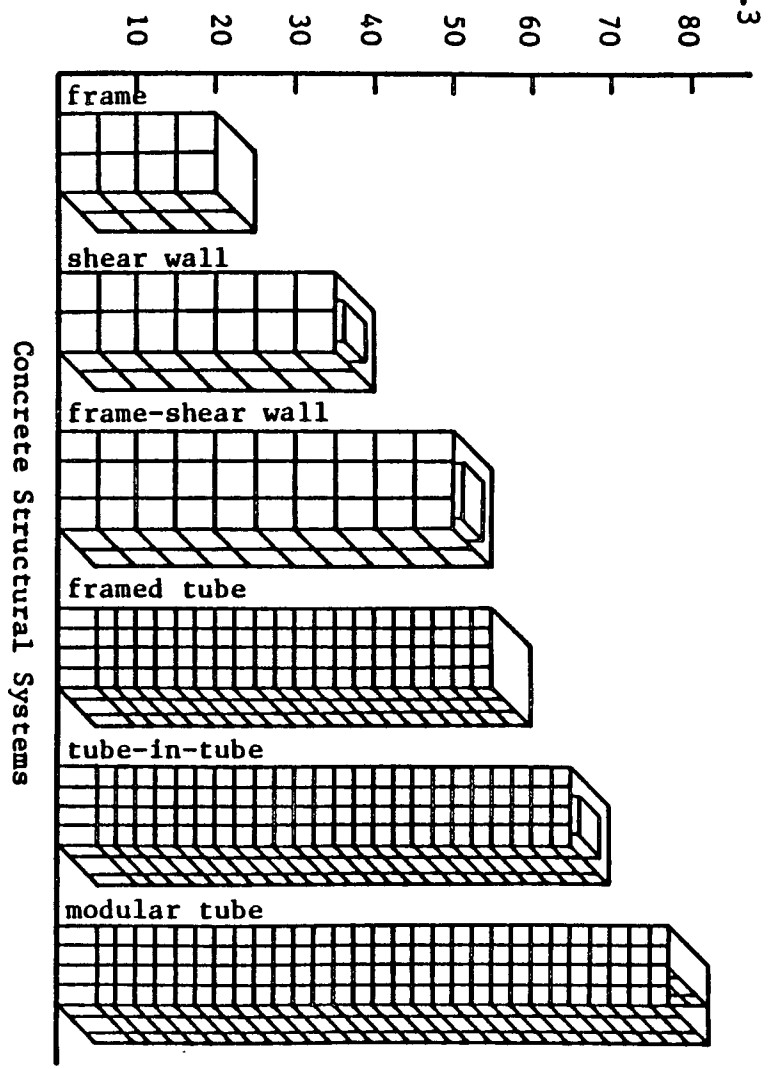

Fig. 2: Structural Systems (Khan, 1973)

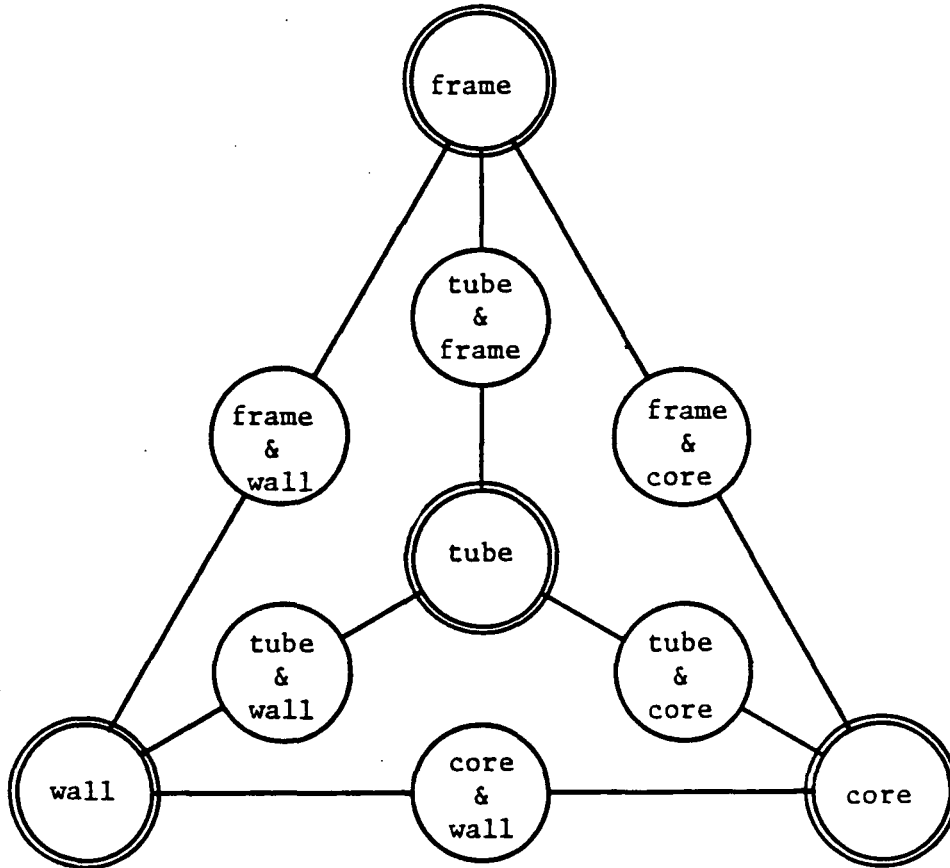

Fig. 3: Classification of Structural Systems of Multi-Story Buildings [Drosdov, Lishak, 1978]

CLASSIFICATION OF STRUCTURAL SYSTEMS

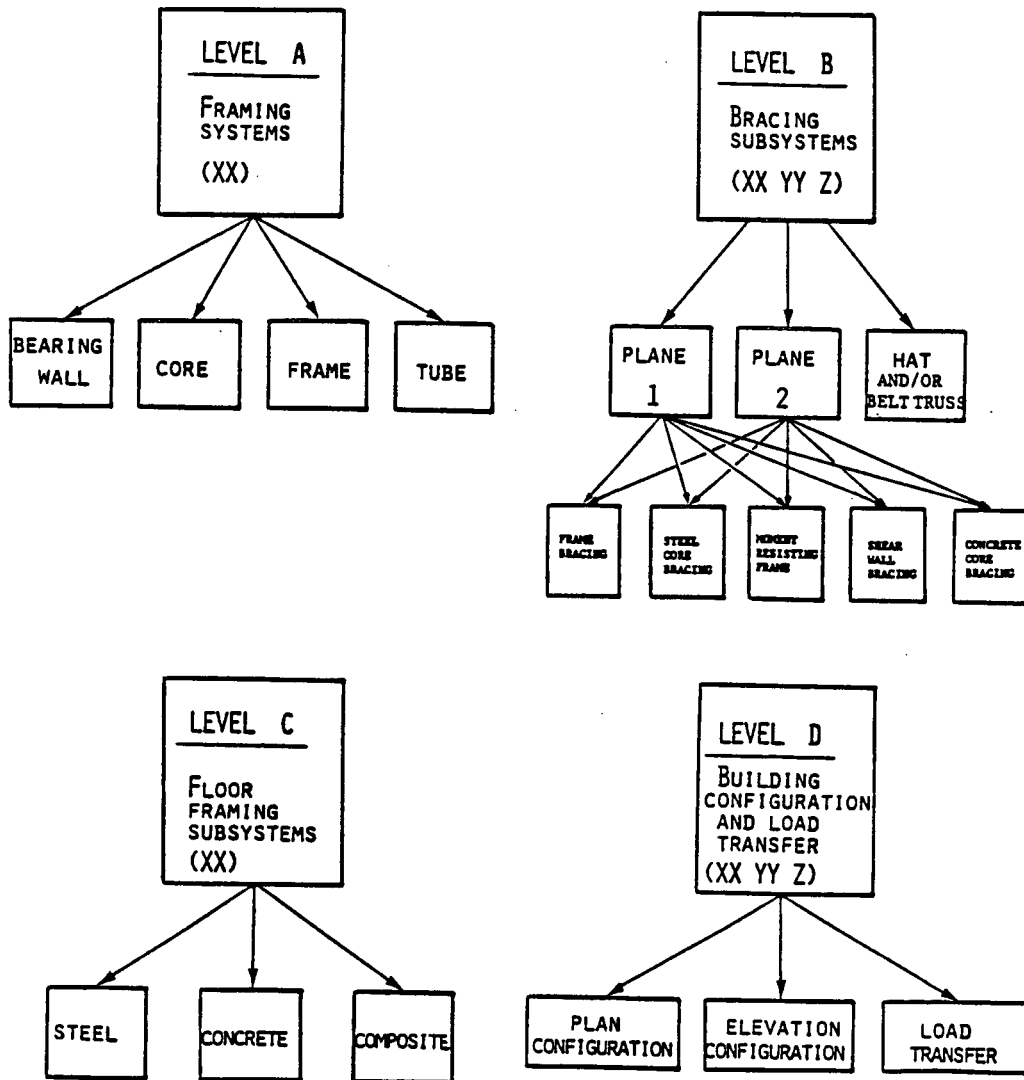
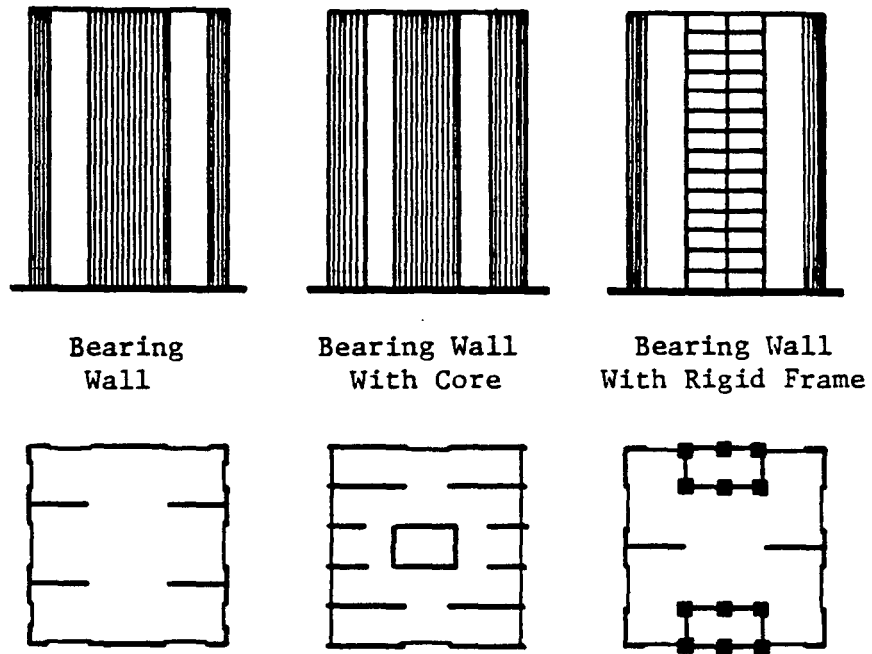

Fig. 4: Classification of Structural Systems



Bearing Wall

Bearing Wall With Core

Bearing Wall With Rigid Frame

Fig. 5: Bearing Wall Systems

442.3

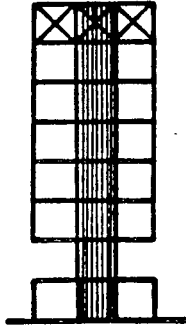

Suspended
Top Truss

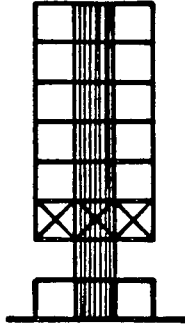

Suspended
Bottom Truss

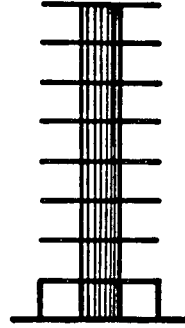

Cantilever
Floors

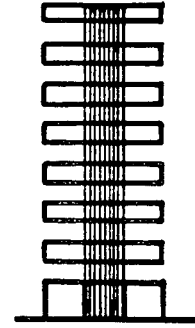

Cantilever
Connected Floors

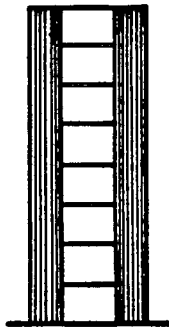
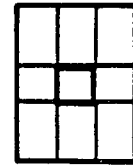
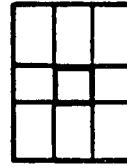
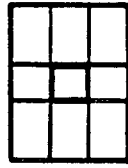
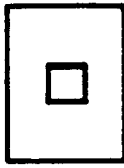

Corner
Core

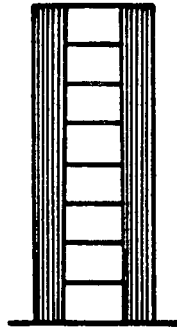

Corner &
Interior Core

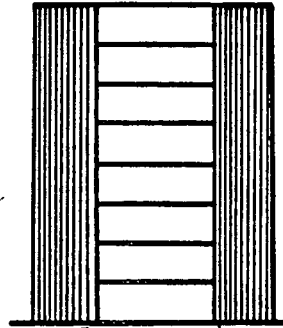

Separated
Perimeter
Core

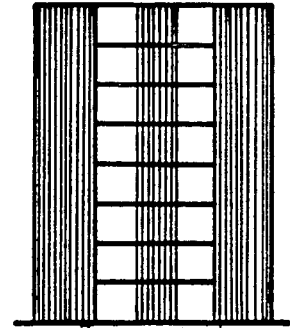

Separated
Perimeter &
Interior Core

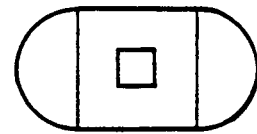
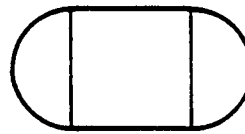
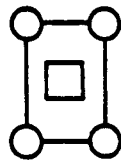
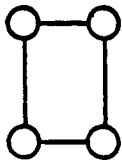
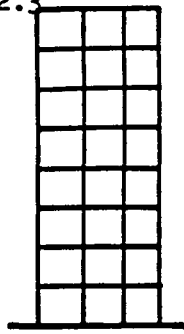
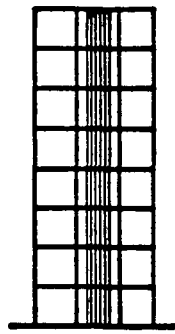

Fig. 6: Core Systems

442.3



Frame



Frame & Solid Core

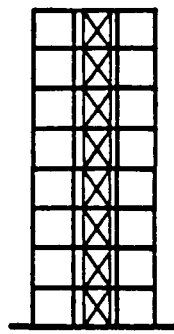

Frame & Braced Core

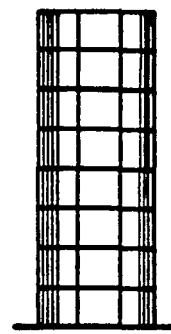

Frame & Shear Walls

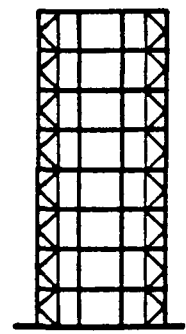

Frame & Wing Trusses

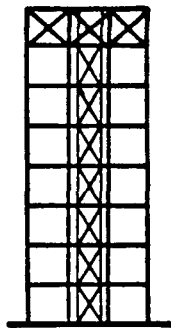
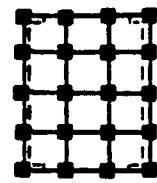
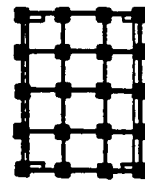
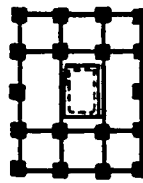
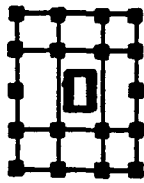
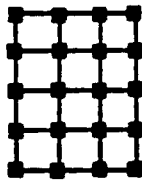

Hat Truss & Braced Core

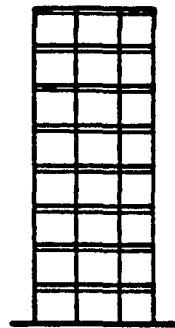

Flat Slab

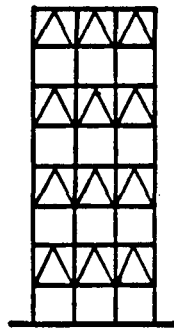

Staggered Truss

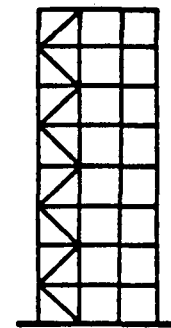

Braced Frame

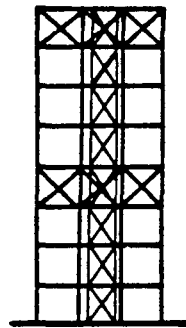

Hat/Belt Trusses & Braced Core

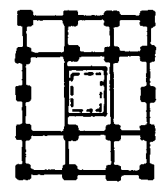
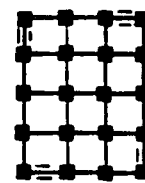
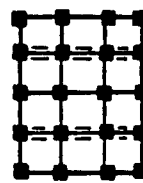
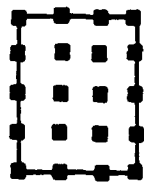
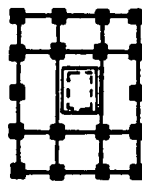

Fig. 7: Frame Systems

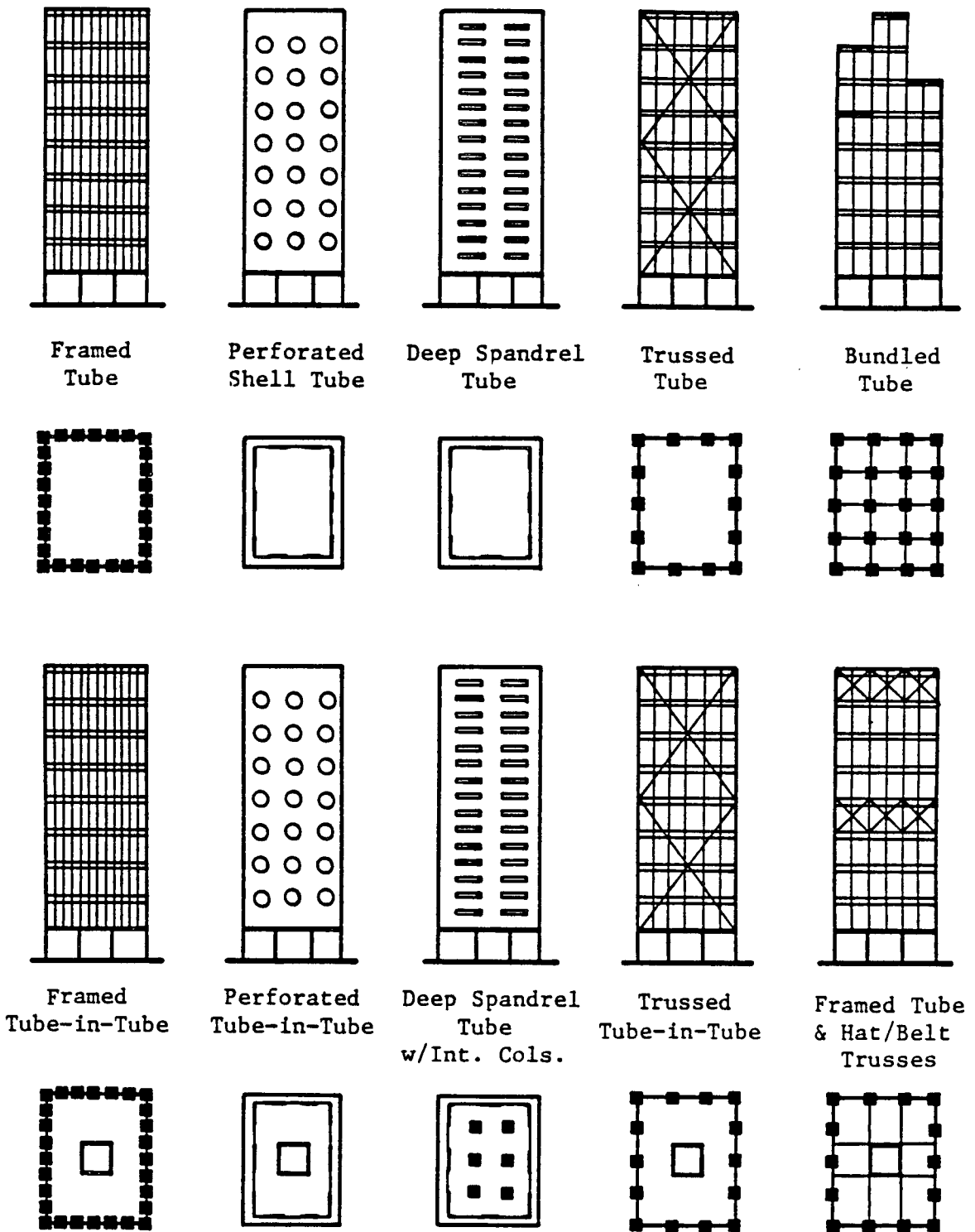

Fig. 8: Tube System

442.3

Building
Name

Structural^a

3

	Framing	Bracing	Floor	Configuration
Penzoil Place	Frame 58	12120	31	00000
MLC Centre	Tube 85	00000	31	00000
Park Towers	Wall 11	00000	21	00000
Collins Place	Tube 86	12120	31	00000
BHP House	Tube 83	????0	32	00000
USS Building	Frame 60	????0	??	0000?
Chase Manhattan	Frame 55	?????	??	?????

^aSee Table 12

Fig. 9: Sample Classification Chart

442.3

Single Diagonal
Bracing

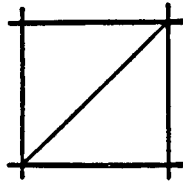

Vertical
K-Bracing

Double Diagonal
Bracing

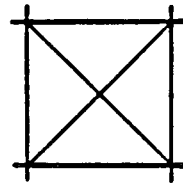

Knee
Bracing

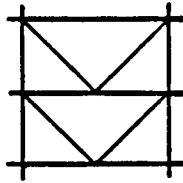

Horizontal
K-Bracing

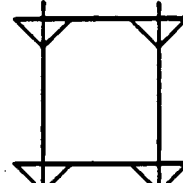

Lattice
Bracing

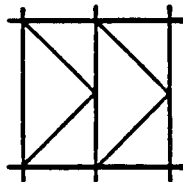

Eccentric
K-Bracing

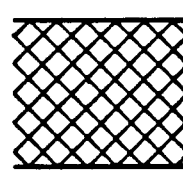

Eccentric
Diagonal Bracing

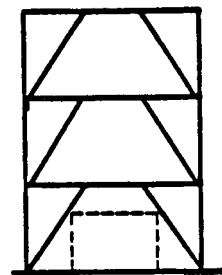

(a)

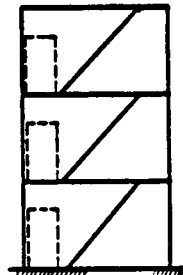

(b)

Fig. 10: Bracing Types [Council, Committee 3, 1980]

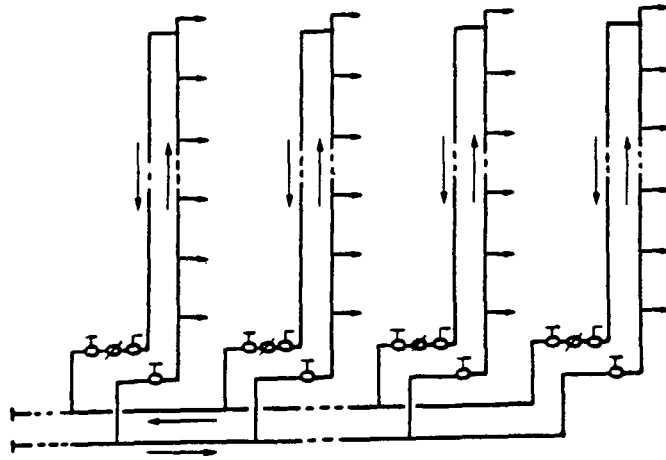

UPFEED SYSTEM
(Heater located at bottom of system)

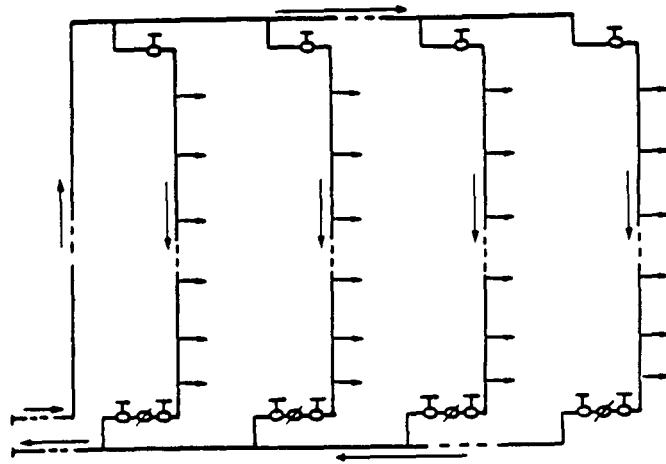

DOWNFEED SYSTEM
(Heater located at bottom of system)

Fig. 11: Plumbing Systems

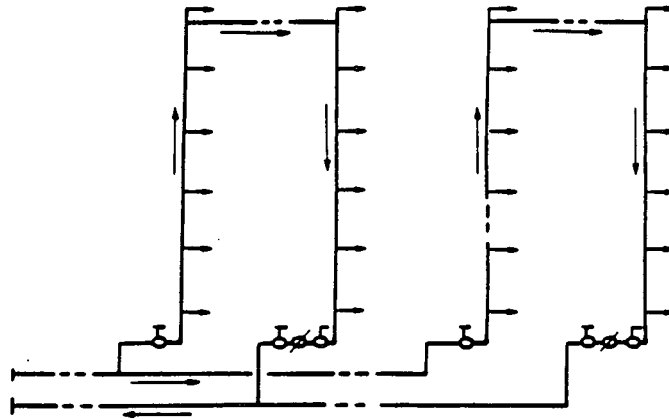

COMBINATION UPFEED AND DOWFEED SYSTEM
(Heater located at bottom of system)

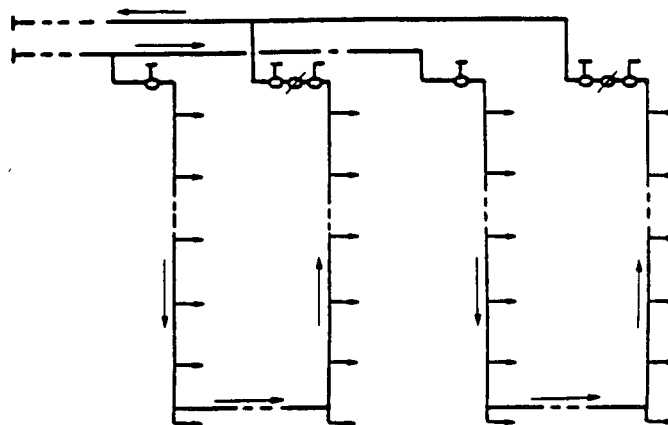

COMBINATION DOWNFEED AND UPFEED SYSTEM
(Heater located at top of system)

Fig. 11 (continued): Plumbing Systems

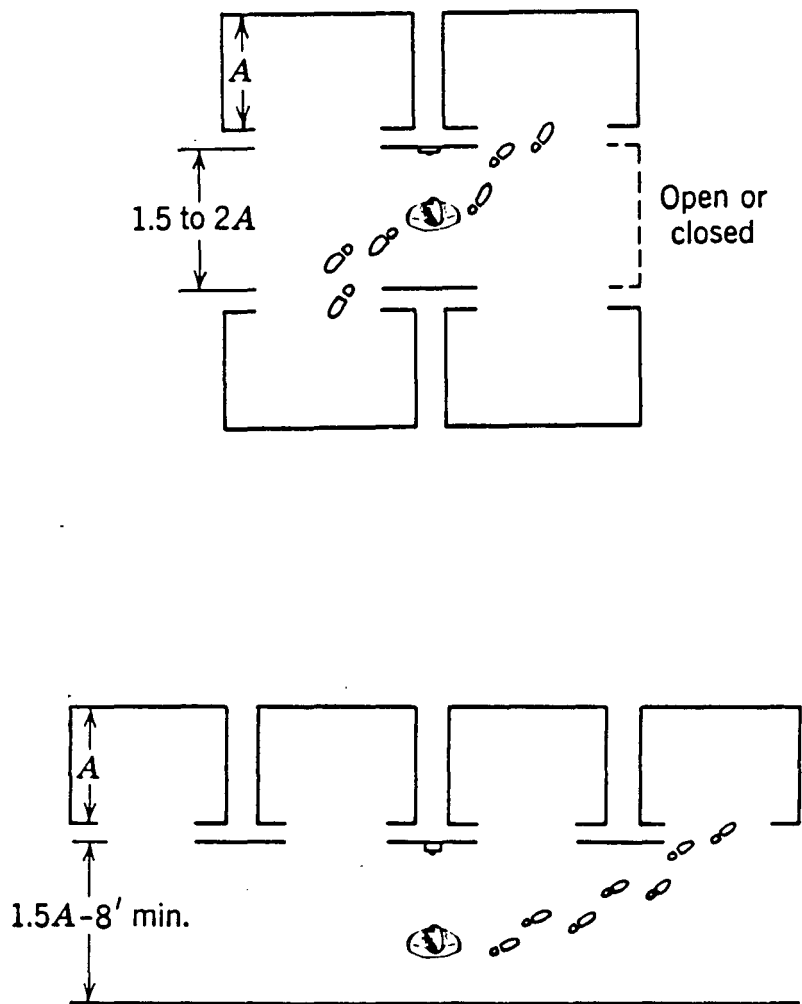

Fig. 12: Four-Car Arrangement
 [Courtesy: Otis Elevator Company]

442.3

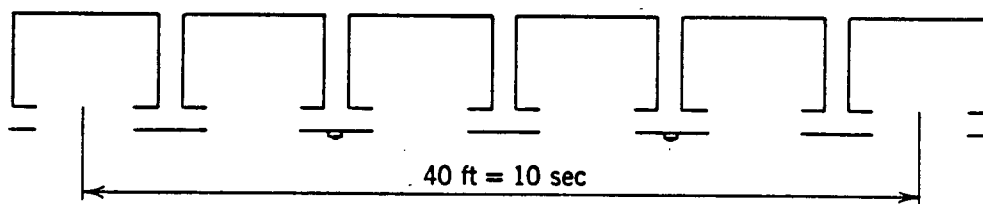

Fig. 13: Unacceptable Six-car Arrangement
[Courtesy: Otis Elevator Company]

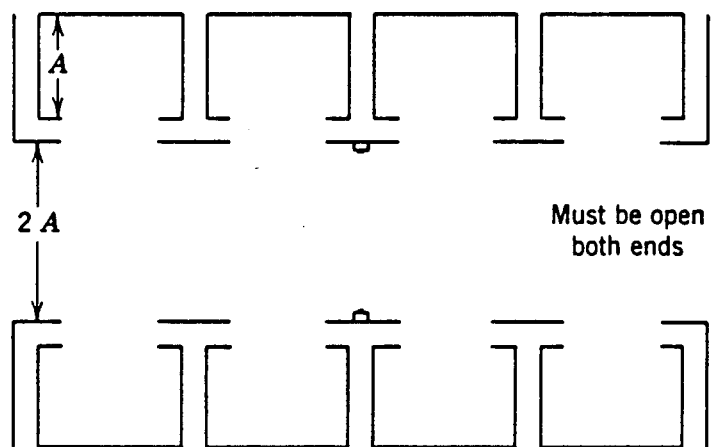

Fig. 14: Eight-car Arrangement
[Courtesy: Otis Elevator Company]

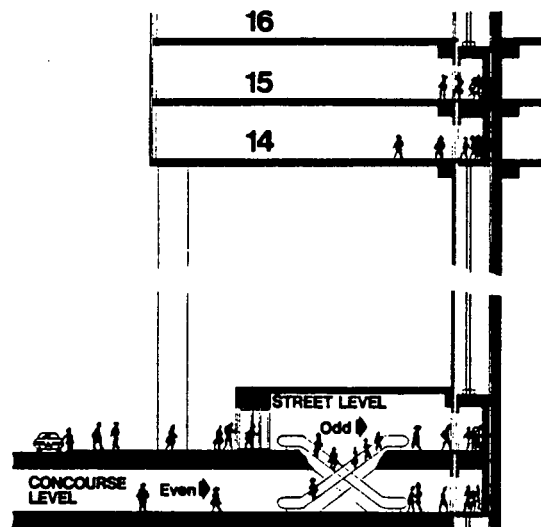

Fig. 15: Double-Deck Elevator Concept
[Courtesy: Otis Elevator Company]

442.3

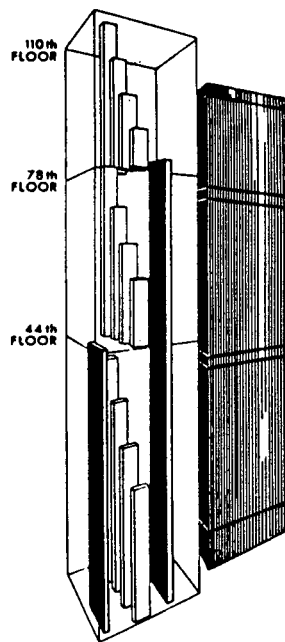
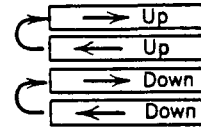
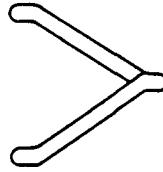
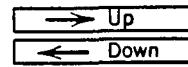
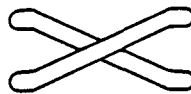

Fig. 16: Sky Lobby Concept [Courtesy: Otis Elevator Company]

Parallel



Criss-cross



Parallel separated

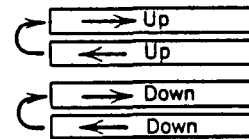
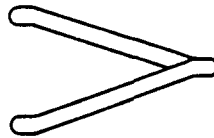

Criss-cross separated

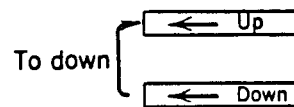
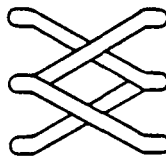

Multiple parallel

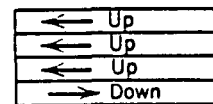
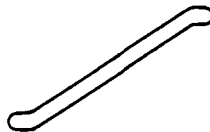

Fig. 17: Escalator or Moving Ramp Arrangements

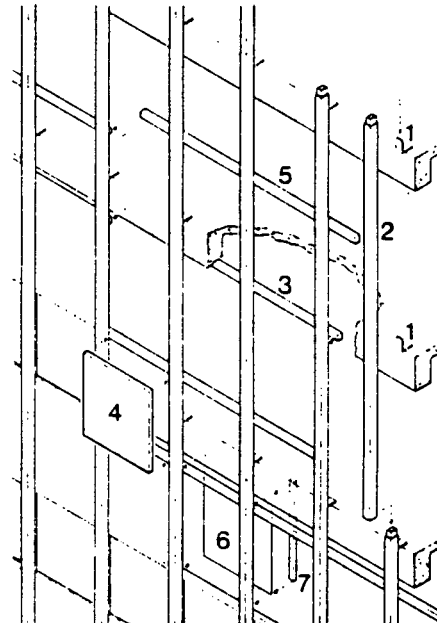

Fig. 18: Stick Systems -- Schematic of Typical Version
[Courtesy: Architectural Aluminum Manufacturers Association]

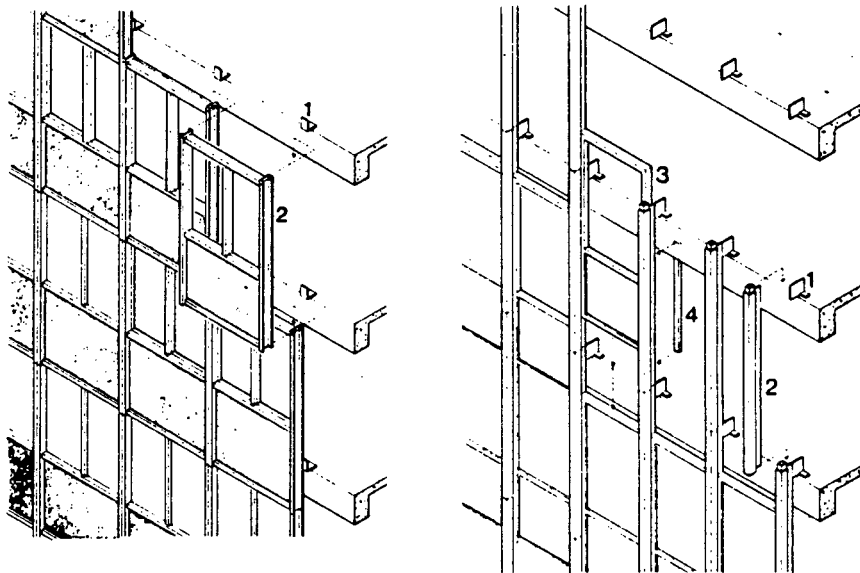

Fig. 19: Unit Systems [Courtesy: Architectural Aluminum Manufacturers Association]

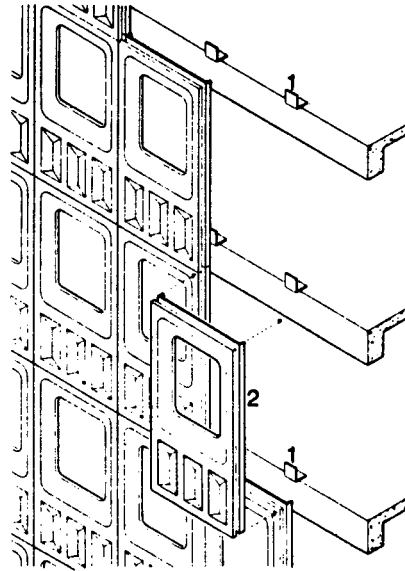

Fig. 20: Unit-and-Mullion System
[Courtesy: Architectural Aluminum
Manufacturers Association]

442.3

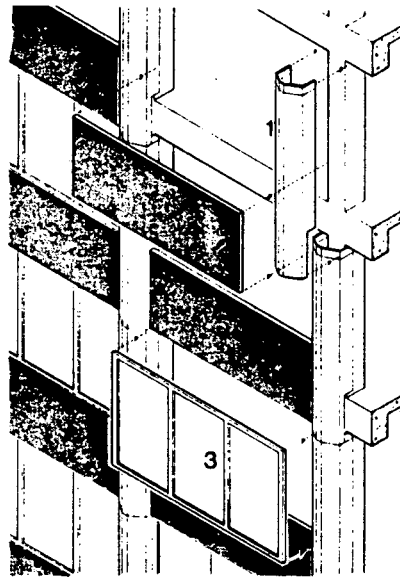

Fig. 21: Panel System [Courtesy: Architectural Aluminum Manufacturers Association]



Fig. 22: Column Cover and Spandrel System
[Courtesy: Architectural Aluminum
Manufacturers Association]

REFERENCES/BIBLIOGRAPHY

ASHRAE, 1976

ASHRAE HANDBOOK & PRODUCT DIRECTORY, American Society of Heating, Refrigerating and Air Conditioning Engineers, Inc., New York.

ATC, 1978

TENTATIVE PROVISIONS FOR THE DEVELOPMENT OF SEISMIC REGULATIONS FOR BUILDINGS, Applied Technology Council, Washington D.C..

Abdallah, N., 1973

THE M.L.C. CENTRE, Planning and Design of Tall Buildings, (Proceedings of Conference held in Sydney, Australia, August 13-17), Lehigh University, Bethlehem, pp. 316-331.

Adler, R. R., 1970

VERTICAL TRANSPORTATION FOR BUILDINGS, American Elsevier Publishing Co., Inc., New York.

Bandel, H., 1973

STRUCTURAL SYSTEMS FOR VERY TALL BUILDINGS, Planning and Design of Tall Buildings, (Proceedings of Conference held at Lehigh University, August, 1972), Vol. Ia, ASCE, New York, pp. 627-631.

Beedle, L. S., Ed., 1980

TALL BUILDING SYSTEMS IDENTIFIED, The Times, Vol. 11, No. 2, p. 2.

Beedle, L. S., Driscoll, G. C., Aydinoglu, N., and Anderson, B., 1980

HIGH-RISE BUILDING DATA BASE, Fritz Laboratory Report No. 442.2, Lehigh University, Bethlehem.

British Steel Corporation, 1972
FRAMES FOR TALL BUILDINGS, Building
With Steel, Volume 12, pp. 14-18,
November.

Callender, J. H., Ed., 1974
TIME-SAVER STANDARDS FOR
ARCHITECTURAL DESIGN DATA,
Fifth Edition, McGraw-Hill
Book Company, New York.

Christiansen, J., 1973
CAST IN PLACE REINFORCED CONCRETE
SYSTEMS, Planning and Design of Tall
Buildings, (Proceedings of Conference
held at Lehigh University, August,
1972), Vol. Ia, ASCE, New York,
pp. 437-452.

Colaco, J. P. and Banavalkar, P. V., 1975
STRUCTURAL CONCEPTS FOR MID-RISE
STRUCTURES, Pan Pacific Tall
Buildings Conference Proceedings,
(Conference held in Honolulu,
Hawaii, January), University of
Hawaii, pp. 136-150.

Colaco, J. P. and Banavalkar, P. V., 1974
PENZOIL PLACE - A NEW SLANT IN
STRUCTURAL SYSTEMS, Proceedings
of the Regional Conference on Tall
Buildings, (Conference held in
Bangkok, Thailand, January 23-25),
Asian Institute of Technology,
Bangkok, pp. 17-32.

Coull, A. and Subedi, N. K., 1971
FRAMED TUBE STRUCTURE FOR HIGH-
RISE BUILDINGS, Journal of the
Structural Division, ASCE,
Vol. 98, No. ST-8, pp. 2097-
2105, August.

Council on Tall Buildings, 1978-1981
PLANNING AND DESIGN OF TALL BUILDINGS,
A Monograph, 5 volumes, ASCE, New
York.

Council on Tall Buildings, Committee 2A, 1980
VERTICAL AND HORIZONTAL TRANSPORTATION,
Chapter SC-4, Volume SC of Monograph
on Planning and Design of Tall
Buildings, ASCE, New York.

Council on Tall Buildings, Committee 2B, 1980
MECHANICAL AND SERVICE SYSTEMS,
Chapter SC-2, Volume SC of Monograph on
Planning and Design of Tall Buildings,
ASCE, New York.

Council on Tall Buildings, Committee 3, 1980
STRUCTURAL SYSTEMS, Chapter SC-1,
Volume SC of Monograph on Planning and
Design of Tall Buildings, ASCE, New
York.

Council on Tall Buildings, Committee 2A, 1980
CLADDING, Chapter SC-5, Volume SC of
Monograph on Planning and Design of
Tall Buildings, ASCE, New York.

Council on Tall Buildings, Committee 2B, 1980
PARTITIONS, WALLS, AND CEILINGS, Chapter
SC-6, Volume SC of Monograph on Planning
and Design of Tall Buildings, ASCE.
New York.

Council on Tall Buildings, Committee 21A, 1978
CONCRETE FRAMING SYSTEMS FOR TALL BUILDINGS,
Chapter CB-3, Volume CB of Monograph on
Planning and Design of Tall Buildings,
ASCE, New York.

Dowrick, D. J., 1977
EARTHQUAKE RESISTANT DESIGN, John
Wiley & Sons, Inc., New York.

Drosdov, P. F. and Lishak, V. I., 1978
SPATIAL RIGIDITY & STABILITY OF TALL
BUILDINGS OF DIFFERENT STRUCTURAL SCHEMES,
Prefabricated Multi-Storey Buildings,
(Proceedings of Conference held in
Moscow, October 1976), Central Research
and Design Institute for Dwellings,
Moscow, pp. 27-35.

- Engel, H., 1967
STRUCTURE SYSTEMS, Praeger Publishers,
New York.
- Fleming, J. F., 1974
LATERAL TRUSS SYSTEMS IN HIGH-
RISE BUILDINGS, Proceedings of
the Regional Conference on Tall
Buildings, (Conference held in
Bangkok, Thailand, January 23-25),
Asian Institute of Technology,
Bangkok, pp. 33-48.
- Fowler, J. R., 1973
B.H.P. HOUSE, MELBOURNE, Planning and
Design of Tall Buildings, (Proceedings
of Conference held in Sydney, Australia,
August 13-17), Lehigh University,
Bethlehem, pp. 363-377.
- Garnett, M. W., 1973
A.M.P. CENTRE, SYDNEY, Planning and
Design of Tall Buildings (Proceedings
of Conference held in Sydney, Australia,
August 13-17), Lehigh University,
Bethlehem, pp. 394-409.
- Handler, A. B., 1970
SYSTEMS APPROACH TO ARCHITECTURE,
American Elsevier Publishing Co., Inc.,
New York.
- Hisatoku, T. and Nishikawa, F., 1973
MIXED AND COMPOSITE CONCRETE AND STEEL
SYSTEMS, Planning and Design of Tall
Buildings, (Proceedings of Conference
held at Lehigh University, August,
1972), Vol. Ia, ASCE, New York,
pp. 501-514.

Iyengar, S. H., 1973

STRUCTURAL SYSTEM FOR TWO ULTRA HIGH-RISE STRUCTURES, Planning and Design of Tall Buildings, (Proceedings of Conference held in Sydney, Australia, August 13-17), Lehigh University, Bethlehem, pp. 528-543.

Iyengar, S. H., 1980

SYSTEMS CRITERIA FOR MIXED STEEL-CONCRETE SYSTEMS, Developments in Composite and Mixed Construction, (Proceedings of the USA-Japan Seminar on Composite Structures and Mixed Structure Systems, held in Tokyo, Japan, January 12-14, 1978), Gihado Shuppan Company, Tokyo, pp. 283-307.

Iyengar, S. H. and Amin, N. R., 1976

STEEL-CONCRETE COMPOSITE SYSTEMS FOR TALL BUILDINGS, Proceedings of the Regional Conference on Tall Buildings, (Conference held in Hong Kong, September), Shum Shing Printing Company, Hong Kong, pp. 5-25.

Joint Committee on Tall Buildings, L. S. Beedle and L. W. Lu, Eds., 1973

PLANNING AND DESIGN OF TALL BUILDINGS, (Proceedings of ASCE-IABSE International Conference held at Lehigh University, August, 1972), ASCE, New York, (5 volumes).

Kato, B. and Lu, L. W., Eds., 1980

DEVELOPMENTS IN COMPOSITE AND MIXED CONSTRUCTION, (Proceedings of the USA-Japan Seminar on Composite Structures and Mixed Structural Systems held in Tokyo, Japan, January 12-14, 1978), Gihado Shuppan Company, Tokyo.

Keyfitz, N., in press

POPULATION OF THE WORLD AND ITS REGIONS 1975-2030, Industrial Institute for Applied Systems Analysis, Luxenberg, Austria.

- Khan, F. R., 1967
CURRENT TRENDS IN CONCRETE HIGH-RISE
BUILDINGS, Tall Buildings, A. Coull and
B. S. Smith, Eds., Pergamon Press,
London, pp. 571-590.
- Khan, F. R., 1973
RECENT DEVELOPMENT AND FUTURE OF HIGH-
RISE BUILDINGS, National Conference on
Tall Buildings, (Proceedings of Conference
held in New Delhi, India, January), Indian
National Group of the IABSE, New Delhi,
pp. 105-128.
- Khan, F. R., 1974
NEW STRUCTURAL SYSTEMS FOR TALL BUILDINGS
AND THEIR SCALE EFFECTS ON CITIES, Tall
Buildings Planning, Design and Construction,
(Proceedings of Symposium held at Vanderbilt
University, Nashville, Tennessee, November
14-15), Civil Engineering Program, Vander-
bilt University, Nashville, pp. 99-129.
- Konig, G., 1973
CAST-IN-PLACE REINFORCED CONCRETE SYSTEMS,
Planning and Design of Tall Buildings,
(Proceedings of Conference held at Lehigh
University, August, 1972), Vol. Ia, ASCE,
New York, pp 515-536.
- Kozak, J., 1973
STRUCTURAL SYSTEMS OF TALL BUILDINGS WITH
CORE STRUCTURES, Planning and Design of
Tall Buildings, (Proceedings of Conference
held at Lehigh University, August, 1972),
Vol. Ia, ASCE, New York, pp. 537-565.
- Liauw, T. C., 1974
EVOLUTION OF NEW STRUCTURAL SYSTEMS
FOR TALL BUILDINGS, Proceedings of the
Regional Conference on Tall Buildings,
(Conference held in Bangkok, Thailand,
January, 23-25), Asian Institute of Tech-
nology, Bangkok, pp. 115-126.

Libbey, R., 1975

PACIFIC TRADE CENTER - A 30 STORY OFFICE
TOWER, Pan Pacific Tall Buildings Confer-
ence Proceedings, (Conference held in
Honolulu, Hawaii, January), University of
Hawaii, Honolulu, pp. 279-290.

Lu, L. W., 1974

STRUCTURAL SYSTEMS, Modern Engineering and
Technology Seminar 1974, Vol. IX, Building
and Architecture Session, Modern Engineering
and Technology Seminar Committee, Taipei,
Taiwan, pp. 15-46.

McMillan, C. M., 1975

AFRICAN EAGLE LIFE CENTRE - A HIGH-RISE
PRECAST LOAD BEARING FACADE. Pan Pacific
Tall Buildings Conference Proceedings,
(Conference held in Honolulu, Hawaii,
January), University of Hawaii, Honolulu,
pp. 258-266.

Miller, P. O., 1973

QUANTAS CENTRE, Planning and Design of
Tall Buildings, (Proceedings of Confer-
ence held in Sydney, Australia, August
13-17), Lehigh University, Bethlehem,
pp. 410-423.

Mikroudis, George K. and Mueller, Peter, 1983

DIGEST OF CASE STUDY OF TALL BUILDINGS DAMAGED
IN EARTHQUAKES, Fritz Laboratory Report No. 474.6,
Lehigh University, Bethlehem.

Ng, P. K., Chong, S. C., and Rahulan, G., 1974

STRUCTURAL SYSTEMS OF SOME OF THE TALL
BUILDINGS IN SINGAPORE AND KUALA LUMPUR,
Proceedings of the Regional Conference on
Tall Buildings, (Conference held in
Bangkok, Thailand, January 23-25),
Asian Institute of Technology, Bangkok,
pp. 97-114.

Peyton, J., 1973

COLLINS PLACE PROJECT, MELBOURNE, Planning and Design of Tall Buildings, (Proceedings of Conference held in Sydney, Australia August 13-17), Lehigh University, Bethlehem, pp. 347-362.

Peyton, J., 1974

FLINDERS GATE - A DEVELOPMENT OVER RAILWAYS, Proceedings, Conference on Tall Buildings, (Conference held in Kuala Lumpur, Malaysia, December 2-5), Institution of Engineers, Kuala Lumpur, pp. 9-21 - 9-26.

Peyton, J., 1974

COLLINS-WALES PROJECT - A 500-FOOT TOWER IN SIMPLE HYBRID CONSTRUCTION, Proceedings, Conference on Tall Buildings, (Conference held in Kuala Lumpur, Malaysia, December 2-5), Institution of Engineers, Kuala Lumpur, pp. 9-52 - 9-57.

Rahulan, G., 1974

TUNAS BUILDING - STRUCTURAL DESIGN OF A SLENDER BUILDING, Proceedings, Conference on Tall Buildings, (Conference held in Kuala Lumpur, Malaysia, December 2-5), Institution of Engineers, Kuala Lumpur, pp. 9-15 - 9-20.

Ranada, B., 1975

DESIGN AND CONSTRUCTION OF THE HONOLULU MUNICIPAL BUILDING, Pan Pacific Tall Buildings Conference Proceedings (Conference held in Honolulu, Hawaii, January), University of Hawaii, Honolulu, pp. 161-174.

Ruderman, J., 1965

COMPARING THE HIGH-RISE STRUCTURAL SYSTEMS, Architecture and Engineering News, Vol. 7, pp. 74-79, September.

Rush, Richard, 1980

STRUCTURE AND CIRCUMSTANCE, Progressive Architecture, Vol. 61, No. 12, pp. 50-57, December.

Schueller, W., 1977
HIGH-RISE BUILDING STRUCTURES, Wiley-
Interscience, New York.

Smith, I. C., 1973
BANK OF NEW ZEALAND, CONCEPT AND DESIGN,
Planning and Design of Tall Buildings,
(Proceedings of Conference held in
Sydney, Australia, August 13-17),
Lehigh University, Bethlehem, pp. 424-
444.

Strakosch, G. R., 1967
VERTICAL TRANSPORTATION: ELEVATORS AND ESCALATORS,
J.Wiley and Sons, Inc., New York.

Steele, A., 1975
HIGHRISE PLUMBING DESIGN, Marimar Publishing
Company, Los Angeles.

Sun, T., 1979
MECHANICAL-STRUCTURAL INTERFACE IN BUILDING DESIGN
Journal of Structural Division, ASCE, Vol. 105,
No. 3, pp. 539-546, March.

Sung, M., 1974
A TRANSFER BOWL OF 20 STORY BLOCK,
Proceedings, Conference on Tall Buildings,
(Conference held in Kuala Lumpur, Malaysia,
December 2-5), Institution of Engineers,
Kuala Lumpur, pp. 9-68 - 9-72.

Taylor, D., 1973
PARK TOWERS, MELBOURNE, Planning and
Design of Tall Buildings, (Proceedings
of Conference held in Sydney, Australia,
August 13-17), Lehigh University,
Bethlehem, pp. 332-346.

Thompson, P., 1973

O.C.B.C. CENTER, SINGAPORE, Planning and Design of Tall Buildings, (Proceedings of Conference held in Sydney, Australia, August 13-17), Lehigh University, Bethlehem, pp. 379-389.

Wargon, A., 1973

CENTERPOINT PROJECT, SYDNEY, Planning and Design of Tall Buildings, (Proceedings of Conference held in Sydney, Australia, August 13-17), Lehigh University, Bethlehem, pp. 445-477.

Weinberg, B. E., 1962

MARINA CITY TOWERS, Civil Engineering, Vol. 32, No. 12, pp. 64-67, December.

Wells, F. R., 1974

STRUCTURAL SYSTEMS OF THREE SYDNEY HIGH-RISE BUILDINGS, Proceedings, Conference on Tall Buildings, (Conference held in Kuala Lumpur, Malaysia, December 2-5), Institution of Engineers, Kuala Lumpur, pp. 9-1 - 9-14.

Whyte, L. L., Wilson, A. G., Wilson, D., Eds., 1969

HIERARCHICAL STRUCTURES, American Elsevier Publishing Company, Inc., New York.