

1982

Final recommended action april 1982

Le-Wu Lu

Paul J. Miller

Lynn S. Beedle

Follow this and additional works at: <http://preserve.lehigh.edu/engr-civil-environmental-fritz-lab-reports>

Recommended Citation

Lu, Le-Wu; Miller, Paul J.; and Beedle, Lynn S., "Final recommended action april 1982" (1982). *Fritz Laboratory Reports*. Paper 2218. <http://preserve.lehigh.edu/engr-civil-environmental-fritz-lab-reports/2218>

This Technical Report is brought to you for free and open access by the Civil and Environmental Engineering at Lehigh Preserve. It has been accepted for inclusion in Fritz Laboratory Reports by an authorized administrator of Lehigh Preserve. For more information, please contact preserve@lehigh.edu.

AISC TALL BUILDING STUDY COMMITTEE

FINAL RECOMMENDED ACTIONS

Compiled by

Le-Wu Lu
Paul J. Miller
Lynn S. Beedle

April 1982

Fritz Engineering Laboratory
Lehigh University
Bethlehem, PA 18015

Fritz Engineering Laboratory Report No. 440.11

Table of Contents

	Page
1. Introduction	i
2. Suggestions and Recommended Action	
1.2A Type 2 Construction	1
1.2B Lamellar Tearing	2
1.2C Brittle Fracture	3
1.2D Type 2 Construction	4
1.3.5 Wind	5
1.3.5A Wind	6
1.3.5B Wind	7
1.3.5C Wind	8
1.3.6 Earthquakes and Hurricanes	9
1.5.1.3A Minor Axis Bending	10
1.5.1.3B End Restraint and Initial Column Crookedness	12
1.5.1.4 Lateral Buckling	14
1.6A Combined Stresses	17
1.6B Biaxial Bending	18
1.7.1 Fatigue	19
1.7 Fatigue	20
1.8A Nonlinear Analysis	21
1.8B Frame vs. Column Stability	23
1.10 Plate Girders	25
1.11.1 Effective Width	26
1.11.1 Effective Width	27
1.11A Concrete-Encased Steel Columns	28
1.11B Concrete-Filled Tubular Columns	29
1.11C Mixed Construction	30
1.11.2 Clustering of Studs	32
1.13.2 Vibration	34
1.15 End Plate Connections	35
1.15A Connections (Heavy Bolted)	37
1.15.5 Rectangular Tube Stiffening	38
1.18.2 Mixed Construction	40
1.21 Column Bases	41

Table of Contents (cont.)

		Page
2	Scope	42
2.1A	Scope, Plastic Analysis	43
2.1B	Scope, Ductile Behavior	44
2.4A	Columns	45
2.4A-1	Columns	49
2.4B	Columns	53
A	LRFD	54
B	Methods of Analysis	55
C	Dynamic Response	56
D	Drift Control	57
E	Factor of Safety for Dynamic Loading	58
F	Performance	59
G	Cladding	60
H	Nil-Ductility	61
I	Lamellar Tearing	62
J	Steel/Concrete Connections	64
K	Differential Movement of Columns	65
L	Mixed Construction	66
M	Commentary for Tall Buildings	67
N	Scope	68
O	Seismic Provisions	69
3. Appendix		
Table 1	Abbreviations	70
Table 2	Original Ballot	71

Introduction

This report compiles the full scope of the suggestions of the AISC Tall Building Study Committee with regard to the SPECIFICATION.

It is a combination of Reports 440.8 and 440.9.

Report 440.8, entitled RECOMMENDATIONS OF AISC TALL BUILDING STUDY COMMITTEE TO THE MAIN COMMITTEE, was distributed to you under date of July 10, 1981 and was subsequently sent to the Committee on Building Specifications on July 22, 1981. It contains specific recommendations to the committee: 2 specification items, 7 commentary items, and 14 additional suggestions.

Report 440.9, entitled ADDITIONAL SUGGESTIONS FOR THE SPECIFICATION, was distributed to you under date of August 10, 1981. It contained the items that needed further discussion as a result of our earlier meetings and the poll. It also included Harold Iyengar's material.

Both documents come from the earlier work of our committee (included in Report 440.6).

In this compilation we have included everything (this will save your referring back to prior documents). It also includes such comments as we could collect that had been made with regard to various provisions.

Another thing we have done is to arrange the material strictly according to specification section numbers (except for those suggestions that are not specifically correlated with Specification Sections).

Since occasionally more than one suggestion was made with regard to the same Specification Section, we have itemized these. You will find at the top of each page the item number, making use of the 1978 Specification hierarchy.

At the bottom of each page is a preliminary recommendation for the disposition of each item. These preliminary recommendations were arrived at in a meeting between Bill Milek, Le-Wu Lu, and Lynn Beedle. They are not hard and fast but will constitute a starting point for the discussion of recommendation action.

Our chairman, Fazlur Khan, expressed in November 1981 that he hoped the work of the Tall Building Study Committee could be completed as soon as practicable. Towards this end, his suggestion was that we should limit ourselves to the things that we can manage and refer to the main Committee on Building Specifications items that could be referred to an existing council or group to study the matter or to form new task groups.

Introduction (cont.)

So the focus of the April 16th meeting will be:

1. Make specific and complete recommendations to the main committee where possible.
2. Incomplete items or simply suggestions should be either developed quickly as specific items or should be referred to the Committee on Building Specifications.

This latter group can be looked at from the standpoint of two possible actions by CBS, and the committee recommendation should be specific when transmitted. The two courses of action are:

- a. Refer to CBS with a suggestion that the problem be referred to an existing group (Welding Research Council, Research Council on Structural Connections, Structural Stability Research Council, or Council on Tall Buildings and Urban Habitat).
- b. Refer to CBS to form a new study committee.

Item 1.2A (Commentary)

SECTION 1.2 TYPES OF CONSTRUCTION

In order that adequate instructions can be issued to the shop and erection forces, the basic assumptions underlying the design must be thoroughly understood by all concerned. As heretofore, these assumptions are classified under three separate but generally recognized types of construction.

For better clarity, the provisions covering tier buildings of Type 2 construction designed for wind loading were reworded in the 1969 Specification, but without change in intent. Justification for these provisions has been discussed by Disque¹ and others.

Suggested Addition to Commentary, (McGuire, Iffland, Beedle 29Aug79)

The use of Type 2 construction is a simple way of treating a complicated problem. When stiffness under lateral load is a possible limiting condition, then the analysis should be based, ~~not on the simple design assumptions, but~~ on more accurate methods that account for the flexibility of the connections.

APPROVED by CBS. Incorporate in next revision of AISC Specifications.

Item 1.2B (Commentary)

SECTION 1.2 TYPES OF CONSTRUCTION

In order that adequate instructions can be issued to the shop and erection forces, the basic assumptions underlying the design must be thoroughly understood by all concerned. As heretofore, these assumptions are classified under three separate but generally recognized types of construction.

For better clarity, the provisions covering tier buildings of Type 2 construction designed for wind loading were reworded in the 1969 Specification, but without change in intent. Justification for these provisions has been discussed by Disque¹ and others.

Suggested Addition to Commentary, (Munse 12Sep79)

In the design of highly restrained welded connections care must be exercised to provide adequate ductility and flexibility, particularly when large welds are used and high shrinkage stresses are expected (AISC, 1973). Lamellar tearing occasionally has been found to occur when a high degree of restraint is built into a weldment that produces large strains in the through-thickness direction of rolled steel plates or shapes. In addition, the welding process and procedures should be selected so as to reduce to a minimum the susceptibility of a weldment to lamellar tearing (Council on Tall Buildings, 1979, p. 459).

wherever possible

strains

RECOMMENDED ACTION: CBS Refer the matter to RCSC

Item 1.2C (Commentary)

SECTION 1.2 TYPES OF CONSTRUCTION

In order that adequate instructions can be issued to the shop and erection forces, the basic assumptions underlying the design must be thoroughly understood by all concerned. As heretofore, these assumptions are classified under three separate but generally recognized types of construction.

For better clarity, the provisions covering tier buildings of Type 2 construction designed for wind loading were reworded in the 1969 Specification, but without change in intent. Justification for these provisions has been discussed by Disque¹ and others.

Suggested Addition to Commentary, (Munse 12Sep79)

Designers of buildings with exposed steel members should be aware of the possibility of brittle fracture in welded members subjected to tensile stresses, both during construction and after completion of the structure. Materials of increased toughness may be desirable and increased care in the selection and design of members and connections may be necessary (Council on Tall Buildings, 1979, p. 465).

Comments:

Higgins (6Oct80): This suggestion is not exclusively applicable to Type 2 Construction. It should be covered under Items (F) or (I). (See pp. 45 & 46 of 440.6)

Viest (30Oct80): While I basically like some comment to this effect, the proposed wording is too general: for example, why should we be concerned in a warm climate? Needs more work and thought.

Foreman (6Nov80): Although I agree with the recommendation, I am not sure that Section 1.2 is the best place for its inclusion. It seems to me that a better place for it would be under Connections, and would like to know what the opinion of other committee members is.

Milek (2Jan81): The basic idea is okay but should be expanded. As presented it would only raise questions, apprehension and overreaction.

RECOMMENDED ACTION: Refer the matter to CBS for a possible appointment of study committee.

Item 1.2D (Commentary)

SECTION 1.2 TYPES OF CONSTRUCTION

In order that adequate instructions can be issued to the shop and erection forces, the basic assumptions underlying the design must be thoroughly understood by all concerned. As heretofore, these assumptions are classified under three separate but generally recognized types of construction.

For better clarity, the provisions covering tier buildings of Type 2 construction designed for wind loading were reworded in the 1969 Specification, but without change in intent. Justification for these provisions has been discussed by Disque¹ and others.

Suggested Addition to Commentary, (McGuire 4Sep79):

An attempt should be made to explain the background of Type 2 construction and perhaps to set limits on its use.

Background Information: To me the definition of Type 2 construction presents a dilemma. On the one hand it is useful in that it legitimizes an old practice that has been found to yield economical, satisfactory results for many ordinary structures. On the other hand, it is patently irrational, and would seem to have little place in a modern specification that is attempting to place design on a rational basis. Further, there are no limits on its application. Presumably, Type 2 construction could be used for a building of any height and slenderness. I doubt that the intention is to permit it to be applied in the design of all modern tall buildings.

Because of its usefulness, I would not suggest the deletion of "Type 2 Construction" at this time. I am suggesting that an attempt be made to explain its background and perhaps to set limits on its use. The place for this is probably in the Commentary (McGuire, 1977).

RECOMMENDED ACTION: Refer the matter to CBS for a possible appointment of study committee.

Item 1.3.5 (Commentary)

1.3.5 Wind

Proper provision shall be made for stresses caused by wind, both during erection and after completion of the building.

Suggested Addition to Commentary, (Foreman 16Aug79):

Excessive lateral deflection of the structure due to lateral loads can cause not only damage to the architectural features of the building, but also discomfort to the occupants. Therefore, when establishing drift criteria, both factors should be considered.

The type of cladding chosen will alter the response of the structure to wind loading.

Section 5.8.3 of the Monograph, Volume SB, covers proposed criteria for human comfort (Council on Tall Buildings, 1979, pp. 391-394).

Comments:

Higgins (60Oct80): The discussion of drift on pages 353 and 354 of Vol. SB is unsuitable for inclusion in the AISC Commentary for two reasons: it is too long and it is misleadingly explicit for the cases cited and silent on far too many other everyday situations. Drift limitation must be left to the engineering judgement of the designer, familiar with the details of the structure at hand. At most, a reasonable and generally accepted single value, possibly coupled with an upper limit is the only guide that can be defended.

McGuire (22Oct80): First paragraph o.k. I question usefulness of second paragraph. Drift limitation guides need careful consideration by a task committee before inclusion. Architectural features damage - why not refer to Vol. SB rather than include?

Viest (30Oct80): First paragraph looks okay. The rest of it should be handled by reference to the appropriate volume of the Monograph.

Foreman (6Nov80): This suggestion is related to suggestions (C) and (D) (p. 20). I feel that they should be pulled together in a form that would be acceptable to all the committee members. Recommendation to the Main Committee should be made only after we arrived at some final form.

Milek (2Jan81): Is AISC proper organization to establish arbitrary performance criteria which hinges on serviceability of other materials.

RECOMMENDED ACTION: Make a recommendation to CBS for adoption.

Item 1.3.5A (Specification)

1.3.5 Wind

Proper provision shall be made for stresses caused by wind, both during erection and after completion of the building.

Suggested Addition to Specification, (Gaylord 29Aug79):

Provide more adequate information for wind load in design.

Background Information: Is the information in this section adequate? It would appear that the commentary on page 103 gives the opposite approach.

Comments:

Galambos (19Sep80): Refer to ANSI A58.1.

Foreman (6Nov80): See my comment on Commentary Item 1.3.5 (p.4).

Iffland (12Jan81): The specification and commentary is adequate and leaves the designer the option on how complicated he wants to make the problem. It is too involved to try to cover.

RECOMMENDED ACTION: Refer the matter to CBS for a possible appointment of study committee.

1.3.5 Wind

Proper provision shall be made for stresses caused by wind, both during erection and after completion of the building.

Suggested Addition to Specification, (Khan, Viest 29Aug79):

Perhaps a committee should be set up to provide a statement and assist the designer to avoid falling into a trap, since the overall behavior of the building has often not been considered by designers.

Comments:

Foreman (6Nov80): See my comment on Commentary Item 1.3.5 ~~(p.4)~~.

Iffland (12Jan81): See my comment on Item 1.3.5(A) above.

RECOMMENDED ACTION: CBS Refer the matter to CTBUH.

Item 1.3.5C (Commentary)

1.3.5 Wind

Proper provision shall be made for stresses caused by wind, both during erection and after completion of the building.

Suggested Addition to Commentary, (Popov, Galambos 29Aug79):

Continuing commentary could refer to ANSI and other such groups (Popov). Also the specific limits of usefulness should be indicated. This is hard to define for Allowable-Stress Design (Galambos).

Comments:

Foreman (6Nov80): See my comment on Commentary Item 1.3.5 ~~(p.4)~~.

Iffland (12Jan81): See my comment on Item 1.3.5(A) above.

RECOMMENDED ACTION: CBS Refer the matter to CTBUH.

Item 1.3.6 (Specification)

1.3.6 Other Forces

Structures in localities subject to earthquakes, hurricanes and other extraordinary conditions shall be designed with due regard for such conditions.

Suggested Addition to Specification, (Gaylord 29Aug79):

Add information on the fundamental period of lateral vibration (ATC-3, 1978, pp. 56, 372-374).

Comments:

Galambos (19Sep80): Is function of load code.

McGuire (22Oct80): I agree that more guidance on seismic design is desirable in principle but I suggest that this or the Main Committee set up a task group to prepare a commentary section on earthquakes. Could be an effort similar to that suggested by Khan & Viest in Item 1.3.5B (see p.6).

Munse (24Dec80): If this is added it would be desirable to expand considerably on the entire question of earthquake design (design for dynamic loads).

Iffland (12Jan81): Not proper to include in the specification.

RECOMMENDED ACTION: Refer matter to AISC Specification Ad hoc Earthquake Committee

1.5.1.3 Compression

1.5.1.3.1 On the gross section of axially loaded compression members whose cross sections meet the provisions of Sect. 1.9, when Kl/r , the largest effective slenderness ratio of any unbraced segment as defined in Sect. 1.8, is less than C_c :

$$F_a = \frac{\left[1 - \frac{(Kl/r)^2}{2C_c^2}\right] F_y}{\frac{5}{3} + \frac{3(Kl/r)}{8C_c} - \frac{(Kl/r)^3}{8C_c^3}} \quad (1.5-1)$$

where

$$C_c = \sqrt{\frac{2\pi^2 E}{F_y}}$$

1.5.1.3.2 On the gross section of axially loaded compression members, when Kl/r exceeds C_c :

$$F_a = \frac{12\pi^2 E}{23(Kl/r)^2} \quad (1.5-2)$$

Suggested Addition to Specification, (Iffland 7Sep79):

MINOR AXIS BENDING, SPECIAL SECTIONS AND STEELS

Use multiple column curves.

Background Information: The column formulas in the Specification are applicable for hot-rolled shapes of moderate size subjected to bending about the major axis. They give results ranging from overconservative to underconservative for other types of columns, for columns of different steels and for bending about the minor axis. Recommendations for solving the minor axis bending have been made (Kanchanalai, Lu, 1979) but these do not solve the problem of heavy shapes, built-up columns, special cross sections, etc.

The verification of all the categories of columns by testing vertical columns is not considered important or necessary. Computer simulation of failure loads is adequate for classification of the various column types under different axis bending. The multiple column curves could be based on either the tangent modulus load or on the maximum strength. The latter procedure is recommended.

Comments:

Higgins (6Oct80): Multiple column curves based upon statistical analysis of the observed strength of axial-loaded, single-curvature specimens having equal end restraint (if any) express the maximum difference between the several groups. Such columns are seldom found in practice. Combined with end moments and unequal end restraints in frames, strength differences for members of a given slenderness ratio diminish; under reverse curvature their significance is doubtful.

McGuire (22Oct80): Suggest that this committee or Main Committee set up a task committee to re-evaluate the question of multiple column curves.

Foreman (6Nov80): I am not sure about the way in which this recommendation could be incorporated as part of the specifications, and would like to hear opinions of others.

Munse (24Dec80): The views of the SSRC should be obtained concerning this question.

Milek (2Jan81): Column maximum strength theory is fine; however, present state of knowledge is inadequate for its full implementation in form of multiple column curves. That is, the matrix of shapes and types of columns developed several years ago to organize the continuation of work contained more blanks than x's which indicated information in hand. At present time, the guesses that would be required to assign cross sections would not improve reliability of design but would introduce practical problems and increase complexity of design procedure. It's just not ready yet.

Iffland (12Jan81): Maybe more research is required.

RECOMMENDED ACTION: CBS Refer the matter to SSRC

1.5.1.3 Compression

1.5.1.3.1 On the gross section of axially loaded compression members whose cross sections meet the provisions of Sect. 1.9, when Kl/r , the largest effective slenderness ratio of any unbraced segment as defined in Sect. 1.8, is less than C_c :

$$F_a = \frac{\left[1 - \frac{(Kl/r)^2}{2C_c^2}\right] F_y}{\frac{5}{3} + \frac{3(Kl/r)}{8C_c} - \frac{(Kl/r)^3}{8C_c^3}} \quad (1.5-1)$$

where

$$C_c = \sqrt{\frac{2\pi^2 E}{F_y}}$$

1.5.1.3.2 On the gross section of axially loaded compression members, when Kl/r exceeds C_c :

$$F_a = \frac{12\pi^2 E}{23(Kl/r)^2} \quad (1.5-2)$$

1.5.1.3.3 On the gross section of axially loaded bracing and secondary members, when l/r exceeds 120:**

$$F_{as} = \frac{F_a \text{ [by Formula (1.5-1) or (1.5-2)]}}{1.6 - \frac{l}{200r}} \quad (1.5-3)$$

1.5.1.3.4 On the gross area of plate girder stiffeners:

$$F_a = 0.60F_y$$

1.5.1.3.5 On the web of rolled shapes at the toe of the fillet (crippling, see Sect. 1.10.10):

$$F_a = 0.75F_y$$

Suggested Addition to Specification, (Iffland 7Sep79):

END RESTRAINT AND INITIAL COLUMN CROOKEDNESS

K for braced frames (perhaps with a change in terminology) should be left in the column formulas to account for end restraint.

Background Information: Initial studies have indicated that for individual columns the effects of end restraints and initial column crookedness tend to cancel each other out (Galambos). Their influence in the column formulas can be included by use of a term in the column formulas the same way K for braced frames is presently included. The use of the concept of K for braced frames seems to give good results in accounting for end restraint. This suggestion should be subject to supporting verifications by research (the problem is currently being studied by SSRC TG 23).

Item 1.5.1.3B (cont.)

Comments:

McGuire (22Oct80): Intention is not clear.

Foreman (6Nov80): Since this suggestion requires further research and study, I feel that at this time it should not be recommended to the Main Committee for inclusion in the specification. We could, however, bring this need for further investigation to the attention of the Main Committee.

Munse (24Dec80): The research and justification for this item should be assembled for discussion.

Milek (2Jan81): Specifics of suggestion unclear. Current variable factor of safety is intended to compensate for initial crookedness in columns in range where important in pinned columns.

RECOMMENDED ACTION: CBS Refer the matter to JSBI.

Item 1.5.1.4 (Specification)

1.5.1.4 Bending

2. Compression:

- a. For members meeting the requirements of Sect. 1.9.1.2, having an axis of symmetry in, and loaded in, the plane of their web, and compression on extreme fibers of channels bent about their major axis:

The larger value computed by Formulas (1.5-6a) or (1.5-6b) and (1.5-7), as applicable* (unless a higher value can be justified on the basis of a more precise analysis**), but not more than $0.60F_y$.†

$$\text{When } \sqrt{\frac{102 \times 10^3 C_b}{F_y}} \leq \frac{l}{r_T} \leq \sqrt{\frac{510 \times 10^3 C_b}{F_y}}$$

$$F_b = \left[\frac{2}{3} - \frac{F_y (l/r_T)^2}{1530 \times 10^3 C_b} \right] F_y \quad (1.5-6a)$$

$$\text{When } l/r_T \geq \sqrt{\frac{510 \times 10^3 C_b}{F_y}}$$

$$F_b = \frac{170 \times 10^3 C_b}{(l/r_T)^2} \quad (1.5-6b)$$

Or, when the compression flange is solid and approximately rectangular in cross section and its area is not less than that of the tension flange:

$$F_b = \frac{12 \times 10^3 C_b}{l d / A_f} \quad (1.5-7)$$

Suggested Addition to Specification, (McGuire 4Sep79):

Consideration should be given to a lateral buckling provision such as that appearing in the Australian Code, AS 1250 (Standards Association of Australia, 1975).

Background Information: Section 5.4.3 of AS 1250 (see p. 13) is appealing in its approach, in that it gives one a mechanism for using an elastic flexural-torsional buckling solution in design if one chooses to do so. For those who do not so choose, a simple formula for F_{ob} is also given in the Specification (not enclosed). I would think that, in most cases, the simple formula would be used. But for many of the more complicated loading and boundary conditions that often arise, a designer could find and use a corresponding elastic solution for F_{ob} .

I haven't made a systematic comparison of the numerical results to be obtained under AISC and AS 1250. In one example I found similar result (see p. 14). If it is decided to pursue this suggestion, I would recommend that a small research project be set up in which a Master's student could make such a systematic comparison. If the outcome of the study is that the Australian formulas yield reasonable results in standard cases, then serious consideration should be given to incorporating them in the AISC Specification.

Item 1.5.1.4 (cont.)

AS 1250—1975

5.4.3 Other Sections. The maximum calculated stress due to bending in a beam not otherwise covered by Rules 5.4.1 and 5.4.2 shall not exceed the maximum permissible stress F_b , determined by formula 5.4.3(1) or 5.4.3(2), as appropriate:

Where F_{ob} is equal or less than F_Y —

$$F_b = \left[0.55 - 0.10 \frac{F_{ob}}{F_Y} \right] F_{ob} \dots \dots \dots 5.4.3(1)$$

Where F_{ob} is equal to or greater than F_Y —

$$F_b = \left[0.95 - 0.50 \sqrt{\left(\frac{F_Y}{F_{ob}} \right)} \right] F_Y \dots \dots \dots 5.4.3(2)$$

In formulas 5.4.3(1) and 5.4.3(2) above, the maximum stress F_{ob} in the beam at elastic buckling, shall be calculated in accordance with Rule 5.5 or by an elastic flexural-torsional buckling analysis.

Comments:

McGuire (22Oct80): Perhaps I should stress that the recommended change appeals to me because of its versatility and not because it represents any improvement over the present AISC Spec in its application to simple situations.

Foreman (6Nov80): Since this suggestion requires further research and study, I feel that at this time it should not be recommended to the Main Committee for inclusion in the specification. We could, however, bring this need for further investigation to the attention of the Main Committee.

Munse(24Dec80): This needs to be discussed thoroughly by the committee.

RECOMMENDED ACTION: CBS Refer the matter to SSRG.

ALLOWABLE STRESS vs LOAD 250 UB 37 SECTION $F_y = 250$ MPA

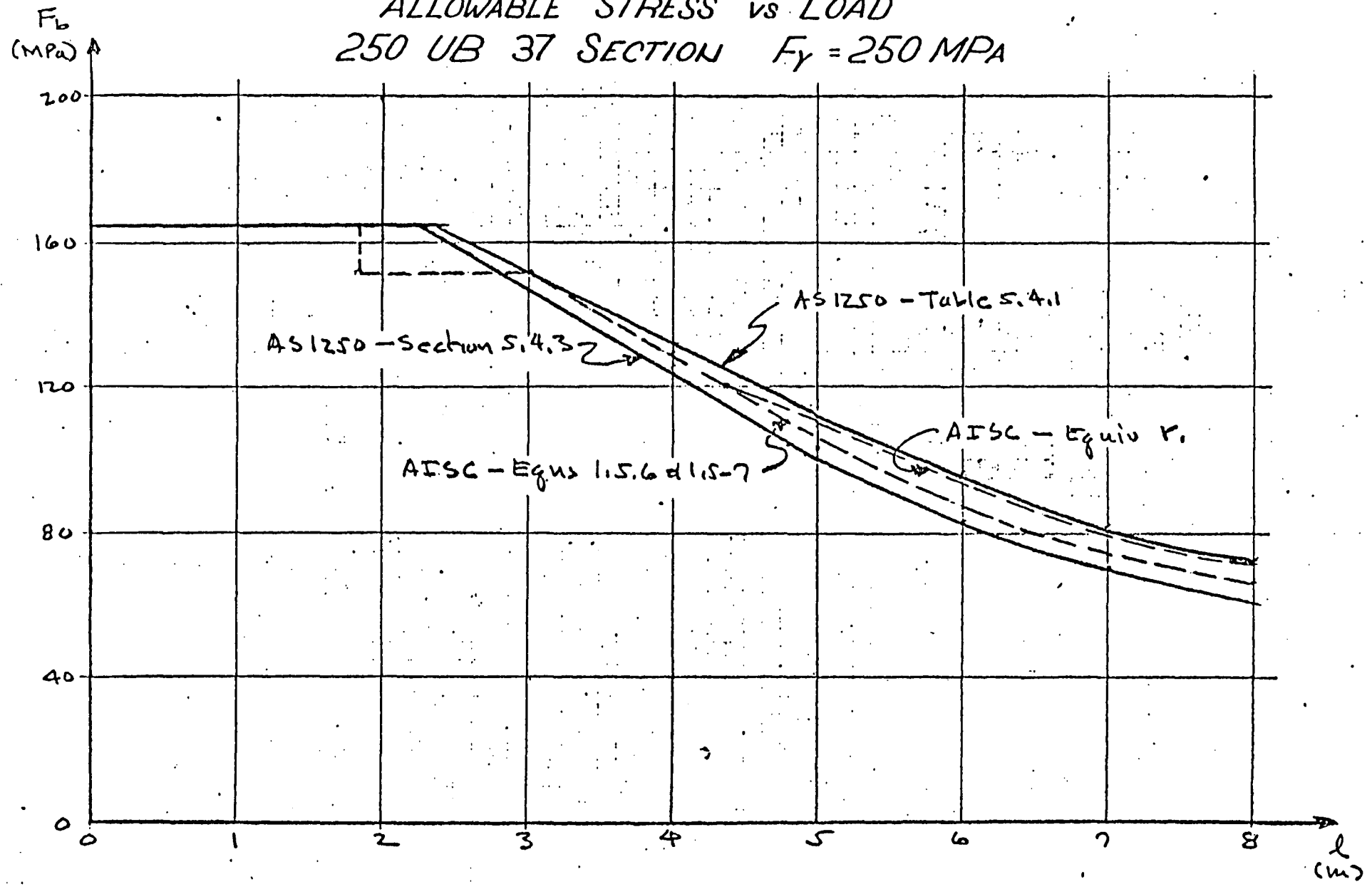

SECTION 1.6 COMBINED STRESSES

1.6.1 Axial Compression and Bending

Members subjected to both axial compression and bending stresses shall be proportioned to satisfy the following requirements:

$$\frac{f_a}{F_a} + \frac{C_{mx}f_{bx}}{\left(1 - \frac{f_a}{F'_{ex}}\right) F_{bx}} + \frac{C_{my}f_{by}}{\left(1 - \frac{f_a}{F'_{ey}}\right) F_{by}} \leq 1.0 \quad (1.6-1a)$$

$$\frac{f_a}{0.60F_y} + \frac{f_{bx}}{F_{bx}} + \frac{f_{by}}{F_{by}} \leq 1.0 \quad (1.6-1b)$$

When $f_a/F_a \leq 0.15$, Formula (1.6-2) may be used in lieu of Formulas (1.6-1a) and (1.6-1b):

$$\frac{f_a}{F_a} + \frac{f_{bx}}{F_{bx}} + \frac{f_{by}}{F_{by}} \leq 1.0 \quad (1.6-2)$$

In Formulas (1.6-1a), (1.6-1b), and (1.6-2), the subscripts x and y , combined with subscripts b , m , and e , indicate the axis of bending about which a particular stress or design property applies, and

Suggested Addition to Specification, (McGuire 4Sep79):

Add an exclusion such as the following either to the Commentary or to the definition of F_b on page 25: "Equations 1.5-6a, 1.5-6b, 1.5-7 need not be applied in determining F_{bx} and F_{by} for use in Equation 1.6-1b."

Background Information: In applying Equation 1.6-1b, is it intended that the lateral buckling equations (1.5-6a, 1.5-6b, 1.5-7) be applied in calculating F_{bx} or F_{by} ? If so, why should it be since 1.6-1b is ostensibly a check on maximum stress at a cross section and not a stability check (see Commentary page 116)? If there is a reason for using the lateral buckling formulas in Equation 1.6-1b it should be presented in the Commentary.

(Comment by Lu 7Jul81): After the above statement about Equation 1.6-1b, an explanation should be added concerning what F_{bx} and F_{by} to use.

RECOMMENDED ACTION: CBS Refer the matter to SSRC.

SECTION 1.6 COMBINED STRESSES

1.6.1 Axial Compression and Bending

Members subjected to both axial compression and bending stresses shall be proportioned to satisfy the following requirements:

$$\frac{f_a}{F_a} + \frac{C_{mx}f_{bx}}{\left(1 - \frac{f_a}{F'_{ex}}\right) F_{bx}} + \frac{C_{my}f_{by}}{\left(1 - \frac{f_a}{F'_{ey}}\right) F_{by}} \leq 1.0 \quad (1.6-1a)$$

$$\frac{f_a}{0.60F_y} + \frac{f_{bx}}{F_{bx}} + \frac{f_{by}}{F_{by}} \leq 1.0 \quad (1.6-1b)$$

When $f_a/F_a \leq 0.15$, Formula (1.6-2) may be used in lieu of Formulas (1.6-1a) and (1.6-1b):

$$\frac{f_a}{F_a} + \frac{f_{bx}}{F_{bx}} + \frac{f_{by}}{F_{by}} \leq 1.0 \quad (1.6-2)$$

In Formulas (1.6-1a), (1.6-1b), and (1.6-2), the subscripts x and y, combined with subscripts b, m, and e, indicate the axis of bending about which a particular stress or design property applies, and

Suggested Addition to Specification, (Iffland 7Sep79):

BIAXIAL BENDING

The Specification should either utilize non-linear biaxial bending formulas directly or permit their use by appropriate reference to additional details given in the Commentary.

Background Information: The column formulas given in the Specification could be overconservative for columns subjected to biaxial bending. Non-linear column formulas have been developed (Chen) that eliminate this overconservativeness.

Comments:

McGuire (22Oct80): Parallel's Driscoll's suggestions on 2.4. Should be considered by the same task committee.

Foreman (6Nov80): I feel that the suggestion in this section needs to be clarified and presented in a way in which it could be incorporated in the specification.

Munse (24Dec80): How much more complexity will this add to the specification? It needs to be discussed in detail.

Iffland (12Jan81): Equations should be permitted by commentary and not included in the specifications.

RECOMMENDED ACTION: CBS Refer the matter to SSRC (TG-3).

SECTION 1.7 MEMBERS AND CONNECTIONS SUBJECT TO
REPEATED VARIATION OF STRESS (FATIGUE)

1.7.1 General

Fatigue, as used in this Specification, is defined as the damage that may result in fracture after a sufficient number of fluctuations of stress. Stress range is defined as the magnitude of these fluctuations. In the case of a stress reversal, stress range shall be computed as the numerical sum of maximum repeated tensile and compressive stresses or the sum of maximum shearing stresses of opposite direction at a given point, resulting from differing arrangements of live load.

Few members or connections in conventional buildings need to be designed for fatigue, since most load changes in such structures occur only a small number of times or produce only minor stress fluctuations. The occurrence of full design wind or earthquake loads is too infrequent to warrant consideration in fatigue design. However, crane runways and supporting structures for machinery and equipment are ~~often~~ subject to fatigue loading conditions.

Suggested Specification Change, (Munse 12Sep79)

Replace Specification Section 1.7.1 - Paragraph 2 - Line 3 with the following:

The occurrences of full design wind, thermal or earthquake loadings are rare and generally need not be considered in fatigue design.

RECOMMENDED ACTION: Appoint Task Group on Fatigue.

SECTION 1.7 MEMBERS AND CONNECTIONS SUBJECT TO
REPEATED VARIATION OF STRESS (FATIGUE)

Because most members in building frames are not subject to a large enough number of cycles of full design stress application to require design for fatigue, the provisions covering such designs have been placed in Appendix B.

When fatigue is a design consideration, its severity is most significantly affected by the number of load applications, the magnitude of the stress range, and the severity of the stress concentrations associated with the particular details. These factors are not encountered in normal building designs; however, when encountered and when fatigue is of concern, all provisions of Appendix B must be satisfied.

Members or connections subject to less than 20,000 cycles of loading will not involve a fatigue condition, except in the case of repeated loading involving large ranges of stress. For such conditions, the admissible range of stress can conservatively be taken as $1\frac{1}{2}$ times the applicable value given in Table B3 for Loading Condition 1.

Suggested Commentary Change, (Munse 12Sep79)

Replace Commentary Section 1.7 - Paragraph 3 with the following:

Members or connections subject to less than 20,000 cycles of loading will not involve a fatigue condition, except in the case of repeated loadings involving large ranges of stress. In general, for such conditions, the admissible range of stress can conservatively be taken as $1\frac{1}{2}$ times the applicable value given in Table B3 for loading condition 1. However, under severe earthquake loadings special alternating plasticity consideration may be necessary. In addition, connections and details subjected to alternating plasticity must be scrutinized [also] with regard to the possibility of brittle fracture.

If relatively high stress ranges can be expected to occur frequently in details of low fatigue resistance as a result of wind loading and other climatic conditions, consideration should be given in design to the magnitudes of the stress ranges and the loading history expected during the projected life of the structure. In particular, the fastenings for building cladding should be examined for such loadings (Council on Tall Buildings, 1979, pp. 466-467, 471, 476).

RECOMMENDED ACTION: Appoint Task Group on Fatigue.

SECTION 1.8 STABILITY AND SLENDERNESS RATIOS

1.8.1 General

General stability shall be provided for the structure as a whole and for each compression element. Design consideration should be given to significant load effects resulting from the deflected shape of the structure or of individual elements of the lateral load resisting system, including the effects on beams, columns, bracing, connections, and shear walls.

In determining the slenderness ratio of an axially loaded compression member, except as provided in Sect. 1.5.1.3.3, the length shall be taken as its effective length Kl and r as the corresponding radius of gyration.

Suggested Addition to Specification, (McGuire 4Sep79):

Appoint a task committee with the general charge of looking into nonlinear computerized analysis/design methods and encouraging their development and use.

Background Information: Section 1.8.1 of the 1968 AISC Specification is the first real AISC specification reference to the specific consideration of second order effects in design. I believe that the desirability of nonlinear analyses will become increasingly apparent, both in tall buildings and in low, horizontally flexible structures, the use of which seems to be increasing. Further, I think that the design profession will become more receptive to them as computerized methods improve, become more practical, and are more widely understood.

See
next
page.

I note, incidentally, that the 1978 ECCS Recommendations for Steel Construction place somewhat more emphasis on 2nd order calculations than the AISC does. Admittedly, they are still equivocal in that they combine "2nd order verifications" with "1st order theory calculations" (see enclosed ECCS Section R1.2 and accompanying comments).

Presumably, our committee is looking at things that may be considered for inclusion in the AISC Specification several years from now. Some of the current "PA methods" are of immediate use of course. However, I think of them more as part of a trend, and not the final answer in themselves. I have in mind an AISC sponsored task committee that could promote, influence, and guide these developments in the interest of improved analysis/design methods for steel buildings.

RECOMMENDED ACTION: CBS Refer the matter to JSBI.

R 1.2 LIMIT STATES

There are two categories of limit states:

- the ultimate limit states,
- the serviceability limit states.

R 1.2.1 ULTIMATE LIMIT STATES

These limit states, which correspond to the maximum load carrying capacity, should be checked either by an elastic method of analysis or by the so called "plastic design" methods of calculation.

In both cases, the limit states can be reached due to:

- loss of static equilibrium of the structure considered as a rigid body,
 - elastic or inelastic instability,
- and, depending on whether there is an elastic or a plastic calculation, due to:
- attainment, even at a single point in the structure of a conventional level of stress. This conventional level of stress is given in different items of these recommendations as calculation values of the resistance, when the stresses are calculated in the elastic field,
 - transformation of the structure into a mechanism (plastic design).

When the stresses are calculated over the initial geometry of the structure (before loading), the verifications are called of the 1st order.

The verifications are called of the 2nd order when the calculated force resultants are nonlinear with respect to the displacement of the structure.

The verifications of the 1st order are accepted only if the possible errors can be judged as being negligible.

R 1.2.2 SERVICEABILITY LIMIT STATES

The serviceability limit states, which generally consist in deformation criteria for steel structures, are assessed by codes and/or specifications; the latter being stated to cover particular cases.

For the serviceability limit states, the calculations must always be carried out in the elastic field.

C 1.2

The following items must be completed for certain kinds of structures and for certain types of actions.

Those items should be given in particular specifications, especially in case of fatigue and dynamic actions.

C 1.2.1

In a general way, the verification calculations will be of the 1st order (it's the current practice).

The requirements concerning the buckling, the lateral buckling and the local buckling have been set up by placing the calculations in the field of the 2nd order; they lead to formulations which will be applied to verifications based on force resultants as calculated by 1st order theory.

The following items give the characteristic values of the strength for different states of stress.

The characteristic value of the strength in case of tension is or the value of the yield point guaranteed by the steel fabricator or the mean value minus two standard deviation.

It is admitted for elastic calculations under bending moments at ultimate limit state to take into account a partial yielding of the cross section (see R 3.2.4).

Item 1.8B (Specification)

SECTION 1.8 STABILITY AND SLENDERNESS RATIOS

1.8.1 General

General stability shall be provided for the structure as a whole and for each compression element. Design consideration should be given to significant load effects resulting from the deflected shape of the structure or of individual elements of the lateral load resisting system, including the effects on beams, columns, bracing, connections, and shear walls.

In determining the slenderness ratio of an axially loaded compression member, except as provided in Sect. 1.5.1.3.3, the length shall be taken as its effective length Kl and r as the corresponding radius of gyration.

Suggested Addition to Specification, (Iffland 7Sep79)FRAME STABILITY VS. COLUMN STABILITY

K , as a measure of frame instability, should be eliminated from the column formulas and the Specification should state clearly that the formulas given are for design of individual columns. The Specification would require that frames be checked for failure against instability. Procedures for checking (or designing against) instability could be discussed in the Commentary but the responsibility for how this is accomplished should be left up to the designer since most available procedures are only selectively applicable. The Factor of Safety against frame instability should be different for frames subjected to gravity loading alone versus frames subjected to both gravity loading and transverse loading.

It is suggested that the Commentary include details on at least one specific method of handling the problem of frame stability. The P-Delta method given in Chapter SB-4 of the Monograph (Council on Tall Buildings, 1979) is an acceptable procedure, easily understood by engineers, which, by adjustment of the Factor \bar{F} , it can be made conservative without being uneconomical.

Background Information: The use of the Effective Length Factor K in the column design formulas is a procedure for considering the stability of the entire frame in the design of a single column. Actually, K , assuming it is computed accurately, only considers the buckling of an equivalent axially loaded frame. In many practical cases the magnitudes of the P-Delta Forces are more important stability considerations. Several procedures have been suggested to include both of these effects into the column formula. (Lu, LeMessurier, Cheong-Siat-May). These procedures can be criticized for two important reasons:

- (1) They unduly complicate the column formula so that the possibility of misunderstanding and misuse is magnified while at the same time they are restricted to certain difficult to define classes and types of frames.
- (2) There are many other factors that could influence the stability of a structure (Birnstiel and Iffland) and the suggested procedures tacitly ignore these even though they could be critical. (e.g.: partially restrained joints, torsional failure, panel distortion).

Item 1.8B (cont.)

The SSRC in T.M. 5 has stated that, while it may not be theoretically correct, it is not logical to try to solve the frame stability problem (for any conceivable configuration of frames with or without supplementary bracing, offset columns and other special conditions) by use of a formula used to design a single column.

RECOMMENDED ACTION: CBS Refer the matter to JSBI.

SECTION 1.10 PLATE GIRDERS AND ROLLED BEAMS

1.10.1 Proportions

Plate girders, coverplated beams, and rolled or welded beams shall in general be proportioned by the moment of inertia of the gross section. No deduction shall be made for shop or field rivet or bolt holes in either flange, except that in cases where the reduction of the area of either flange by such holes, calculated in accordance with the provisions of Sect. 1.14.2, exceeds 15 percent of the gross flange area, the excess shall be deducted.

Suggested Specification Change, (McGuire 4Sep79):

Form an ad hoc task group to review the results of recent plate girder research with the objective of seeing whether it provides any basis for improved plate girder proportioning provisions.

Background Information: So far as I know, the plate girder provisions in the present AISC Specifications have been satisfactory. They do, however, rest on research that was conducted twenty years ago. A lot has been done since then. ~~In particular, I think of the work of Porter, Rokey, and Evans at Cardiff. I believe that significant work in this area has also been done in central Europe and Japan.~~

RECOMMENDED ACTION: CBS Refer the matter to SSRC.

SECTION 1.11 COMPOSITE CONSTRUCTION

1.11.1 Definition

Composite construction shall consist of steel beams or girders supporting a reinforced concrete slab,* so interconnected that the beam and slab act together to resist bending.

When the slab extends on both sides of the beam, the *effective width* of the concrete flange shall be taken as not more than $\frac{1}{4}$ the span of the beam, and its *effective projection* beyond the edge of the beam shall not be taken as more than $\frac{1}{2}$ the clear distance to the adjacent beam, nor more than 8 times the slab thickness. When the slab is present on only one side of the beam, the *effective projection* shall be taken as not more than $\frac{1}{12}$ of the beam span, nor 6 times its thickness, nor $\frac{1}{2}$ the clear distance to the adjacent beam.

Beams totally encased 2 inches or more on their sides and soffit in concrete cast integrally with the slab may be assumed to be interconnected to the concrete by natural bond, without additional anchorage, provided the top of the beam is at least $1\frac{1}{2}$ inches below the top and 2 inches above the bottom of the slab, and further provided that the encasement has adequate mesh or other reinforcing steel throughout the whole depth and across the soffit of the beam to prevent spalling of the concrete. When shear connectors are provided in accordance with Sect. 1.11.4, encasement of the beam to achieve composite action is not required.

Suggested Specification Change, (Viest 29Aug79):

EFFECTIVE WIDTH

Replace Specification Section 1.11.1 - Paragraph 1 - Lines 3-9 with the following:

The effective width of the concrete slab on each side of the beam centerline shall be taken as the least of (1) one-eighth of the beam span, center-to-center of supports, (2) one-half the distance to the centerline of the adjacent beam and (3) the distance to the edge of the slab.

APPROVED by CBS. Incorporate in next revision of AISC Specifications.

SECTION 1.11 COMPOSITE CONSTRUCTION

1.11.1 Definition

When the dimensions of a concrete slab supported on steel beams are such that the slab can effectively serve as the flange of a composite T-beam, and the concrete and steel are adequately tied together so as to act as a unit, the beam can be proportioned on the assumption of composite action.

Two cases are recognized: fully encased steel beams, which depend upon natural bond for interaction with the concrete, and those with mechanical anchorage to the slab (shear connectors), which do not have to be encased.

For composite beams with formed steel deck, studies^{56,57} have demonstrated that the total slab thickness, including ribs, can be used in determining effective slab width.

Suggested Commentary Change, (Viest 29Aug79):

EFFECTIVE WIDTH

Replace Commentary Section 1.11.1 - Paragraph 3 with the following:

The new criteria for effective width omit any limit based on slab thickness, in accord with both theoretical and experimental studies as well as current composite beam codes in other countries (Hansell et al., 1978). The same effective width rules apply to composite beams with a slab on either one side or both sides of the beam. To simplify design, effective width is based on the full span, center-to-center of supports, for both simple and continuous beams.

APPROVED by CBS. Incorporate in next revision of AISC Specifications.

SECTION 1.11 COMPOSITE CONSTRUCTION.

1.11.1 Definition

Composite construction shall consist of steel beams or girders supporting a reinforced concrete slab,* so interconnected that the beam and slab act together to resist bending. When the slab extends on both sides of the beam, the *effective width* of the concrete flange shall be taken as not more than $\frac{1}{4}$ the span of the beam, and its *effective projection* beyond the edge of the beam shall not be taken as more than $\frac{1}{2}$ the clear distance to the adjacent beam, nor more than 8 times the slab thickness. When the slab is present on only one side of the beam, the *effective projection* shall be taken as not more than $\frac{1}{12}$ of the beam span, nor 6 times its thickness, nor $\frac{1}{2}$ the clear distance to the adjacent beam.

Beams totally encased 2 inches or more on their sides and soffit in concrete cast integrally with the slab may be assumed to be interconnected to the concrete by natural bond, without additional anchorage, provided the top of the beam is at least $1\frac{1}{2}$ inches below the top and 2 inches above the bottom of the slab, and further provided that the encasement has adequate mesh or other reinforcing steel throughout the whole depth and across the soffit of the beam to prevent spalling of the concrete. When shear connectors are provided in accordance with Sect. 1.11.4, encasement of the beam to achieve composite action is not required.

Suggested Addition to Specification, Viest 29Aug79):

Insert material on Concrete-Encased Steel Columns (Council on Tall Buildings, 1979, pp. 655-671; Task Group 20, SSRC, 1979).

RECOMMENDED ACTION: CBS Refer the matter to SSRC.

SECTION 1.11 COMPOSITE CONSTRUCTION

1.11.1 Definition

Composite construction shall consist of steel beams or girders supporting a reinforced concrete slab,* so interconnected that the beam and slab act together to resist bending. When the slab extends on both sides of the beam, the *effective width* of the concrete flange shall be taken as not more than $\frac{1}{4}$ the span of the beam, and its *effective projection* beyond the edge of the beam shall not be taken as more than $\frac{1}{2}$ the clear distance to the adjacent beam, nor more than 8 times the slab thickness. When the slab is present on only one side of the beam, the *effective projection* shall be taken as not more than $\frac{1}{12}$ of the beam span, nor 6 times its thickness, nor $\frac{1}{2}$ the clear distance to the adjacent beam.

Beams totally encased 2 inches or more on their sides and soffit in concrete cast integrally with the slab may be assumed to be interconnected to the concrete by natural bond, without additional anchorage, provided the top of the beam is at least $1\frac{1}{2}$ inches below the top and 2 inches above the bottom of the slab, and further provided that the encasement has adequate mesh or other reinforcing steel throughout the whole depth and across the soffit of the beam to prevent spalling of the concrete. When shear connectors are provided in accordance with Sect. 1.11.4, encasement of the beam to achieve composite action is not required.

Suggested Addition to Specification, (Viest 29Aug79):

Insert material on Concrete-Filled Tubular Columns (Council on Tall Buildings, 1979, pp. 671-680; Task Group 20, SSRC, 1979).

RECOMMENDED ACTION: CBS Refer the matter to SSRC.

I recommend that Composite Construction Section 1:11 be broadened to include all components of a composite or mixed system. Such components should include the following:

1. Composite Columns:

Task Group 20 of the Structural Stability Research Council has been working with the SSLC (Structural Specifications Liaison Committee) in the last few years to generate a composite column design in the AISC format. A paper on this subject was published in the AISC Journal, Fourth Quarter, 1979, entitled "A Specification for the Design of Steel-Concrete Composite Columns", under the sponsorship of Task Group 20. Since then, Task Group 20 has been involved in further updating and verification of the procedure. I believe the procedure is complete enough to be reviewed by an appropriate AISC Committee and included in the AISC Specification.

2. Composite Beams, Joists and Trusses:

In addition to composite beams with solid slabs, with or without ribbed decks, other forms of composite members should be recognized.

a. Composite action of steel beams with precast concrete planks or shallow hollow core units with structural concrete topping.

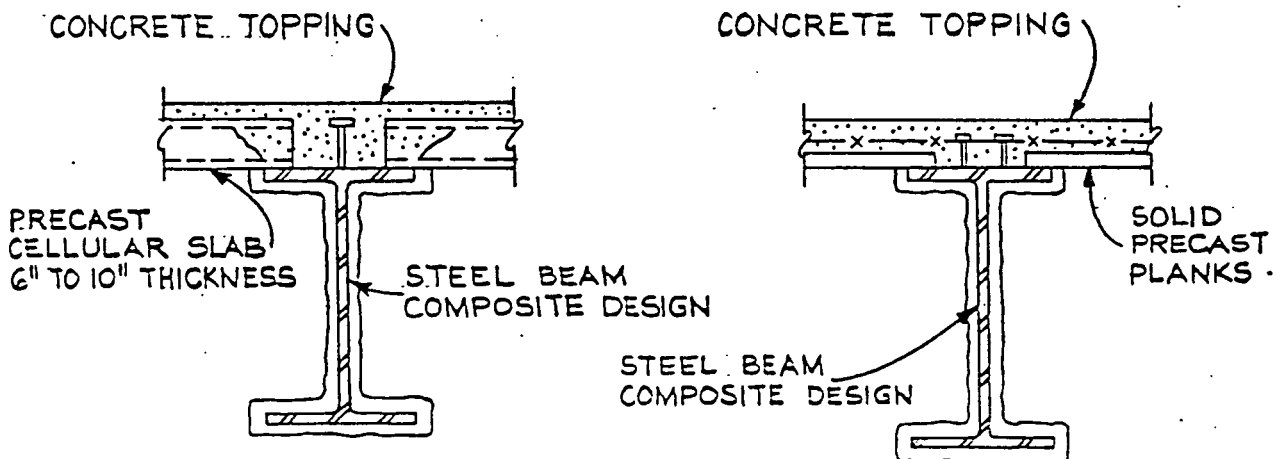

b. Composite Design of Joists and Trusses

There appears to be a significant current application of such floor framing.

c. Continuous Composite Beams

There appears to be some significant test data available to formulate a design procedure for continuous composite beams.

3. Connections between Steel and Concrete Elements:

Either in this section or in Part 4, introduce a subsection devoted to the connection between steel and reinforced concrete elements. Such connections generally include:

- a. Shear connection of steel beam to wall or concrete column by anchor plates cast in concrete.
- b. Connection between steel beam and concrete wall or column by means of a bearing detail in a pocket.
- c. Other types of mixed system connections.

Please refer to Section 5 on Connections in the SOA Report on Composite or Mixed Steel-Concrete Construction for Buildings.

RECOMMENDED ACTION:

1.11.2 Design Assumptions

1.11.2.1 Encased beams shall be proportioned to support, unassisted, all dead loads applied prior to the hardening of the concrete (unless these loads are supported temporarily on shoring) and, acting in conjunction with the slab, to support all dead and live loads applied after hardening of the concrete, without exceeding a computed bending stress of $0.66F_y$, where F_y is the yield stress of the steel beam. The bending stress produced by loads after the concrete has hardened shall be computed on the basis of the section properties of the composite section. Concrete tension stresses shall be neglected. Alternatively, the steel beam alone may be proportioned to resist, unassisted, the positive moment produced by all loads, live and dead, using a bending stress equal to $0.76F_y$, in which case temporary shoring is not required.

1.11.2.2 When shear connectors are used in accordance with Sect. 1.11.4, the composite section shall be proportioned to support all of the loads without exceeding the allowable stress prescribed in Sect. 1.5.1.4, even when the steel section is not shored during construction. In calculations involving composite sections in positive moment areas, the steel cross section is exempt from the compactness requirements of subparagraphs 2, 3, and 5 of Sect. 1.5.1.4.1.

Reinforcement parallel to the beam within the effective width of the slab, when anchored in accordance with the provisions of the applicable building code, may be included in computing the properties of composite sections, provided shear connectors are furnished in accordance with the requirements of Sect. 1.11.4. The section properties of the composite section shall be computed in accordance with the elastic theory. Concrete tension stresses shall be neglected. For stress computations, the compression area of lightweight or normal weight concrete shall be treated as an equivalent area of steel by dividing it by the modular ratio, n , for normal weight concrete of the strength specified when determining the section properties. For deflection calculations, the transformed section properties shall be based on the appropriate modular ratio, n , for the strength and weight concrete specified, where $n = E_c/E_s$.

In cases where it is not feasible or necessary to provide adequate connectors to satisfy the horizontal shear requirements for full composite action, the effective section modulus shall be determined as

$$S_{eff} = S_s + \sqrt{\frac{V'_h}{V_h}} (S_{tr} - S_s) \tag{1.11-1}$$

where

V_h and V'_h are as defined in Sect. 1.11.4.

S_s = section modulus of the steel beam referred to its bottom flange, inches³

S_{tr} = section modulus of the transformed composite section referred to its bottom flange, based upon maximum permitted effective width of concrete flange (Sect. 1.11.1), inches³

For construction without temporary shoring, stress in the steel section may be computed from the total dead plus live load moment and the transformed section modulus, S_{tr} , provided that the numerical value of S_{tr} so used shall not exceed

$$S_{tr} = \left(1.35 + 0.35 \frac{M_L}{M_D} \right) S_s \quad (1.11-2)^*$$

In this expression for the limiting value of S_{tr} , M_L is the moment caused by loads applied subsequent to the time when the concrete has reached 75 percent of its required strength, M_D is the moment caused by loads applied prior to this time, and S_s is the section modulus of the steel beam referred to the flange where the stress is being computed. At sections subject to positive bending moment, the stress shall be computed for the steel tension flange. At sections subject to negative bending moment, the stress shall be computed for the steel tension and compression flanges. These stresses shall not exceed the appropriate value in Sect. 1.5.1. Section 1.5.6 shall not apply to stresses in the negative moment area computed under the provisions of this paragraph.

The actual section modulus of the transformed composite section shall be used in calculating the concrete flexural compression stress and, for construction without temporary shores, this stress shall be based upon loading applied after the concrete has reached 75 percent of its required strength. The stress in the concrete shall not exceed $0.45f'_c$.

Suggested Addition to Specification, (Milek 29Aug79):

Include information on clustering of studs.

RECOMMENDED ACTION: Refer the matter to CBS for a possible appointment of study committee.

1.13.2 Vibration

Where human comfort is the criterion for limiting motion, as in the case of perceptible vibrations, the limit of tolerable amplitude is dependent on both the frequency of the vibration and the damping effect provided by components of the construction. At best, the evaluation of these criteria is highly subjective, although mathematical models⁴² do exist which may be useful. When such vibrations are caused by running machinery, they should be isolated by effective damping devices or by the use of independent foundations.

The depth of a steel beam supporting large open floor areas free of partitions or other sources of damping should not be less than $\frac{1}{20}$ of the span, in order to minimize perceptible transient vibration due to pedestrian traffic.

Suggested Addition to Commentary, (Foreman 13Sep79):

Include Amplitude-Frequency curves together with formulas for calculating both amplitude and frequency. Refer to material by Murray (1975), and Murray and Hendrick (1977).

RECOMMENDED ACTION: Refer the matter to CBS for a possible appointment of study committee.

Item 1.15 (Specification)

SECTION 1.15 CONNECTIONS

1.15.1 Minimum Connections

Connections carrying calculated stresses, except for lacing, sag bars, and girts, shall be designed to support not less than 6 kips.

1.15.2 Eccentric Connections

Axially stressed members meeting at a point shall have their gravity axes intersect at a point, if practicable; if not, provision shall be made for bending stresses due to the eccentricity.

1.15.3 Placement of Rivets, Bolts, and Welds

Except as hereinafter provided, groups of rivets, bolts, or welds at the ends of any member transmitting axial stress into that member shall have their centers of gravity on the gravity axis of the member, unless provision is made for the effect of the resulting eccentricity. Except in members subject to repeated variation in stress, as defined in Sect. 1.7, disposition of fillet welds to balance the forces about the neutral axis or axes for end connections of single angle, double angle, and similar type members is not required. Eccentricity between the gravity axes of such members and the gage lines for their riveted or bolted end connections may be neglected in statically loaded members, but should be considered in members subject to fatigue loading.

1.15.4 Unrestrained Members

Except as otherwise indicated by the designer, connections of beams, girders, or trusses shall be designed as flexible, and may ordinarily be proportioned for the reaction shears only.

Flexible beam connections shall accommodate end rotations of unrestrained (simple) beams. To accomplish this, inelastic action in the connection is permitted.

1.15.5 Restrained Members

1.15.5.1 Fasteners or welds for end connections of beams, girders, and trusses shall be designed for the combined effect of forces resulting from moment and shear induced by the rigidity of the connections.

Suggested Addition to Specification, (McGuire 4Sep79):

Appoint an ad hoc task group to investigate provisions relating to the proportioning of end plate connections in tall buildings.

Background Information: End plate connections seem to be with us more and more. They are different from T-stub hangers.

With respect to the use of end plates in tall buildings - as contrasted to their use in single story industrial frames - I think a few cautionary notes may be deduced from Dr. Krishnamurthy's discussion in the 2nd Quarter 1979 AISC Engineering Journal. He notes, for example, "For these (live and wind loads) and all other loads which would be treated as static loads in conventional analysis and design, the author's procedure is equally applicable in his opinion." Also, "Many of the proposed connections would hold the original angles virtually unchanged, within the working load levels; many would not." I don't agree that, just because we conventionally treat wind on a tall building as a static load, we can ignore the question of whether or not the bolts could loosen under fluctuating live and wind loads. Similarly, the source of any semi-rigid behavior should be identified before relatively thin end plates are sanctioned for use as moment connections in tall buildings. If the source is permanent bolt elongation, the connection could be an undesirable one. Concerns of this sort could be considered by the ad-hoc group suggested above.

RECOMMENDED ACTION: Refer the matter to CBS for a possible appointment of study committee.

Suggested Addition to Commentary, (Chen 29Aug79)

STIFFNESS OF HEAVY BOLTED CONNECTIONS

Add Section 1.15.A to the Commentary:

For a structure that might be sensitive to end rotations, the slip of bolted flange plate connections reduces their stiffness.

In contrast to the behavior of moment connections with beam flanges welded to the column, moment connections with fasteners designed for bearing exhibit a slip characteristic that results in a reduction of stiffness at loads less than the plastic limit load of the beam (Standig et al., 1976). There are three distinct segments in a typical load deflection curve (Fig.1). The deflection resulting from slip of bearing bolted moment connections may be an additional factor to be considered in the analysis of the stability of frames.

and deflection

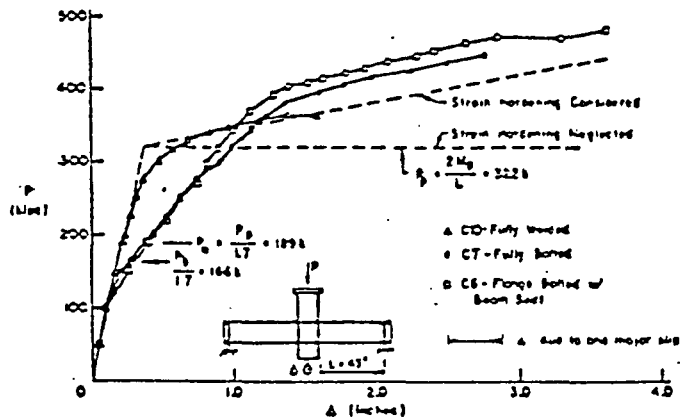

RECOMMENDED ACTION: Make a recommendation to CBS for adoption.

1.15.5 Restrained Members*

1.15.5.1 Fasteners or welds for end connections of beams, girders, and trusses shall be designed for the combined effect of forces resulting from moment and shear induced by the rigidity of the connections.

1.15.5.2 When flanges or moment connection plates for end connections of beams and girders are welded to the flange of an I- or H-shape column, a pair of column-web stiffeners having a combined cross-sectional area, A_{st} , not less than that computed from Formula (1.15-1) shall be provided whenever the calculated value of A_{st} is positive.

$$A_{st} = \frac{P_{bf} - F_{yc}t(t_b + 5k)}{F_{yst}} \quad (1.15-1)$$

where

- F_{yc} = column yield stress, kips per square inch
- F_{yst} = stiffener yield stress, kips per square inch
- k = distance between outer face of column flange and web toe of its fillet, if column is a rolled shape, or equivalent distance if column is a welded shape, inches
- P_{bf} = the computed force delivered by the flange or moment connection plate multiplied by $\frac{2}{3}$, when the computed force is due to live and dead load only, or by $\frac{4}{3}$,* when the computed force is due to live and dead load in conjunction with wind or earthquake forces, kips
- t = thickness of column web, inches
- t_b = thickness of flange or moment connection plate delivering concentrated force, inches

1.15.5.3 Notwithstanding the requirements of Sect. 1.15.5.2, a stiffener or a pair of stiffeners shall be provided opposite the compression flange when the column web depth clear of fillets, d_c , is greater than

$$\frac{4100 t^3 \sqrt{F_{yc}}}{P_{bf}} \quad (1.15-2)$$

and a pair of stiffeners shall be provided opposite the tension flange when the thickness of the column flange, t_f , is less than

$$0.4 \sqrt{\frac{P_{bf}}{F_{yc}}} \quad (1.15-3)$$

1.15.5.4 Stiffeners required by the provisions of Sects. 1.15.5.2 and 1.15.5.3 shall comply with the following criteria:

1. The width of each stiffener plus $\frac{1}{2}$ the thickness of the column web shall be not less than $\frac{1}{3}$ the width of the flange or moment connection plate delivering the concentrated force.
2. The thickness of stiffeners shall be not less than $t_b/2$.**
3. When the concentrated force delivered occurs on only one column flange, the stiffener length need not exceed $\frac{1}{2}$ the column depth.
4. The weld joining stiffeners to the column web shall be sized to carry the force in the stiffener caused by unbalanced moments on opposite sides of the column.

1.15.5.5 Connections having high shear in the column web shall be investigated.†

- Except where other codes may govern. For example, see Section 4(D) "Recommended Lateral Force Requirements and Commentary", Structural Engineers Assoc. of California, 1975.
- See Commentary Sect. 1.15.5 for comment on width-thickness ratio of stiffeners.
- See Commentary Sect. 1.5.1.2.

Suggested Addition to Specification, (Popov 29Aug79):

Study the effect of stiffening in rectangular tubes and include in the Specification and the Monograph Volume SB.

Comments:

Foreman (6Nov80): Since this suggestion requires further research and study, I feel that at this time it should not be recommended to the Main Committee for inclusion in the specification. We could, however, bring this need for further investigation to the attention of the Main Committee.

Iffland (12Jan81): Are stiffened rectangular tubes used so often that they warrant special study and inclusion in the specifications?

RECOMMENDED ACTION: CBS Refer the matter to RCSC.

Item 1.18.2 (Specification)

The effect of braced frames or shear walls in laterally restraining other columns is recognized in this section.

Similar conditions exist for other types of systems, such as the composite tubular system, and various forms of framed tubes, as shown below.

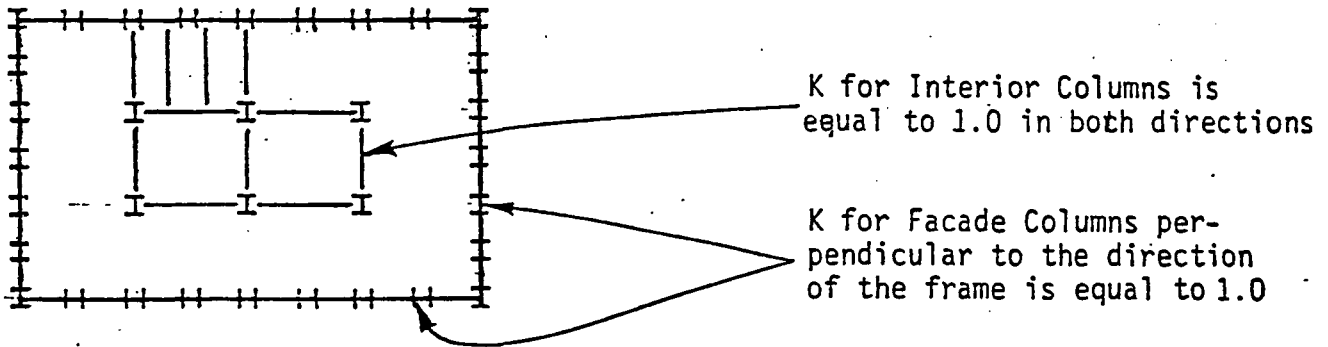

Suggested Addition to Specification, (Iyengar)

(1.18.2)

I suggest that this section be expanded to include such cases. An appropriate title for this subsection may be "Laterally Restrained Frame."

RECOMMENDED ACTION: CBS Refer the matter to CTBUH.

SECTION 1.21 COLUMN BASES

1.21.1 Loads

Proper provision shall be made to transfer the column loads and moments to the footings and foundations.

1.21.2 Alignment

Column bases shall be set level and to correct elevation with full bearing on the masonry.

1.21.3 Finishing

Column bases and base plates shall be finished in accordance with the following requirements:

1. Rolled steel bearing plates 2 inches or less in thickness may be used without milling,* provided a satisfactory contact bearing is obtained; rolled steel bearing plates over 2 inches but not over 4 inches in thickness may be straightened by pressing or, if presses are not available, by milling for all bearing surfaces (except as noted in subparagraph 3 of this Section), to obtain a satisfactory contact bearing; rolled steel bearing plates over 4 inches in thickness shall be milled for all bearing surfaces (except as noted in subparagraph 3 of this Section).
2. Column bases other than rolled steel bearing plates shall be milled for all bearing surfaces (except as noted in subparagraph 3 of this Section).
3. The bottom surfaces of bearing plates and column bases which are grouted to insure full bearing contact on foundations need not be milled.

Suggested Addition to Specification, (Popov 29Aug79):

Include more information on column bases and anchorage.

Comments:

Foreman (6Nov80): I would like to hear a discussion about what is meant by "more information" prior to making any recommendations.

Munse (24Dec80): What information? Suggestions are needed.

Iffland (12Jan81): Why pick out this one subject to provide more information for?

RECOMMENDED ACTION: Refer the matter to CBS for a possible appointment of study committee.

SECTION 2.1 SCOPE

Subject to the limitations contained herein, simple and continuous beams, braced and unbraced planar rigid frames, and similar portions of structures rigidly constructed so as to be continuous over at least one interior support,* may be proportioned on the basis of plastic design, i.e., on the basis of their maximum strength. This strength, as determined by rational analysis, shall be not less than that required to support a factored load equal to 1.7 times the given live load and dead load, or 1.3 times these loads acting in conjunction with 1.3 times any specified wind or earthquake forces.

Rigid frames shall satisfy the requirements for Type 1 construction in the plane of the frame, as provided in Sect. 1.2. This does not preclude the use of some simple connections, provided that the provisions of Sect. 2.3 are satisfied. Type 2 construction is permitted for members between rigid frames. Connections joining a portion of a structure designed on the basis of plastic behavior with a portion not so designed need be no more rigid than ordinary seat-and-top-angle or ordinary web connections.

Where plastic design is used as the basis for proportioning continuous beams and structural frames, the provisions relating to allowable working stress, contained in Part 1, are waived. Except as modified by these rules, however, all other pertinent provisions of Part 1 shall govern.

It is not recommended that crane runways be designed continuous over interior vertical supports on the basis of maximum strength. However, rigid frame bents supporting crane runways may be considered as coming within the scope of the rules.

Suggested Addition to Specification, (Khan, Viest, Lu, Popov 29Aug79):

Make Part 2 more complete.

Background Information: Is part two sufficiently complete (Khan)? Eventually ATC-3 (1978) will force the use of plastic design in the consideration of the ultimate state (Viest). The proposed Japanese specification requires the consideration of plastic behavior (ductility) in determining the design earthquake forces (Lu). The California State Department of Architecture requires plastic analysis of certain structures (Popov).

RECOMMENDED ACTION: Refer the matter to CBS for a possible appointment of study committee.

SECTION 2.1 SCOPE

The Specification recognizes three categories of profiles, classified according to the ability to resist local buckling of elements of the cross section when subject to compressive stress. These categories are: (1) non-compact, (2) compact, and (3) plastic design. The elements of *non-compact* sections (Sect. 1.9) will not buckle locally when subject to elastic limit strains. Elements of *compact* sections (Sect. 1.5.1.4.1) are proportioned so that the cross section may be strained in bending to the degree necessary to achieve full plastification of the cross section; however, the reserve for inelastic strains is adequate only to achieve modest redistribution of moments. The elements of *plastic design* sections (Sect. 2.7) are proportioned so that they will not only achieve full plastification of the cross section, but will remain stable while being bent through an appreciable angle at a constant plastic moment up to the point where strain hardening is initiated. Thus, plastic design cross sections are capable of providing the hinge rotations that are counted upon in the plastic method of analysis.

The superior bending strength of compact sections is recognized in Part 1 of the Specification by increasing the allowable bending stress to $0.66F_y$, and by permitting 10% redistribution of moment. By the same token, the logical load factor for plastically designed beams is given by the equation

$$F = \frac{F_y}{0.66F_y} \times (\text{shape factor})$$

For such shapes listed in the AISC *Steel Construction Manual*, the variation of shape factor is from 1.10 to 1.23, with a mode of 1.12. Then, the corresponding load factor must vary from 1.67 to 1.86, with a mode of 1.70. Such a load factor is consistent and in better balance with that inherent in the allowable working stresses for tension members and deep plate girders.

Research⁵⁶ on the ultimate strength of heavily loaded columns subjected to concurrent bending moments has provided data which justifies a load factor, for such members, that is the same as that provided for members subject to bending only, namely 1.7. Consistent with the $\frac{1}{3}$ increase in allowable stress permitted in Part 1 of the Specification, the load factor to be used in designing for gravity loading combined with wind or seismic loading is 1.3.

Based on ~~continuing~~ research at Lehigh University on multistory framing,^{57,58} application of the Specification provisions includes the complete design of braced and unbraced planar frames in high-rise buildings. Systematic procedures for application of plastic design in proportioning the members of such frames have been developed^{59,60} and are available in the current literature.

Suggested Addition to Commentary, (Popov 31Aug79):

Add a new paragraph to Commentary Section 2.1:

Methods of inelastic analysis are ~~now~~ well developed and include both gravity and lateral force analyses. Refer to Chapter SB-3 of the Monograph (Council on Tall Buildings, 1979).

RECOMMENDED ACTION: Refer matter to AISC Specification Ad hoc Earthquake Committee.

SECTION 2.1 SCOPE

The Specification recognizes three categories of profiles, classified according to the ability to resist local buckling of elements of the cross section when subject to compressive stress. These categories are: (1) non-compact, (2) compact, and (3) plastic design. The elements of *non-compact* sections (Sect. 1.9) will not buckle locally when subject to elastic limit strains. Elements of *compact* sections (Sect. 1.5.1.4.1) are proportioned so that the cross section may be strained in bending to the degree necessary to achieve full plastification of the cross section; however, the reserve for inelastic strains is adequate only to achieve modest redistribution of moments. The elements of *plastic design* sections (Sect. 2.7) are proportioned so that they will not only achieve full plastification of the cross section, but will remain stable while being bent through an appreciable angle at a constant plastic moment up to the point where strain hardening is initiated. Thus, plastic design cross sections are capable of providing the hinge rotations that are counted upon in the plastic method of analysis.

The superior bending strength of compact sections is recognized in Part 1 of the Specification by increasing the allowable bending stress to $0.66F_y$, and by permitting 10% redistribution of moment. By the same token, the logical load factor for plastically designed beams is given by the equation

$$F = \frac{F_y}{0.66F_y} \times (\text{shape factor})$$

For such shapes listed in the AISC *Steel Construction Manual*, the variation of shape factor is from 1.10 to 1.23, with a mode of 1.12. Then, the corresponding load factor must vary from 1.67 to 1.86, with a mode of 1.70. Such a load factor is consistent and in better balance with that inherent in the allowable working stresses for tension members and deep plate girders.

Research⁵⁶ on the ultimate strength of heavily loaded columns subjected to concurrent bending moments has provided data which justifies a load factor, for such members, that is the same as that provided for members subject to bending only, namely 1.7. Consistent with the $\frac{1}{3}$ increase in allowable stress permitted in Part 1 of the Specification, the load factor to be used in designing for gravity loading combined with wind or seismic loading is 1.3.

Based on ~~continuing~~ research at Lehigh University on multistory framing,^{57,58} application of the Specification provisions includes the complete design of braced and unbraced planar frames in high-rise buildings. Systematic procedures for application of plastic design in proportioning the members of such frames have been developed^{59,60} and are available in the current literature.

Suggested Addition to Commentary, (Popov, 31Aug79):

It is now well documented that ductile behavior of structural systems significantly reduces the force magnitudes that develop during a strong earthquake (Newmark and Hall, 1976). Vibration of a structure behaving in a ductile manner is moderated in a manner somewhat analogous to that of viscous damping of elastic systems. Properly designed conventional moment-resisting framing using structural steel possesses these desirable characteristics. Some new framing schemes (Roeder and Popov, 1978; Popov and Roeder, 1978) attempt to combine the ductility of a moment-resisting frame with the stiffness of a diagonally braced frame.

RECOMMENDED ACTION: Refer matter to AISC Specification Ad hoc Earthquake Committee.

SECTION 2.4 COLUMNS

Members subject to combined axial load and bending moment shall be proportioned to satisfy the following interaction formulas:

$$\frac{P}{P_{cr}} + \frac{C_m M}{\left(1 - \frac{P}{P_e}\right) M_m} \leq 1.0 \quad (2.4-2)$$

$$\frac{P}{P_y} + \frac{M}{1.18 M_p} \leq 1.0; \quad M \leq M_p \quad (2.4-3)$$

Suggested Specification Change, (Driscoll 14Sep79):

Replace Equations (2.4-2) and (2.4-3) with the following: (Council on Tall Buildings, 1979, pp. 255-256)

$$\left(\frac{M_x}{M_{ux}}\right)^\beta + \left(\frac{M_y}{M_{uy}}\right)^\beta = 1.0 \quad (2.4-2)$$

At a braced location

$$\beta = 1.6 - \frac{\frac{P}{P_y}}{2 \ln\left(\frac{P}{P_y}\right)} \quad (2.4-3)$$

$$M_{ux} = 1.18 M_{px} \left[1 - \left(\frac{P}{P_y}\right)\right] \quad (2.4-4a)$$

$$M_{uy} = 1.19 M_{py} \left[1 - \left(\frac{P}{P_y}\right)^2\right] \quad (2.4-4b)$$

To check stability between braced points use

$$\left(\frac{C_{mx} M_x}{M_{ux}} \right)^\beta + \left(\frac{C_{my} M_y}{M_{uy}} \right)^\beta \leq 1.0 \quad (2.4-5a)$$

$$\beta = 0.4 + \frac{P}{P_y} + \frac{B}{D} \geq 1.0 \quad \text{when } \frac{B}{D} \geq 0.3 \quad (2.4-5b)$$

$$\beta = 1.0 \quad \text{when } \frac{B}{D} < 0.3 \quad (2.4-5c)$$

$$M_{ux} = M_m \left[1 - \left(\frac{P}{P_u} \right) \right] \left[1 - \left(\frac{P}{P_{ex}} \right) \right] \quad (2.4-6a)$$

$$M_{uy} = M_{py} \left[1 - \left(\frac{P}{P_u} \right) \right] \left[1 - \left(\frac{P}{P_{ey}} \right) \right] \quad (2.4-6b)$$

$$P_u = \left[1 - \frac{(\ell/r)^2}{2C_c^2} \right] F_y A \quad (2.4-7)$$

where

$$C_c = \sqrt{\frac{2\pi^2 E}{F_y}}$$

when ℓ/r exceeds C_c

$$P_u = \frac{\pi^2 EA}{(\ell/r)^2} \quad (2.4-8)$$

in which

P = applied axial load, kips

P_y = axial load at full yield condition

P_u = ultimate load of axially loaded column

P_{ex} = Euler buckling load about x axis of bending

P_{ey} = Euler buckling load about y axis of bending

C_{mx} & C_{my} are the C_m coefficient defined in Section 1.6.1

M_x = bending moment about x axis of member.

M_y = bending moment about y axis of member

M_m = maximum moment that can be resisted by the member in the absence of axial load, kip-feet

M_{ux} = maximum end moment about x axis of member, including axial load but in absence of other moment

M_{uy} = maximum end moment about y axis of member, including axial load but in absence of other moment

M_{px} = plastic moment about x axis of member, kip-feet = $Z_x F_y$

Z_x = plastic section modulus about x axis of member, inches³

M_{py} = plastic moment about y axis of member, kip-feet = $Z_y F_y$

Z_y = plastic section modulus about y axis of member, inches³

β = exponent

B and D = cross-sectional dimensions of the column section

ℓ/r = largest slenderness ratio of the column

Comments:

McGuire (22Oct80): It's time for a change in the interaction equations, but I am not sure that the proposed changes are the best ones. Recommend to Main Committee for detailed evaluation by a task committee.

Viest (30Oct80): The proposed new requirements are far too complicated, need further study and simplification before they are ready for the Specification.

Popov (14Dec80): Too complicated.

Milek (2Jan81): Place in an appendix as an accepted more refined method.

Item 2.4A (cont.)

Iffland (12Jan81): It is suggested that the proposal change be included in the specification commentary to be used at the option of the designer. Specifications should be made simpler, not more complicated.

RECOMMENDED ACTION: CBS Refer the matter to SSRC.

SECTION 2.4 COLUMNS

Formulas (2.4-2) and (2.4-3)¹ will be recognized as similar in type to Formulas (1.6-1a) and (1.6-1b) in Part 1, except that they are written in terms of factored loads and moments, instead of allowable stresses at service loading. As in the case of Formulas (1.6-1a) and (1.6-1b), P_{cr} is computed on the basis of l/r_x or l/r_y , whichever is larger, for any given unbraced length.²

A column is considered to be fully braced if the slenderness ratio l/r_y between the braced points is less than or equal to that specified in Sect. 2.9. When the unbraced length ratio of a member bent about its strong axis exceeds the limit specified in Sect. 2.9, the rotation capacity of the member may be impaired, due to the combined influence of lateral and torsional deformation, to such an extent that plastic hinge action within the member cannot be counted upon. However, if the computed value of M is small enough so that the limitations of Formulas (2.4-2) and (2.4-3) are met, the member will be strong enough to function at a joint where the required hinge action is provided in another member entering the joint. An assumed reduction in moment-resisting capacity is provided by using the value M_m , computed from Formula (2.4-4), in Formula (2.4-2).

Formula (2.4-4) was developed empirically* on the basis of test observations and provides an estimate of the critical lateral buckling moment, in the absence of axial load, for the case where $M_1/M_2 = -1.0$ (single curvature bending). For other values of M_1/M_2 , adjustment is provided by using the appropriate C_m value as defined in Sect. 1.6.1.

Formula (2.4-4) is to be used only in connection with Formula (2.4-2).

Space frames containing plastically designed planar rigid frames are assumed to be supported against sidesway normal to these frames. Depending upon other conditions of restraint, the basis for determination of proper values for P_{cr} and P_e and M_m , for a plastically designed column oriented to resist bending about its strong axis, is outlined in Table C2.4.1. In each case l is the distance between points of lateral support corresponding to r_x or r_y , as applicable. When K is indicated, its value is governed by the provisions of Sect. 1.8.3 of the Specification.

TABLE C2.4.1

	Braced Planar Frames	One- and Two-Story Unbraced Planar Frames
P_{cr}	Use larger ratio, $\frac{l}{r_y}$ or $\frac{l}{r_x}$	¹ Use larger ratio, $\frac{l}{r_y}$ or $\frac{Kl}{r_x}$
P_e	Use l/r_x	¹ Use Kl/r_x
M_m	Use l/r_y	Use l/r_y
¹ Webs of columns assumed to be in plane of frame.		

Suggested Addition to Commentary, (Driscoll 14Sep79):

SECTION 2.4 COLUMNS

Prior editions of this specification used column formulas limiting bending to one axis and similar in type to Formulas (1.6-1a) and (1.6-1b) in Part 1, except that they are written in terms of factored loads and moments, instead of allowable stresses at service loading.

Recently, extensive theoretical studies of the behavior of steel H-columns subject to compression combined with biaxial bending have been made, using computer models (Chen and Atsuta, 1973, 1977; Santathadaporn and Chen, 1973). As a result of these studies, direct and accurate approximate formulas have been proposed as a method for design. Herein are reviewed the existing design requirements, along with the recently proposed new design procedures for biaxially loaded beam-columns.

An examination of Fig. C2.4.1 clarifies many of the premises of the present design concept. It represents, in two dimensions, what is essentially a three-dimensional surface describing the maximum strength of columns subject to axial load and biaxial bending moments. It shows a typical maximum strength interaction surface for a particular beam-column length.

If the solid lines on the mutually perpendicular planes of Fig. C2.4.1 represent the actual failure curves under the relevant restricted loading conditions, then the dotted lines represent the existing design requirements. In particular, the straight-line interaction of biaxial moment for a given axial load corresponds to the current AISC design expressions (AISC, ~~1969~~), as well as CRC Eq. 6.19 of the second edition of the CRC Guide to Design Criteria for Metal Compression Members (Johnston, 1966) and to SSRC Eq. 8.29 of the Guide to Stability Design Criteria for Metal Structures (Structural Stability Research Council, 1976). Recent research has shown that the interaction of moments about the orthogonal axes is not linear (Tebedge and Chen, 1974). On the contrary, the interaction curve resembles more closely the quadrant of a circle (see Fig. C2.4.2). It is important to note that if a member is fully loaded under axial load and bending about one axis, then there is no spare capacity to accept moment about the other axis. However, as the loading decreases slightly below the maximum, capacity rapidly develops to accept bending about the other axis.

Extensive comparisons have also been made with the results of tests on actual columns, providing final confirmation of the validity of the interaction formulas (Springfield and Hegan, 1973). Springfield's evaluation of Chen's interaction equation (Eq. 2.4-2) showed that, for Birnstiel's tests, Eq. 2.4-2 was quite reliable [Mean 1.01, Standard Deviation 0.074]. A further verification of Chen's equation is its good agreement with Birnstiel's incremental analytical procedure (Birnstiel and Michalos, 1963). Aside from one result, in which the error was 7% conservative, all the other values agree to within 3%. (Council on Tall Buildings, 1979, pp. 254-257).

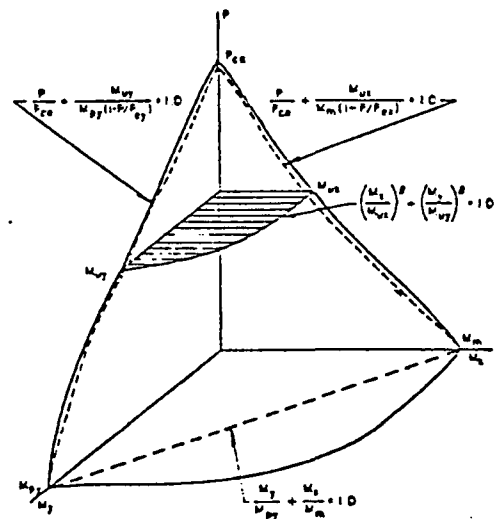

Fig. C2.4.1 Typical maximum strength interaction surface for particular column of known length subject to biaxial bending

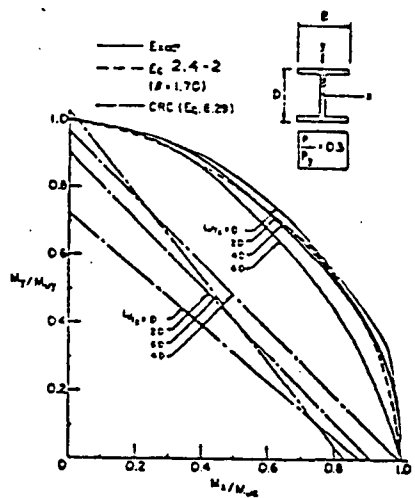

Fig. C2.4.2 Comparison of interaction curves for long columns

A column is considered to be fully braced if the slenderness ratio l/r_y between the braced points is less than or equal to that specified in Sect. 2.9. When the unbraced length ratio of a member bent about its strong axis exceeds the limit specified in Sect. 2.9, the rotation capacity of the member may be impaired, due to the combined influence of lateral and torsional deformation, to such an extent that plastic hinge action within the member cannot be counted upon. However, if the computed value of M is small enough so that the limitations of Formula 2.4-2 are met, the member will be strong enough to function at a joint where the required hinge action is provided in another member entering the joint. An assumed reduction in moment-resisting capacity is provided by using the value M_m , computed from Formula 2.4-9, in Formula (2.4-2).

Formula (2.4-9) was developed empirically on the basis of test observations and provides an estimate of the critical lateral buckling moment, in the absence of axial load, for the case where $M_1/M_2 = -1.0$ (single curvature bending).

Formula (2.4-9) is to be used only in connection with Formula (2.4-2).

~~Space frames containing plastically designed planar rigid frames may be braced to be supported against sideway normal to these frames. Depending upon other conditions of restraint, the basis for determination of proper values for P_{cr} and P_e and M_m , for a plastically designed column oriented to resist bending about its strong axis, is outlined in Table C2.4.1. In each case l is the distance between points of lateral support corresponding to r_x or r_y , as applicable. When K is indicated, its value is governed by the provisions of Sect. 1.8.3 of the Specification.~~

Table C2.4.1

	Unbraced Frames	Braced Frames	
		(a) Braced in both directions	(b) Braced in one direction
P_{cr}	*Use larger ratio l/r_y or l/r_x	*Use larger ratio l/r_y or l/r_x	*Use larger ratio l/r_y or l/r_x
P_{ex}	Use l/r_x	Use l/r_x	
P_{ey}	Use l/r_y		Use l/r_y
M_m	Use l/r_y	Use l/r_y	Use l/r_y

*A frame analysis considering P-delta effects should be used in determining member forces.

RECOMMENDED ACTION: CBS Refer the matter to SSRC.

SECTION 2.4 COLUMNS

Members subject to combined axial load and bending moment shall be proportioned to satisfy the following interaction formulas:

$$\frac{P}{P_{cr}} + \frac{C_m M}{\left(1 - \frac{P}{P_e}\right) M_m} \leq 1.0 \quad (2.4-2)$$

$$\frac{P}{P_y} + \frac{M}{1.18M_p} \leq 1.0; \quad M \leq M_p \quad (2.4-3)$$

Suggested Specification Change, (Driscoll 14Sep79)

Revise equation (2.4-4) as follows and re-number to (2.4-9):

For columns braced in the weak direction:

$$M_m = M_{px}$$

For columns unbraced in the weak direction:

$$M_m = \left[1.07 - \frac{(\ell/r_y)\sqrt{F_y}}{3160} \right] M_{px} \leq M_{px} \quad (2.4-9)$$

Comments:

McGuire (22Oct80): Dependent upon 2.4(A).

Recommendation for 2.4(A) applies.

Viest (30Oct80): As I see it, if there is no change in Eqs. (2.4-2) and (2.4-3), there should not be any change in Eq. (2.4-4). This is just editorial matter.

Popov (14Dec80): Too complicated.

Iffland (12Jan81): See my comment under Specification Item 2.4(A).

RECOMMENDED ACTION: CBS Refer the matter to SSRC.

The following additional suggestions do not refer to particular Specification or Commentary items and are simply designated by a letter.

LRFD

Suggestion: (Foreman 13Sep79):

LRFD should be included in the Specification as a separate part, i.e. treat it similarly to plastic design, as Part 3.

Comments:

Galambos (19Sep80): Will be completely separate specification.

McGuire (22Oct80): Shouldn't this be a separate specification, similar to the two Canadian specifications.

Munse (24Dec80): LRFD is under study now.

APPROVED by CBS. Incorporate in next revision of AISC Specifications.

METHODS OF ANALYSIS

Suggestion: (Gaylord 29Aug79):

Should the Specification prescribe methods of analysis?

Background Information: Question of proportioning structure as a whole as against proportioning of members in the present AISC.

Comments:

Galambos (19Sep80): Analysis should not be prescribed in a materials specification.

Higgins (6Oct80): It is not clear what is intended under "methods of analysis."

McGuire (22Oct80): Sounds similar to my concerns regarding nonlinear analysis (page 31 of Report 440.6). Should be considered by the same group.

Munse (24Dec80): I do not feel this belongs in the specification.

Milek (2Jan81): More study and discussion necessary. I am not certain what is implied by the recommendation.

Iffland (12Jan81): I don't think the specifications should get involved in methods of analysis. Specifications should only cover individual member design and state that overall action must be considered.

RECOMMENDED ACTION: Refer the matter to CBS for a possible appointment of study committee.

DYNAMIC RESPONSE

Suggestion: (Milek, Khan 29Aug79):

Include more information on dynamic response.

Background Information: When the drift is greater than 1/500 it is an indication that one should consider a wind tunnel test.

Comments:

Galambos (19Sep80): This is a matter which goes beyond the scope of a materials specification.

Foreman (6Nov80): See my comment on Commentary Item 1.3.5 (p.4).

RECOMMENDED ACTION: Refer the matter to CBS for a possible appointment of study committee.

DRIFT CONTROL

Suggestion: (Popov 29Aug79):

Drift control needs to be added for drift limit and design ultimate load.

Comments:

Galambos (19Sep80): This is a matter which goes beyond the scope of a materials specification.

Higgins (6Oct80): See my comments on Commentary Item 1.3.5 (p.4).

Foreman (6Nov80): See my comment on Commentary Item 1.3.5 (p.4).

Milek (2Jan81): More study and discussion necessary. I am not certain what is implied by the recommendation.

Iffland (12Jan81): This is not a matter of safety.

RECOMMENDED ACTION: Refer the matter to CBS for a possible appointment of study committee.

FACTOR OF SAFETY FOR DYNAMIC LOADING

Suggestion: (Iffland 29Aug79):

The present one-third increase for factor of safety for dynamic loading needs to be studied. It is not the right approach.

Comments:

Foreman (6Nov80): Since this suggestion requires further research and study, I feel that at this time it should not be recommended to the Main Committee for inclusion in the specification. We could, however, bring this need for further investigation to the attention of the Main Committee.

Milek (2Jan81): More study and discussion necessary. I am not certain what is implied by the recommendation.

RECOMMENDED ACTION: Refer the matter to CBS for a possible appointment of study committee.

PERFORMANCE

Suggestion: (Galambos, Khan 29Aug79):

Add a separate appendix to handle the topic of performance.

Background Information: The present Specification does not speak directly to performance. Are we concerned about it (Khan)? The consensus was "yes". The Canadians handle this by a separate appendix (Galambos).

RECOMMENDED ACTION: Refer the matter to CBS for a possible appointment of study committee.

CLADDING

Suggestion: (Munse 29Aug79):

Include in the Commentary whether the failures in cladding are due to fracture or fatigue.

Comments:

McGuire (22Oct80): Suggestion requires further explanation.

Munse (24Dec80): Statement is poorly worded. Need a warning in the Commentary concerning the possibility of fatigue or fracture in cladding fastenings.

Milek (2Jan81): More study and discussion necessary. I am not certain what is implied by the recommendation.

RECOMMENDED ACTION: Refer the matter to CBS for a possible appointment of study committee.

NIL-DUCTILITY

Suggestion: (Khan 29Aug79):

Include information on nil-ductility.

Background Information: There is always a question about this in cold areas and construction during winter. Also fractures of big weldments after welding.

Comments:

Galambos (19Sep80): What is it?

Munse (24Dec80): Needs to be carefully prepared.

RECOMMENDED ACTION: CBS Refer the matter to WRC.

LAMELLAR TEARING

Suggestion: (Driscoll 29Aug79):

Insert in the Commentary material on lamellar tearing on page 459 and refer to pages 554-557 of the Monograph Vol. SB (Council on Tall Buildings, 1979).

Design. Lamellar tearing generally results when a high degree of restraint is built into a weldment and produces large strains in the through-thickness direction of rolled steel plates or shapes. Therefore, care must be exercised in design to provide flexibility that will relieve the strains that might develop as a result of weld shrinkage, particularly in a highly restrained weldment. In addition, the welding processes and procedures should be selected so as to reduce to a minimum the susceptibility of a weldment to lamellar tearing.

Recommendations. Farrar et al. (1969) made suggestions for reducing the risk of lamellar tearing, which involve decohesion at inclusions or inclusion clusters, followed by linkage of the decohesed regions by shear or by normal ductile fracture for smaller inclusions. To reduce the risk of lamellar tearing of a corner joint, they propose the redesign shown in Fig. 6.63, because the fusion boundary is no longer parallel to the plane of the plate. Some other remedial measures that can be taken to reduce the risk of lamellar tearing are shown in Fig. 6.64. They are: (1) The use of low-strength weld metals; (2) modified run procedure; (3) buttering; and (4) balanced welding (Farrar et al., 1969). Further recommendations can be found in a commentary prepared by the American Institute of Steel Construction (AISC, 1973).

Heuschkel (1971) showed that decohesion cracking parallel to the plate surfaces occurred most commonly in corner and tee joints when welded under conditions of high restraint, whereas minimum weldment susceptibility to decohesion cracking occurred in clean, ductile, tough steels, and where the designs and welding procedures involved minimum rigidity and the lowest residual stresses. (Council on Tall Buildings, 1979, p. 452).

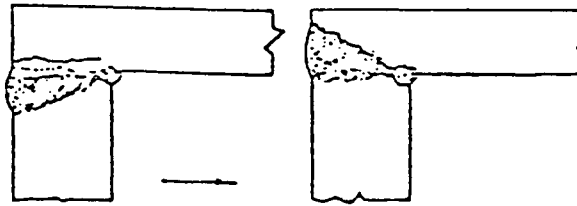

Fig. 6.63 Possible modification of corner joint to reduce risk of tearing

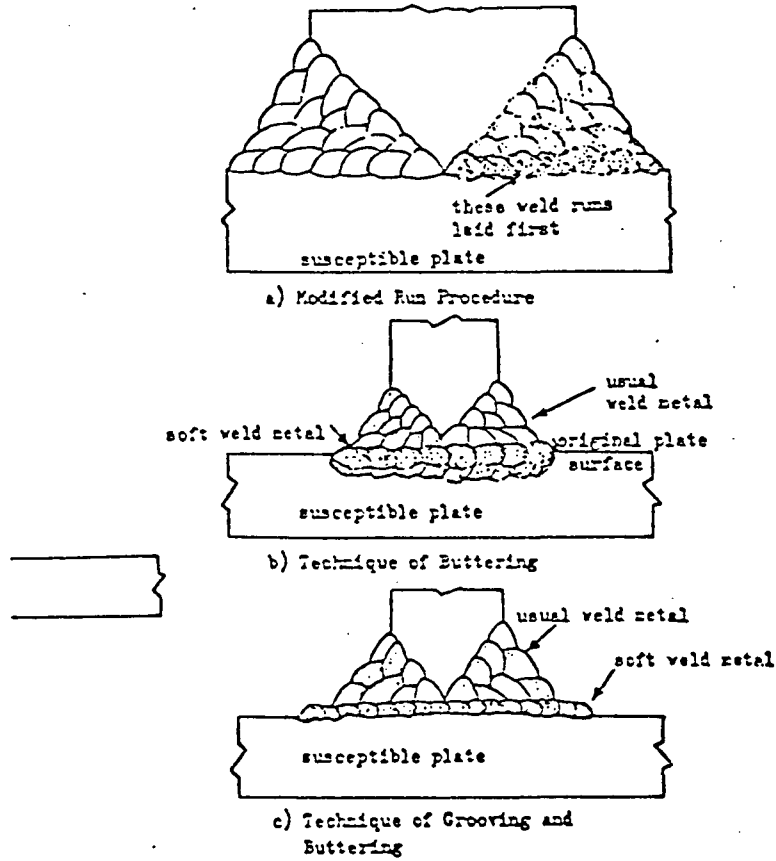

Fig. 6.64 Precautions or techniques to reduce risk of lamellar tearing

RECOMMENDED ACTION: Refer the matter to CBS for a possible appointment of study committee.

STEEL/CONCRETE CONNECTIONS

Suggestion : (Milek 29Aug79):

Include information on connecting steel beams to concrete columns and walls.

RECOMMENDED ACTION: Refer the matter to CBS for a possible appointment of study committee.

DIFFERENTIAL MOVEMENT OF COLUMNS

Suggestion: (Khan 29Aug79):

Include in the Commentary information on differential movement of columns.

Background Information: When steel and concrete columns are intermixed, consideration must be given to the differential movement (because of concrete shrinkage). Example: One Shell Square.

Comments:

Galambos (19Sep80): This is a matter which goes beyond the scope of a materials specification.

Iffland (12Jan81): Not proper for a specification.

RECOMMENDED ACTION: Refer the matter to CBS for a possible appointment of study committee.

MIXED CONSTRUCTION

Suggestion: (McGuire 4Sep79):

Should there be a new section in the Specification on Mixed Construction?

Background Information: I just raise the general question of whether or not it is time to have some provisions for mixed construction (particularly columns) in the AISC Specification.

Note: Suggestions are contained on pp. ^{30,31,40}~~24-26~~ of this report.

RECOMMENDED ACTION: Refer the matter to CBS for a possible appointment of study committee.

COMMENTARY FOR TALL BUILDINGS

Suggestion: (Higgins 29Aug79):

Perhaps there should be a separate, short, concise statement in the Commentary about items that are particularly unique to tall buildings.

Comments:

Foreman (6Nov80): I like the suggestion, but feel that recommendation to the Main Committee should not be made, unless we have already discussed and prepared such concise statement.

RECOMMENDED ACTION: Refer to Tall Building Study Committee.

SCOPE

Suggestion: (Gaylord 29Aug79):

Should the Specification go beyond individual members and deal with frames?

Comments:

Galambos (19Sep80): This is a matter which goes beyond the scope of a materials specification.

Foreman (6Nov80): Since Item No. 1.8 already deals with an individual member (column) versus frame situation, it would be in order to discuss what other member vs. frame informations would be useful for inclusion in the specifications and/or commentary.

Iffland (12Jan81): See my comment on Item (B)(p.⁵⁵~~19~~).

RECOMMENDED ACTION: Refer the matter to CBS for a possible appointment of study committee.

SEISMIC PROVISIONS

Suggestion: (Driscoll 29Aug79):

Include in the Specification new seismic information from the Monograph Vol. SB (Council on Tall Buildings, 1979).

Comments:

Galambos (19Sep80): This is a matter which goes beyond the scope of a materials specification.

McGuire (22Oct80): Could be too much for Specification. Why not better references to ANSI A58, ATC-3, or other documents?

Iffland (12Jan81): Reference should be made to ANSI or another document. Same comment as 1.3.5 (A)(p. 6).

RECOMMENDED ACTION: Refer matter to AISC Specification Ad hoc Earthquake Committee.

Table 1

ABBREVIATIONS

- CBS - Committee on Building Specifications
- CTBUH - Council on Tall Buildings and Urban Habitat
- JSBI - "Iffland Committee"
- RCSC - Research Council on Structural Connections
- SSRC - Structural Stability Research Council
- WRC - Welding Research Council

BALLOT

Page	Item No.	Topic	By	Recommend to Main Committee		
				Yes	No*	Further Committee Discussion Needed*
<u>SPECIFICATION CHANGES</u>						
3	1.3.5	Wind	Foreman	<u>2</u>	<u>3</u>	<u>4</u>
4	1.7.1	Fatigue	Munse	<u>8</u>	<u>—</u>	<u>1</u>
5	1.11.1	Effective Width	Viest	<u>10</u>	<u>1</u>	<u>—</u>
6	2.4(A)	Columns (Eqs. 2.4-2 & 3)	Driscoll	<u>5</u>	<u>2</u>	<u>2</u>
8	2.4(B)	Columns (Eq. 2.4-4)	Driscoll	<u>7</u>	<u>2</u>	<u>1</u>
<u>COMMENTARY CHANGES</u>						
9	1.2(A)	Type 2 Construction	McGuire, Iffland, Beedle	<u>7</u>	<u>1</u>	<u>2</u>
9	1.2(B)	Lamellar Tearing	Munse	<u>7</u>	<u>1</u>	<u>1</u>
9	1.2(C)	Brittle Fracture	Munse	<u>5</u>	<u>1</u>	<u>3</u>
10	1.3.5	Wind	Foreman	<u>4</u>	<u>1</u>	<u>4</u>
12	1.7	Fatigue	Munse	<u>7</u>	<u>1</u>	<u>1</u>
13	1.11.1	Effective Width	Viest	<u>9</u>	<u>—</u>	<u>—</u>
14	1.15.A	Connections (Heavy Bolted)	Chen	<u>7</u>	<u>—</u>	<u>3</u>
15	2.1(A)	Plastic Analysis	Popov	<u>10</u>	<u>—</u>	<u>—</u>
15	2.1(B)	Ductile Behavior	Popov	<u>8</u>	<u>—</u>	<u>2</u>
16	2.4	Columns	Driscoll	<u>7</u>	<u>1</u>	<u>2</u>
<u>OTHER SUGGESTIONS</u>						
20	1.2	Type 2 Construction	McGuire	<u>8</u>	<u>—</u>	<u>1</u>
21	1.3.5(A)	Wind	Gaylord	<u>4</u>	<u>2</u>	<u>2</u>
21	1.3.5(B)	Wind	Khan, Viest	<u>5</u>	<u>1</u>	<u>2</u>
21	1.3.5(C)	Wind	Popov, Galambos	<u>5</u>	<u>1</u>	<u>2</u>
22	1.3.6	Earthquakes & Hurricanes	Gaylord	<u>4</u>	<u>2</u>	<u>2</u>
23	1.5.1.3	Minor Axis Bending	Iffland	<u>4</u>	<u>—</u>	<u>5</u>
24	1.5.1.3	End Restraint & Initial Column Crookedness	Iffland	<u>4</u>	<u>1</u>	<u>4</u>
25	1.5.1.4	Lateral Buckling	McGuire	<u>4</u>	<u>1</u>	<u>2</u>
28	1.6	Combined Stresses	McGuire	<u>7</u>	<u>—</u>	<u>1</u>
29	1.6	Biaxial Bending	Iffland	<u>6</u>	<u>—</u>	<u>3</u>

*In case of any "No" or "Further Discussion" votes, comment is to be made on the attached page.

Page	Item No.	Topic	By	Recommend to Main Committee		
				Yes	No	Further Committee Discussion Needed
31	1.8	Nonlinear Analysis	McGuire	<u>7</u>	<u>1</u>	<u>1</u>
33	1.8	Frame vs. Column Stability	Iffland	<u>7</u>	<u>—</u>	<u>2</u>
34	1.10	Plate Girders	McGuire	<u>7</u>	<u>1</u>	<u>—</u>
35	1.11(A)	Concrete-Encased Steel Columns	Viest	<u>9</u>	<u>—</u>	<u>—</u>
35	1.11(B)	Concrete-Filled Tubular Columns	Viest	<u>9</u>	<u>—</u>	<u>—</u>
36	1.11.2	Clustering of Studs	Milek	<u>8</u>	<u>—</u>	<u>—</u>
38	1.13.2	Vibration	Foreman	<u>8</u>	<u>—</u>	<u>—</u>
39	1.15	End Plate Connections	McGuire	<u>7</u>	<u>1</u>	<u>1</u>
41	1.15.5	Rectangular Tube Stiffening	Popov	<u>6</u>	<u>1</u>	<u>1</u>
42	1.21	Column Bases	Popov	<u>5</u>	<u>—</u>	<u>3</u>
43	2	Completeness	Khan, Viest, Lu	<u>7</u>	<u>—</u>	<u>1</u>
44	A	LRFD	Foreman	<u>3</u>	<u>1</u>	<u>4</u>
44	B	Methods of Analysis	Gaylord	<u>2</u>	<u>3</u>	<u>3</u>
44	C	Dynamic Response	Milek, Khan	<u>6</u>	<u>1</u>	<u>1</u>
44	D	Drift Control	Popov	<u>4</u>	<u>2</u>	<u>2</u>
44	E	Factor of Safety for Dynamic Loading	Iffland	<u>5</u>	<u>1</u>	<u>2</u>
45	F	Performance	Galambos, Khan	<u>7</u>	<u>—</u>	<u>1</u>
45	G	Cladding	Munse	<u>3</u>	<u>—</u>	<u>5</u>
45	H	Nil-Ductility	Khan	<u>6</u>	<u>1</u>	<u>1</u>
45	I	Lamellar Tearing	Driscoll	<u>7</u>	<u>—</u>	<u>1</u>
47	J	Steel/Concrete Connections	Milek	<u>7</u>	<u>1</u>	<u>—</u>
47	K	Differential Movement of Columns	Khan	<u>6</u>	<u>2</u>	<u>—</u>
47	L	Mixed Construction	McGuire	<u>6</u>	<u>—</u>	<u>2</u>
47	M	Commentary for Tall Buildings	Higgins	<u>6</u>	<u>—</u>	<u>2</u>
47	N	Scope	Gaylord	<u>4</u>	<u>1</u>	<u>3</u>
47	O	Seismic Provisions	Driscoll	<u>4</u>	<u>2</u>	<u>2</u>

Name

Date