

Lehigh University Lehigh Preserve

Fritz Laboratory Reports

Civil and Environmental Engineering

1977

Analysis of stresses in superstructure of glenfield bridge over back channel, October 1977

J. H. Daniels

W. C. Herbein

H. T. Sutherland

Follow this and additional works at: <http://preserve.lehigh.edu/engr-civil-environmental-fritz-lab-reports>

Recommended Citation

Daniels, J. H.; Herbein, W. C.; and Sutherland, H. T., "Analysis of stresses in superstructure of glenfield bridge over back channel, October 1977" (1977). *Fritz Laboratory Reports*. Paper 2198.

<http://preserve.lehigh.edu/engr-civil-environmental-fritz-lab-reports/2198>

This Technical Report is brought to you for free and open access by the Civil and Environmental Engineering at Lehigh Preserve. It has been accepted for inclusion in Fritz Laboratory Reports by an authorized administrator of Lehigh Preserve. For more information, please contact preserve@lehigh.edu.

425/1/77

COMMONWEALTH OF PENNSYLVANIA
Department of Transportation
Bureau of Materials, Testing and Research

Leo D. Sandvig - Director
Wade L. Gramling - Research Engineer
Kenneth L. Heilman - Research Coordinator

Project 77-5: Evaluation of the Fracture of the Glenfield Bridge Girder

ANALYSIS OF STRESSES IN SUPERSTRUCTURE
OF GLENFIELD BRIDGE OVER BACK CHANNEL

FRITZ ENGINEERING
LABORATORY LIBRARY

by

J. Hartley Daniels

William C. Herbein

Hugh Sutherland

Prepared in cooperation with the Pennsylvania Department of Transportation and the U. S. Department of Transportation, Federal Highway Administration.

The contents of this report reflect the views of the authors who are responsible for the facts and the accuracy of the data presented herein. The contents do not necessarily reflect the official views or policies of the Pennsylvania Department of Transportation or the Federal Highway Administration. This report does not constitute a standard, specification, or regulation.

LEHIGH UNIVERSITY
Office of Research
Bethlehem, Pennsylvania
October 1977

Fritz Engineering Laboratory Report No. 425/1/77

ABSTRACT

This investigation reports the results of strain measurements made on the superstructure of the Glenfield Bridge on I79 near Pittsburgh, Pa., during the field splicing of the fractured fascia girder. The difference between splice plate force, as determined by strain gages, and the total jacking force can be attributed primarily to friction forces and to temperature effects. Because of friction between the splice plates and the flange, stress changes due to temperature fluctuations can occur in the splice plates at the fracture cross section without influencing the hydraulic pressure in the jacks. The measured stress distribution near the fracture cross section during the jacking operation shows excellent correlation with the results of a finite element analysis of the fractured girder.

TABLE OF CONTENTS

	<u>Page</u>
1. INTRODUCTION	1
1.1 Background	1
1.2 Objectives	3
1.3 Scope	4
2. INSTRUMENTATION AND RECORDING SYSTEM	6
2.1 Instrumentation of Bridge	6
2.2 Strain Recording System	6
3. RESULTS OBTAINED DURING JACKING OPERATION	8
3.1 Force in Splice Plates and Jack Force	8
3.2 Stress Distributions in Girders	10
3.2.1 Girder G4	10
3.2.2 Girders G2 and G3	10
3.3 Stresses in Other Members	11
4. ANALYSIS OF RESULTS	12
4.1 Comparison of Measured Splice Plate Force with Total Jack Force	12
4.2 Stress Distribution if Girders	14
4.2.1 Finite Element Model - G4	14
4.2.2 Girder G4	16
4.2.3 Girders G2 and G3	17
5. CONCLUSIONS	19
6. ACKNOWLEDGMENTS	20
7. TABLES AND FIGURES	21
8. REFERENCES	33

1. INTRODUCTION

1.1 Background

The I-79 Glenfield Bridge over the Ohio River back channel was opened to traffic on September 3, 1976. On January 28, 1977, the steel fascia, or outside, girder of the three-span continuous (226'-350'-226') superstructure carrying the northbound lanes over the back channel was observed to have fractured.⁽¹⁾ The crack had extended to the underside of the top flange before traffic was stopped from using the structure.

The fracture occurred at midpoint of the 350 ft center span (span 9) of the fascia girder (girder G4) as shown in Fig. 1. The superstructure consists of two main girders, G3 and G4, with transverse floor beam trusses spaced at 25 ft which support W24x68 stringers. The girders and stringers support an 8-1/2 in. noncomposite reinforced concrete slab. The adjacent superstructure carrying the southbound lanes also has two main girders, G1 and G2. The two superstructures are connected by trussed diaphragms which are designed to transmit live load between the structures.

At the fracture cross section girder G4 consists of an 11 ft x 1/2 in. web welded to 30 in. x 3-1/2 in. flanges. The web and flange plates are of A588 steel.

Subsequent inspections showed that the fracture had occurred at an electroslag weldment used to splice the tension flange of girder G4.

Inspection also revealed that the top flange of girder G4, in the vicinity of the fracture, had moved laterally to the east about an inch. This movement sheared off the narrow concrete fillet adjacent to the east edge of the top flange for a distance of 20 to 30 ft either side of the fracture cross section. The bottom flange had also moved laterally a small amount.

The girder was repaired by the installation of a bolted field splice on the web and tension flange after removal of a 30 in. x 60 in. segment of the girder. The web splice consists of two 126 in. x 55-1/2 in. plates. The tension flange splice consists of two top plates 14 ft 5-1/4 in. x 14 in. x 2-3/4 in. and one bottom plate 14 ft 5-1/4 in. x 30 in. x 2-3/4 in. The total area of the splice plates is 159.5 in.²

The field splice of girder G4 was installed in three main steps as follows:

- (1) The web and tension flange splice plates were bolted to the south side (Fig. 1) of the fracture cross section,
- (2) four 300-ton capacity horizontal hydraulic jacks anchored to the tension flange north of the fracture cross section (two on top, two below) near the unbolted ends of the tension flange splice plates, pulled on the flange splice plates with sufficient force to bring the bridge deck back to near original alignment and essentially restore the deadload bending moment distributions in girder G4, and
- (3) the remaining bolts in the web and tension flange splice plates were installed to complete the repair. (2)

During Step 2, the compression flange of girder G4 was also pulled slightly west to bring it back to its original position relative to the concrete slab in the vicinity of the fracture cross section.

Figure 2 shows the horizontal hydraulic jacking arrangement mounted to the tension flange of girder G4. The hydraulic jacks are shown to the right (north) of the figure. They react against an anchor block which is shown bolted to the tension flange several feet north of the fracture cross section. Large pullrods run from the jacks to the vertical pull plates just left of center of the figure. The pull plates are welded to the unbolted ends of the tension flange splice plates. The large nuts are on the south ends of the pull rods. The fracture cross section is out of view to the left. The "C" shaped plates joining the pullrods prevent the unbolted ends of the tension flange splice plates from deflecting away from the tension flange under the eccentrically applied jack loads.

1.2 Objectives

This report presents the results of strain measurements made on the tension flange splice plates, on several girder cross sections and on other members of the superstructure during the jacking operation.

The primary objectives of this investigation are to:

1. Provide an independent check during the jacking operation of the total force in the tension flange splice plates. The jacking operation was controlled by others using calibrated pressure gages,

2. Determine the incremental change in strain that was introduced into girders G2, G3, and G4 at four selected cross sections, during the jacking operation,
3. Determine the incremental change in strain that was introduced into certain floor beam truss members and certain bottom lateral bracing members, and to
4. Correlate the measured strain distributions with the predicted strain distributions obtained from mathematical models of the structure.

1.3 Scope

Strain measurements were acquired on March 16 and 17, 1977, at two cross sections of girder G4. Strains were also measured at one cross section each of girders G2 and G3, on several members of the floor beam truss immediately south of the fracture and on two members of the bottom lateral bracing system adjacent to the fracture. Measurements were made prior to starting the jacking operation and at several intermediate load levels up to restoration of the dead load bending moment in girder G4. Measurements were also made after high strength bolts were loosened in all floor beam-to-girder connections which showed overstress. Bolts were loosened at two intermediate stages of jacking.

Strain measurements were also acquired from the tension flange splice plates. The resulting total force in the splice plates was used to provide an independent check, during the jacking operation, of the jack loads as determined by others using calibrated pressure gages.

The measured strains are also compared with predicted strains provided by Richardson, Gordon and Associates.⁽³⁾ In addition, the measured strains in girder G4, adjacent to the fracture are compared to the predicted strains computed using the finite element program SAP IV.⁽⁴⁾ Both composite and noncomposite models were used in the finite element analysis.

2. INSTRUMENTATION AND RECORDING SYSTEM

2.1 Instrumentation of Bridge

Figure 3 shows the strain gages that were mounted on two cross sections of girder G4, on one cross section each of girders G2 and G3, on several members of the floor beam truss immediately south of the fracture, and on two members of the bottom lateral bracing system adjacent to the fracture. Strain gages were also mounted on the edges of the tension flange splice plates as shown in Fig. 4.

The gages used were 1/4 in., 120 ohm electrical resistance strain gages. They were mounted parallel to the direction of flexural stress in the girders and splice plates and parallel to the direction of axial stress in the floor beam truss members. A quarter-bridge, three-wire hookup was used, which automatically provides lead-wire and temperature compensation to all gages.

2.2 Strain Recording System

Signals from all strain gages were brought to switch boxes and an automatic self-balancing strain recorder located inside a van which was parked on the bridge deck. Figure 5 shows the instrumentation van which is parked on the west side of the bridge over girder G2. The arch span over the main channel, north of the back channel, can be seen in the background. The casualty girder, G4, is located under the east side of the bridge which is on the right side of Fig. 5. The van is located at

the intersection of girder G2 and gage section 1, which are shown in Fig. 3. A view of the switch boxes and self-balancing strain recorder is shown in Fig. 6.

3. RESULTS OBTAINED DURING JACKING OPERATION

3.1 Force in Splice Plates and Jack Force

The relationship between the computed force in the splice plates in kips (from measured strains) versus the closing displacement of the tension flange in inches, at the fracture cross section is shown in Fig. 7. The relationship between the total jack force as determined from calibrated pressure gages, versus the closing displacement of the flange is also shown in Fig. 7 for comparison. The flange was closed in increments of 1/4 in. until 1-1/4 in. relative closing displacement was reached. Then two additional increments were added until the total relative displacement reached 1-23/32 in.

The jacking operation commenced at 1:00 p.m., March 16, 1977. The air temperature was 52°F. Initial strain readings were taken at this time at all strain gage locations. When a 1/2 in. relative closing displacement was reached, some bolts at the west end of the floor beam truss just south of the fracture cross section were loosened. The force in the splice plates increased slightly (points S2 and S3, Fig. 7). The force at the hydraulic jacks however did not change (points J2 and J3). Additional bolts in the floor beam truss north of the fracture cross section were loosened next without any further change in the force in the splice plates or the hydraulic jacks. The compression flange of girder G4 near the fracture cross section was then pulled slightly west to align the girder.

When 1-3/8 in. displacement was reached (points S7 and J7) additional bolts were loosened on both floor beam trusses. Bolts were also loosened on the bottom lateral bracing members between girders G3 and G4 in the vicinity of the fracture cross section. The force in the splice plates increased (S7 to S8) while the jack force decreased (J7 to J8). The jack force was brought back to its original value (points J7 and J9). The force in the splice plates again increased slightly (point S9).

At this point, at 6:30 p.m. on March 16, 1977, the air temperature was 50°F. The jack force was then dropped to zero (J10) while lock nuts on the four pull rods maintained the tension in the splice plates (S10).

At 7:30 a.m., March 17, 1977, prior to increasing the jack force (J11), the force in the splice plates had increased 200 kips or 1.25 ksi (S10 to S11) due to an air temperature change from 50°F (S10) to 35°F. Such a change would be expected in a 3-span continuous structure as a result of the temperature differential between the concrete slab and the steel structure. At 9:50 a.m., March 17, 1977, the jack force was increased from zero until a slight movement of the tension flange was observed (J12). Unfortunately no corresponding measurement of the force in the splice plates was made. Thus, point S12 can not be shown in Fig. 7. At 10:00 a.m., March 17, 1977, the jack force was increased so that the original gap that existed between the fracture surfaces was eliminated. The resulting jack force is shown in Fig. 7 by point J13. The corresponding force in the splice plates is shown by point S13. At

this time the hydraulic jacks were retracted (J14). The tension in the splice plates was maintained by the four pull rods. At 12:00 noon, March 17, 1977, the final measurement of the splice plate force was made (S14). The measured force in the splice plates at this time (S14) was 1674 kips.

3.2 Stress Distributions in Girders

3.2.1 Girder G4

The measured stress distributions in girder G4 are shown in Fig. 8. Figure 8a shows the stress distributions on section 1 (Fig. 3) near the fracture cross section. The measured stress on each side of the girder at section 1 are plotted, and averaged to show the stress distribution in the girder (Solid Curves). Stress profiles are shown corresponding to splice plate forces of 685 (S3), 1305 (S5), and 1674 (S14) kips. The difference in the measured stress in the tension flange and at mid-depth is relatively small. However the difference is particularly apparent in the top flange where a transverse jack force was applied to align the girder as mentioned in Arts. 1.1 and 3.1. Figure 8b shows the stress distributions on section 2 (Fig. 3) at the same levels of splice plate forces. Note that two plotted points were available on the bottom flange, but only one each at mid-depth and on the compression flange.

3.2.2 Girders G2 and G3

The measured stress distributions in girders G2 and G3 are shown in Fig. 9. Figure 9a shows the stress distributions on section 1 (Fig. 3)

of girder G2 corresponding to splice plate forces of 685, 1305, and 1674 kips. Only one bottom flange stress level was recorded at 1674 kips because one of the two G2 bottom flange strain gages (Fig. 3) was out of commission at the completion of the jacking operation. Figure 9b shows the stress distributions on section 1 (Fig. 3) of girder G3 at the same levels of splice plate forces.

3.3 Stresses in Other Members

Table 1 shows the measured and computed strains and stresses in selected members of the floor beam truss and bottom lateral bracing system near the fracture cross section. (See Fig. 3 for location of strain gages.)

Columns 1 to 6 inclusive show the measured strains and computed stresses ($E = 29,500$ ksi) at each of six locations corresponding to measured splice plate forces of 685, 1305, 1674 kips. These levels of splice plate forces were selected so that the results shown in Table 1 would correlate with those given in Figs. 8 and 9.

Columns 7 to 10 inclusive give the strains and stresses predicted by Richardson, Gordon and Associates in Ref. 3. Reference 3 used a predicted total jack force of 1950 kips. The values given in Ref. 3 were modified assuming linear elastic behavior to show predicted strains and stresses at the measured 1674 kip level. Reference 3 assumed that the total jack force and the splice plate force would be equal.

4. ANALYSIS OF RESULTS

4.1 Comparison of Measured Splice Plate Force with Total Jack Force

It is evident from an examination of Fig. 7 that the splice plate force, as determined by strain gages (Fig. 4), does not completely agree with the total jack force as determined by calibrated pressure gages. The force in the splice plates is consistently lower whenever the jacks are under pressure and closing the tension flange.

Assuming that the calibrated pressure gages are accurate, there are three main reasons for the discrepancy:

1. The pull rods are eccentric to the splice plates as shown in Fig.
2. The large "C" shaped plates, connecting pairs of pull rods top and bottom, are designed to minimize separation between the splice plates and the tension flange under the "C" plate. It was observed during jacking, however, that both "C" plates distorted and opened up. It was apparent that the splice plates were bending and that a compressive force was being developed between the ends of the splice plates (just left of the anchor block bolted to the tension flange as shown in Fig. 2) and the tension flange. A lubricant placed on the surfaces of the splice plates to relieve the resulting friction forces was ground off prior to jacking.

It is believed that substantial friction forces were developed at the ends of the splice plates, resulting in higher

jack forces. This conclusion is supported by the behavior at 1/2 in. displacement shown in Fig. 7. When bolts were loosened in the floor beam truss, the force in the splice plates increased slightly as shown by points S2 and S3. An increase in splice plate force would be expected due to a reduction in torsional restraint to girder G4 upon loosening the bolts. The jack force did not change (J2 and J3). This would be expected if frictional forces developed between the splice plate gages and the hydraulic jacks.

In addition, at 1-3/8 in. displacement (Fig. 7), when the jack force was increased from J8 to J9 to bring the jack force to the same level as J7, the force in the splice plates increased only about one-third as much, which would be consistent with an assumption of friction forces developing.

Referring to Fig. 7, it is unlikely that relative tension flange displacement began with nearly zero jack loads as shown. Although no confirming data exists, it is more likely that, due to friction, the jack loads reached 100 to 200 kips before flange displacement was observed. Thus the vertical difference between the two curves in Fig. 7 varies from about 200 kips at low displacement to about 400 kips at the higher displacements. This difference can be explained by the presence of friction forces at the ends of the splice plates which increase as the jack loads and bending of the splice plates increase.

2. The strain gages on the splice plates (Fig. 4) were placed in the field. The splice plates were not calibrated, thus some inaccuracy is possible in the measurement of the splice plate forces. However, errors were minimized by placing four gages on the edges of each splice plate and averaging the readings at each displacement increment.
3. Differential temperature conditions between the concrete slab and the steel superstructure also introduces stresses into the 3-span continuous structure. This is particularly noticeable from the differences between the splice plate force at S10 and S11. As noted this measured increase was observed over a thirteen-hour period (6:30 p.m. to 7:30 a.m.) when the air temperature decreased by 15°F. Measurements during June 1977 further confirmed these observations.

4.2 Stress Distribution in Girders

4.2.1 Finite Element Model - G4

Figure 10 shows the finite element (FE) model used to determine the stress distribution on section 1 of girder G4. A portion of girder G4, south of the fracture cross section, was selected for modeling. The web of girder G4 is modeled by 320 plane stress elements while 64 truss or bar elements model the top and bottom flanges. The horizontal roller support at the fracture cross section accounts for the continuity of the steel top flange and concrete slab above the fracture location. The two vertical roller supports are arbitrarily located sufficiently distant from section 1 so as to have a negligible effect on the stress

distribution at section 1 which lies in a region of constant bending moment.

Figure 10b is an enlargement of the shaded area in Fig. 10a and shows the distribution of bolt forces applied to the girder. The bolt forces were applied by the flange splice plates during jacking. They are consistent with the final measured 1674 kip force in the splice plates rather than the assumed 1950 kip jacking force which was used in the splice plate analysis of Ref. 2.

The FE model of girder G4 was used to analyze three different cross sections: (1) the steel girder alone; (2) composite section consisting of steel girder and 8-1/2 ft wide slab; and, (3) composite section consisting of steel girder and 22 ft wide slab. To simplify the analysis, the transformed concrete areas of the composite sections were included in the areas of the top flange elements with no modification of the depth of the cross section. This simplification is not expected to have a significant affect on the analysis.

Figure 11 shows the two composite cross sections which were used in the FE analysis. The smaller cross section was selected to agree with Ref. 3 which used an 8 ft-6 in. slab together with a modular ratio, n , of 10 in predicting strains at sections 1 and 2 of girder G4 (Fig. 3) under composite action. The 22 ft slab width was selected to represent one-half the concrete roadway between girders G3 and G4 and to include the mass of concrete forming the railing wall shown on the right side of Fig. 5. A modular ratio of 8, corresponding to 4000 psi concrete, was used in transforming the 22 ft wide slab.

4.2.2 Girder G4

The three stress profiles obtained from the FE analysis for section 1 of girder G4 are plotted in Fig. 8a. Good agreement is obtained between the FE analysis using the 22 ft wide slab and the measured stress distribution under the 1674 kip force in the splice plates. The FE analyses using the 8 ft-6 in. slab width and for the steel girder alone differ greatly from the measured stress profile above the neutral axis. Although the bridge superstructure is noncomposite, the response of girder G4 during the jacking operation indicates that nearly full composite action existed between the steel girder and concrete slab throughout the jacking operation.

The measured stress profiles in Fig. 8a are fitted to the average stresses recorded by the three pairs of strain gages on section 1 of G4 as discussed in Art. 3.2.1. Under ideal plane bending conditions the flexural stresses obtained from the individual strain gages in a pair of gages would be equal. The stresses plotted in Fig. 8a show a spread of up to 5 ksi for the pair of gages on the top flange. A smaller difference exists in the bottom flange. The difference can be attributed mainly to lateral bending of the top flange during the jacking operation. As mentioned earlier lateral bending was introduced while pulling the compression flange of girder G4 west to bring it to its original position relative to the concrete slab in the vicinity of the fracture cross section. In addition the tension flange would move laterally as it realigned under the applied jack loads.

The pair of strain gages on the bottom flange at section 2 of girder G4 also exhibit a smaller stress differential which also can be attributed to lateral bending. The single strain gages on the web and top flange at section 2 do not permit an averaging of the measured stresses. Thus, the measured stress profiles shown in Fig. 8b are unable to completely account for the lateral bending of girder G4. No FE analysis was performed for section 2.

Figures 8a and 8b also include predicted stress profiles from Ref. 3 based upon an expected total jacking force of 1950 kips. The values given in Ref. 3 were also modified to show predicted stress profiles at the 1674 kip level. The composite section used in Ref. 3 included a slab width of 8-1/2 ft (Fig. 11).

4.2.3 Girders G2 and G3

The measured stress profiles at section 1 of girders G2 and G3 are presented in Figs. 9a and 9b. The stress differential across the bottom flange of each girder is believed due to lateral bending caused by alignment of girder G4 during the jacking operation. Since single gages were placed on the webs and top flange the average flexural stress at these locations cannot be obtained. Only one bottom flange strain gage on girder G2 was operational at the 1674 kip load level.

Figures 9a and 9b also include predicted stress profiles from Ref. 3 based upon an expected total jacking force of 1950 kips. The values given in Ref. 3 were also modified to show predicted stress

profiles also at the 1674 kip level. The composite section used in Ref. 3 included a slab width of 8-1/2 ft (Fig. 11).

The measured top flange stresses shown in Fig. 9a and 9b are less than stresses predicted on the basis of composite action using the 8-1/2 ft slab width. Thus, the amount of concrete contributing to the composite action of girders G2 and G3 was obviously greater than the 8-1/2 ft width assumed in Ref. 3, appears closer to the 22 ft slab (half-width) assumed in the FE analysis of girder G4.

5. CONCLUSIONS

During the jacking operation, the measurement of the forces in the tension flange splice plates provided an independent check of the total jacking force. The difference between the measured splice plate force and the hydraulic jack force is attributed primarily to friction forces and to temperature effects. Because of friction between the splice plates and the flange, stress changes due to temperature fluctuations can occur in the splice plates at the fracture cross section without influencing the hydraulic pressure in the jacks.

The strains in three of the four main girders of the bridge and in selected floor beam truss members and bottom lateral bracing members were recorded during the jacking operation. The measured stress distribution in the fascia girder near the fracture cross section shows excellent agreement with a finite element analysis of the girder under the jacking forces applied.

6. ACKNOWLEDGMENTS

This investigation is part of a research project being conducted in the Department of Civil Engineering and Fritz Engineering Laboratory, Lehigh University, Bethlehem, Pennsylvania. Dr. Lynn S. Beedle is the Director of Fritz Engineering Laboratory, and Dr. David A. VanHorn is Chairman of the Department of Civil Engineering. Dr. John W. Fisher is Director of the project sponsored by the Pennsylvania Department of Transportation (PennDOT) and the U. S. Department of Transportation, Federal Highway Administration (FHWA).

The assistance of PennDOT personnel and Fritz Engineering Laboratory staff members is greatly appreciated.

7. TABLES AND FIGURES

Table 1 Measured and Computed Strains and Stresses in Selected Members of the Floor Beam Truss and Bottom Lateral Bracing System

Jacking Force →	Measured						Ref. 3			
	685 kips		1305 kips		1674 kips		1674 kips		1950 kips	
	ϵ $\mu\text{in/in}$	σ ksi	ϵ $\mu\text{in/in}$	σ ksi	ϵ $\mu\text{in/in}$	σ ksi	ϵ $\mu\text{in/in}$	σ ksi	ϵ $\mu\text{in/in}$	σ ksi
Location	(1)	(2)	(3)	(4)	(5)	(6)	(7)	(8)	(9)	(10)
a	- 64	-1.9	-176	- 5.2	-252	- 7.4	- 630	-18.6	- 734	-21.7
b	+175	+5.2	+337	+ 9.9	+372	+11.0	+1186	+35.0	+1381	+40.7
c	+ 15	+0.4	+ 51	+ 1.5	- 68	- 2.0	+ 87	+ 2.6	+ 101	+ 3.0
d	+296	+8.7	+582	+17.2	+830	+24.5	+1241	+36.6	+1446	+42.7
e	+225	+6.6	+446	+13.2	+670	+19.8	+622	+18.3	+ 725	+21.4
f	-116	- 3.4	-182	- 5.4	-238	- 7.0	-	-	-	-

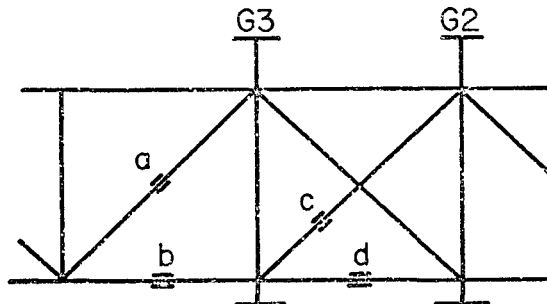

Elevation of Floor Beam Truss (Sect ① Fig. 3)

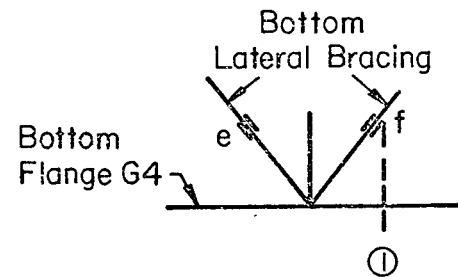

Plan of Bottom Lateral Bracing (Fig. 3)

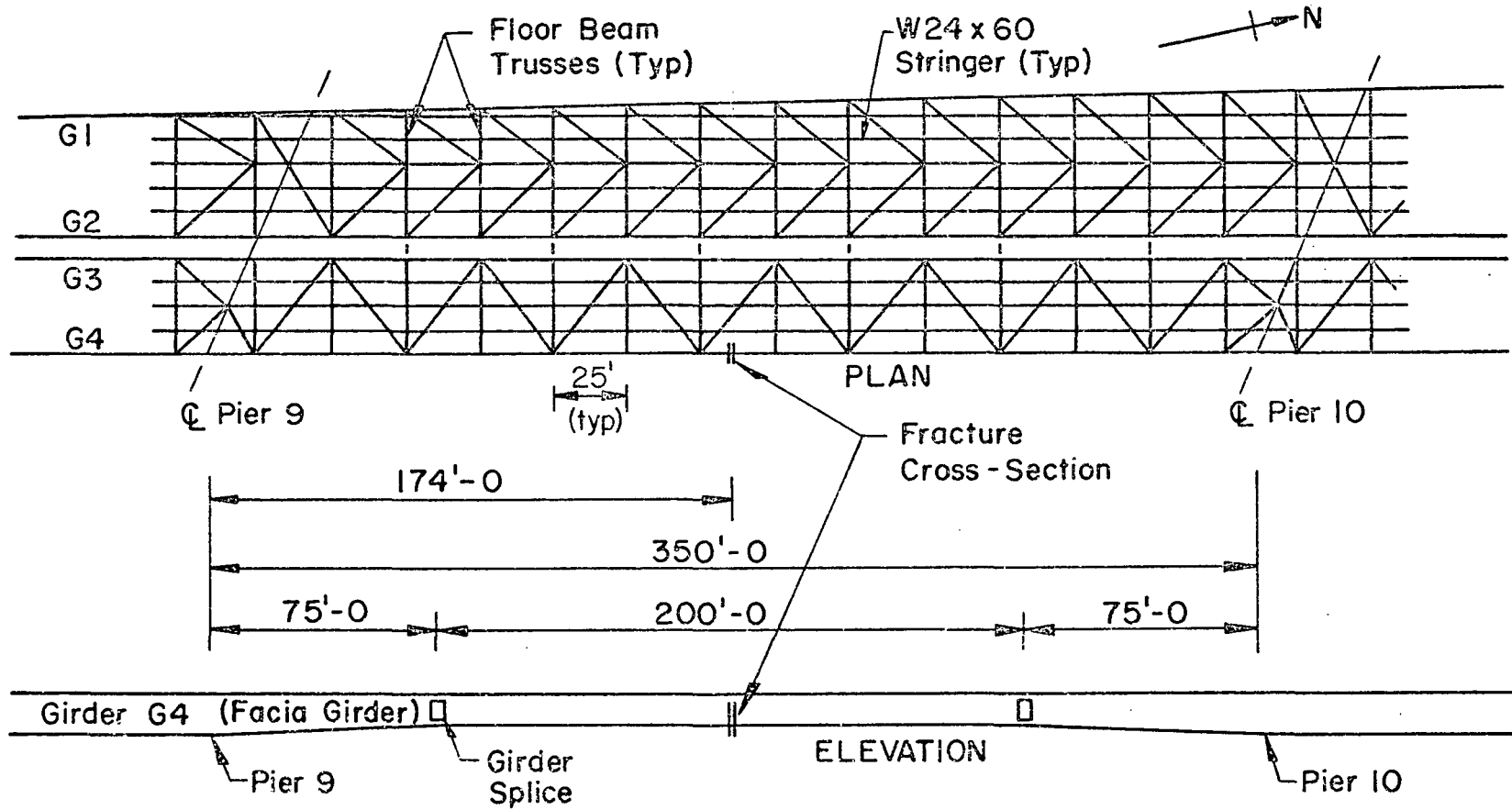

Fig. 1 Plan and Elevation of 350 ft Center Span

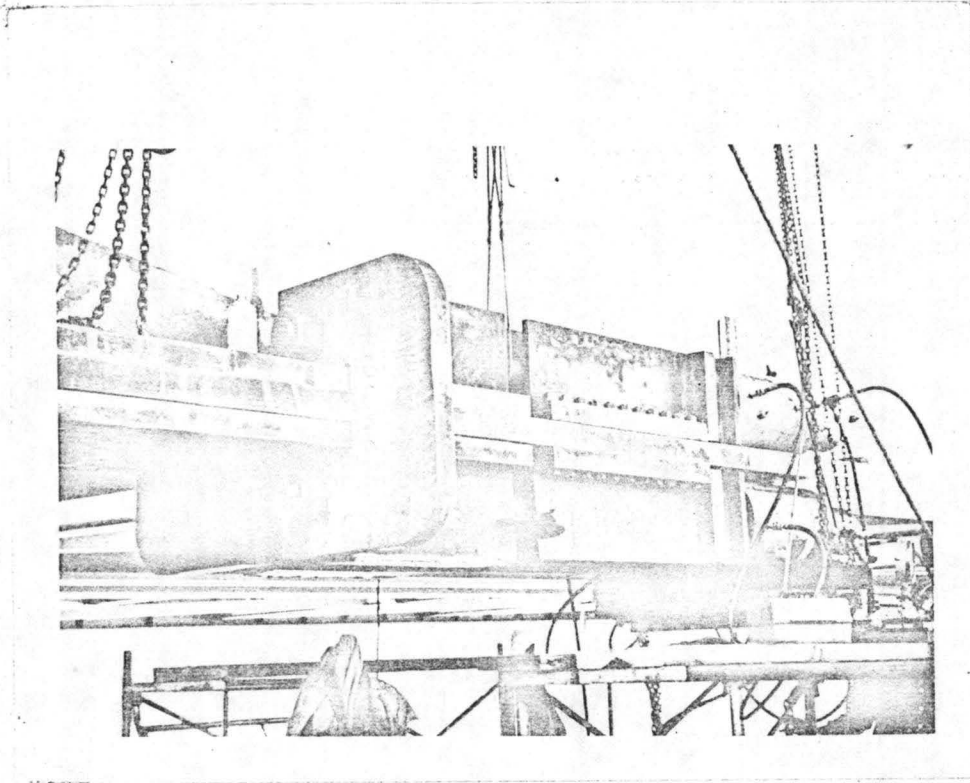

Fig. 2 Horizontal Hydraulic Jacking Arrangement Mounted on Tension Flange of Girder G4

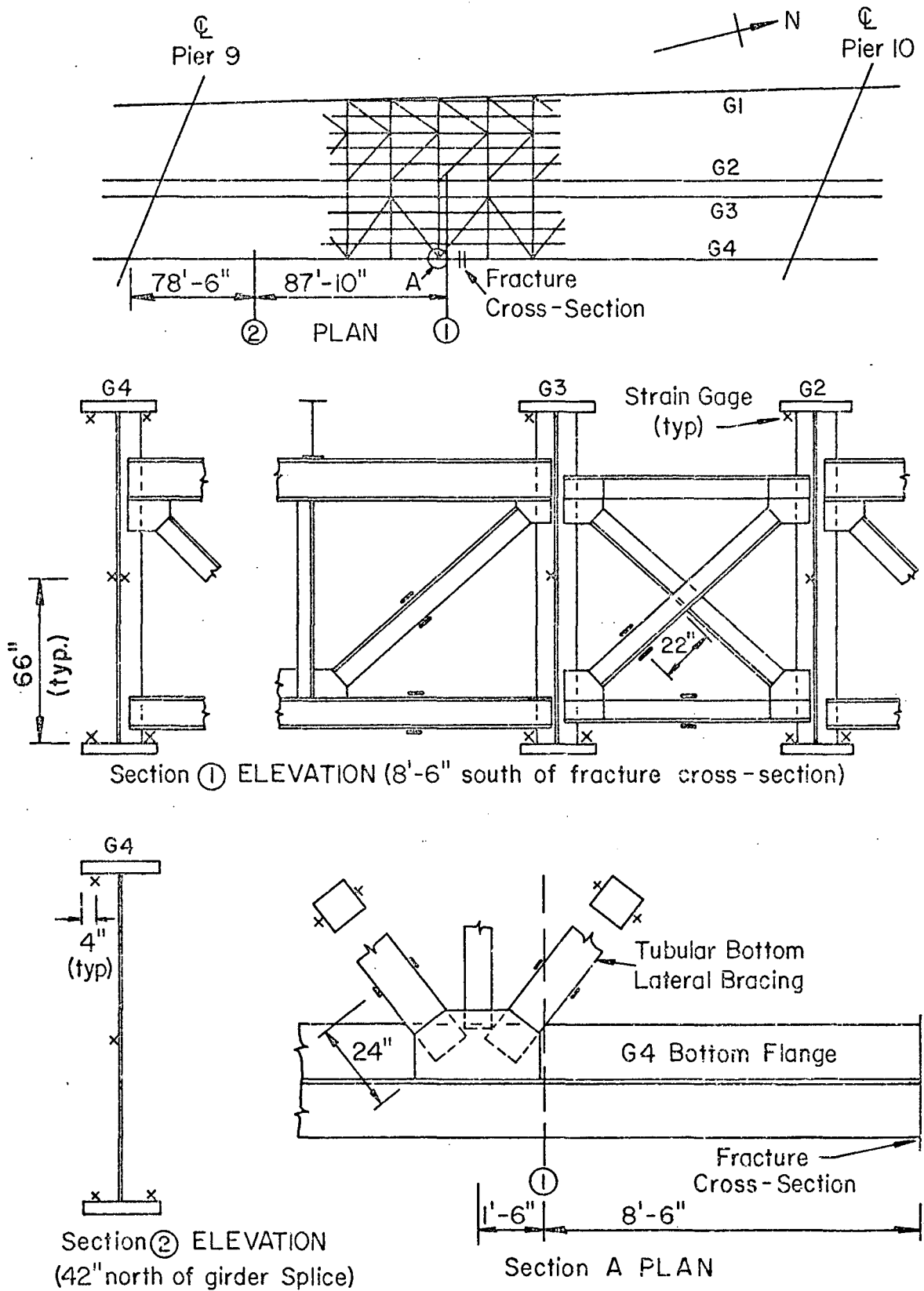
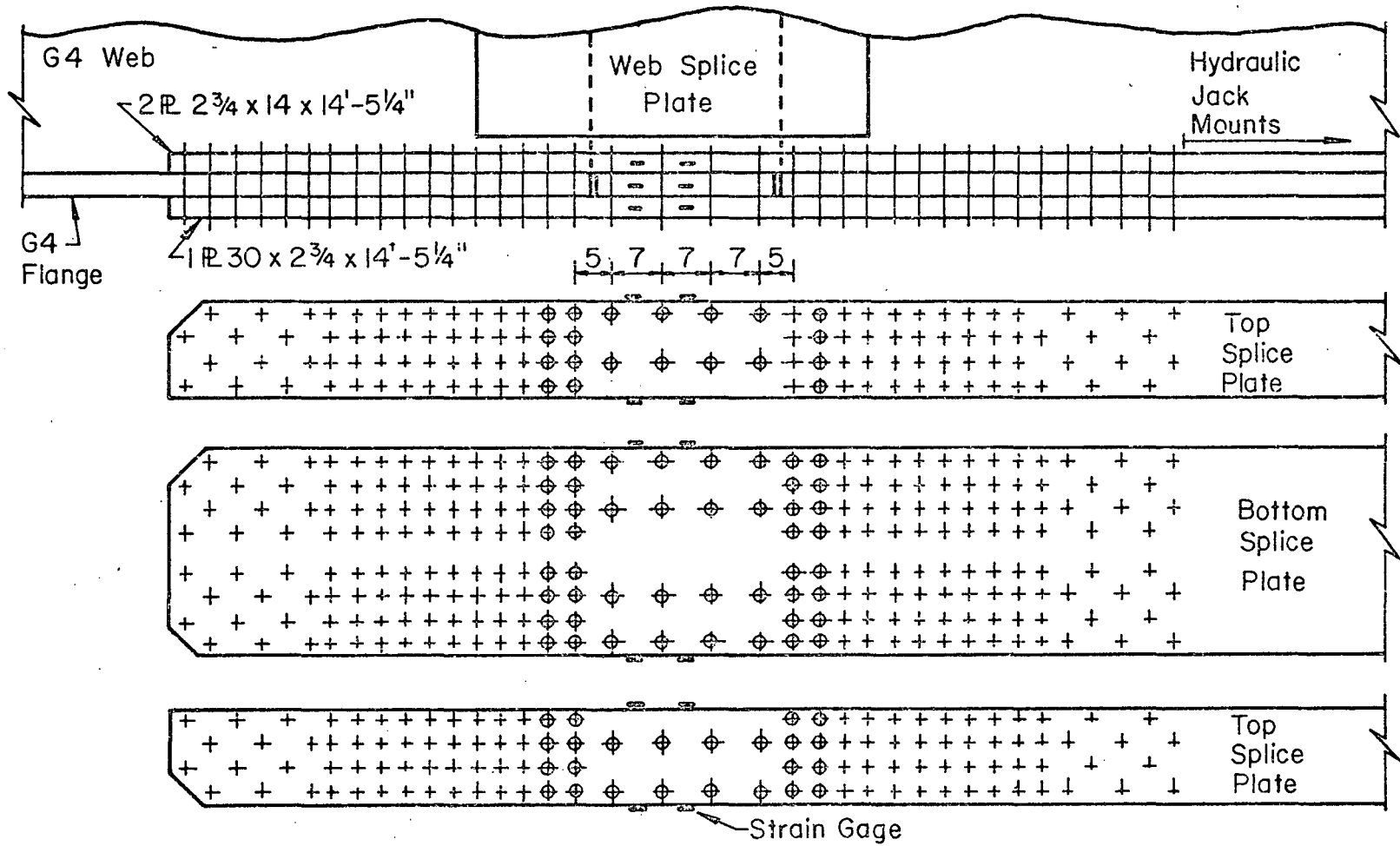

Fig. 3 Instrumentation of Bridge Members



-26-

Fig. 4 Instrumentation of Splice Plates

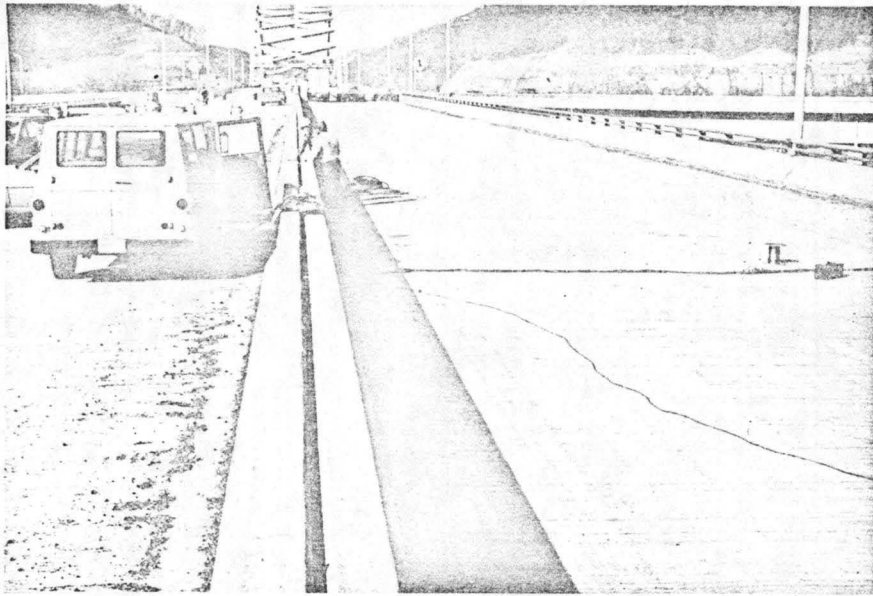

Fig. 5 Instrumentation Van Parked on West Side of Bridge (Over girder G2)

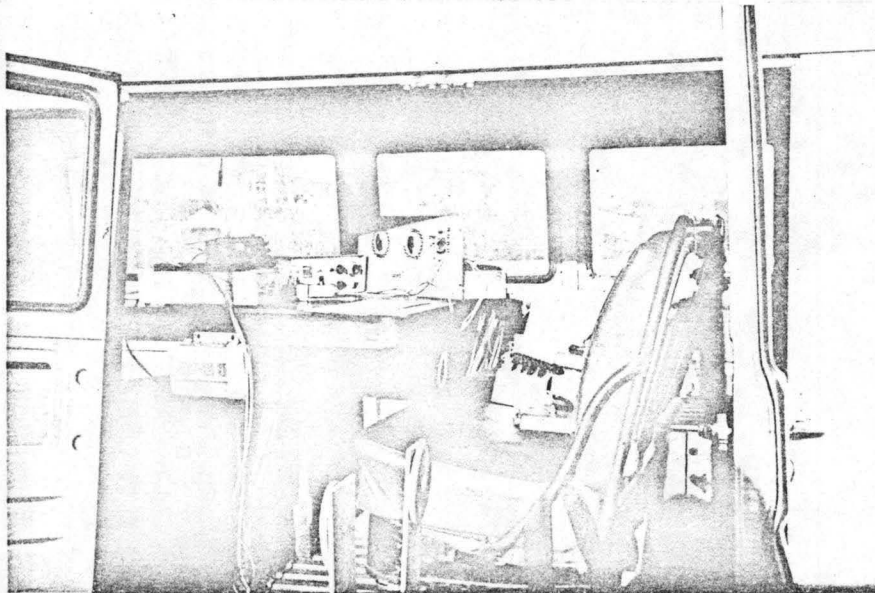

Fig. 6 Switch Boxes and Self-balancing Strain Recorder Inside Instrumentation Van

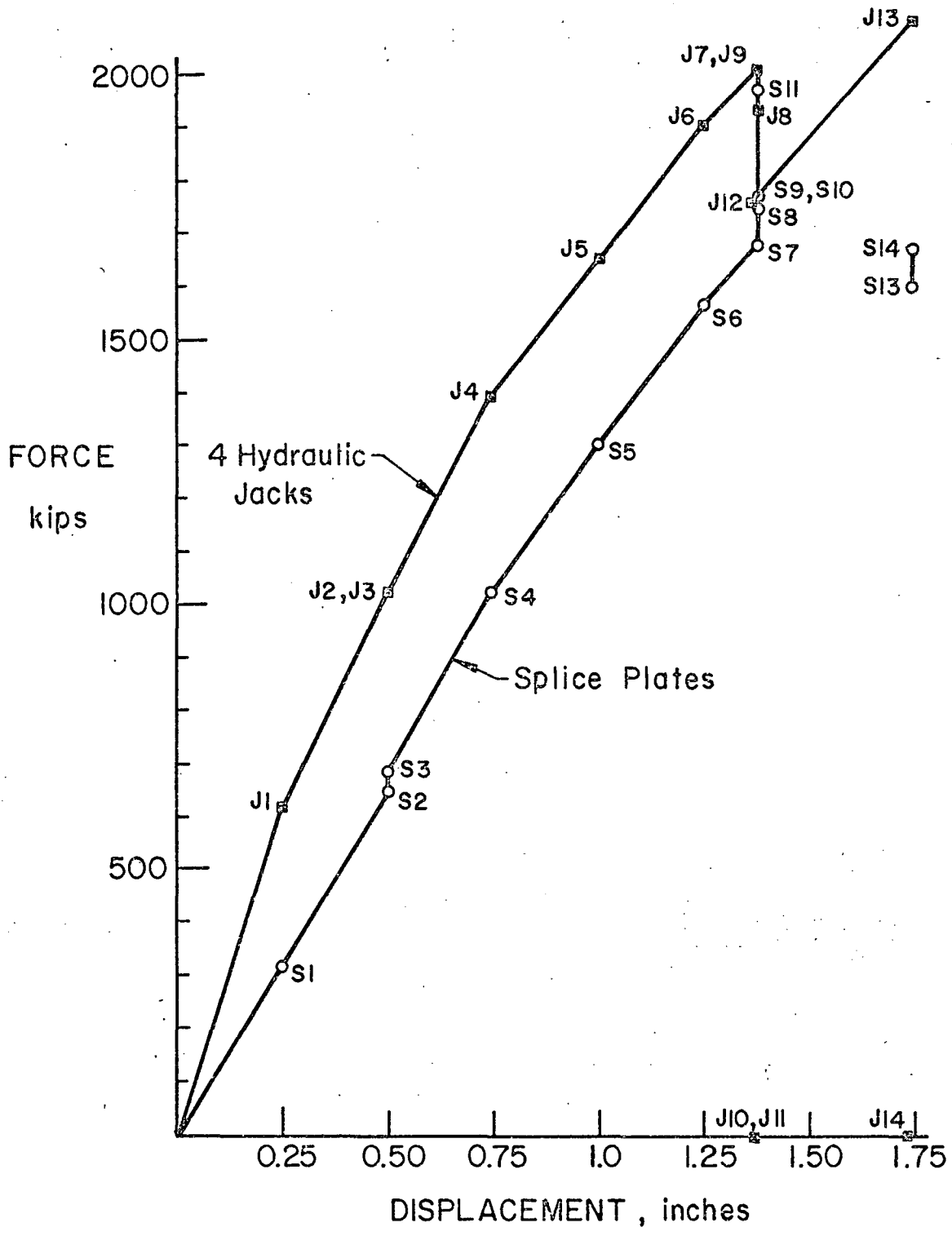

Fig. 7 Relationship between Measured Force in Splice Plates and Force in Hydraulic Jacks versus the Relative Closing Displacement of the Tension Flange

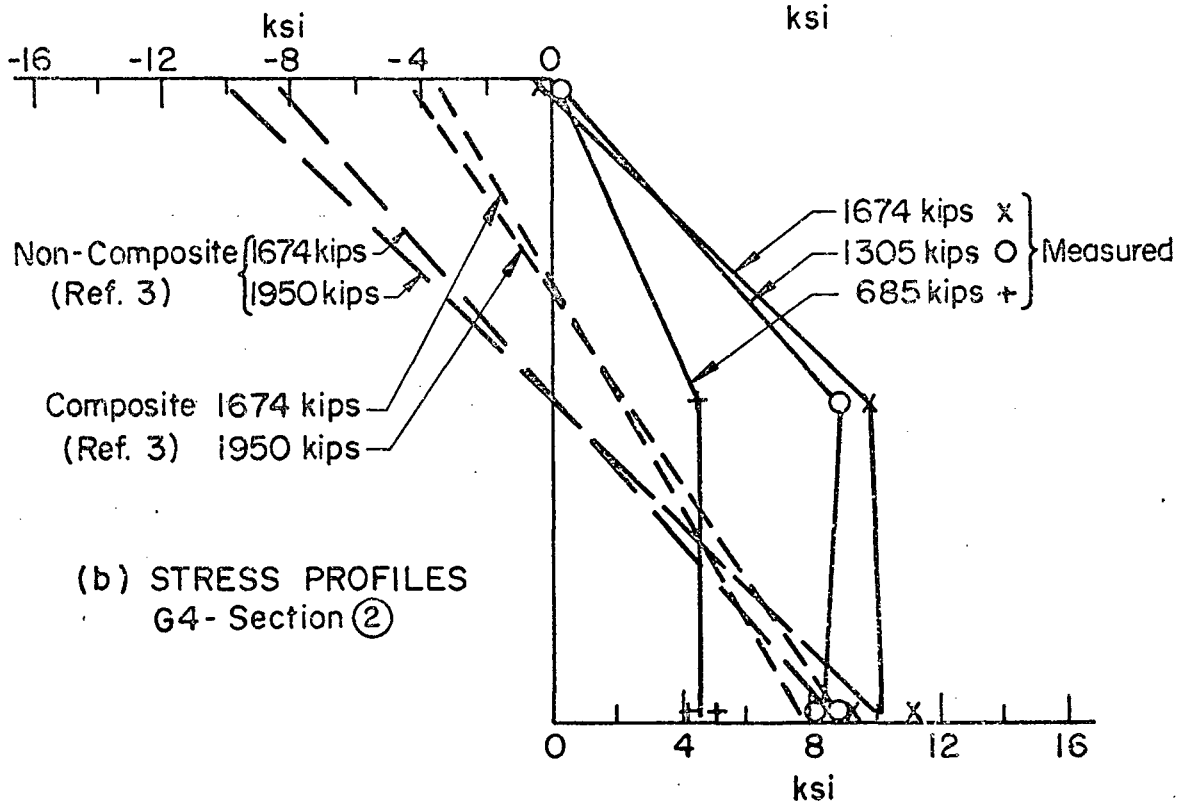
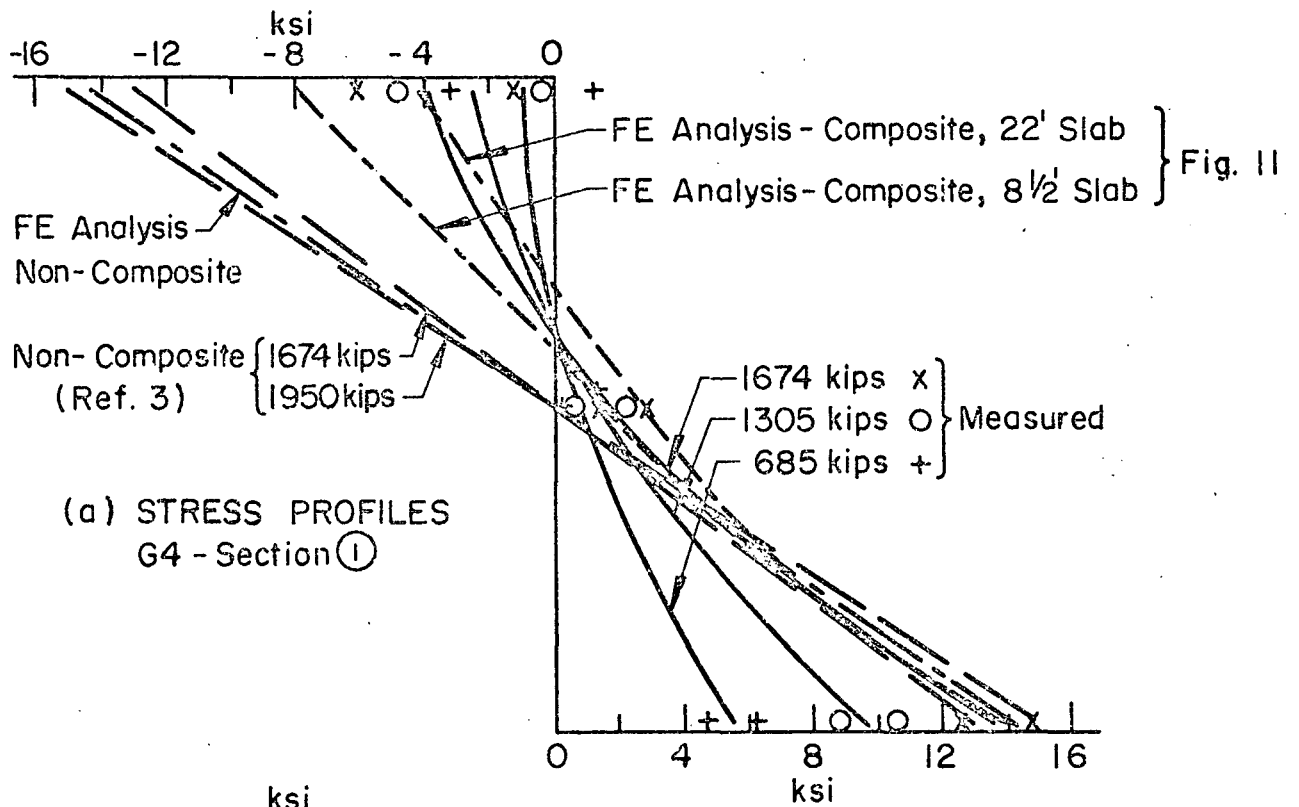

Fig. 8 Stress Distribution in Girder G4

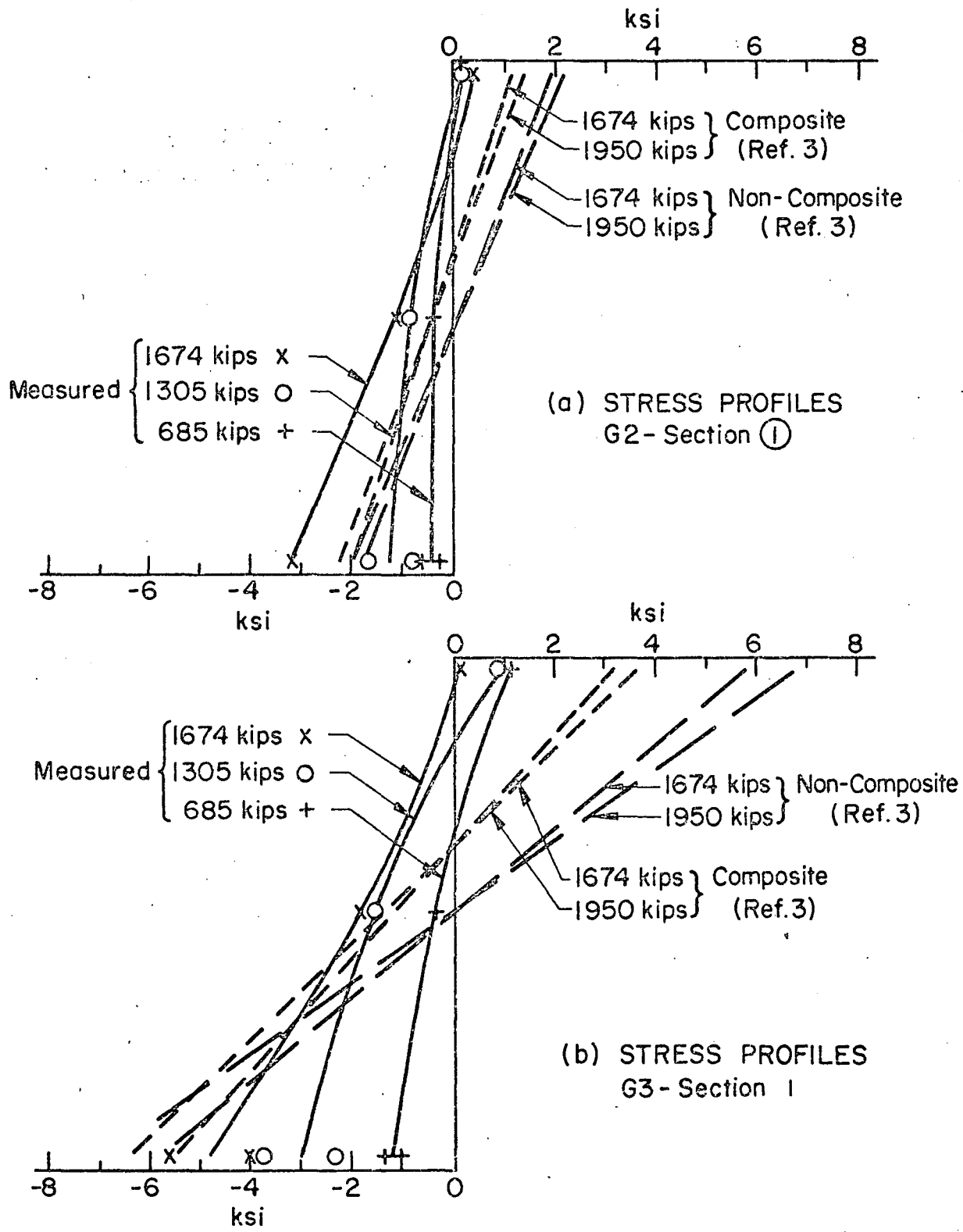

Fig. 9 Stress Distributions in Girders G2 and G3

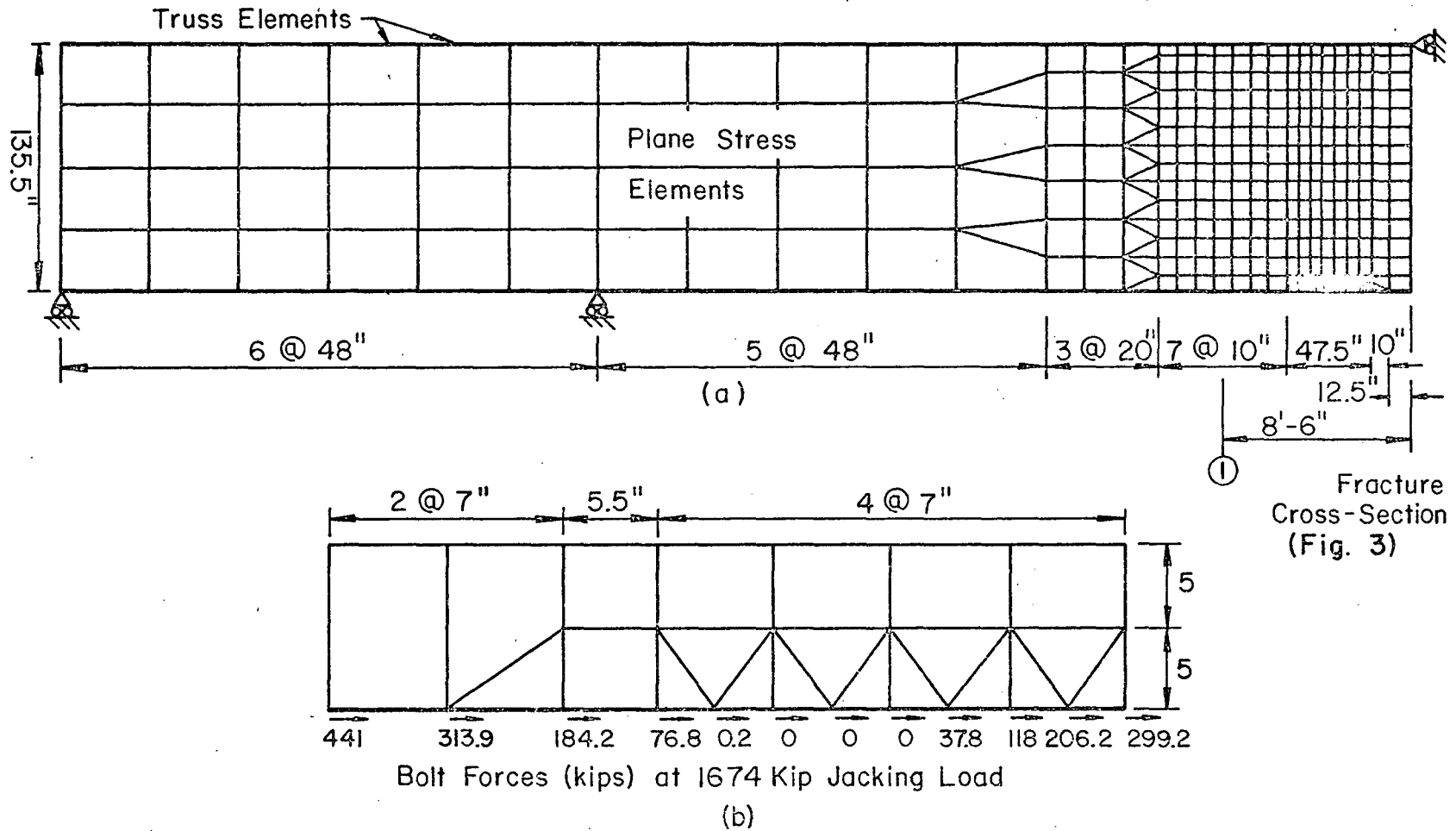

Fig. 10 Finite Element Model of Girder G4 South of Fracture Cross Section

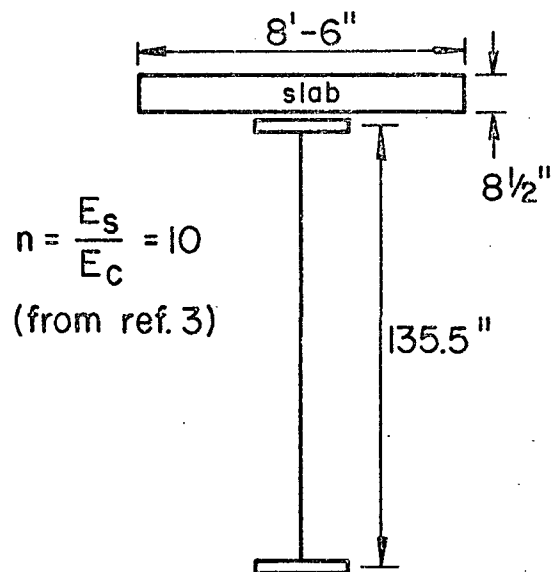
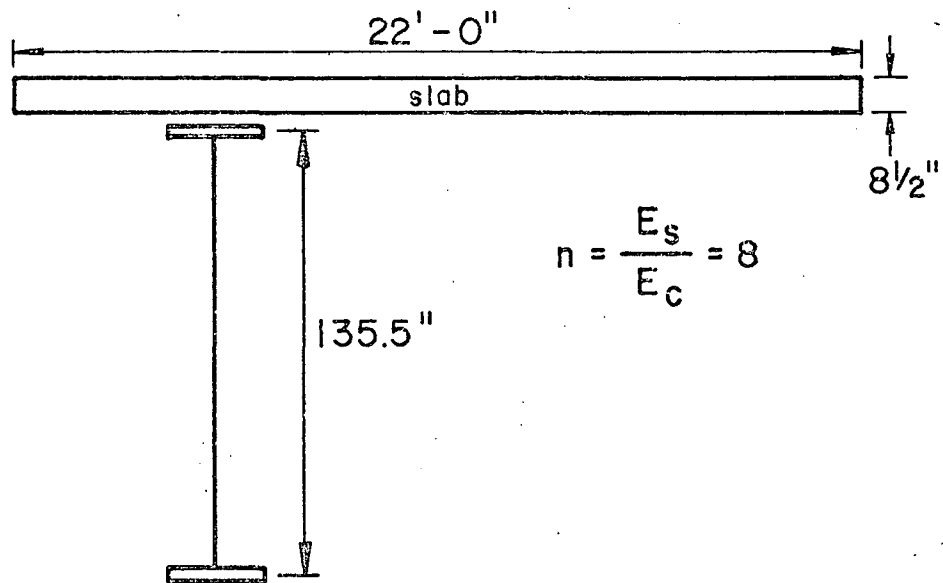

Fig. 11 Composite Girder Cross Section Used
in Finite Element Analysis

8. REFERENCES

1. CRACKED GIRDER CLOSES I-79 BRIDGE
Engineering News-Record, February 10, 1977, p. 11.
2. Richardson, Gordon, & Associates
ELASTIC-PLASTIC ANALYSIS OF GIRDER G-4 REPAIR, Report on Allegheny County L.R. 1016, Section 11E, Neville Island Bridge, March 1977.
3. Richardson, Gordon, & Associates
Letter to Dr. John W. Fisher, Lehigh University, Fritz Engineering Laboratory from Louis P. Schwendeman, dated March 1, 1977.
4. Bathe, K. J., Wilson, E. L., and Peterson, F. E.
SAP IV, A STRUCTURAL ANALYSIS PROGRAM FOR STATIC AND DYNAMIC RESPONSE OF LINEAR SYSTEMS, Earthquake Engineering Research Center, Report No. EERC 73-11, University of California, Berkeley, California, June 1973, revised April 1974.