

1961

Apparatus for testing plate panels under axial and lateral loading, Lehigh University, (June 1961)

A. Ostapenko

Follow this and additional works at: <http://preserve.lehigh.edu/engr-civil-environmental-fritz-lab-reports>

Recommended Citation

Ostapenko, A., "Apparatus for testing plate panels under axial and lateral loading, Lehigh University, (June 1961)" (1961). *Fritz Laboratory Reports*. Paper 1676.
<http://preserve.lehigh.edu/engr-civil-environmental-fritz-lab-reports/1676>

This Technical Report is brought to you for free and open access by the Civil and Environmental Engineering at Lehigh Preserve. It has been accepted for inclusion in Fritz Laboratory Reports by an authorized administrator of Lehigh Preserve. For more information, please contact preserve@lehigh.edu.

APPARATUS FOR TESTING PLATE
PANELS UNDER AXIAL
AND LATERAL LOADING

"In the course of an investigation into the strength of ship bottom plating a special apparatus was designed to test longitudinally stiffened plate panels by subjecting them to combined axial and lateral loading."

by

Alexis Ostapenko

June 1961

248.6

T A B L E O F C O N T E N T S

	Page
A B S T R A C T	1
1. I N T R O D U C T I O N	2
2. D E S C R I P T I O N O F A P P A R A T U S	
2.1 R E Q U I R E M E N T S A N D G E N E R A L A R R A N G E M E N T	4
2.2 E N D F I X T U R E S	6
2.3 L A T E R A L L O A D I N G S Y S T E M	
2.3.1 P a r t s a n d F u n c t i o n s	8
2.3.2 P r e s s u r e C o n t r o l s	8
2.3.3 P r e s s u r e B o x	9
2.4 B R A C I N G	11
2.5 I N S T R U M E N T A T I O N	11
2.5.1 D i a l G a g e s	12
2.5.2 S t r a i n G a g e s	13
2.6 A L I G N M E N T	13
3. D I S C U S S I O N	14
4. A C K N O W L E D G E M E N T S	16
5. B I B L I O G R A P H Y	18
6. L I S T O F C A P T I O N S	19
7. F I G U R E S	20

APPARATUS FOR TESTING PLATE
PANELS UNDER AXIAL AND
LATERAL LOADING

"In the course of an investigation into the strength of ship bottom plating a special apparatus was designed to test longitudinally stiffened plate panels by subjecting them to combined axial and lateral loading."

by Alexis Ostapenko

Associate Professor of Civil Engineering
Fritz Engineering Laboratory
Lehigh University
Bethlehem, Pennsylvania

A B S T R A C T

A description of an apparatus for testing longitudinally stiffened plate panels subjected simultaneously to lateral and axial loading is presented. The apparatus was designed to apply axial compression of a maximum of 1,000,000 lb. and uniformly distributed lateral pressure of a maximum of 13.0 psi; a 5,000,000 lb. universal testing machine and a special compressed air system, respectively, were used for this purpose. This paper is primarily concerned with a description of the compressed air system, since it is the most important part of the apparatus. The test specimens were made as one-to-four scale models of ship bottom plating and had overall dimensions of 51 in. by 61 in. The boundary conditions were accurately defined - the axially loaded edges were pin-ended and the unloaded

edges were free. The instrumentation consisted of dial gages and electric-resistance strain gages to supply a reasonably complete picture of the behavior of specimens during testing. The performance of the apparatus was found very satisfactory.

1. I N T R O D U C T I O N

In the course of an investigation into the strength of longitudinally stiffened plate panels it was necessary to test such panels by subjecting them simultaneously to lateral and axial loading under specific boundary conditions (1)*. Some tests of this nature have been carried out in the past, for example, by McPherson, Levy and Zibritosky (2), but the test arrangements used were not suitable for the purpose of the present research - they either were small in size and had low capacity or had rather indefinite boundary conditions. The apparatus designed by the author and described in this paper appears to be the first in literature to fulfill the requirements regarding the capacity and the boundary conditions needed in this research.

Longitudinally stiffened panels are used in the bottom plating of ships with longitudinal framing. The severest loading condition occurs when a panel is subjected to lateral

* Numbers in parentheses pertain to references in bibliography at end of paper.

hydrostatic pressure and axial compression due to wave action (hogging). Fig. 1 is a sketch of a typical bottom panel showing these forces acting on it. Panels in an actual ship structure are continuous at the transverse ribs. For an initial investigation, however, it was advantageous to simplify the boundary conditions to simply supported loaded edges and free side edges. The test specimens were proportioned as one-to-four scale models of actual ship bottom plating and had overall dimensions of 51 in. width by 61 in. length, as shown in Fig. 2. The maximum loads expected during testing were 1,000,000 lb. axial compression and 13.0 psi lateral pressure.

As the first step during testing, lateral pressure on a specimen was raised to full intensity. Then, the axial load was gradually increased till it reached its ultimate magnitude. The test was concluded by unloading the specimen.

The apparatus consisted basically of two functionally independent systems: one for the application of lateral pressure, and the other for the application of axial load. A schematic picture of the apparatus is shown in Fig. 3. The general operation of it was as follows: Compressed air passing through a system of controlling valves and a mercury manometer entered the pressure box and exerted lateral pressure on the specimen; axial force was applied to the specimen through special end fixtures by means of a universal testing machine.

Strains and deformations of specimens were measured using strain and dial gages, respectively.

2. DESCRIPTION OF APPARATUS

2.1 REQUIREMENTS AND GENERAL ARRANGEMENT

The design of the apparatus was guided by the following requirements:

- a) Boundary Conditions. The loaded ends of the test specimen should be pin-ended and the side edges - free. The specimen should in no way be restrained from deforming freely.
- b) Capacity. The apparatus should be capable of applying, simultaneously, a maximum lateral loading of 13.0 psi and an axial force up to 1,000,000 lb.
- c) Loading Conditions. The apparatus should be in a state of self-equilibrium during the application of lateral loading.

Axial load was applied to the specimen by means of a 5,000,000 lb. Baldwin-Southwark universal testing machine, and uniform lateral loading was supplied by a specially designed compressed air system.

A schematic presentation of the loading system and its major components is given in Fig. 3; this figure aids in grasping the operation of the apparatus. The more elaborate

Fig. 4 illustrates the construction of the apparatus in detail. The axial load is transmitted from the testing machine to the specimen through the end fixtures, which furnish pin-ended conditions. The specimen is bolted to the top and bottom end blocks which are part of the end fixtures. Uniform lateral loading is applied to the specimen by means of a pressure box which is connected to the end blocks by four links at the corners and which stands on the machine pedestal on four adjustable vertical supports. With the test specimen as a front wall, the pressure box forms a complete enclosure. Lateral pressure is exerted on the back side of the specimen by compressed air contained in an inner cell which forms an impermeable lining inside the pressure box enclosure. The pressure is regulated manually through a combination of a mercury manometer and two valves.

The general arrangement of the test setup and instrumentation is shown in Fig. 5. In the center is the test specimen standing upright between the pedestal and the machine crosshead. The specimen, which is colored white, is somewhat obscured by the dark dial gage frame that is attached to the pedestal in front of the specimen. To the left is the compressed air bottle and a stand on small wheels which supports the pressure controls. The black rubber hose leading from the top of the stand to the back of the specimen supplies compressed air to the pressure box. On the right

side, the electric-resistance strain gage reading instruments are grouped: the automatic strain reader, Digitizer, and two conventional strain indicators with switch boxes. A side view of the test assembly on top of the machine pedestal (the pedestal can be jacked up and rolled on the floor) can be seen in Fig. 6.

A detailed description of the individual parts, their design and functions is given in the following sections.

2.2 END FIXTURES

Pin-ended condition for the specimen ends was achieved by means of two sets of end fixtures each composed of an end block, a cylindrical bearing bar, and a platen. These elements are shown separately in the exploded view of the pressure box in Fig. 7. The end fixtures in their assembled position can be seen in Figs. 3, 4, 6 and 8. The pin-ended condition (the free rotation of the specimen end) is created by the rolling of the cylindrical bearing bar on the flat surface of the platen. The center of the circular bearing surface is made coincident with the center of the link pin which is at the mid-height of the end block. The center of gravity of the specimen also passes through this point. With such an arrangement, the line of action of the axial force will always go through the same fixed point, that is, the center of the link pin which is then the theoretical "pin". The effective length of the specimen is the distance between the "pins", or the mid-heights of the end blocks as shown in Fig. 2.

The test specimens were connected to the end blocks by bolts. The connection had to be strong enough to transmit the shearing force between the specimen and the end block, resulting from lateral pressure. The bolted connection also facilitated changing of the specimens.

The dimensions of the end blocks were controlled by their deflection under the effect of lateral loading; an end block was in effect spanning between the two links at its ends.

The contact surfaces of the platen and the cylindrical bearing bar were heat treated to have very high yield point (about 250,000 psi, Brinell Hardness Number about 420) so that the applied axial load would be transmitted by the line of contact without causing yielding of the material. Hertz' formula was used to determine the necessary radius of curvature of the contact surface.

The cylindrical bearing bar was aligned with the end block and the platen by means of four $3/16$ -in. diameter pintles, the ends of which projected into holes in the end block and in the platen. See Figs. 7 and 8. The top and bottom platens were clamped to the machine crosshead and the pedestal, respectively.

2.3 LATERAL LOADING SYSTEM

2.3.1 Parts and Functions

As mentioned earlier, lateral loading was applied by means of a compressed air system. Actually, this could have been achieved through a hydraulic pressure system (oil or water) or through hydraulic jacks with rubber cushions. The former system, however, would require that in order to avoid variation in the pressure head, the specimen be placed horizontally with the resulting inconvenience in applying axial load, while the latter system could produce only "approximately uniform" loading. With the compressed air loading system, both of these disadvantages were avoided.

The lateral loading system consisted of the following two principal parts (see Fig. 4):

- The source of compressed air and the pressure controls - a compressed air bottle, an accumulator with valves, and a mercury manometer. See Fig. 5 on the left.
- The loading application system - a pressure box with an inner cell in it. A general view of it is given in Fig. 6.

2.3.2 Pressure Controls

From the compressed air bottle the air goes through an automatic control gage (set roughly at 15 to 20 psi) into

the accumulator. The automatic control gage can be seen on top of the compressed air bottle in Fig. 5. Then, from the accumulator via a control valve the air enters the inner cell which is on a mercury manometer and is manually regulated by means of the control and relief valves.

The accumulator is a steel box approximately 2.5 ft. x 2 ft. x 1 ft. made of 1/16-in. plate. It serves as a reservoir of air with a constant pressure intensity considerably lower than that in the air bottle (20 versus 2000 psi). Fine adjustment of the air pressure is made easier this way.

2.3.3 Pressure Box

The construction of the pressure box is illustrated by the exploded view in Fig. 7 (also Figs. 4 and 6). Two 12-in. channels and two 9-in. channels are connected to form a rectangular frame which constitutes the four sides of the pressure box. A back wall built of wooden boards and 7-in. tee stiffeners is bolted to this frame as shown in Fig. 6. The design of the pressure box was controlled by the stresses as well as by the deflection of the side panels (less than 1/32 in. under lateral pressure). The pressure box stands on four adjustable vertical supports. See Figs. 4 and 9. The vertical supports were made by welding four 1-in. diameter 1-1/4-in. long threaded studs to the bottom ends of the side channels (panels). Hexagonal nuts, screwed on each of the studs part-way, served to adjust the height of the supports.

To eliminate shifting of the pressure box when a nut was turned for height adjustment, a thin brass plate anchored in the studs had been placed between the nuts and the pedestal surface.

Four articulated links, one at each corner, (see Figs. 4, 6, and 7) were used for the connection between the pressure box and the specimen. Their purpose was to transmit all horizontal forces due to lateral loading from the specimen to the pressure box, thus establishing a system of equilibrium in the horizontal direction, and to allow free rotation and free vertical movement of the ends of the test specimen. The links and the link pins were fabricated of high strength steel.

The inner cell used in the application of lateral loading was a weather balloon made of a very resilient plastic. To avoid excessive stretching and bursting of the balloon material during inflating, a frame made of 3/4-in. wooden dowels and slightly smaller than the inside dimensions of the pressure box was assembled inside the balloon. Rubber strips, about 2-in. wide, were used to cover all the clearance gaps to prevent the balloon from squeezing out and bursting. They were attached by means of two-faced adhesive tape. A simpler, but much more expensive, scheme would have been to fabricate the inner cell of thick rubber (1/16-in. thick) or of rubber impregnated canvas.

2.4 BRACING

Horizontal bracing was made of two 4-in. channels. It was provided to safeguard against excessive deflection of the specimen during testing and also to support the side panels of the pressure box. The horizontal bracing channels together with four short channels welded on the side panels and two tee stiffeners on the back wall formed two closed rings which gave rigidity and strength to the whole pressure box assembly (Figs. 4 and 6).

To provide a temporary lateral support to the specimen during assembling and application of lateral loading, two 2-1/2-in. angles were connected to the top end block of the specimen and to the machine pedestal. In Fig. 6 one of these angles can be seen spanning diagonally between the top of the specimen and the edge of the pedestal. In order that there would be no danger of the top of the specimen shifting and thus upsetting vertical alignment, the angles were loosened only after an axial force of 20 to 50 kips had been applied.

2.5 INSTRUMENTATION

Instrumentation consisted of dial and strain gages, and it was extensive enough to give a reasonably complete picture of the behavior of the specimens and testing apparatus.

2.5.1 Dial Gages

Dial gages were AMES dial gages with one thousandth inch divisions and a stroke of one inch. They were used for the following measurements:

a) Lateral deflection of the specimen. Measurements were taken at a number of points so as to cover, more or less, the whole area of the specimen. All gages of this group were mounted on the dial gage frame which was attached to the machine pedestal. See Figs. 5 and 6. A total of 27 gages were needed for these measurements.

b) Rotation of the specimen at ends. The arrangement for this purpose is obvious from the sketch in Fig. 8. The angle of rotation is obtained by dividing the dial gage reading by the distance from the gage to the center of rotation (9-in.). Four gages, two at each specimen end, were used to measure rotation.

c) Change in the distance between the ends of the specimen. Actually, the change in the distance between the machine cross head and the pedestal was measured, but this introduced a rather small inaccuracy since the deformation of the end fixtures compared with that of the specimen was of a negligible magnitude. Two gages, one on each side of the specimen, were used for this purpose.

The distance between a dial gage and a corresponding point to be measured was bridged with a thin black wire. For the measurement of lateral deflections the wire was attached to small screws on the face of the specimen.

2.5.2 Strain Gages

All strain gages were electric-resistance SR-4 type A-1 linear gages.

On the average 60 strain gages were used per test specimen. In addition, two gages were cemented on each of four articulate links to check the proper transmission of lateral forces and a possible development of friction between a link and a pin.

The strain readings were made on two conventional strain indicators with switch boxes and on an automatic strain reader (Strain Gage Digitizer Model 329 by Franklin Electronic Company); see the right side of Fig. 5. The Digitizer serving fifty gages and operated by two men automatically balanced each gage and typed the strain readings on a paper tape.

2.6 ALIGNMENT

The apparatus permitted an alignment for the axial force only in the direction parallel to the plate surface of the specimen. For this purpose the testing machine crosshead was tilted by turning cylindrical wedges till the strain readings

for a pair of strain gages on the plate and stiffener at the left side of the specimen essentially equalled those at the right side. Applied in increments of 25 kips, the maximum load used for this purpose was 100 kips.

Only a geometrical alignment was possible in the direction perpendicular to the plate surface (weak direction). This was accomplished at the time of the attachment of the test specimens to the end blocks.

In most cases the alignment in both directions was surprisingly good.

3. D I S C U S S I O N

The performance of the apparatus was found very satisfactory. Loads in both directions, axial and lateral, could be accurately and easily controlled. Loading-unloading tests especially conducted in the elastic range to check how well the pin-ended conditions were simulated showed that deviations, if any, were within the range of the accuracy of the strain and dial gage readings. The strain gages on the links showed practically no friction developing between the pins and the links.

Unexplainable outward movement of the top end block was observed during the application of lateral pressure (about 0.03-in.). This, however, had no influence on the test results.

In the future some modifications of the apparatus are anticipated to make it more readily adaptable for specimens of different overall dimensions. The length, for one, can be adjusted by a splice in the side panels. Then, a specimen of the same series can be used as a back wall, while another identical specimen is being tested.

If the specimens are to be tested only axially, without lateral loading, the end fixtures can be used, and have been, for specimens of other dimensions.

It is hoped that this paper will be helpful to investigators who are contemplating testing stiffened panels or similar structural elements by subjecting them to axial and uniform lateral loads.

4. A C K N O W L E D G E M E N T S

The apparatus was designed in conjunction with an experimental study on longitudinally stiffened plate panels which is a part of a research program on built-up members in plastic design currently conducted at Fritz Engineering Laboratory, Lehigh University, Bethlehem, Pennsylvania, of which Professor William J. Eney is Head and Dr. Lynn S. Beedle is Director.

The research is sponsored by the Department of the Navy under the Office of Naval Research Contract No. Nonr 610(03).

The contributions to the success of the study, which has enabled the author to write this paper, are gratefully acknowledged to the following individuals and organizations:

Mr. John Vasta of the Bureau of Ships who initiated this study and gave his continuous encouragement and support;

Dr. Lynn S. Beedle, director of the project;

Mr. Ti-ta Lee, whose dedicated and imaginative assistance was invaluable;

Dr. Bruno Thurlimann, who made many helpful suggestions;

Bethlehem Foundry, where the larger parts of the apparatus were fabricated;

Mr. K. R. Harpel with his crew of technicians, who fabricated all the other parts in Fritz Laboratory and assembled the apparatus;

Mr. I. J. Taylor and his Instruments Group, who were responsible for the instrumentation;

Mr. S. A. Gewlik and Mrs. L. M. Morrow who, respectively, prepared the drawings and typed the manuscript.

5. BIBLIOGRAPHY

1. Ostapenko, A., and Ti-ta Lee: "Tests on Longitudinally Stiffened Plate Panels Subjected to Lateral and Axial Loading", Fritz Engineering Laboratory Report No. 248.4, August 1960.
2. McPherson, A. E., S. Levy, and G. Zibritosky: "Effect of Normal Pressure on Strength of Axially Loaded Sheet-Stringer Panels", NACA, Technical Note No. 1041, July 1946.

6. LIST OF CAPTIONS

- Fig. 1 LONGITUDINALLY STIFFENED PLATE PANELS IN SHIP
STRUCTURES - Loading: Axial Load P Due to Hogging
and Hydrostatic Pressure q
- Fig. 2 TEST SPECIMEN - LONGITUDINALLY STIFFENED PLATE PANEL
- Fig. 3 APPARATUS - LOADING SYSTEM (Schematic)
- Fig. 4 CONSTRUCTION OF APPARATUS - GENERAL ARRANGEMENT
- Fig. 5 TEST SETUP AND INSTRUMENTATION - FRONT VIEW
- Fig. 6 TEST ASSEMBLY - SIDE VIEW
- Fig. 7 EXPLODED VIEW OF END FIXTURES AND PRESSURE BOX
- Fig. 8 END FIXTURE AND END ROTATION GAGE ARRANGEMENT
- Fig. 9 END FIXTURE AND END ROTATION GAGE ARRANGEMENT
- Fig. 10 ADJUSTABLE VERTICAL SUPPORTS FOR PRESSURE BOX

7. FIGURES

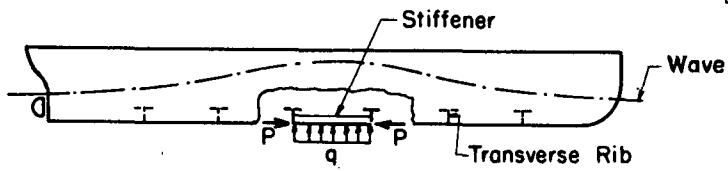
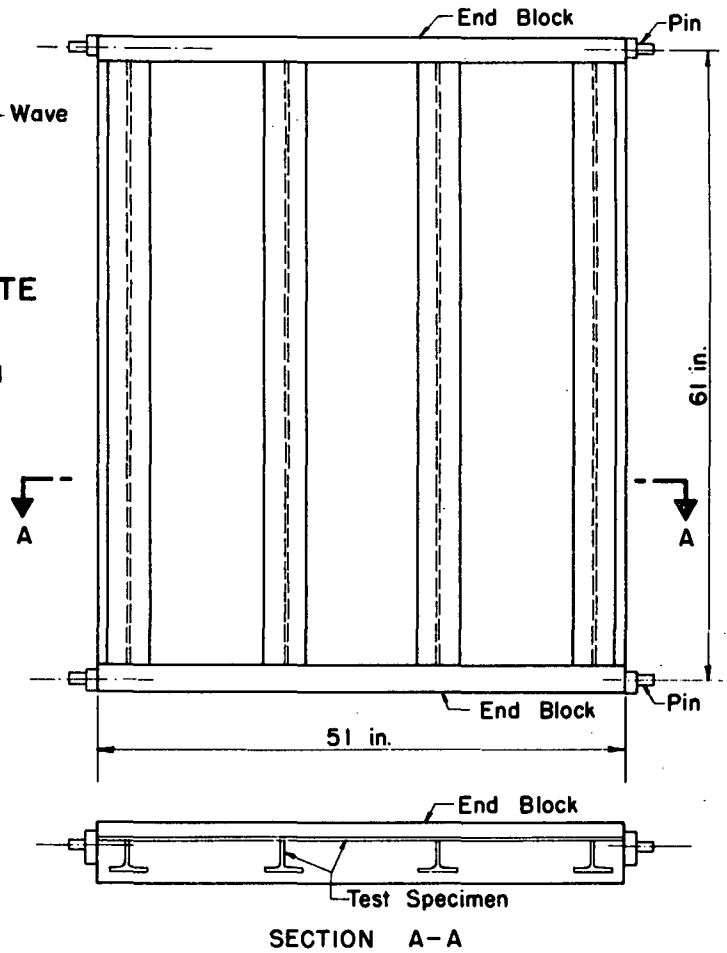

Fig. 1 LONGITUDINALLY STIFFENED PLATE PANELS IN SHIP STRUCTURES

Loading: Axial Load P Due to Hogging and Hydrostatic Pressure q



SECTION A-A

Fig. 2 TEST SPECIMEN - LONGITUDINALLY STIFFENED PLATE PANEL

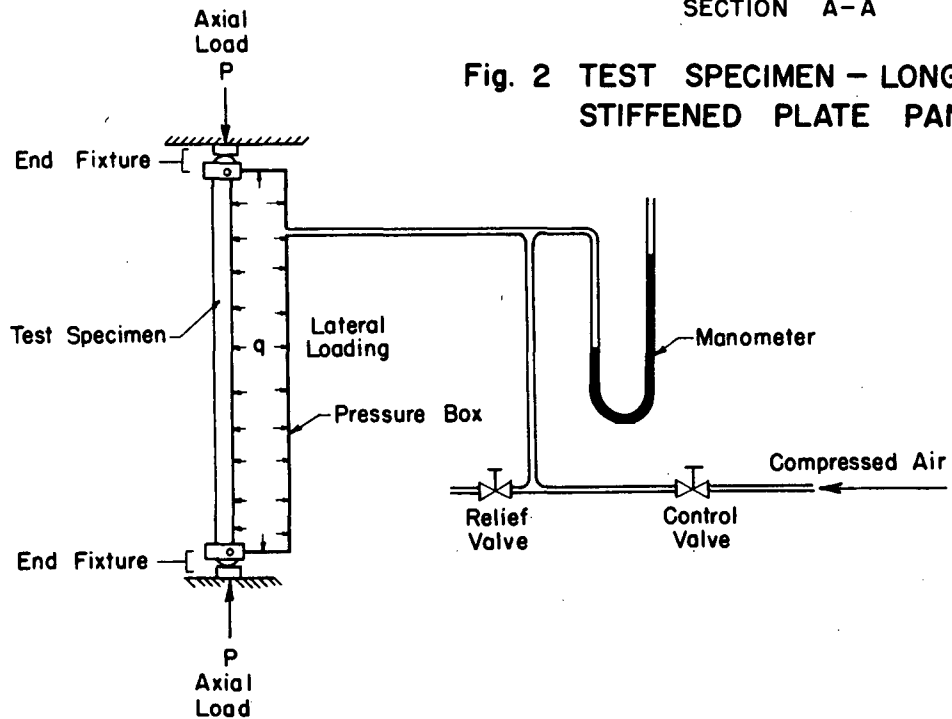
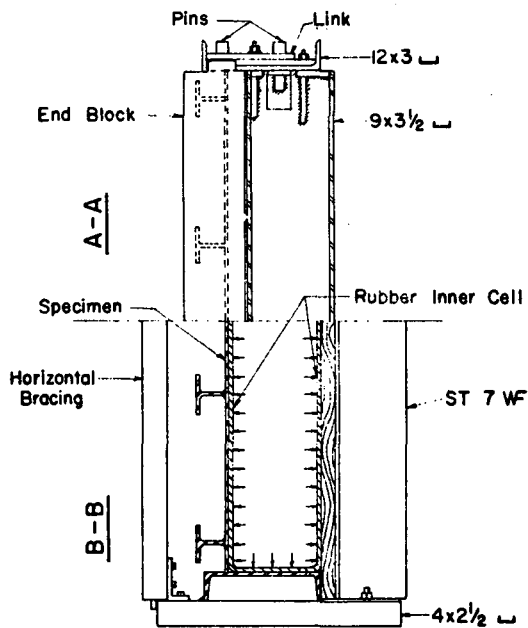
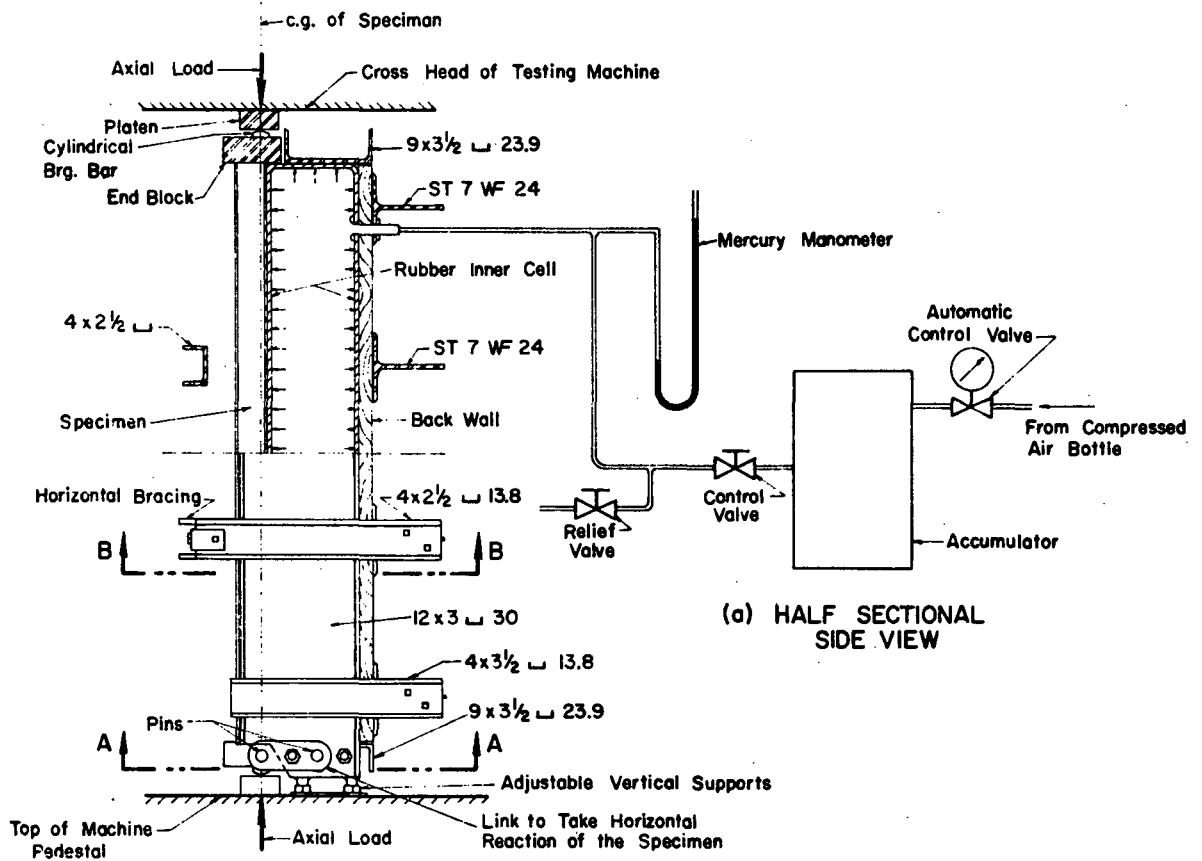

Fig. 3 APPARATUS - LOADING SYSTEM (Schematic)



(b) SECTIONS A-A & B-B

Fig. 4 CONSTRUCTION OF APPARATUS — GENERAL ARRANGEMENT

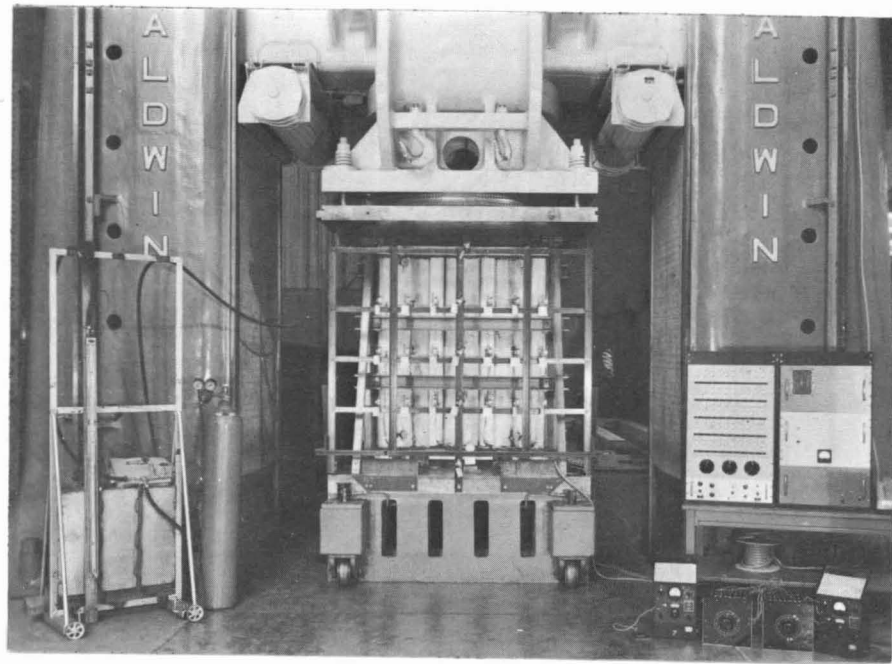

FIG. 5 TEST SETUP AND INSTRUMENTATION
FRONT VIEW

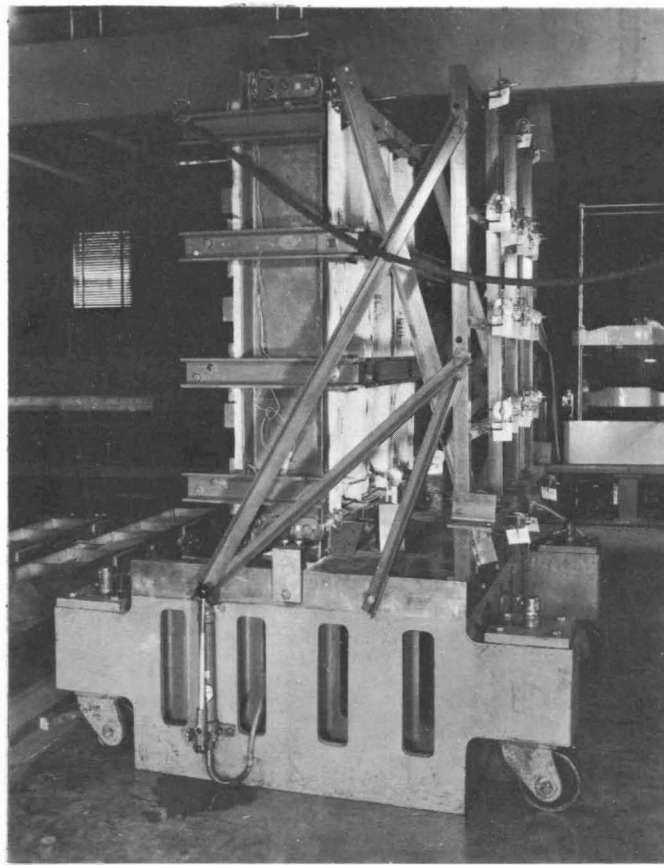
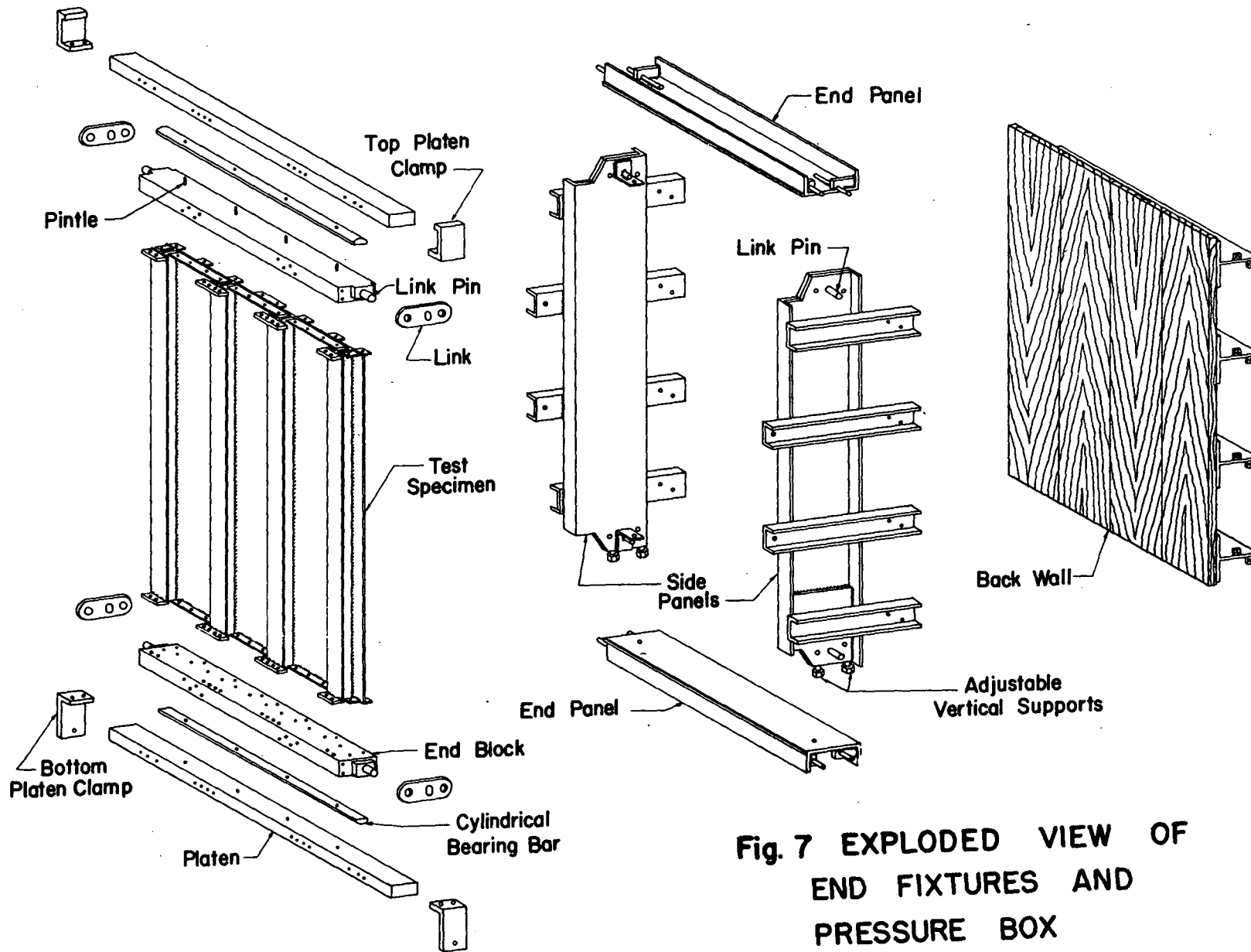

FIG. 6 TEST ASSEMBLY
SIDE VIEW



**Fig. 7 EXPLODED VIEW OF
 END FIXTURES AND
 PRESSURE BOX**

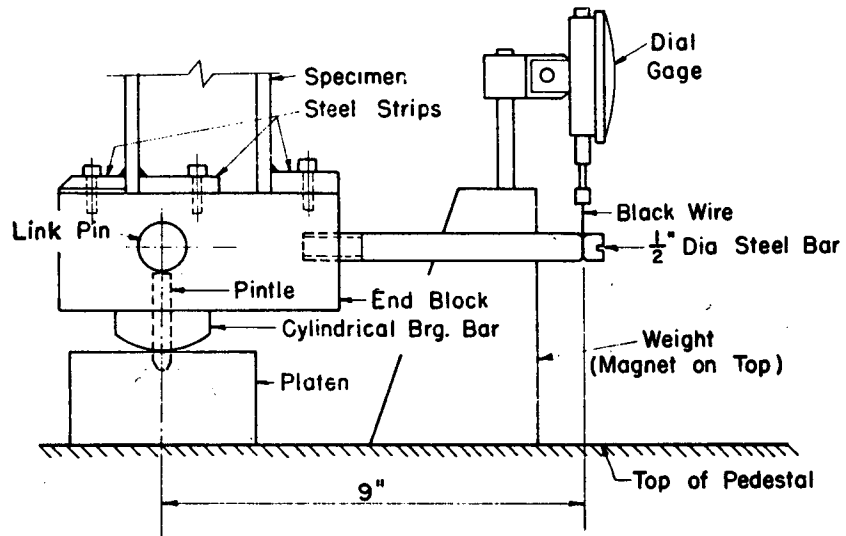

Fig. 8 END FIXTURE AND END ROTATION GAGE ARRANGEMENT

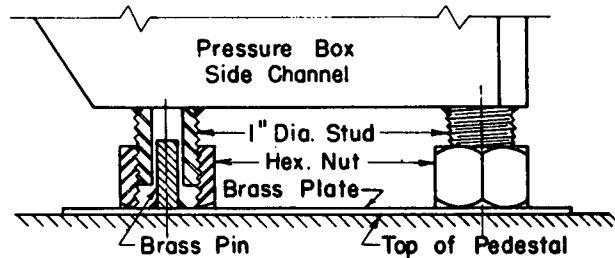

Fig. 9 ADJUSTABLE VERTICAL SUPPORTS FOR PRESSURE BOX