

Lehigh University Lehigh Preserve

Fritz Laboratory Reports

Civil and Environmental Engineering

1957

Summary on prestressed concrete program at Lehigh University, Proc. World Conference on Prestressed Concrete, July 1957, p. A30-1, Reprint No. 175 (57-18)

C. E. Ekberg Jr.

Follow this and additional works at: <http://preserve.lehigh.edu/engr-civil-environmental-fritz-lab-reports>

Recommended Citation

Ekberg, C. E. Jr., "Summary on prestressed concrete program at Lehigh University, Proc. World Conference on Prestressed Concrete, July 1957, p. A30-1, Reprint No. 175 (57-18)" (1957). *Fritz Laboratory Reports*. Paper 1549.
<http://preserve.lehigh.edu/engr-civil-environmental-fritz-lab-reports/1549>

This Technical Report is brought to you for free and open access by the Civil and Environmental Engineering at Lehigh Preserve. It has been accepted for inclusion in Fritz Laboratory Reports by an authorized administrator of Lehigh Preserve. For more information, please contact preserve@lehigh.edu.

Project 223

Report to
Lehigh Prestressed Concrete Committee

on

LEHIGH UNIVERSITY INVESTIGATION OF
PRESTRESSED CONCRETE BRIDGE MEMBERS

August 1961 to July 1962

Submitted by:

C. L. Hulsbos

Research Professor of Civil Engineering
Chairman, Structural Concrete Division

Fritz Engineering Laboratory
Lehigh University
Bethlehem, Pennsylvania

July, 1962

INTRODUCTION

The project is currently operating under a contract which was approved for a nineteen month period -- December 1, 1961 to June 30, 1963. The work is a continuation of the previous contract and includes two distinct phases: 1. Ultimate strength of prestressed concrete beams under the combined action of bending and shear and 2. Fatigue failure of prestressed concrete beams.

The work has continued with Dr. C. L. Hulsbos as project director and with J. M. Hanson, Research Instructor, as principal investigator for the shear phase of the project. F. S. Ople, Jr., Research Associate has replaced R. F. Warner as the principal investigator for the fatigue phase. Dr. Warner resigned from Lehigh University in October after he had completed his part of the project. Other research personnel include D. Kocaoglu, D. M. Miller, and W. F. Chen, all Research Assistants.

ULTIMATE STRENGTH OF PRESTRESSED CONCRETE BEAMS
UNDER THE COMBINED ACTION OF BENDING AND SHEAR.

In reviewing the work done since the last meeting of the LPCC on August 10, 1961, three major items need to be listed and discussed. The first of these is the completion of testing in the E series and the associated work on study of the test data. The second item pertains to the work done in preparation of Progress Report No. 22, which was distributed in April. Item three is the work connected with the planning, preparation, and initiating of testing in the F series.

With reference to the first item, it may be recalled that as of August 10, 1961 thirteen of the eighteen planned tests in the E series had been completed. The preliminary results of these thirteen tests were presented to the committee at the last LPCC meeting. Following that meeting the remaining five tests were carried out. Two of these, E.10 and E.11, were fatigue tests, and the remaining three, E.16, E.17, and E.18, were static tests.

Tables 1 through 7 give the principal results of the complete E series of tests. Figures 1 through 10 present selected parts of data pertaining to these tests, emphasizing in particular the two fatigue tests, E.10 and E.11. These

tables and figures are largely self-explanatory, and will be discussed, along with additional information, at the LPCC meeting.

Tentative conclusions drawn from the E series of tests are as follows:

1. For the type and strength of beam tested, on an a/d ratio of 3.39, the T.R.P.C. equation in the ACI-ASCE Joint Committee 323 Report,

$$A_v = \frac{1}{2} \left(\frac{V_u - V_c}{f_y j d} \right) s$$

was conservative by a factor of greater than 2.

2. Using either $4\sqrt{f'_c}$ as the limiting principal tensile stress at the C.G.C. of the section to calculate the value of the diagonal tension cracking load, or displacing the flexure cracking curve a distance d in the direction of increasing moment to determine the flexure shear cracking load, provides a basis for calculating the inclined cracking load which was conservative for all beams in the E series. The ratio of V_c calculated in this manner to V_c observed was non-uniform, particularly with regard to shear spans of a/d less than approximately 4.

3. For a pretensioned beam subjected to one overload of sufficient magnitude to develop diagonal tension inclined cracks, there is a range of subsequent dynamic loadings which will be more critical in fatigue of the web reinforcement than in fatigue of the longitudinal prestressing strand. With regard to the two beams tested, an apparent criterion for determining if the member would be critical in fatigue is the linearity of the load deflection curve. That is, if the repeated loadings are in a range such that the load deflection curve for the member in this range is approximately linear, a fatigue failure would not be expected.

4. Prestressed beams overloaded to the extent that yielding of the prestressing strand takes place may have a sharply reduced ultimate shear strength upon being re-loaded.

The formal report to the LPCC on the E series of tests will be entitled "Overload Behavior of Prestressed Concrete Beams with Web Reinforcement". It is expected that this report will be distributed to committee members this fall.

The second item pertains to preparation and distribution of Progress Report No. 22, entitled "Further Investigation

into the Shear Strength of Prestressed Concrete Beams without Web Reinforcement". This report was distributed to committee members last April after having been substantially revised from its preliminary form.

With regard to the third item, the planned tests and test beam details for the F series are shown in Figure 11. The purpose of this series is to determine the effect on ultimate shear strength of variation in the amount of web reinforcement. Shear spans to be investigated will vary from an a/d ratio of 2.12 to 7.05. Anticipated concrete strength at the time of test of F series specimens will be approximately 7000 psi.

The particular problem in planning the specimens in the F series has been the selection of suitable web reinforcement. Two criteria had to be considered. First, the amount of web reinforcement had to be very small. Second, the material to be used as web reinforcement must have characteristics similar to the hot rolled deformed bars commonly used as stirrups; that is, the material must have a well defined yield point, adequate ductility, and provision for bond.

To satisfy the first consideration required the use of web reinforcement which varied in size from a maximum of #2 bars to a minimum in the neighborhood of 10 gage wire. Preliminary tests on cold-drawn steel wire for concrete reinforcement, in accordance with ASTM specification A 82-34, indicated that this material had neither the well defined yield point or the ductility required in the second consideration. Further tests indicated that suitable choices for web reinforcement would be 7/32 in. round hot rolled rod, and 8 and 10 gage annealed wire. Since these materials were smooth, bond would have to be provided by using hooks on the ends of the stirrups. At a meeting with the Pennsylvania Department of Highways it was suggested that the type of knurled reinforcing used in masonry reinforcement be considered in place of the 7/32 in. round and 8 and 10 gage material. Masonry reinforcement is fabricated from basic ASTM A 82-34 wire, with deformations introduced by the knurling operation. Tests on this material indicated that by annealing and pickling the desired characteristics of a well defined yield point and adequate ductility could be achieved. In

addition, the deformations in the material would eliminate the need for hooks at the end. This is the material, in 9 gage and 3/16 in. sizes, which has been selected in addition to the #2 bars, and its use is indicated in the outline of tests in Figure 11.

As of this writing four beams in this series have been cast: F-X1, F-2, F-4 and F-7. It is expected that F-X1 will have been tested before the LPCC meeting, and the results will be discussed at that time.

FATIGUE FAILURE OF PRESTRESSED CONCRETE BEAMS

INTRODUCTION

Progress Report No. 24 presents a study on the probable fatigue life of prestressed flexural members under cyclic loading of either constant or varied magnitude. The method for determining the fatigue life is based on the fatigue strength of the steel reinforcement only. The proposed solution is therefore limited to under-reinforced prestressed concrete beams.

The report briefly describes a lower bound estimate of the fatigue life of over-reinforced concrete beams. Conditions are considered in the extreme concrete compression fiber only, and the problem is treated as a case of fatigue failure of a concrete element under repeated axial loading.

Many fatigue tests have been done on plain concrete cylinders under compressive axial loads. Applying information from cylinder tests to predict fatigue life of beams may be misleading because concrete fatigue failure occurs in the compression region of the beam in the presence of a stress gradient.

The main objective of this phase of the research program is to obtain a method for determining the fatigue life of over-reinforced prestressed concrete flexural members. The study will take into particular consideration the presence of a compressive stress gradient in the concrete.

Fatigue tests on plain concrete specimens of rectangular cross-section will be used to establish S-N-P relationships for axial and eccentric load cases. The repeated eccentric load will be applied to the specimen so as to produce a stress distribution simulating that which can be found in a flexural member. The effect of infrequent over-loads mixed with a predominant load will likewise be studied by conducting cumulative damage fatigue tests.

In addition to the specimen tests, a series of beams will be tested in fatigue. These beams will be designed to fail by fatigue of the concrete. Fatigue data from the concrete specimen tests will be used to predict the fatigue life of the test beams.

CONCRETE SPECIMEN TESTS

Specimens

Plain concrete specimens are manufactured in batches of 20 - 4" x 6" x 12" blocks and 12 - 6" ϕ x 12" cylinders. The concrete blocks are cast in 6" x 6" x 36" steel forms ordinarily used for modulus of rupture specimens. A two-inch plywood false bottom is used to reduce one dimension to 4". Steel plates divide the form into three 12" lengths.

One batch of specimens requires 6.5 cu. ft. of concrete and this amount is mixed at one time in a horizontal drum, positive action mixer. Except for the first few batches, the concrete mix has been held fairly constant with slight variation in the water content. The specimens are cured in a moist room until 28 days of age after which they are stored at room temperature. Specimen age at test varies from 45 to 60 days.

The batches are designated as AA, BB, CC, etc. according to the sequence of preparation. The batches are manufactured at a rate of approximately one batch per ten days. Table 8 lists some of the pertinent information on the different batches of concrete specimens.

Test Set-Up

A set-up for fatigue testing of concrete specimens has been designed. End fixtures that allow the application of either axial or eccentric repeated loads on the concrete block specimen have been fabricated. The load applying unit consists of an Amsler pulsator and a 110 kip hydraulic jack. The performance of the test set-up has been evaluated by means of pilot tests and found satisfactory.

Test Program for 1962-1963

The proposed fatigue test program is shown in Figure 12. The experimental program for plain concrete specimens is divided into three main groups: static tests, constant cycle fatigue tests, and cumulative damage fatigue tests.

From each batch of specimens (20 blocks and 12 cylinders) a definite number of specimens will be allotted to the different test groups. (See Table 8.) The method of assigning the specimens to the test groups will be done in a random manner.

The main test groups are further divided into subgroups which are enumerated and briefly explained in the following:

Group 1 - Static Tests: Stress-strain relationships and ultimate strength of the concrete will be obtained from the static tests. From each batch of specimens, six

blocks and twelve cylinders will be assigned to this test group.

Group 1a - Static Tests of Blocks with Axial Loads (e = 0):

Three blocks will be tested with static axial loads to failure. The ultimate strength determined from these tests will be used as control for fatigue tests of blocks with repeated axial loads (Groups 2a and 3).

Group 1b - Static Tests of Blocks with Eccentric Loads (e = 1"):

Static eccentric load vs. strain tests will be conducted on three blocks to obtain stress-strain relationships. The information will be used to determine the loads for fatigue tests of blocks having the same eccentricity (Group 2b).

Group 1c - Static Tests of Cylinders: All twelve cylinders from one batch will be tested statically to failure. Three cylinders at a time will be tested at four different instances - at 28 days after casting the specimens, at the start, at halfway, and at completion of the fatigue test period for the same batch.

Group 2 - Constant Cycle Fatigue Tests: A constant minimum stress level of ten percent of the static ultimate strength

will be used in these fatigue tests. About ten concrete blocks will be assigned to this test group. These specimens will in turn be divided into two groups according to the following:

Group 2a - Constant Cycle Fatigue Tests with Axial Loads ($e = 0$):

The purpose of these tests is to establish the basic S-N curve for axially loaded specimens. The maximum stress levels will vary from 65 to 80 percent of the static ultimate. Five or six specimens per batch will be tested at different stress levels; thus, at a particular maximum stress level, the test points will be from different batches. It is planned to test at least eight specimens per maximum stress level.

Group 2b - Constant Cycle Fatigue Tests with Eccentric Loads ($e = 1$ "): The aim of these tests is to establish the S-N curve for eccentrically loaded specimens. Load applied at this particular eccentricity will produce a stress gradient increasing from zero to a maximum stress along the six-inch dimension of the block, the load being applied in the direction of the 12-inch dimension. The extreme fiber stress will be used to control the load. The maximum stress levels will vary from

80 to 95 percent. Four or five specimens per batch will be assigned to this test group, the distribution of specimens among the different stress levels being similar to that of Group 2a.

Tentative plans include a few constant cycle fatigue tests to be conducted with eccentric loads applied at $e = 1/2"$. These tests however, will only be carried out if time and availability of specimens allow.

Group 3 - Cumulative Damage Fatigue Tests: The effect of superposing a few overloads over a predominant load will be studied by conducting cumulative damage tests on concrete block specimens. For the present, it is planned to investigate axially loaded specimens only. Decision to extend the investigation to include eccentrically loaded specimens will be deferred to a later date. The minimum stress level will be maintained at ten percent of the static ultimate strength. Four or five specimens per batch will be assigned to this test group.

Group 3a - Cumulative Damage Tests with One Overload Level:

Approximately fifteen specimens will be tested in fatigue

with one overload level mixed with a predominant load.

Details of the proposed tests are listed in Table 9.

Group 3b - Cumulative Damage Tests with Two Overload Levels:

Approximately fifteen specimens will also be tested in fatigue with two overload levels mixed with a predominant load. Details of the proposed tests are listed in Table 10.

It is planned to test one batch of specimens within fifteen days. The fatigue tests of Groups 2 and 3 will be conducted at random with respect to test sequence.

PROPOSED BEAM FATIGUE TESTS

The test program for 1962-1963 will include a series of beam fatigue tests. The main purpose of these tests is to investigate the accuracy of applying fatigue data from the concrete specimen tests to the prediction of the fatigue life of a flexural member designed to fail by concrete fatigue.

The beam tests will be conducted after the concrete specimen tests have been completed. Six or eight beams will be tested. At least one beam will be used as a comparison static test. Tentatively, constant load cycle tests will be conducted on the beams. If, however, cumulative damage tests

with eccentric loads have been performed on the concrete specimens, then a few of the beams may be tested with varied load cycle.

CURRENT STATUS OF PROGRAM

As of July 1962, the following aspects of the experimental program have been completed:

Pilot Tests

Static and fatigue tests on plain concrete blocks were conducted as part of the pilot tests which were completed in April 1962. The primary aims of the pilot tests were to determine: 1) the performance of the test set-up for eccentric loading, and 2) the size of the plain concrete specimens to be adopted for the fatigue test program.

Pilot test results have indicated satisfactory performance of the test set-up. A specimen size of 4" x 6" x 12" has also been decided upon.

Manufacture of Specimens

Eight batches of specimens have so far been manufactured. Two or three more batches are planned to be prepared. (See Table 8).

Concrete Specimen Tests

Four batches of specimens have been tested. Specimens from batches AA and BB were utilized mostly for pilot tests. Table 11 is a summary of the results of the concrete specimen tests which have been completed to date. Constant cycle fatigue test (Test Group 2) results are plotted in Figure 13.

REPORTS AND PUBLICATIONS

A paper "Lateral Distribution of Load in Multibeam Bridges -- A Summary of Research at Lehigh University" by C. L. Hulsbos was presented at the Annual Meeting of the Highway Research Board, January, 1962. The paper will be published by the Board.

Progress Report No. 22 "Further Investigation into the Shear Strength of Prestressed Concrete Beams without Web Reinforcement" by Francis M. McClarnon, Minoru Wakabayashi, and Carl E. Ekberg, Jr. has been completed and distributed.

Progress Report No. 24 "Probable Fatigue Life of Prestressed Concrete Flexural Members" by R. F. Warner and C. L. Hulsbos is completed and ready for distribution.

A paper "Probable Fatigue Life of Under-Reinforced Prestressed Concrete Beams" was prepared by R. F. Warner and C. L. Hulsbos for presentation at the Fourth Congress of the International Federation for Prestressing. However, the paper was received too late to be included in the program.

A series of papers based on the material in Progress Report No. 24 is under preparation and when completed will be submitted to ACI for publication.

A progress report on last year's work on the shear phase of the project is under preparation.

Table 1. Outline of Tests

Shear Span a	Size and Spacing of Web Reinforcement	Web Reinforcement Percentage, r	Test Beam
3' 0"	#2D at $8\frac{3}{4}$ "	0.37	E.14
	#2D at $8\frac{3}{4}$ "	0.37	E.15
4' 0"	None	0	E.4
	#3D at 6"	1.22	E.5
	#3D at 8"	0.92	E.6
	#3D at 10"	0.73	E.7
	#3S at 6"	0.61	E.8
	#3S at 8"	0.46	E.9
	#3S at 6"	0.61	E.10F
	#3S at 8"	0.46	E.11F
	#3S at 10"	0.37	E.12
	#2D at $8\frac{3}{4}$ "	0.37	E.13
	#2S at 6"	0.28	E.16
	#2S at 8"	0.21	E.17
#2S at 10"	0.17	E.18	
5' 0"	None	0	E.3
6' 0"	None	0	E.2
7' 6"	None	0	E.1

Notes:

1. S and D in the call-out for the web reinforcement indicate single legged and double legged stirrup, respectively.
2. The web reinforcement percentage is based upon the web width.
3. The letter F following E.10 and E.11 indicates fatigue test. All other tests were static tests.

Table 2. Prestress Force at Casting and Release

Test Beams	Total Prestress Force (Kips)		Per Cent Change
	At Casting	At Release	
E.1, E.2 & E.3	113.7	115.6	+1.7
E.4, E.5 & E.6	113.9	119.4	+4.8
E.7, E.8 & E.9	114.9	116.5	+1.4
E.10, E.11 & E.12	113.7	117.3	+3.3
E.13, E.14 & E.15	113.5	113.1	-0.4
E.16, E.17 & E.18	113.3	121.4	+7.1

Table 3. Properties of the Concrete

Beam No.	At Transfer			At Test				
	Age (days)	f'_c (psi)	E_c^1 (ksi)	Age (days)	f'_c (psi)	f'_r (psi)	E_c^1 (ksi)	E_c^2 (ksi)
E.1	7	5600	3100	67	7030	690	4000	4600
E.2	7	5640	3100	62	6690	740	3600	4200
E.3	7	5690	3100	56	6720	660	3500	4300
E.4	7	5500	3200	55	6960	700	3900	4700
E.5	7	5530	3100	60	6610	670	3800	4600
E.6	7	5440	3200	62	7100	730	4100	4500
E.7	7	5900	3800	62	7230	800	4100	4700
E.8	7	5680	3400	70	6970	650	4400	4700
E.9	7	5630	3500	74	7140	720	4200	4700
E.10	7	6160	3600	228	7360	950	4400	5100
E.11	7	6410	3600	245	7790	960	4200	5000
E.12	7	5590	3300	68	7020	680	3900	4700
E.13	7	6130	3700	27	7320	630	4400	4500
E.14	7	5670	3600	47	6780	680	4100	4700
E.15	7	5730	3500	35	6940	670	4300	4600
E.16	7	5650	3300	64	6950	610	3700	4500
E.17	7	5400	3300	57	6580	600	3800	4300
E.18	7	5520	3200	52	6640	580	3600	4500
Ave.		5720	3400		7000	710	4000	4600

Note: Modulus of elasticity values are designated E_c^1 if determined from cylinder tests and E_c^2 if determined from load-deflection curve of the test beam.

Table 4. Prestress Data

Beam No.	Initial Prestress Force (kips)	Losses			Prestress Force At Test (kips)	Transfer Distance	
		Elastic (%)	Inelastic (%)	Total (%)		End (2) (in.)	End (20) (in.)
E.1	113.7	8.4	12.9	21.3	89.4	11	9
E.2	113.7	8.5	12.7	21.2	89.5	12	14
E.3	113.7	9.0	12.3	21.3	89.4	14	17
E.4	113.9	8.8	11.3	20.1	91.0	11	12
E.5	113.9	8.6	11.9	20.5	90.6	14	14
E.6	113.9	8.5	12.3	20.8	90.2	16	16
E.7	114.9	8.1	11.8	19.9	92.0	13	15
E.8	114.9	8.1	11.8	19.9	92.0	14	15
E.9	114.9	8.1	12.7	20.8	91.0	17	15
E.10	113.7	8.4	15.3	23.7	86.7	15	12
E.11	113.7	8.3	15.4	23.7	86.7	14	16
E.12	113.7	8.5	12.3	20.8	90.0	12	15
E.13	113.5	7.8	7.1	14.9	96.6	15	14
E.14	113.5	7.6	7.3	14.9	96.6	10	11
E.15	113.5	7.3	7.9	15.2	96.3	13	11
E.16	113.3	8.2	11.0	19.2	91.6	13	15
E.17	113.3	8.4	10.2	18.6	92.4	14	13
E.18	113.3	8.5	9.9	18.4	92.6	15	15

Table 5. Static Test Results

Test Beam	$\frac{a}{d}$	$\frac{rf_y}{100}$ (psi)	Shear, V				Nominal Shear Stress At Ult. Load $v_u = \frac{V_u}{b'd}$ (psi)	Mode of Failure
			At Flexure Cracking V_c^f (kips)	At Diagonal Tension Cracking		At Ult. Load V_u (kips)		
				End (2) v_{dt_c} (kips)	End (20) v_{dt_c} (kips)			
E.1	6.35	0	14.4	---	20.4	16.2	381	S
E.2	5.08	0	16	---	23.9	20.8	489	S
E.3	4.23	0	20	26	---	23.1	542	S
E.4	3.39	0	24.4	30	---	30.8	724	S
E.5	3.39	670	24	31.8	28	42.0	988	F
E.6	3.39	505	24	30	28	41.8	984	F
E.7	3.39	401	25	28	28	41.1	965	F
E.8	3.39	335	23.3	28.2	27.2	41.2	968	F
E.9	3.39	253	24	28	28	41.2	968	F
E.12	3.39	203	24	30	30	41.2	968	F
E.13	3.39	220	24	30.6	29.2	41.7	981	F
E.14	2.54	220	33	32.3	33.8	53.8	1263	B
E.15	2.54	220	32	33	34	55.7	1310	F
E.16	3.39	166	24	30	30	39.9	939	F
E.17	3.39	125	24	26	29.4	38.0	894	S
E.18	3.39	101	24	27.1	31.5	38.7	911	S

Notes:

1. Modes of failure indicated by S for shear, F for flexure, and B for bond failure in stirrups.
2. After formation of the diagonal tension cracks in E.1 through E.4, the beams were unloaded, and then re-loaded to collapse. This final load at which collapse occurred is the value of V_u , and it should be noted that this may be less than the value of v_{dt_c} .

Table 6. Fatigue Test Results

Test Beam	Loading Cycle N	V _{min} (kips)	V _{max} (kips)	Remarks
E.10	1	0	32	Initial static test: v _c ^f = 24 kips v _c ^{dt} = 30 kips, both ends
	2 - 6	0	18	Static tests (typical)
	7 - 3,200,000	8	18	Dynamic test at 250 cpm.
	3,200,001 - 4,000,000	8	18	Dynamic test at 500 cpm.
	4,000,001 - 4,526,900	8	28	Dynamic test at 250 cpm. Fatigue failure in one wire of bottom strand at N=4,526,900.
E.11	1	0	32	Initial static test: v _c ^f = 24 kips v _c ^{dt} = 30 kips end (2), 28 kips end (20)
	2 - 5	0	24	Static tests (typical)
	6 - 2,007,500	8	24	Dynamic test at 250 cpm. Fatigue failure in stirrup in shear span at end (2) at N = 2,007,500.

Note: Static tests were run at selected intervals during the dynamic tests. Rest periods, in general for overnight, were permitted after a static test.

Table 7. Re-loaded Static Tests

Test Beam	$P_{ult.}$ (kips)	$M_{ult.}$ (ft-kips)	Ratio of $M_{ult.}$ to Flexural Capacity	Remarks
<p>E.11</p> 	67.8	163	0.98	Existing flexure cracks observed to re-open at $P = 38$ kips. First inclined crack in 6'-0" shear span at $P = 50$ kips. Apparent shear compression failure in 4'-0" shear span.
<p>E.16</p> 	62.5	139	0.84	First inclined crack in 5'-0" shear span at $P = 30$ kips. Apparent shear compression failure in 5'-0" shear span.
<p>E.17</p> 	58.0	139	0.84	Existing flexural cracks observed to re-open at $P = 27$ kips. First inclined crack in 6'0" shear span at $P = 33$ kips. Shear failure in 4'-0" shear span due to stirrup fracture.
<p>E.18</p> 	57.2	138	0.83	Existing flexural cracks observed to re-open at $P = 20$ kips. First inclined crack in 6'-0" shear span at $P = 31$ kips. Apparent shear compression failure in 6'0" shear span.

Table 8. Details of Concrete Specimens for Fatigue Test Program

Batch	Date Prepared	No. of Blocks	No. of Cylinders	f'_c at 28 days (ksi)	Distribution of Concrete Blocks*					
					Group 1		Group 2		Group 3	
					1a	1b	2a	2b	3a	3b
AA	3-29-62	18	13	5.40	Used for pilot tests					
BB	4-11-62	19	14	5.35	Used for pilot tests					
CC	4-25-62	20	13	5.00	6	2	9	3	0	0
DD	5-21-62	20	14	4.84	4	3	7	4	2	0
EE	6- 7-62	20	14	4.62	3	3	5	5	2	2
FF	6-19-62	21	13	4.55	3	3	5	5	2	3
GG	6-29-62	21	12		3	3	5	5	3	2
HH	7-10-62	21	12		3	3	5	5	2	3
II		21	12		3	3	5	5	3	2
JJ		21	12		3	3	5	5	2	3
KK		21	12		3	3	5	5	3	2
			Total		31	26	51	42	19	17

*See Test Program for 1962-63, p. 11, for explanation of test groups.

Table 9. Cumulative Damage Tests with One Overload Level (e = 0)
(Group 3a)

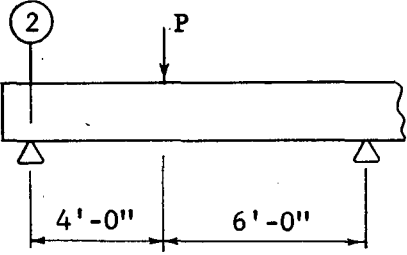
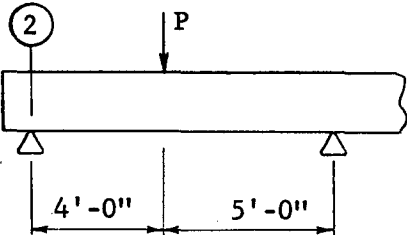
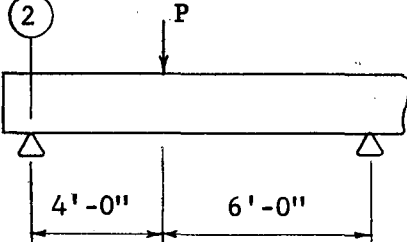
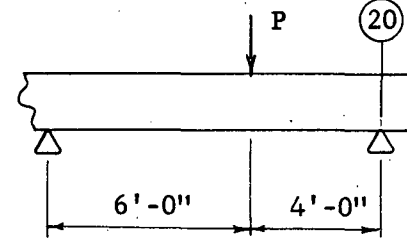
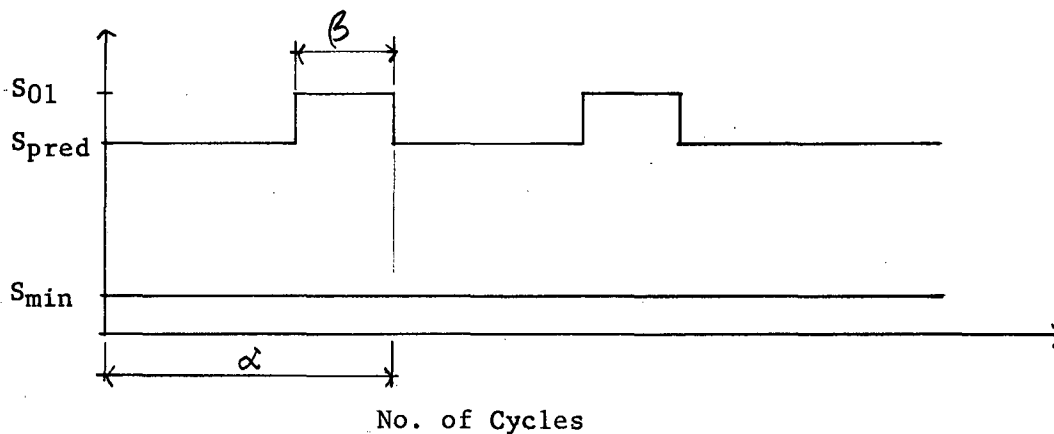

S_{min}	S_{pred}	S_{01}	α	β/α	Replications
10	60	75	15,000	0.40	3
10	65	75	15,000	0.40	3
10	70	75	15,000	0.40	3
10	70	75	15,000	0.25	3
10	65	70	45,000	0.50	3

Table 10. Cumulative Damage Tests with Two Overload Levels (e = 0)
(Group 3b)

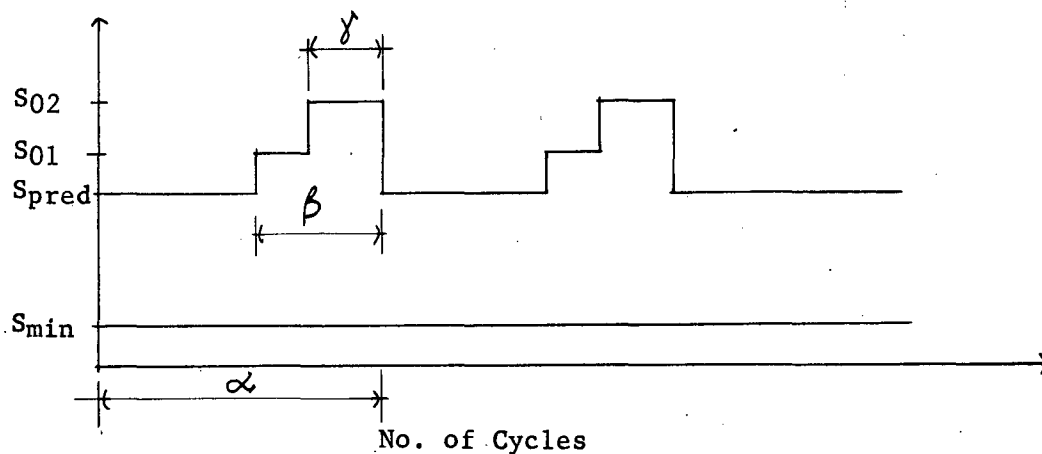

S_{min}	S_{pred}	S_{01}	S_{02}	α	β/α	γ/β	Replications
10	60	70	80	15,000	0.40	0.25	3
10	65	70	80	30,000	0.40	0.40	9
10	70	75	80	30,000	0.25	0.25	3
10	60	75	80	30,000	0.25	0.40	3

Table 11. Concrete Specimen Test Results

A. Test Group 2a - Constant Cycle Tests with Axial Loads ($e = 0$)

Specimen	Date Tested	$S_{max}, \% f'_c$	N
BB-4	5-23-62	65	2,000,000*
BB-11	5-16-62	60	4,050,000*
CC-2	6-12-62	70	2,083,000*
CC-3	6-16-62	75	24,000**
CC-4	6-8 -62	65	2,808,000*
CC-5	6-15-62	80	376,000
CC-6	6-23-62	75	192,000
CC-8	6-16-62	75	136,000
CC-11	6-21-62	80	14,000
CC-15	6-21-62	70	1,048,000
CC-19	6-8 -62	75	17,000**
DD-2	7-11-62	75	5,000**
DD-9	7-9 -62	70	12,000**
DD-14	7-11-62	75	110,000
DD-15	7-12-62	67.5	2,879,000*
DD-17	7-12-62	80	14,000**
DD-20	7-10-62	70	970,000

Table 11. Continued

B. Test Group 2b - Constant Cycle Tests with Eccentric Loads ($e = 1''$)

Specimen	Date Tested	$S_{max}, \% f'_c$	N
BB-14	6-8 -62	95	23,000
BB-18	5-29-62	85	1,520,000*
CC-13	6-17-62	90	28,000
CC-14	6-23-62	95	12,100
CC-20	6-18-62	85	1,700,000*

C. Test Group 3a - Cumulative Damage with One Overload Level ($e = 0$)

Specimen	Date Tested	S_{pred}	S_{01}	α	β/α	N
DD-18	7-12-62	70	75	15,000	0.40	73,500**
DD-19	7-17-62	70	75	15,000	0.40	100,000**

Note: S_{min} for all tests is 10% f'_c

*No failure

**Mode of failure not typical of an axially loaded specimen;
failure resembled eccentrically loaded test.

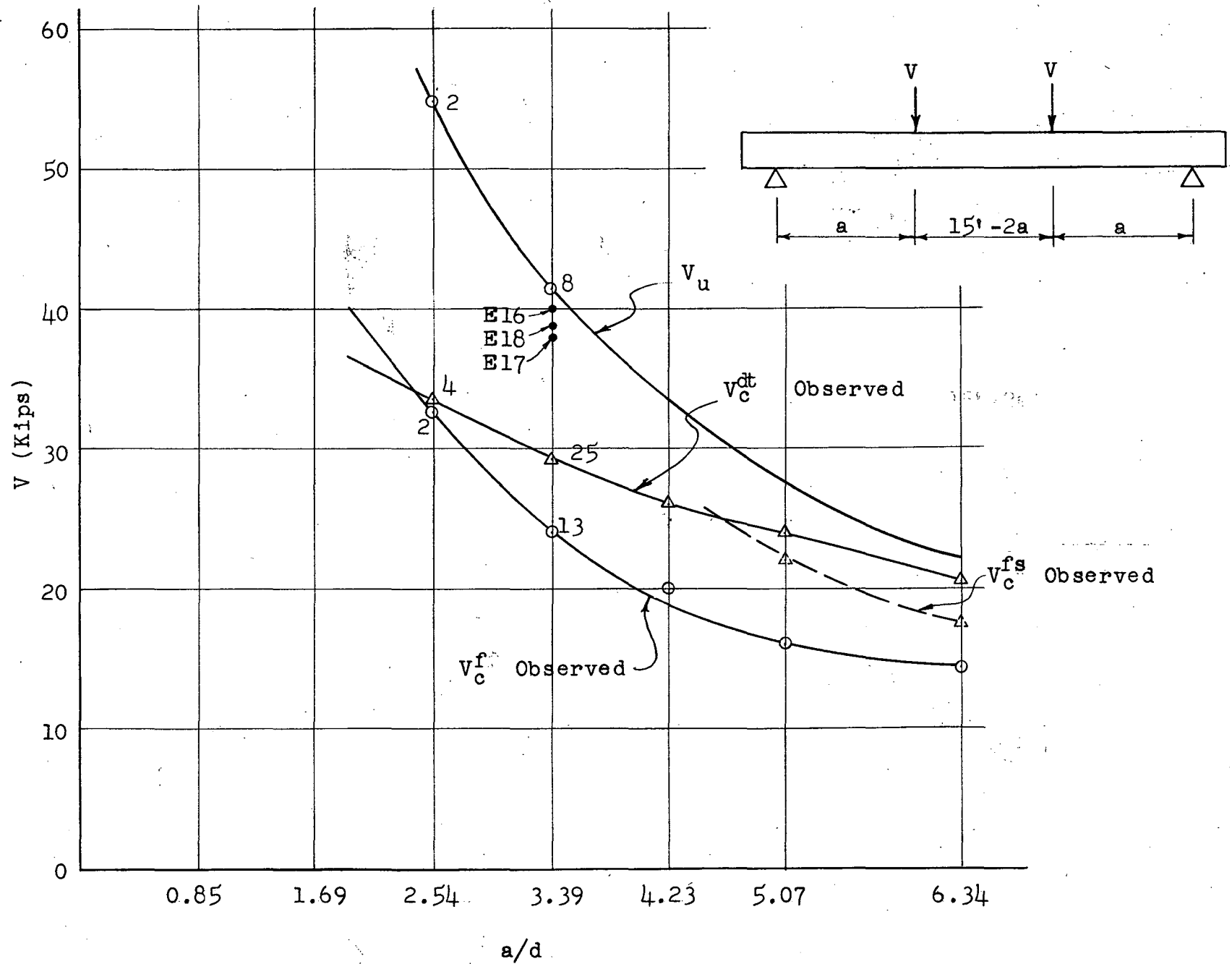

Figure 2. Static strength of test beams.

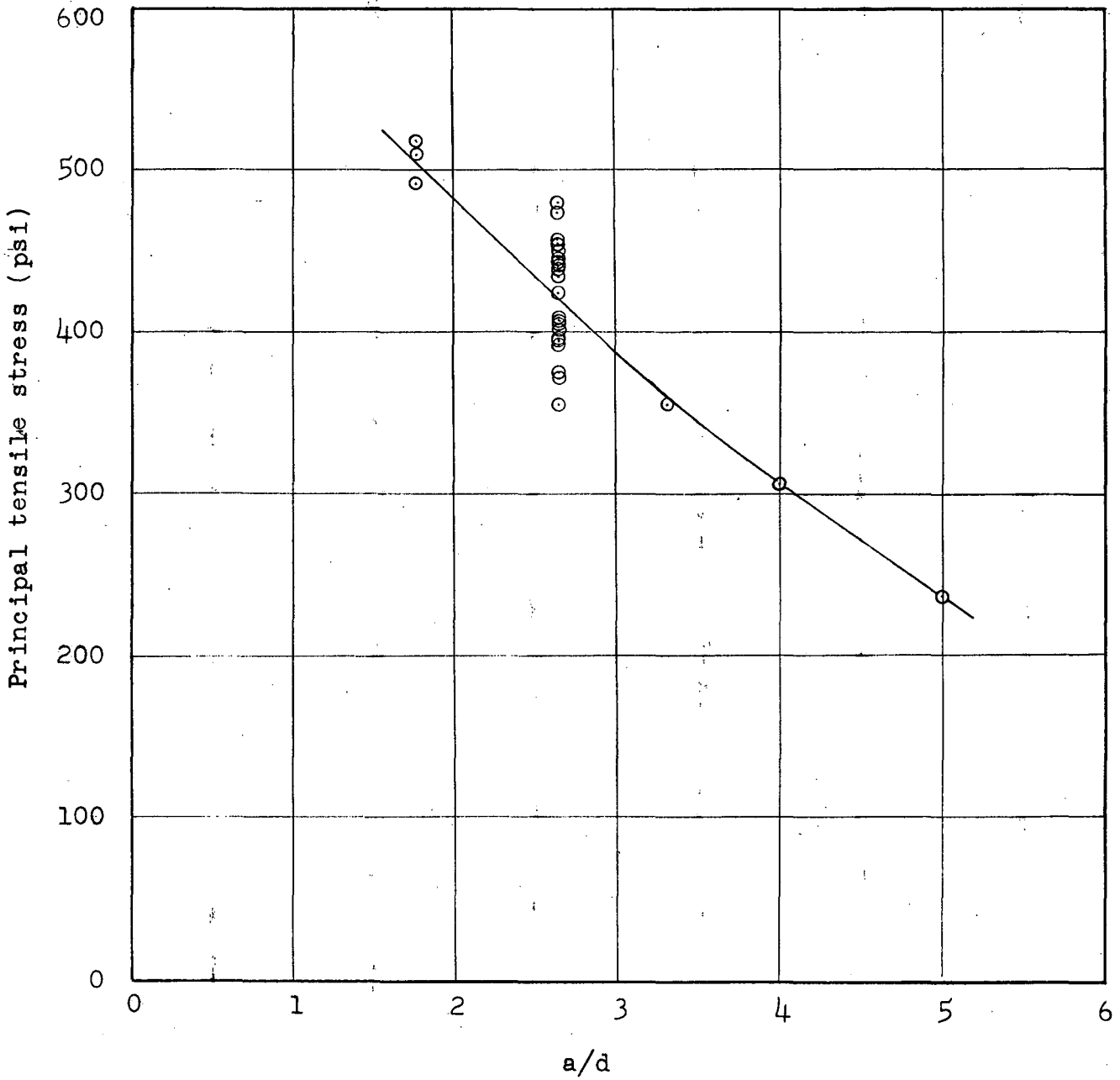

Figure 3. Principal tensile stress along C.G.C. at development of diagonal tension cracking.

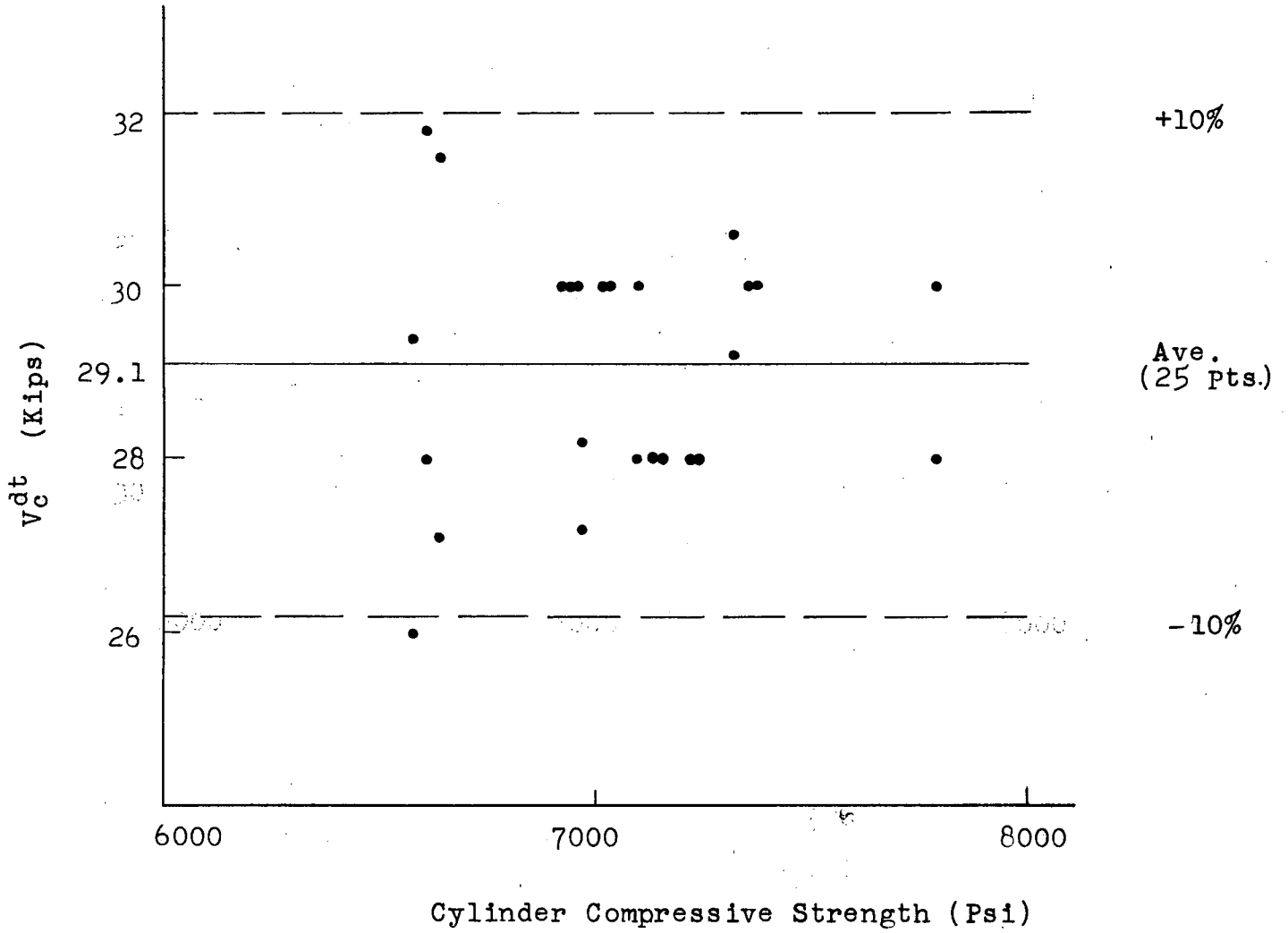

Figure 4. Variation of diagonal tension cracking load with concrete strength for $a/d = 3.39$.

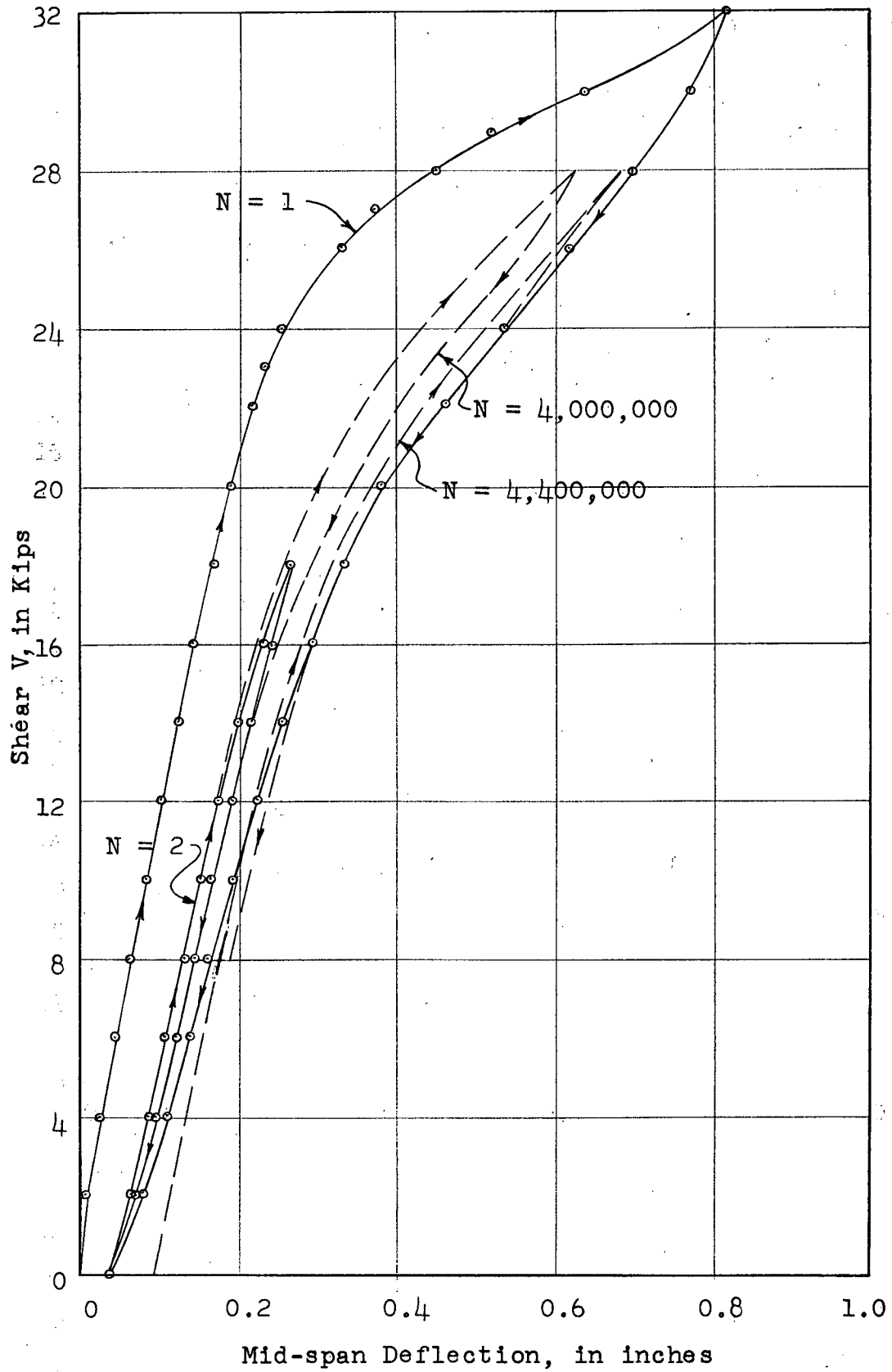

Figure 5. Load deflection curve for E.10

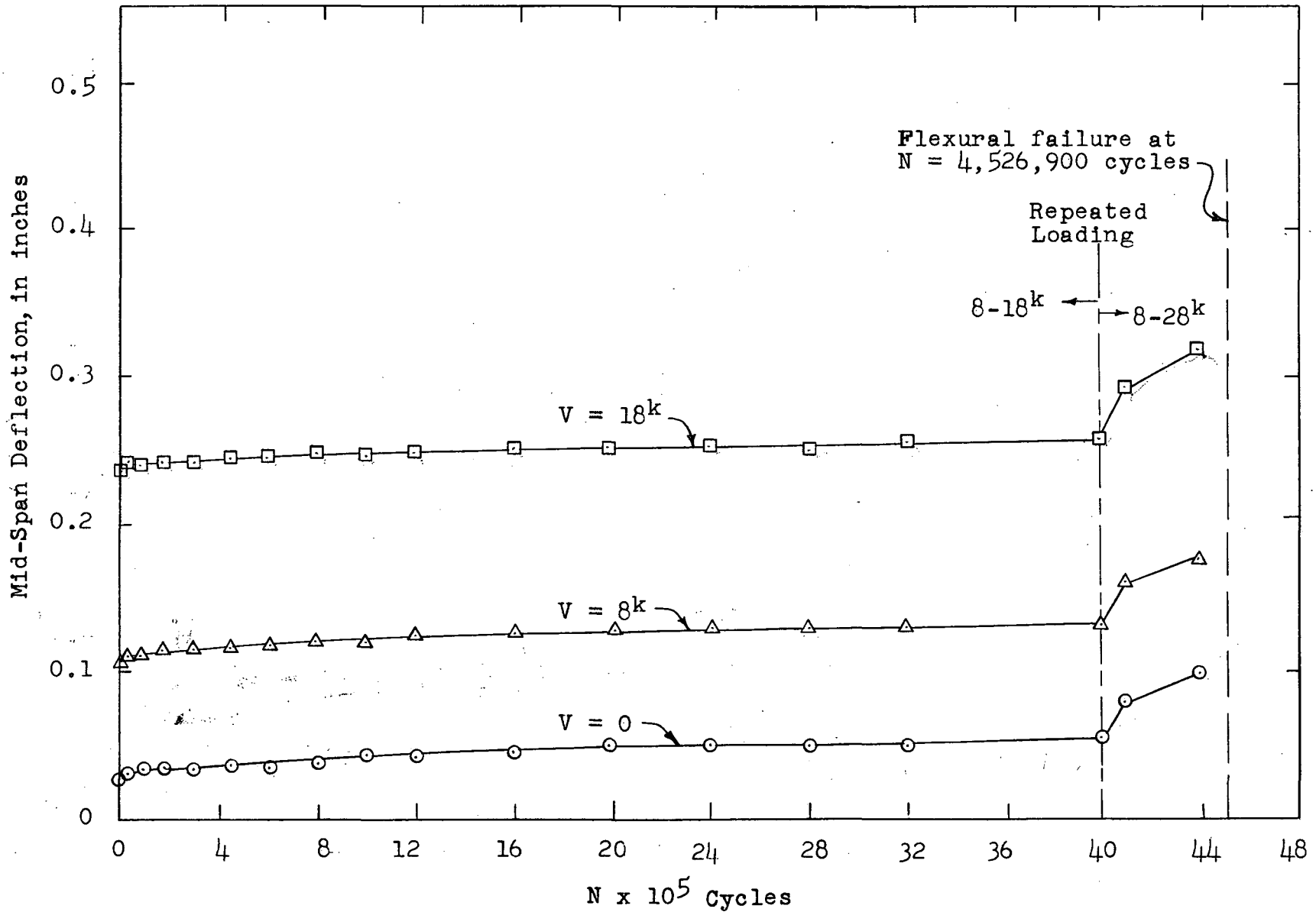

Figure 6. Deflection - N curve for E.10

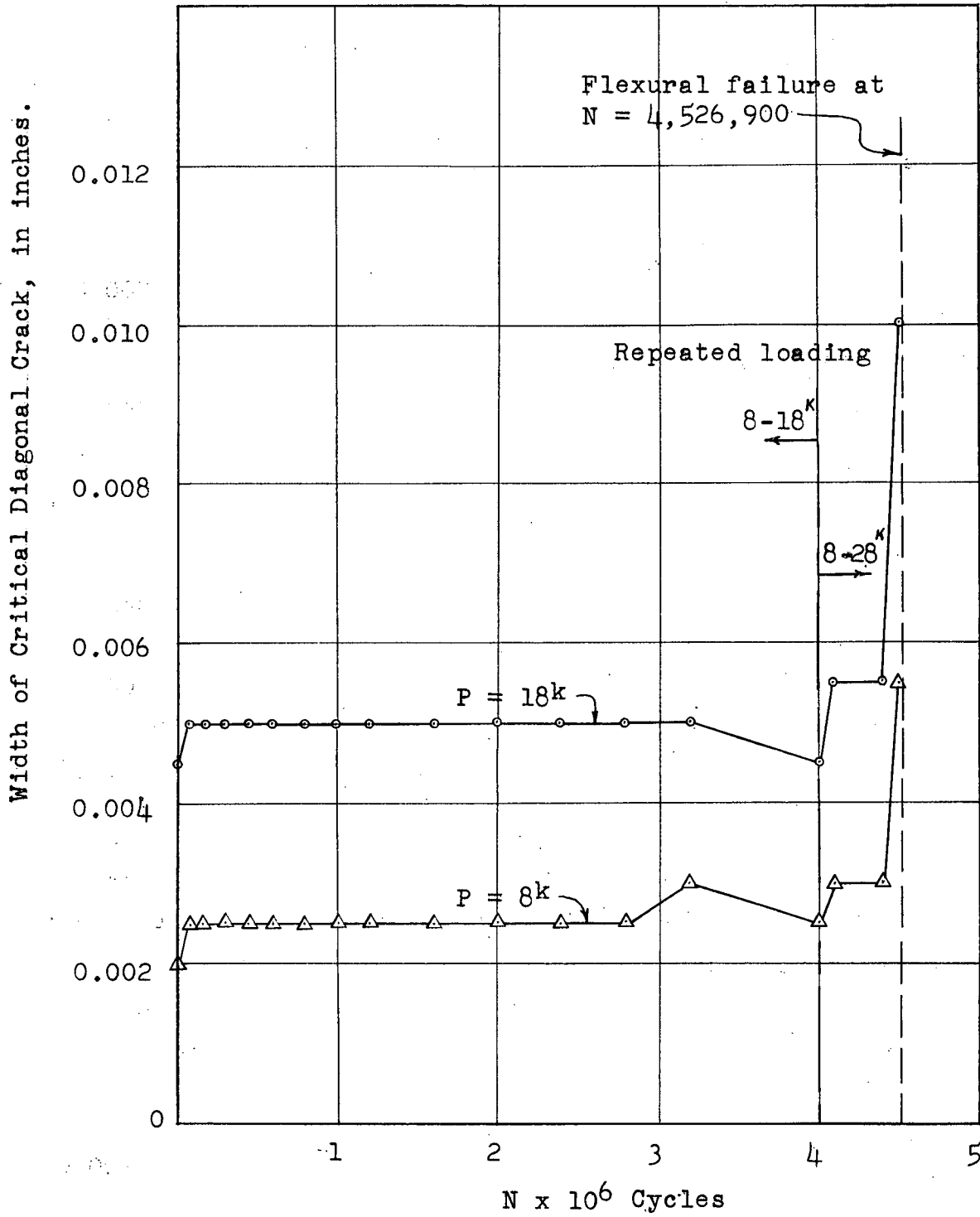

Figure 7. Variation in width of critical diagonal crack with N for E.10

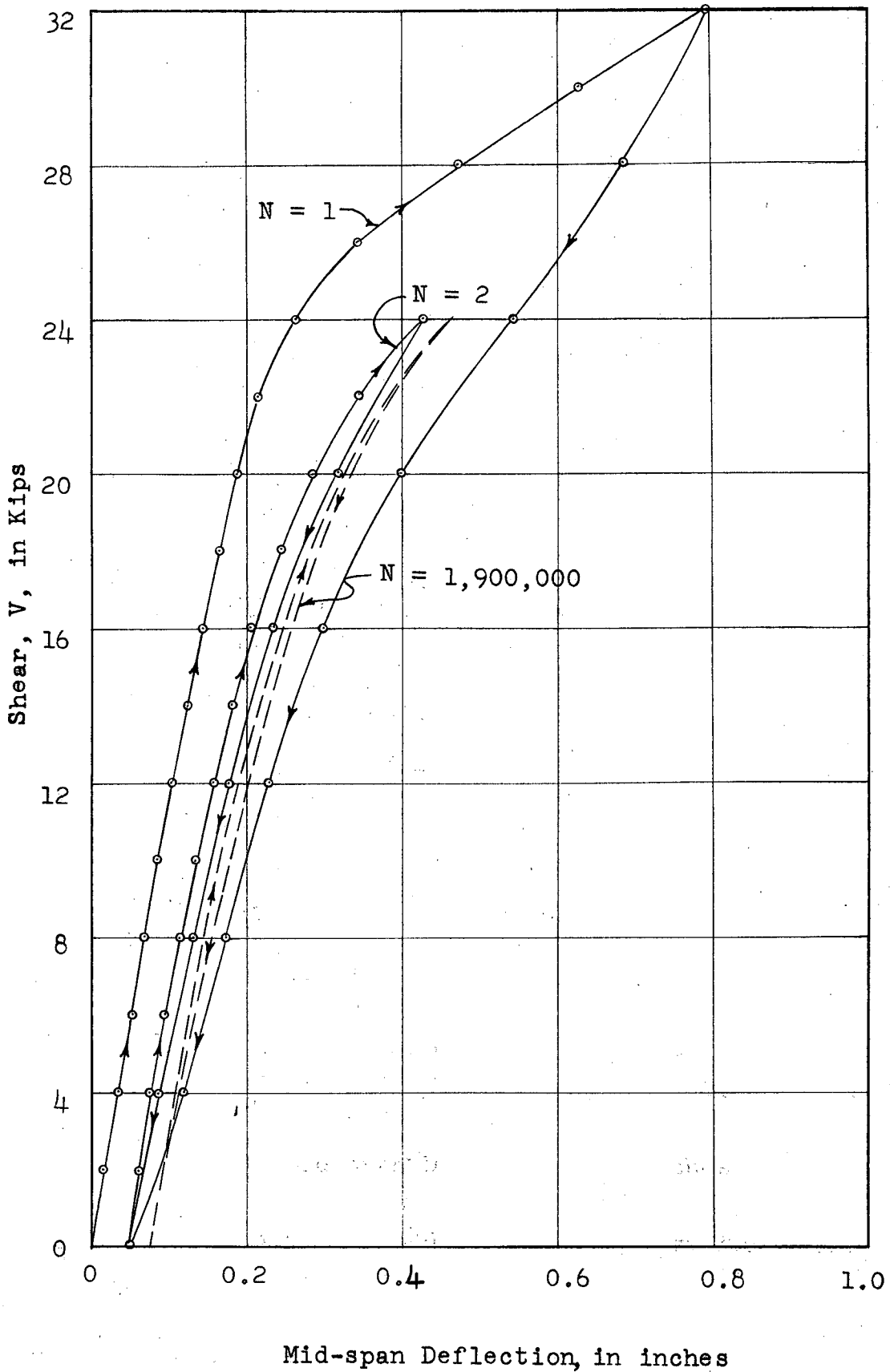

Figure 8. Load deflection curve for E.11.

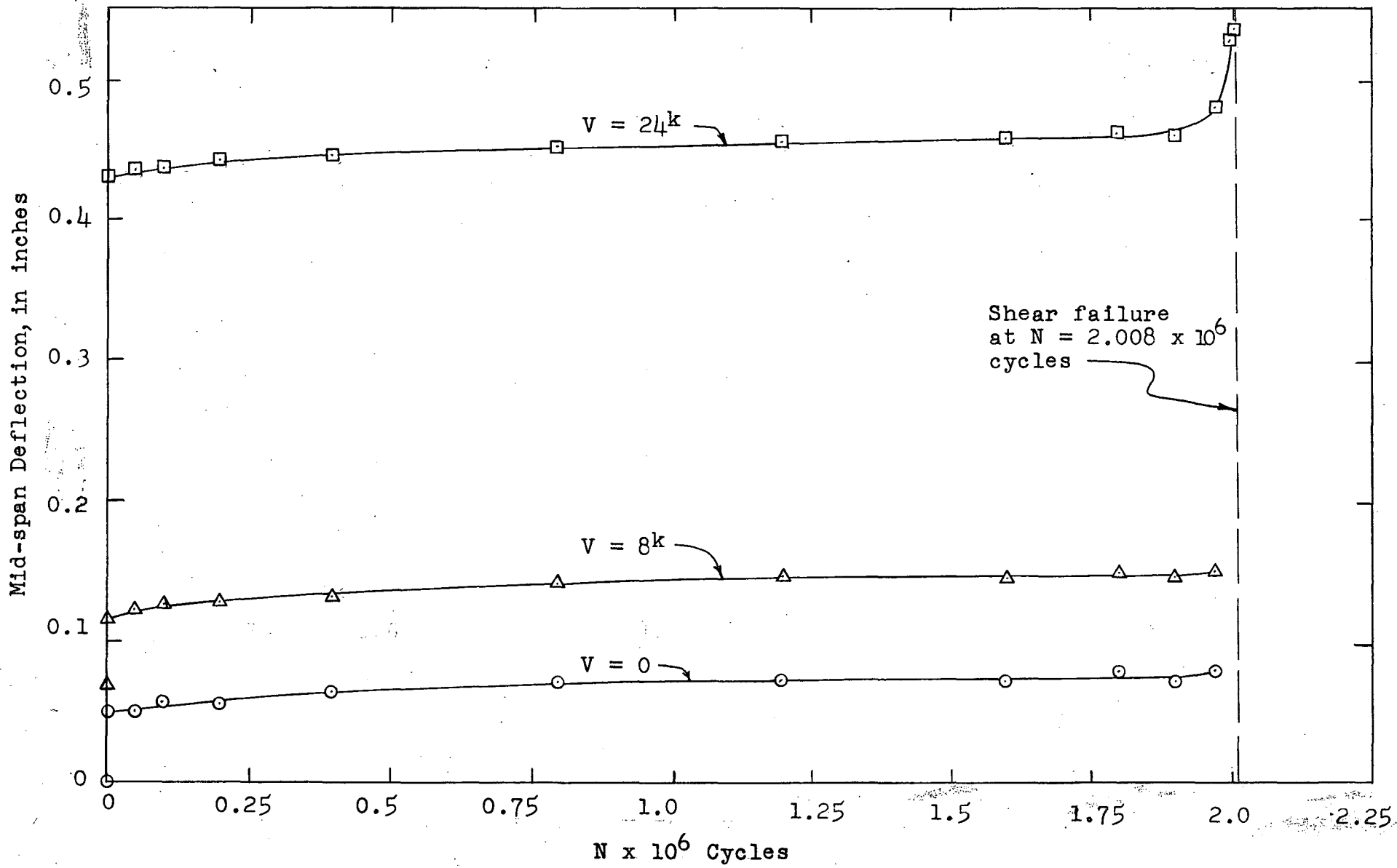

Figure 9. Deflection - N curve for E.11

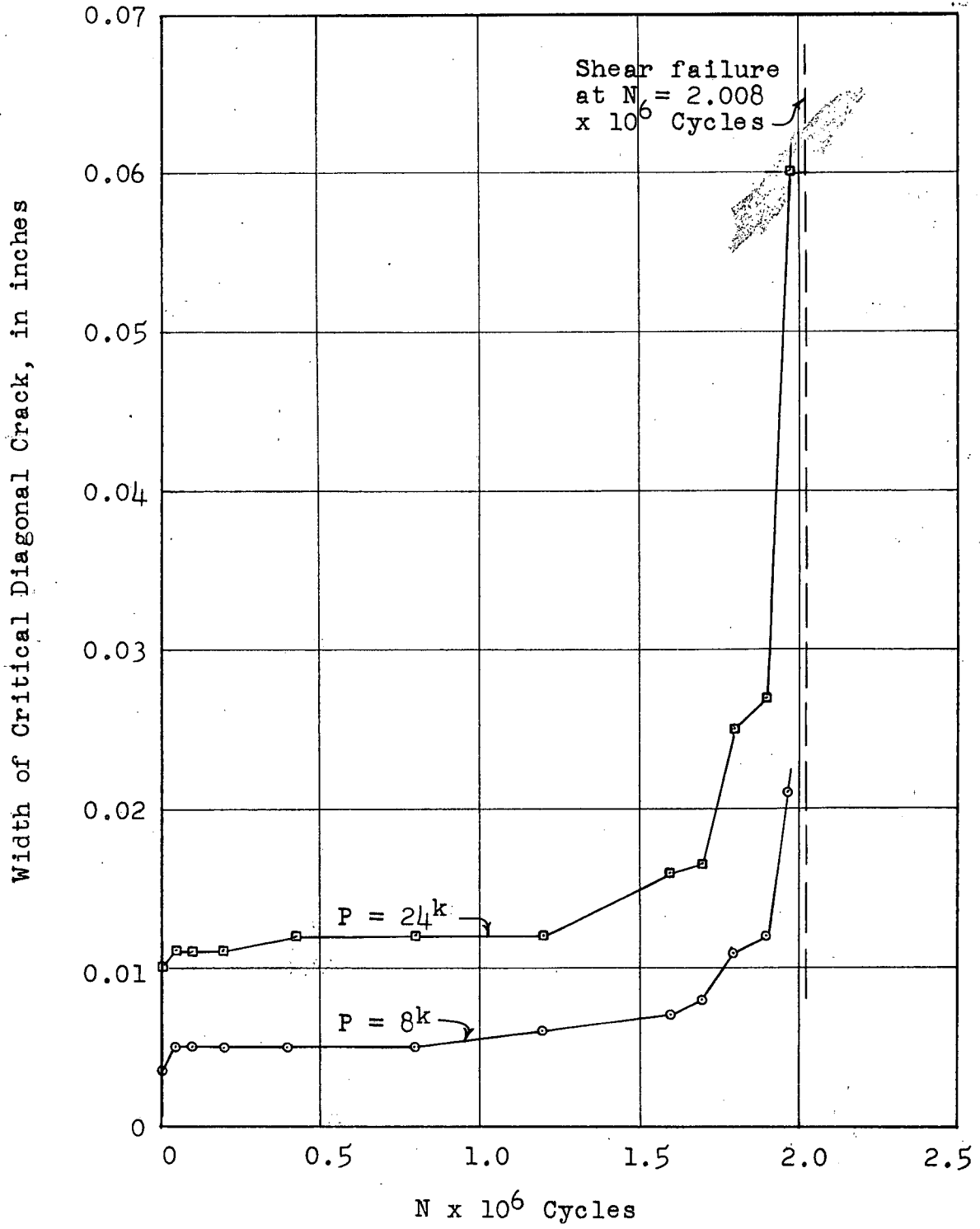
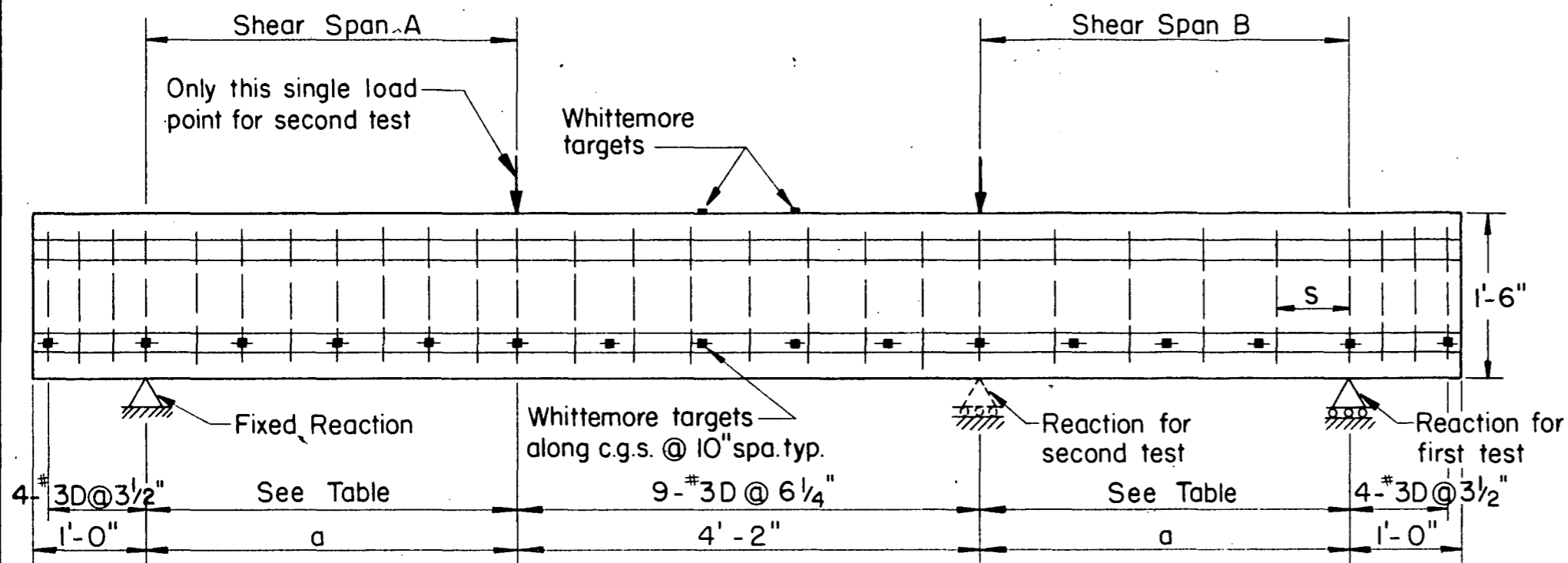
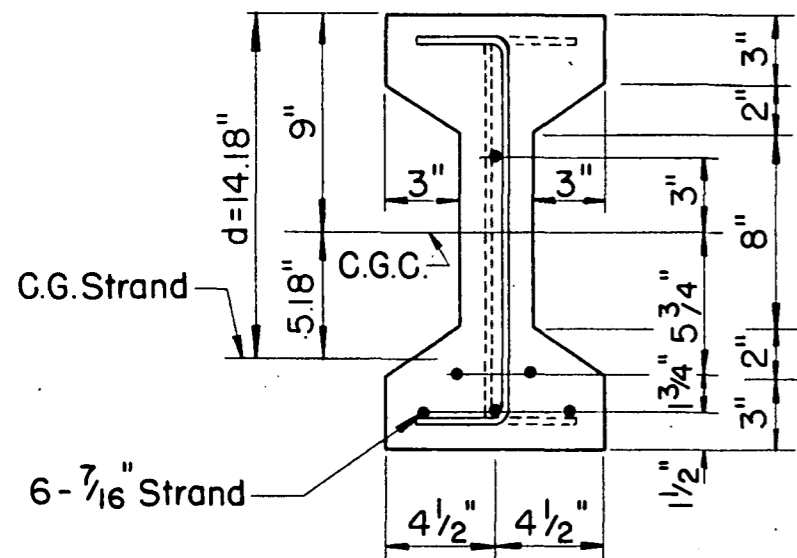

Figure 10. Variation in width of critical diagonal crack with N for E.11.



- Notes:**
- ELEVATION OF TEST BEAMS**
1. Point loaded test beam shown above. Details of uniformly loaded test beams similar.
 2. Dimension of 4'-2" between load points reduced to 2'-6" for F-14 and F-15, and to 1'-3" for F-16.



TEST BEAMS - UNIFORMLY LOADED					
Beam No.	Span	Web Reinf.			$\frac{r f_y}{100}$
F-17	10'-0"	1/4"		10"	97
F-18	10'-0"	3/16"		8"	46
F-19	15'-0"	#9		10"	23

TEST BEAMS-POINT LOADED							
Beam No.	Shear Span	Web Reinf.	a	$\frac{a}{d}$	s	r	$\frac{r f_y}{100}$
F-1	A	1/4"	30"	2.12	5"	0.328	193
	B	3/16"	30"	2.12	5"	0.184	74
F-2	A	1/4"	40"	2.82	5"	0.328	193
	B	1/4"	40"	2.82	8"	0.205	121
F-3	A	3/16"	40"	2.82	5"	0.184	74
	B	3/16"	40"	2.82	8"	0.115	46
F-4	A	1/4"	50"	3.52	6.25"	0.262	155
	B	1/4"	50"	3.52	8.33"	0.196	116
F-5	A	3/16"	50"	3.52	4.17"	0.220	88
	B	3/16"	50"	3.52	6.25"	0.147	59
F-6	A	#9	50"	3.52	5.55"	0.103	41
	B	#9	50"	3.52	10"	0.058	23
F-7	A	1/4"	60"	4.23	7.5"	0.218	129
	B	1/4"	60"	4.23	10"	0.163	97
F-8	A	3/16"	60"	4.23	5"	0.184	74
	B	3/16"	60"	4.23	6.67"	0.138	55
F-9	A	#9	60"	4.23	6"	0.096	38
	B	#9	60"	4.23	10"	0.058	23
F-10	A	3/16"	70"	4.93	4.12"	0.223	89
	B	3/16"	70"	4.93	5.83"	0.158	63
F-11	A	#9	70"	4.93	5.83"	0.099	40
	B	#9	70"	4.93	10"	0.058	23
F-12	A	3/16"	80"	5.63	5.33"	0.172	69
	B	3/16"	80"	5.63	7.26"	0.127	51
F-13	A	#9	80"	5.63	6.16"	0.093	37
	B	#9	80"	5.63	10"	0.058	23
F-14	A	3/16"	90"	6.34	7.5"	0.123	49
	B	#9	90"	6.34	6.43"	0.090	36
F-15	A	#9	90"	6.34	10"	0.058	23
	B	3/16"	90"	6.34	Varies		
F-16	A	#9	100"	7.05	10"	0.058	23
	B	3/16"	100"	7.05	Varies		
F-XI	A	1/4"	48"	2.54	8"	0.205	121
	B	1/4"	48"	2.54	8"	0.205	121

Figure 11

STRUCTURAL CONCRETE DIVISION
F TEST SERIES
 FRITZ ENGINEERING LABORATORY
 LEHIGH UNIVERSITY - BETHLEHEM, PA.

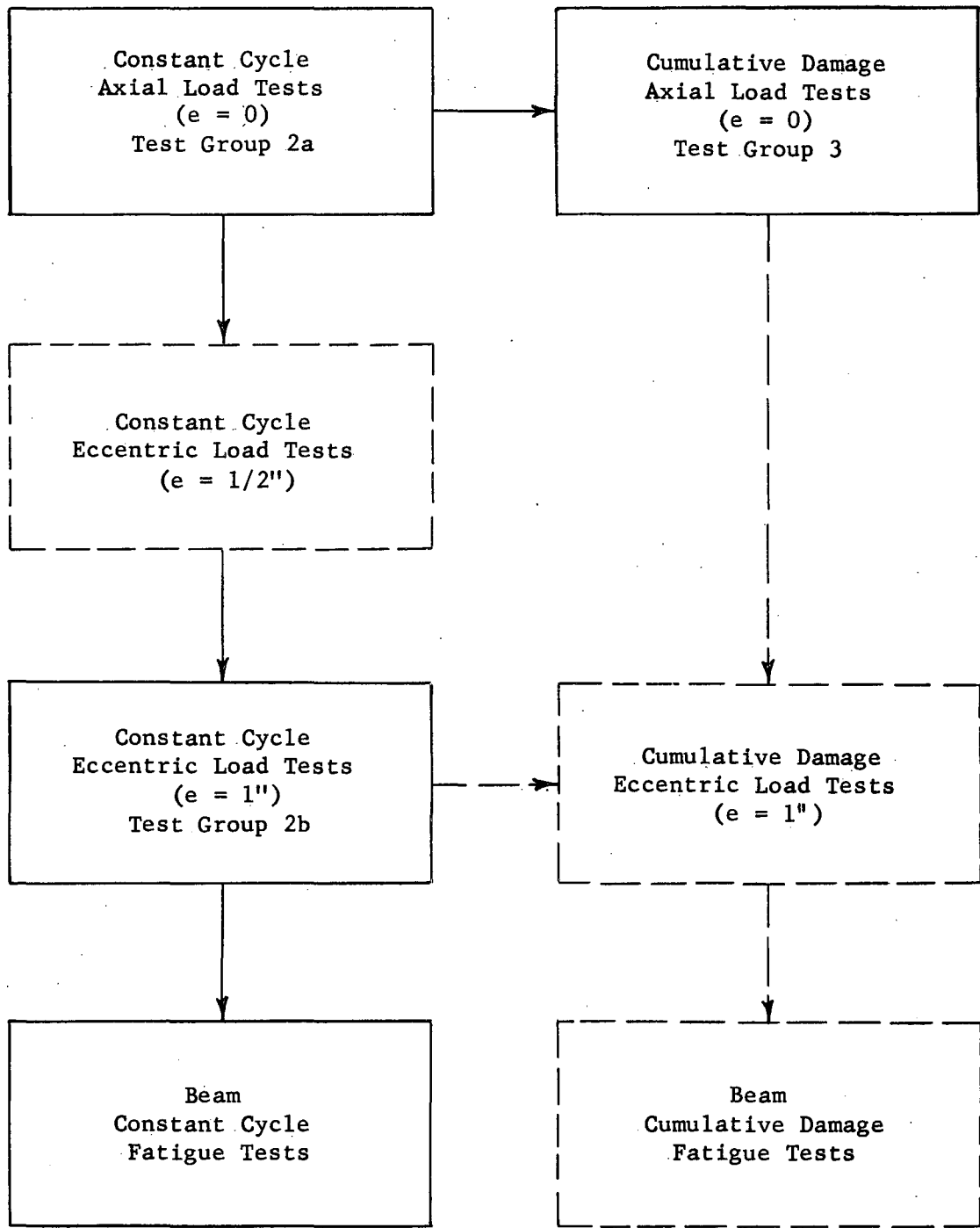

———— Proposed fatigue tests for 1962-63

- - - - Tests to be carried out only if time and availability of specimens allow

Figure 12. Proposed Fatigue Test Program

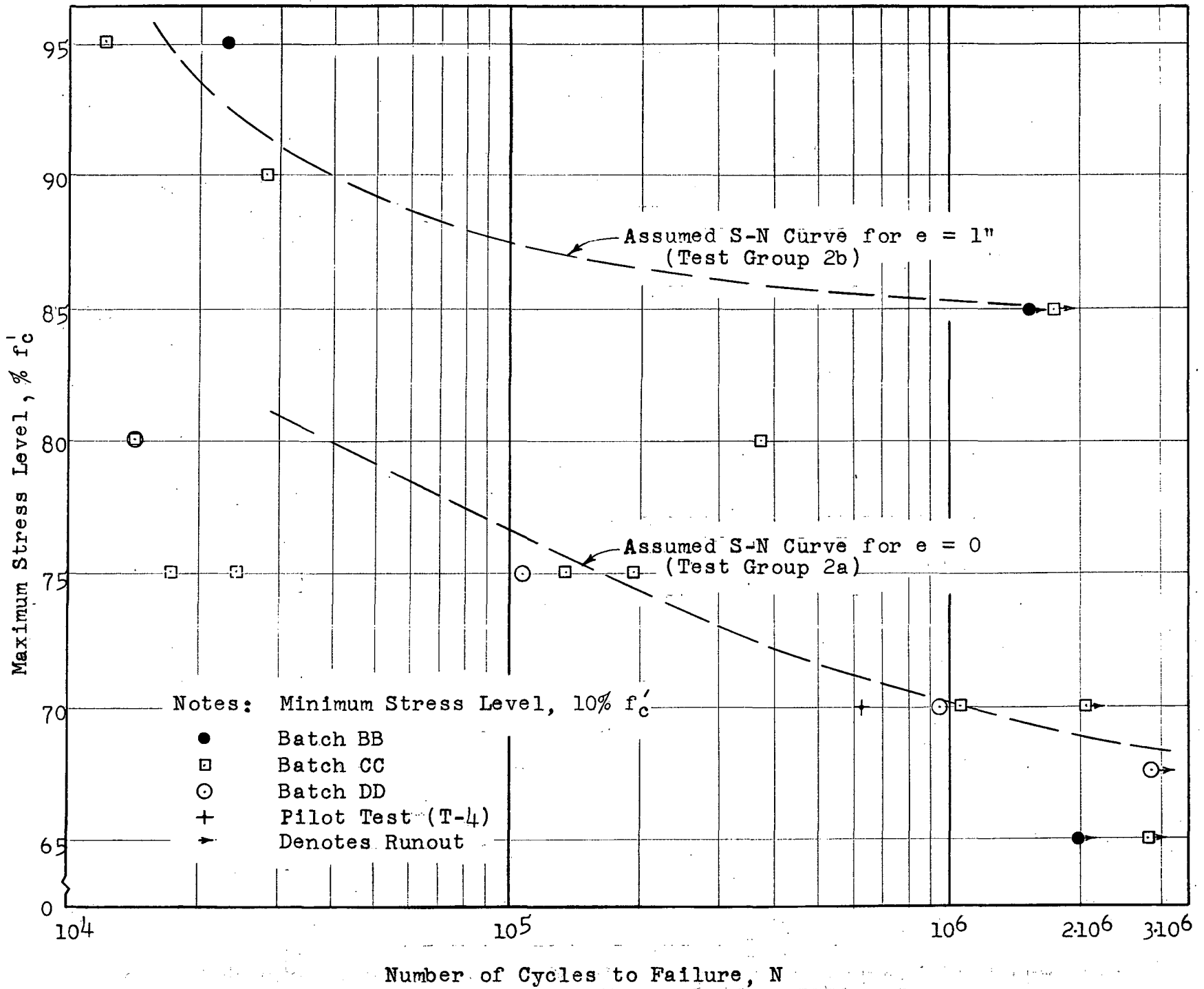

Figure 13. Upper Stress Level vs. Probable Fatigue Life