

1959

Repeated load tests on 7 wire prestressing strands, (Progress Report No. 21, Lehigh University, (January 1959))

R. E. Lane

C. E. Ekberg Jr.

Follow this and additional works at: <http://preserve.lehigh.edu/engr-civil-environmental-fritz-lab-reports>

Recommended Citation

Lane, R. E. and Ekberg, C. E. Jr., "Repeated load tests on 7 wire prestressing strands, (Progress Report No. 21, Lehigh University, (January 1959))" (1959). *Fritz Laboratory Reports*. Paper 1523.
<http://preserve.lehigh.edu/engr-civil-environmental-fritz-lab-reports/1523>

This Technical Report is brought to you for free and open access by the Civil and Environmental Engineering at Lehigh Preserve. It has been accepted for inclusion in Fritz Laboratory Reports by an authorized administrator of Lehigh Preserve. For more information, please contact preserve@lehigh.edu.

PRESTRESSED CONCRETE BRIDGE MEMBERS

PROGRESS REPORT 21

REPEATED LOAD TESTS
ON 7-WIRE
PRESTRESSING STRANDS

by

Richard E. Lane
and
Carl E. Ekberg, Jr.

FRITZ ENGINEERING LABORATORY

LEHIGH UNIVERSITY

BETHLEHEM, PA.

JANUARY, 1959

ACKNOWLEDGMENTS

This work was performed through the Institute of Research of Lehigh University under the sponsorship of the following organizations:

Pennsylvania Department of Highways

U.S. Bureau of Public Roads

John A. Roebling's Sons Corporation

American Steel and Wire, Div. of U.S. Steel Corp.

Reinforced Concrete Research Council

American-Marietta Company, Concrete Products Division

Lehigh University

The investigation was carried out at the Fritz Engineering Laboratory under the administrative direction of Professor William J. Eney. Professor Samuel J. Errera, Director of Tests, was responsible for scheduling of the test equipment.

Acknowledgment is also due to Mr. K. R. Harpel, laboratory foreman, and his staff of technicians who prepared the testing equipment and specimens; and to Mr. I. J. Taylor and the instruments group for guidance and aid in instrumentation.

Special appreciation is due Mr. Bryce H. Baldwin who assisted not only in the testing operation but in the reduction and plotting of data as well.

Mrs. Lane typed the final draft of this report while Miss E. Young and Mrs. F. Cataneo prepared the copy for reproduction.

CONTENTS

| <u>Chapter</u> | | <u>Page</u> |
|---------------------|--|-------------|
| I | INTRODUCTION | 1 |
| II | BRIEF SURVEY OF LITERATURE | 4 |
| III | EXPERIMENTAL INVESTIGATION | 18 |
| | Preparation of Specimens | 18 |
| | Testing Equipment | 24 |
| | Testing Procedure | 28 |
| | Test Results and Observations | 30 |
| IV | APPLICATION OF THE FATIGUE ENVELOPE TO BEAM DESIGN | 50 |
| | CONCLUSION | 53 |
| <u>Appendix</u> | | |
| A | CREEP CURVES FOR 7/16" STRANDS UNDER REPEATED LOADING | 54 |
| B | PHOTOGRAPHS OF TYPICAL FATIGUE AND STATIC FAILURES | 58 |
| C | POSSIBLE PROCEDURE FOR ELIMINATING INACCURACIES DUE TO SLIP | 61 |
| | BIBLIOGRAPHY | 70 |

ILLUSTRATIONS

| <u>Figure</u> | | <u>Page</u> |
|---------------|---|-------------|
| 1 | FATIGUE FAILURE ENVELOPE FOR PRE-STRESSING STEEL | 9 |
| 2 | CREEP TESTS ON .196" DIAM. HOT GALVANIZED BRIDGE WIRE | 13 |
| 3 | CREEP CURVES FOR STATIC AND OSCILLATING LOADING UNDER VARIOUS PRE-TENSIONS FOR STEEL A IN THE HEAT-TREATED CONDITION (BY RUDOLPH ZINSSER) | 16 |
| 4 | CREEP CURVES FOR STATIC AND OSCILLATING LOADING (STEEL D HEAT TREATED) BY ZINSSER | 17 |
| 5 | COMPONENT PARTS OF A TYPICAL SPECIMEN | 18 |
| 6 | A TYPICAL SPECIMEN | 19 |
| 7 | TENSIONING APPARATUS | 22 |
| 8 | THE GROUTING OPERATION | 23 |
| 9 | STRUCTURAL FRAMEWORK | 25 |
| 10 | CLIP GAGES FOR MEASURING CREEP | 27 |
| 11 | A TEST IN PROGRESS | 28 |
| 12 | SPECIMEN JUST PRIOR TO TESTING | 29 |
| 13 | S-N CURVE FOR MINIMUM STRESS OF 54.5% OF STATIC ULTIMATE | 39 |

ILLUSTRATIONS (CONTINUED)

| <u>Figure</u> | | <u>Page</u> |
|---------------|--|-------------|
| 14 | S-N CURVE FOR MINIMUM STRESS OF 65.2% OF STATIC ULTIMATE | 40 |
| 15 | S-N CURVE FOR MINIMUM STRESS OF 55.6% OF STATIC ULTIMATE BY F.S. NUWAYSIR | 41 |
| 16 | VERIFICATION OF FATIGUE FAILURE ENVELOPE | 43 |
| 17 | DIAGRAM OF BEAM DIMENSIONS | 51 |
| 18 | CREEP CURVE DUE TO REPETITIVE LOADING OF 54.5-68.0% OF STATIC ULTIMATE | 55 |
| 19 | CREEP CURVES DUE TO REPETITIVE LOADING WITH A CONSTANT MINIMUM STRESS OF 65.2% OF STATIC ULTIMATE AND VARYING MAXIMUM STRESSES | 56 |
| 20 | CREEP CURVE DUE TO REPETITIVE LOADING OF 50-60% OF STATIC ULTIMATE | 57 |
| 21 | FAILURES OF SPECIMEN NOS. 32, 33, 36 | 59 |
| 22 | FAILURES OF SPECIMEN NOS. 37-39 | 59 |
| 23 | FAILURES OF SPECIMEN NOS. 40-42 | 60 |
| 24 | FAILURES OF SPECIMEN NOS. 43-45 | 60 |
| 25 | RETAINING RING CLAMP | 62 |
| 26 | RELATED VIEWS OF DISK SLIP CORRECTION METHOD | 64 |
| 27 | RELATED VIEWS OF LIGHT SLIP CORRECTION METHOD | 67 |

TABLES

| <u>Number</u> | | <u>Page</u> |
|---------------|---|-------------|
| I | RESULTS OF STEEL FATIGUE TESTS (BY F. S. NUWAYSIR) | 11 |
| II | RECORDED DATA FOR STRAND FATIGUE AND CREEP TESTS | 32 |
| III | REMARKS PERTAINING TO TABLE II | 36 |
| IV | STRESS MOMENT RELATIONSHIPS | 52 |

CHAPTER IINTRODUCTION

In the United States today there are some one hundred systems of prestressing utilizing several different forms of high strength prestressing steel. One of the more widely used of these tendons is the 7-wire strand. It is the purpose of this report, therefore, to determine the fatigue strength and the dynamic creep curves for 7/16" and 3/8" diameter 7-wire uncoated stress-relieved prestressing strands manufactured by the John A. Roebling's Sons Corporation, Trenton, New Jersey. The fatigue strength will be expressed both as S-N curves for typical minimum stresses (the amount of prestress of a strand in a beam being taken as the minimum stress) and as a fatigue failure envelope for one million cycles.

The field of prestressed concrete is still in its early stages in the United States today. Its use, up to this time, has been rather limited. This is not to say, however, that the number of structures in which prestressed concrete forms an intricate part is small or that its use is to be limited in the future. On the contrary, prestressed concrete is being used today in ever-widening areas and in an ever increasing number of structures. So great is the increase in usefulness of this construction material, that research and design methods are lagging behind the actual construction in many cases.

With the ever-increasing usefulness of this material, therefore, comes an increasing need for research to solve the many problems discovered in these new methods and uses. Yet many of the basic problems found in some of the elementary forms of prestressed concrete remain unsolved. It is the purpose of this report to attempt to clarify two such basic problems found in most of the forms of prestressed concrete in use today, namely, the problem of fatigue and that of creep. It is hoped that this report will pave the way for additional research work and presentation of further information in related areas.

In most cases of prestressed concrete structures in use today, certain repetitive loadings occur in addition to the normal static loads. Within the range of everyday use, a small percentage of these repetitive loadings produce stresses above those for which the member was designed. These repetitive overloads tend to form small cracks in the tension zone of the member, thus placing a tension-tension type of repetitive loading on the prestressing material.

This loading may have two effects on the member. First, if the amplitude of loading is great enough and the repetitions of overload numerous enough, the member may fail prematurely due to fatigue of the prestressing steel. This type of failure is very sudden, giving no warning before the actual break occurs, and should be avoided through proper design.

Secondly, creep in the steel caused by this repetitive loading, may form ever widening cracks, thus causing an undesirable increase in member deflection. With the proper knowledge of this phenomenon, this bad effect may also be avoided through careful design. However, there is very little information available on either of these two important phenomena to enable the designer to make a design that is both safe and economical in these areas.

CHAPTER II

BRIEF SURVEY OF LITERATURE

The design of prestressed concrete members is based primarily on a study of maximum static loadings to which a structure might possibly be subjected. CRITERIA FOR PRESTRESSED CONCRETE BRIDGES¹ by the Bureau of Public Roads, for instance, states that the ultimate resisting moment of a beam must be strong enough to withstand Dead Load + 3 (Live Load + Impact Load) or 2 (Dead Load + Live Load + Impact Load). TENTATIVE RECOMMENDATIONS FOR PRESTRESSED CONCRETE² by the ACI-ASCE Joint Committee, states that this ultimate strength must exceed 1.5 Dead Load + 2.5 Live Load for highway bridges. Both of these codes present ultimate design formulas in terms of loadings which are expressed in a static nature. However, in bridges and other structures of a similar nature, for which prestressed concrete members may be used, the loadings are of a repetitive nature.

Through the use of simple static tests, much is known about the static strength and other properties of prestressed concrete. However, little is known about the dynamic resistance to loading or of other properties particularly applicable to repetitive loadings.

- - - - -

1. Bureau of Public Roads, CRITERIA, p. 14
2. ACI-ASCE Joint Committee 323, TENTATIVE RECOMMENDATIONS FOR PRESTRESSED CONCRETE, Journal ACI, 29:552

T. Y. Lin notes that the fatigue strength of prestressed concrete may be studied from three approaches: "That of concrete itself, that of high tensile steel, and that of the combination of both."¹ Much of the research work that has been done on the investigation of fatigue properties of prestressed concrete has been done on this third approach, that of the combination of steel and concrete.

One of the first of these was an endurance test on hollow prestressed concrete telephone poles by Freyssinet² in 1934. Then followed repeated load tests on prestressed composite slabs by Campus and Abeles³ in 1951.

In 1952 Inomata⁴ dynamically tested 24 prestressed concrete beams, and in the following year Magnel⁵ tested two prestressed concrete T-beams. Additional repeated load tests, this time on prestressed concrete beams, were reported by Abeles in 1954⁶.

-
1. Lin, DESIGN OF PRESTRESSED CONCRETE STRUCTURES, p. 410
 2. Freyssinet, A REVOLUTION IN THE TECHNIQUES OF THE UTILIZATION OF CONCRETE, Structural Engineer, Vol. 29
 3. Abeles, SOME NEW DEVELOPMENTS IN PRESTRESSED CONCRETE, Structural Engineer, Vol. 29
 4. Inamata, ON A BENDING FATIGUE TEST OF PRESTRESSED CONCRETE BEAMS, Journal JSCE, Vol. 37
 5. Magnel, NOUVEL ESSAI DE FATIGUE D'UNE POUTRE EN BETON PRECONTRAINTE, Science et Technique, Vol. 8
 6. Abeles, FATIGUE RESISTANCE OF PRESTRESSED CONCRETE BEAMS, Final Report, IABSE

T. Y. Lin¹ in 1955, ran comparative static and repeated load tests on two prestressed concrete two-span continuous beams. Other tests by Ozell and Ardaman² on eight pretensioned prestressed concrete beams, and by Eastwood³ on twelve post-tensioned prestressed concrete beams were also run.

At Lehigh University, Knudsen and Eney⁴ reported on the endurance test of a full size pretensioned concrete beam in 1943, and in 1954 Smislova, Roesli, Brown, and Eney⁵ tested the endurance of a full scale post-tensioned prestressed concrete beam.

With these tests comprising the majority of repeated load tests in prestressed concrete over the period of time shown, it becomes obvious to the reader that a great deal of information was still to be obtained. Even less data had been obtained in either of the other two areas of approach to this problem of fatigue strength as outlined by Lin.

- - - - -
1. Lin, STRENGTH OF CONTINUOUS PRESTRESSED CONCRETE BEAMS UNDER STATIC AND REPEATED LOADS, Proceedings ACI, Vol. 51
 2. Ozell and Ardaman, FATIGUE TESTS OF PRETENSIONED PRESTRESSED BEAMS, Journal ACI, Vol. 28
 3. Eastwood, FATIGUE TESTS ON LEE-McCALL PRESTRESSED CONCRETE BEAMS, Civil Eng'g. and Public Works Review, Vol. 52
 4. Knudsen and Eney, ENDURANCE OF FULL SCALE PRETENSIONED CONCRETE BEAM
 5. Smislova and others, ENDURANCE OF A FULL SCALE POST-TENSIONED CONCRETE MEMBER

In the area of high strength steel, tests which have been reported are almost entirely on wires or bars. One such report is that by Shelton and Swanger¹ on the fatigue properties of high strength steel wire. In this study the heat treated and the cold drawn wires are treated individually and compared.

There is, however, almost no available data on the fatigue strength of strands. The strand is in abundant use in the United States today, and yet so little is known about the action of the strand as a unit in the repeated load case.

Dr. Hempel has this to say about wire ropes: "To evaluate the qualities and the properties of the steel wires, it is certainly convenient to carry out fatigue tests on single wires, but fatigue tests on rope sections are indispensable for evaluating the behavior of the wire in the rope. This applies in particular to methods of finding the effects of free and restricted rotation of the rope in constant operation on its life, and the methods of obtaining data on the symptoms indicating that a wire rope in service is no longer economical or safe"². This same reasoning should also apply to such a similar product as prestressing strand.



1. Shelton and Swanger, FATIGUE PROPERTIES OF STEEL WIRE, Journal of Research of the National Bureau of Standards, Vol. 14

2. Hempel, FATIGUE TESTS ON STEEL WIRE, Draht, 23:30

With this in mind, investigators at Lehigh University searched for a method by which the action of the strand in a prestressed concrete member under repeated loading could be predicted. In 1957 Ekberg, Walther, and Slutter¹, reported on a method for prediction of fatigue failures for prestressed concrete beams in bending. This method utilizes a combined diagram, part of which is a modified Goodman-Johnson fatigue failure envelope for prestressing steel (see Figure 1) obtained from the work of Ros². This envelope indicates how much the stress can be increased from a given minimum level to obtain a failure at one million load cycles. It should be noted that the ordinates and abscissas of this curve are given as percentages of the static ultimate strength of the prestressing steel. It can be seen, for example, that the steel may resist one million repetitions of a range of stress amounting to 28 per cent of static tensile strength if the minimum stress is zero, but only an 18 per cent range of stress if the minimum stress is increased to 40 per cent.

Slutter and Ekberg³ tested six prestressed concrete beams, three of them with repeated loads, and these seemed to verify this fatigue failure envelope for steel as well as the combined diagram method of solution already mentioned.

- - - - -
1, Ekberg, Walther, and Slutter, FATIGUE RESISTANCE OF PRESTRESSED CONCRETE BEAMS IN BENDING, Journal of the Structural Division A.S.C.E., Vol. 83

2, Ros, VORGESPANNTER BETON, EMPA, 155:79, Fig. 78

3. Slutter and Ekberg, STATIC AND FATIGUE TESTS ON PRESTRESSED CONCRETE RAILWAY SLABS

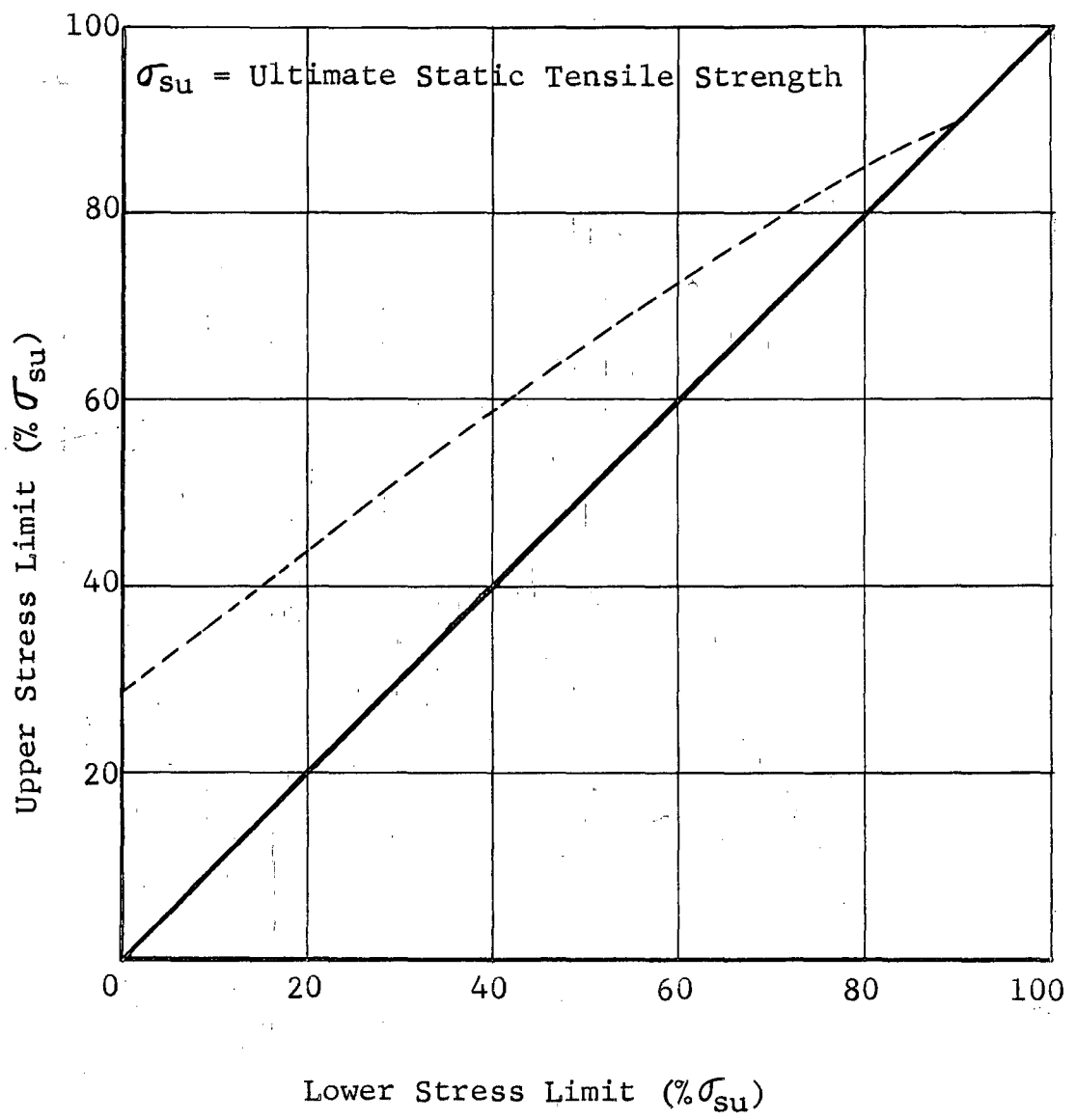

FIGURE 1 - FATIGUE FAILURE ENVELOPE FOR PRESTRESSING STEEL
(10^6 cycles)

However, further verification was needed, especially a detailed investigation of the fatigue failure envelope for prestressing steel as it would apply to high strength steel strands. In 1956 a series of pilot tests were conducted by F. S. Nuwaysir¹ to determine the best methods for testing strands and to attempt to aid in verification of this envelope. A summary of his test results appears in Table I. These tests led to the more detailed investigation reported here.

Another area where there is little knowledge is in the field of creep of the high strength prestressing steel. There is some data available for the static case, and in this situation it seems to be the more important case. Due to the nature of the creep phenomenon, the greatest part of the creep strains seem to occur during the first few hours when the loading on the prestressing tendons is a static one (only the prestress force). However, creep does continue for a long period of time and then creep under repeated loading conditions becomes a factor. On this phenomenon there seems to be almost no information.

- - - - -

1. Nuwaysir, FATIGUE STUDY OF PRESTRESSED CONCRETE BEAMS AND THEIR COMPONENTS
2. Godfrey, STEEL WIRE FOR PRESTRESSED CONCRETE, Proceedings of First U.S. Conference on Prestressed Concrete, p. 150

Table I - Results of Steel Fatigue Tests
(by F.S. Nuwaysir)

| Specimen Number | Applied Cycles Millions | Load-kips | | Per cent f'_s | | Remarks |
|--------------------|-------------------------------|-----------|------|-----------------|------|---------------------------------------|
| | | Min. | Max. | Min. | Max. | |
| 1 | 1.4842 | 4 | 10 | 14.8 | 37.1 | F |
| 2 | 1.6831 | 10 | 15 | 37.1 | 55.6 | NF |
| 3 | 2.2367 | 10 | 15 | 37.1 | 55.6 | NF |
| 4 | 1.1080 | 14 | 18 | 51.9 | 66.7 | F |
| 5 | 0.2940 | 14 | 19 | 51.9 | 70.4 | F |
| 6 | 5.1555 | 15 | 18 | 55.6 | 66.7 | NF stat. ult. = 30k yield = 28k |
| 7 | 1.3172 | 15 | 19 | 55.6 | 70.4 | F |
| 8 | 2.082 | 15 | 19 | 55.6 | 70.4 | NF |
| 9 | 1.4465 | 15 | 19 | 55.6 | 70.4 | F |
| 10 | 1.4690 | 15 | 19 | 55.6 | 70.4 | NF |
| 11 | 1.1470 | 20 | 25 | 55.6 | 70.4 | F 1/2-in. strand |
| 12 | 1.3600 | 20 | 25 | 55.6 | 70.4 | F 1/2-in. strand |
| 13 | 0.8610 | 15 | 20 | 55.6 | 74.1 | F |
| 14 | 0.3521 | 15 | 21 | 55.6 | 77.9 | F |
| 15 | 1.9010 | 24 | 26 | 89.0 | 96.4 | F |

F = Failed

NF = No Failure

Note: All strands are of 7/16-in. nominal diameter unless
otherwise designated; f'_s is assumed to be 250 000 psi

In 1951, H. J. Godfrey¹ reported on static loading creep studies carried out at the John A. Roebling's Sons Laboratories. One important fact brought out by this report is that creep does continue for a very long period of time when stresses in the high strength steel are extremely high. "Although short time creep tests may indicate that the rate of creep soon diminishes to a very small value, long time tests on cold drawn hot galvanized bridge wire show that when the stresses are extremely high, the amount of creep continues for a considerable length of time".¹ Figure 2 is taken from Mr. Godfrey's report.

In discussion of Mr. Godfrey's work, Eney and Loewer² stated that for the long time creep characteristics, high overloads could be tolerated provided they were low in frequency and provided the stress in the tendons was not extremely high before overload. They also expressed the need for data on the creep of entire strands.

In added discussion of Mr. Godfrey's work, Everling states: "Analyzing the data so far presented, we must recognize that stress-relieved hard drawn high tensile wire is substantially free of creep only if the working stress does not materially exceed 50 per cent of ultimate strength"³.

1. Godfrey, STEEL WIRE FOR PRESTRESSED CONCRETE, Proceedings of First U.S. Conference on Prestressed Concrete, p.150
2. Eney and Loewer, STEEL WIRE FOR PRESTRESSED CONCRETE-DISCUSSION, Proceedings of First U.S. Conference on Prestressed Concrete, p. 158
3. Everling, STEEL WIRE FOR PRESTRESSED CONCRETE-DISCUSSION, Proceedings of First U.S. Conference on Prestressed Concrete, p. 162

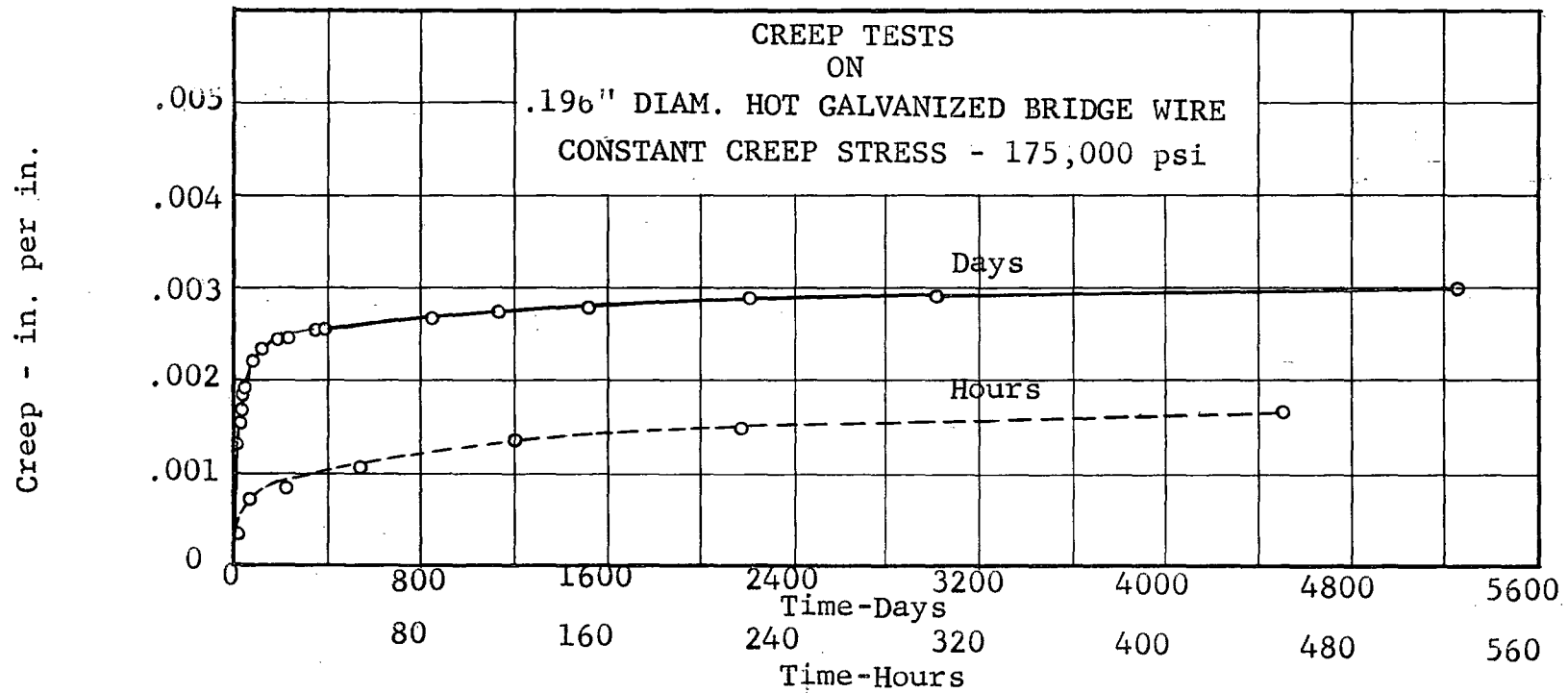

FIGURE 2

All this seems to indicate that creep may continue for a long enough time such that a possible increase of creep due to repetitive loading becomes a factor. On this phase of creep T. Y. Lin has this to say: "The question has sometimes been raised as to the possibility of excessive creep under repeated loads. But, so far as available evidence from fatigue tests shows, no such creep need be feared for the ordinary range and duration of stress to which the wire is subject"¹.

A more exacting theory on this subject is obtained from Lazan's work: "In the opinion of Hempel and Tillmanns, creep under dynamic tension is approximately the same as at a static tension equal to the upper limit of the dynamic test for the materials studies. Furthermore, they observed that frequency does not seriously affect dynamic creep in the tests undertaken"². (Hempel and Tillmanns conducted tests on carbon, molybdenum, and chromium-nickel steels).³

- - - - -
1. Lin, DESIGN OF PRESTRESSED CONCRETE STRUCTURES, p. 88
 2. Lazan, DYNAMIC CREEP AND RUPTURE PROPERTIES OF TEMPERATURE-RESISTANT MATERIALS UNDER TENSILE FATIGUE STRESS, Proceedings ASTM, 49:759
 3. Hempel and Tillmanns, VERHALTEN DES STAHLER BIE HOHEREN TEMPERATUREN UNTER WECHSELNDE ZUGBEANSPRUCHUNG, Mitteilungen, 18:163

Probably the most concise study of this problem to date is that conducted by R. Zinsser¹. He studied the creep behavior of both patent drawn and heat treated wires under repeated loading in tension. Two curves from his paper are presented here. (See Figures 3 and 4).

Although this is a very good study of wire, it does not give a complete understanding of what happens in the case of the strand under this same type of loading. This latter study is attempted in this paper.

1. Zinsser. THE CREEP OF STEEL WIRE UNDER PULSATING TENSILE STRESSES, Stahl und Eisen, Jan. '54, p. 145

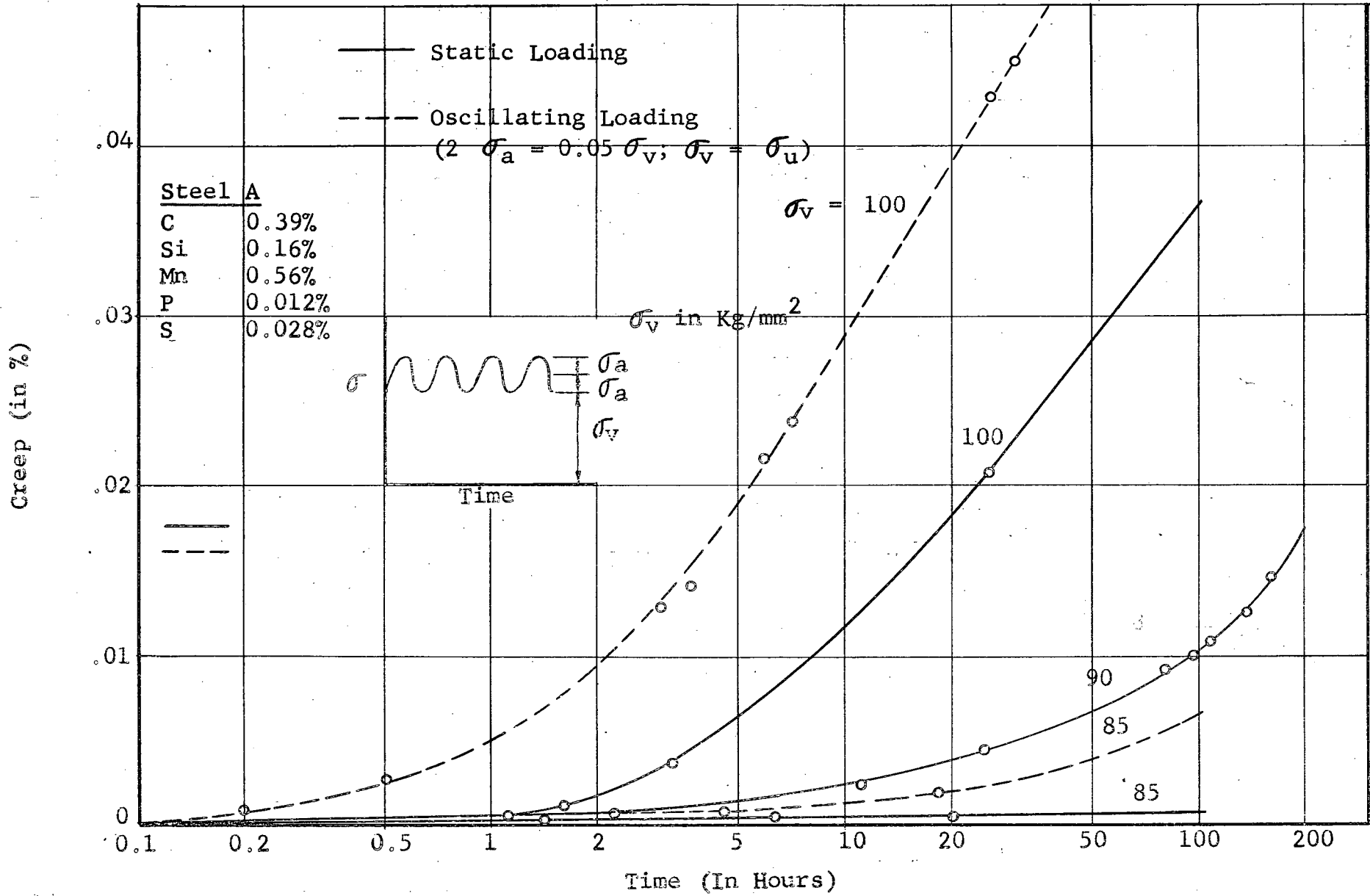

FIGURE 3 - CREEP CURVES FOR STATIC AND OSCILLATING LOADING UNDER VARIOUS PRETENSIONS FOR STEEL A IN THE HEAT-TREATED CONDITION (BY RUDOLPH ZINSSER)

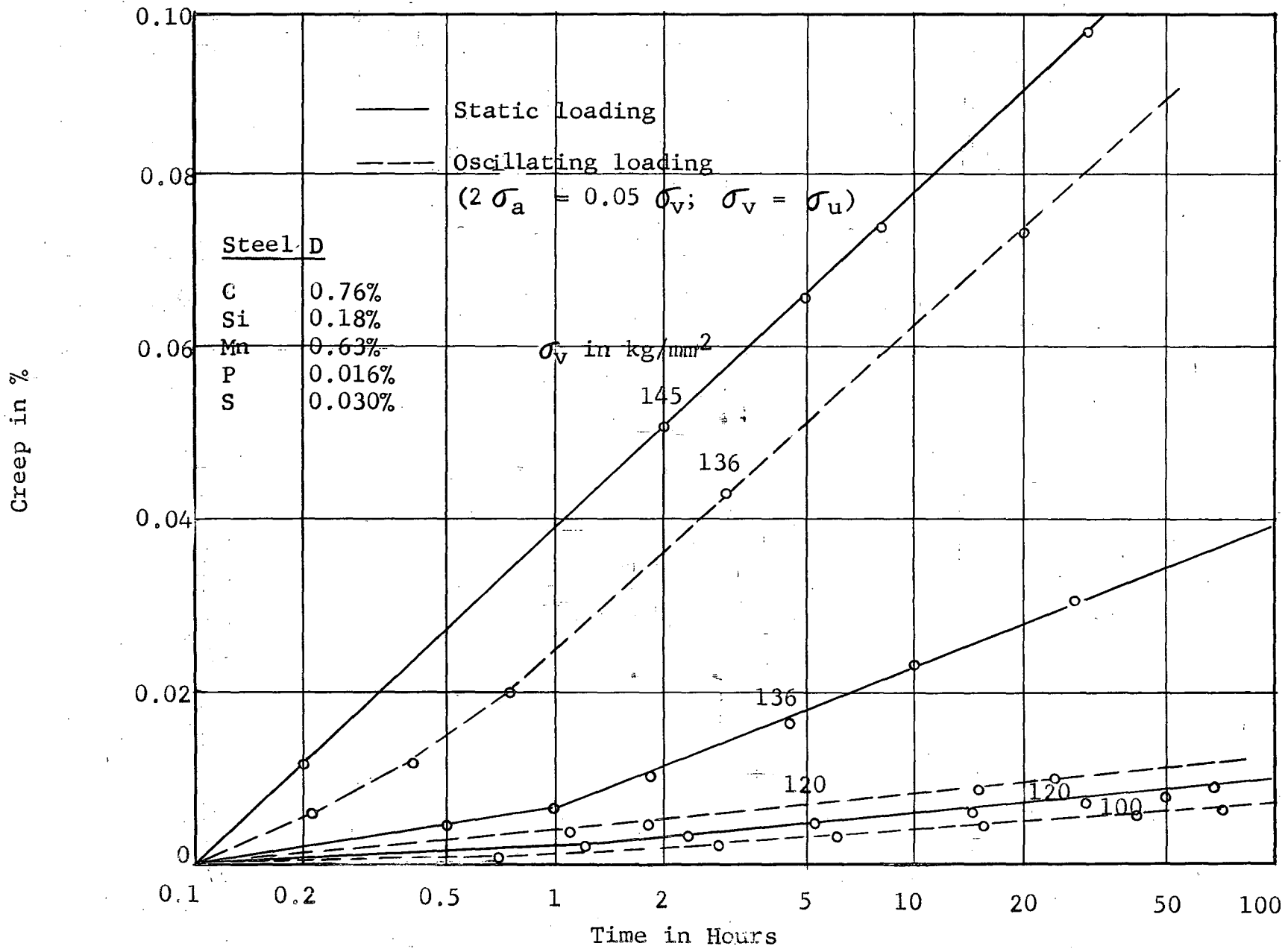

FIGURE 4 - CREEP CURVES FOR STATIC AND OSCILLATING LOADING (STEEL D HEAT TREATED) BY ZINSSER

CHAPTER III

EXPERIMENTAL INVESTIGATION

It has been shown in the preceding chapter that there is a definite need for information on the fatigue resistance of high strength steel prestressing strands, and for information on the creep characteristics under repetitive loads for these same strands. Therefore, a test program was initiated in the fall of 1957 to obtain a more definite picture of these two phenomena.

Preparation of Specimens

Rather than merely testing simple lengths of strand in a testing machine, it was decided to prepare a slightly more complicated specimen in order to achieve better results. A specimen similar to that shown in Figures 5 and 6 was chosen. In the following section, reference is made to numbered parts of these figures.

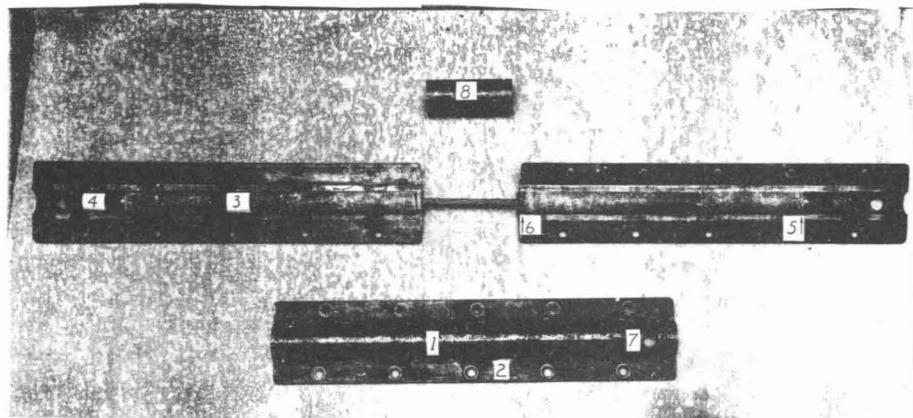

Figure 5 Component Parts of a Typical Specimen

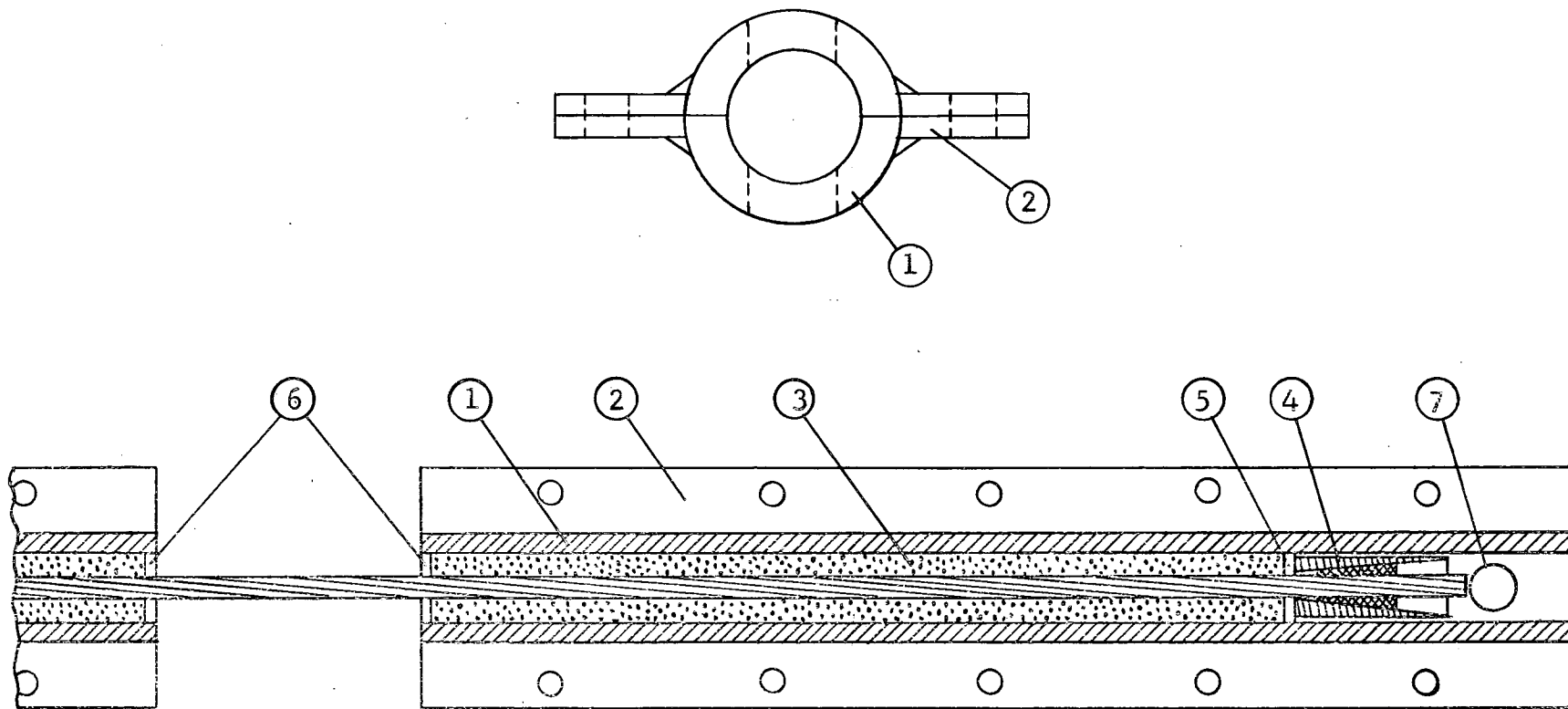

FIGURE 6 - A TYPICAL SPECIMEN

Component Parts

Two-inch double extra-strong pipe sections (1) were chosen to encase the strand. These were split in half longitudinally and welded to flange plates (2) for easy removal and replacement of strand specimens. When in use, the pipe halves were bolted together with 10 half-inch bolts.

A stiff Type III Portland cement grout (3) was forced into the pipe sections encompassing the strand. The purpose of this grout was to allow a gradual buildup of load in the strand due to bond forces in order to simulate the action in a beam, and also to eliminate the possibility of a strand failure due to a stress concentration at the Strandvises (4).

These grips (No.5976 and No.5977 Reliable Steelcase Strandvises, Reliable Electric Company, Chicago, Illinois) were placed on the strand to enable the strand to develop its full strength, even if a bond failure should occur. In order to get more efficient action from the Strandwise, a steel bearing washer (5) was used. This washer also acted in conjunction with the wooden washers at the inner ends of the pipe sections (6) as a centering device for the strand while the grout was curing.

A 6" space was left between the two pipe sections for later instrumentation during the test. During the preparation of the specimens, this space was maintained

through use of a slotted spacer section (8). Holes for 1" diameter pins (7) were provided in each end of the specimen for later attachment in the testing rig.

Procedure

The first step in the preparation of a specimen was the tensioning of the strand. All strands were pretensioned to approximately 140 000 psi in a special tensioning apparatus (see Figure 7), the centering and bearing washers already being on the strand. The elongation for the strand at this stress was obtained, using a Modulus of Elasticity of 27 million psi, and the stress level for the tensioning operation was determined by actual measurement of elongation with a scale using a mark on the strand. The purpose of this tension was to give a more perfect alignment of the strand within the pipe casings, and to place the individual wires of the strand in a position similar to that which they would occupy during the test so that there would be as little grating action of the grout as possible in areas of broken bond.

The pipe sections were then bolted around the strand to provide a formwork for the grout. For each specimen, the grout proportions by weight were: 1 part Type III Portland Cement, 1.3 parts sand, and 1.54 parts water.

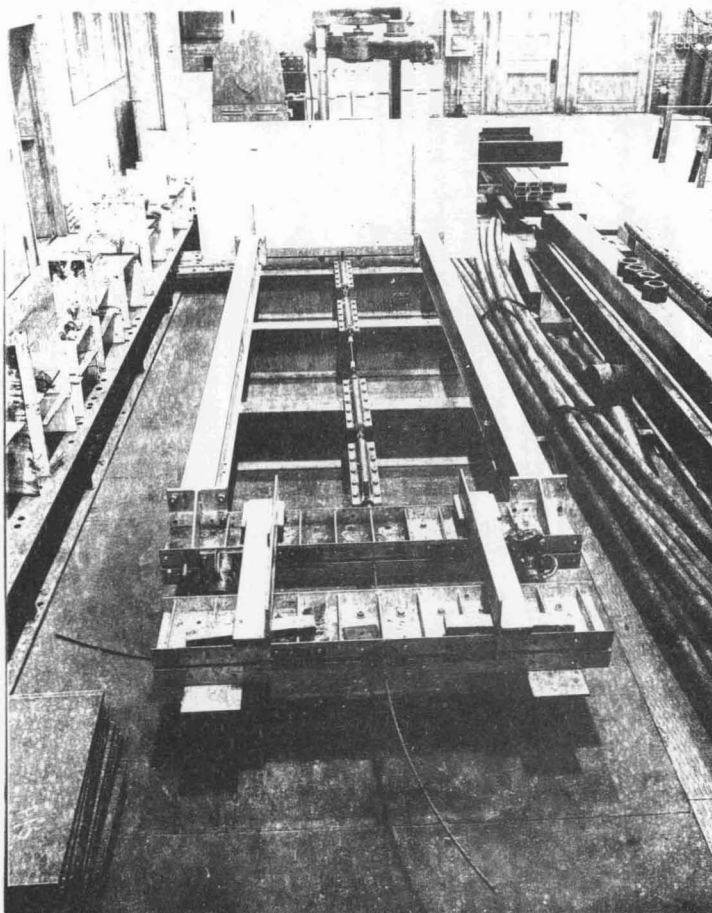

Figure 7 Tensioning Apparatus

After the pipe sections were in place and the proportions were mixed, the grout was forced into the pipe casing encompassing the strand by use of a special tamping rod (see Figure 8). The centering washers were then positioned; the slotted spacer section was moved into place; and the specimens were allowed to cure.

After about five days the prestress was released on the tensioning apparatus, but was actually maintained in the gap of the individual specimens through the use of the slotted spacer section (part 8, Figure 6). The Strandvises (part 4) were then positioned inside the ends of the specimen and the excess strand burned off through the pin holes (part 7) provided in the specimen ends. The specimens were allowed to cure for a minimum of two additional days before testing.

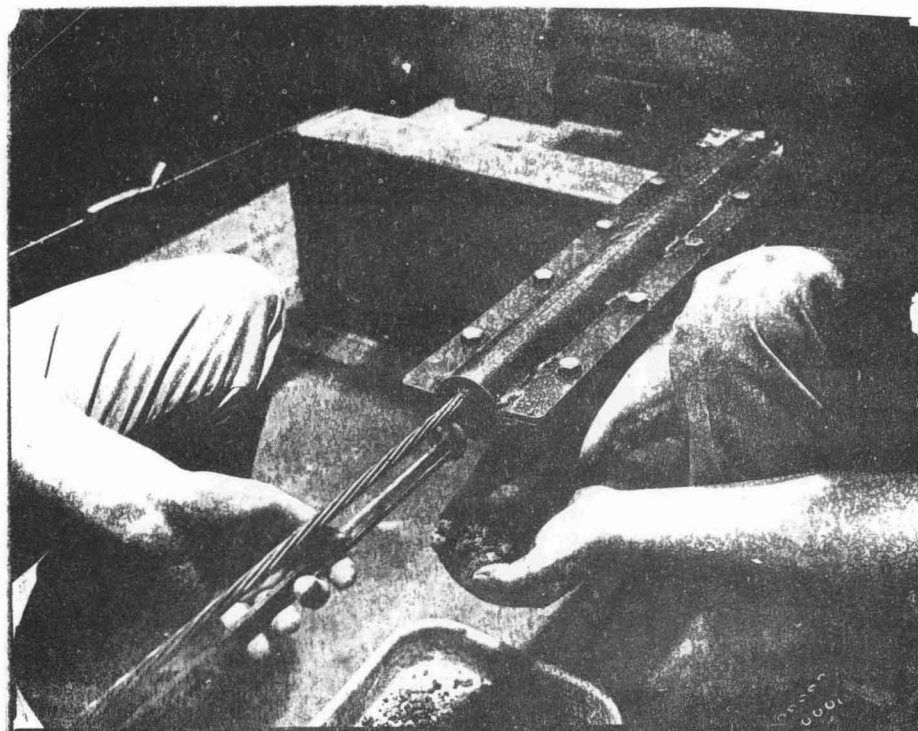

Figure 8 The Grouting Operation

Testing Equipment

The testing equipment used in this investigation may be divided into three separate classifications: the structural framework for transmitting loads and giving stability to the specimen; the actual load applying agent; and the gaging and recording equipment.

Structural Framework

The first, the structural framework (see Figure 9), is of a rather simple nature. A welded steel bracing frame (a) is bolted to the dynamic test bed of the laboratory with four 3-1/2" bolts. Hinged to the upper portion of this frame is an 8WF48 loading beam (b). At a distance of 2' 0" along this beam from the hinge, the specimen is attached through the use of a hinged bearing device (c). At a distance of 4' 1-1/8" from the hinge, the load is applied, giving an approximate ratio of load on specimen to load applied of 2.05.

Also bolted to the dynamic test bed and directly under the point of load application, is a 2' 6" high 12WF85 stub column (d). The top of this column is used to support the loading jack. Bolted between this column and the welded bracing frame is an 8WF31 base beam (e). The specimen is attached to this beam with a hinged bearing similar to that on the loading beam directly above. Both the loading beam and the base beam were stiffened at points of concentrated loading with four 1/2" thick welded stiffeners.

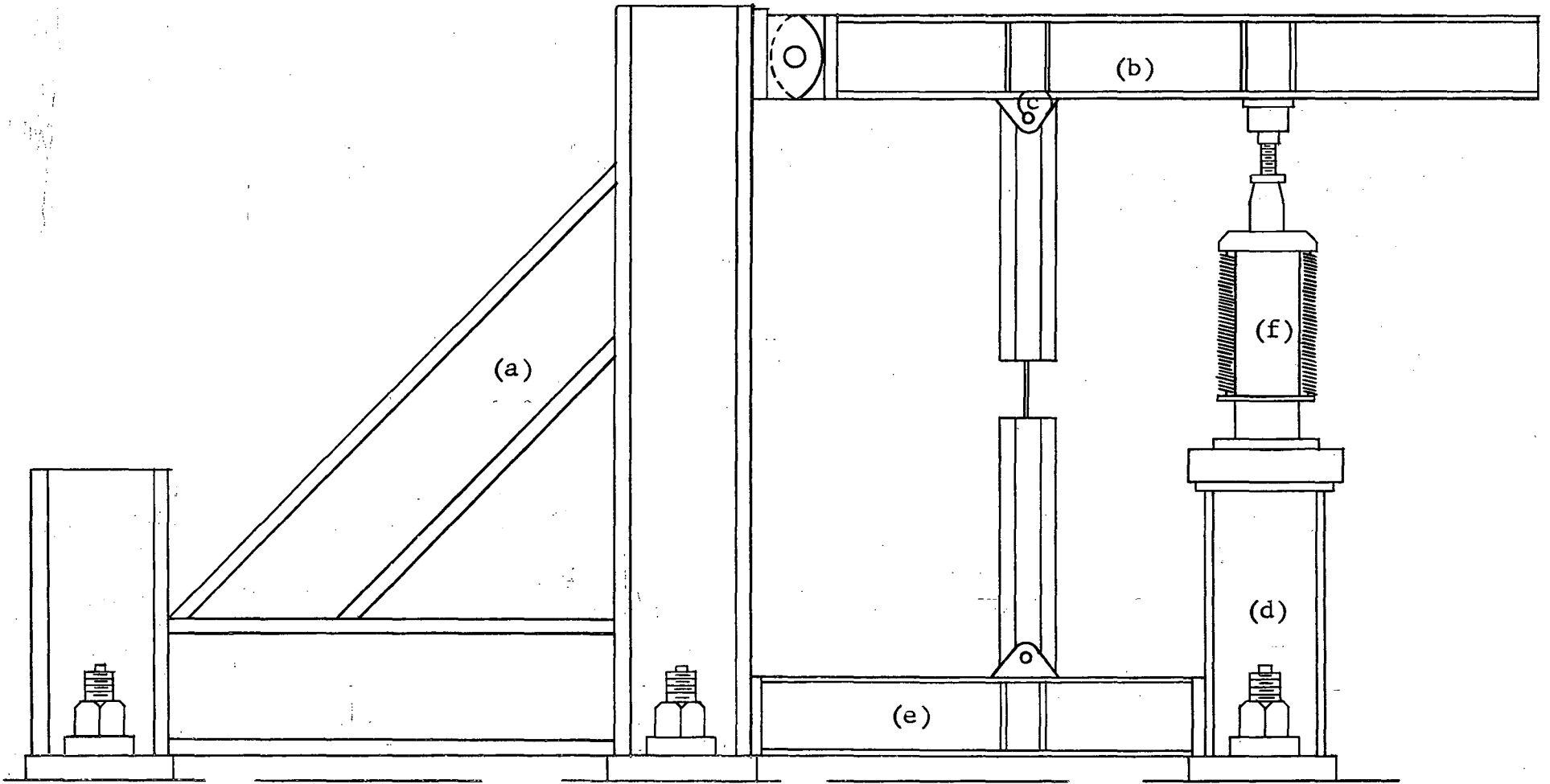

FIGURE 9 - STRUCTURAL FRAMEWORK

Load Applying Agent

The actual load applying agent consisted of the combination of an Amsler Pulsator type PA 131 connected to a 10-ton capacity Amsler Hydraulic Jack. Both of these are manufactured by Alfred J. Amsler & Company, Schaffhausen, Switzerland. The position of the jack (f) is shown in Figure 9. All the dynamic tests were run at a loading frequency of 500 cycles per minute.

Gaging and Recording Equipment

For determining the loads placed on the specimen the Amsler pulsator maximum and minimum load dials were used. In addition to these, three pair of SR-4 electric strain gages were placed on the top and bottom flanges of the loading beam midway between the loading jack and the specimen. These gave an accurate check on the Amsler readings. All dials and gages were calibrated and checked periodically with a bar dynamometer which was placed in the position normally occupied by the specimen.

To obtain the creep data, a special type of gaging was used (see Figure 10). Two aluminum block clamps were bolted around the strand with 2-3/8" bolts in each block. These blocks were set with a 4-1/8" inside gage length within the 6" gap between pipe sections. For better gripping action, these blocks were lined with carborundum paper.

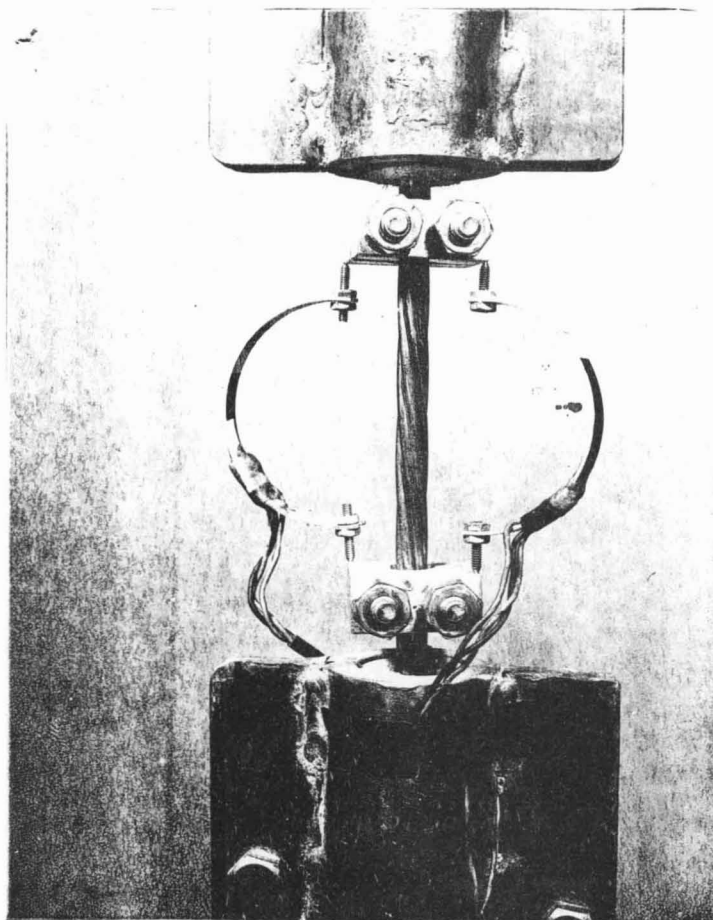

Figure 10 Clip Gages for Measuring Creep

Special aluminum clip gages similar to those designed and used by the University of Illinois, were then spring fitted between the blocks. The aluminum clips were equipped with SR-4 electric strain gages which indicated the bending strains in the clip which accompanied displacements of the blocks, thus providing an efficient method of measuring the creep strains.

Each clip gage, as well as each loading strain gage, was wired into a Universal Amplified Model BL-520, manufactured by Brush Electronics Company, Cleveland, Ohio. (see Figure 11). The outputs from these amplifiers were fed into a 6 Channel Oscillograph Model BL-256, also manufactured by the Brush Electronics Company. This, then, allowed continuous recording of both load and creep strains in a permanent recorded form.

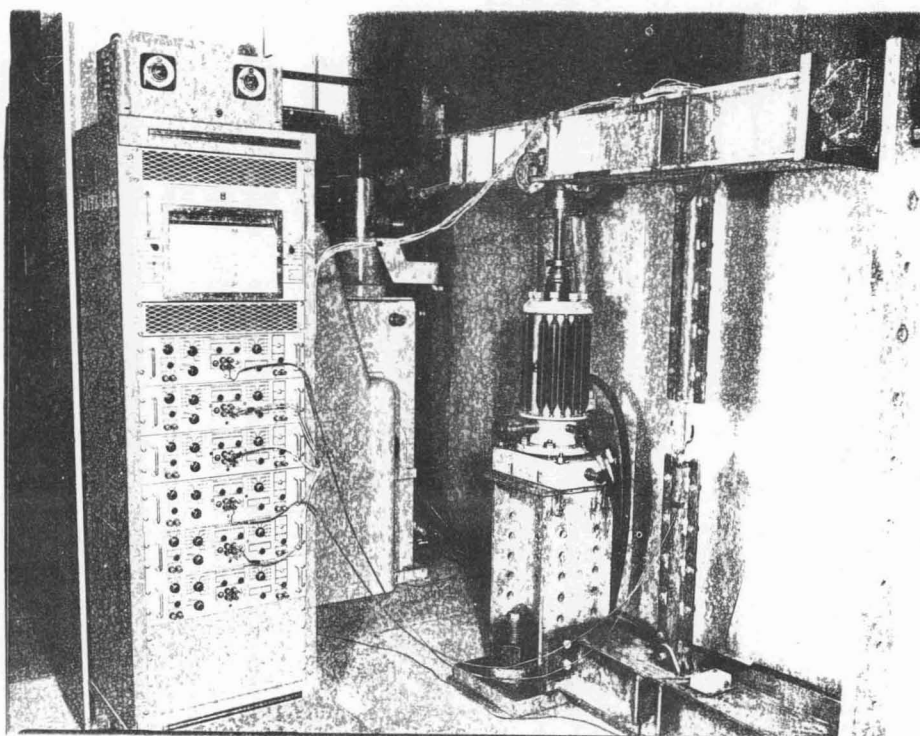

Figure 11 A Test in Progress

Testing Procedure

Using this equipment, a testing procedure similar to that which is described below, was followed. After first allowing the Amsler and Brush equipment to warm up for at least twenty minutes, the test was started.

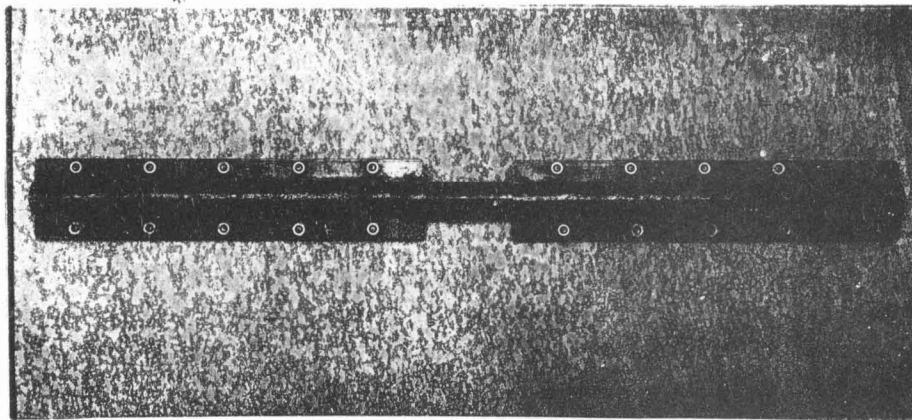

Figure 12 Specimen Just Prior to Testing

Static load was slowly applied to the specimen with the Amsler equipment until a relaxation of pressure on the slotted spacers of the specimen was noticed, thus indicating that the load applied had reached the level of the effective prestress remaining in the specimen after release from the tensioning apparatus. This load was noted for the later specimens.

Additional static load was then applied until the level of the intended mean load of the proposed test was reached, at which point the load was held constant. The average time used for increasing the load to this mean load of the test was approximately four minutes.

The purpose of holding the load steady at this point was for placement of the block clamps for the measurement of creep. The blocks, lined with carborundum paper, are a friction type grip, and it was found that unless these blocks were positioned at a load near the testing loads, the elastic

shrinkage in the cross section of the specimen caused by the loading was enough to counteract the original tightening of the blocks and they would slip. The average time used for this operation was approximately ten minutes.

Over a time interval of approximately two minutes, the load was lowered from this mean load position to one thousand pounds, where the Brush amplifiers were balanced and all gages zeroed. A static test was then run, holding the load at each thousand-pound increment for about twenty seconds to calibrate the two clip gages later used for creep determination. This test was run from one thousand pounds to the mean cycling load in an average time of fourteen minutes.

Finally, the dynamic load was gradually superimposed over a period of approximately 1-1/2 minutes until the desired amplitude was obtained. This point was set as zero time for the dynamic creep curves.

A continuous record of the creep strains and accompanying dynamic loads was obtained for the first six minutes of the dynamic test, and thereafter twenty-second samplings were obtained every twenty minutes until the end of the test.

Test Results and Observations

General

Using the testing equipment and procedures outlined earlier in the chapter, a total of 45 specimens were tested.

The data obtained from these tests are shown in Tables II and III. The first 27 of these tests were run with slight variations of procedure to determine the best possible way of utilizing the available equipment to obtain a test most nearly simulating the actual beam situation while still giving testing facility.

The first 15 specimens were fabricated with a very low initial prestress (approximately 70 000 psi), but this was later increased to approximately 138 000 psi for the following reason. The lay of the wires in a strand changes with load and thus, if low prestress were used, impressions would be formed in the grout which would not conform to the normal lay of the strand wires at the testing loads, thus creating additional bond stresses and abraision.

Various gaging methods for obtaining creep measurements were attempted in these early specimens as well. Specimens No. 1-3 inclusive, and 24-27 inclusive, were fitted with various attachments in an attempt to measure the creep strains with a Huggenberger Tensometer. A-12 electric strain gages were fixed directly to individual wires of the strand of specimen 4, but results seemed poor. Three types of block clamps were tested: Specimens No. 1-15 inclusive, being equipped with lead-lined steel clamps; Specimens No. 16-23 inclusive, being equipped with carborundum-lined steel clamps, and all later specimens being fitted with carborundum-lined aluminum clamps which proved to be the best.

Table II Recorded Data for Strand Fatigue and Creep Tests

| Specimen Number | Strand Size | Date Tensioned | Date Grouted | Date Released | Date Test Started | Loading % Static Ultimate | | Total Cycles x 10 ³ | Failure or Non-Failure | Type and Position of Failure | Maximum Creep Value | Creep Time - hr. | Slip (inches) | Prestress in Gap | |
|-----------------|-------------|----------------|--------------|---------------|-------------------|---------------------------|------|--------------------------------|------------------------|------------------------------|---------------------|------------------|---------------|------------------|------|
| | | | | | | Min. | Max. | | | | | | | | |
| | | 1957 | 1957 | 1957 | 1957 | | | | | | | | | | kips |
| 1 | 7/16 | 11/18 | 11/18 | 11/25 | 12/7 | 51.9 | 66.7 | 202.8 | F | 2 ow 1 5/8" gt 1 5/8" gb | | | | | |
| 2 | 7/16 | 11/18 | 11/18 | 11/25 | 12/9 | 51.9 | 66.7 | 172.2 | F | 1 ow - g | | | 0.750 | | |
| 3 | 3/8 | 11/18 | 11/18 | 11/25 | 12/9 | 50.0 | 66.0 | 66.6 | F | 1 ow - g | -- | -- | 1.000 | -- | |
| 4 | 3/8 | 11/18 | 11/18 | 11/25 | 2/7* | 50.0 | 65.0 | 75.4 | F | 1 ow 1/2" gt | -- | -- | 0.625 | -- | |
| | | 1958 | 1958 | 1958 | 1958 | | | | | | | | | | |
| 5 | 3/8 | 2/12 | 2/12 | 2/19 | 2/26 | -- | -- | - | F | Slip | -- | -- | 1.625 | -- | |
| 6 | 7/16 | 2/12 | 2/12 | 2/19 | 2/27 | -- | -- | - | F | Slip | -- | -- | 3.000 | -- | |
| 7 | 3/8 | 2/12 | 2/12 | 2/19 | 3/3 | -- | -- | - | F | Slip | -- | -- | 2.000 | -- | |
| 8 | 7/16 | 2/12 | 2/12 | 2/19 | 3/5 | -- | -- | - | F | Slip | -- | -- | 2.000 | -- | |
| 9 | 7/16 | 2/28 | 2/28 | 3/7 | 3/10 | 50.0 | 60.0 | 229.4 | F | 1 ow 1 1/4" gt | -- | -- | - | -- | |
| 10 | 7/16 | 2/28 | 2/28 | 3/7 | 3/11 | 50.0 | 60.0 | 331.2 | NF | Equipment | -- | -- | - | -- | |
| 11 | 3/8 | 3/6 | 3/7 | 3/12 | 3/17 | 50.0 | 60.0 | 769.4 | F | 1 ow 1/4" it | -- | -- | - | -- | |
| 12 | 3/8 | 3/6 | 3/7 | 3/12 | 3/19 | 50.0 | 60.0 | 1145.5 | F | 1 ow 3" it | 1691 | 28.0 | - | -- | |

Table II, continued

| Specimen Number | Strand Size | Date Tensioned | Date Grouted | Date Released | Date Test Started | % Loading Static Ultimate | | Total Cycles x 10 ³ | Failure or Non-Failure | Type and Position of Failure | Maximum Creep Value | Creep Time - hr. | Slip (inches) | Prestress in Gap |
|-----------------|-------------|----------------|--------------|---------------|-------------------|---------------------------|------|--------------------------------|------------------------|------------------------------|---------------------|------------------|---------------|------------------|
| | | | | | | Min. | Max. | | | | | | | |
| 13 | 3/8 | 3/6 | 3/7 | 3/12 | 3/24 | 50.0 | 60.0 | 312.6 | F | 1 ow - g | -- | -- | - | - |
| 14 | 7/16 | 3/14 | 3/18 | 3/25 | 4/10 | 50.0 | 60.0 | 1480.0 | NF | --- | 1180 | 94.0 | - | - |
| 15 | 7/16 | 3/14 | 3/18 | 3/25 | 4/16 | 50.0 | 60.0 | 1466.8 | NF | --- | -- | -- | - | - |
| 16 | 7/16 | 3/25 | 3/26 | 4/9 | 4/21 | 50.0 | 60.0 | 337.2 | NF | Equipment | 554 | 7.0 | - | - |
| 17 | 7/16 | 3/25 | 3/26 | 4/9 | 4/28 | 50.0 | 60.0 | 397.7 | NF | Equipment | -- | -- | - | - |
| 18 | 3/8 | 4/16 | 4/18 | 4/24 | 4/30 | 60.0 | 70.0 | 1420.5 | F | 1 ow 3/4" ib | -- | -- | - | - |
| 19 | 3/8 | 4/16 | 4/18 | 4/24 | 5/6 | 60.0 | 70.0 | 360.2 | F | 1 ow 1/4" gb | 2751 | 11.2 | - | - |
| 20 | 3/8 | 4/29 | 4/30 | 5/5 | 5/12 | 60.0 | 70.0 | 1395.0 | NF | --- | 1784 | 9.7 | - | - |
| 21 | 3/8 | 4/29 | 4/30 | 5/5 | 5/23 | 60.0 | 70.0 | 124.7 | F | 1 ow 1" ib | -- | -- | - | - |
| 22 | 3/8 | 5/7 | 5/7 | 5/12 | 6/2 | 60.0 | 70.0 | 1390.0 | NF | --- | 1610 | 43.1 | - | - |
| 23 | 3/8 | 5/7 | 5/7 | 5/12 | 6/4 | 80.0 | 85.0 | 1365.0 | NF | --- | 1197 | 42.5 | - | - |
| 24 | 7/16 | 6/3 | 6/5 | 6/13 | 7/10 | 50.0 | 65.0 | 260.0 | NF | --- | -- | -- | - | - |
| 25 | 7/16 | 6/3 | 6/5 | 6/13 | 7/15 | 50.0 | 65.0 | 464.0 | F | 2 ow, gtc | -- | -- | - | - |

Table II, continued

| Specimen Number | Strand Size | Date Tensioned | Date Grouted | Date Released | Date Test Started | Loading % Static Ultimate | | Total Cycles x 10 ³ | Failure or Non-Failure | Type and Position of Failure | Maximum Creep Value | Creep Time - hr. | Slip (inches) | Prestress in Gap |
|-----------------|-------------|----------------|--------------|---------------|-------------------|---------------------------|------|--------------------------------|------------------------|------------------------------|---------------------|------------------|---------------|------------------|
| | | | | | | Min. | Max. | | | | | | | |
| 26 | 7/16 | 6/3 | 6/5 | 6/13 | 7/17 | 50.0 | 65.0 | 2117.2 | NF | -- | -- | -- | - | -- |
| 27 | 7/16 | 6/3 | 6/5 | 6/13 | 7/20 | 50.0 | 65.0 | 1469.7 | NF | -- | -- | -- | - | -- |
| 28 | 7/16 | 9/12 | 9/16 | 9/19 | 9/22 | 70.0 | 79.0 | 1564.5 | NF | -- | 1320 | 48.9 | - | -- |
| 29 | 7/16 | 9/12 | 9/16 | 9/19 | 9/26 | 70.0 | 79.0 | 864.0 | F | 1 ow, gbc | 1649 | 27.3 | 1.500 | -- |
| 30 | 7/16 | 9/12 | 9/16 | 9/19 | 10/2 | 70.0 | 79.0 | 2962.8 | NF | --- | 1651 | 95.0 | 1.500 | -- |
| 31 | 7/16 | 9/12 | 9/16 | 9/19 | 10/8 | 54.5 | 68.0 | 1326.1 | F | 1 ow 1/2" gb | 736 | 42.1 | 1.344 | -- |
| 32 | 7/16 | 10/6 | 10/7 | 10/13 | 10/13 | 54.5 | 68.0 | 422.0 | F | 1 ow 1 1/4" it | -- | -- | 0.500 | -- |
| 33 | 7/16 | 10/6 | 10/7 | 10/13 | 10/14 | 54.5 | 68.0 | 2967.6 | F | 1 ow 1 1/2" it | 1649 | 83.9 | 0.625 | 14.0 |
| 34 | 7/16 | 10/6 | 10/7 | 10/13 | 10/21 | 52.9 | 68.9 | 304.7 | F | 1 ow 1 1/2" ib | -- | -- | 1.063 | 12.0 |
| 35 | 7/16 | 10/6 | 10/7 | 10/13 | 10/23 | 52.9 | 68.9 | 1041.1 | F | 1 ow 3/8" ib | 410 | 15.2 | 0.500 | 10.5 |
| 36 | 7/16 | 10/14 | 10/15 | 10/20 | 10/27 | 54.5 | 71.1 | 2101.2 | F | 1 ow 1 1/2" it | 2255 | 67.3 | 1.906 | 9.5 |
| 37 | 7/16 | 10/14 | 10/15 | 10/20 | 10/31 | 54.5 | 73.0 | 151.5 | F | 1 ow 2 1/8" gb | 452 | 4.8 | 1.281 | 7.5 |

Table II, concluded

| Specimen Number | Strand Size | Date Tensioned | Date Grouted | Date Released | Date Test Started | Loading % Static Ultimate | | Total Cycles x 10 ³ | Failure or Non-Failure | Type and Position of Failure | Maximum Creep Value | Creep Time - hr. | Slip (inches) | Prestress in Gap |
|-----------------|-------------|----------------|--------------|---------------|-------------------|---------------------------|------|--------------------------------|------------------------|------------------------------|---------------------|------------------|---------------|------------------|
| | | | | | | Min. | Max. | | | | | | | |
| 38 | 7/16 | 10/23 | 10/23 | 10/29 | 11/3 | 54.5 | 71.1 | 373.2 | F | cw 2 1/4" gt | 1337 | 11.9 | 0.750 | 12.4 |
| 39 | 7/16 | 10/23 | 10/23 | 10/29 | 11/4 | 65.2 | 75.0 | 4107.1 | NF | --- | 1159 | 16.9 | 0.813 | 13.1 |
| 40 | 7/16 | 11/3 | 11/3 | 11/7 | 11/11 | 65.2 | 80.0 | 356.4 | F | 1 ow b | -- | -- | - | 10.1 |
| 41 | 7/16 | 11/3 | 11/3 | 11/7 | 11/13 | 65.2 | 75.9 | 3733.5 | NF | --- | 1439 | 119.2 | 0.969 | 10.7 |
| 42 | 7/16 | 11/10 | 11/10 | 11/14 | 11/18 | 65.2 | 78.1 | 980.2 | F | 1 ow 1 1/2" gb | 812 | 30.5 | 0.844 | 11.2 |
| 43 | 7/16 | 11/10 | 11/10 | 11/14 | 11/20 | 65.2 | 79.0 | 294.2 | F | 1 ow, gbc | 1311 | 9.0 | 0.875 | 7.0 |
| 44 | 7/16 | 11/17 | 11/17 | 11/21 | 11/24 | 54.5 | 77.0 | 84.4 | F | 1 ow 1/4" gb | 1767 | 2.5 | 0.656 | 12.4 |
| 45 | 7/16 | 11/17 | 11/17 | 11/21 | 11/25 | 65.2 | 77.0 | 368.4 | F | 1 ow 1 3/4" gt | 1342 | 11.5 | 0.875 | 6.5 |

Legend: ow = outside wire

tc = at top clamp

cw = center wire

bc = at bottom clamp

gt = in gap, failure measured from top pipe

gb = in gap, failure measured from bottom pipe

TABLE IIIRemarks Pertaining to Table II

| <u>Specimen No.</u> | <u>Remarks</u> |
|-------------------------|--|
| 1 | Loading inaccurate; creep measurements by Huggenberger unsuccessful. |
| 2 | Recorded slip occurred during static test. |
| 4 | 3 A-12 gages on alternate wires; creep measurements unsuccessful. |
| 5 - 8 | Amsler jack unstable due to large slip. |
| 9 | Block clamps slipped at first application of dynamic load; |
| 10 | Block clamps slipped at first application of dynamic load; Trouble with pulsator |
| 11 | Block clamps slipped at first application of dynamic load; signs of abrasion around failure. |
| 12 | Rust present around failure. |
| 13 | Overload on specimen |
| 14 | 250 cpm for comparison; Loading uncertain due to calibration difficulties. |
| 15 | Block clamps slipped during test. |
| 16, 17 | Trouble with pulsator. |
| 18 | Clip gages (wiring difficulties) |
| 19 | Overload for 1-1/2 hours |
| 24 | Creep Measurements by Huggenberger unsuccessful; Trouble with pulsator. |

TABLE III (Continued)

| <u>Specimen No.</u> | <u>Remarks</u> |
|-------------------------|--|
| 25 | Creep Measurements by Huggenberger unsuccessful; Top clamp possibly too tight |
| 26 | Creep Measurements by Huggenberger unsuccessful. |
| 27 | Creep Measurements by Huggenberger unsuccessful; Test halted 7/21, continued 9/15. |
| 29 | Bottom clamp possibly too tight. |
| 32, 33 | Rust present around failure. |
| 34 | Large stone bearing on strand at failure point; Approximately 17° block rotation noticed. |
| 36 | Rust present around failure |
| 39, 41 | Static failure at 111% of catalog ultimate load. |
| 43 | Clamp possibly too tight. |

Two types of specimen holders were tried, with the one described earlier in the chapter being chosen. After a close examination of Table II, one may see the effectiveness of this type of specimen holder. Not one strand failed at or near the Strandvises; all failures were confined to the center 12 inches of the specimen. Within this length failures were not concentrated at any one point, but were distributed fairly evenly throughout the zone. Two specimens did fail at the block clamps for the creep gages, indicating a possible stress concentration due to the sudden restraint of individual movement of the wires caused by the bolts being too tight. However, in general, these blocks seemed to cause no ill effects.

Fatigue

Tests of Specimens No. 28-45 inclusive, were all conducted with the standard procedure outlined, and were used in the determination of two S-N curves. (See Figures 13 and 14).

Figure 13 shows an S-N curve for a minimum load of 54.5% of static ultimate strength (catalog value 27 000 lb. for 7/16" strand). Relatively small scatter was observed and the curve, as shown, appears to be quite smooth. The maximum deviation of any point from the curve is 4.87%. A comparison was made between this curve and one obtained earlier by Mr. Nuwaysir at a minimum of 55.3% (see Figure 15), and a fairly close coordination was found.

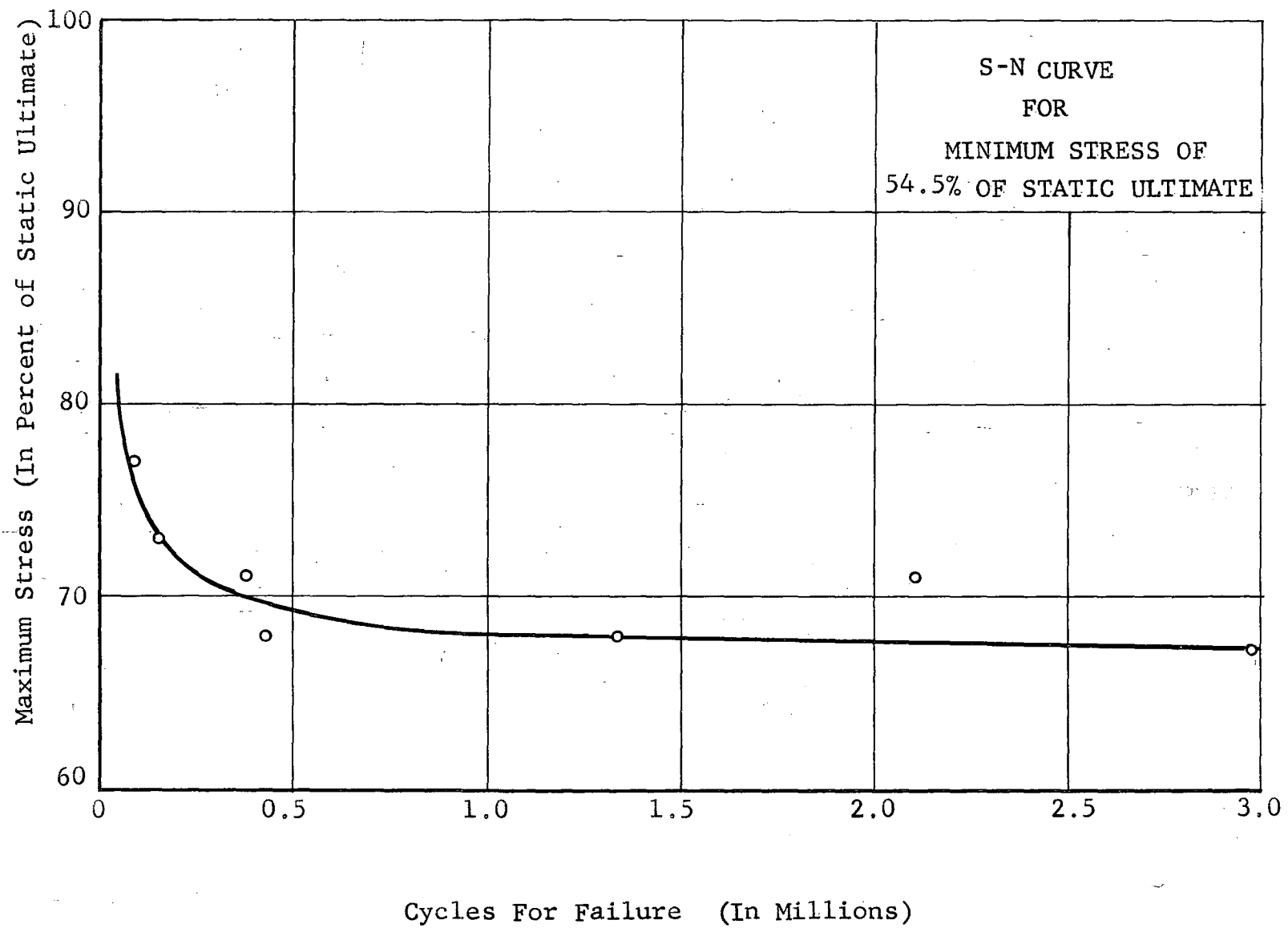

FIGURE 13

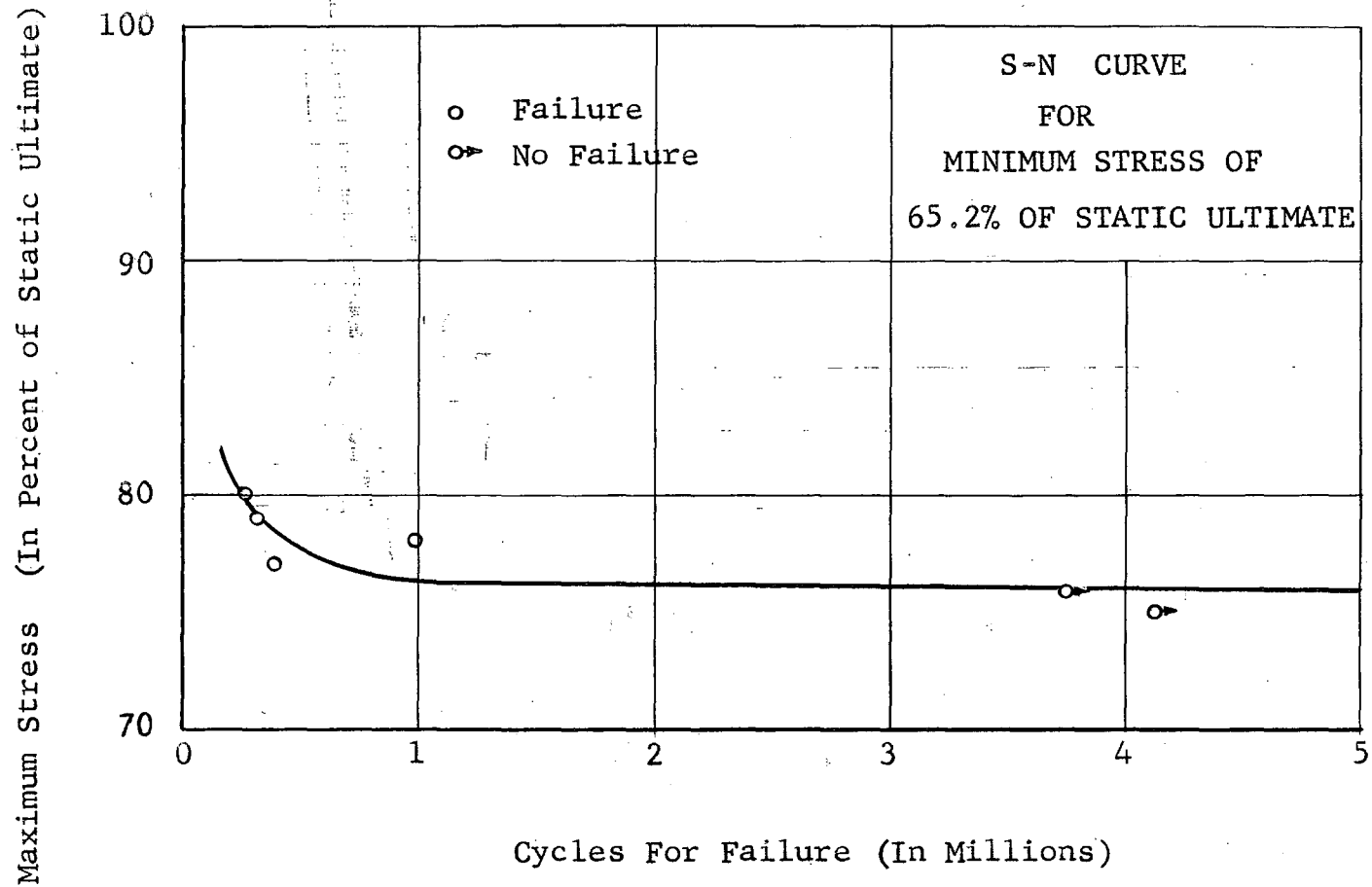

FIGURE 14

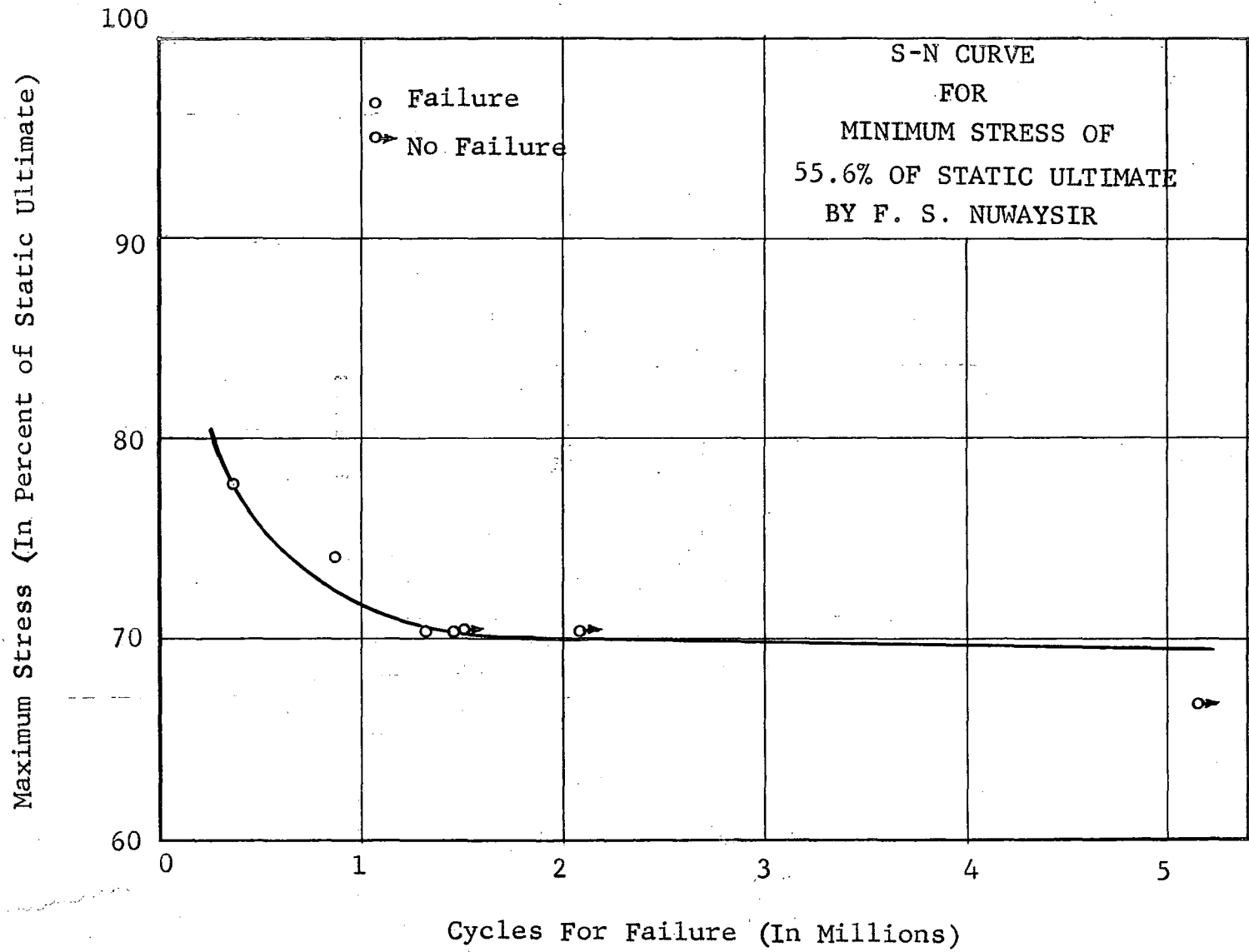

FIGURE 15

Figure 14, an S-N curve obtained for a minimum load of 65.2% of static ultimate strength, also gives a smooth curve with little scatter. However, two of the points do not have set positions due to the fact that no failure was obtained. These allow a certain amount of freedom in the choice of a final slope of the S-N curve, and additional tests are required.

All three of these curves, however, do point out the validity of choosing one million cycles as the point for which a failure envelope, as mentioned earlier, should be determined. The shape of all three curves is such that the ordinate to each curve at one million cycles appears to be very close to the endurance limit. This fact is the basis for the use of the envelope shown in Figure 1.

Figure 16 shows the verification of the assumed failure envelope for one million cycles with the specimens tested in this program. The letter next to each point indicates whether or not the specimen failed, and the number indicates the number of cycles, in millions, e.g., 2F 0.9, 1.0 means two specimens failed under the loading indicated by the position of the point, one at 0.9 million cycles and one at 1.0 million cycles. Each point is plotted so that the ordinate and abscissa represent the maximum and minimum applied stress, respectively. Ten specimens were tested at stress ranges plotted above the envelope, indicating a failure at less than one million cycles. All but two of these

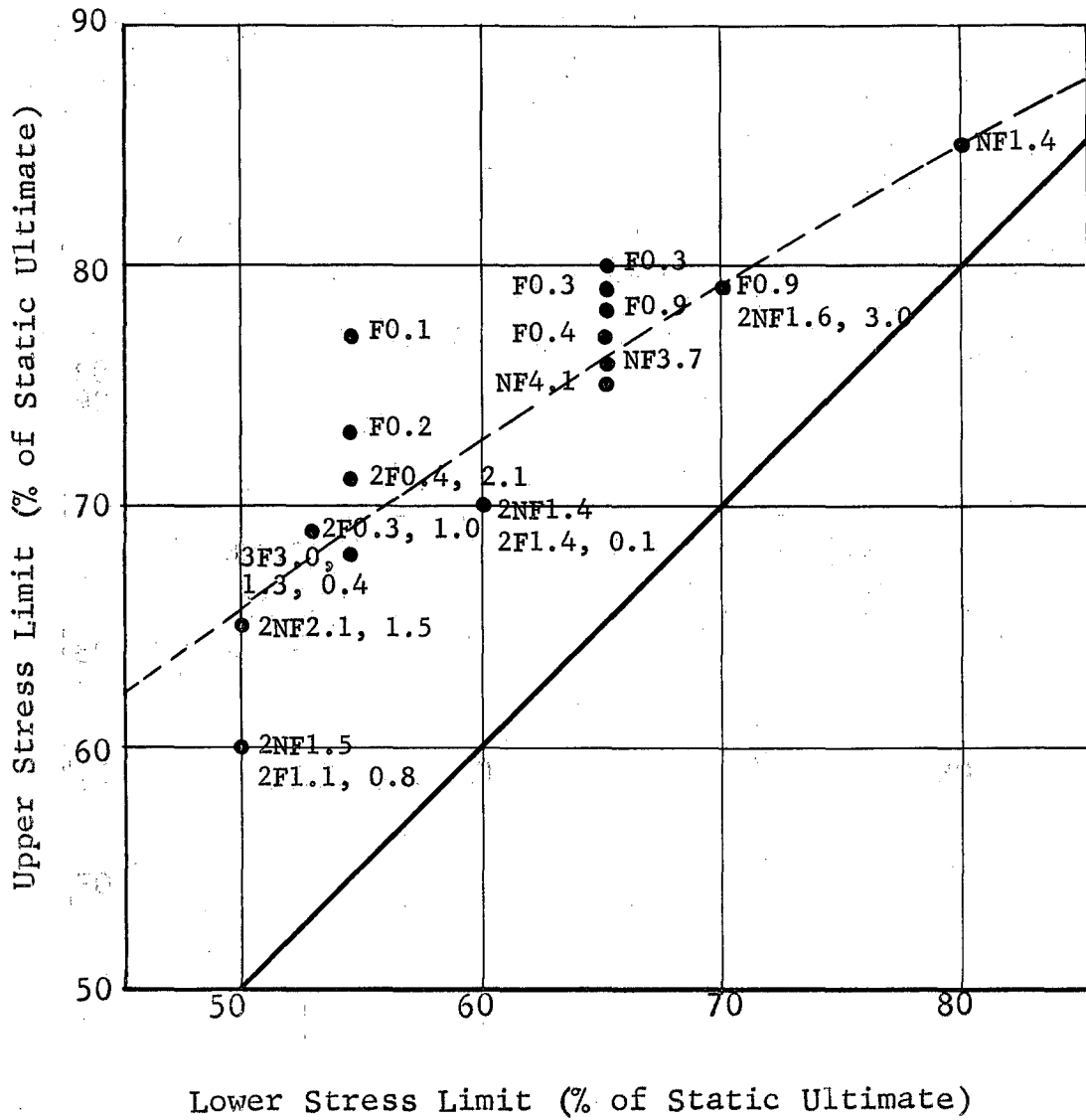

FIGURE 16 - VERIFICATION OF FATIGUE FAILURE ENVELOPE

specimens followed the predicted pattern. Nineteen specimens were tested at stress ranges plotted within the envelope, indicating endurance for at least one million cycles. Four of these failed before one million cycles, but three of these failures were of questionable value because of difficulties with the loading apparatus. Therefore, these tests seem to verify the failure envelope for the areas tested. However, before this envelope may be assumed to be verified completely, many more tests are needed.

From all of these tests one fact is definitely shown. A very sudden failure occurs with the repeated type of loading which is not in any way similar to a failure under static conditions. In the static case, a yielding and gradual necking down of the wires in the strand takes place, giving warning of impending failure. In the repeated load case no such yielding occurs. The failure is a sudden snapping of the wire with no warning. Pictures of typical fractures are shown in Figures 21 - 24. (See Appendix B).

Specimen 39 (Table II), after withstanding 4.1 million cycles of load, and specimen 41, after 3.7 million cycles, were tested statically to 111% of their catalog ultimate strength, where failures occurred. The typical static fractures are shown in Figures 22 and 23. One can see the completely different type of fracture obtained by these static tests when comparing them to the jagged type fractures obtained by repeated loading. (See other failure figures).

To guard against these sudden failures, specifications are needed to guide the designer. At present there are two major specifications in use throughout the country. One of these is the CRITERIA FOR PRESTRESSED CONCRETE BRIDGES by the Department of Commerce, Bureau of Public Roads, published in 1954. The other is the recently published TENTATIVE RECOMMENDATIONS FOR PRESTRESSED CONCRETE by the ACI-ASCE Joint Committee 323.

The first code, being an earlier publication, is of necessity quite broad and general, and no mention is made of repetitive loadings. Instead, maximum permissible stresses are given which obviously include a safety factor against static overload. Since little was known about the effects of repetitive loading at the time of publication of this code, this was the only way to safeguard the design. However, a blind figure of an allowable stress does not offer freedom of design, nor does it cover possible extreme cases.

A more detailed approach is given in the second code which contains an entire section devoted to repetitive loads. Such a code, which has been based on the current research in many fields, offers the designer a better knowledge of what the code is specifically guarding against, and allows him much more freedom in design. Section 206.3 of this code is quoted, in part, here.

"Fatigue strength of prestressing steel depends on magnitude and range of stress, and number of cycles of loading. Minimum stress is the effective prestress. Maximum stress and range of stress depend on magnitude of live loads or overloads that may be repeated. Range of stress under service loads will usually be small unless concrete is cracked. Cracking may occur if tension is permitted in concrete. Fatigue failure of steel should be considered in such cases, especially when a high percentage of ultimate strength is used for prestress."

Such a section is quite informative to the engineer, but perhaps the last sentence is a little misleading when examined in the light of this recent test program. If the fatigue failure envelope is to be assumed correct (and there is thus far no evidence from tests to prove it incorrect), then it may be found that for prestressing percentages varying from 55% to 70% the allowable amplitude of overload decreases from 14.4% to 9.8%. It is true, therefore, that a fatigue failure is slightly more critical at the higher prestress, but from the wording of the sentence used in the code, too much emphasis would appear to be taken away from the almost equally critical lower prestressing values. Perhaps a wording which places emphasis on a maximum allowable range of stress would give better results. It is hoped that the information presented in this report may aid those who are responsible for writing such codes to improve the existing codes in such areas as shown above.

Creep

In addition to the data already discussed, attempts were made to obtain information about creep due to repeated loading in all but one of the tests. Several typical curves are shown in Figures 18 - 20. (In Appendix A). Upon looking at these curves, one immediately becomes alarmed at the creep ordinates shown. These are excessively high and are not due to high amounts of creep, but to slip of the strand which could not be separated from the creep. A description of this phenomenon should clarify the above statements.

As a test begins, a static test is conducted to calibrate the creep gages. These gages actually measure the changes in distance between two blocks at two diagonally opposite corners of the blocks which, when averaged, give the elongation in the strand over the set gage length. As the test enters its dynamic phase, the bond between strand and grout breaks. If the Strandvise is not tight enough, a gradual slipping of the strand takes place. Due to the nature of the impressions in the grout, the strand, in order to slip through the grout, must twist, giving a spiraling effect.

As the strand spirals through the grouted zone, the twisting causes a rotation of the gage blocks. This has two effects on the creep readings, both of which tend to increase the values.

The first and smaller of the two, involves the changing of the constant by which actual strains are obtained. Originally the change in elongation of the strand is detected by measuring a slight deflection normal to the surfaces of the blocks. After rotation of the blocks, this deflection is no longer normal to the surfaces of the blocks and thus, for the same change in elongation of the strand, a larger deflection is recorded as creep.

The second effect, which may amount to an error which is equal to or greater than the actual creep itself, is that caused by the rotation of the block itself. At any given constant elongation of the strand, as the block rotates, the distance between any two previously vertically aligned points increases. This increase in distance is also recorded as a creep deflection.

At first, attempts were made to establish a linear relationship between the amount of rotation and the linear distance slipped. This, however, was found to be useless because of another aspect of this slip. Due to large plastic deformations of the grout ridges, it was found that occasionally a linear slip was recorded with no accompanying rotation of the blocks.

In Appendix C of this report, methods of correcting future tests so as to guard against this slip error are proposed. It was developed at too late a date to be incorporated in this test program, however.

Figure 19 shows clearly how great an effect this slip has on the creep measurements. Specimen 39 was tested at a stress range of 65.2% to 75.0% of static ultimate strength, and at 16 hours had reached a recorded creep value of 1150 microinches per inch. Specimen 41, tested at a higher range of 65.2% to 75.9% after the same 16 hours, had only reached 1053 microinches. And specimen 42, tested at an even higher range of 65.2% to 78.1%, recorded a creep value of 720 microinches per inch after the same 16 hours' time.

This, of course, is not logical. In all other major studies of creep, the elongations at any given time have been higher as the loading has been increased. If one assumes the creep curve for specimen 42 to be correct, and also assumes that the creep curves for lower maximum loads should have no greater ordinates than the curve of specimen 42, then the error in specimen 39, caused by slip, would be approximately 430 microinches per inch, or about 60%. This is indeed a large error and may even be larger due to the fact that the possibility of slip in specimen 42 has not been ruled out.

The creep values have been shown to be excessively high due to the slip phenomenon, but these erroneous values are still on the safe side. If a designer used the values shown in Figures 18 - 20 to limit his allowable stresses, then there would be a factor of safety or, in this case, a factor of ignorance of approximately 1.6. This, however, should be only a temporary measure until additional tests are run, with a slip correction taken into account.

CHAPTER IV

APPLICATION OF THE FATIGUE FAILURE ENVELOPE
TO BEAM DESIGN

For the bridge designer, it would be quite enlightening to visualize the percentages of static ultimate strength of a strand shown in this report, on a failure envelope as moments on a beam. To be able to see these maximum and minimum repetitive load stresses, in terms of moments which might cause them, would add a great deal to the understanding of the usefulness and the importance of the information reported here.

Until recently, an accurate solution of a prestressed beam with a cracked section consumed a great deal of time and so it would have been almost impossible to make such a valuable addition to this report. However, a recent paper by Mr. R. F. Warner simplifies these calculations for solid rectangular sections through use of an intercept chart¹. This method of solution will not be explained here, but it will be used to show, in terms of moment on a beam, what a stress range used on the fatigue failure envelope might mean. The example on the following page, along with many of the numerical values, are from Mr. Warner's report.

- - - - -
1. R.F. Warner, THE CALCULATION OF FLEXURAL STRESSES IN A PRESTRESSED CONCRETE MEMBER, unpublished report, Lehigh University Institute of Research, 1958, p. 31

Given a concrete beam of dimensions shown,
the relevant data are:

$$b = 8 \text{ in.}$$

$$h = 18 \text{ in.}$$

$$d = 13 \text{ in.}$$

$$A_s = 0.653 \text{ in}^2$$

$$f'_c = 6260 \text{ psi}$$

$$F_i = 96.33 \text{ kips, } f_{si} = 147.5 \text{ kips/in}^2 = 59.3\% \text{ stat. ult.}$$

$$F_o = 92.47 \text{ kips, } f_{so} = 141.3 \text{ kips/in}^2 = 57.1\% \text{ stat. ult.}$$

$$F_{eff} = 85.73 \text{ kips, } f_{se} = 131.2 \text{ kips/in}^2 = 52.9\% \text{ stat. ult.}$$

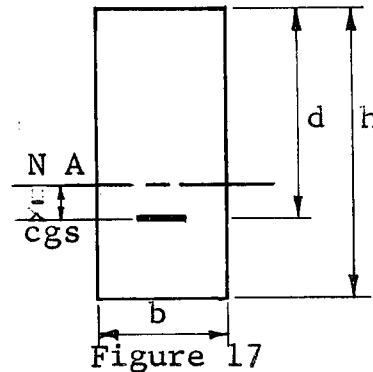

For the uncracked section:

$$\text{eccentricity of steel } \bar{x} = 3.93 \text{ in.}$$

$$I = 3939 \text{ in}^4$$

Calculated design working moment (zero tensile stress in concrete):

$$M_w = 612 \text{ 000 in-lb.}$$

Calculated cracking moment
(assuming $f'_t = 7.5\sqrt{f'_c} = 592 \text{ psi}$):

$$M_{cr} = 872 \text{ 000 in-lb.}$$

Using the intercept chart for moments above cracking,
the following stress-moment table is obtained.

TABLE IV Stress Moment Relationships

| f_s <u>ksi</u> | f_s/f_u <u>%</u> | M <u>in-kip</u> | M/M_w <u>_____</u> |
|---------------------|-----------------------|---------------------|-------------------------|
| 131.2 | 52.9 | effective prestress | |
| 160 | 60.4 | 1035 | 1.69 |
| 180 | 68.0 | 1260 | 2.06 |
| 200 | 75.6 | 1430 | 2.34 |
| 210 | 79.4 | 1512 | 2.49 |
| 220 | 83.2 | 1598 | 2.61 |

From the fatigue failure envelope for one million cycles, one may see that the maximum permissible percentage of ultimate strength for a minimum of 52.9% is 68.0%. Using the above table, this percentage converts to an applied moment of 1260 in-kips, or 2.06 times the design working load moment. Therefore, one may see that this specific beam could sustain one million repetitions of an overload moment equal to twice its working load moment.

With similar calculations for the actual case, the designer, through use of the fatigue failure envelope, could calculate the maximum safe repetitive overload possible on the given structure and thus guard against this occurrence.

CONCLUSION

The main purpose of this investigation has been to provide information for the safer and more accurate design of prestressed concrete members. The major results are summarized below.

1. S-N curves were determined for two minimum stresses of 54.5 and 65.2 per cent of the static ultimate strength of the strand. The maximum deviation of any point from the plotted curves was 4.87 per cent. Both curves seemed to level out at about 800 000 cycles, indicating that a safe design could be based on the one million cycle stress level.
2. The proposed fatigue failure envelope for one million cycles was substantially correct in predicting the behavior of the specimens tested. Three of the twenty-six specimens used in the final analysis did not conform with the envelope; two exceeded the predicted fatigue life, and one fell short.
3. The fatigue failure of a strand was found to occur without visible warning. No necking down was observed, nor was there any other sign of impending failure which could be detected.
4. Creep under repetitive loading was found to follow the same general trend as it does under static loading, but a comparison of creep values was made impossible by the inclusion of slip in the recorded data.
5. Further investigations into both fatigue and creep under repeated loading are recommended.

APPENDIX A

CREEP CURVES FOR 7/16" STRANDS

UNDER REPEATED LOADING

The curves presented in this section are entitled creep curves. However, the reader should keep in mind the fact that large slip readings were included in the recorded creep data and, as these two values could not be separated, the creep ordinates shown here are greatly exaggerated.

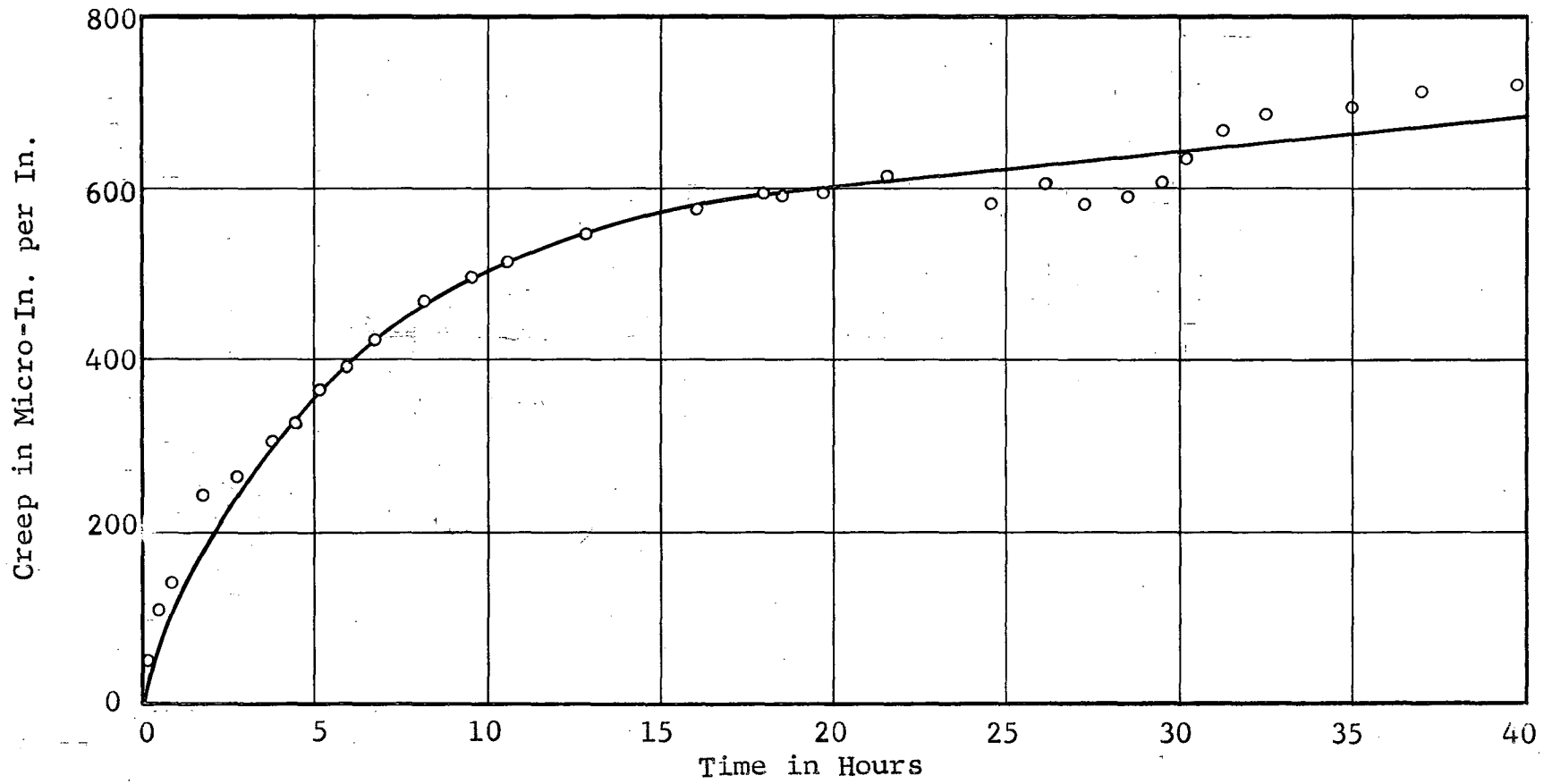

FIGURE 18 - CREEP CURVE DUE TO REPETITIVE LOADING OF
 54.5-68.0% OF STATIC ULTIMATE (SPECIMEN 31)

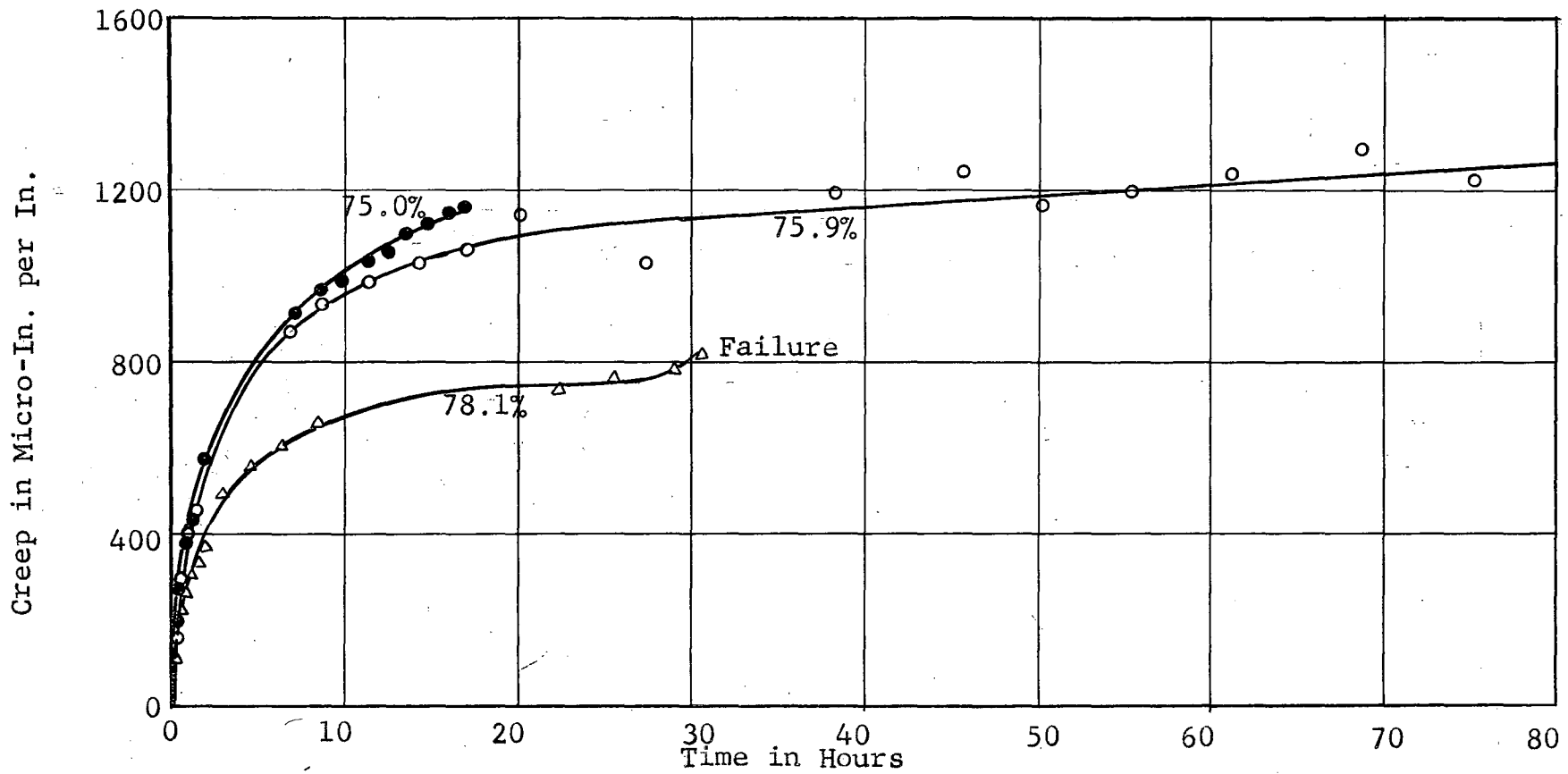

FIGURE 19 - CREEP CURVES DUE TO REPETITIVE LOADING WITH A CONSTANT MINIMUM STRESS OF 65.2% OF STAT. ULT. AND VARYING MAXIMUM STRESSES

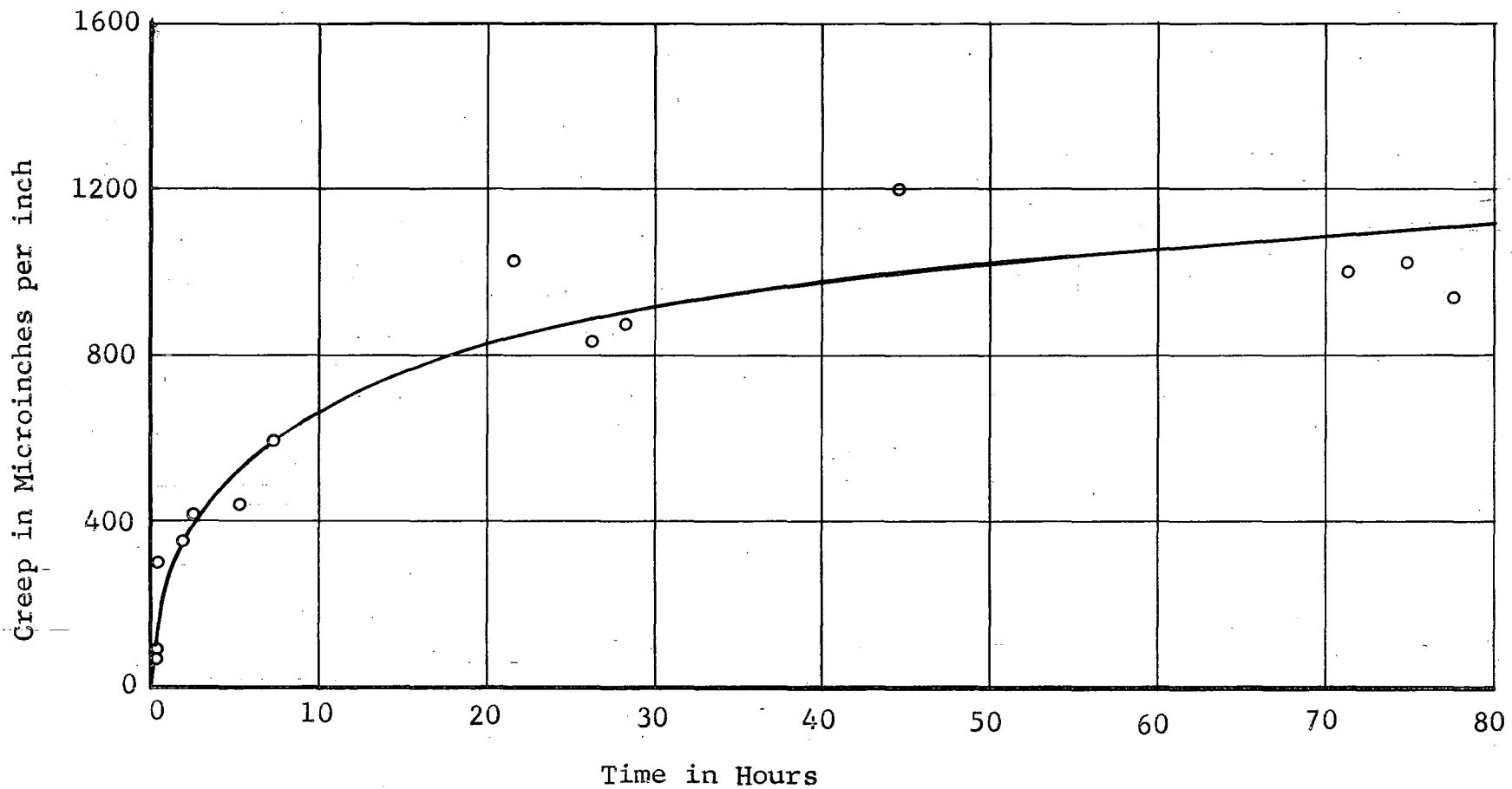

FIGURE 20 - CREEP CURVE DUE TO REPETITIVE LOADING OF
50.0 - 60.0% OF STATIC ULTIMATE (SPECIMEN 14)

APPENDIX B

PHOTOGRAPHS OF TYPICAL FATIGUE
AND STATIC FAILURES

Specimens with static failures are numbers 39 and 41, shown in Figures 22 and 23. All other specimens shown have fatigue failures.

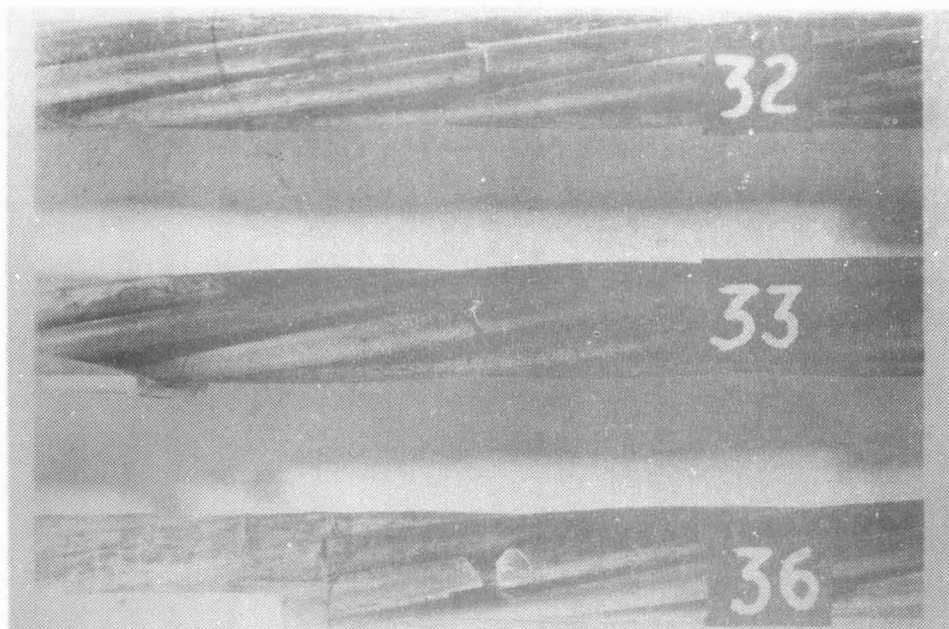

FIGURE 21 - FAILURES OF SPECIMEN NOS. 32, 33, 36

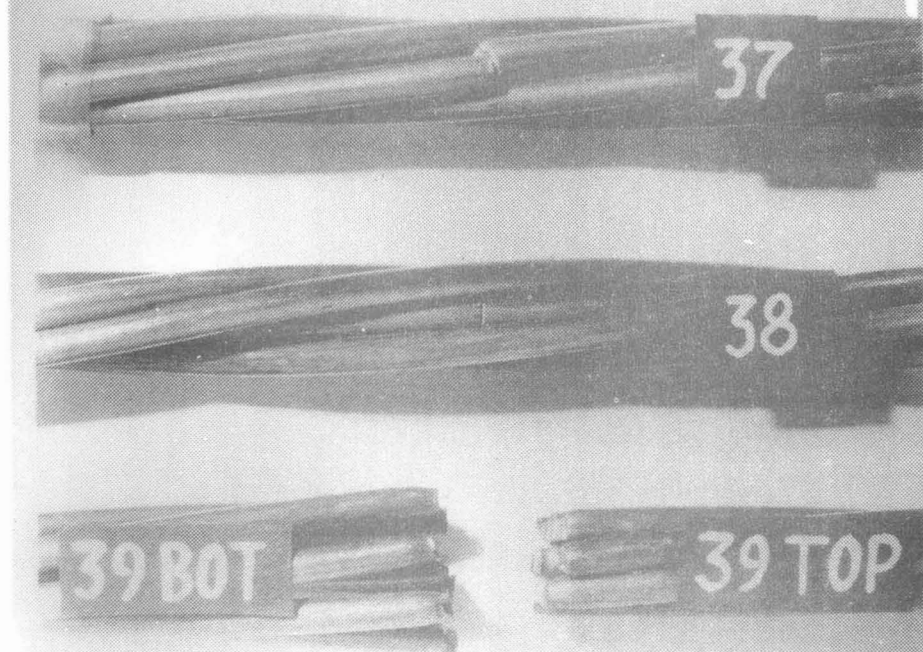

FIGURE 22 - FAILURES OF SPECIMEN NOS. 37, 38, 39

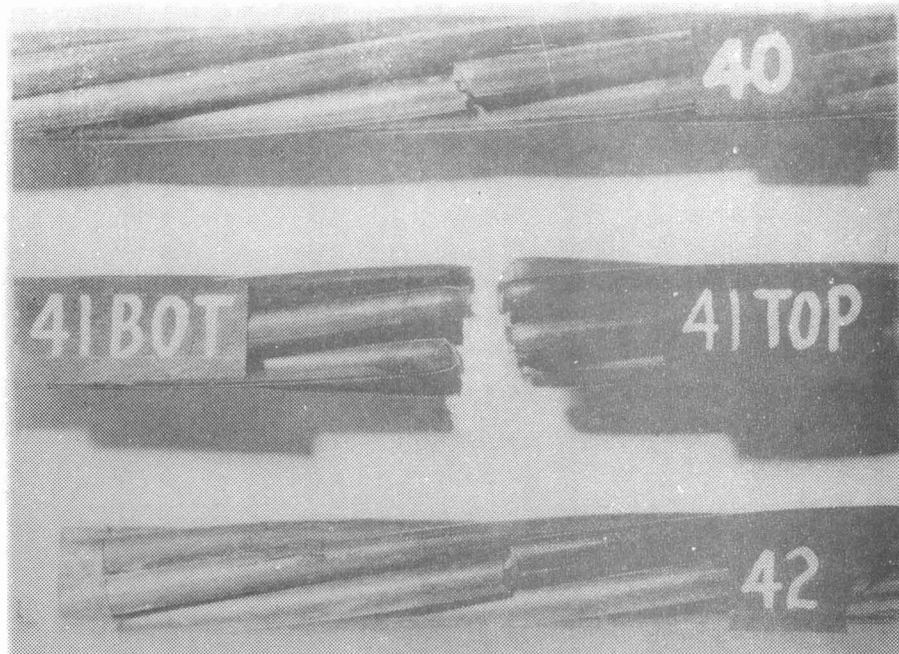

FIGURE 23 - FAILURES OF SPECIMEN NOS 40-42

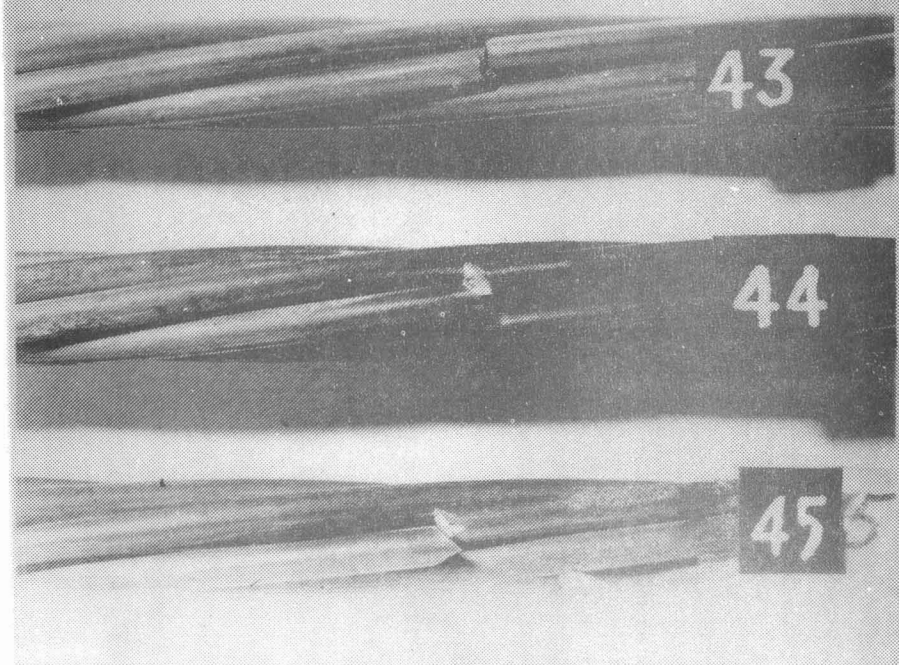

FIGURE 24 - FAILURES OF SPECIMEN NOS 43-45

APPENDIX C

POSSIBLE PROCEDURE FOR
ELIMINATING INACCURACIES DUE TO SLIP

As was discussed in Chapter III, gross inaccuracies in the creep measurements were caused by the slip of the strand through the grouted end sections. There are several methods of remedying this situation, and they will be discussed here.

Four possible methods are immediately brought to mind, two of which are an attempt to stop the slip completely, and two of which allow slip but are methods of correcting for it. One, or perhaps a combination of these methods may constitute a solution to this problem for further tests.

The first of these methods is simply to lengthen the specimen, thus providing for an additional bond length. This would of course, eliminate the slip completely, provided a suitable length could be found. It would probably be the method which solves the problem in a manner most nearly simulating the actual case in a full size beam where slip occurs only in very rare instances. However, it does present problems due to an increase in size. Increased specimen length means a change in the specimen holders now being used, a change in the testing rig to allow larger specimens, and involves difficulties in placing the specimen in the new test rig. These problems are all readily

solvable, and thus this may be the simplest solution to the problem.

The second method involves the use of special clamps similar to the normal retaining rings used in industry. Such a ring would be clamped on the strand about every 6 or 8 inches of length in the grouted zone. This ring would offer a great deal of resistance to longitudinal displacement, and at the same time not allow the strand to rotate because of its own resistance to rotation. Such a ring is shown in Figure 25.

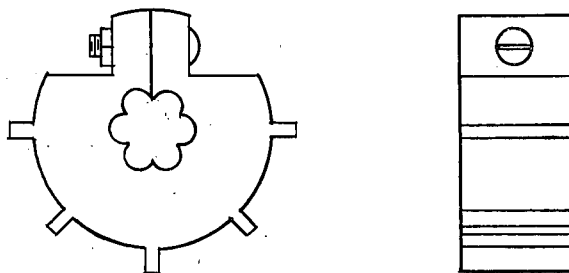

Figure 25 Retaining Ring Clamp

This method offers the advantage of eliminating slip while still keeping the length of the specimen the same, thus allowing all present test equipment and methods to remain unchanged. However, the method does not simulate the actual beam case as well as the first method because of the bond concentration within the length rather than the gradual bond buildup in the case of the beam.

Another problem caused by use of this method is in grouting. Grouting rods similar to those used so effectively in this series of tests, will not be applicable to this new situation due to the large diameter of the rings which would restrict the packing of the grout. Some alteration to the ring or the grouting procedure must be made, but with the proper alteration this method might be used with great success.

The third method offers little change to the present procedure and equipment, as it allows the amount of slip to occur which has normally been occurring during tests thus far conducted. It consists merely of a specially constructed and graduated disk and two sharp pointers. The disk (see Figure 26a) is placed on the top edge of the lower pipe section of the specimen, with care to be certain it is concentric with the center of the strand. The disk is graduated in degrees with a mirrored surface attached for elimination of parallax. Each pointer is attached to one of the creep block clamps along a radial line emanating from the strand center. (See Figure 26b). When the blocks are first placed in position, an initial reading on the disk below each pointer is obtained, the mirror surface eliminating all parallax. Then, with the original perpendicular distance between each pair of gage points known, a simple reading of these pointers at convenient time intervals will enable the testing engineer to determine the amount of error

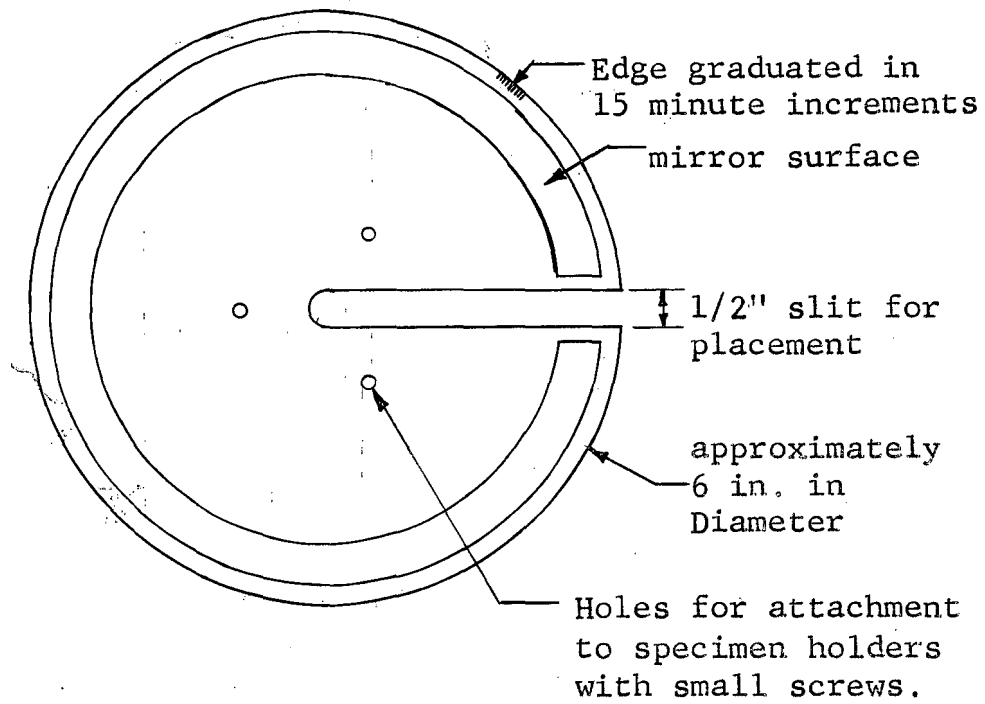

FIGURE 26 (a): GRADUATED DISK FOR SLIP MEASUREMENT

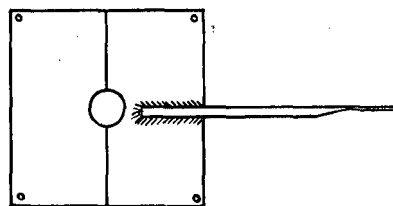

FIGURE 26 (b): POINTER ATTACHMENT FOR BLOCKS

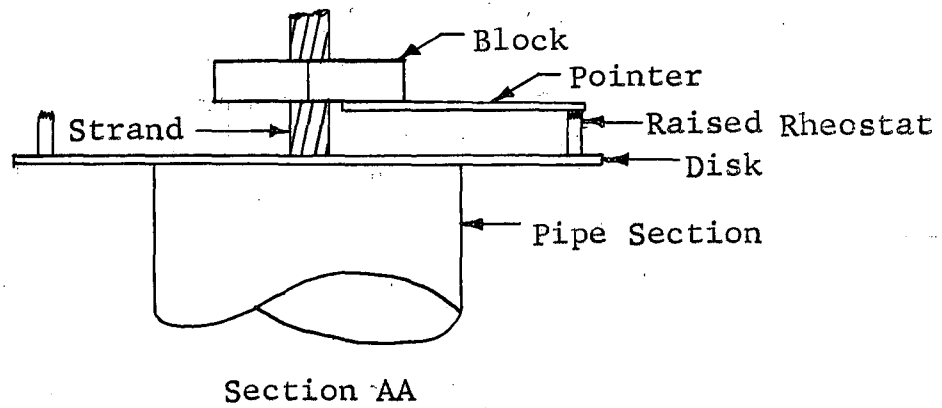
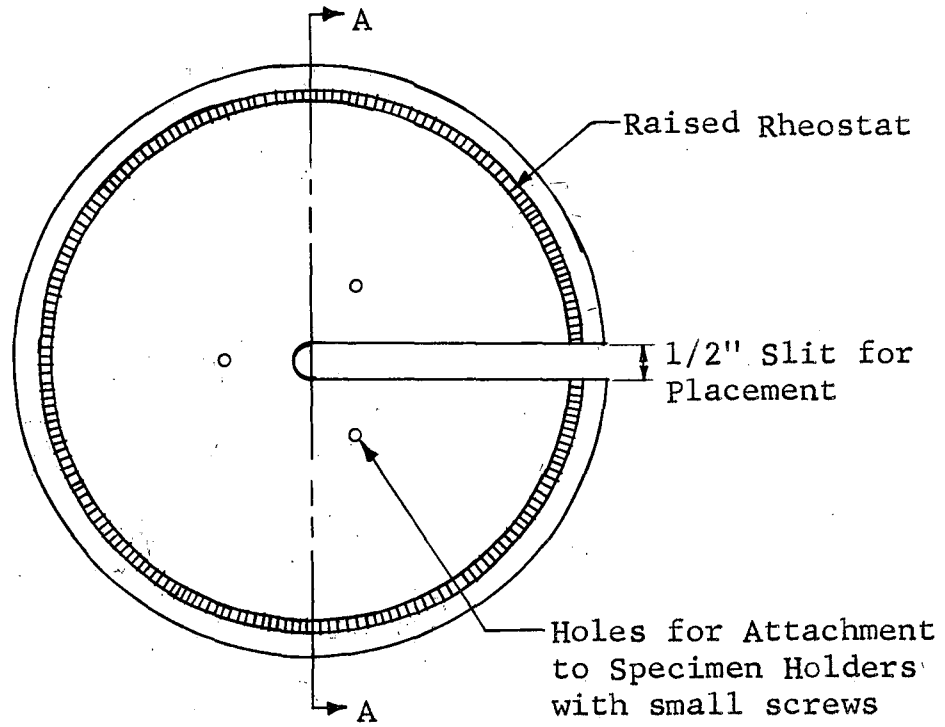

FIGURE 26(c): SLIP MEASUREMENT DISK WITH RAISED RHEOSTAT

in the creep readings due to slip. If a continuous recording is desired, then a slight modification of this same setup could be used. Instead of only one disk there would be two, each attached to a pipe section and each fitted with a raised rheostat (see Figure 26a) so that contact could be made with the pointer. An electrical circuit with variable resistance could then be formed which could be calibrated very accurately and fed into the Brush recorder along with the creep gage readings.

This method, with its alternate system, seems to offer simplicity of preparation and also the advantage of continuous recording. It does not require any major changes to be made in the specimens or in any of the preparation or testing procedures. However, the major disadvantage is that the slip is allowed, and thus additional calculations are required before obtaining the creep data.

The fourth method, like the third, offers little change to the present procedure, as it too allows slip to occur and merely offers a method of eliminating the error caused by this slip. For this method two small mirrors, two light sources, and two scales are needed. One mirror is mounted on each creep block clamp, perpendicular to any radius from the center of the strand. (See Figure 27a). A light source adapted to emit a slit of light, shines on the mirror and its reflected ray

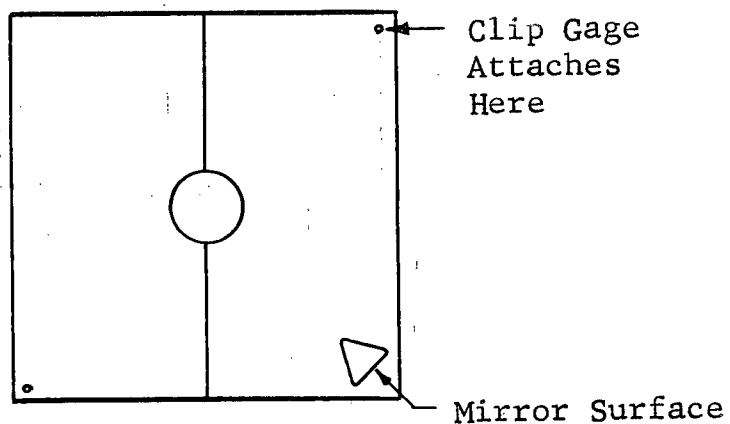

FIGURE 27(a): BLOCK CLAMP WITH MIRROR ATTACHMENT

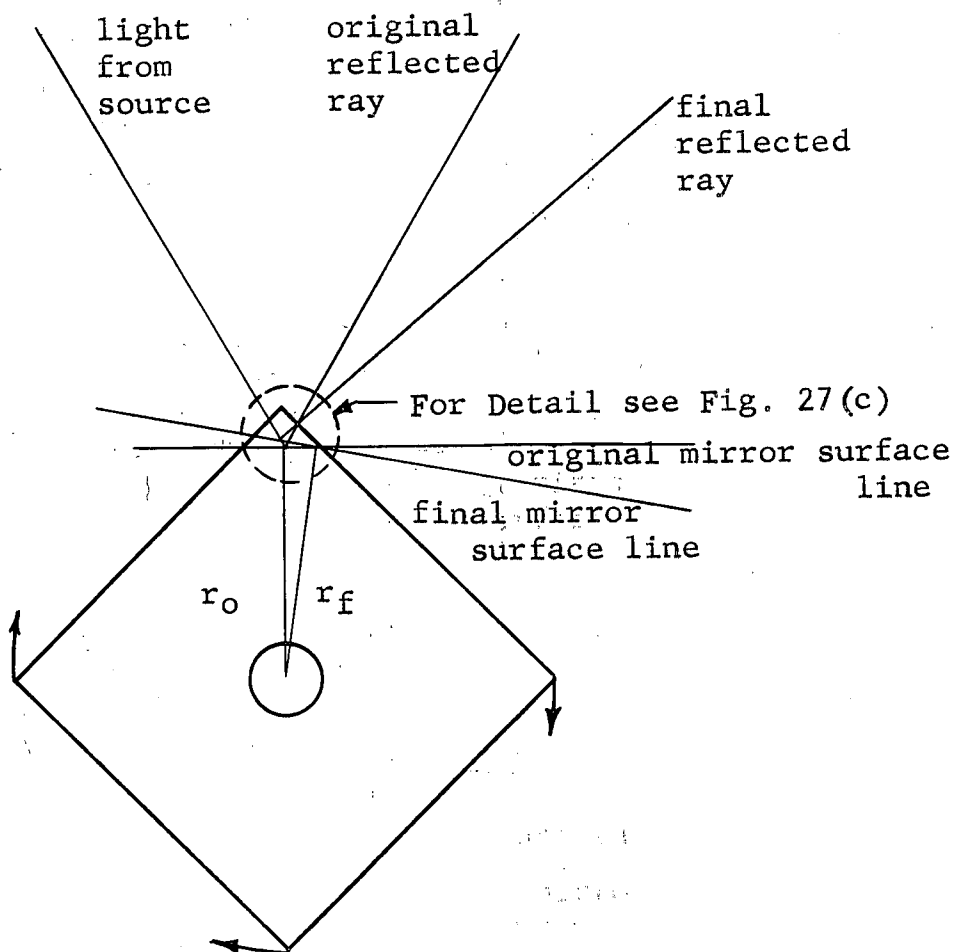

FIGURE 27(b): DETERMINATION OF BLOCK ROTATION

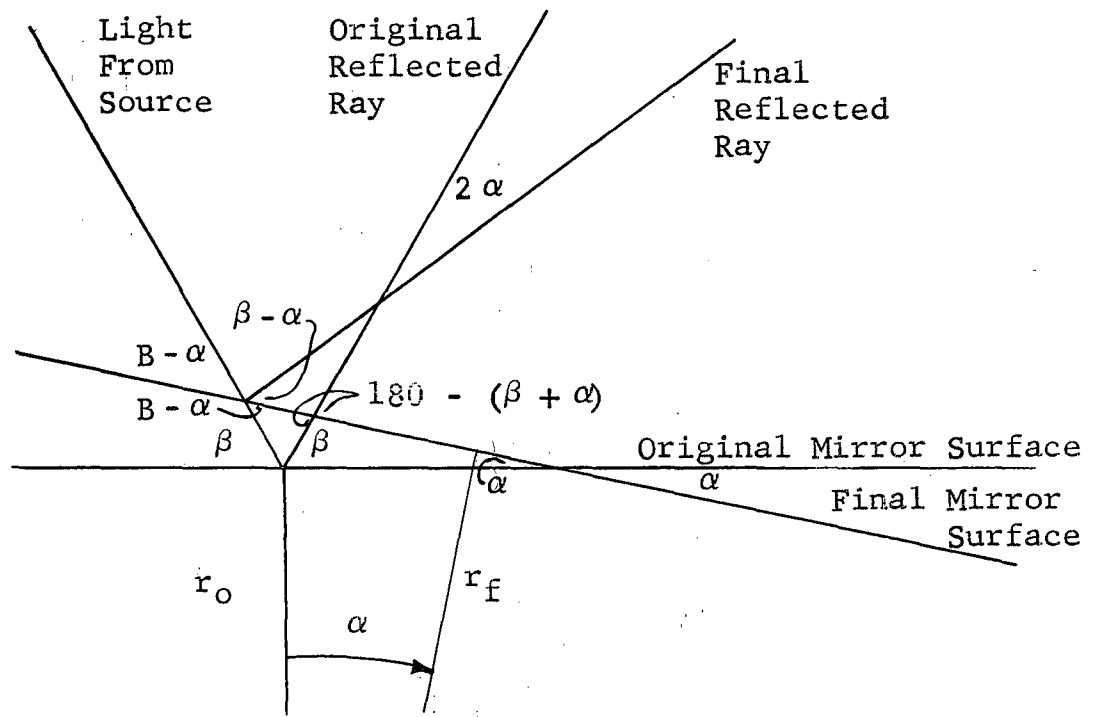

FIGURE 27(c): GEOMETRICAL CONSIDERATIONS

shines on a scale which is then made perpendicular to the ray of light. As the block rotates, the reflected light ray moves along the scale. For a given block rotation α , it can be shown that the angle change in the reflected light ray is equal to 2α . (See Figure 27b and 27c). Knowing the distance between the mirror and the scale, one may calculate the angle 2α and thus α is known.

This method has the advantage of being very lightweight, thus causing little eccentricity of pressure on the strand. Also, like number three, there is little change involved in the specimens themselves or in the original test procedure. However, this method has the disadvantage of being very complicated to set up originally, and all readings must be taken visually. This means someone would have to remain with the test 24 hours a day.

Any one of these four methods could be used with considerable success if the problems and disadvantages were remedied. It is hoped that future tests may include some feature such as explained above, to eliminate slip errors from the final creep curves.

BIBLIOGRAPHY

1. Abeles, P.W.: FATIGUE RESISTANCE OF PRESTRESSED
CONCRETE BEAMS, Final Report
International Association for Bridge
and Structural Engineers, Portugal, 1957
2. Abeles, P.W.: SOME NEW DEVELOPMENTS IN PRESTRESSED
CONCRETE
The Structural Engineer, Vol.29, No.10, Oct.1954
3. Abeles, P.W.: STATIC AND FATIGUE TESTS ON PARTIALLY
PRESTRESSED CONCRETE CONSTRUCTION
Journal of the American Concrete Institute
Vol. 26, Dec. 1954
4. ACI-ASCE Joint Committee 323, TENTATIVE RECOMMENDA-
TIONS FOR PRESTRESSED CONCRETE
Journal of the American Concrete Institute
Vol. 29, Jan. 1958
5. Billig, J. PRESTRESSED CONCRETE
The Macmillan Company, New York, 1952
6. Bureau of Public Roads: CRITERIA FOR PRESTRESSED
CONCRETE BRIDGES
U.S. Government Printing Office,
Washington, D.C. 1954
7. Eastwood, W.: FATIGUE TESTS ON LEE-McCALL
PRESTRESSED CONCRETE BEAMS
Civil Engineering and Public Works Review
Vol.52, No.613, July 1957
8. Ekberg, C.E., Jr.: REPORT ON DYNAMIC TESTING
OF A 55-FT. AMDEK BRIDGE MEMBER
for Concrete Products of America Division
of American-Marietta Company, Pottstown,
Pennsylvania (not published) 1956
9. Ekberg, C.E., Jr; Walther, R.E; Slutter, R.G:
FATIGUE RESISTANCE OF PRESTRESSED
CONCRETE BEAMS IN BENDING
Journal of the Structural Division of the
American Society of Civil Engineers
Vol.83, No.ST4, July 1957
10. Eney, W.J; Loewer, A.C., Jr: STEEL WIRE FOR
PRESTRESSED CONCRETE - DISCUSSION
Proceedings of the First United States
Conference on Prestressed Concrete
pp. 158-60 Aug. 1951

11. Everling, W.O: STEEL WIRE FOR PRESTRESSED CONCRETE
- DISCUSSION
Proceedings of the First United States
Conference on Prestressed Concrete
pp. 161-66 Aug. 1951
12. Freyssinet, E.A: A REVOLUTION IN THE TECHNIQUES
OF THE UTILIZATION OF CONCRETE
The Structural Engineer, Vol.14, No.5, May 1936
13. Gifford, F.W: CREEP TESTS ON PRESTRESSING CONCRETE
Magazine of Concrete Research
pp.71-4, No.14, Dec.1953
14. Godfrey, H.J: THE PHYSICAL PROPERTIES AND METHODS
OF TESTING PRESTRESSED CONCRETE
WIRE AND STRAND
Journal of the Prestressed Concrete Institute
Vol. 1, No.3, Dec. 1956
15. Godfrey, H.J: STEEL WIRE FOR PRESTRESSED CONCRETE
Proceedings of the First United States
Conference on Prestressed Concrete
pp. 150-57, Aug. 1951
16. Guyon, Y: PRESTRESSED CONCRETE
John Wiley & Sons, Co., Inc. New York, 1955
17. Hempel, M: FATIGUE TESTS ON STEEL WIRE
Draht, English Edition No.23, pp. 28-33, June 1956
18. Hempel, M. & Tillmanns: VERHALTEN DES STAHLER
BEI HOHEREN TEMPERATUREN UNTER
WECHSELNDER ZUGBEANSPRUCHUNG
Mitteilungen, K. Wilhelm, Inst. Eisenforschung,
pp. 163-82, Vol. 18, 1936
19. Inomata, S: ON A BENDING FATIGUE TEST OF
PRESTRESSED CONCRETE BEAMS
Journal of the Japanese Society of Civil Engineers
Vol.37, No.10, Oct. 1952
20. Knudsen, K.E. & Eney, W.J: ENDURANCE OF A FULL-SCALE
PRETENSIONED CONCRETE BEAM
Prestressed Concrete Bridge Members
Progress Report 5,
Lehigh University Institute of Research
(not published) Apr. 1953

21. Komendant, A.E: PRESTRESSED CONCRETE STRUCTURES
McGraw-Hill Book Company, Inc., New York, 1952
22. Large, G.E: BASIC REINFORCED CONCRETE DESIGN:
ELASTIC AND CREEP
2nd ed., Ronald Press Co., New York, 1957
23. Lazan, B.J: DYNAMIC CREEP AND RUPTURE PROPERTIES
OF TEMPERATURE-RESISTANT MATERIALS
UNDER TENSILE FATIGUE STRESS
Proceedings of the American Society for
Testing Materials, Vol.49, pp. 757-87 1949
24. Lin, T.Y: DESIGN OF PRESTRESSED CONCRETE
STRUCTURES
John Wiley & Sons, Inc., New York, 1956
25. Lin, T.Y: STRENGTH OF CONTINUOUS PRESTRESSED
CONCRETE BEAMS UNDER STATIC AND
REPEATED LOADS
Proceedings of the American Concrete Institute
26. Magnel, G: CREEP OF STEEL AND CONCRETE
IN RELATION TO PRESTRESSED CONCRETE
Journal of the American Concrete Institute,
No. 6, pp. 485-500 Feb. 1948
27. Magnel, G: NOUVEL ESSAI DE FATIGUE D'UNE POUTRE
EN BETON PRECONTRAINTE
Science et Technique No. 8/8 1953
28. Magnel, G: PRESTRESSED CONCRETE
3rd ed., McGraw-Hill Book Company, Inc.
New York 1954
29. Nuwaysir, F.S: FATIGUE STUDY OF PRESTRESSED CONCRETE
BEAMS AND THEIR COMPONENTS
unpublished report, Lehigh University, 1958
30. Ozell, A.M. & Ardaman, E: FATIGUE TESTS OF
PRETENSIONED PRESTRESSED BEAMS
Journal of the American Concrete Institute
Vol.28, No.4, Oct. 1956
31. Ros, M: VORGESPANNTER BETON (Bericht Nr.155)
Eidgenössische Materialprüfungs- und
Versuchsanstalt S 79, Abb.78, Zurich 1946

32. Shelton, S.M. & Swanger, W.H:
FATIGUE PROPERTIES OF STEEL WIRE
Journal of Research of the National Bureau
of Standards Vol. 14, Jan. 1935
33. Slutter, R.G. & Ekberg, C.E., Jr:
STATIC AND FATIGUE TESTS ON
PRESTRESSED CONCRETE RAILWAY SLABS
Lehigh University Institute of Research 1957
(not published)
34. Smislova, A. & Others: ENDURANCE OF A FULL-SCALE
POST-TENSIONED CONCRETE MEMBER.
Prestressed Concrete Bridge Members
Progress Report 6 (not published)
Lehigh University Institute of Research 1954
35. Spare, G.T: CREEP AND RELAXATION OF HIGH STRENGTH
STEEL WIRES AT ROOM TEMPERATURES
Wire and Wire Products, Oct. 1952
Vol.27, No.10, pp.1058-61; 1119-20
36. Stephenson, H.K. & Jones, T.R., Jr:
METHOD PRESENTED FOR COMPUTING
STEEL PRESTRESS LOSSES
Texas Engineering Experiment Station Report
Aug. 1955
37. Zinsser, R: THE CREEP OF STEEL WIRE UNDER
PULSATING TENSILE STRESSES
Stahl und Eisen p. 145 Jan. 1954