

## Lehigh University Lehigh Preserve

---

Fritz Laboratory Reports

Civil and Environmental Engineering

---

1934

# Program and specifications for seat angle research, 1934

N. G. Schreiner

Follow this and additional works at: <http://preserve.lehigh.edu/engr-civil-environmental-fritz-lab-reports>

---

### Recommended Citation

Schreiner, N. G., "Program and specifications for seat angle research, 1934" (1934). *Fritz Laboratory Reports*. Paper 1167.  
<http://preserve.lehigh.edu/engr-civil-environmental-fritz-lab-reports/1167>

This Technical Report is brought to you for free and open access by the Civil and Environmental Engineering at Lehigh Preserve. It has been accepted for inclusion in Fritz Laboratory Reports by an authorized administrator of Lehigh Preserve. For more information, please contact [preserve@lehigh.edu](mailto:preserve@lehigh.edu).

~~170B3~~

166.3

FRITZ ENGINEERING LABORATORY  
LEHIGH UNIVERSITY  
BETHLEHEM, PENNSYLVANIA

PROGRAM AND SPECIFICATIONS  
FOR SEAT ANGLE RESEARCH  
by Norman G. Schreiner

PROGRAM AND SPECIFICATIONS FOR  
SEAT ANGLE RESEARCH

by Norman G. Schreiner\*

-----

A. GENERAL INFORMATION

1. Purpose - The investigation in seat angles is projected in an endeavor to obtain reliable information upon which a rational theory of design may be based for their economic use in welded structures.

A study of available literature and tests has been made and little information regarding the design of beam seats has been found. Such design as is being done, is by empirical formula and rule of thumb methods supported by practical experience.

It is purposed in the following program to study the problems connected with:

- (a) Seat Angles (plain beam seats), stress distribution, economic connections and limits of application
- (b) Seat Angles with top angles
- (c) Seat Angles with stiffeners
- (d) Miscellaneous connections similar to the seat connection.

2. Facilities for Fabrication and Testing - The facilities of the Fritz Engineering Laboratory, Lehigh University, Bethlehem, Pennsylvania, will be available for all testing. It is proposed to have the fabrication done either in the Fritz Laboratory or in the shop of McClintic-Marshall Corporation at Bethlehem, Pennsylvania.

3. Program - The present program covers the simple beam seat connection. The specimens are of an elemental type designed with the object of studying:

- (a) The strength of the weld under uniform line loading along the outstanding leg, followed by more concentrated loading.
- (b) Effect of Length of Vertical Leg
- (c) Effect of Thickness of Angle
- (d) Effect of Size of Weld
- (e) Effectiveness of the Shielded-Arc Process
- (f) Full-sized connections for proof test of combinations of above variables.

The specimens are to be subjected to static tests for ultimate strength and yield point. It is desirable to record the deflections and slopes of the outstanding legs and the deformations in the welds under varying lever arms before the test to destruction is made.

-----  
\* American Bureau of Welding Research Fellow  
Lehigh University, Bethlehem, Pennsylvania

The program outlined follows very closely that which has been proposed by Mr. H. M. Priest. The main additions are the specifications for full size connections and an expansion of Series A, to include studies of the effectiveness of the shielded arc process and the effect of the size of the weld,

4. General - The specifications and test program here outlined are written as a guide to cover the major points of the research. As experimentation shows certain tendencies, it will probably be necessary to change the type of test specimen in order to clarify those points on which there is inadequate information. However, the general plan will be adhered to as follows:

- (a) Qualification and control specimens for each size of weld.
- (b) Test specimens whereby each variable may be studied in turn
- (c) Full-sized structural connections

#### B. QUALIFICATION OF WELDERS

1. Direct Current Metal Arc Process - The following specification recommends the procedure to be followed in qualifying the welders designated by the shop to weld the test specimens.

The shop shall prepare the qualifying specimens for welding, using machine tools only, in accordance with specifications herein. The allowable tolerance for the squareness of welded surfaces shall be  $\pm 5^\circ$ . The welding electrode shall conform to specifications hereinafter cited.

The plates shall be tacked as shown on the drawings, or clamped so as to insure correct alignment of the component parts after welding.

Where more than one layer of weld metal is specified for a joint, the surface of each deposited layer shall be carefully cleaned of scale, either with a stiff wire brush or by chipping.

Form 1000 shall be filled out by the inspector.

2. The Qualification Tests Are As Follows:

(a) The preliminary tests proving the manual skill of the operator shall be omitted unless there is evident need for them, in which case the operator shall be required to perform tests as given under sections 2-4-1 and 2-4-2-1 or 8-1-1 of the Report of Structural Steel Welding Committee of the American Bureau of Welding.

(b) The mandatory test for all operators shall be the end fillet weld test of the form specified in section 8-1-2-2 of the above report. This type of specimen shall be known as the Qualification Specimen.

(c) There shall also be required from each operator an end-fillet weld test of the form below for each size of fillet weld as required by the specimen data sheets. This type of specimen shall be known as the Control Specimen.

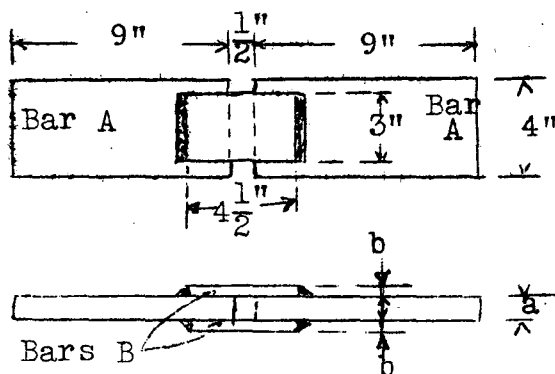

Size of Weld	Thickness of Bars		No. of Layers
	a	b	
1/2"	1"	1/2"	2
5/8"	1"	5/8"	2
3/4"	1-1/4"	3/4"	3

3. Identification Marks - Each qualification specimen shall be stamped with an identifying mark at each end, using letters and numerals not less than 1/4" high. An explanation of the identifying mark is given below.

- A - Letter for Shop Designation
- B - Letter for Welders Designation
- 3 - Size of weld in eighths
- 2 - Number of the test specimen
- H - Horizontal position of specimen during welding
- V - Vertical position of specimen during welding

4. Required Tensile Strength - The minimum ultimate strength for a 3/8-inch qualification specimen when tested in tension should be 12,000 lb. per inch of weld equivalent to a total load on the specimen of 72 kips. The yield point, the ultimate strength, and the appearance of fractured specimen shall be recorded.

Like data should be secured from the tensile tests of the control specimens. The minimum strengths to be obtained are:

Size of Fillet	Load per inch of Weld	Total Min. Load on Specimen
1/2"	16,000	96,000 lb.
5/8"	20,000	120,000 lb.
3/4"	24,000	144,000 lb.

Tests of welds made by the shielded arc process should show strengths twenty per cent greater than above.

C. WELDING SPECIFICATIONS FOR TEST SPECIMENS

1. Quality of Steel - The grade of steel contemplated for the entire range of tests shall be Open Hearth Structural Steel for Buildings, conforming to the latest A.S.T.M. Specifications A-9.

Any material containing laminations must be rejected.

2. Preparation for Welding - In order to keep the variables in these tests to a minimum, all joints shall be prepared by non-portable machine tools, usually found in fabricating shops. The allowable tolerance for squareness of welded surfaces shall be within  $\pm 5^\circ$ . To avoid eccentricity of load during the test, specimens must be carefully aligned and rigidly clamped or tack-welded before welding, so that the component parts are in correct alignment upon completion of the welding.

The welding surfaces of all base metal shall be reasonably cleaned of foreign matter, oxide and rust, with a wire brush before welding is attempted. Care shall be taken not to remove mill scale except where its non-removal would be injurious to the weld.

Where multi-layer welding is specified, the surface of the welds shall be carefully cleaned of all adhering scale with a wire brush or by chipping, before superimposing additional layers of weld metal.

3. Position of Specimen During Welding - Specimens shall be welded so that the weld is placed on a horizontal surface, unless otherwise specified on the drawing.

No specimens are to be inclined to facilitate welding.

4. Welding Rods - The welding rods to be used in welding of test specimens shall be:

- (a) Bare wire conforming to the American Welding Society Specifications designated as Class E1A or E1B
- (b) Coated wire or shielded arc process conforming to

5. Preparatory Tacking - All specimens may be clamped or tacked before welding. Location of tacks is suggested on the Specimen Data Sheets by  notation.

6. Welding Arc - The current used shall at all times be within five per cent plus or minus of that specified for each type of specimen. The voltage across the arc shall not exceed 20 volts for plain wire electrodes, nor 25 to 30 volts for coated wire electrodes, depending on the make of electrode used.

7. Gaging Welds - As the purposes of the test program will be furthered by having the weld of a normal size, the tolerances are as specified below. The weld shall at no point fall below the minimum triangle indicated.

Gaging of welds may be done with the set of gages similar to those recommended on pages 32 and 33 of the Report of The Structural Steel Welding Committee.

MAXIMUM AND MINIMUM SIZES OF FILLET WELDS					
Designed Size	Leg Dimension		Throat Dimension		
	Min.	Max.	Minimum	Normal	Maximum
3/8"	3/8"	1/2"	0.265	0.309	0.354
1/2"	1/2"	5/8"	0.354	0.398	0.442
5/8"	5/8"	3/4"	0.442	0.486	0.530
3/4"	3/4"	7/8"	0.530	0.574	0.619

8. Heat Treatment - The specimens shall not be preheated either before or during welding.

The specimens shall not be subjected to heat treatment of any kind after the welding is completed, but shall be allowed to cool normally in the air to room temperature.

9. Identification Marks - Each specimen shall have stamped on it the identification marks as specified on the Specimen Data Sheets.

10. The inspector shall make his report on Form 1001.

D. DESIGN OF TEST SPECIMENS

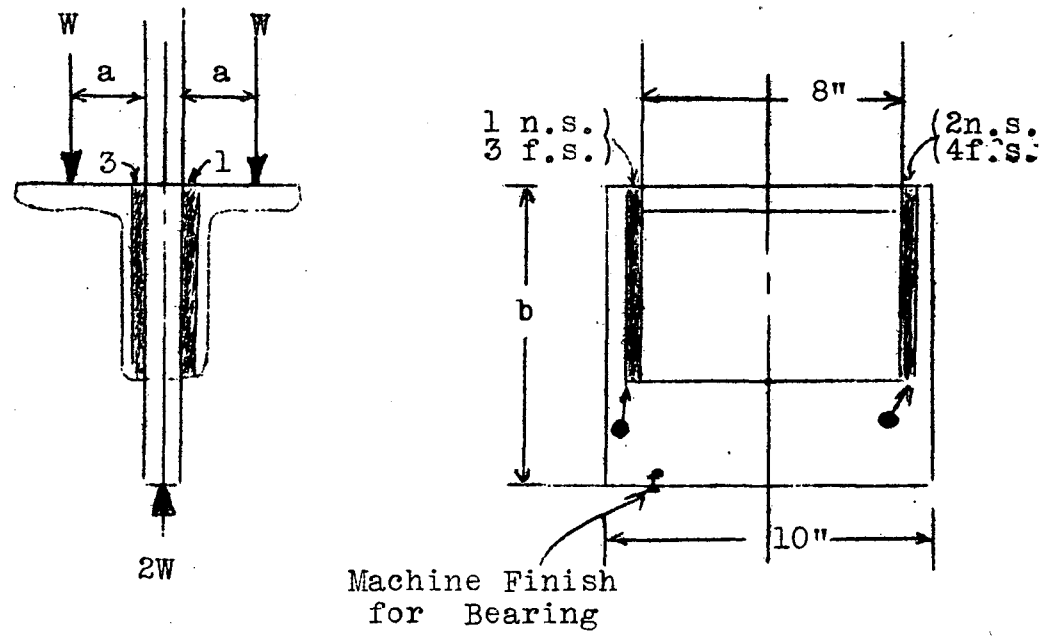

TEST SPECIMEN - SERIES A



SPECIMEN DATA SHEET - SERIES A

Mark No.	Size of Angles		Bar A		WELD DATA						Arn "a"		Total Weight	
			Width	Thick-ness	Size of Fillet	Total Length	Welding Wire		Amps	No. of Layers	No. of Specimens Required	For Data		To Des-truction
							Type	Dia-meter						
A 443	4x4	x1/2	8	3/4"	3/8"	16"	Plain	3/16"	200	1	4*	1.2, 2, 3 in. for all specimens	1.2	136
A 444	4x4	x1/2	8	3/4	1/2	16	∕ Plain	3/16	200	2	2		1.2	68
A 643	6x4	x1/2	10	1-1/4	3/8	24	Plain	3/16	200	1	2 Plain		1.2	228
A 643 C							∕ Coated				2 Coated			
A 644	6x4	x1/2	10	1-1/4	1/2	24	Plain	3/16	200	2	4*		1.2	228
A 654	6x4	x5/8	10	1-1/4	1/2	24	Plain	3/16	200	2	2		1.8	124
A 655	6x4	x5/8	10	1-1/4	5/8	24	∕ Plain	3/16	200	2	2		1.8	124
A 764	7x3-1/2x3/4		10	1-1/4	1/2	28	Plain	3/16	200	2	2 Plain		1.8	275
A 764 C							∕ Coated				2 Coated			
A 765	7x3-1/2x3/4		10	1-1/4	5/8	28	Plain	3/16	200	2	2 Plain		1.8	275
A 765 C							Coated				2 Coated			
A 766	7x3-1/2x3/4		10	1-1/4	3/4	28	Plain	3/16	200	3	2 Plain		1.8	275
A 766 C							∕ Coated				2 Coated			
A 886	8x4	x1	10	1-1/4	3/4	32	∕ Plain	3/16	200	3	2		1.8	171
													1904	

\* (Two of these specimens with line load on outstanding leg  
 (Two of these specimens with load concentrated in center of outstanding leg on a line 1" long

∕ Operator welds two end fillet Control Specimens as given in section B-2a

∕ Operator welds Qualification Specimens as given in section B-2b

General: clamp and tack at points marked before welding

Order of welding: 1, 2, 3, 4

TEST SPECIMENS - SERIES B

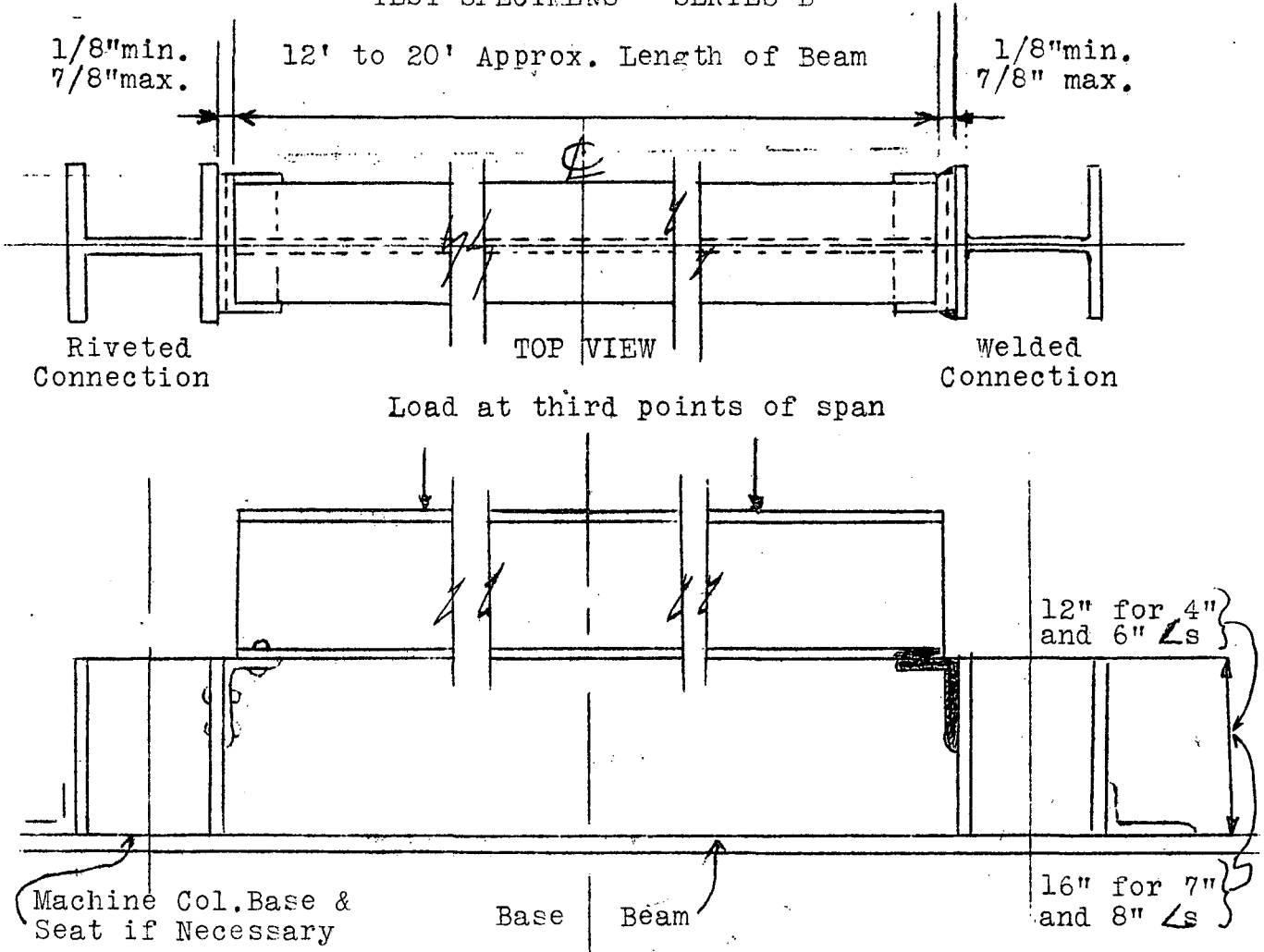

Mark No.	Size of Angles	Welded End Fillet		Riveted End No. of Rivets	End Dia.	Approximate Span
		Total Length	Size			
B 44	4 x 4 x 1/2	To be Decided		2	7/8"	12' 0"
B 46	4 x 4 x 3/4			2	7/8"	12' 0"
B 64	6 x 4 x 1/2			4	7/8"	16' 0"
B 66	6 x 4 x 3/4			4	7/8"	16' 0"
B 84	8 x 4 x 1/2			4	1"	20' 0"
B 88	8 x 4 x 1			4	1"	20' 0"

SPECIMEN DATA SHEET - SERIES C

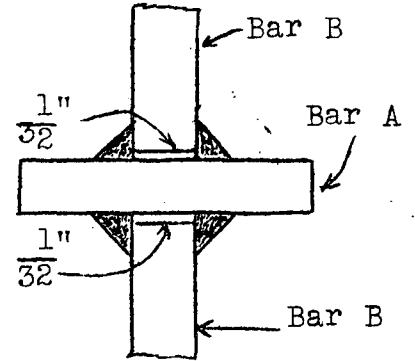
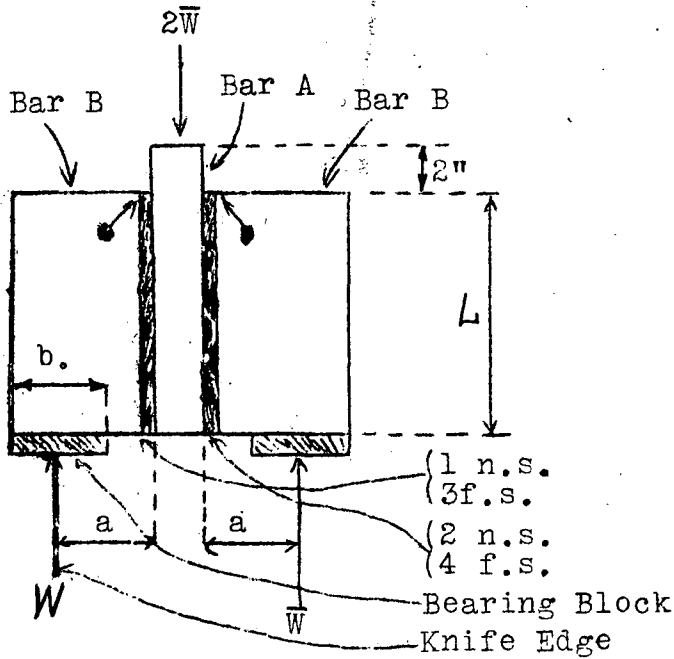

Mark No.	Length L	Arm a	Bearing b	Bar A Size	Bar B Size	Welding Current amps.	Weight of Specimen
C 62	6"	2"	3"	6x 7/8	3-1/2x 5/8	175	20 lb.
C 64	6	4	2	5x 5/8	5 x 5/8	175	18
C 124	12	4	4	8x1-1/2	6 x 7/8	200	77
C 126	12	6	4	8x1-1/4	8 x 5/8	200	75
C 184	18	4	6	12x1-1/2	7 x1-1/4	225	194
C 186	18	6	4	9x1-1/2	8 x1-1/4	225	181
C 246	24	6	6	12x1-7/8	9 x1-1/2	225	354
C 248	24	8	5	12x1-1/2	10-1/2x1-1/2	225	352

Weld size, 3/8" fillet - 3/16" diameter Bare Wire Electrodes

Order of welding - 1, 2, 3, 4.

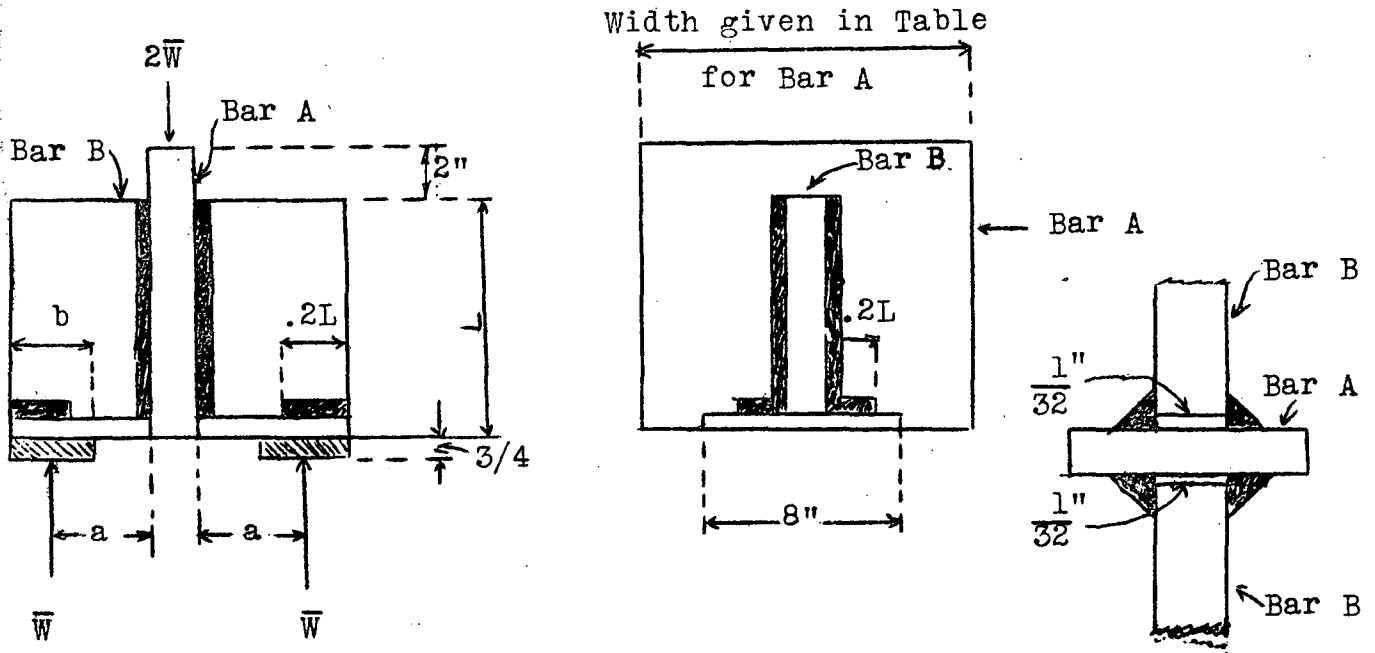

Mark No.	Length L	Arm a	Bearing b	Bar A Size	Bar B Size	Welding Length	Weight of Specimen
D 1	12"	3.2"	1.6"	12x1-1/8	4x1-3/4	67"	119 lb.
D 2	12"	4.8"	2.4"	10x1-1/8	6x 7/8	67	105
D 3	18"	4.8"	2.4	12x1-3/4	6x1-3/4	101	254
D 4	18	6.4	3.2	12x1-1/2	8x1-1/4	101	238
D 5	24	6.4	3.2	14x2	8x1-3/4	135	435
D 6	24	8.0	4.0	14x1-3/4	10x1-1/4	135	394

All Welds 3/8" Fillet - 3/16" diameter Bare Wire Electrode  
Current - 225 amps.

## E. PROCEDURE FOR TESTING

- 11

1. Test of Materials - From each piece of material of different cross-section or mill heat used in the fabrication of test specimens, the laboratory shall machine, finish and test one standard A.S.T.M. tensile specimen (2" gage length) to determine yield point, ultimate strength, elongation in two inches, and contraction of area.

### 2. Laboratory Equipment and Methods of Testing -

(a) Testing Machine - The laboratory engineer of tests shall satisfy himself that the testing machine is in good condition and properly calibrated.

(b) Speed of Testing - The speed of the head of the testing machine up to the yield point shall not exceed 0.05 inches per minute. Above the yield point the speed may be increased if desired.

The machine may be stopped at intervals in order to better observe and record the behavior of, and strain lines on the specimen.

(c) Yield Point and Ultimate Strength - The yield point shall be determined by carefully observing the "drop of the beam". The load shall then be increased until the specimen fails and the ultimate load recorded. A record shall also be made of the load at which anyone of the welds fails or shows unusual behavior.

(d) Whitewash - All specimens shall be coated, prior to testing, with a thin mixture of water and white Portland cement or lime, applied with a soft brush. This will allow strain lines to be observed more easily during the progress of the test.

(e) Reports of Tests - After testing, each broken part shall have its proper identification mark stamped on. The yield point, ultimate strength, and any significant behavior of the specimens shall be recorded, the development of strain lines, particular attention being given to their development on the surface of the weld, should be reported and photographs or sketches of significant cases shall be made.

The nature and location of the fracture must be described, and the fracture carefully inspected, noting depth of fusion or penetration at the root of the weld, dimension of fillet and appearance of weld metal.

(f) Loading - The loading of the outstanding legs of the specimens of Series A shall be a line loading at the eccentricities noted excepting specimens A 443, A 644 which will be loaded in addition with a more concentrated load.

The loading of Series B, C & D shall be as shown on the Specimen Data Sheets.

QUALIFICATION TESTS - WELDING INSPECTION

Shop \_\_\_\_\_ Welder \_\_\_\_\_ Inspector's Name \_\_\_\_\_  
 Arc Welding Machine: A.C. or D.C. \_\_\_\_\_ Make \_\_\_\_\_ Type \_\_\_\_\_ Size \_\_\_\_\_

Date	Specimen No.	Position of Specimen Dur. Welding	Rate of Welding ft./hr.	Arc	Characteristics		Welding Wire		Remarks
				Aver. Amps.	Aver. Volts	Direction of Blow	Trade Name	Diam. in.	

TEST SPECIMENS ----- WELDING INSPECTION

Shop \_\_\_\_\_ Welder \_\_\_\_\_ Inspector's Name \_\_\_\_\_  
 Arc Welding Machine: A.C. or D.C. \_\_\_\_\_ Make \_\_\_\_\_ Type \_\_\_\_\_ Size \_\_\_\_\_

Date	Specimen No.	Position of Specimen Dur. Welding	Rate of Welding ft./hr.	Arc Characteristics			Welding Wire		No. of In. Consumed	Remarks
				Aver. Amps.	Aver. Volts	Direction of Blow	Trade Name	Diam. in.		