

1990

Manual for inspecting bridges for fatigue damage conditions, January 1990, 174p. (Final report)

Ben T. Yen

Ti Huang

Lung-Yang Lai

John W. Fisher

Follow this and additional works at: <http://preserve.lehigh.edu/engr-civil-environmental-fritz-lab-reports>

Recommended Citation

Yen, Ben T.; Huang, Ti; Lai, Lung-Yang; and Fisher, John W., "Manual for inspecting bridges for fatigue damage conditions, January 1990, 174p. (Final report)" (1990). *Fritz Laboratory Reports*. Paper 534.
<http://preserve.lehigh.edu/engr-civil-environmental-fritz-lab-reports/534>

This Technical Report is brought to you for free and open access by the Civil and Environmental Engineering at Lehigh Preserve. It has been accepted for inclusion in Fritz Laboratory Reports by an authorized administrator of Lehigh Preserve. For more information, please contact preserve@lehigh.edu.

REPORT DOCUMENTATION PAGE	1. REPORT NO. FHWA-PA-89-022 + 85-02	2.	3. Recipient's Accession No.
4. Title and Subtitle Manual for Inspecting Bridges for Fatigue Damage Conditions		5. Report Date January 1990	
7. Author(s) Ben T. Yen, TI Huang, Lung-Yang Lai and John W. Fisher		8. Performing Organization Rept. No. Fritz Eng. Laboratory No. 5117	
9. Performing Organization Name and Address Fritz Engineering Laboratory Department of Civil Engineering Lehigh University Bethlehem, Pennsylvania 18015		10. Project/Task/Work Unit No.	
12. Sponsoring Organization Name and Address		11. Contract(C) or Grant(G) No. (C) PennDot Research (G) Project 85-02	
15. Supplementary Notes Prepared in cooperation with U.S. Department of Transportation, Federal Highway Administration. Supersedes Fritz Lab Report 386-15(81)		13. Type of Report & Period Covered Final	
5. Abstract (Limit: 200 words) This report is intended to supplement existing inspection and evaluation manuals and provide engineers with basic information and guidelines for inspecting bridges for fatigue damage. A comprehensive description of the AASHTO fatigue categories of structural details is given in Chapter 2. In Chapters 3 to 6, color photographs and line drawings illustrate the locations and situations which are susceptible to fatigue cracking. Guidelines are provided on where to look and what to look for when inspecting bridges for fatigue damage. Chapters 7 and 8 provide procedures for the estimation of fatigue life and for the evaluation of bridge structure against risk of fatigue failure.		14.	
17. Document Analysis a. Descriptors Fatigue, Fatigue sensitive details, Steel bridges, Concrete bridges, Fatigue life, Fatigue evaluation, Inspection			
b. Identifiers/Open-Ended Terms			
c. COSATI Field/Group			
18. Availability Statement: Unlimited	19. Security Class (This Report) Unclassified	21. No. of Pages 174	
	20. Security Class (This Page) Unclassified	22. Price	

COMMONWEALTH OF PENNSYLVANIA

Department of Transportation Office of Research and Special Studies

Project 85-02: State-of-the-Art for Inspecting
Bridges for Fatigue Damage Condition

Manual For Inspecting Bridges For Fatigue Damage Conditions

By

Ben T. Yen
Ti Huang
Lung-Yang Lai
John W. Fisher

“The work was sponsored by the Pennsylvania Department of Transportation and the U.S. Department of Transportation. Federal Highway Administration.” “The contents of this report reflect the views of the authors who are responsible for the facts and the accuracy of the data presented herein. The contents do not necessarily reflect the official views or policies of either the Federal Highway Administration, U.S. Department of Transportation, or the Commonwealth of Pennsylvania at the time of publication. This report does not constitute a standard, specification, or regulation.”

Lehigh University
Office of Research
Bethlehem, Pennsylvania

January 1990

Department of Civil Engineering Report No. 511-1

TABLE OF CONTENTS

List of Figures	iv
Chapter 1 Introduction	1
1.1 Inspection for Fatigue Damage	1
1.2 Fundamentals of Fatigue	2
1.3 Organization of Manual	5
Chapter 2 AASHTO Categories of Fatigue Strength	6
2.1 Fatigue Strength of Steel Bridge Details	6
2.2 Category A	8
2.3 Category B	8
2.4 Category B'	13
2.5 Category C	18
2.6 Category D	24
2.7 Categories E and E'	24
Chapter 3 Inspection Techniques	38
3.1 Visual Inspection	38
3.2 Signs Suggesting Possible Cracks	39
3.3 Where to Inspect	42
3.4 Documentation of Fatigue Damage	45
Chapter 4 Fatigue Damage at Welded Bridge Details	46
4.1 Residual Stresses, Initial Flaws and Crack Growth	46
4.2 Fatigue Cracks in Main Members	47
4.3 Fatigue Cracks in Members at Connections and Attachments	63
4.4 Fatigue Damage Induced by Out-of-Plane or Transverse Forces and Deflections	72
Chapter 5 Fatigue Damage in Riveted and Bolted Bridge Details	100
5.1 Fatigue Strength of Riveted and Bolted Members and Connections	100
5.2 Fatigue Damage at End Connections	100
5.3 Floorbeams and Cantilever Bucket Connections to Girders	108
5.4 Diaphragms Connections to Girders	112
5.5 Truss Hangers and Eyebars	112
5.6 Tack Welds on Riveted Members	115

Chapter 6	Inspection of Reinforced Concrete and Prestressed Concrete Highway Bridges	120
	6.1 General Discussions	120
	6.2 Inspection of Reinforced Concrete Highway Bridges	121
	6.3 Inspection of Prestressed Concrete Highway Bridges	122
Chapter 7	Estimation of Fatigue Life	124
	7.1 Introduction	124
	7.2 Estimation of Equivalent Stress Range	125
	7.3 Estimation of Fatigue Life	131
	7.4 Procedure for the Estimation of Fatigue Life	134
	7.5 Illustrative Examples	134
Chapter 8	Rating on the Basis of Fatigue Damage	142
	8.1 Introduction	142
	8.2 Load-Rating Based on Brittle Fracture	143
	8.3 Evaluation of Crack Propagation	143
Chapter 9	Recommendations	146
	9.1 Recommended Procedure for Inspecting for Fatigue Damage	146
	9.2 Recommended Procedure for Evaluation	146
	9.3 Discussion	148
Acknowledgement		149
References		150
Appendices		153

FIGURES

- Fig. 1.1 Typical Fatigue Strength Curve
- Fig. 2.1 AASHTO Allowable Fatigue Stress Ranges - Redundant Load Path
- Fig. 2.2 Category A - Base Metal
- Fig. 2.3 Coped, Blocked or Cut-Short Beam Flanges
- Fig. 2.4 Category B - Longitudinal Full Penetration Groove Weld
- Fig. 2.5 Category B - Web-to-Flange Connections and Longitudinal Stiffener
- Fig. 2.6 Category B - Longitudinal Fillet Weld
- Fig. 2.7 Category B - Transverse Full Penetration Groove Weld
- Fig. 2.8 Category B - Transverse Groove Weld, NDI and Ground Flush
- Fig. 2.9 Category B - Transverse Groove Weld, Straight Transition
- Fig. 2.10 Category B - Transverse Groove Weld, Curved Transition
- Fig. 2.11 Category B - Groove-Welded Attachment, Weld Parallel to Stress
- Fig. 2.12 Category B - Groove-Welded Attachment, Weld Transverse to Stress
- Fig. 2.13 Category B - Bolted Connection
- Fig. 2.14 Category B' - Longitudinal Full Penetration Groove Weld, Backing Bar Not Removed
- Fig. 2.15 Category B' - Partial Penetration Groove Weld
- Fig. 2.16 Category B' - Partial Penetration Groove-Welded Connections
- Fig. 2.17 Category B' - Transverse Groove-Welded Connections, A514 or A517 Steel
- Fig. 2.18 Category C - Transverse Stiffeners on Web
- Fig. 2.19 Category C - Transverse Gusset Plate on Web
- Fig. 2.20 Category C - Transversely Groove-Welded Splice, NDI but Not Ground Flush
- Fig. 2.21 Category C - Transversely Groove-Welded Flange Splice, NDI but Not Ground Flush
- Fig. 2.22 Category C - Groove or Fillet Welded Short Attachment

- Fig. 2.23 Category C - Longitudinally Groove-Welded Attachment, Intermediate Transition Radius
- Fig. 2.24 Category C - Transversely Groove-Welded Attachment, Intermediate Transition Radius
- Fig. 2.25 Category C - Transversely Groove-Welded Attachment, Weld Not Ground Flush
- Fig. 2.26 Category C - Fillet Welded Connection (Load Carrying)
- Fig. 2.27 Category C - Fillet Welded Connection (Non Load Carrying)
- Fig. 2.28 Category C - Stud and Channel Shear Connectors
- Fig. 2.29 Category D - Groove or Fillet Welded Attachment, Intermediate Length
- Fig. 2.30 Category D - Welded Gusset Plate, Intermediate Length
- Fig. 2.31 Category D - Welded Gusset Plate on Rolled Shape, Intermediate Length
- Fig. 2.32 Category D - Longitudinally Welded Attachment, Short Transition Radius
- Fig. 2.33 Category D - Transversely Welded Attachment, Short Transition Radius
- Fig. 2.34 Category D - Transversely Welded Attachment, Unequal Plate Thickness
- Fig. 2.35 Category D - Fillet Welded Attachment, Transition Radius 2" or More
- Fig. 2.36 Category D - Riveted Connections
- Fig. 2.37 Category E or E' - Ends of Welded Cover Plate
- Fig. 2.38 Category E or E' - Ends of Wider Cover Plate
- Fig. 2.39 Category E or E' - Longitudinally Welded Attachment
- Fig. 2.40 Category E or E' - Longitudinally Welded Attachment (Lap Joint)
- Fig. 2.41 Category E - Welded Attachment, Very Short Transition Radius
- Fig. 2.42 Category E - Longitudinally Welded Attachment, Any Transition Radius, Ends Not Ground Smooth
- Fig. 2.43 Category E - Groove-Welded Attachment, Transverse Load
- Fig. 2.44 Category E - Fillet Welded Attachment, Transverse Load
- Fig. 2.45 Category E - Intermittent Fillet Welds
- Fig. 3.1 Oxide Film along End of Welded Cover Plate
- Fig. 3.2 Discoloring of Paint Film

- Fig. 3.3 Oxide Particles due to Rubbing of Parts
- Fig. 3.4 Oxide Particles at Rivet
- Fig. 3.5 “Bleeding” at Invisible Crack
- Fig. 4.1 Cracked Flange at Cover Plate
- Fig. 4.2 Crack Propagating Through Welds into Web Plate
- Fig. 4.3 Crack at Welded End of Cover Plate
- Fig. 4.4 Crack at Ends of Welded Cover Plates - Schematic
- Fig. 4.5 Crack at Electroslag Groove Weld of Flange
- Fig. 4.6 Crack in Butt-Welded Longitudinal Stiffener
- Fig. 4.7 Intersecting Members with Flange Splice Plate Passing through Web
- Fig. 4.8 Crack in Box Girder Web at Penetrating Flange Splice Plate
- Fig. 4.9 Crack Revealed by Dye Penetrant
- Fig. 4.10 Welded Insert Plate in Web
- Fig. 4.11 Patch Plate on Girder Web along Flange Angle
- Fig. 4.12 Splice Plate on Tension Member
- Fig. 4.13 Crack Forming at Weld-Filled Holes
- Fig. 4.14 Cracks Originating from Back-up Bars
- Fig. 4.15 Cut Short, Coped and Blocked Beam Flanges
- Fig. 4.16 Cracking from Coped Flanges of Rolled Members
- Fig. 4.17 Crack in Floor Beam Web Cut-short Flange Plate
- Fig. 4.18 Cracking at Cross Beam to Column Connections
- Fig. 4.19 Fatigue Crack at End of Box Pier Cap at Bent
- Fig. 4.20 Crack at End of Lateral Connectionjs Plate Weld on Flange Tip
- Fig. 4.21 Intersecting Welds at Gusset-Stiffener-Web Intersection-Schematic
- Fig. 4.22 Crack in Girder Web at Floor Beam Connection Plate-Schematic
- Fig. 4.23 Crack in Girder Web at Floor Beam Bracket Connection-Schematic
- Fig. 4.24 Fatigue Crack in Girder Web at Floorbeam Connection Plate
- Fig. 4.25 Crack in Girder Web at X-diaphragm Connection

- Fig. 4.26 Crack in Girder Web at Beam Type Diaphragm
- Fig. 4.27 Crack in Web near Support
- Fig. 4.28 Crack in Girder Web at Bottom of Floorbeam Connection (View from Outside)
- Fig. 4.29 Crack at Unattached Lower End of Diaphragm Connection Plate in Skewed Bridge
- Fig. 4.30 Fatigue Crack in Weld between Flange and Diaphragm Connection Plate
- Fig. 4.31 Crack in Diaphragm Connection Plate at Gusset
- Fig. 4.32 K-Diaphragm in Box Girder
- Fig. 4.33 Crack in Web at End of Diaphragm Connection Plate
- Fig. 4.34 Partial Depth Diaphragm inside Tie Girder
- Fig. 4.35 Fatigue Crack at End of Diaphragm Plate
- Fig. 4.36 Fatigue Cracks in Diaphragm Weld and in Flange-to-Web Weld
- Fig. 4.37 Lateral Bracing Gusset at Floor Beam Connection Plate
- Fig. 4.38 Fatigue Crack at Lateral Bracing Gusset Plate Gap
- Fig. 4.39 Crack in Gap between Lateral Bracing Gusset and Floor Beam Connection Plate
- Fig. 4.40 Crack in Weld at End of Lateral Bracing Gusset
- Fig. 4.41 Floor Beam-Cantilever Bracket Tie Plate not Connected to Girder Top Flange -- Schematic
- Fig., 4.42 Fatigue Cracks in Floor Beam Web at Connection to Girder
- Fig. 4.43 Crack in Web of Cantilever Bracket
- Fig. 4.44 Crack in Floor Beam Web at Connection to Girder
- Fig. 4.45 Crack in Web of Floor Beam and in Floor Beam Connection Plate
- Fig. 4.46 Schematic of Welded Pin Plates
- Fig. 4.47 Broken Hanger Plate
- Fig. 5.1 Fatigue Test Date for Full Scale Riveted Bridge Members
- Fig. 5.2 Cracking of Rivet at Stringer-Floor Beam Connection
- Fig. 5.3 Missing Bolt at End of Angle

- Fig. 5.4 Fatigue Crack at End of Connection Angle
- Fig. 5.5 Crack in Longitudinal Girder-Cross Girder Connection Angle
- Fig. 5.6 Cross-Sectional View of Connection Angle with Fatigue Cracks
- Fig. 5.7 Fatigue Cracks in Web of Riveted Girder at End of Floor Beam
- Fig. 5.8 Crack in Floor Beam Web at Riveted Connection to Girder
- Fig. 5.9 Bleeding from Rivet Suggesting Cracking Underneath Rivet Head
- Fig. 5.10 Cracking of Floor Beam Web at Connection to Tie Girder
- Fig. 5.11 Crack in Tie Plate Connected to Girder Flange
- Fig. 5.12 Vertical Crack in Diaphragm Connection Angle
- Fig. 5.13 Fatigue Cracks in Truss Hanger
- Fig. 5.14 Link Plate and Anchoring Eyebar at End of Suspension Bridge
- Fig. 5.15 Crack at Tack Weld between Hanger Gusset Plate and Truss Top Chord
- Fig. 5.16 Lower Panel Point of Truss with Crack at Tack Welds
-
- Fig. 7.1 Typical Strain-time Record from a simply supported Bridge Girder caused by one single truck
- Fig. 7.2 Typical Stress-range Histogram
- Fig. 7.3 Estimation of total Fatigue Life and Remaining Fatigue Life
- Fig. 7.4 ADTT Variation with Time
- Fig. 7.5 Field Measured Stress Range Histogram for Example 1
- Fig. 7.6 ADTT Record for Example 1
- Fig. 7.7 Estimation of Remaining Fatigue Life for Example 1
- Fig. 7.8 Bridge Geometry for Example 2
- Fig. 7.9 Longitudinal Location of Truck for Producing Maximum Stress Range for Example 2
- Fig. 7.10 Transverse Location of Truck for Computing Stress Range in Exterior Girders for Example 2
- Fig. 7.11 Composite Cross section of the Exterior Girder for Example 2

CHAPTER 1. INTRODUCTION

1.1 Inspection for Fatigue Damage

The primary purpose of this manual is to provide bridge inspectors and engineers with information regarding fatigue damage in highway bridge structures. An earlier report, "Inspecting Steel Bridges for Fatigue Damage",⁽¹⁾ prepared in 1981 under the support of Pennsylvania Department of Transportation and the U.S. Federal Highway Administration, contains valuable information for inspecting steel bridges. Since then, substantial research has been conducted,^(2,3,4,5,) and extensive additional field data have been accumulated.^(6,7) The design criteria on fatigue have also been modified.^(3,8) This report has been prepared to replace the earlier one.

This new manual provides the most up-to-date information and recommendations on the inspection of bridge structures for fatigue damages. It summarizes the basic information on fatigue strength of bridge details, incorporates recent research findings, and contains additional examples and illustrations of fatigue damages in welded, bolted and riveted steel highway bridge structures. In addition, the scope of this report has been expanded to include available information regarding reinforced concrete and prestressed concrete bridge structures.

Many manuals and publications are currently available providing guidelines and recommendations for inspecting and rating of bridge structures. These include the FHWA Bridge Inspector's Training Manual⁽⁹⁾, AASHTO Manual for Maintenance Inspection of Bridges⁽¹⁰⁾, (currently being revised), OECD Bridge Inspection⁽¹¹⁾, the FHWA Manual on Inspection of Fracture Critical Bridge Members⁽¹²⁾, and the PennDOT Guidelines for Fatigue and Fracture Safety Inspection of Bridges⁽¹³⁾. This present manual is intended to provide concise comments and illustrations regarding fatigue damage in steel as well as concrete bridge structures.

It must be emphasized that fundamental differences exist between the evaluation of an existing bridge structure and the design of a new one, even though the same fatigue strength information is used in both cases. The AASHTO Bridge Specifications⁽⁸⁾ provides this information in the form of allowable stress range limitations for different categories of structural details. For design, these allowable stress range values are used directly as limitations for calculated stresses caused by live load and impact. For evaluation, these same stress range values are used to determine whether the structure can continue to support the prevailing traffic over a specified period of time (life estimation), or whether a load limitation needs to be imposed on a bridge structure in order to maintain service (load rating). While design computations usually incorporate simplifying assumptions regarding the nature of the structure and load application, in evaluation, attention must be given to the actual structural conditions, as revealed by inspection, and to the actual (three-dimensional) behavior of the structure under load. A thorough understanding of the behavior of a bridge is very important to the inspection and evaluation of bridges.

1.2 Fundamentals of Fatigue

Fatigue is the phenomenon of material failure by repeated applications of loads which, when induced only a single time or infrequently, would cause no undesirable effects or failure.⁽¹⁴⁾ The phenomenon of fatigue is of particular importance in bridge engineering on account of the expected large number of applications of live load over the service life of the bridge structure. An average daily truck traffic count (ADTT) of a thousand over a bridge would introduce 3.65 million load cycles to the bridge in ten years and many more stress cycles at the details of the structure.

The primary factors affecting the fatigue life of bridge details are the magnitude of stress ranges (live load and impact stresses), the number of application (cycles) of these

stresses, and the type and quality of the structural details.⁽¹⁵⁾ The stress ranges are either those due to the primary action of the structural member, such as bending of girders, or due to so called "secondary effects", such as out-of-plane deformation of structural members. Very often, these secondary effects are responsible for high magnitudes of stress ranges which cause fatigue damages to develop at bridge details.

The fatigue characteristic of a structural detail is most commonly represented by an S-N curve, which depicts the relationship between the magnitude of stress range, S_R , and the number, N , of applications of this stress range causing fatigue failure (Fig. 1.1). Except for very low magnitudes of stress range, the fatigue life is inversely related to the stress range. Stress cycles of very low magnitude may be repeated indefinitely without causing fatigue. The limiting stress range which does not cause fatigue cracking is called the fatigue limit.

The type and quality of structural details have an important influence on the fatigue life. Fatigue damages generally occur at connections, locations of abrupt dimensional changes, and surface or internal flaws; all are structural details with local stress concentration. In general, welded bridge details are more susceptible to fatigue failure than riveted or bolted ones. Flaws or defects in welded joints are less tolerant to repeated stresses and crack growth. In addition, the continuity of material at welded connections enables cracks to propagate through the connected parts. In contrast, at riveted or bolted details, cracks do not automatically grow from one component to the adjacent components.

Fatigue cracks, if not controlled, can lead to serious reduction of member area or to sudden fracture of the member. The material fracture toughness controls the size of the largest crack that can be tolerated before sudden brittle fracture occurs in a structural member or component. This limiting crack size is also dependent upon the type of

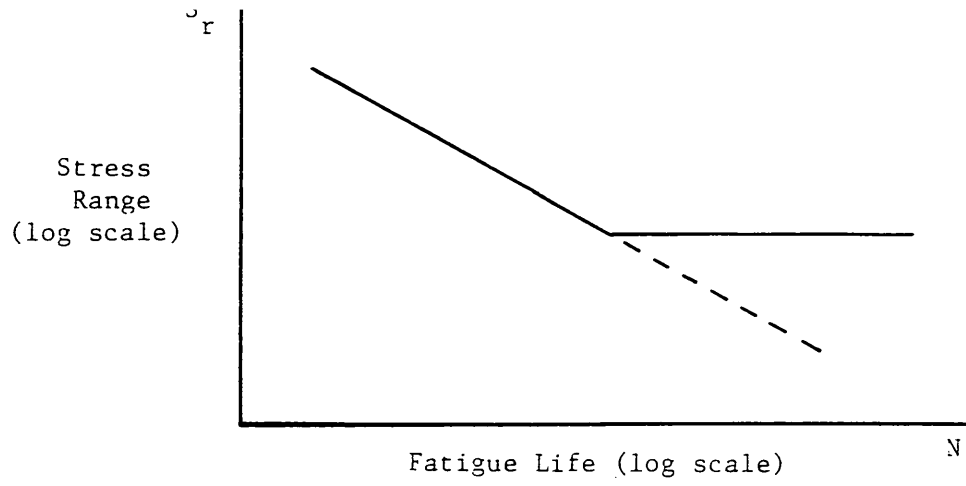

Fig. 1.1 Typical Fatigue Strength Curve

structural detail, the maximum tensile stress and the crack direction.⁽¹⁷⁾ Cracks parallel to the direction of primary tensile stresses in a member are usually not imminently serious. However, those cracks perpendicular to the direction of tensile stresses are likely to grow and become critical. Good understanding of the behavior of the bridge and the damaged details is essential for evaluation.

1.3 Organization of Manual

This manual is intended to provide engineers with basic information on inspecting bridges for fatigue damage.

A comprehensive description of the AASHTO categories of structural details with respect to their fatigue strength is given in Chapter 2. Chapter 3 provides a brief description of the technique for the inspection of bridge structures for fatigue damage. Examples of fatigue damage in welded, riveted and bolted bridge structures, including some explanation of the cause and development of potential cracks, are given in Chapters 4 and 5. Chapter 6 summarizes the current knowledge on fatigue of reinforced concrete and prestressed concrete bridge structures.

Chapter 7 presents a rational procedure for the estimation of fatigue life of undamaged structures. Chapter 8 describes briefly the criteria for the evaluation of member strengths with respect to fatigue crack growth and brittle fracture. Chapter 9 provides general discussions and recommendations.

CHAPTER 2. AASHTO CATEGORIES OF FATIGUE STRENGTHS

2.1 Fatigue Strength of Steel Bridge Details

For the purpose of design against risks of fatigue failure of steel bridge members, AASHTO Specifications⁽⁸⁾ classify common steel bridge structural details into a number of categories. The most recently adopted provisions, first approved in 1987,⁽⁸⁾ incorporate the latest refinements on the stress-cycle (S-N) relationship. These newly revised provisions are reproduced in Appendix A. The allowable stress ranges for the seven structural detail categories are abstracted and listed in Table A1. The corresponding S-N curves are shown in Fig. 2.1. For a specified or anticipated fatigue life, details of higher fatigue strength categories are allowed higher stress ranges (live load and impact stresses) than the lower category details.

These categories of fatigue strength of bridge details are also used for the estimation of fatigue life of the details in existing bridges. If the actual magnitudes of stress ranges are known at a bridge detail, the anticipated total life in number of live load stress cycles can be approximated from the appropriate S-N curve. Because live load stress ranges at a detail are of different magnitudes due to different vehicular loads, the estimation of remaining life of the detail requires consideration of the actual variable stress range spectrum and is more complicated than the design of the detail. In any event, the knowledge of fatigue strength of the detail categories is essential.

Schematics of bridge and structural details and the fatigue strength categories are sketched in Figs. 2.2 to 2.45. These details are presented in descending order of the fatigue strength, from Category A to categories E and E'. In all sketches, the locations of potential fatigue cracks are indicated by the positions of the arrows, which show the direction of the controlling tensile stresses. Fatigue cracks generally propagate perpendicular to the stress arrows.

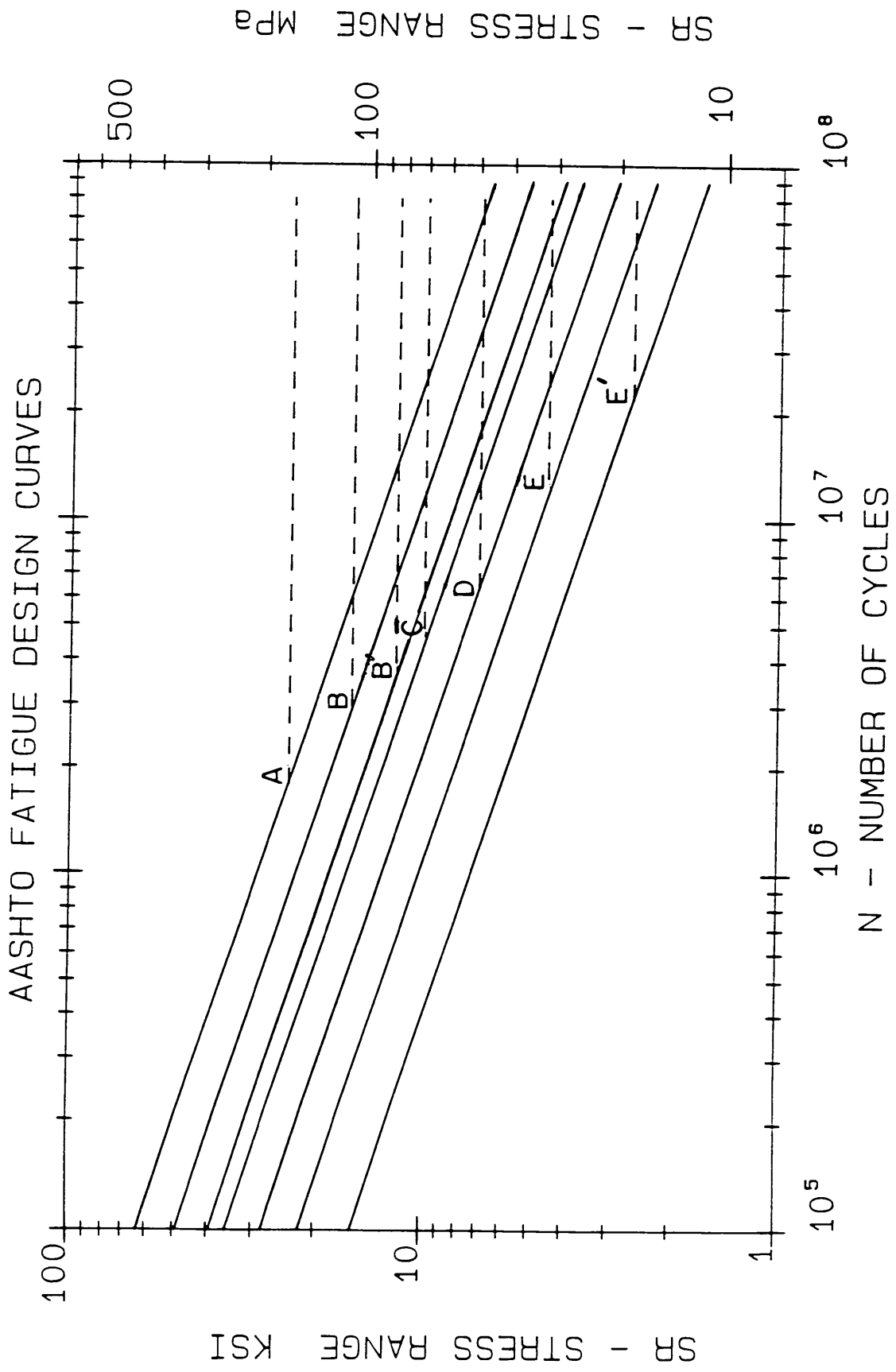

Fig. 2.1 AASHTO Allowable Fatigue Stress Ranges - Redundant Load Path

2.2 Category A

The Category A fatigue strength detail refers to "base metal" or plain material with rolled or cleaned surfaces away from welded, riveted or bolted connections (Fig. 2.2). This category reflects the most ideal condition and provides the highest fatigue strength of structural members. Fatigue cracks are unlikely to develop in these areas. At the edges of flanges and plates where sharp indentations may exist resulting from handling or fabrication, fatigue cracks could eventually develop. At coped, blocked or cut short flanges of beams (Fig. 2.3), the fatigue strength is lower than Category A, and depends on the geometry and smoothness of the edges at the re-entrant corner.

It is not necessary to examine the base metal regions for fatigue cracks unless the regions are susceptible to distortion, because cracks usually develop at lower fatigue strength categories.

2.3 Category B

Category B includes a number of welded structural details and high strength bolted joints.

1. Longitudinal continuous welds in built-up plates and shapes (the welds are parallel to the direction of the member):
 - Full penetration groove welds with backing bars removed (Fig. 2.4)
 - Full penetration groove welded or fillet welded web-to-flange connections in built-up plate girder (Fig. 2.5).
 - Continuous fillet welds at longitudinal stiffeners (Fig. 2.5), except at the ends of the welds.
 - Fillet welds joining cover plates to girder flanges (Fig. 2.6), except at the ends of the welds.

The fatigue strength of these details is primarily governed by the subsurface discontinuities or flaws in the welds or surface notches.

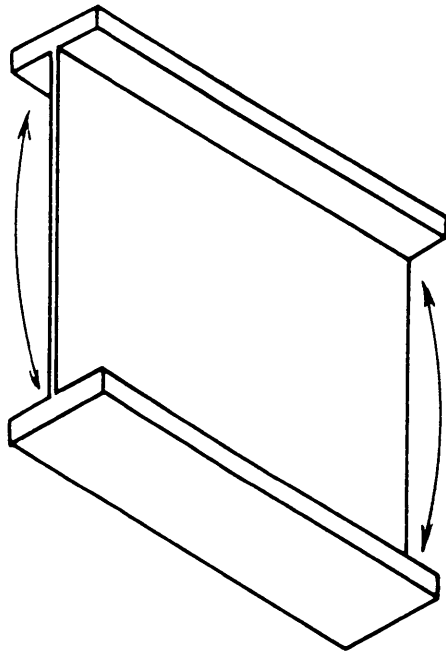
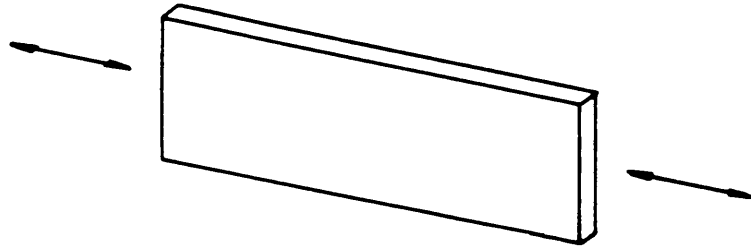
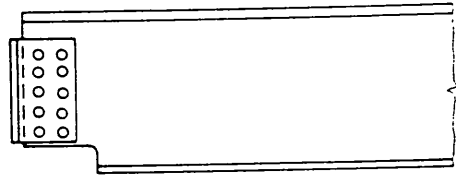
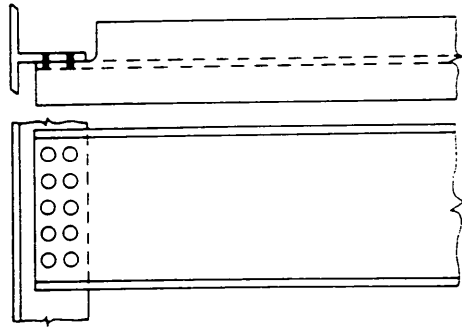

Fig. 2.2. Category A - Base Metal



(a) Coped Beam Flange



(b) Blocked Beam Flanges

Fig. 2.3. Coped, Blocked or Cut-Short Flanges

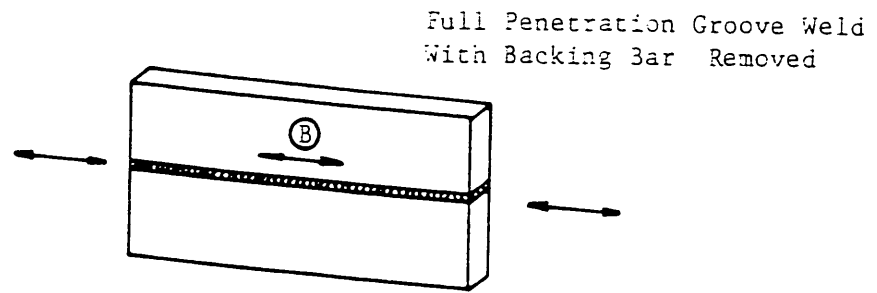

Fig. 2.4. Category B - Longitudinal Full Penetration Groove Weld

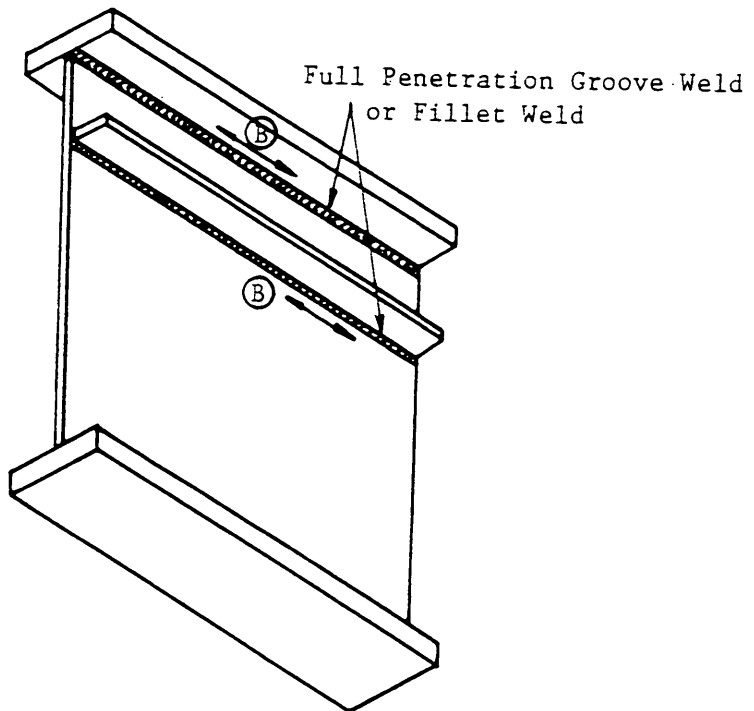

Fig. 2.5. Category B - Web-to-Flange Connections and Longitudinal Stiffener

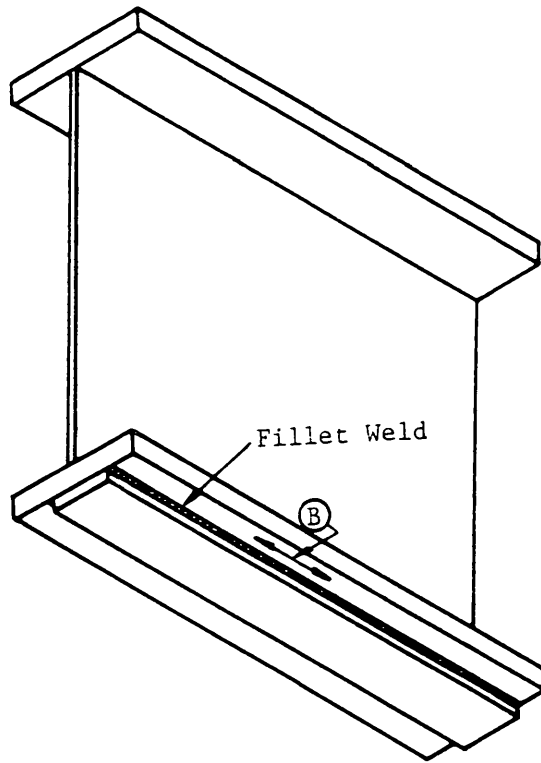

Fig. 2.6. Category B - Longitudinal Fillet Weld

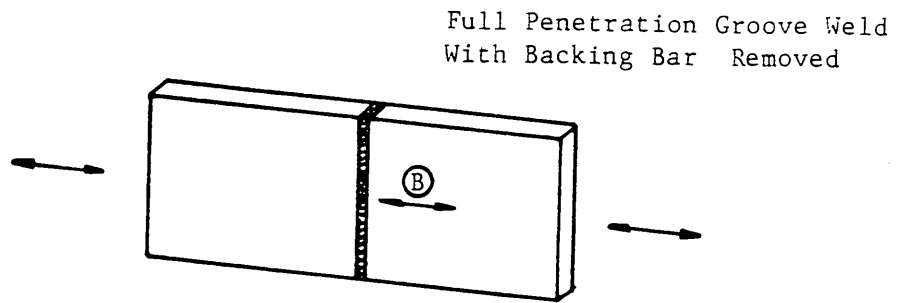

Fig. 2.7. Category B - Transverse Full Penetration Groove Weld

2. Transverse full penetration groove welds with weld reinforcement ground smooth and weld soundness established by non-destructive inspection (NDI):
 - Butt jointed plates with uniform cross section (Fig. 2.7).
 - Flange and web butt joints with the same cross section on both sides (Fig. 2.8).
 - Butt joints with a straight transition in width or thickness, slope of transition not steeper than 1 to 2.5, and with base metal other than A514 or A517 (Fig. 2.9).
 - Butt joints with a curved transition in width, curve radius not less than 24 in. (Fig. 2.10).
3. Groove welded attachments, with a transition radius not less than 24 in.
 - Full or partial penetration groove weld parallel to the direction of stress in the member and the end welds ground smooth (Fig. 2.11).
 - Full penetration groove weld transverse to the direction of stress of the attachment, plates of equal thickness, weld reinforcement removed and weld soundness transverse to direction of stress established by NDI. (Fig. 2.12).
4. High strength bolted connections (Fig. 2.13)
 - Gross section away from bolt holes of slip-resistant, friction-type connections.
 - Net section through bolt holes of bearing-type connections with tightened bolts.

2.4 Category B'

Category B' is a new (1987) sub-category including details similar to those of Category B, but more sensitive to fatigue.

1. Longitudinal continuous welds in built-up plates and shapes
 - Full penetration groove welds, backing bars not removed (Fig. 2.4).
 - Partial penetration groove welds in plates (Fig. 2.15).
 - Partial penetration groove welds joining girder flange and web or longitudinal stiffener to web (Fig. 2.16).

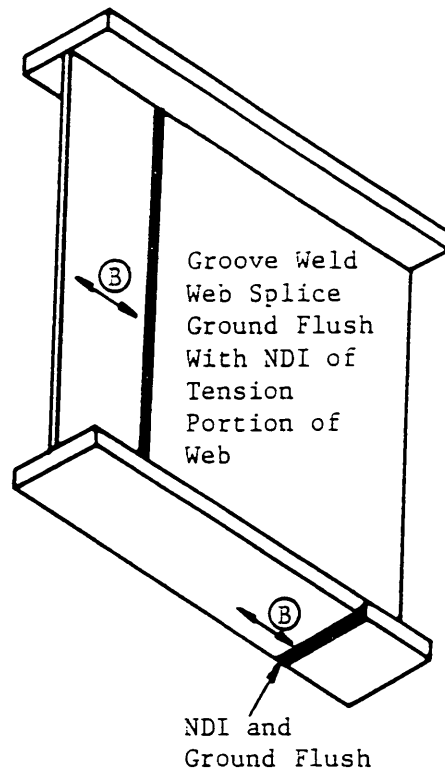

Fig. 2.8. Category B - Traverse Groove Weld, NDI and Ground Flush

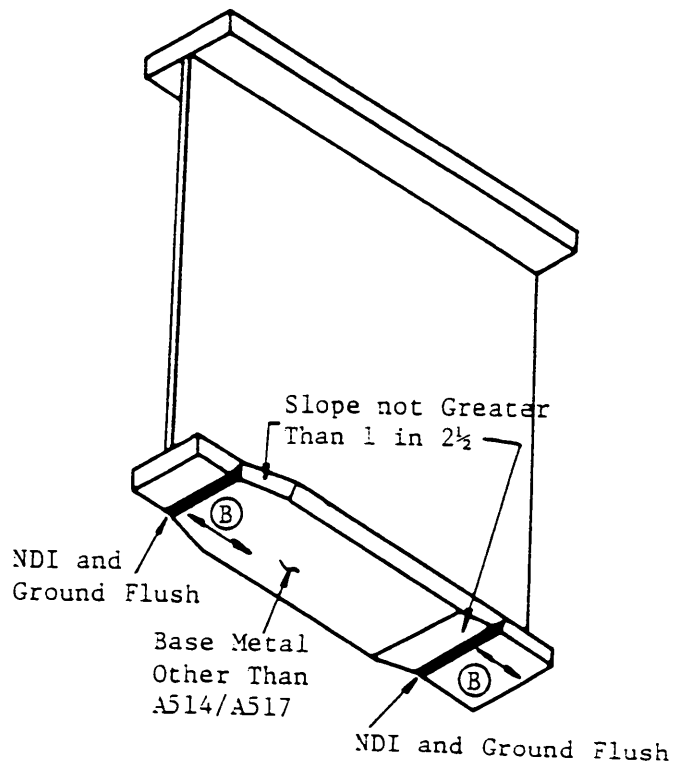

Fig. 2.9. Category B - Traverse Groove Weld, Straight Transition

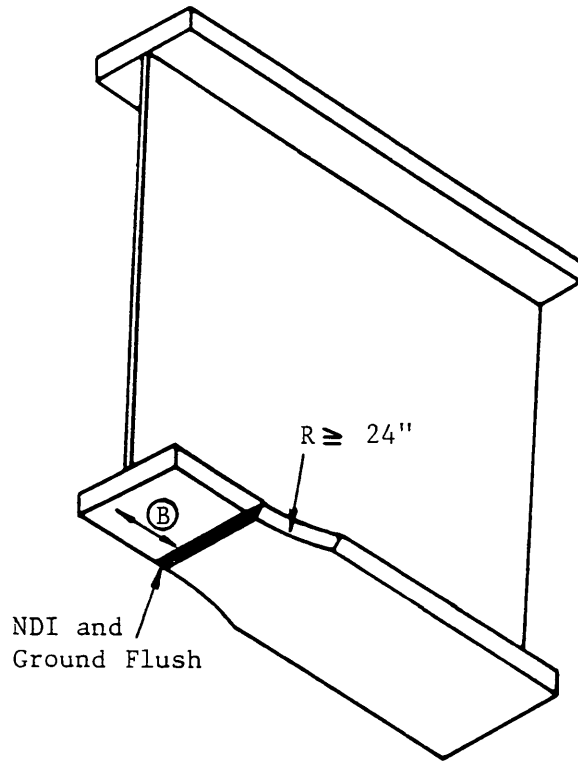

Fig. 2.10. Category B - Transverse Groove Weld, Curved Transition

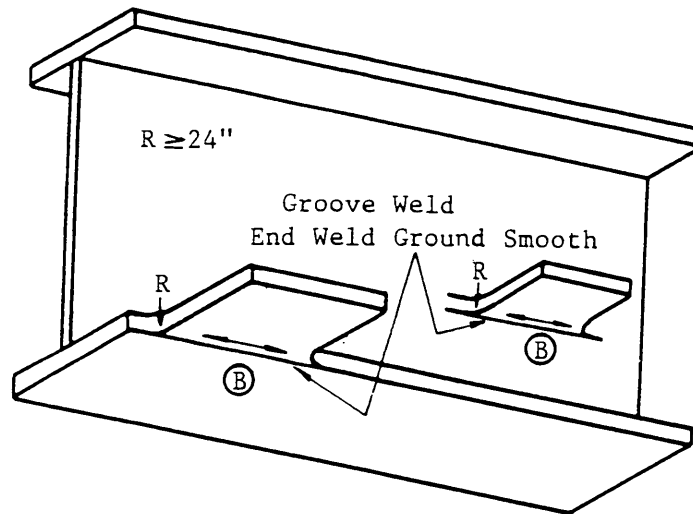

Fig. 2.11. Category B - Groove-Welded Attachment, Weld Parallel to Stress

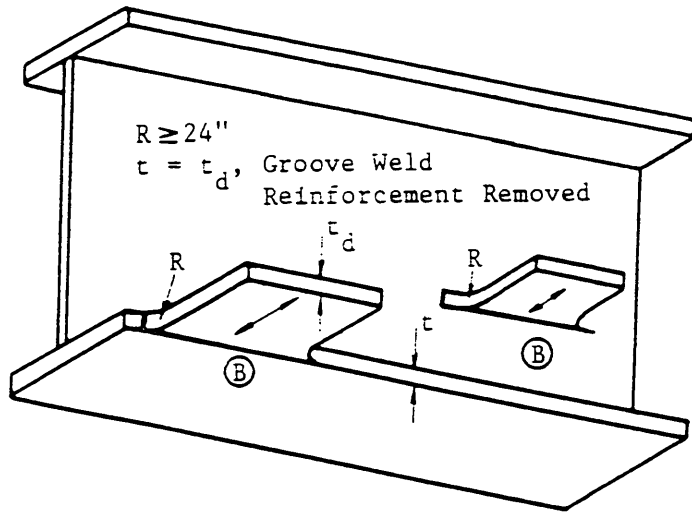

Fig. 2.12. Category B - Groove-Welded Attachment, Weld Transverse to Stress

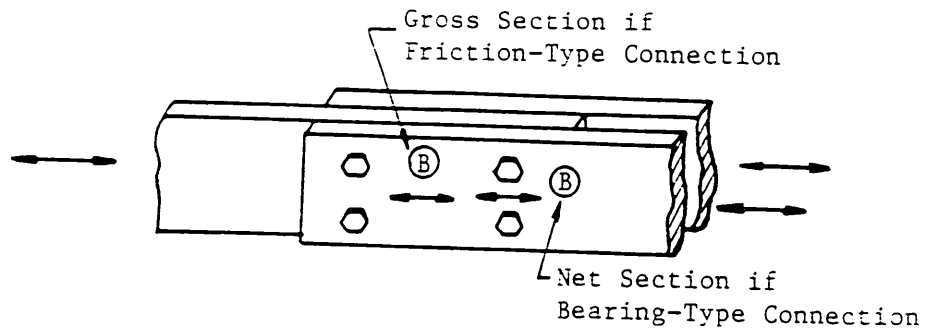

Fig. 2.13. Category B - Bolted Connection

Full Penetration Groove Weld,
Backing Bar not Removed

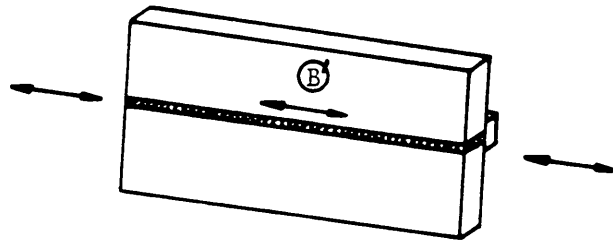

Fig. 2.14. Category B' - Longitudinal Full Penetration Groove Weld
Backing Bar Not Removed

Partial Penetration Groove Weld

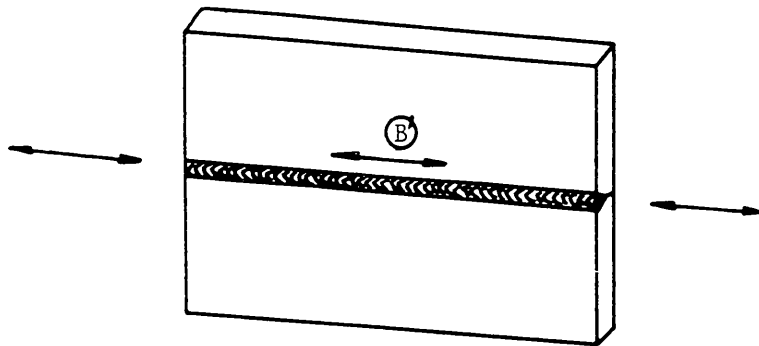

Fig. 2.15. Category B' - Partial Penetration Groove Weld

2. Transverse full penetration groove welds with reinforcement ground smooth to provide straight transition in width or thickness, slopes of transition not steeper than 1 to 2.5, and base metal being A514 or A517 (Fig. 2.17).

(Note this detail is identical to that in Fig. 2.9, except for the base metal).

2.5 Category C

Category C details include transverse stiffeners, very short attachments, and transverse groove welds with reinforcements not removed.

1. Base metal at welds connecting transverse stiffeners or vertical gusset plates to connection and gusset plates to girder webs or flanges (Fig. 2.18, 2.19).
2. Transverse full penetration groove welds, weld reinforcements not removed, but with weld soundness established by NDI.
 - Flange and web butt splices with the same cross section on both side (Fig. 2.20).
 - Butt joints with width or thickness transition, slope of straight transition not greater than 1 to 2.5. (Fig. 2.21).

(Notice that these are similar to Figs. 2.8 and 2.9 except that the weld reinforcements are not removed).

3. Groove or fillet-welded horizontal gusset or attachment, the length of which (in the direction of the main member) is less than 2 in. (Fig. 2.22).
4. Groove welded attachments with transition radius between 6 in. and 24 in.
 - Full or partial penetration groove weld parallel to the direction of stress in the member with the end welds ground smooth. (Fig. 2.23).
 - Full penetration weld perpendicular to the direction of stress in the attachment, plates of equal thickness, and weld soundness transverse to direction of stress established by NDI. (Figs. 2.24, 2.25).

(Note the above are the same Figs. 2.11 and 2.12 except for the smaller transition radius).

5. Intersecting plates connected by fillet welds with the discontinuous plate not more than 0.5 in. thick (Figs. 2.26, 2.27).

If the plate thickness is more than 0.5 in. or if subsize weld is used, the fatigue strength can be substantially reduced. See Appendix A for information on the strength reduction.

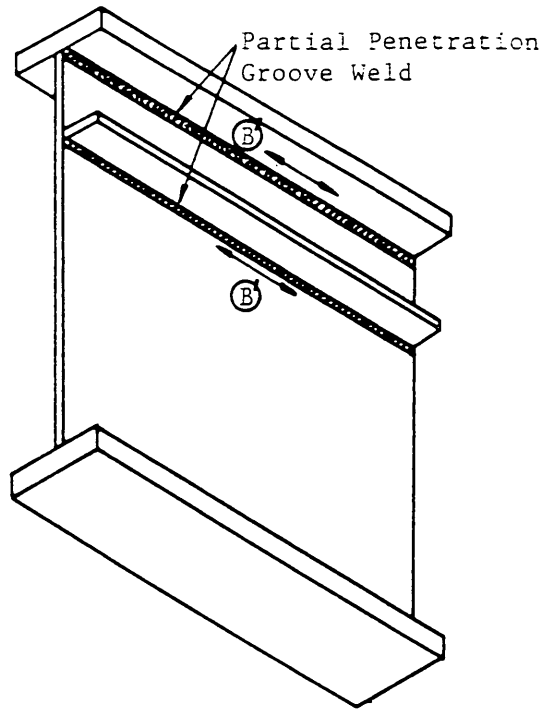

Fig. 2.16. Category B' - Partial Penetration Groove Weld Connections

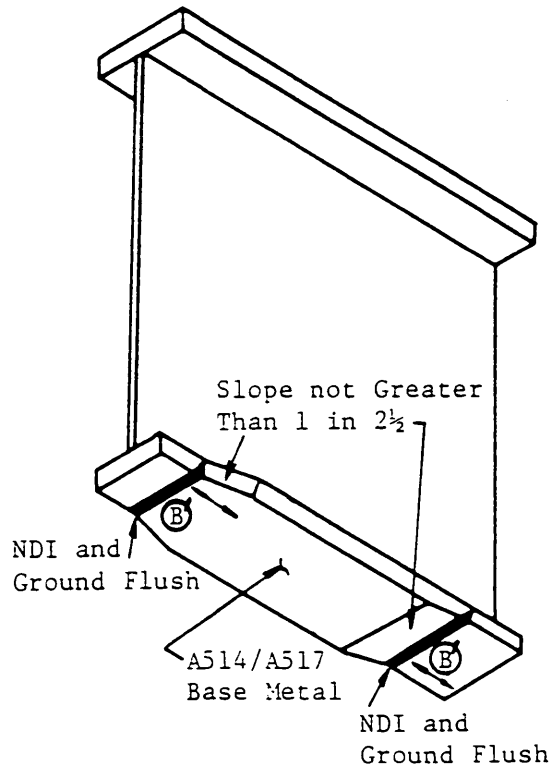

Fig. 2.17. Category B' - Transverse Groove Welded Connections, A514 or A517 Steel

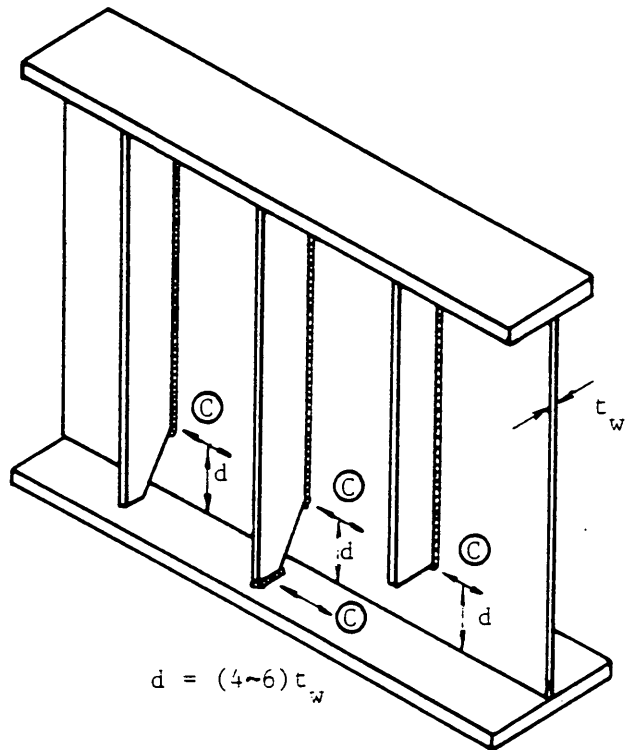

Fig. 2.18. Category C - Transverse Stiffeners on Web

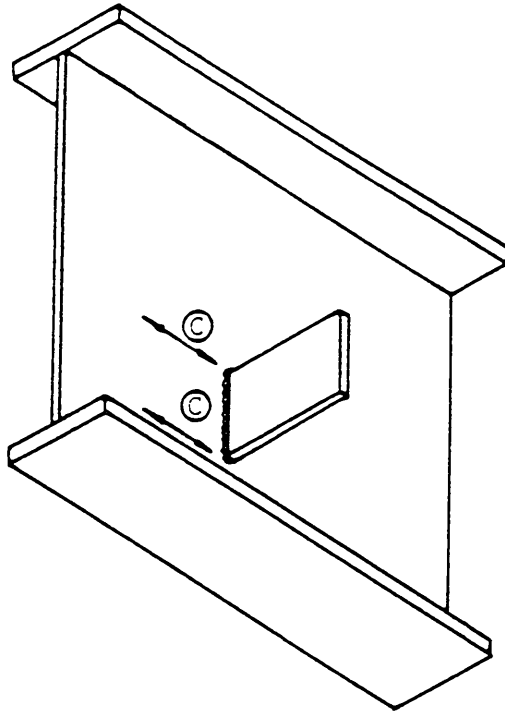

Fig. 2.19. Category C - Transverse Gusset Plate on Web

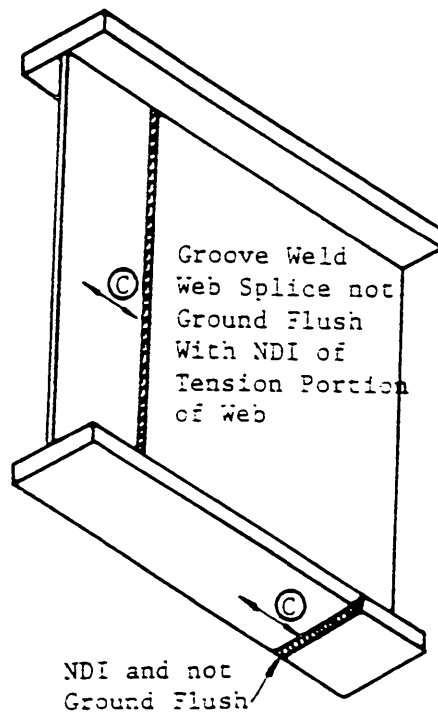

Fig. 2.20. Category C - Transverse Groove Welded Splice,
NDI but Not Ground Flush

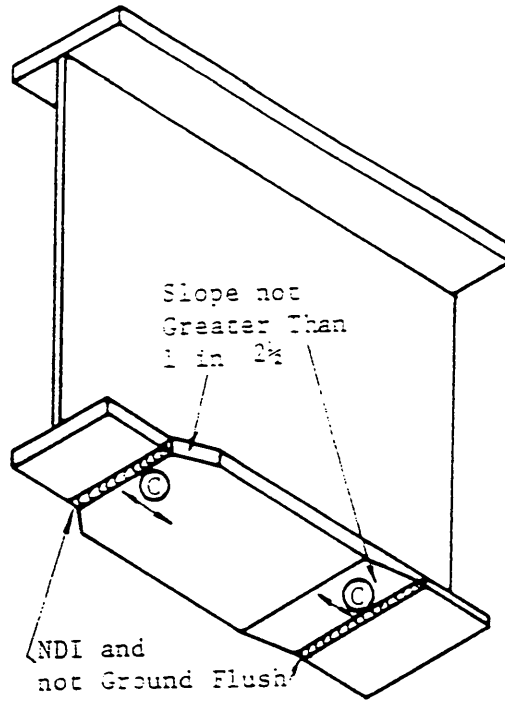

Fig. 2.21. Category C - Transverse Groove Welded Flange Splice, NDI but Not Ground Flush

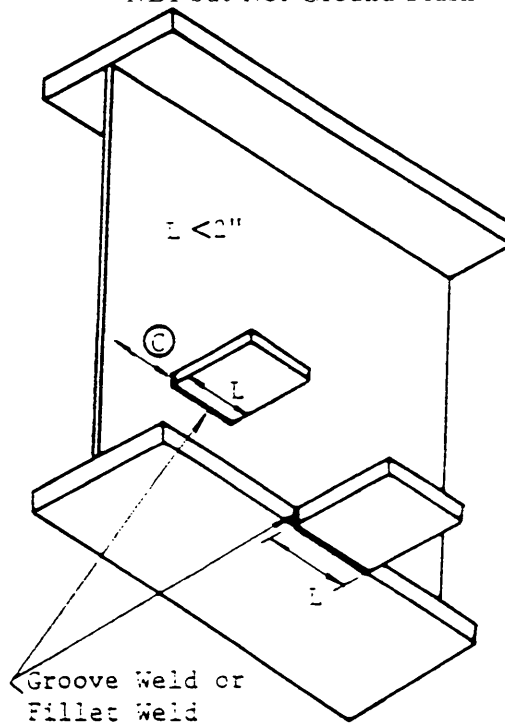

Fig. 2.22. Category C - Groove or Fillet Welded Short Attachment

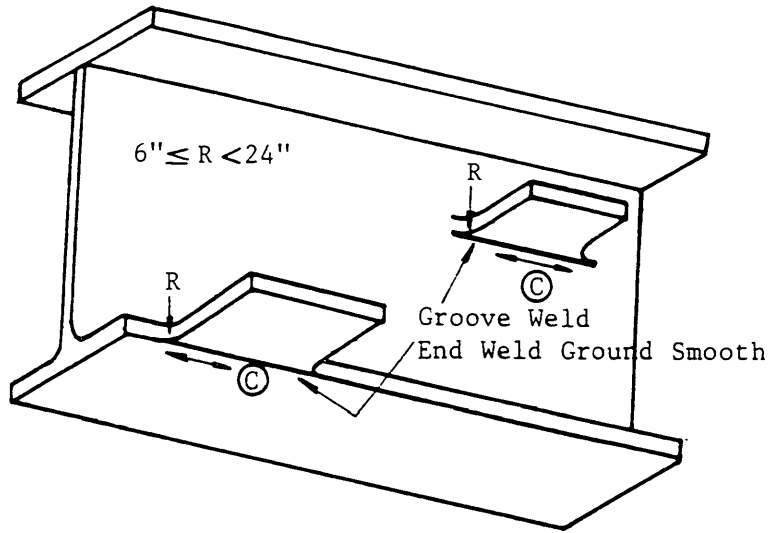

Fig. 2.23. Category C - Longitudinal Groove Welded Attachment
Intermediate Transition Radius

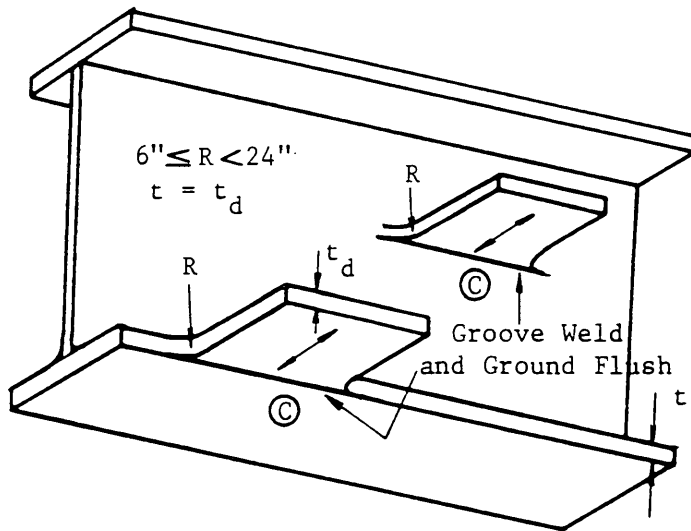

Fig. 2.24. Category C - Transverse Groove Welded Attachment,
Intermediate Transition Radius

6. Shear Connectors

- Stud shear connectors (Fig. 2.28).
- Channel shaped shear connectors with the length of weld along the longitudinal edge of channel flange not more than 2 in. long. (Fig. 2.28).

2.6 Category D

Category D details include welded short attachments, welded connections with sharp transition curves, and riveted joints.

1. Welded attachments with groove or fillet weld in the direction of the main member between 2 in. and 4 in. long but less than 12 times the plate thickness (Figs. 2.29, 2.30, 2.31).
2. Groove welded attachments with transition radius between 2 in. and 6 in.
 - Full or partial penetration weld in the direction of main member with end welds ground smooth. (Fig. 2.32).
 - Full penetration weld perpendicular to the attachment, plates of equal thickness, weld reinforcement removed or not removed, and soundness established by NDI. (Fig. 2.33).
3. Groove welded attachments with unequal plate thickness, weld perpendicular to attachment, weld reinforcement removed, and a transition radius of at least 2 in. (Fig. 2.34).
4. Fillet - welded attachments with transition radius 2 in. or larger and end welds ground smooth. (Fig. 2.35).
5. Riveted connections, net section. (Fig. 2.36).

2.7 Categories E and E'

Details in this categories have the lowest fatigue strength in comparison to those in other categories. Generally, for welded details in this group with the same configurations, Category E' applies if the flange plate thickness exceeds 0.8 in. or if the attachment plate thickness is 1 in. or more.

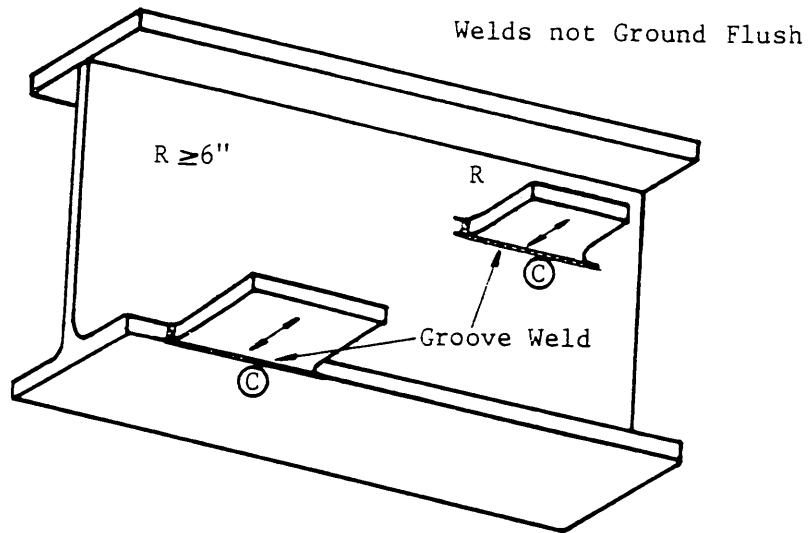
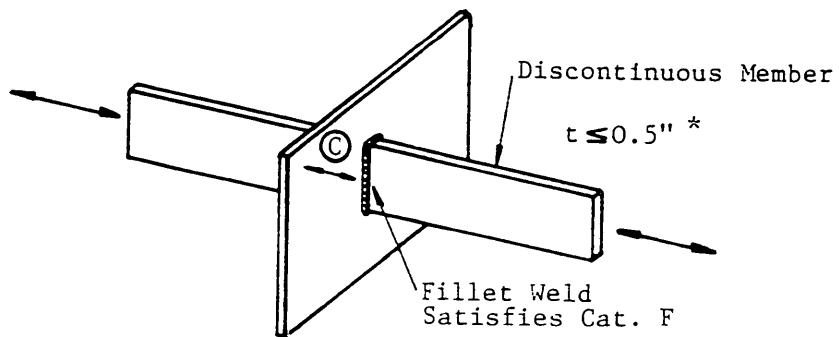

Fig. 2.25. Category C - Transverse Groove Welded Attachment, Weld Not Ground Flush



* Reduction of fatigue strength if to > 0.5"

Fig. 2.26. Category C - Fillet Welded Connection (Load Carrying)

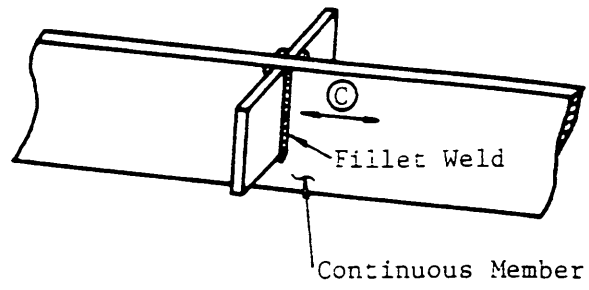

Fig. 2.27. Category C - Fillet Welded Connection (Non Load Carrying)

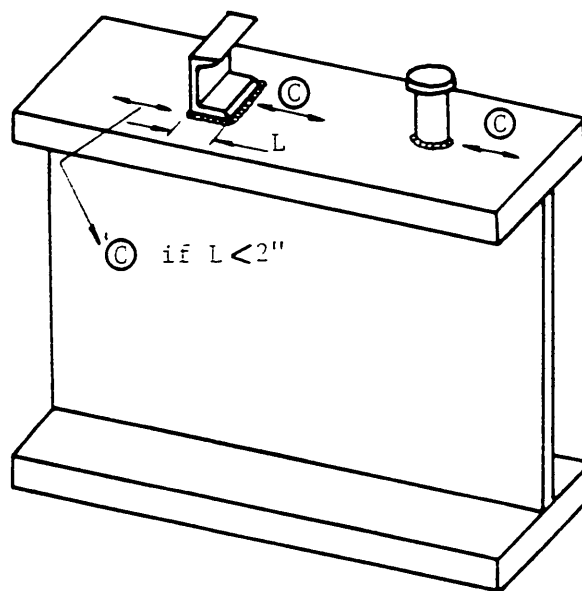

Fig. 2.28. Category C - Stud Shear Connectors

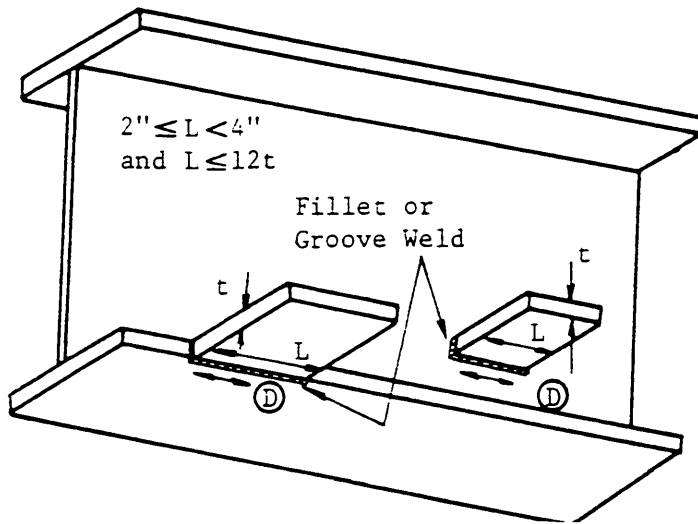

Fig. 2.29. Category D - Groove or Fillet Welded Attachment, Intermediate Length

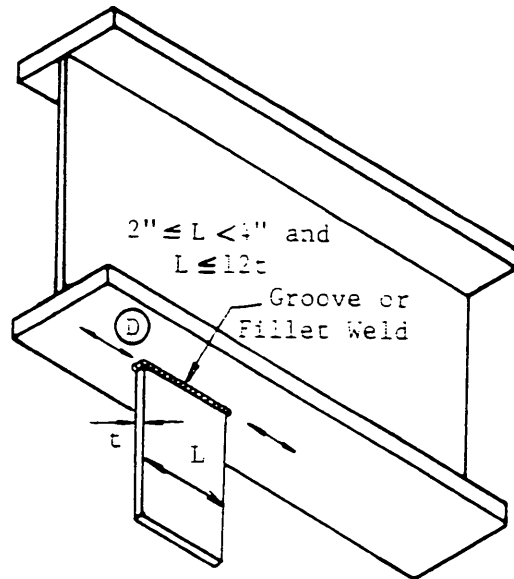

Fig. 2.30. Category D - Welded Gusset Plate, Intermediate Length

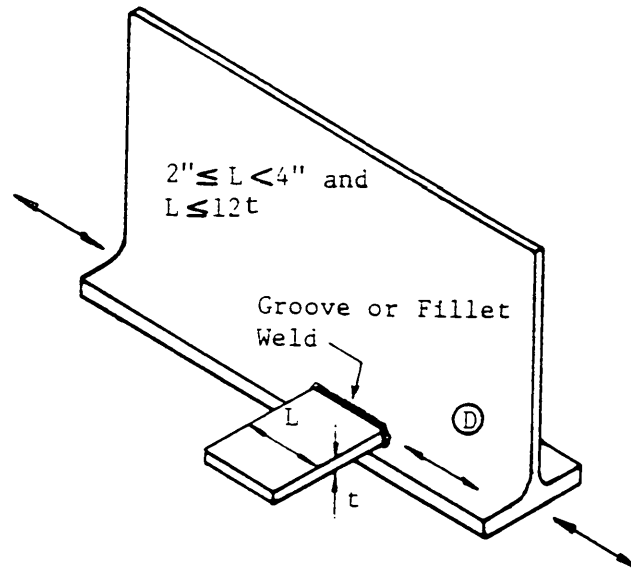

Fig. 2.31. Category D - Welded Gusset Plate on Rolled Shape, Intermediate Length

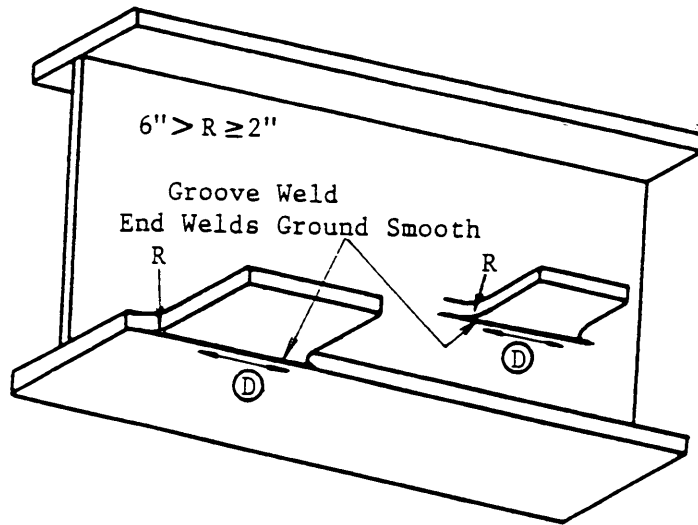

Fig. 2.32. Category D - Longitudinally Welded Attachment, Short Transition Radius

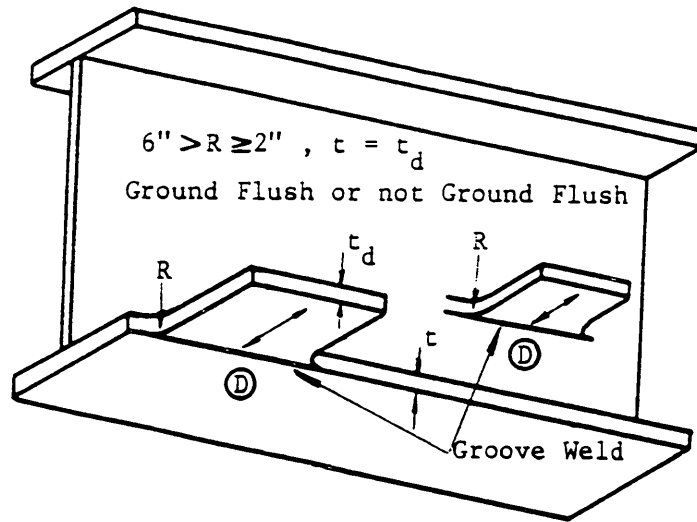

Fig. 2.33. Category D - Transversely Welded Attachment,
Short Transition Radius

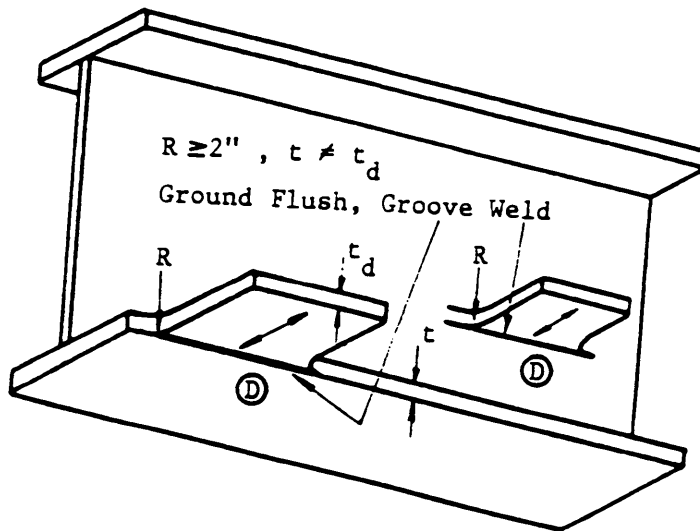

Fig. 2.34. Category D - Transversely Welded Attachment,
Unequal Plate Thickness

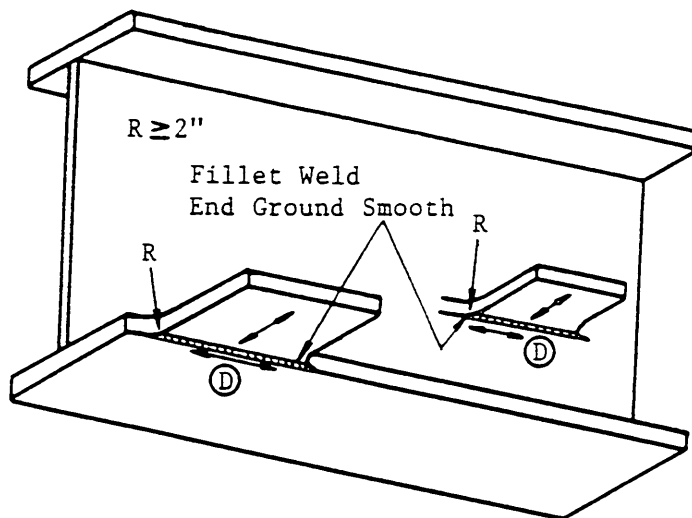

Fig. 2.35. Category D - Fillet Welded Attachment, Transition Radius 2" or More

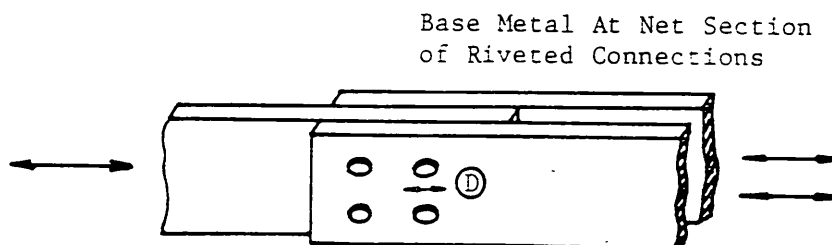

Fig. 2.36. Category D - Riveted Connections

1. Ends of partial length cover plates on girder or beam flanges.
 - Cover plate narrower than flange plate, with square or tapered ends, with or without welds across the ends. (Fig. 2.37).
 - Flange thickness 0.8 in. or thinner, Category E
 - Flange thickness greater than 0.8 in., Category E'
 - Cover plate wider than flange plate, with welds across the ends (Fig. 2.38)
 - Flange thickness 0.8 in. or thinner, Category E.
 - Flange thickness greater than 0.8 in., Category E'.
 - Cover plate wider than flange plate, without welds across the ends: Category E' (Fig. 2.38).
2. Welded attachment, with groove or fillet weld in the direction of the main member, more than 4 in. or 12 times the plate thickness. (Figs. 2.39, 2.40).
 - Thickness of plates less than 1.0 in.: Category E.
 - Thickness of plates 1.0 in or more: Category E'.
3. Welded attachment with curved transition:
 - Transition radius less than 2 in., end welds ground smooth: Category E (Fig. 2.41).
 - End welds not ground smooth: Category E. (Fig. 2.42).
4. Welded attachment with loads transverse to welds.
 - Groove welded attachment, with soundness of weld established by NDI.
 - Transition radius less than 2 in: Category E (Fig. 2.41).
 - Unequal plate thickness and weld reinforcement not removed: Category E. (Fig. 2.43).
 - Fillet welded attachment
 - Transition radius less than 2 in. and end welds ground smooth: Category E. (Fig. 2.41).
 - End welds not ground smooth: Category E. (Fig. 2.44).

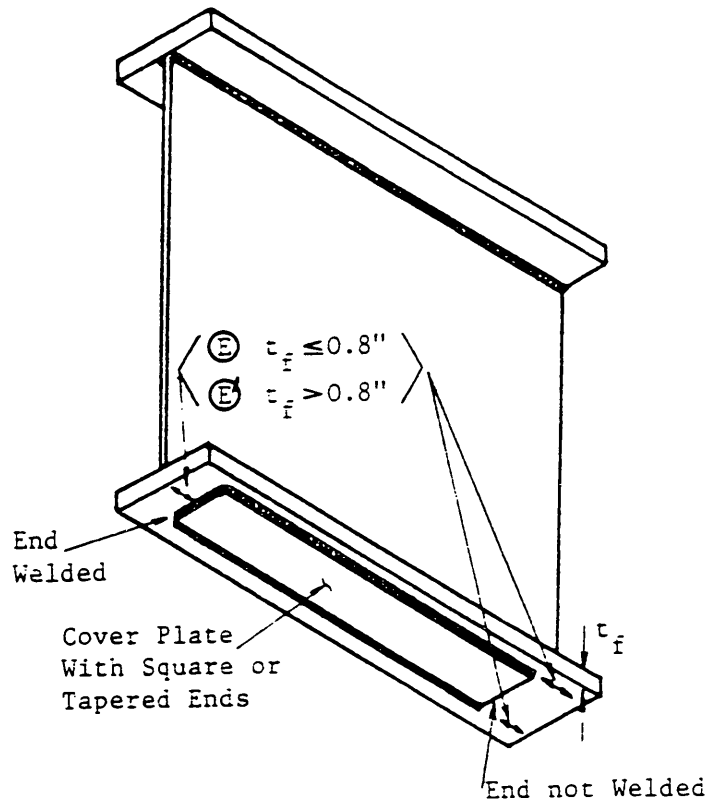

Fig. 2.37. Category E or E' - Ends of Welded Cover Plate

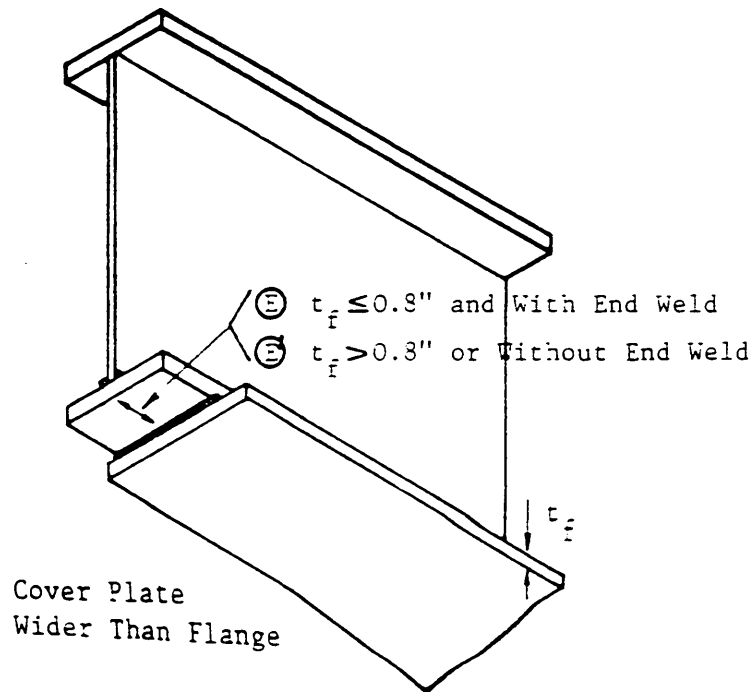

Fig. 2.38. Category E or E' - Ends of Wider Cover Plate

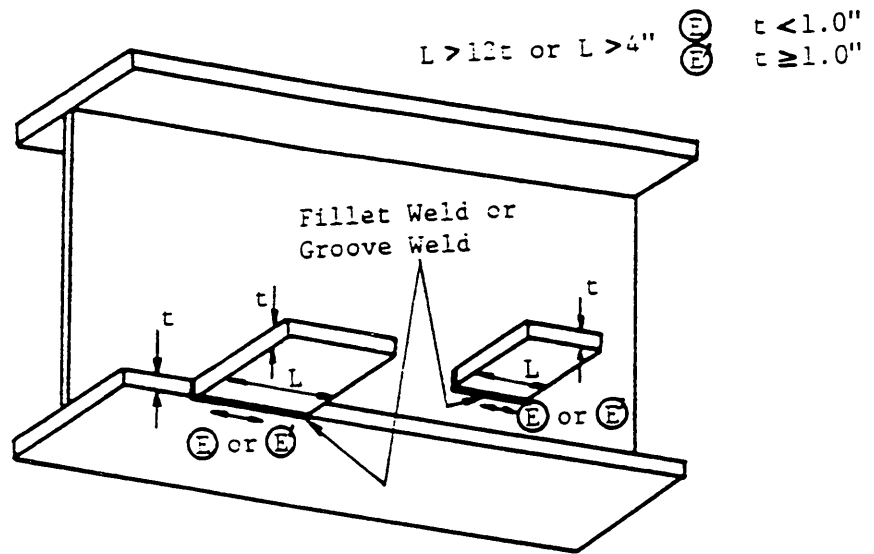

Fig. 2.39. Category E or E' - Longitudinal Welded Attachment

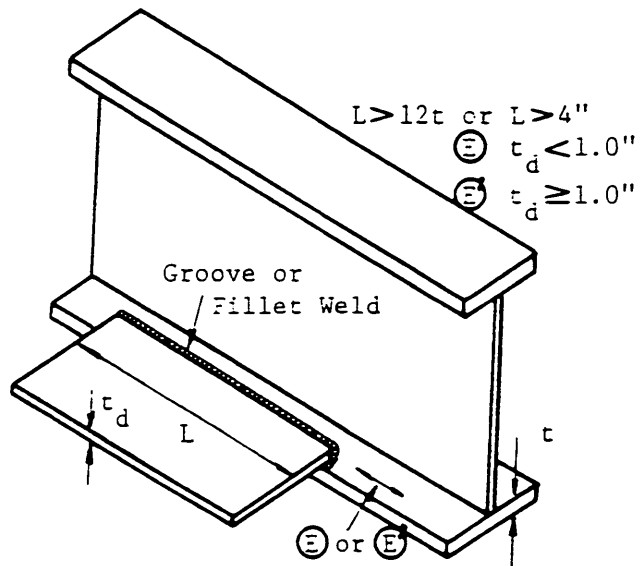

Fig. 2.40. Category E or E' - Longitudinally Welded Attachment (Lap Joints)

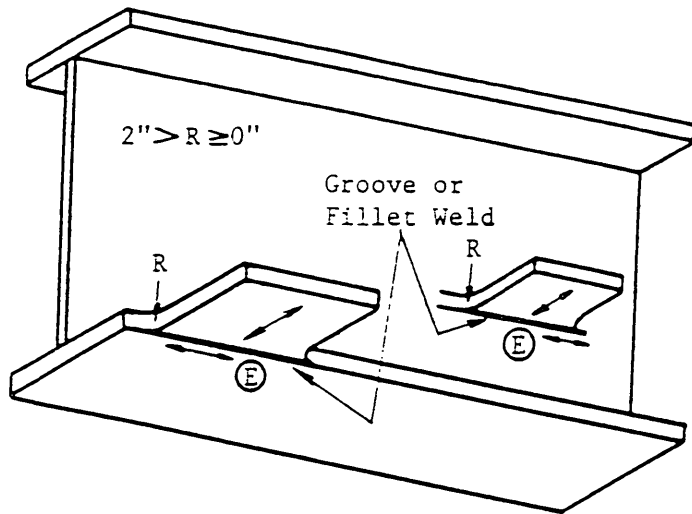

Fig. 2.41. Category E - Welded Attachment,
Very Short Transition Radius

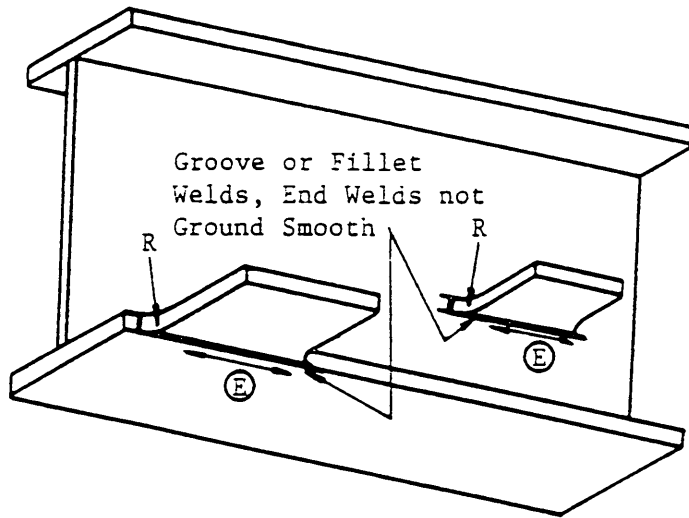

Fig. 2.42. Category E - Longitudinally Welded Attachment,
Any Transition Radius

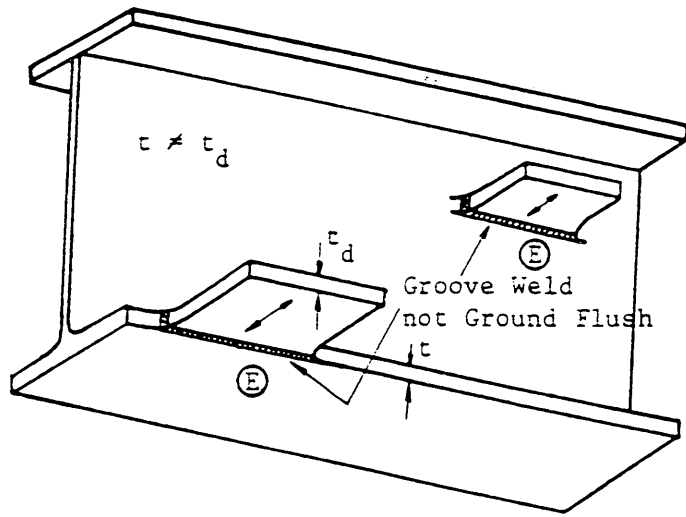

Fig. 2.43. Category E - Groove Welded Attachment,
Transverse Load

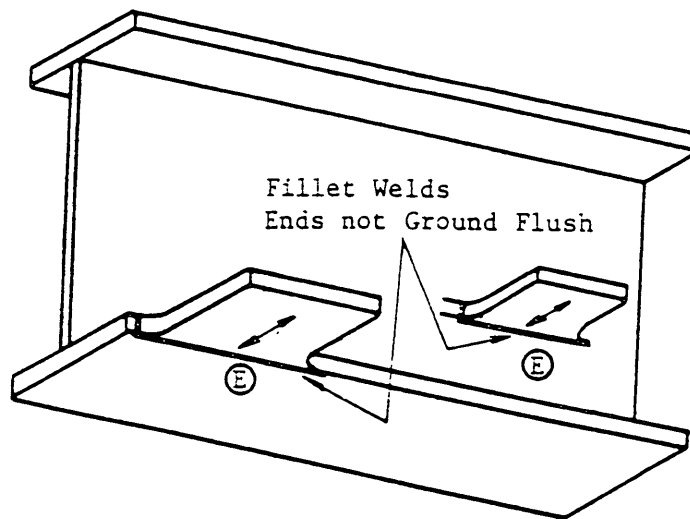

Fig. 2.44. Category E - Fillet Welded Attachment,
Transverse Load

5. Intermittent fillet welds: Category E. (Fig. 2.45).

Limited experimental data indicate that the fatigue strength of small scale specimens is more closely represented by Category C (reference 3). The design stress range limitation for this detail has been maintained at the lower Category E in order to discourage its use.

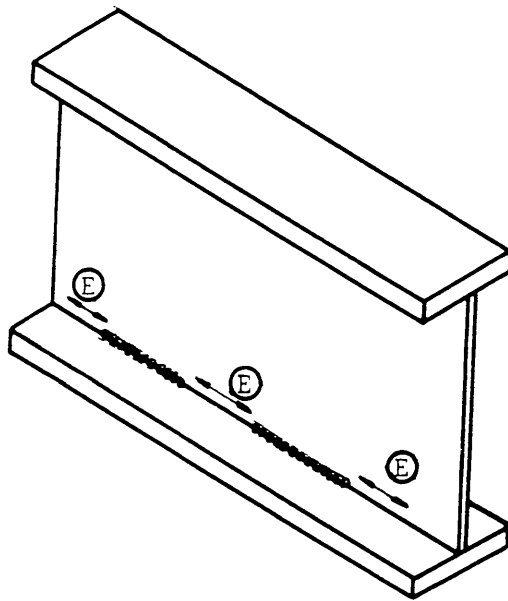

Fig. 2.45. Category E - Intermittent Fillet Welds

CHAPTER 3. INSPECTION TECHNIQUES

3.1 Visual Inspection

The most important and most frequently used method of inspecting bridge components for fatigue damages has been, and remains to be, the relatively elementary method of visual inspection.

After the detection of a crack or suspected crack, other nondestructive inspection methods can be used to verify the crack, as well as to examine similar locations at other component details. These nondestructive methods include the use of dye penetrant, magnetic particles, ultrasonics, acoustics, eddy current, and radiography. Most of these methods require carrying an instrument to the location of the crack, an inconvenience which drastically reduces the speed of inspection.

Confirmation of cracks can also be made by in-depth visual inspection using a magnifying instrument with the paint carefully removed from the suspected area. It is very important not to smear the suspected crack if it is small. If the confirmation of a possible crack is to be conducted by another person, it is advisable not to disturb the suspected crack area so that the re-examination of the actual conditions can be made. The use of degreasing spray before and after removal of the paint may help in revealing the crack. Removing of paint can be done using a wire brush, sand blasting, or grinding, depending on the size of the suspected crack.

While the use of special instruments or inspection aids to confirm suspected fatigue cracks is essential, and should be considered as a necessary step when an examination of traffic conditions, design stresses and local conditions strongly suggest its use, visual inspection of bridge components at susceptible locations remains the first-line action. Where are these likely locations of fatigue cracks and what signs suggest possible cracks are the important knowledge which will help inspectors in achieving an effective and efficient inspection.

3.2 Signs Suggesting Possible Cracks

When a crack is long, clearly visible, and opening and closing with traffic loads passing over the bridge, the existence of the crack is beyond doubt. More often, fatigue crack development is at an early stage when inspected, and there is no visible movement of the crack. The determination whether it is a crack is generally difficult. Yet some signs can provide strong suggestion of possible existence of a crack.

The most revealing sign is the existence of rust, or oxide film and powder. Figure 3.1 shows a line of oxide film along the end of a cover plate welded to the flange of a bridge girder. Such oxide film is usually a sure indication of a fatigue crack beneath the length of the film. Discoloring of paint film in a line along a connection is often an indication of a crack. Figure 3.2 shows this condition along the stiffener-to-web weld on a welded plate girder. Microscopic examination of a core cut from this area confirmed the existence of a small crack, developed at the weld toe and propagating into the thickness of the web plate.

Occasionally, crack development results from small relative deflection between adjacent parts of a connection. Oxide particles or powder may appear due to rubbing (working) of these parts. This situation is depicted in Fig. 3.3 a photograph taken at the upper end of a diaphragm connection plate adjacent to the top flange of a plate girder. A small crack existed in the web along the top flange because of the out-of-plane deflection of the web plate. Figure 3.4 shows the oxide particles at a rivet of a beam flange. A fatigue crack was detected in the flange angle, below the rivet head.

Sometimes, the movement at or near a small crack generates oxide powder which is not visible. However, because of the high humidity below the bridge deck, the condensed moisture could combine with the powder at the point of movement, resulting in the phenomenon of "bleeding". An example is shown in Fig. 3.5. This condition generally indicates the existence of a fatigue crack in the region.



Fig. 3.1. Oxide Film Along End of Welded Cover Plate

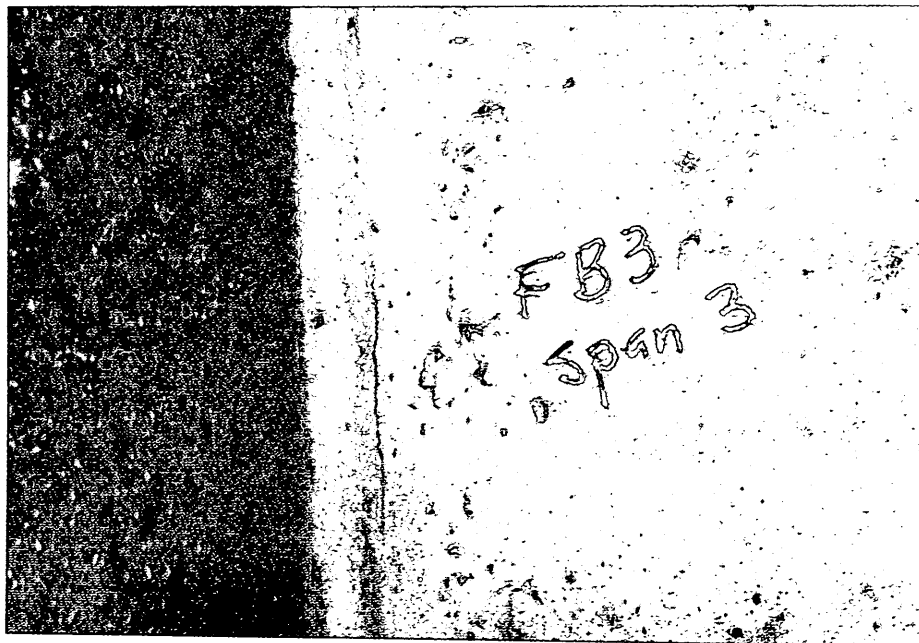

Fig. 3.2. Discoloring of Paint Film



Fig. 3.3. Oxide Particles due to Rubbing of Parts

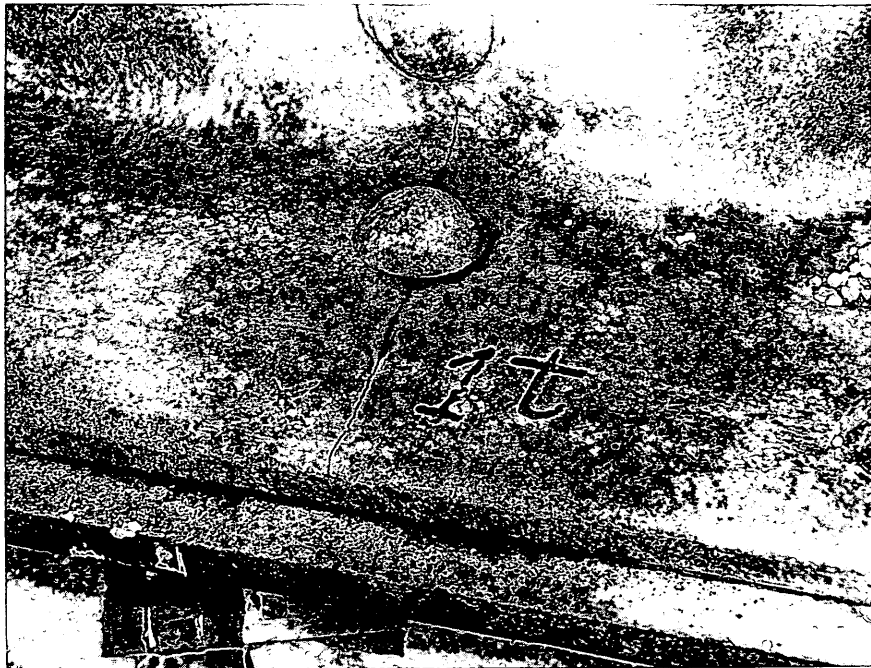

Fig. 3.4. Oxide Particles at Rivet

These and other signs of possible fatigue cracks are invaluable aids to inspection. Once a location is found to have some of these signs and a fatigue crack is detected, other similar locations should be inspected.

3.3 Where to Inspect

The development of a fatigue crack is controlled by the number of load applications (number of stress cycles), the magnitude of live load tensile stresses (stress ranges), and the size of the initial defect or flaw. Therefore, locations where the values of all these three factors are high or large need to be inspected more frequently and more carefully than those locations where the values of the factors are low.

Examination of fabricated and manufactured bridge members and components have shown that initial defects occur more frequently and are often larger at the connections joining members and components. Furthermore, connections are where stress concentrations exist due to change of geometry and dimensions. Therefore, fatigue cracks most often develop at or near joints and connections in bridges on high traffic volume arteries. These locations should be inspected.

The severity of influence of geometrical changes on the development of fatigue cracks in bridge component members, joints and connections is reflected in the AASHTO fatigue strength categories described in Chapter 2. Of all the joints and connection details, those of Category E' or E are the most susceptible to fatigue crack growth. Obviously, these Category E' and E details must be examined at every occasion of scheduled inspection of frequently travelled bridges.

Other locations where fatigue cracks have been detected often are joints and connections subjected to unintended forces or displacements. Although the structural detail may have a high fatigue strength, such as Category C or even B, the unintended forces and displacement generate high magnitudes of stress range and cause the development of fatigue cracks.

Diaphragm and floor beam connections at girder webs are two such problem locations. The connections between stringers and floor beams, and between girders and pier caps of transverse girders, are other examples. Lateral bracing connections on truss or girder structures are also locations where many fatigue cracks have been detected, particularly when the laterals are connected to gusset plates on girder webs adjacent to floor beam or diaphragm connections of plate girders. At all these connections, the relative stiffness and rigidity of the component members are generally not taken into consideration in design, as it is not required by rules and specifications. The out-of-plane forces due to differential displacement of the adjoining members can induce very high cyclic stresses and cause fatigue cracks to develop.

At or near joints and connections where the conditions of original installation have changed due to corrosion, lack of maintenance, alteration, or adding of secondary and auxiliary components, unintended forces and stresses may occur and lead to fatigue cracking. These details include pin-connected suspension hangers of plate girder bridges and long truss bridges, frozen eyebar heads, malfunctioning bearings, severely corroded components and attachments. These are often located at expansion joints which permit water, debris and deicing agent to accumulate in the area. Members at severely corroded joints and frozen movable connections need to be carefully inspected.

Examples of fatigue cracks at some of these details and connections are presented in the following chapters. It is important to remember that, among similar details of a bridge, those experiencing higher live load stresses and those behaving different from the simplified design assumptions, are more susceptible to fatigue crack development. These details, particularly those constituting parts of a fracture critical member, must be inspected thoroughly.

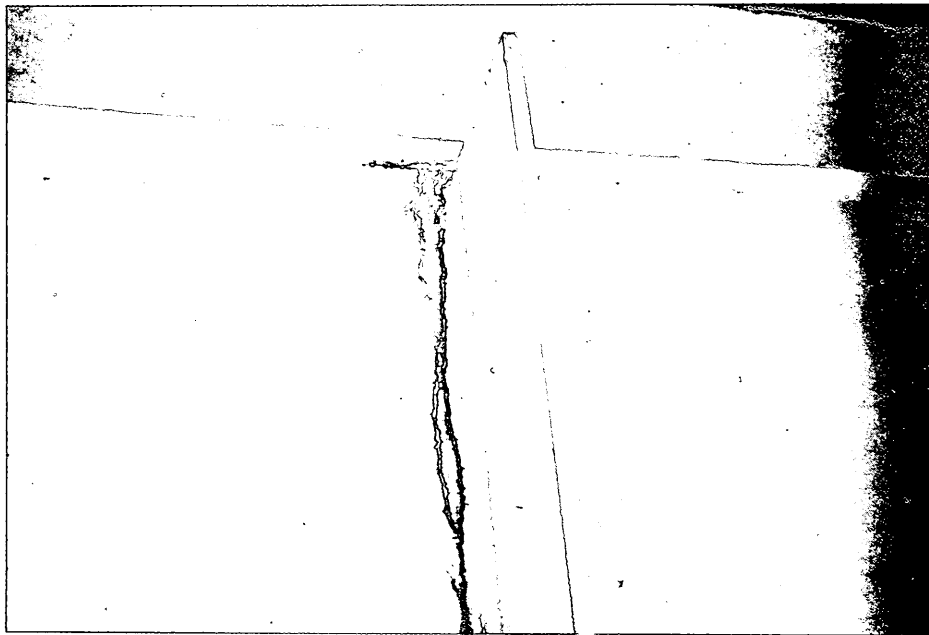

Fig. 3.5. "Bleeding" at Crack

3.4 Documentation of Fatigue Damage

When a fatigue crack or suspected crack has been detected, all relevant information should be recorded.

1. The date the crack was detected, confirmed, and re-examined.
2. The general location of the crack, such as: “at panel point L4 of the upstream truss”, or “at the upper end of connection plate of floor beam No. 5 to the south girder of the eastbound bridge”, etc.
3. Detailed sketches of the location, orientation, length, and width of the crack. Extra care should be given to determine the location of the ends of the crack.
4. The dimensions and details of the member containing the crack.
5. Any noticeable conditions at the crack when vehicles traverse the bridge, such as opening and closing of the crack, visible distortion at the local area, etc.
6. Any configurational and geometrical conditions of other members or components adjacent to or near the cracked member, which may have deviated from the expected, or which may have been altered after erection of the bridge.
7. The condition of corrosion, accumulation of dirt and debris, etc., at the general location of the crack.
8. Weather conditions when the crack was discovered or inspected.

These data are important for the evaluation of the cause of fatigue damage and the method of retrofitting.

CHAPTER 4. FATIGUE DAMAGE AT WELDED BRIDGE DETAILS

4.1 Residual Stresses, Initial Flaws and Crack Growth

Joining of bridge components by welding generates tensile residual stresses at and near the welds. The magnitude of these tensile residual stresses are usually at the level of the yielding stress of the steel. Furthermore, the internal flaws in welded details are usually larger than those in rolled steel shapes and plates. Consequently, with accumulating number of live load and stress applications, fatigue cracks usually develop at welded details, not in the base metal of steel bridge members. In addition, the severity of detail geometry affects the stress concentration and stress distribution at the details, and dictates the fatigue strength of these details. Thus, for a magnitude of nominal live load stress range, ends of welded cover plates incur fatigue cracks before welded transverse stiffeners which, in turn, incur fatigue cracks before the plain welded beams and girders, (Fig. 2.1). Recognizing these characteristics, that is, the fatigue strength categories of welded details, is an important step for an effective and efficient inspection of fatigue cracks in welded bridges.

Because the critical residual stresses are tensile at the welded details, applied compressive stresses only reduce the magnitude of the tensile stresses in and at the weld, but do not eliminate them. The live load stress range is effectively in tension. Therefore, fatigue cracks can develop at welded details in the nominally compression regions of steel bridge members. However, when a crack propagates out of the tensile residual stress zone and into the adjacent compression region, the stress state at the end of the crack changes and crack growth usually stops. With recognition of this phenomenon, it becomes apparent that the inspection of welded details in regions of nominal compressive stress is of lower priority than in tension regions.

In tension regions of steel bridge members, fatigue cracks generally propagate in a direction perpendicular to the maximum tensile principal stress. Therefore, fatigue cracks

which develop in tension flanges of beams and girders with welded cover plates will grow into the flange and, through the flang-to-web weld, into the web plate (Fig. 4.1). Similarly, a fatigue crack developed at the weld between the horizontal gusset plate and the vertical floorbeam connection plate of a plate girder bridge can propagate into the web plate through the welds connecting these attachment plates to the web (Fig. 4.2). Knowing these likely crack growth paths facilitates crack inspection.

Examples of fatigue damages in welded steel bridges are given in the subsequent sections.

4.2 Fatigue Cracks in Main Members

4.2.1 Ends of Welded cover Plates

The ends of welded cover plates on tension flanges of rolled beams and welded built-up girders have the lowest fatigue strength of all the welded bridge details. Examples of fatigue crack are shown in Fig. 3.1 and Fig. 4.1. The cracks usually form in the flange plate at the toe of the fillet weld.

When a transverse end weld exists at the end of the cover plate, more than one small crack will develop, grow, and join together to form a single, long crack, as is the case shown in Fig. 4.3. The crack in this figure has not yet penetrated through the thickness of the flange plate. It is, however, obvious by visual inspection.

At the ends of cover plates without an end weld, the fatigue crack will develop in the flange plate at the ends of the longitudinal fillet welds. This and other cracks at various end conditions of welded cover plates are shown schematically in Fig. 4.4. Results of studies have shown that the differences of fatigue strength among these end conditions are minor⁽³⁾⁽¹⁸⁾ unless the cover plate is wider than the flange and has no end weld (Category E'). Another important influencing factor is the flange thickness: flange plates thicker than 0.8 in. have category E' fatigue strength.

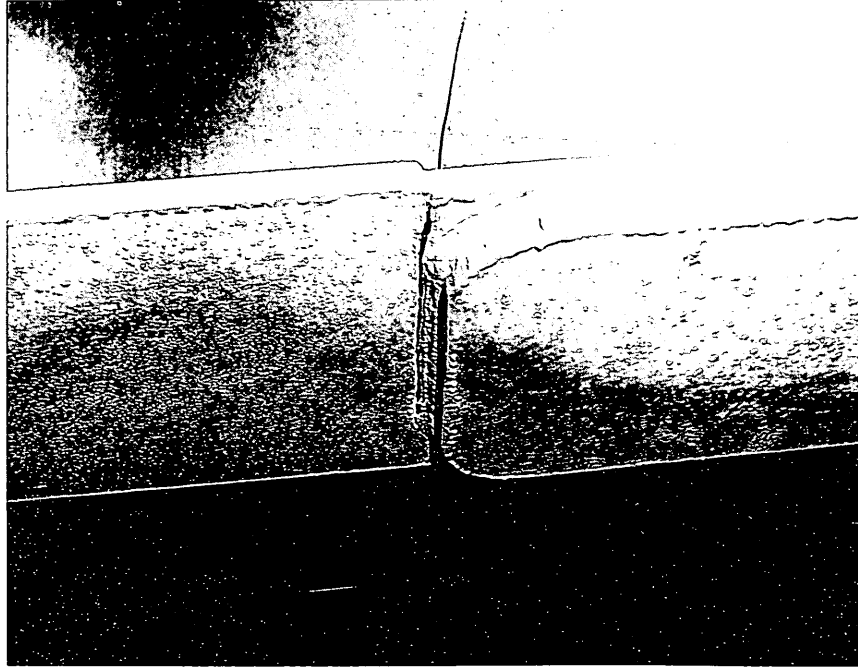

Fig. 4.1 Cracked Flange at Cover Plate

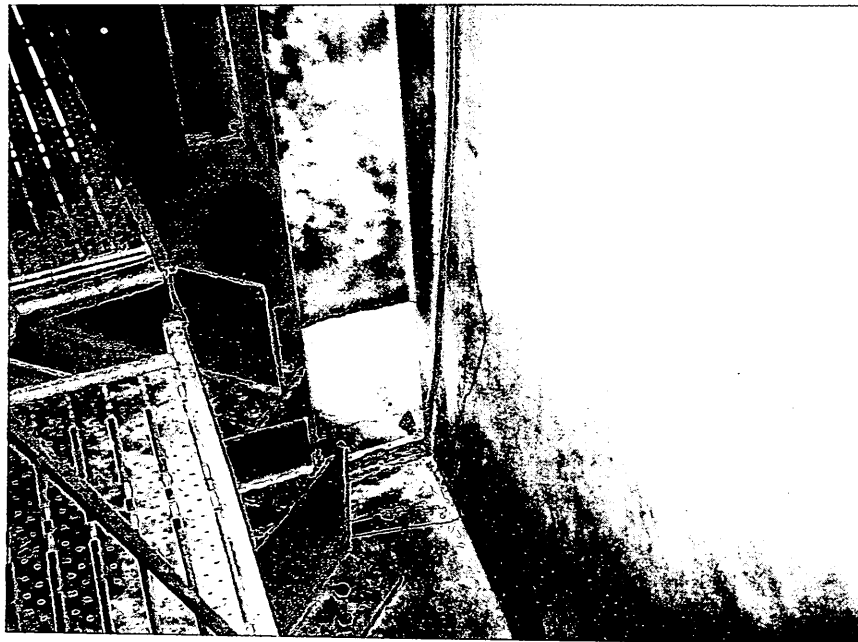
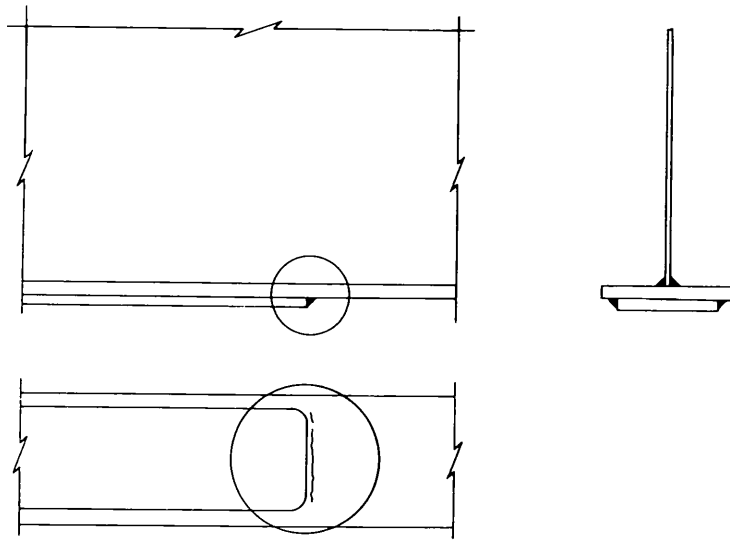

Fig. 4.2 Crack Propagating through Welds into Web Plate



(a)



(b)

Fig. 4.3 Crack at Welded end of Cover Plate

4.2.2 Groove Welds in Flange Plates

Groove welded splices exist in the flanges (and webs) of many bridges of relatively long spans, particularly in continuous girder bridges. The groove welds often join flange plates of different thickness and width. Nondestructive inspection of groove welds is required at the time of fabrication, and the normal fatigue strength is category B or C depending on the geometry of transition and the condition whether the weld reinforcement is removed. Fatigue damage to these welded splices is not normally expected.

However, the methods of nondestructive testing in the 1940's and 1950's were not as reliable as the modern procedures and repairs made during fabrication of the groove welds sometimes might not have undergone stringent scrutiny, even in the 1970's. Fatigue cracks have occurred in a number of groove welded flanges^(7,19). Figure 4.5 shows an example of a crack. The ground surface of the flange edge reveals that the crack developed from the edge of the protruding weld deposit (reinforcement) and grew into the flange for about half an inch. The crack was not visible without removing of the paint. There was no oxide coloring and the paint film was not cracked. The intensive inspection was undertaken because similar welds in another bridge had cracked and induced sudden fracture of a girder.

Groove welded splices in tension flanges made prior to the early 1970's or by the electroslag weld procedure should be inspected very carefully. The consequence of fatigue crack growth and fracture of a tension flange could be serious, and dictates careful inspection.

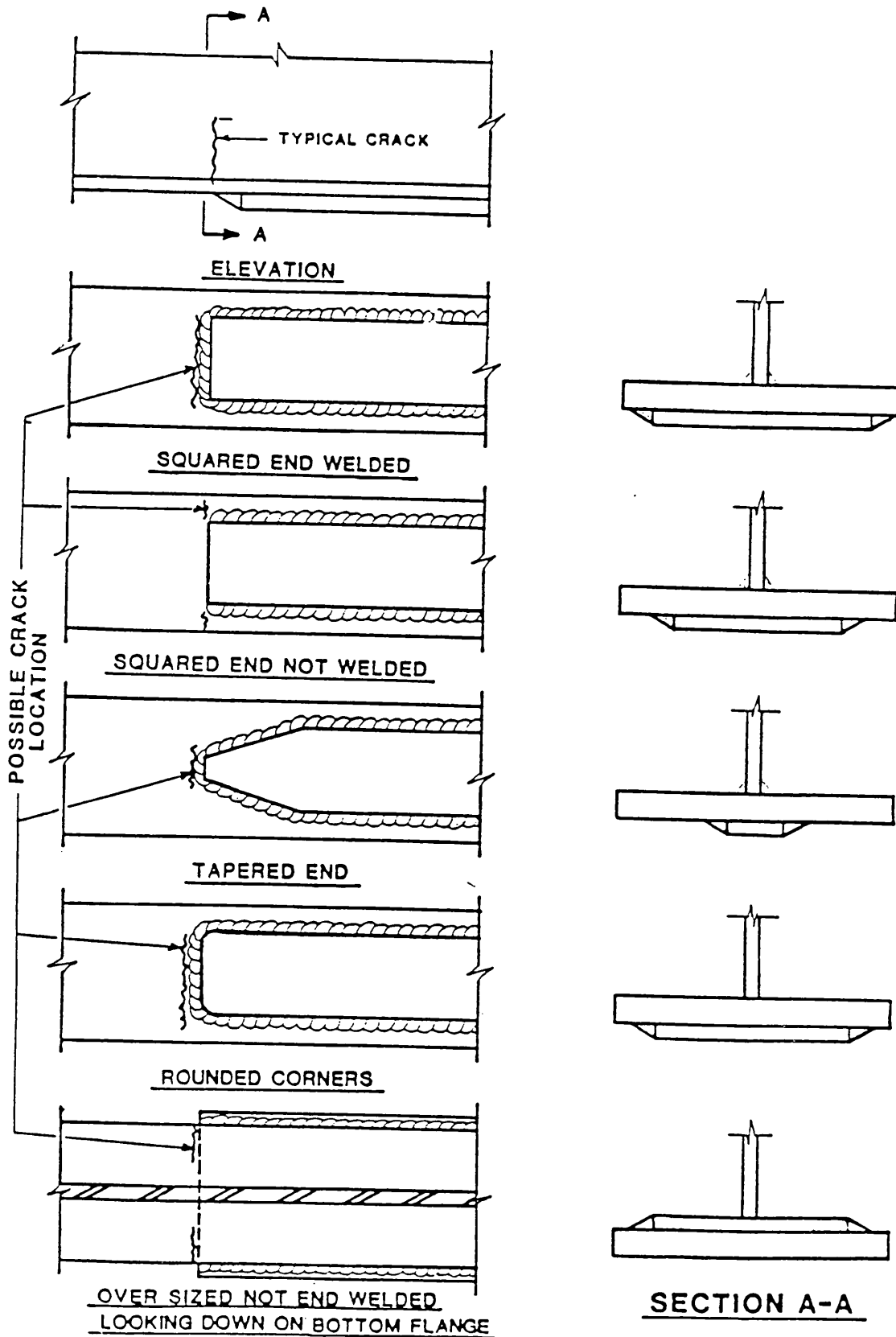
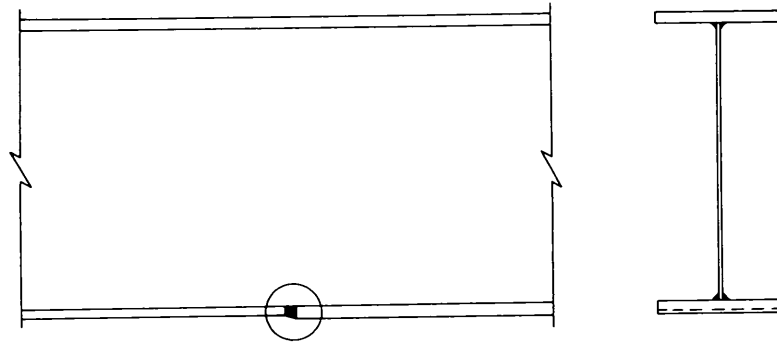

Fig. 4.4 Crack at Ends of Welded Cover Plates - Schematic



(a)



(b)

Fig. 4.5 Crack at Electroslag Groove Weld of Flange

4.2.3 Butt-Welds in Longitudinal Stiffeners

Longitudinal stiffeners on girder webs are normally in the compression zone of the web. For aesthetic reasons these stiffeners are often made continuous along the entire length of bridge spans in both the compression and the tension regions. Numerous fatigue cracks have been detected in butt welds in longitudinal stiffeners. An example is shown in Fig. 4.6.

Because of the length of the longitudinal stiffeners, butt welds often are necessary when fabricating the stiffener plates before welding them onto the web. These butt welds often are of low quality because the longitudinal stiffener was not considered as a load carrying member and no quality control was imposed. When the girders are placed in bridges and carry loads, the longitudinal stiffeners are subjected to the same stresses as do the web plates. The unintentional flaws can induce early development of fatigue cracks which propagate into the web and cause serious fatigue damages⁽²⁰⁾.

Obvious flaws and visible uneven surface conditions at butt welds of longitudinal stiffeners in tension regions of bridge girders should be carefully examined.

4.2.4 Web Plates with Cutout and Filler Welds

A relatively new type of bridge detail, used in welded continuous steel bridges since the 1970's, is shown in Fig. 4.7. The flange splice plate of girder flanges in adjacent spans is placed through an opening in the webs of a pier cap box girder (or through girder). The rectangular opening in the web is larger than the cross section of the splice plate, and the gap around the splice plate after its positioning is usually sealed by welds. This condition creates one of the worst details with respect to fatigue resistance (being lower than category E'). Many fatigue cracks have been reported at this detail^{(7,)(9)}. The box pier cap shown in Fig. 4.8 fractured from fatigue cracking at the detail.

The factors contributing to the low fatigue strength of this detail include the sharp re-entrant corner of the cutout in the web plate, the intersected groove welds (or seal welds) which often contain large defects (lack of fusion) because of the difficulty in welding, the

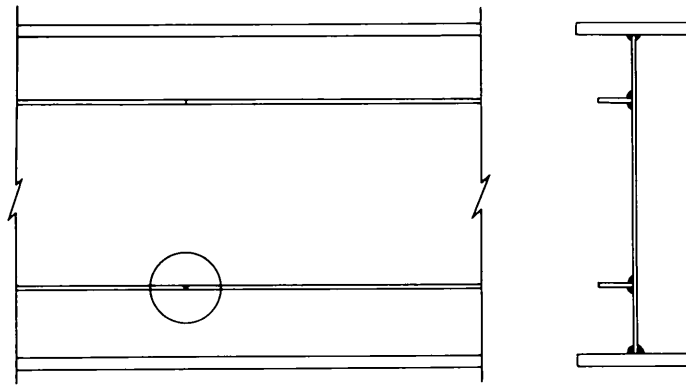

(a)



(b)

Fig. 4.6 Crack in Butt-Welded Longitudinal Stiffener

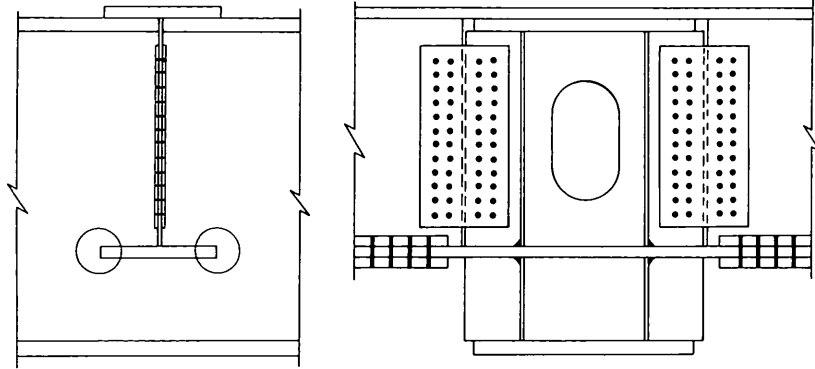

(a)

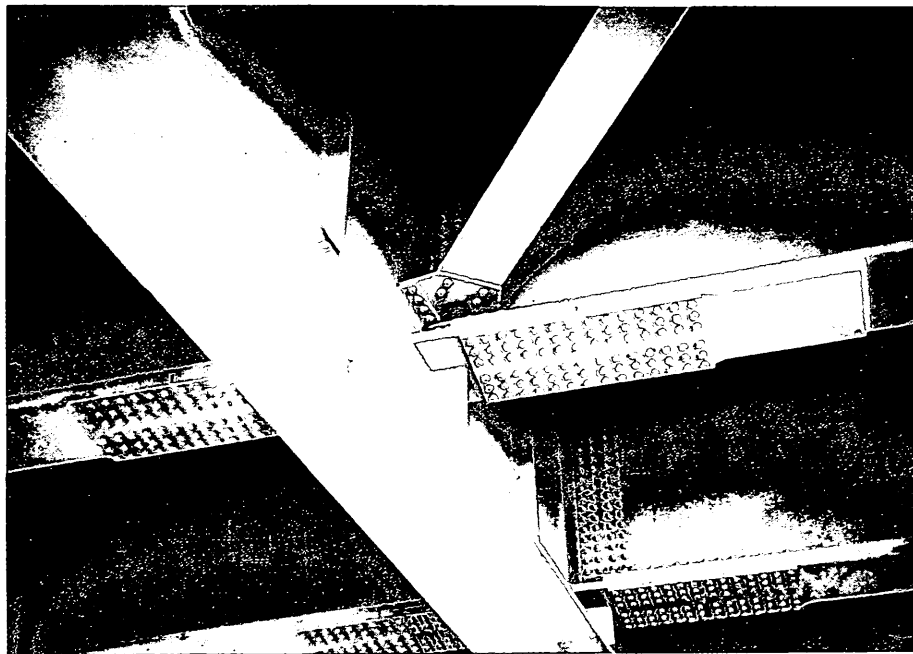

(b)

Fig. 4.7 Intersecting Members with Flange Splice Plate Passing through Web

relatively high magnitude of in-plane stresses in the lower portion of the web plate, and the often ignored out-of-plane forces from the girder flanges.

Inspection of this type of detail should be made from both sides of the web plate, if possible. Usually it is difficult to examine the detail from inside small box pier caps. Use of dye penetrant may facilitate detection of the crack, as is shown in Fig. 4.9.

4.2.5 Intersected Groove Welds

The condition of intersected or terminated groove welds in main members, similar to that of web cutouts discussed in the last section, exists in some bridges. Examples are insert plates for special fabrication and for repair.

To produce the haunched girder of Fig. 4.10a, a rolled beam was cut along a flange-to-web junction, a wedge-shaped plate was inserted in between, and welds were deposited all around the insert plate. This procedure created re-entrant corners in the web plate with intersected groove welds. The quality of the groove welds, particularly the short, vertical segments with termination at both ends, was of questionable quality. The primary stresses in the girder were perpendicular to these poor quality welds. A fatigue crack developed from the defects in the weld segments. The crack propagated up the web and down into the flange. It was detected through the observation of oxide (rust) on the paint and the breaking of the paint film, as is seen in Fig. 4.10b.

Any intersected or terminated groove weld in the tension region of bridge members should be inspected with care. Special attention should be given to those welds which are perpendicular to the direction of the tensile stresses in the member.

4.2.6 Welded Repairs and Reinforcement

Welded repairs and reinforcement on bridge members often decrease the fatigue strength while increasing the static strength of the member. This type of welded detail includes the placement of patch plates at corroded areas of bridge members, adding of strengthening

components, correction of fabrication errors, etc. Figures 4.11, 4.12 and 4.13 show some examples. The attachment of repair or reinforcement plates by welding usually creates a detail of low fatigue strength at the ends of the plates. Fatigue cracks could develop at this location.

The patch plates shown in Fig. 4.11 were installed to compensate for the reduced cross sectional area resulting from corrosion of the girder web. The short, vertical weld between two patch plates, similar to that of the terminated groove weld in Fig. 4.10 contained an initial flaw (lack of fusion). The fatigue crack started there and propagated across a longitudinal weld into a second patch plate.

The splice plates on the tension members of a truss bridge, shown in Fig. 4.12, were used to shorten the eyebar members. However, the welded reinforcing splice plates are of category E' in fatigue strength, corresponding to the ends at welded cover plates. Fatigue cracks in quite a few members of this bridge were detected through observations of oxide discoloring of paint, and was confirmed by examination of cut sections of a replaced member.

Occasionally, holes for bolts (or rivets) were misplaced in a bridge during fabrication. An example is given in Fig. 4.13. Because the holes did not affect the load carrying function, the member could be and was accepted for use. However, instead of leaving the holes alone, or using bolts, the voids were filled with weldment. Without proper attention during welding and without appropriate inspection, the quality of the welds was very poor. Fatigue cracks developed from two holes and led to fracture.

These and many other similar weld repairs and reinforcement in bridges should be carefully inspected.

4.2.7 The Splices in Backup Bars

Backup bars for full penetration welds between webs and flanges of box girders are usually left in place after fabrication. These backup bars are continuous in the direction of the box girder and sustain the same magnitude of strain as the web to flange junction. Figure 4.14a shows a schematic of the arrangement.

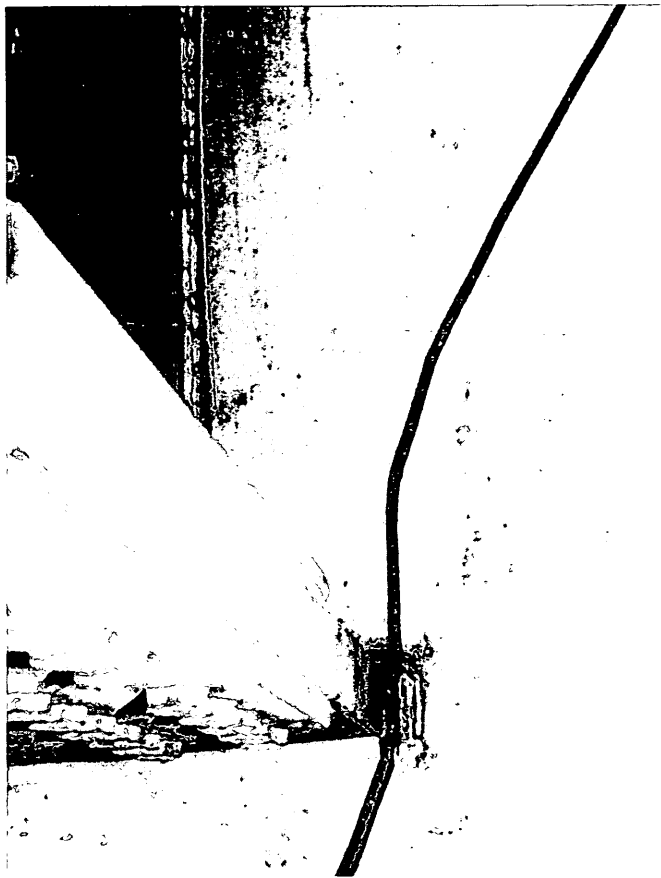
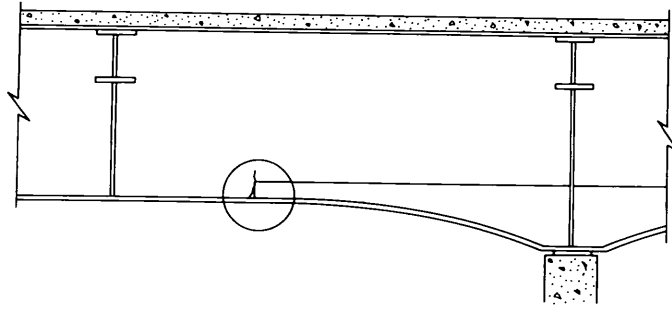

Fig. 4.8 Crack in Box Girder Web at Penetrating Flange Splice Plate



Fig. 4.9 Crack revealed by Dye Penetrant



(a)

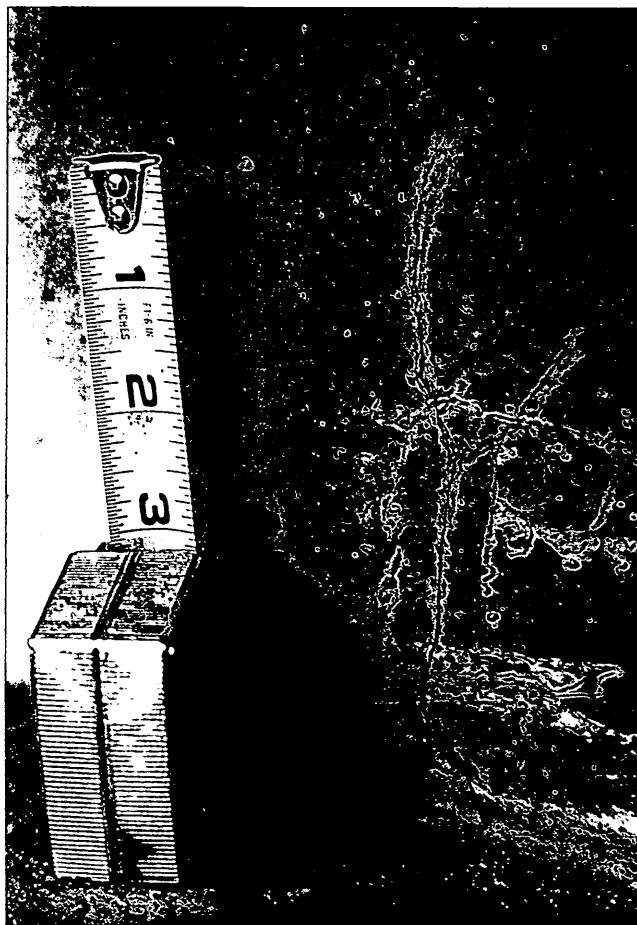

(b)

Fig. 4.10 Welded Insert Plate in Web



Fig. 4.11 Patch Plate on Girder Web along Flange Angle



Fig. 4.12 Splice Plate on Tension Member

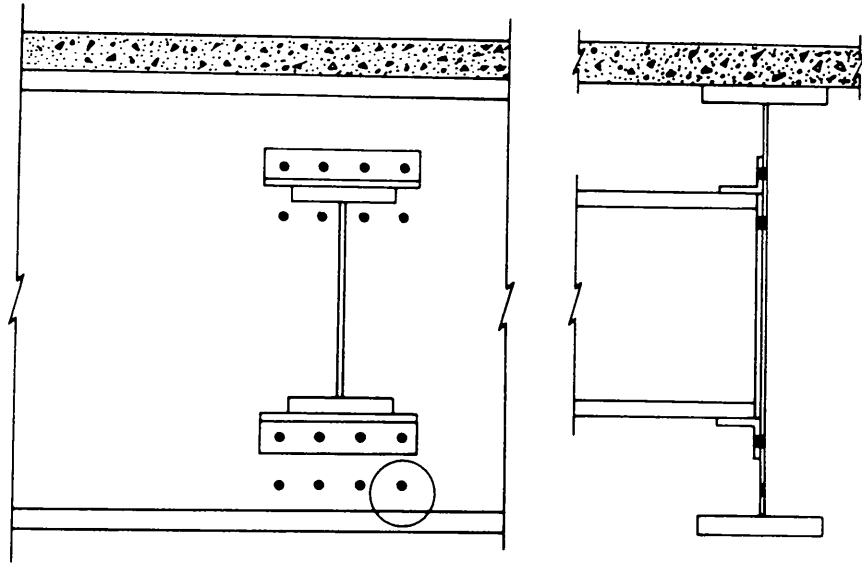

(a) Schematic showing location of misplaced holes.

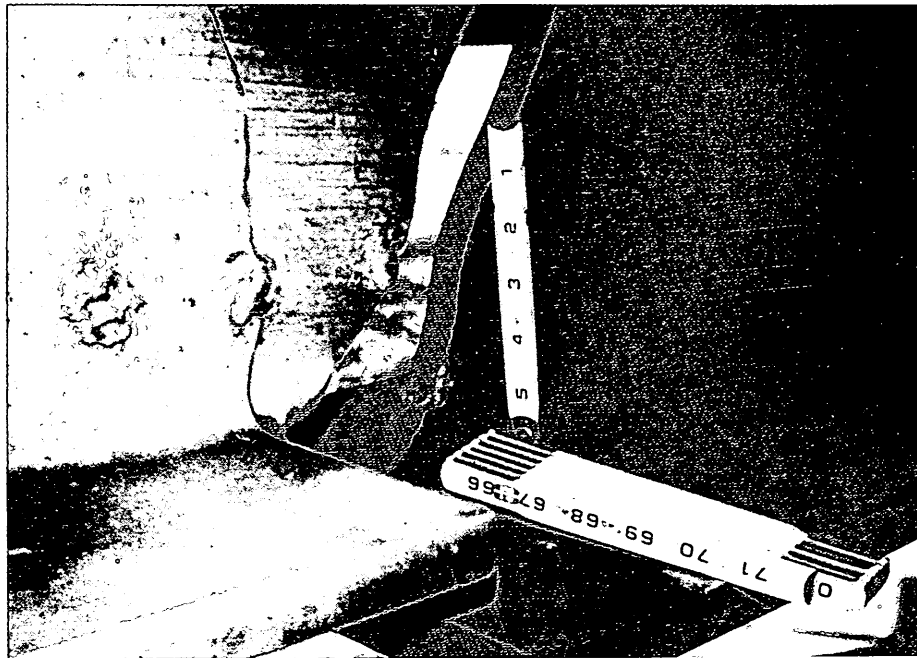

(b)

Fig. 4.13 Crack forming at Weld-Filled Holes

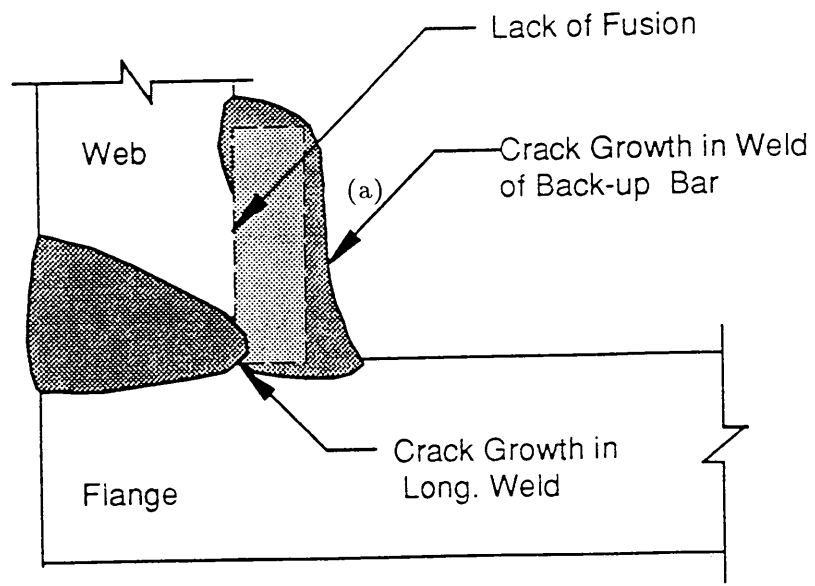

(a)

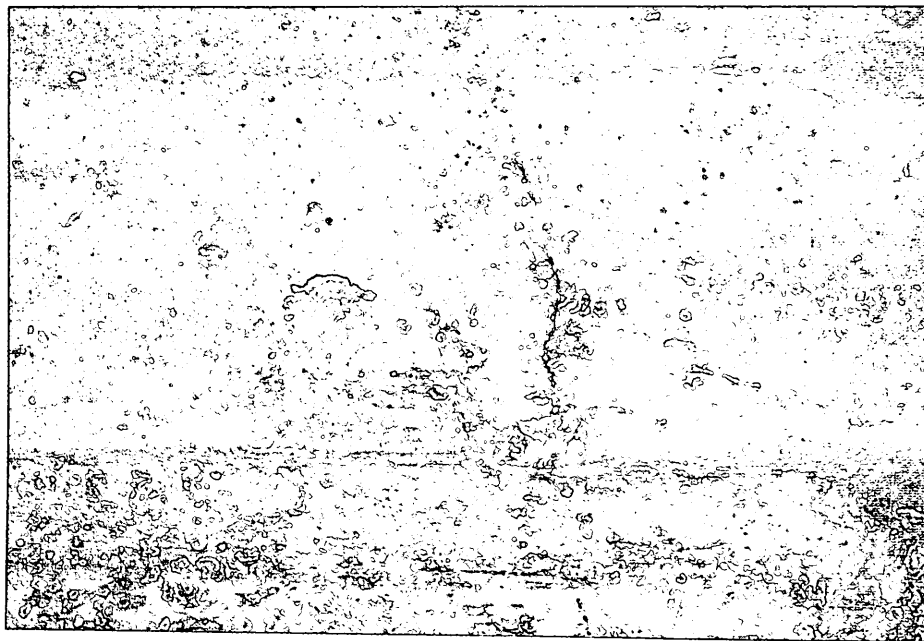

(b)

Fig. 4.14 Cracks Originating from Back-Up Bars

Similar to the situation of continuous longitudinal stiffeners on plate girder webs, butt splices of backup bars sometimes were not made with great care and no inspection was conducted. The lack of fusion developed into a fatigue crack in the butt splice shown in Fig. 4.14b. The crack is not apparent but is visible by careful visual inspection.

This type of fatigue crack can propagate into the flange and the web through the full penetration groove weld, and is perpendicular to the direction of the primary stresses in the box girder. Early detection of these cracks is essential.

4.3 Fatigue Cracks in Members at Connections and Attachments

4.3.1 Cut Short Flanges, Coped Beam Ends, and Blocked Flange Plates

Cut short flanges at ends of welded beams, coped ends of rolled shapes, and blocked flange plates, as illustrated in Fig. 4.15, facilitate the connection of stringers to floorbeams and floorbeams to girders as well as diaphragm connections. These details, particularly the cut short flanges and coped ends, constitute very abrupt reduction of member stiffness and induce high local stresses. Quite often, the re-entrant corner is sharp without transition, as in the case of cut short flanges of welded beams or the case of flame cut copes at beam ends. The high concentration of stresses add to the tensile residual stresses from welding or flame cutting, and often cause development of fatigue cracks.

Examples of fatigue cracks at ends of a diaphragm and a floorbeam are shown in Figs. 4.16 and 4.17. These cracks usually start at the re-entrant corner, either at the top or at the bottom flange depending on the local restraint and stresses, and propagate into the web. The diaphragm in Fig. 4.16 is a rolled shape and the floorbeam in Fig. 4.17 is a welded member. Many similar fatigue cracks have been detected at the ends of floorbeam and occasionally at the ends of stringers. Careful examination needs to be made at the weld termination of cut short tension flange plate of welded beams, and at the sharp re-entrant corners near tension flanges with rough edges and notches from flame cutting.

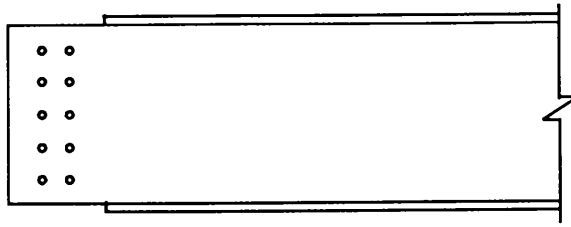

(a) Cut Short Beam Flange

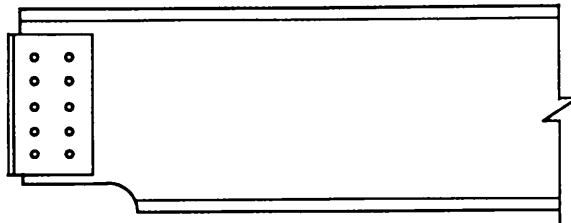

(b) Coped beam flange

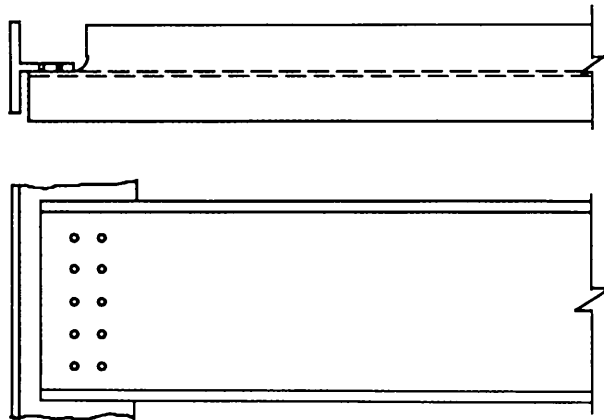

(c) Blocked beam flange

Fig. 4.15 Cut Short Coped and Blocked Beam Flanges

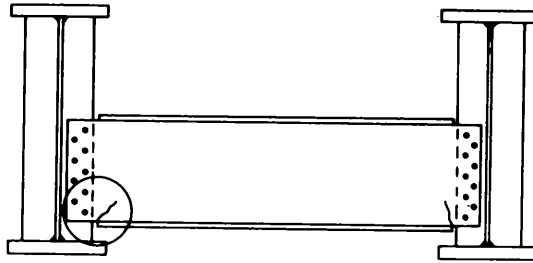

(a) Diaphragm with coped flanges showing likely crack development



(b) Fatigue cracking that developed at coped flange detail
Fig. 4.16 Cracking from Coped Flanges of Rolled Members



Fig. 4.17 Crack in Floor Beam Web at Cut Short Flange Plate

4.3.2 Welded Rigid Connections of Cross Girders at Bents

Full moment connections between cross girders and box-shaped columns of modern rigid frames serving as bridge bents are usually welded joints. The cross girders often are box girders, or I-girders with closure plates as stiffening elements at the junction. The full penetration welds between the girder flanges or closure plates and the column walls usually have backup bars inside the box or the enclosed area. These welds and backup bars are in a direction perpendicular to the primary stresses in the flange and the web of the cross girders. Furthermore, vehicles travelling across the bent from the adjoining bridge span often introduce horizontal bending and twisting of the cross girder. The number of stress range cycles are often quite high at these connections. Fatigue cracks can develop from initial defects in the welds or the lack of fusion defect at the backup bars.

Figure 4.18 shows a visible crack from the weld toe of the top (tension) flange of a cross beam in a bent column. Figure 4.19 shows a fatigue crack along the vertical weld of a box girder end connection at a bent column. The oxide discoloring of the paint in the former case is obvious, whereas the fatigue crack in the unpainted surface of the weathering steel of the latter example is not easy to detect. Careful removal of surface oxide by grinding often is necessary in order to locate the ends of the fatigue crack.

4.3.3 Welded Flange Attachments

Besides welded cover plates, a common type of welded attachment on girder flanges is the gusset plate for lateral bracing members. These gusset plates may be butt welded to the edge of the flanges or may lap the upper or lower surface of the flange plates and are attached by fillet welds. Because the length of the gusset plate usually is more than 4 in. long along the direction of the girder, and there is usually no gradual transition of geometry at the ends of the gussets, the fatigue strength of the attachment is of category E or E'. Fatigue cracks can initiate from the ends of the welds.

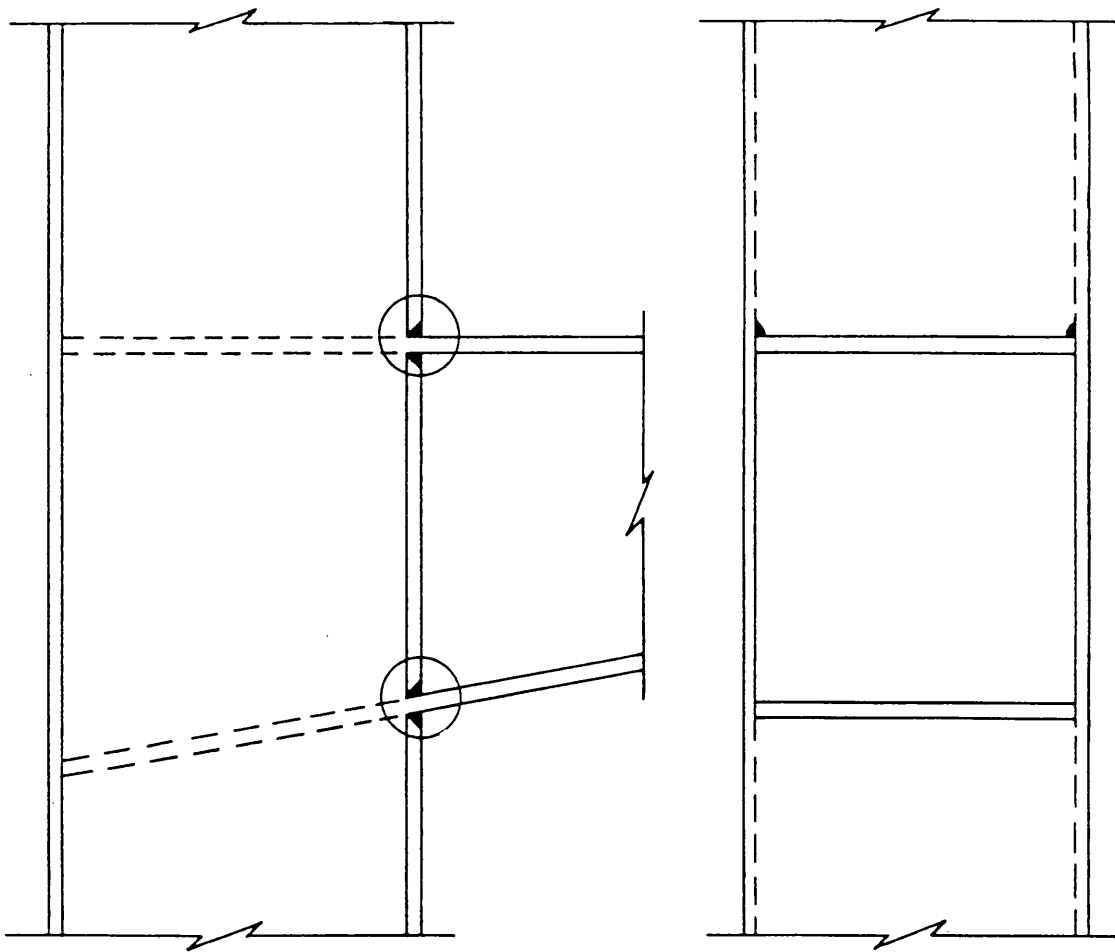

(a)



(b)

Fig. 4.18 Cracking at Cross Beam to Column Connections

The small crack in Fig. 4.20 originated at the end of a fillet weld which attached a lateral bracing gusset plate to a floorbeam flange. Detection was not difficult when the detail was examined with care. If not detected early, the crack can propagate into the flange plate and lead to severe damage. Quite a few bridge girders (and crane girders) have failed at this type of detail.

Other welded attachments on beam and girder flanges, such as small taps or brackets for anchoring catwalk hangers, drainage pipes, etc., usually are also category E details and need to be inspected if the attachment is on the tension flange. The welds between a tension flange and a vertical connection plate for an interior diaphragm of a girder bridge render the joint a category C detail with respect to the girder flange. However, the forces from the diaphragm could be high and could cause fatigue cracking. Careful inspection is necessary. Examples of some cracks are given in Section 4.4 of this manual.

4.3.4 Intersecting Welds at Gussets and Diaphragms

Intersecting welds at connections and attachments, similar to the intersected groove welds in the main members (Section 4.2.5), are undesirable and are often low in fatigue strength. An example is the attachment of a horizontal lateral bracing gusset plate to a girder web and to a vertical diaphragm connection plate without providing copes. A schematic is shown in Fig. 4.21. The longitudinal horizontal welds between the gusset plate and the web, and the transverse horizontal welds between the gusset and the diaphragm connection plate, intersect the vertical fillet welds of the diaphragm connection plate at a corner. Quite often weld defects exist in the transverse welds, and fatigue cracks develop. The crack can propagate through the corner and into the web plate. For the bridge girder detail shown in Fig. 4.2, the fatigue crack induced fracture of the girder.



Fig. 4.19 Fatigue Crack at End of Box Pier Cap at Bent

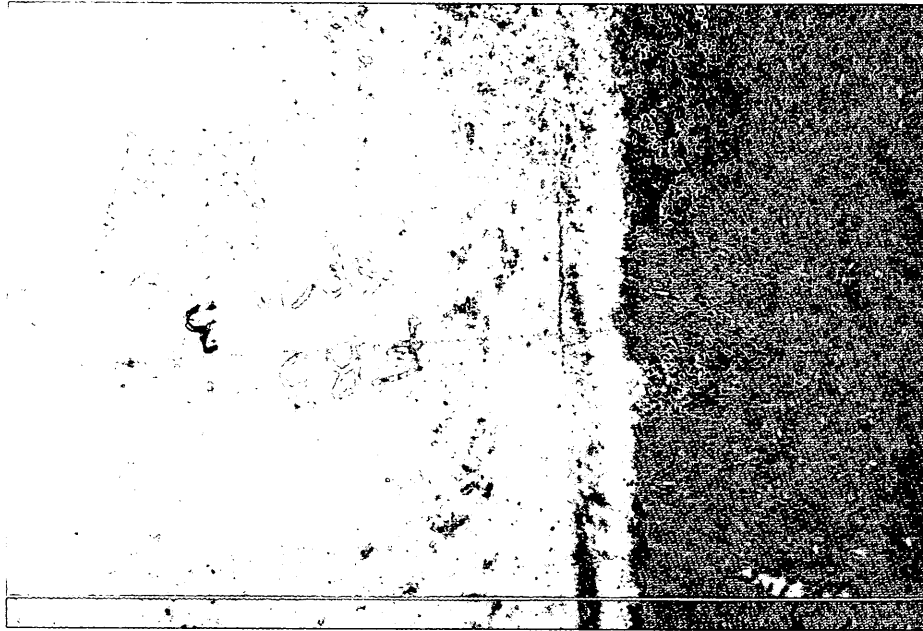

Fig. 4.20 Crack at End of Lateral Connections Plate Weld on Flange Tip

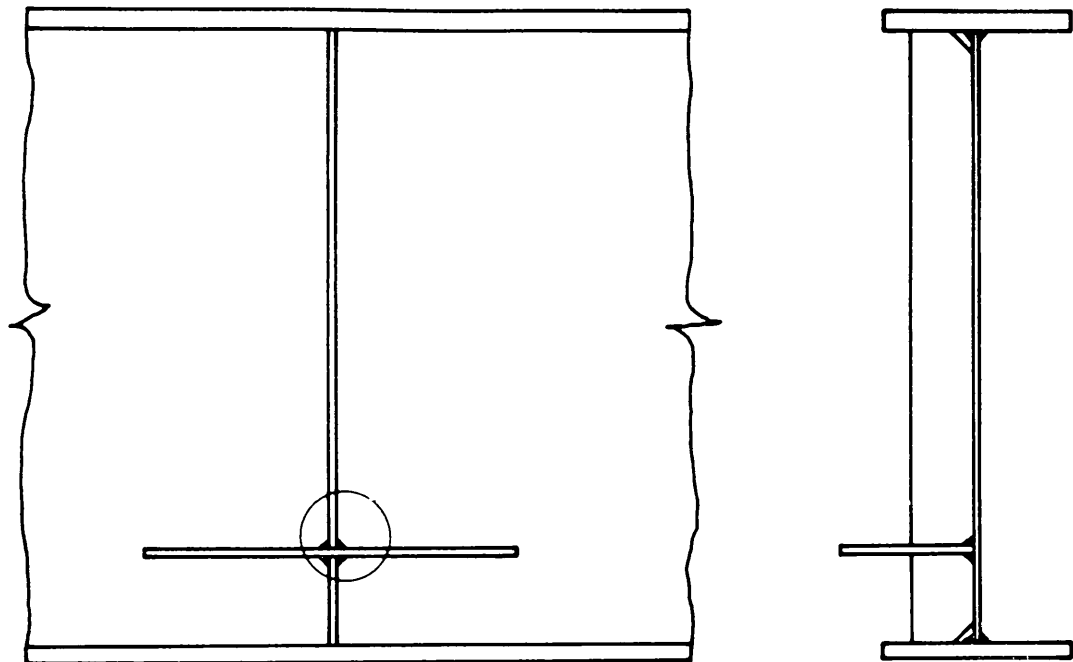

Fig. 4.21 Intersecting Welds at Gusset-Stiffener-Web Intersection-Schematic

Other possible locations of intersecting welds are at interior plate diaphragms of box girders, intersection of longitudinal and transverse stiffeners or diaphragm connection plates on girder webs, floorbeam end bracket connections to girder webs and flanges, etc. Inspection of all details of this type in tension regions of bridge members must be conducted frequently.

More examples of fatigue cracks in details with intersecting members (but not intersecting welds) are given in the next section.

4.4 Fatigue Damage Induced by Out-of-Plane or Transverse Forces and Deflection

4.4.1 Girder Webs at Floorbeam and Diaphragm Connections

Floorbeams and diaphragms between bridge girders exert out-of-plane forces to the girder webs through the vertical connection plates. The dimension of these connection plates are usually sufficient to transmit the forces but the structural details at the ends of the connection plates sometimes are inadequate to accommodate the deflections.

One type of connection detail which has incurred a large number of fatigue cracks is the end of floorbeam connection plates which are not attached to the top tension flange of continuous girder bridges. Examples are shown schematically in Figs. 4.22 and 4.23. While the top flange is rigidly embedded in the bridge deck slab, and the connection plate itself is stiff enough to resist rotation and bending from the floorbeam, most of the out-of-plane deflections (perpendicular to the web) concentrate in the local region of the web above the upper end of the connection plate. Fatigue cracks develop in the region as a result of the web plate bending. The cracks are usually horizontal along the web-to-flange weld, and also propagate as an upside down U along the upper ends of the fillet welds of the connection plate. Figure 3.5, which shows bleeding of the cracks, is a view of the cracks from the exterior surface of the web sketched in Fig. 4.22. Figure 4.24 shows the cracks on the interior surface of the web of Fig. 4.23. Detection of cracks of such length is not difficult. Knowing that unattached ends of floor beam connection plate are likely locations of fatigue cracks would increase the certainty of early detection of these cracks.

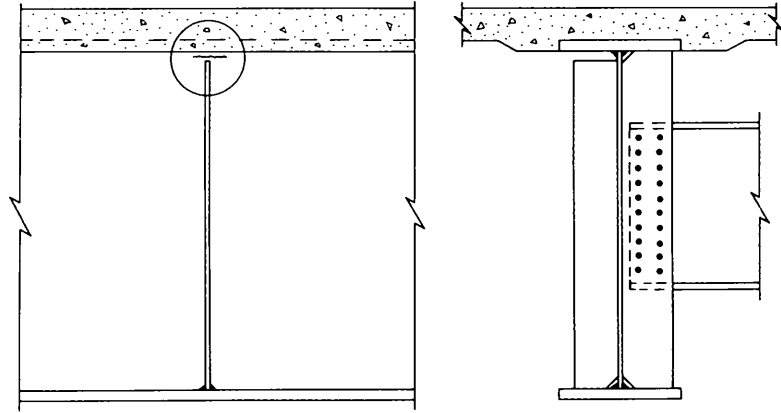

Fig. 4.22 Crack in Girder Web at Floor Beam Connection
Plate-Schematic

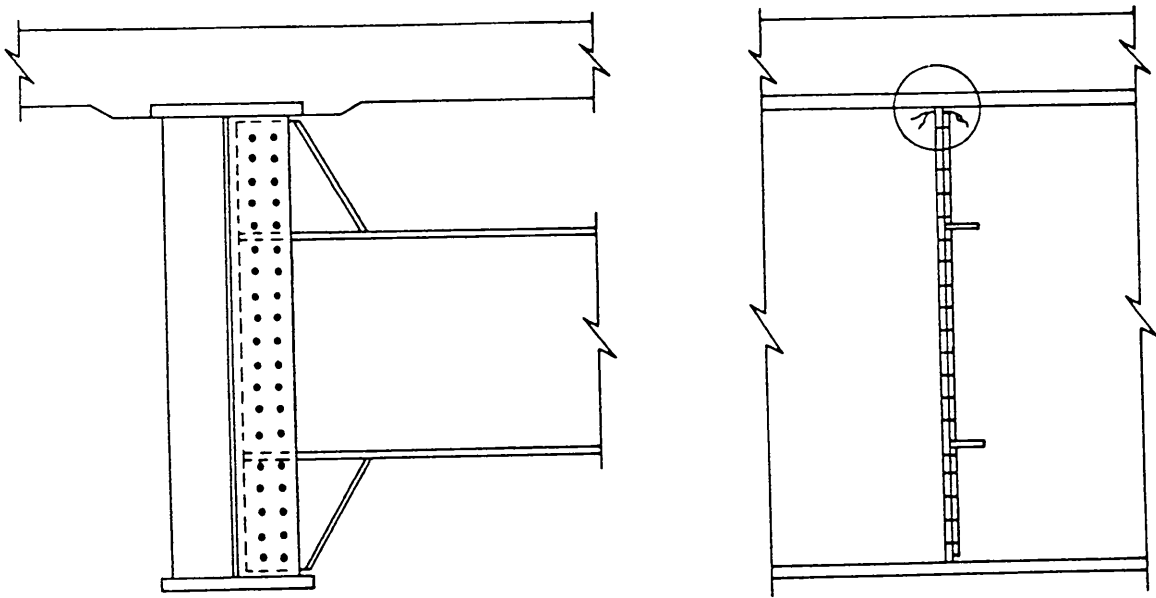

Fig. 4.23 Crack in Girder Web at Floor Beam Bracket
Connection-Schematic



Fig. 4.24 Fatigue Crack in Girder Web at Floorbeam Connection Plate

A similar situation exists at the ends of diaphragm connection plates which are not attached to the top tension flanges in continuous bridges. The lateral, out-of-plane deflection of the web in the region above the connection plate is induced by the diaphragm forces instead of the floor beam rotation and bending. Fatigue cracks develop along the flange-to-web weld and along the upper ends of the fillet welds of the connection plate. Figures 4.25 and 4.26 show two examples, one with X-diaphragms, the other with beam-type diaphragms. Both are susceptible to this mode of fatigue crack development.

At the lower end of floor beam and diaphragm connection plates which are not welded to the tension flange of girders, the condition of local out-of-plane deflection and bending of the web plate usually is less severe. This is because the tension flange is not restrained from lateral movement, which is sufficient to reduce the web plate bending. However, if the bottom flange is restrained from lateral deflection, fatigue cracks will develop along the web to flange weld. Figure 4.27 shows such a crack at the lower end of a floor beam connection plate above a bearing. The crack propagated beyond an intermediate web stiffener, and is clearly visible by the broken paint film and oxide. Similar cracks have been found where the lateral gusset plates are directly attached to the bottom flange. Figure 4.28 shows an example.

Another location where fatigue cracking has developed at the unattached lower end of diaphragm connection plate is in skewed bridges. Most of these diaphragms are perpendicular to the girders thus are subjected to large differential vertical deflections which in turn cause out-of-plane deflection at the lower end of the diaphragm connection plate. If the girder flange is relatively thick and stiff against lateral displacement, most of the deflection is accommodated by bending of the web plate within the gap between the flange and the end of the connection plate welds. Fatigue cracks may initiate. An example is shown in Fig. 4.29. The crack started at the bottom of the vertical plate, grew upward in a U-shape and then propagated horizontally into the web. "Bleeding" of the crack indicated that there was relative movement of the crack surface and moisture has combined with the oxide to streak



(a)

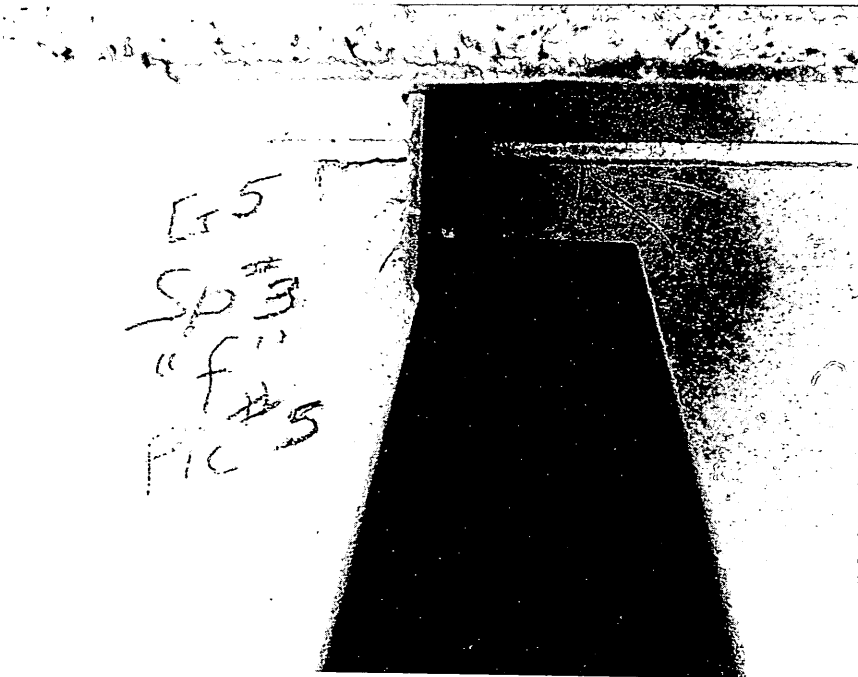

(b)

Fig. 4.25 Crack in Girder Web at K-Diaphragm Connection



(a)

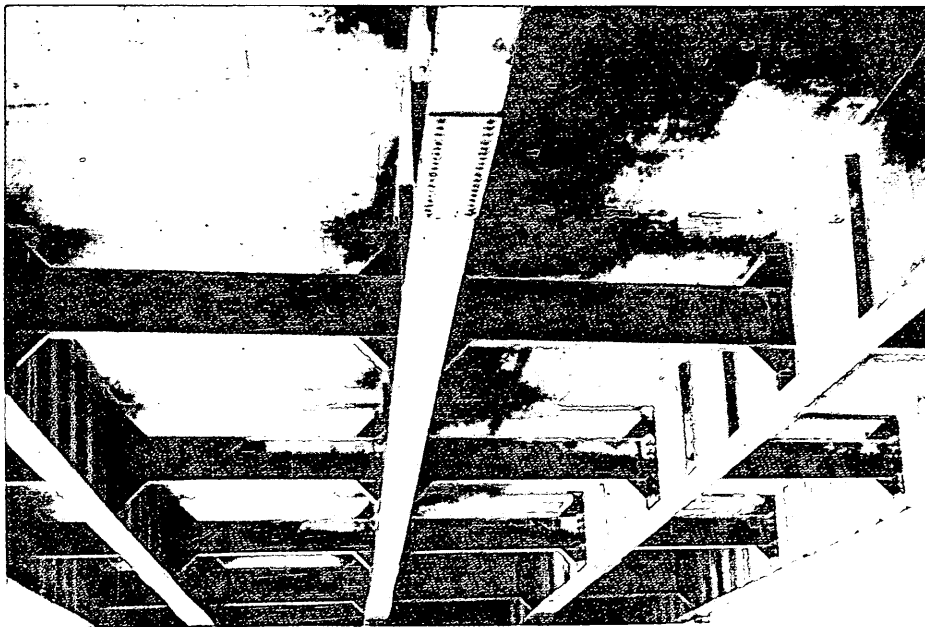
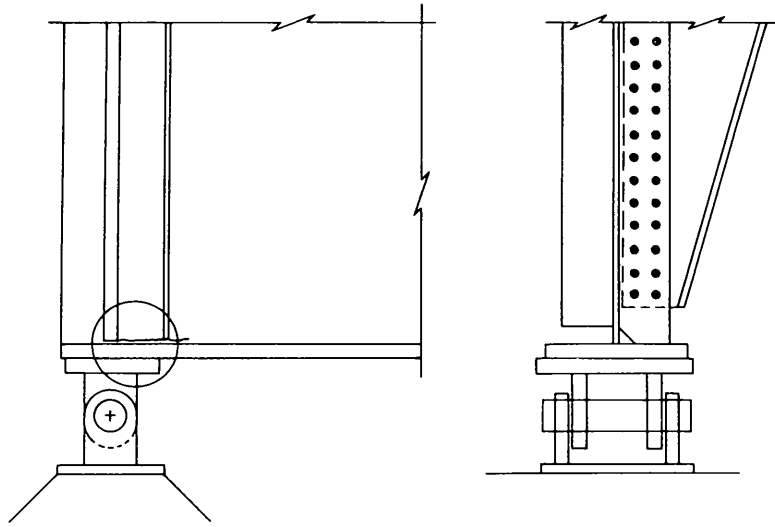
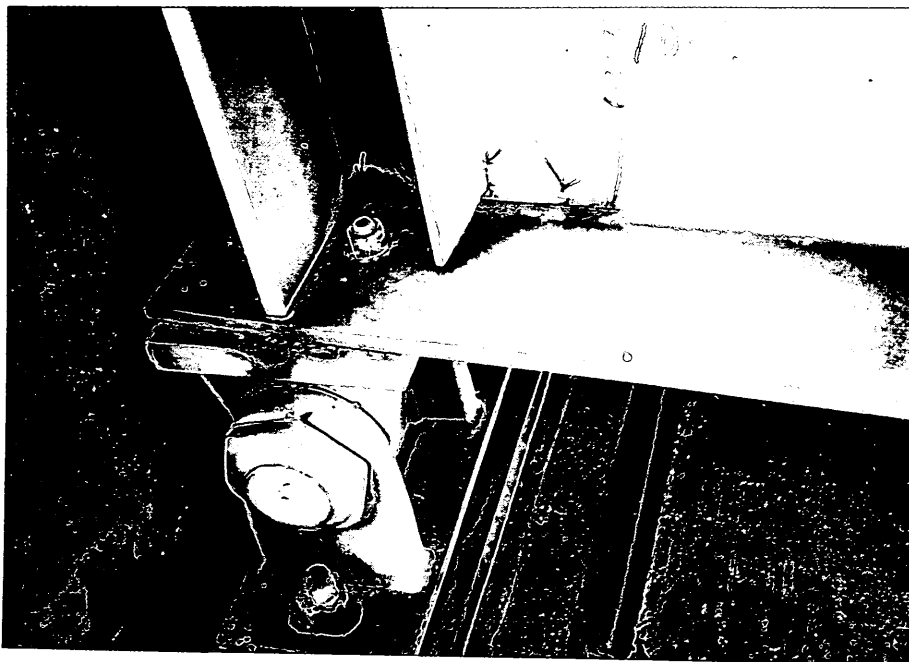

Fig. 4.26 Crack in Girder Web at Beam Type Diaphragm



(a)



(b)

Fig. 4.27 Crack in Web near Support

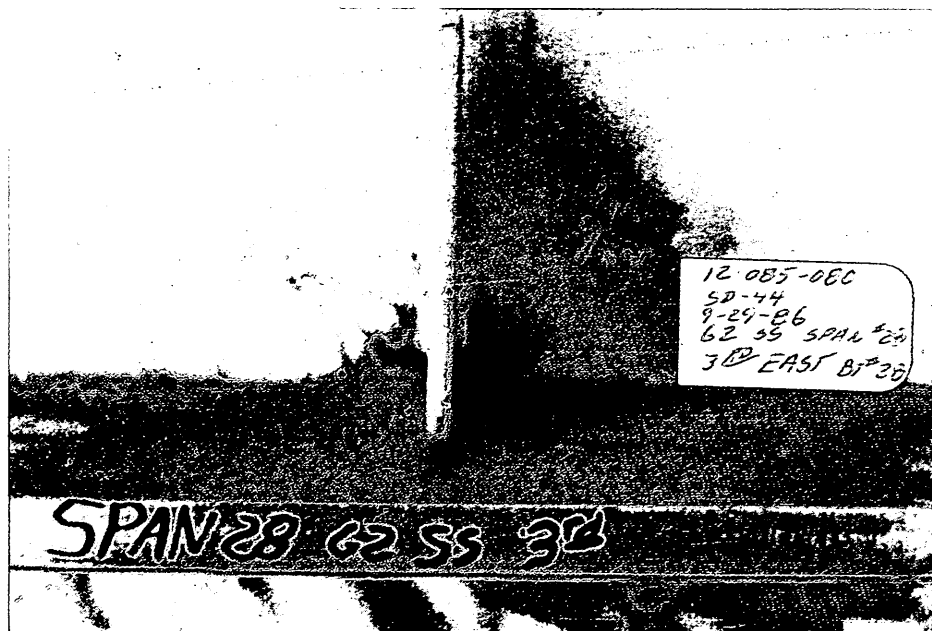
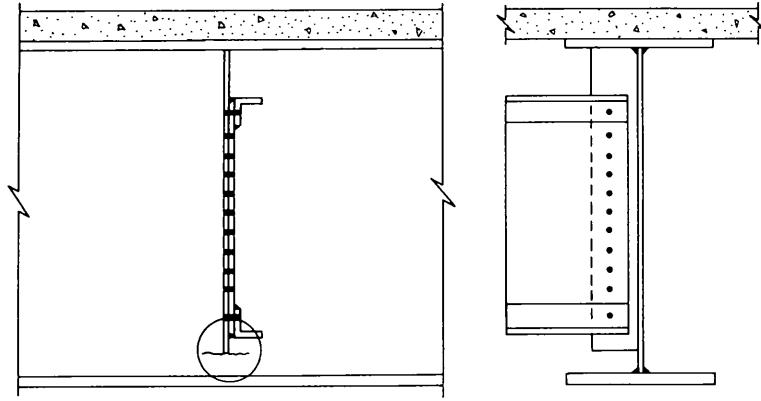
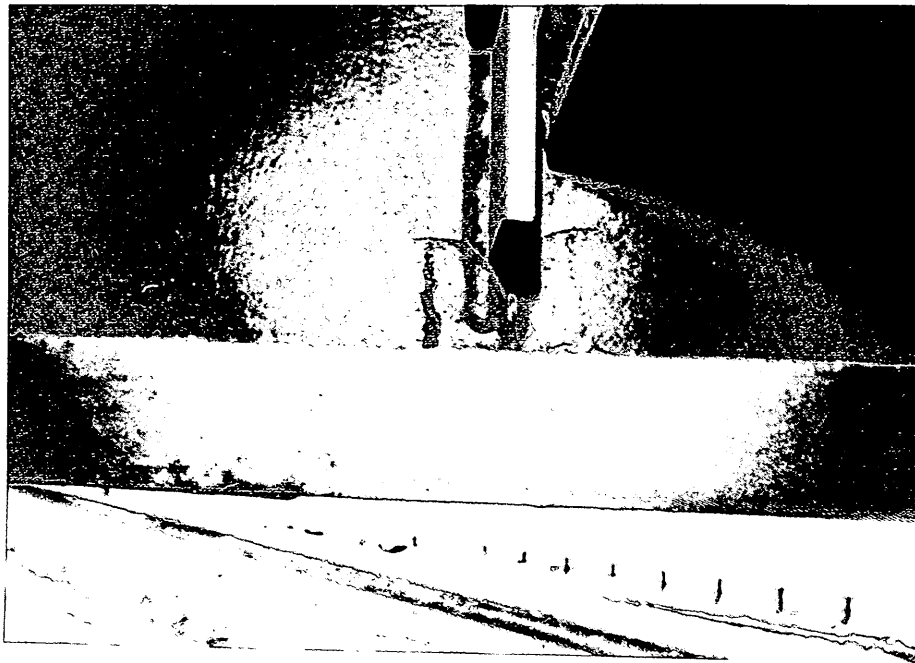

Fig. 4.28 Crack in Girder Web at Bottom of Floorbeam Connection (View from Outside)



(a)



(b)

Fig. 4.29 Crack at Unattached Lower End of Diaphragm Connection Plate in Skewed Bridge

down the surface. Severely skewed bridges with relatively heavy flanges should have the lower ends of diaphragm connection plates inspected frequently, if these connection plates are not attached to the bottom flange.

4.4.2 Ends of Diaphragm Connection Plates in Girder Bridges

All diaphragm connection plates should be positively attached to the girder flanges in order to resist the forces and deflections induced by the diaphragm members. If the attachment or detail condition is not adequate, fatigue cracks can develop at the end connection. One of these conditions is the insufficient fillet weld between the end of a connection plate and the girder flange. This weld must be able to endure the lateral forces from the diaphragm components. The fillet weld in the detail of Fig. 4.30 has cracked, and eventually will sever the diaphragm connection plate from the flange. A horizontal fatigue crack can then develop in the web plate because of the out-of-plane deflection, similar to those cases shown in Figs. 4.24 to 4.26.

Sometimes, the diaphragm components are connected to gusset plates which are welded to the vertical connection plates, as shown in Fig. 4.31. The ends of the groove weld between the gusset plate and the connection plate have a fatigue strength of category E, and there is an abrupt change in plate geometry with re-entrant corner at the top of the connection plates. Fatigue cracks developed in this region.

Unless these fatigue cracks are accompanied by movement and by oxide powder, their existence may not be obvious. Careful inspection from both sides of the diaphragm is necessary.

4.4.3 Box Girder Webs at Diaphragms

Webs of box girders at unattached ends of diaphragm connection plates are susceptible to the same kind of out-of-plane deflections and fatigue cracking which occur to webs of plate girders. While diaphragms in plate girder bridges are not required for the load carrying

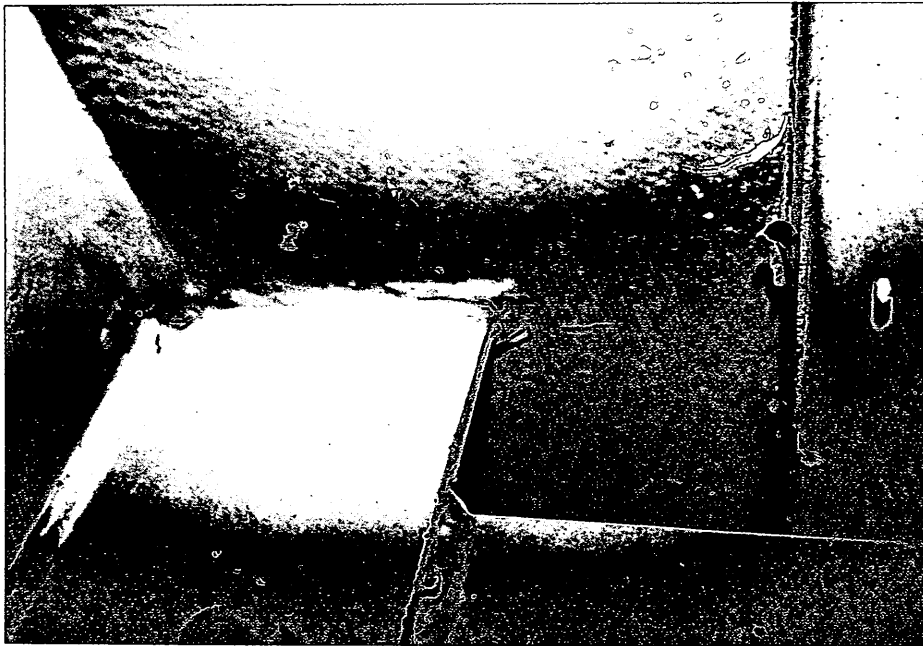
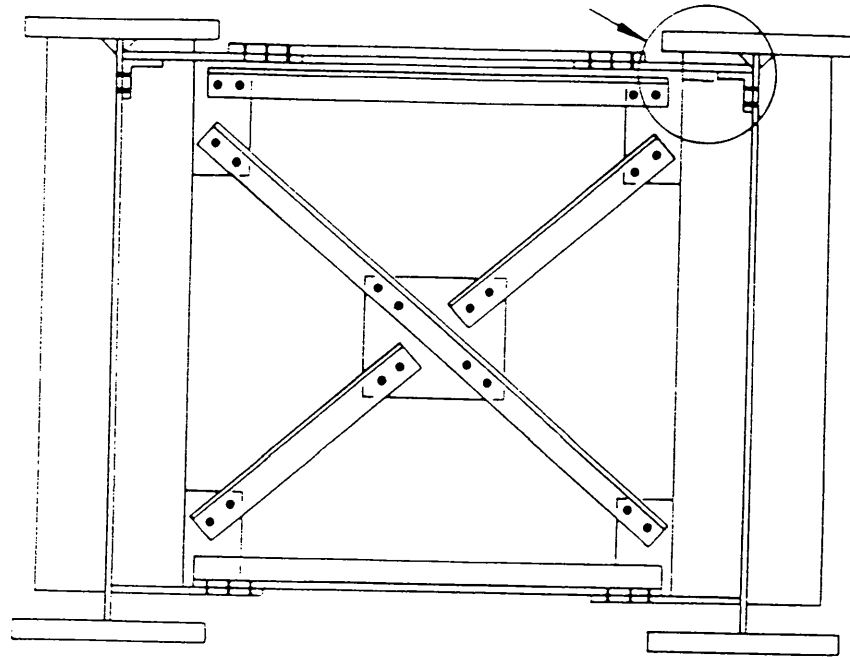

Fig. 4.30 Fatigue Crack in Weld between Flange and Diaphragm Connection Plate



(a)



(b)

Fig. 4.31 Crack in Diaphragm Connection Plate at Gusset

strength of the bridge, the diaphragm action in box girders is necessary for their strength and function. Therefore, higher forces in box girder diaphragm components can be expected and fatigue cracks in the web at the ends of unattached connection plates will occur at more diaphragms in box girder than in plate girder bridges.

Figure 4.32 shows the interior of a simple span rectangular box girder with k-diaphragms. The fatigue cracks occurred in the webs at the lower end of the diaphragm connection plates. Dye penetrant was applied to help inspection. Figure 4.33 shows a crack which was apparent without visual aid. The crack started at the end of the connection plate, propagated upward along the weld toe, and then turned horizontal into the web plate, in the typical pattern of these out-of-plane deflection induced cracks.

This type of crack has developed in box girders of rectangular or trapezoidal cross section with k-frame, or plate diaphragm. Curved boxes and box girders which are subjected to high torsional loads are more likely to develop this type of crack at diaphragm connection plates. Frequent inspection should be made if truck traffic volume is high.

Another region of web-diaphragm junction in box girders which has incurred displacement induced fatigue cracks is at partial depth diaphragms inside tie girder of tie arch bridges. A schematic is shown in Fig. 4.34. The diaphragms are usually in alignment with the floor beams, and the primary function is to resist deformation of the box section. However, the small, unstiffened regions of the webs do not have sufficient rigidity against lateral, out-of-plane deflection. The situation is analogous to that of webs at unattached ends of floor beam or diaphragm connection plates. Fatigue cracks can develop at the ends of the diaphragm plates. An example is shown in Fig. 4.35. The crack initiated from the weld between the diaphragm and the web. In this instance, the weld was undersized and the crack propagated upward along the weld toe on the diaphragm side. The crack which is shown in Fig. 4.36 grew through the weld and into the web, following the typical pattern. Also shown in Fig. 4.36 is a horizontal crack in the flange to web weld, exposed after removal of the backup bar. This

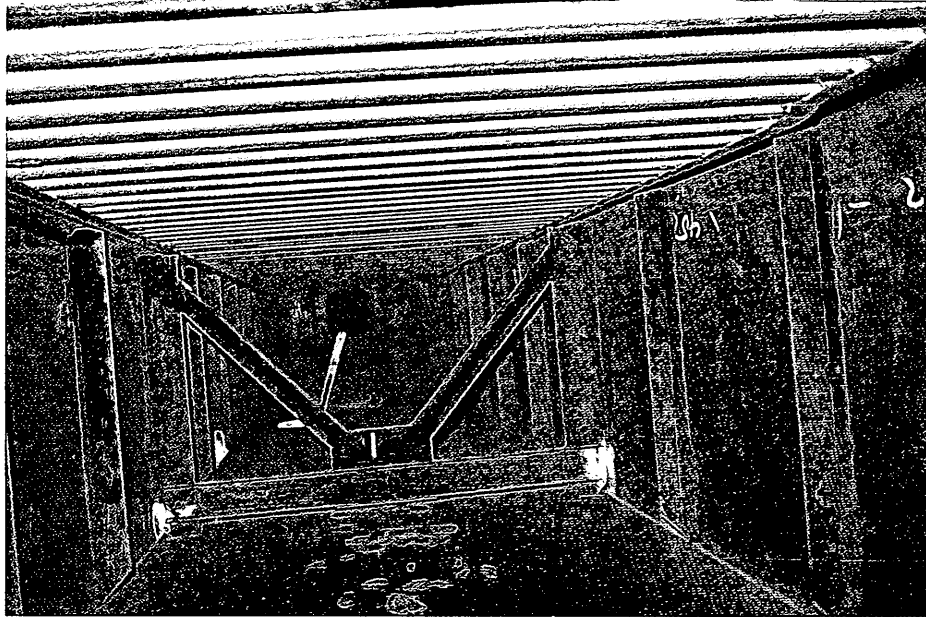

Fig. 4.32 K-Diaphragm in Box Girder

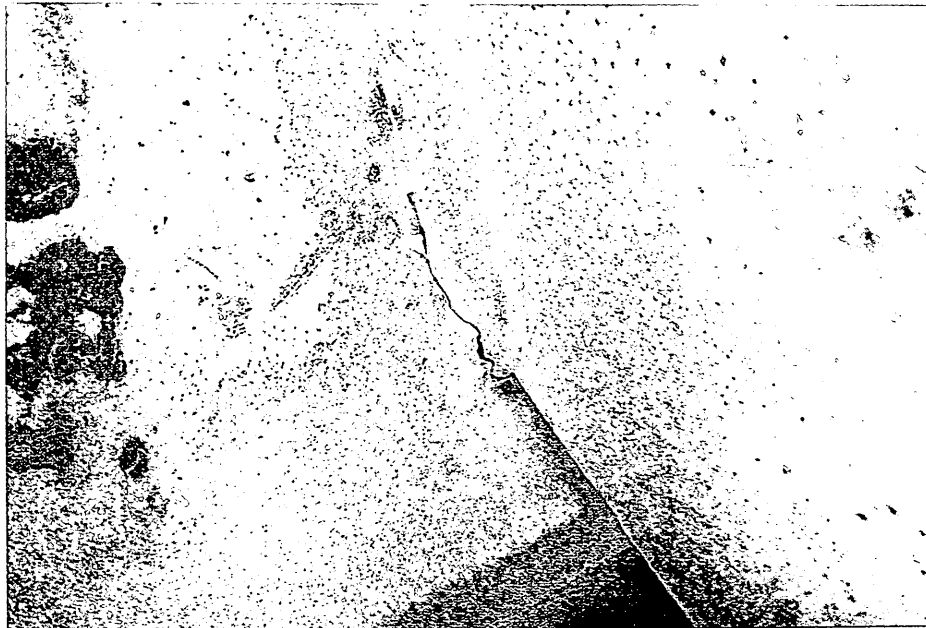

Fig. 4.33 Crack in Web at End of Diaphragm Connection Plate

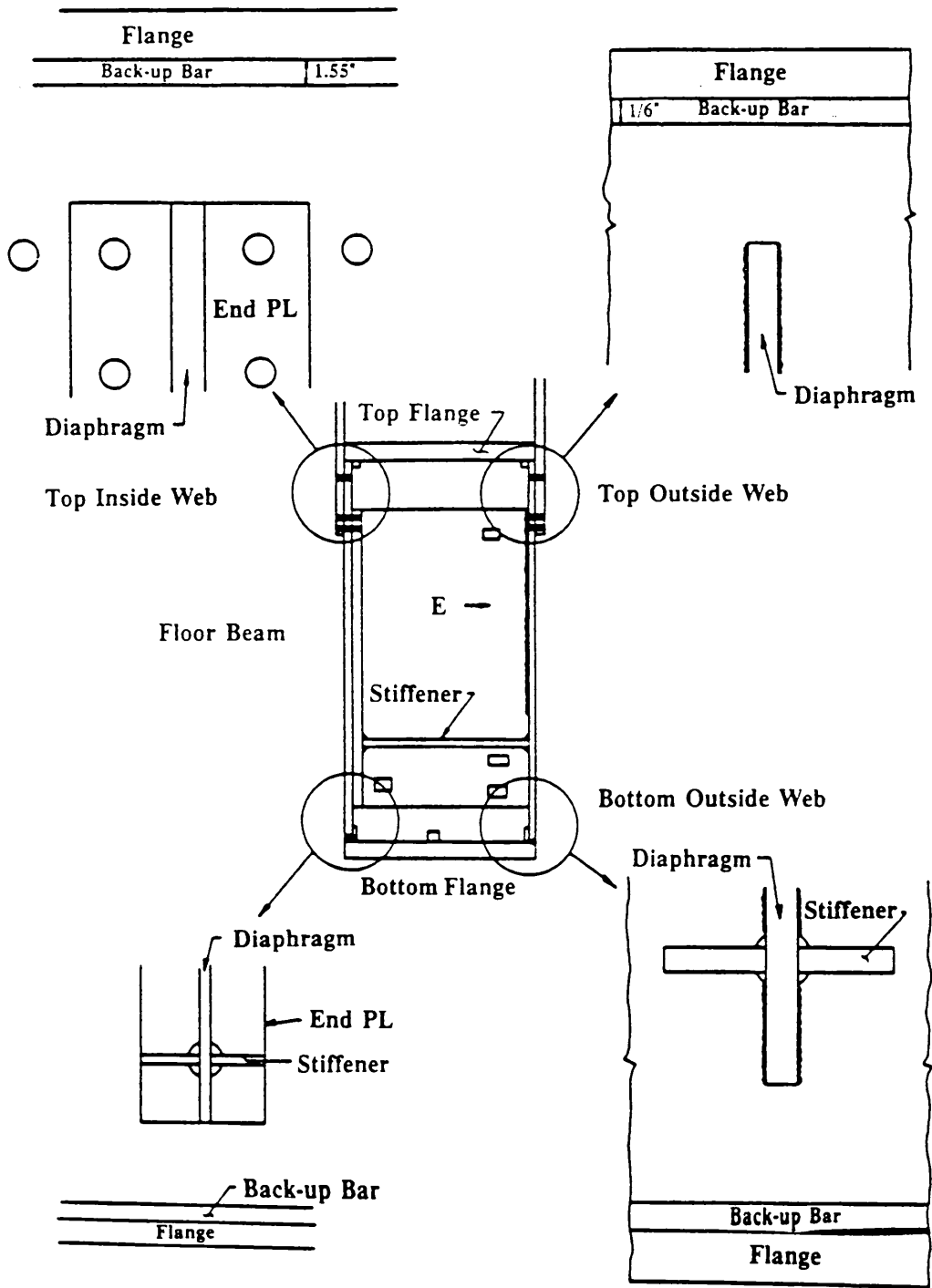

Fig. 4.34 Partial Depth Diaphragm inside Tie Girders



Fig. 4.35 Fatigue Crack at End of Diaphragm Plate



Fig. 4.36 Fatigue Cracks in Diaphragm Weld and in Flange-to-Web Weld

crack is analogous to those shown in Figs. 4.24 to 4.27, at the unattached ends of diaphragm connection plates.

The end of all partial depth diaphragms in box girders should be inspected.

4.4.4 Lateral Gussets on Plate Girder Webs at Floor Beam Connections

Many fatigue cracks resulting from out-of-plane deflection of girder webs have been detected in web plates at the junction of lateral bracing gussets and floor beam or diaphragm connection plates. A schematic of this detail is shown in Fig. 4.37. The unequal lateral forces from the bracing members introduce lateral deflection and twisting of the junction in the direction perpendicular to the web. If the gusset plate is not attached to the vertical connection plate, the web plate in the small horizontal gap between the gusset plate and the connection plate is subjected to relative out-of-plane displacement and development of fatigue cracking.

Figure 4.38 is an example of such a crack. It initiated at the end of the groove weld between the gusset and the web. (The gusset plate was about a foot above the bottom flange of the girder and backup bars were used for weldings, the gusset to the girder web). The crack propagated downward towards the flange and a hole had been drilled to arrest the crack.

Figure 4.39 shows another example of a crack in the gap between the lateral bracing gusset and the floor beam connection plate. In this case, the lateral bracing gusset was bolted to two tabs which were welded to the web on both sides of the connection plate. The crack was very small when detected and the photograph was taken. However, on the opposite side of the web plate, at the elevation of the gusset and this small crack, a crack more than an inch long was detected along the weld toe of the vertical fillet weld which joins the web and the fascia transverse stiffener in alignment with the floor beam. The crack is shown in Fig. 3.2. This situation of staggered cracks on opposite surfaces of a web plate in a small gap is typical of out-of-plane deflection induced cracks at lateral gusset to floor beam connection details. (It

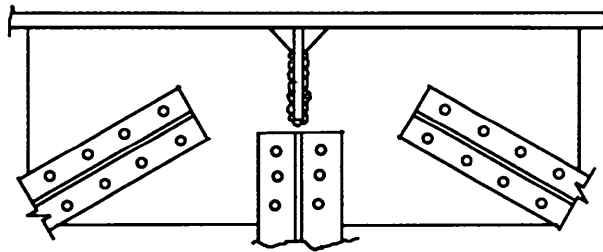
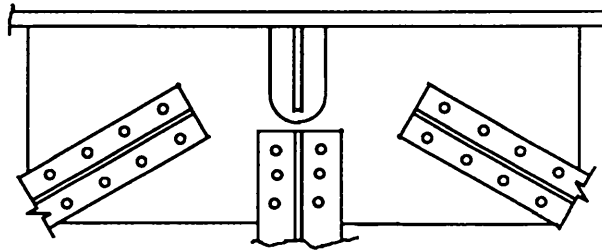

Fig. 4.37 Lateral Bracing Gusset at Floor Beam or Diaphragm Connection Plate

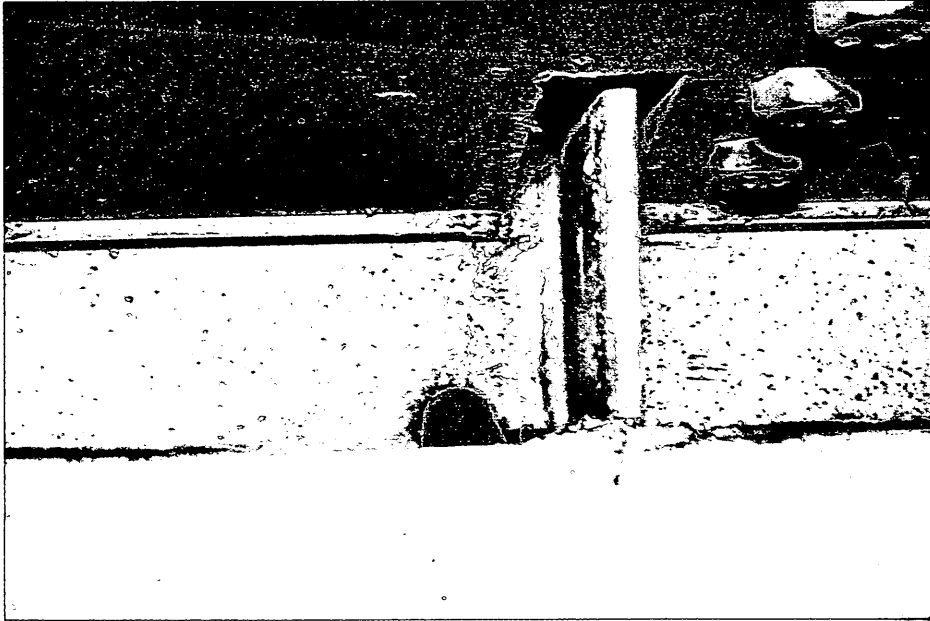

Fig. 4.38 Fatigue Crack at Lateral Bracing Gusset Plate Gap



Fig. 4.39 Crack in Gap Between Lateral Bracing Gusset and Floor Beam Connection Plate



Fig. 4.40 Crack in Weld at End of Lateral Bracing Gusset

is comparable to the situation at floor beam and diaphragm connection plate to girder flange junctions). Careful inspection of both surfaces of web plates in these details is necessary.

At the far ends of a horizontal gusset attached to the web for lateral bracing members (the ends away from the floor beam connection plate), the welded detail has category E fatigue strength. With the out-of-plane deflection and twisting of the junction, the web is subjected to plate bending stresses which add to the primary stresses in the girder web. Fatigue cracks may develop at the weld toe on the web surface. An example is given as Fig. 4.40. This crack was detected very early in its growth. Although the existence of this type of crack has not been observed often, inspection of this detail is advisable.

4.4.5 Floor Beam and Cantilever Bracket Connection to Girders

In girder and floor beam bridge systems where the stringers are placed above the floor beam and the top flanges of the girders are not embedded in the deck slab, serious relative deflections in the direction of the girder could occur at floor beam and outrigger cantilever bracket connections to the plate girders. Fatigue cracks have been detected in the webs of the floor beams and the cantilever brackets. A schematic is shown in Fig. 4.41. The situation is not unique to welded floor beams but occurs also in rolled and built-up members.

A fatigue crack in the web of a welded floor beam in a continuous girder bridge is shown in Fig. 4.42. The tie plate connecting the top flanges of the floor beam and the cantilever bracket is not attached to the top flange of the girder. The relative movement between the girder and floor beam-cantilever bracket flanges induced out-of-plane deflection of the floor beam web and caused the fatigue crack. Similar cracks were detected at a number of similar locations, both in the floor beam web and in the web of the cantilever bracket of this bridge. In another bridge which has rolled floor beams and built-up cantilever brackets, the same kind of out-of-plane deflections caused fatigue cracks in the web plate of both the floor beams and the cantilever brackets. Examples are shown in Figs. 4.43 and 4.44. In Fig. 4.43, the oxide and bleeding are clear signs of cracking; along the flange of the rolled beam of Fig. 4.44, the

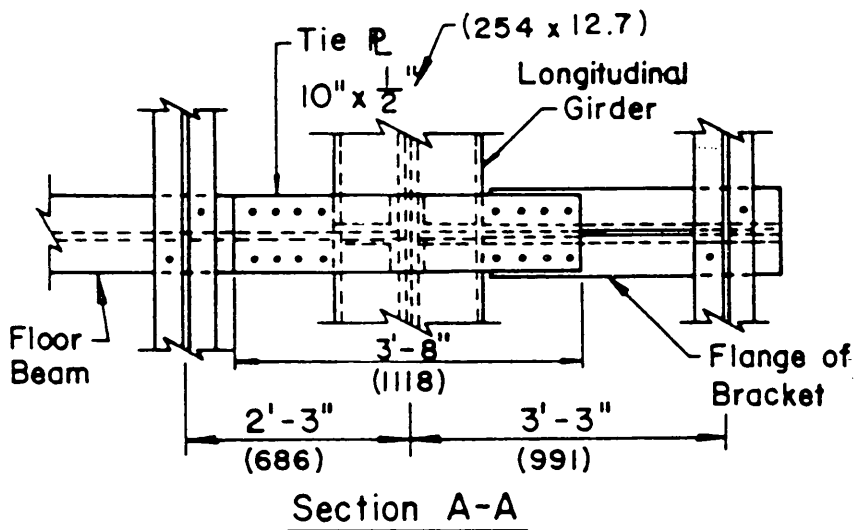
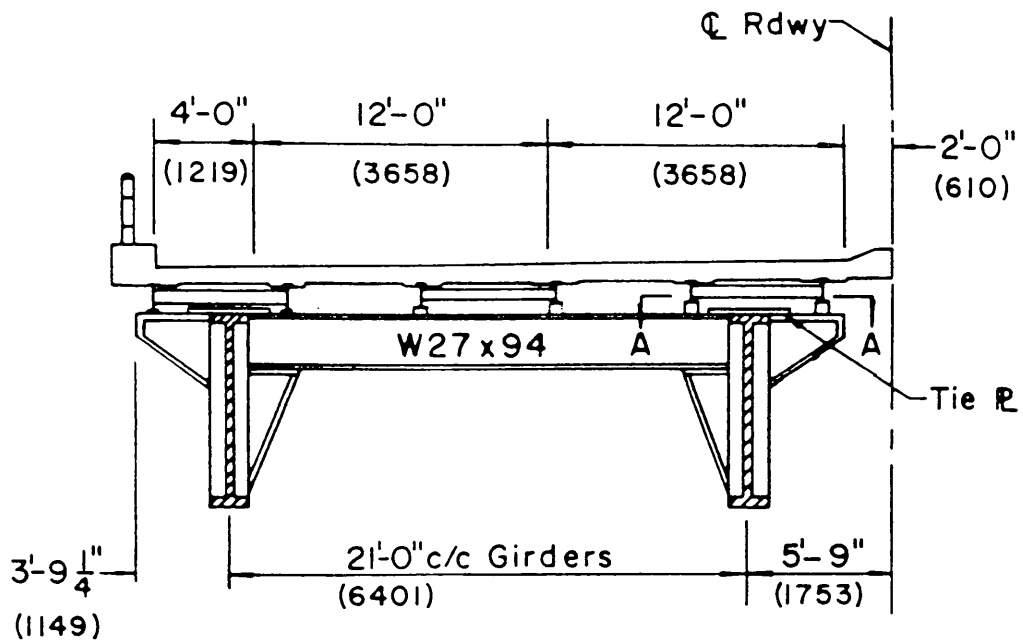

Fig. 4.41 Floor Beam-Cantilever Bracket Tie Plate not Connected to Girder Top -- Flange

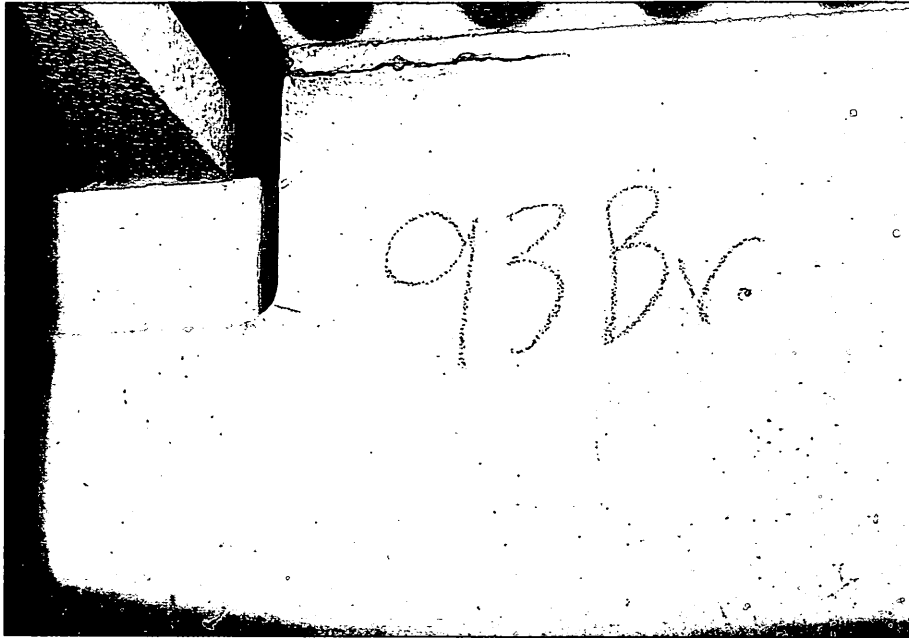

Fig. 4.42 Fatigue Cracks in Floor Beam Web at Connection to Girder

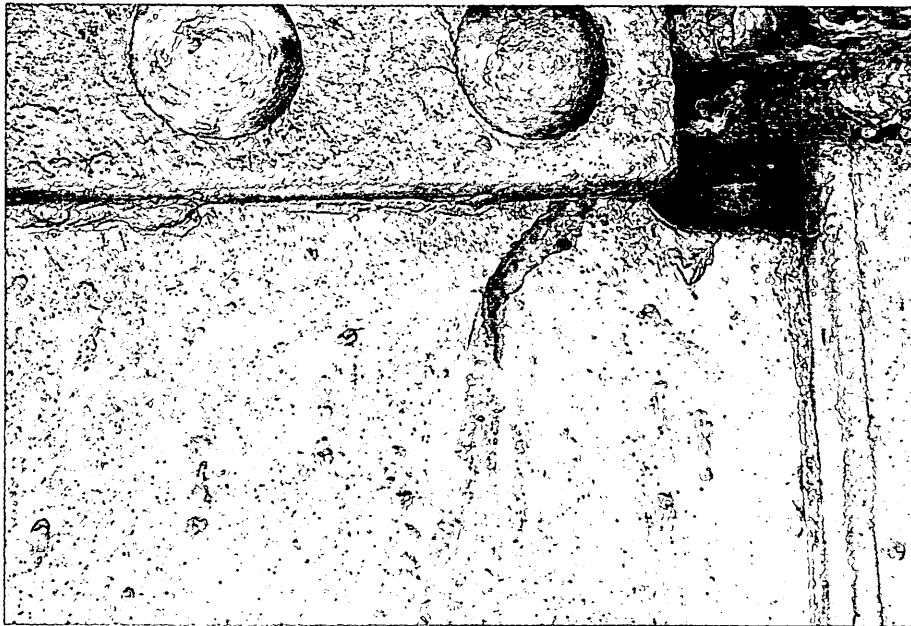

Fig. 4.43 Crack in Web of Cantilever Bracket



Fig. 4.44 Crack in Floor Beam Web at Connection to Girder

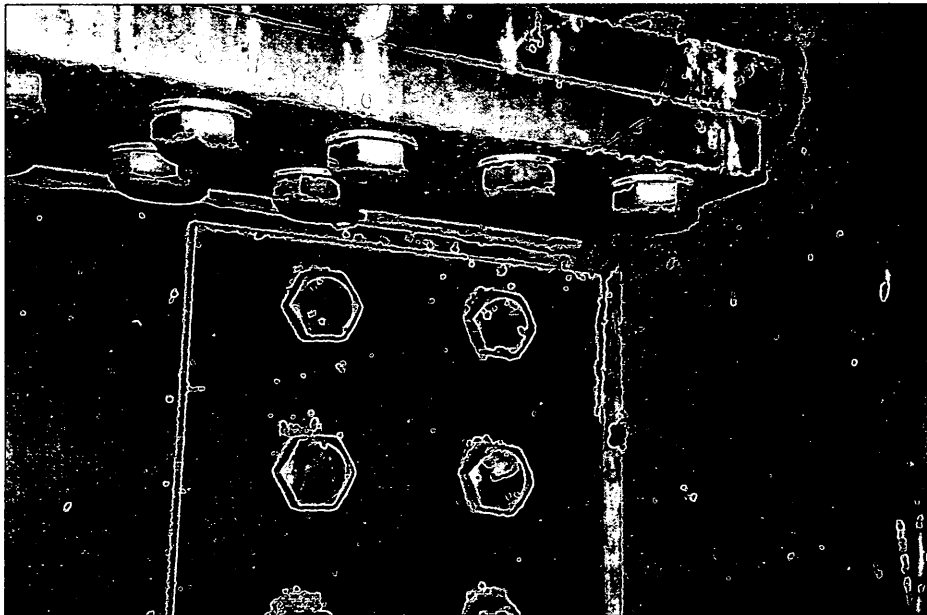

Fig. 4.45 Crack in Web of Floor Beam and in Floor Beam Connection Plate

paint film is broken but the horizontal crack is not obvious without careful examination.

Figure 4.45 shows a horizontal crack in the web of a floor beam of another welded bridge. The tie plate connecting the top flange of the floor beam to the top flange of the cantilever bracket passes through a slot in the girder web but is not attached to it. The relative deflection between the floor beam flange and the girder, in the direction of the girder, induces out-of-plane deflection of the floor beam web and causes the horizontal crack. A vertical crack has also developed in the floor beam connection plate along the toe of the fillet weld. These are typical cracks in small gaps at connections. In bridges with deep girders and floor beams, such cracks have also been detected in small gaps at boundaries of floor beam access holes at catwalks and at ends of local stiffeners on web plate which stiffen the web plate and concentrate the out-of-plane deflection in the small gaps.

Displacement induced fatigue cracks have also developed in the webs of many floor beams at connections to tied arch girders and to truss bridge lower chord panel points when the stringers are placed above the floor beams. The webs of these floor beams at the connections and adjacent to flanges and stiffeners needs to be inspected routinely.

4.4.6 Pin-Connected Hanger Plates and Welded Pin Plates

Pin-connected hanger plates and welded pin plates in girder bridges are also susceptible to fatigue cracking because of transverse displacement and forces which are not intended for the components. Figure 4.46 shows the schematic of these details. (It appears that most of the welded pin plates in bridges have been retrofitted).

The in-plane transverse displacement and forces usually result from corrosion of the joints and frozen pins. When the pin connections are not free to rotate, the pin plate or the hanger plate is then subjected to transverse bending. Fatigue cracks could develop in the pin plate of Fig. 4.46 at the ends of the welds, which are of Category E or E' in fatigue strength. The hanger plate in the sketch has a much higher fatigue strength but the magnitude of bending

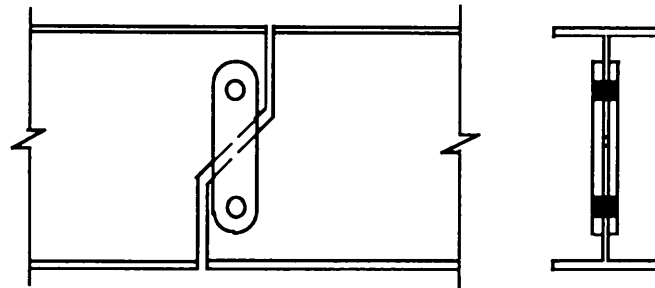

(a)

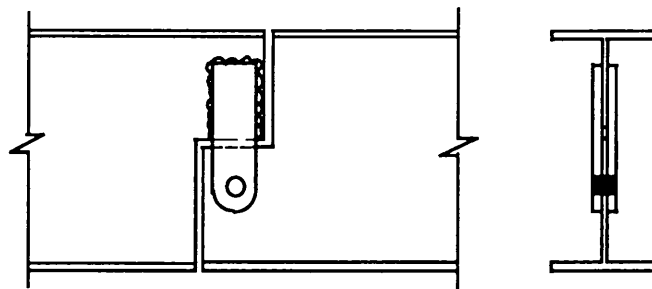

(b)

Fig. 4.46 Schematic of Hanger Plate and Welded Pin Plate

to the girder web because of corrosion. Fatigue cracks could initiate from the edge of the plate and propagate through the width of the plate. An example is shown in Fig. 4.47.

When corrosion in the pin assemblage is severe, the expansion of the corrosion product could also generate very high forces perpendicular to the hanger plate surface, in addition to freezing of the pin. This perpendicular force could cause displacement within the assemblage, fatigue damage of its components, and failure of the hanger system as it was reported of the Mianus River Bridge⁽²¹⁾.

Fatigue cracks in hanger plates can be detected by oxide decoloring and cracking of paint film. Inspection of fatigue cracks in a pin assemblage is very difficult without removal of the pin cap. The existence of corrosion products would suggest that cleaning and inspection should be conducted.

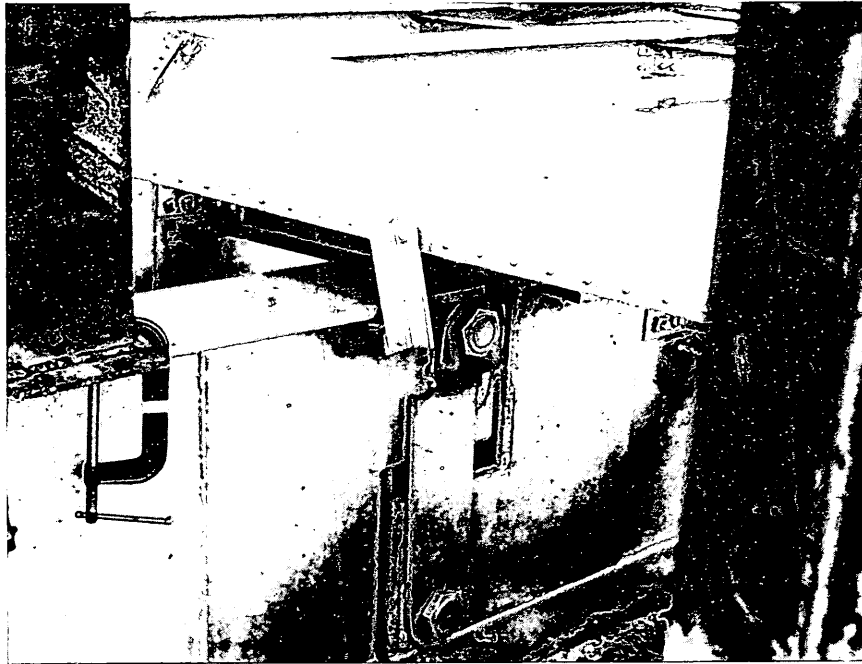

Fig. 4.47 Broken Hanger Plate

CHAPTER 5. FATIGUE DAMAGE IN RIVETED AND BOLTED BRIDGE DETAILS

5.1 Fatigue Strength of Riveted and Bolted Members and Connections

The fatigue strength of riveted members is defined by category C and category D AASHTO design fatigue strength curves. Test data from full scale members taken from riveted bridge structures suggest that category D provides a lower bound estimate for crack detection and that category C defines the fatigue strength of the riveted members. These data are shown in Fig. 5.1 with some of the AASHTO design fatigue strength curves.

As it is the situation with welded bridge members, fatigue damages of riveted bridge members occurred mostly at the connections, only occasionally at the main part of the members between connections. Limited test data suggest category D fatigue strength as the reference for riveted joints or connections, and category B for high strength bolted connections.

Historically, riveted bridges are much older than welded bridges, and bolted connections became prevalent in the 1960's. For riveted bridges on major highways, the members and connections most likely have been subjected to a large number of load cycles. Therefore, inspection of riveted members and connections in bridges with high truck traffic volume is necessary. Those details with known failures in the past should be examined carefully.

In general, the locations where fatigue cracks have been detected in riveted bridges are similar to those in welded bridges. A listing of probable locations of fatigue cracks is given as Appendix B. Some examples of fatigue damage in riveted and bolted bridge details are given in the following sections.

5.2 Fatigue Damage at End Connections

5.2.1 Cracking (Prying) of Rivets and Bolts

Simple stringer-to-floor beam and floor beam-to-girder connections resist bending moments in addition to the vertical shear forces acting on the joint. Furthermore, the direct contact and composite action between the bridge deck and the stringer or floor beam cause

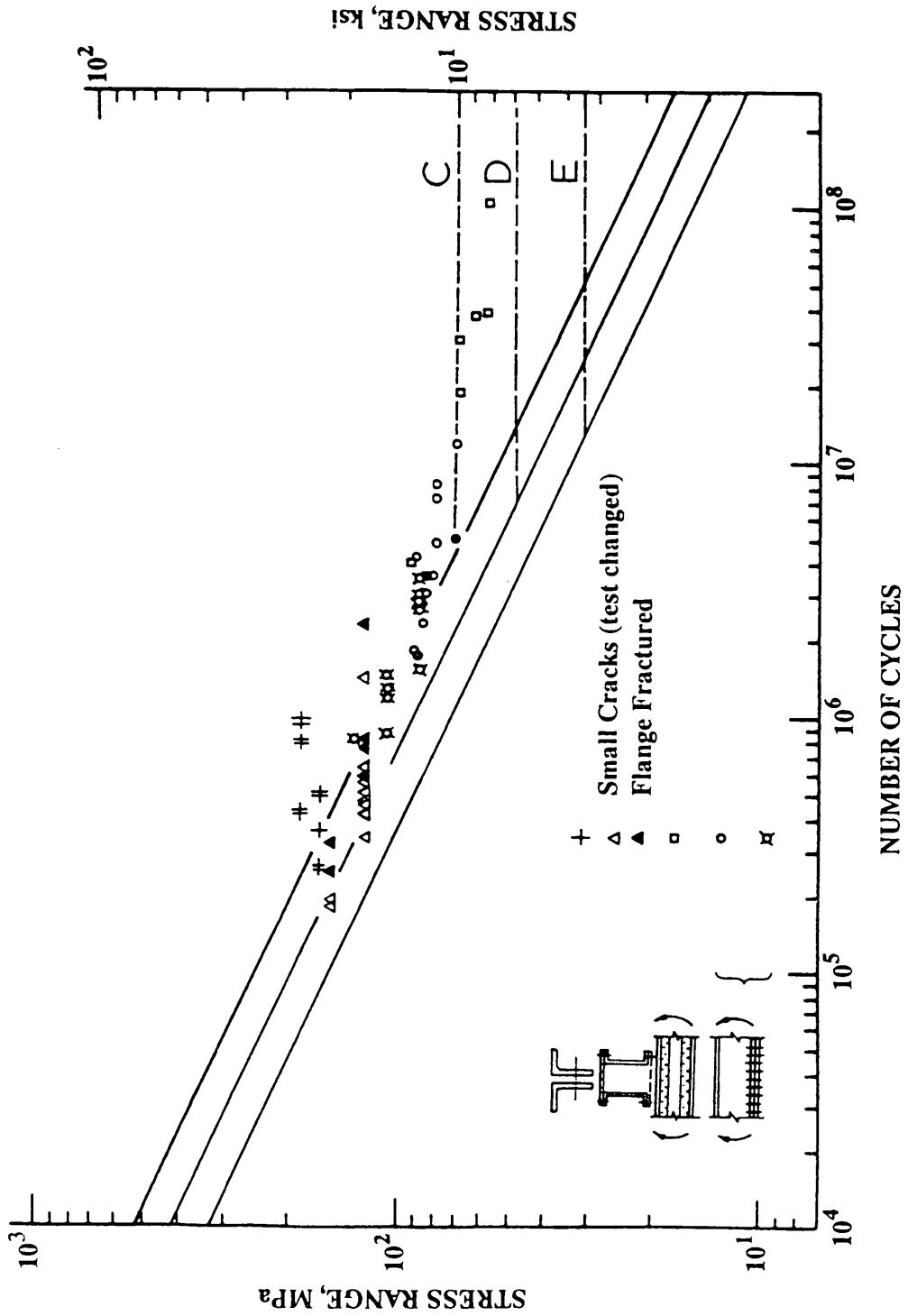

Fig. 5.1 Fatigue Test Date for Full Scale Riveted Bridge Members

the bending axis to be close to the deck. The rivets or bolts farthest from the axis of bending are subjected to the highest forces. Cracking off rivet heads or bolt heads or units joining the outstanding legs of end connection angles to web plates have occurred often because of the prying action.

Fig. 5.2 shows a simple stringer-to-floor beam connection. The lowest rivet was subjected to axial forces and bending and cracked under the rivet head. Oxide powder around the rivet head or below the rivet, a small gap between the rivet head and the surface of the angle, and the dull sound when a rivet head is tapped, are signs of such cracks. Deeper stringers and floorbeams with this type of simple shear connections are more likely to develop cracked rivets or bolts. Missing bolts at the lower end of a connection on a floor beam web is shown in Fig. 5.3. The bolts have broken and fell out of the joint.

5.2.2 Connection Angle Failures

The bending moment resisted by so-called simple shear connections at beam or girder ends can induce fatigue cracking in the connection angles instead of the rivets or bolts. Figure 5.4 shows a crack in a connection angle removed from a stringer to floor beam connecting of a bridge. The angle is removed for study after the detection of the crack. It occurred at the lower end of the connection, along the fillet of the angle, and propagated upward. A small crack was also detected along the first line of the rivet. This condition of two parallel cracks in a leg indicates the out-of-plane bending of the angle legs, and is analogous to the out-of-plane deflection induced cracks in girder webs. If the connection angles are relatively light and the gage distance is small between the first line of rivets (or bolts) and the heel of the angle, fatigue cracks could develop in the angles. Careful inspection should be made when this geometrical condition exists.

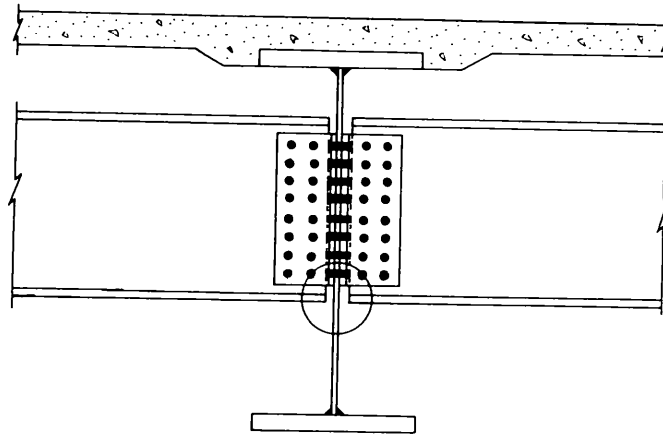

(a)



(b)

Fig. 5.2 Cracking of Rivet at Stringer-Floor Beam Connection

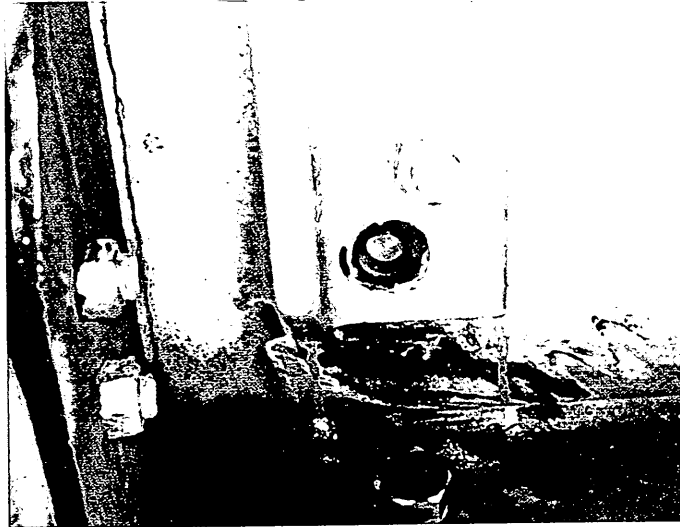

Fig. 5.3 Missing Bolt at End of Angle

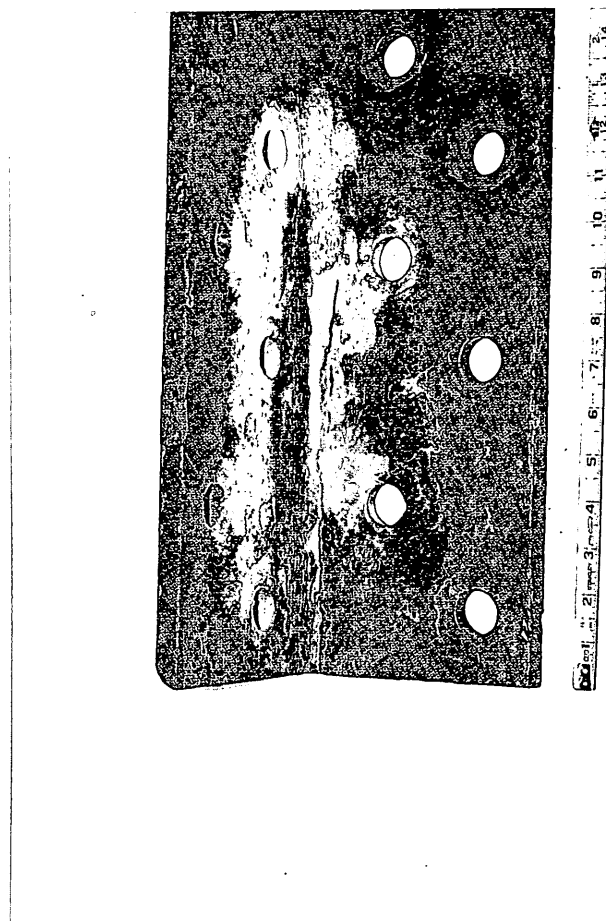

Fig. 5.4 Fatigue Crack at End of Connection Angle

The cracking of connection angles can also develop in the leg parallel to the end of the beam. Figure 5.5 is a close-up view of the lower end of a connection angle between a main girder and the cross girder of a bent. The crack developed along the bolt heads in the leg on the girder web. A similar crack existed in the companion connection angle on the opposite side of the girder web. Inspection from below the girder at its end confirmed the cracks. A photograph of this view is shown as Fig. 5.6.

Most of the detected cracks in connection angles were in the outstanding leg which is perpendicular to the floor beam or girder being connected. The cause of these cracks and that of prying the rivet or bolt heads are the same: the beam end moment. The ends of connection angles of deep, simple shear joints at stringer, floor beam and longitudinal girders should be carefully inspected.

5.2.3 Girder Webs at Floor Beam End Connections

Fatigue cracks have also been detected in webs of riveted girders at floor beam ends. Figure 5.7 shows the arrangement of component members and the crack in one bridge. The crack occurred in the web and propagated almost vertically between a seat angle for the floor beam and a transverse stiffener of the web. The crack was apparent by observation.

The development of the crack resulted from the floor beam end moment and the out-of-plane bending of the small segment of unstiffened web between the seat angle and the stiffener. The relative out-of-plane bending of the web plate was more severe in the horizontal direction, thus the crack grew vertically.

Any unstiffened web plate between two lines of rivets at the end connection of beams needs to be examined for fatigue cracks if the beam is relatively deep and the bridge is subjected to frequent heavy loads.

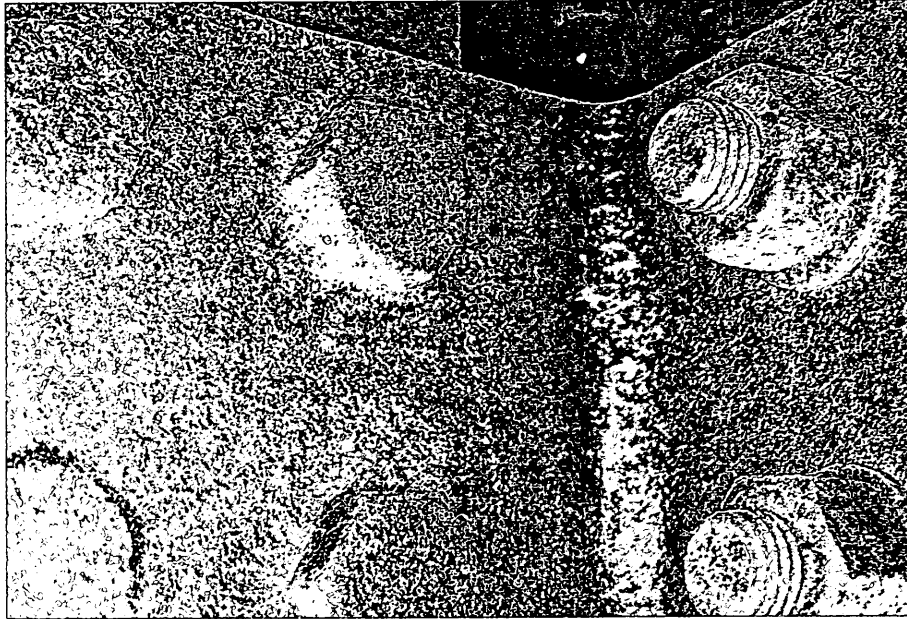

Fig. 5.5 Crack in Longitudinal Girder-Cross Girder Connection Angle

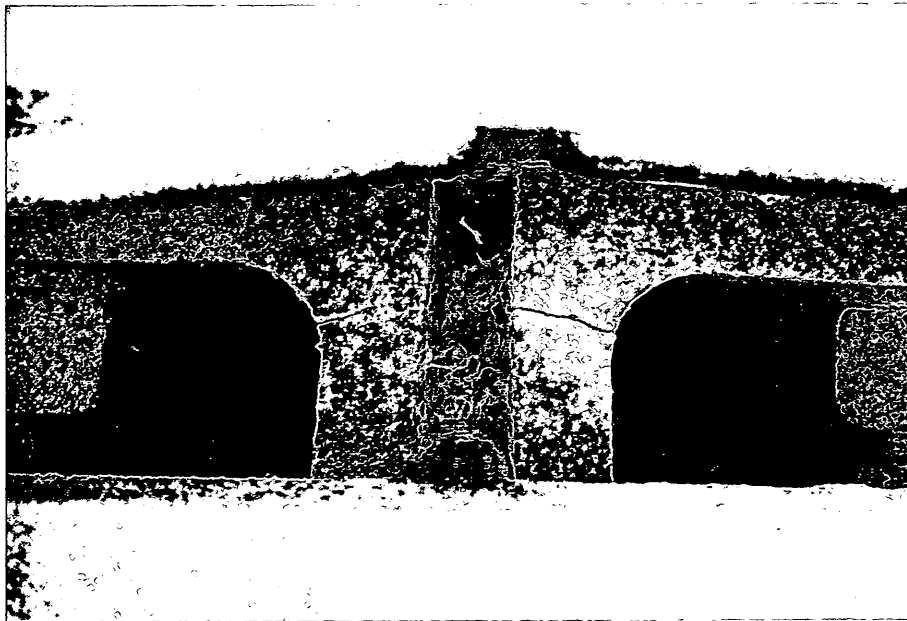
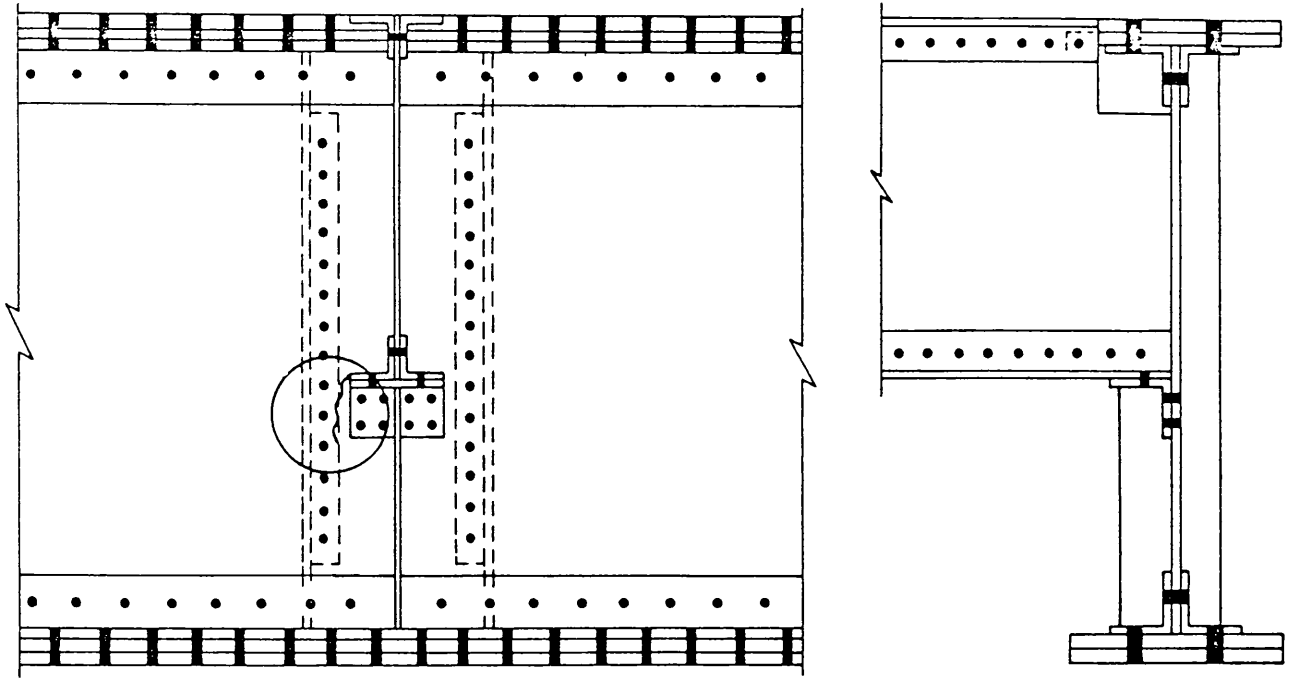
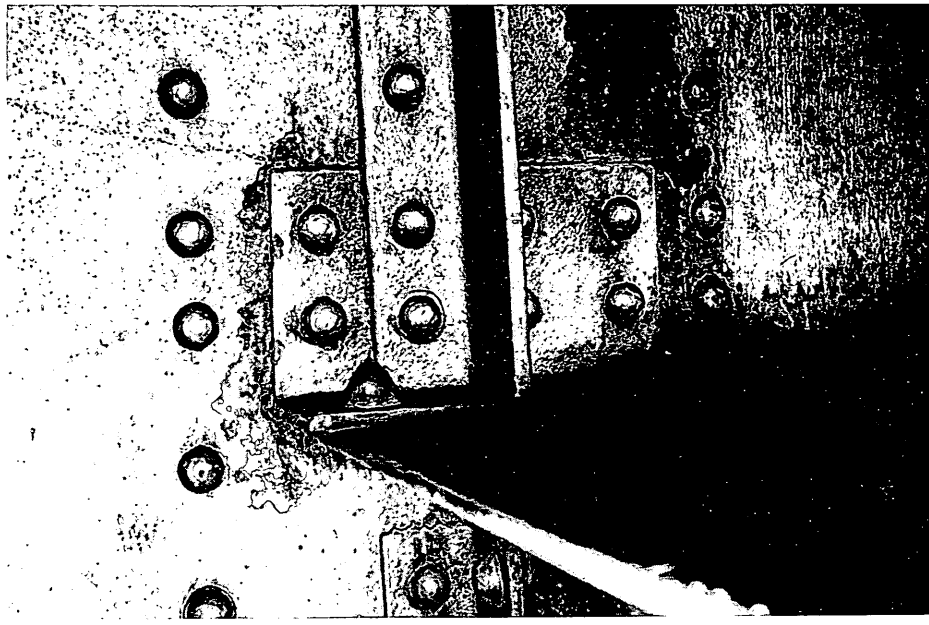

Fig. 5.6 Cross-Sectional View of Connection Angle with Fatigue Cracks



(a)



(b)

Fig. 5.7 Fatigue Cracks in Web of Riveted Girder at end of Floor Beam

5.3 Floor Beam and Cantilever Bracket Connections to Girders

Similar to the development of fatigue cracks in floor beam webs at bolted connections of welded floor beams and girders (see section 4.4.5), fatigue cracks also have developed at riveted connections of riveted, rolled, and welded beams. The relative displacement between the floor beams and girders, in the direction of the girder, induced local out-of-plane deflection and fatigue crack in the floor beam web, as shown in Fig. 5.8 (and in Figs. 4.42 and 4.43). This out-of-plane deflection of the floor beam web and cantilever bracket web can also cause prying on the rivet heads at the connection angles. Figure 5.9 is an example of this condition at a floor beam end connection. Bleeding (oxide) from under the rivet head strongly suggests that a fatigue crack has developed in the rivet under the rivet head.

Figure 5.10 is another example of fatigue cracking in floor beam web at its riveted connection to a girder. In this case, the floor beam is a welded member connected to the tie girder of a tied arch. There is no direct connection of the floor beam flange to the tie girder. The relative displacement between the floor beam and the girder is concentrated in the small gap above the connection angle, and caused the fatigue crack. It propagated horizontally along the weld, and is obvious to naked eyes.

When the tie plate connecting the floor beam and cantilever bracket top flanges is also attached to the girder top flange, the relative displacement between the girder and the floor beam and cantilever bracket is primarily resisted by the tie plate. This condition can cause significant horizontal bending of the tie plate and high stresses at its edges and at rivet or bolt holes. Fatigue cracks have been detected at these locations. Figure 5.11 shows a crack in a tie plate that initiated at its edge from a small tack weld. All tie plates which connect the floor beam and cantilever bracket flanges to the girder flange must be inspected if these components are not embedded in the bridge deck.

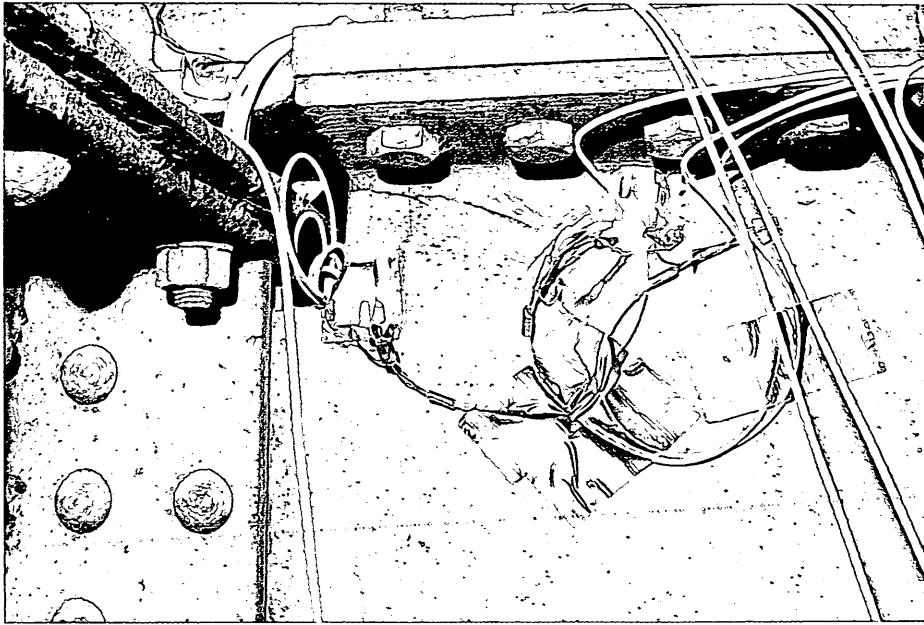

Fig. 5.8 Crack in Floor Beam Web at Riveted Connection to Girder

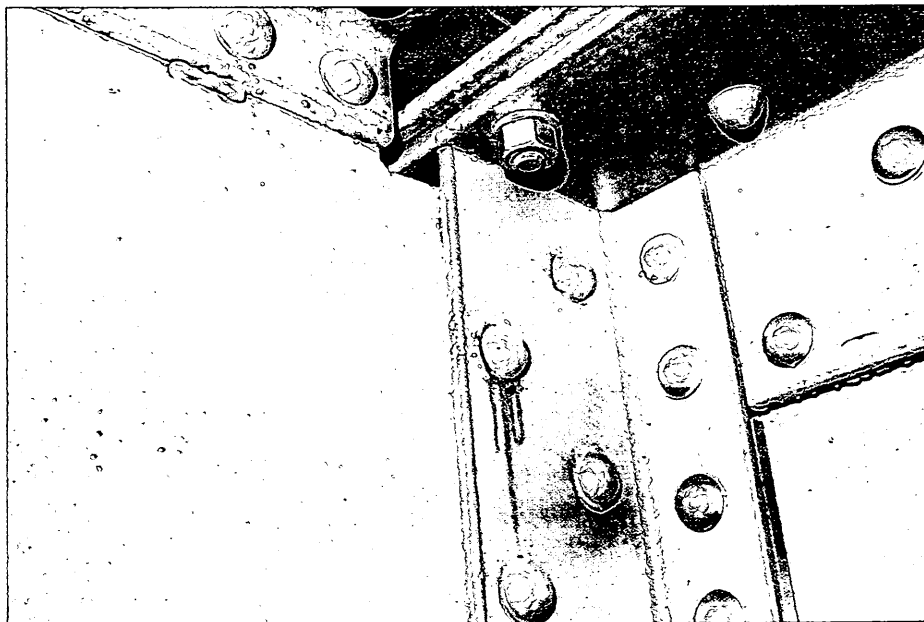

Fig. 5.9 Bleeding from Rivet Suggesting Cracking Underneath Rivet Head

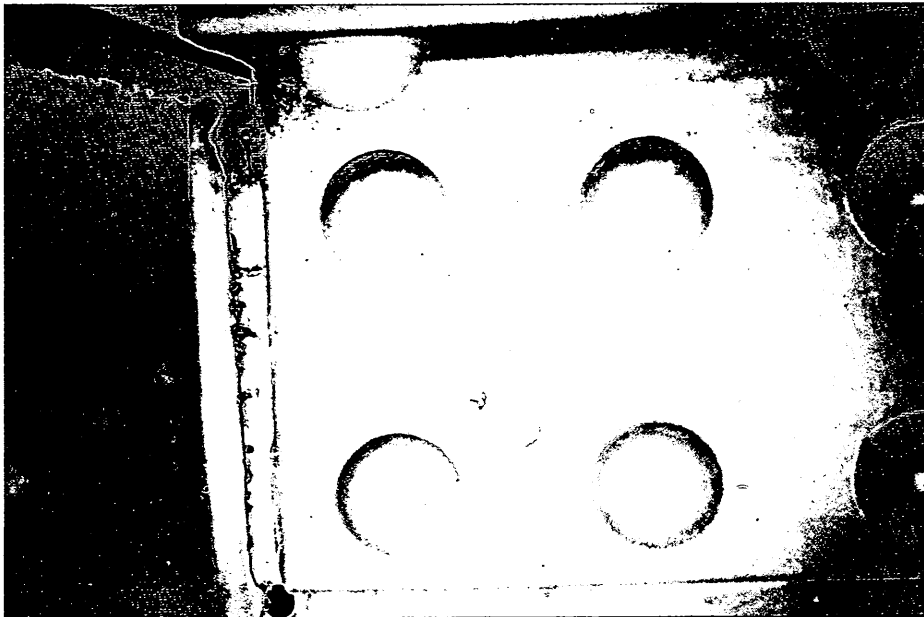
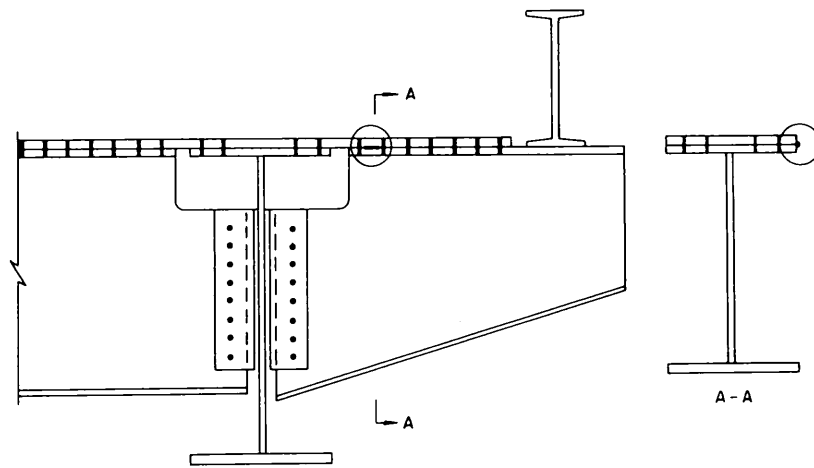

Fig. 5.10 Cracking of Floor Beam Web at Connection to Tie Girder



(a)



(b)

Fig. 5.11 Crack in Tie Plate Connected to Girder Flange

5.4 Diaphragm Connections to Girders

Diaphragms in riveted bridges are usually connected to girders by connection angles, as illustrated in Fig. 5.12a. The connection angles normally extend over the vertical legs of the flange angles. Differential deflection of the girders introduces diaphragm forces which pull or push the diaphragm members against the connection angles. The legs of these angles parallel to the girder web are subjected to out-of-plane deflection. Fatigue cracks often develop, either in the connection angle in the gap between the heel and the line of rivet, or in the rivets under the head. Figure 5.12b shows a vertical crack in a connection angle, along the rivet line. Oxide decoloring of the paint and fallen oxide powder on the flange angle are signs of the crack.

If the gage distance between the rivets and the heel of the connection angle is small, or if the connection angle is not lapping the vertical leg of the flange angle leaving a small gap in between, fatigue cracks can develop from the diaphragm forces. Careful inspection of the connection should be made.

5.5 Truss Hangers and Eyebars

A large number of riveted bridges have pin-connected lower chords, diagonal eyebars and vertical hangers. The hangers are often riveted built-up members if the bridge is long and has suspended spans. The primary cause of fatigue damage in these tension members has been corrosion and freezing of the pin connection, analogous to the condition of hanger plates in welded bridge girders (see section 4.4.6). Frozen pin connections prevent the hangers and eyebars from rotating and introduce bending in these members. Fatigue cracks may develop at rivet holes or at other points of high stress concentration.

An example of fatigue cracks in truss hangers is shown in Fig. 5.13. The upper pin joint of this hanger in the deck truss bridge was corroded, as were many other similar joints. Two fatigue cracks in the web of the member are visible in this figure, and one of these is shown in

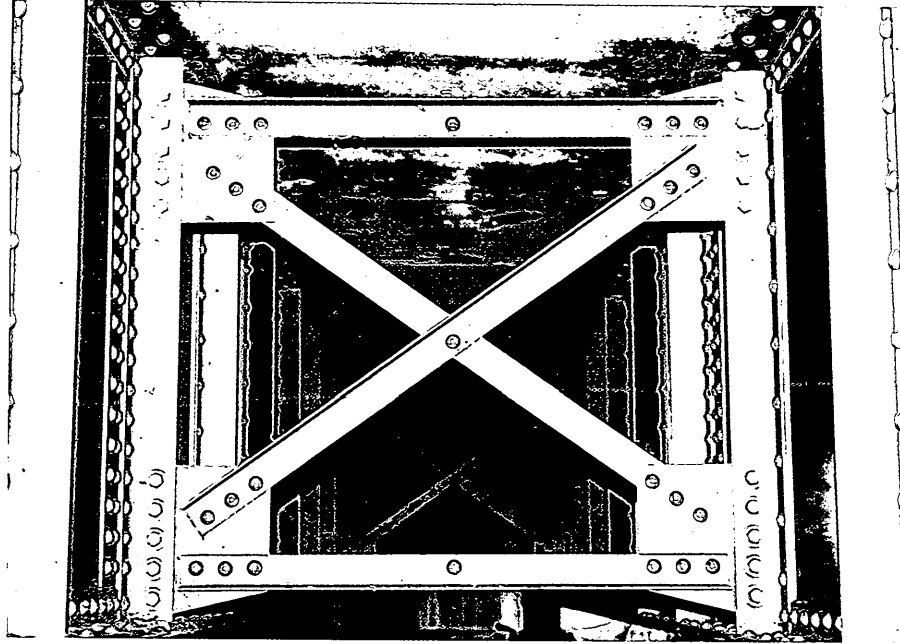

(a)

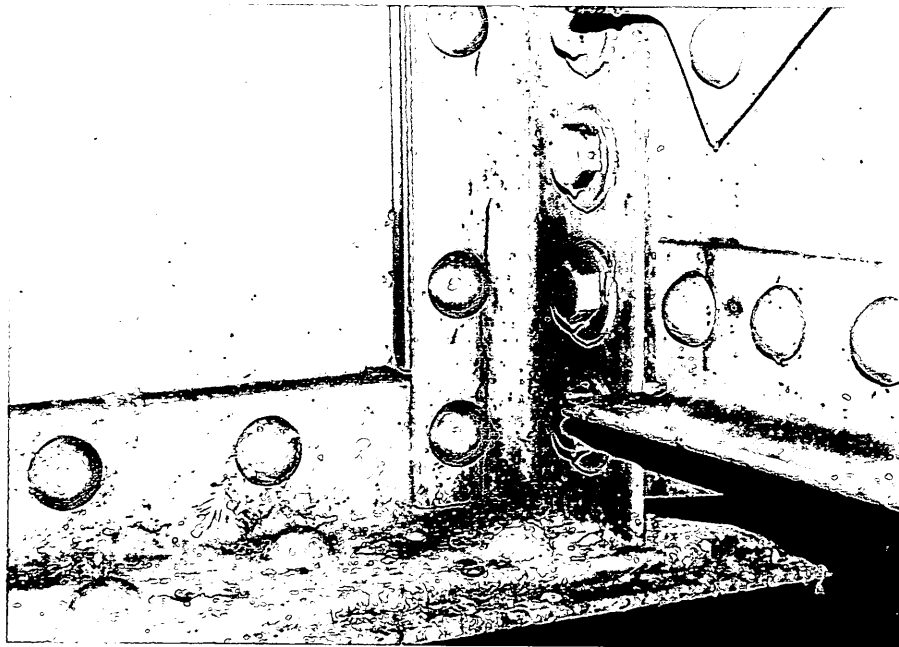

(b)

Fig. 5.12 Vertical Crack in Diaphragm Connection Angle

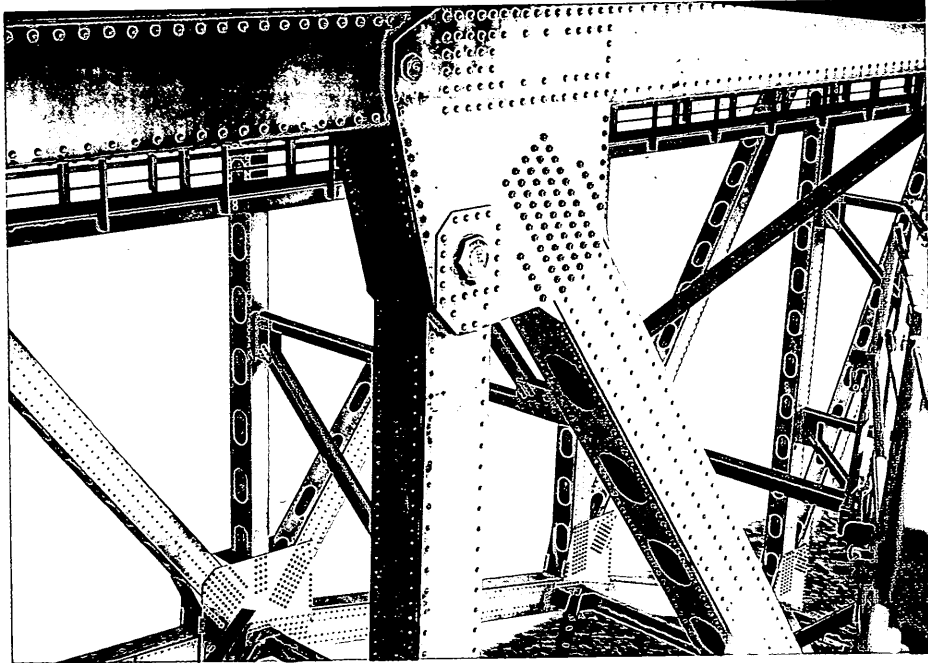

(a)



(b)

Fig. 5.13 Fatigue Cracks in Truss Hanger

detail for examination. The crack extends from a rivet to the edge of the member on one side and towards the middle of the web on the other. (A hole has been drilled at the crack tip to arrest the crack growth). Visual detection of this crack, and the shorter crack ten rivets below, was not difficult.

Figure 5.14 shows the arrangement of a riveted built-up link and an anchoring eyebar at the end of a suspension bridge. This and other riveted links are pin-connected to the bridge ends and transmit the uplifting forces at the bridge ends to the anchoring eyebars through the pin connections. The lower end of each eyebar is embedded in the concrete pier. Corrosion has restricted rotation of the joints as well as consumed some material of the eyebars at the point of embedment. A fatigue crack developed at the corroded region in one of the anchoring eyebars and resulted in fracture of the eyebar.

All pin-connected hangers and eyebars at locations where the pin connection appears to have frozen from corrosion, particularly large vertical hangers of suspended trusses, should be inspected for fatigue damage.

5.6 Tack Welds on Riveted Members

Tack welds exist in a large number of riveted structures. Examples can be seen in Fig. 5.8, 5.9, 5.11 and 5.12. Most of these tack welds were placed between components for the purpose of positioning and alignment before riveting. However, the deposit of these tack welds, which is usually unregulated and uninspected, creates weld defects and residual stresses. This condition can reduce the fatigue strength of the riveted member and lead to the development of fatigue cracks if the live load stresses are high enough.

The fatigue crack in the tie plate shown in Fig. 5.11 initiated at a tack weld at the edge of the plate because the horizontal bending stresses in the plate was much higher than the fatigue strength of the tack weld detail. The crack grew into the tie plate from the tack weld toe. The tack weld between the flange angle and the web plate in the riveted girder shown in

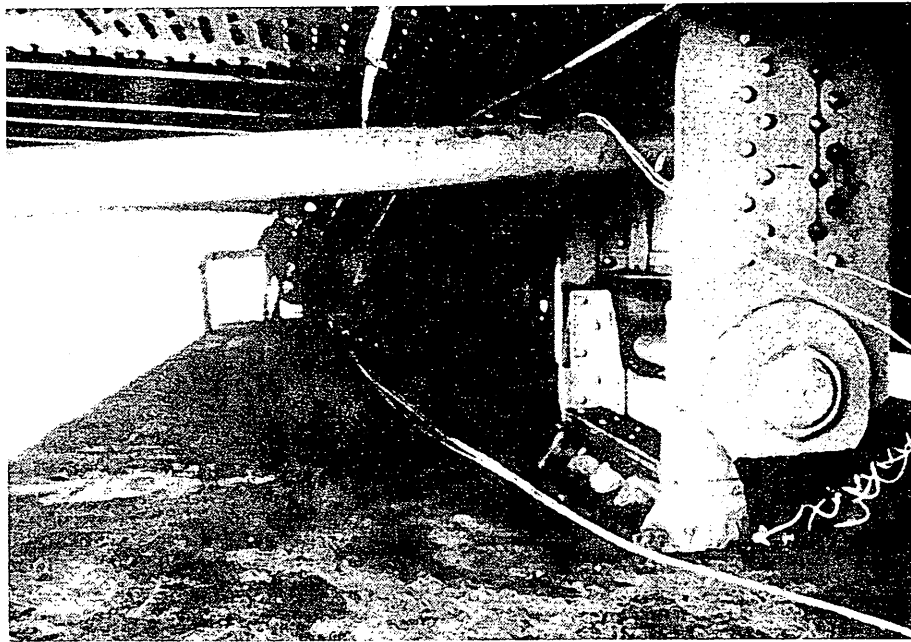
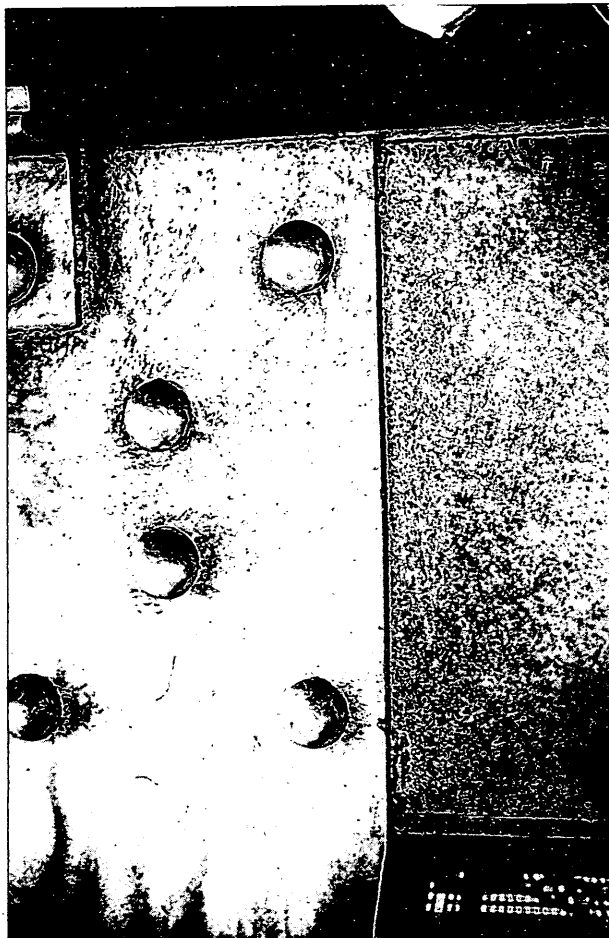

Fig. 5.14 Riveted Link and Anchoring Eyebars at
End of Suspension Bridge

Fig. 5.12 did not cause a fatigue crack; the out-of-plane deflection of the connection angle generated a crack in the angle. The tack weld between a hanger gusset plate and a truss chord member, shown in Fig. 5.15, caused a fatigue crack which initiated at the tack weld toe and propagated into the tension chord.

Often the crack has occurred in the tack weld throat, breaking it apart. This is the case at the truss panel point shown in Fig. 5.16. Careful removal of the cracked tack weld and examination with the aid of dye penetrant, revealed that the crack had not propagated into the chord member component.

While the tack welds may exist in various parts of a riveted structure, it is mostly at joints and connections where the existence of these tack welds and cyclic stresses cause fatigue cracking. All tack welds detected at and near the connection of bridge members should be recorded, the welds inspected, and the results reported. Similarly, all field welded attachments such as posting signs which were added to riveted bridge members should also be inspected and reported.



(a)

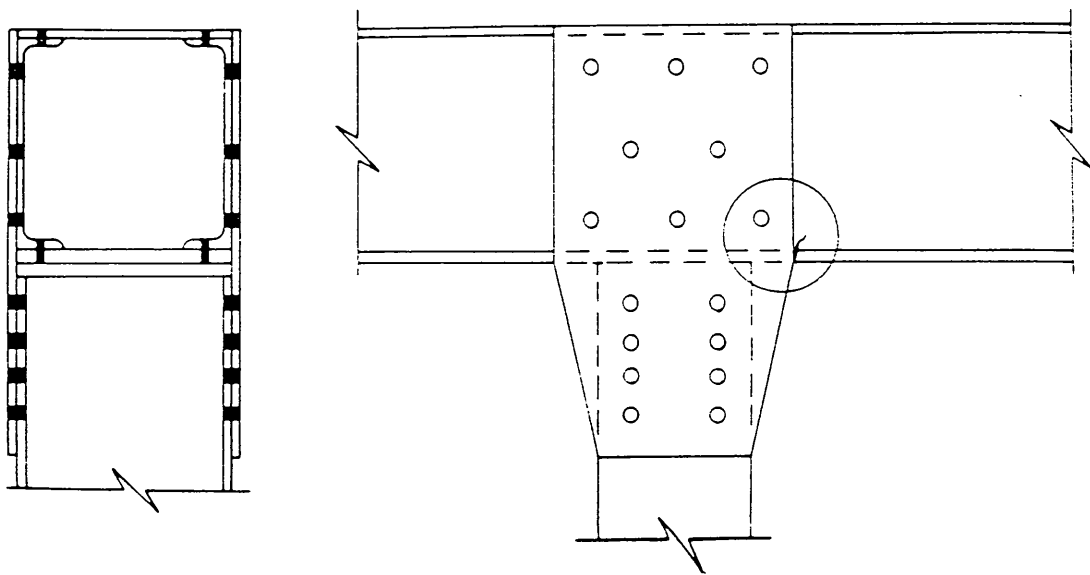

(b)

Fig. 5.15 Crack at Tack Weld between Hanger Gusset Plate and Truss Top Chord



Fig. 5.16 Lower Panel Point of Truss with Crack at Tack Welds

CHAPTER 6. INSPECTION OF REINFORCED CONCRETE AND PRESTRESSED CONCRETE HIGHWAY BRIDGES

6.1 General Discussion

In comparison with steel structures, concrete bridge structures are much less likely to be suffering from fatigue damage. In fact, reports of fatigue in concrete structures, whether reinforced or prestressed, have been extremely rare. Several factors can be cited as contributing to the apparent immunity of concrete structures to fatigue. The mass and stiffness of these structures are usually such that any vibration caused by the passing of a vehicle is quickly damped out. As a result, the structure experiences a smaller number of significant stress cycles per truck passage in comparison with steel bridge structures. Furthermore, cracking of concrete in the tension region does not affect the internal mechanism of stress transmission, since tensile resistance of concrete is universally ignored in design and analysis. Only the reinforcing bars in tension are susceptible to fatigue. Stress range limitations for standard deformed reinforcing bars have been experimentally established and incorporated in the design specifications⁽⁸⁾⁽²²⁾⁽²³⁾. Fatigue distress in concrete structures is also more difficult to detect than those in steel structures. Reinforcing bars are hidden from view by the concrete cover. Reinforcing bar details, such as bends, welds, and overlaps, which may attract fatigue damage, are also completely hidden. Inspectors can only examine the behavior of concrete surface cracks, and to infer their significance with regard to fatigue. They must depend upon design and construction information for the location of potential trouble spots. To further complicate the situation, there is no difference in the appearance between a fatigue crack in concrete and a crack caused by ordinary tension or shrinkage. However, fatigue cracks are expected to develop at existing cracks in the concrete.

6.2 Inspection of Reinforced Concrete Highway Bridges

An extensive survey in 1986, among bridge engineers, consulting engineers and researchers, has uncovered no report of observed fatigue failure of a reinforced concrete structural member in actual service. Several fatigue failure in experimental bridges and laboratory specimens have been reported, all under loading conditions more severe than normally expected in highway bridges. Superficially, therefore, it would appear that fatigue is not a critical concern for reinforced concrete highway bridges. Nevertheless, it is suggested that certain precautions be taken by the bridge inspectors.

1. Special attention should be paid to locations where fatigue distress in reinforcing bars is likely to occur, these locations include:
 - . Locations where live load tensile stresses are high: The midspan sections, the intermediate supports of continuous structures, the knees of rigid frame structures, etc.
 - . Locations of stress concentration in reinforcing bars: Bends, joints, and terminal points.
 - . Locations of section changes: Hunches, and beam diaphragm joints.
2. Since reinforcing bar details are not visible externally, much of the above information must be gathered from design and construction files.
3. Transverse cracking is normally expected at the maximum stress sections and where member sections change. Such cracking is not detrimental by itself. However, extension of such cracks with time may reflect internal distress.
4. It is not possible to visually distinguish a fatigue-induced concrete crack from one caused by simple tensile stress. Therefore, if a crack is observed in an area having one or more of the characteristics listed in item 1 above, it is prudent to regard it as fatigue-induced, particularly if elongation or widening of the crack has been noted over a period of time.
5. Corrosion of reinforcing bars, though not necessarily fatigue-inducing, may aggravate an already existing fatigue condition. Cracking directly along a reinforcing bar, rust stains along a crack, and spalling of concrete are signs of internal corrosion damage.
6. Members with low dead load stresses are more susceptible to fatigue problems.

6.3 Inspection of Prestressed Concrete Highway Bridges

All of the discussions and suggestions in the preceding sections, 6.1 and 6.2, apply to prestressed concrete bridge structures. Generally speaking, the risk of fatigue failure is lower for prestressed concrete bridge members than for ordinary reinforced concrete members. This is because of the precompression in concrete, and the relatively low stress range in the prestressing (as well as unprestressed) steel elements. Early researchers on pretensioned structural members had generally concluded that fatigue was not a serious risk for these members⁽²⁴⁾⁽²⁵⁾. More recently, however, fatigue failures of prestressing tendons have been observed in several laboratory studies⁽⁴⁾⁽⁵⁾⁽²⁶⁾. There is a consensus among researchers that fatigue risks are significant for prestressed concrete members in which tensile stresses occur in precompressed concrete under live load, as permitted by the AASHTO Design Specifications after 1965⁽²⁷⁾. In addition to the potential of concrete tensile stresses, several other conditions have also been recognized as having a detrimental impact on the fatigue behavior of prestressed concrete bridge structures. These include: (1) post-tensioned prestressing elements, particularly if unbonded, (2) deflected prestressing elements, particularly in pretensioned members in which the changes of direction of the prestressing tendons are always concentrated at the deflection (hold-down) points, and (3) I-shaped beam cross-sections, which are torsionally less stiff than the box cross-sections. Other conditions adversely affecting fatigue behavior are blanketed pretensioning strands, spliced prestressing elements, and pre-post-tensioned structural elements. Beams with larger than expected loss of prestress may also be at risk for fatigue damage.

It is clear that the inspection for fatigue damage of prestressed concrete highway bridges should be focussed on the situations enumerated in the previous paragraph. However, except for the shape of the precast beams, the situations described are not

distinguished by visual examination. Records of design and construction must be relied upon.

Cracks often occur in prestressed concrete beams at unexpected locations due to design or construction inadequacies. These situations include poor detailing of reinforcing steel, floating of voids in box beams, uneven concrete cover on reinforcing steel, excessive lifting and handling stresses, and excessive skew angle. These cracks are not induced by live load stresses and generally do not present fatigue problems. However, the potential for corrosion, which may accentuate the fatigue condition, should be recognized. Impact damages and repairs of prestressed concrete beams may also induce unfavorable stress conditions and shorten the fatigue life of the members.

CHAPTER 7. ESTIMATION OF FATIGUE LIFE

7.1 Introduction

This chapter is written to provide fundamental guidelines to bridge engineers for the estimation of remaining fatigue life of existing bridge structures. Here, fatigue life is defined as the length of time before an initially microscopic flaw in a critical structural detail develops into a crack of certain length (typically about an inch or the thickness of the material) and becomes detectable by normal non-destructive inspection techniques (most commonly visual observation). This condition is commonly referred to as the “initial detection or observation of cracking”. Although it clearly indicates distress, catastrophic structural failure is not necessarily imminent. Further application of loading would cause the crack to extend. Only after significant growth of the crack is the situation likely to become critical and the crack unstable so that failure occurs, in the form of brittle fracture. The phenomena of crack growth and brittle fracture are not within the scope of this manual and are described only briefly in Chapter 8. The central focus of this chapter is on the initial stage when the crack has not been detected.

The principal parameters controlling the fatigue life include the nature of the structural detail, the stress range experienced by the detail, and the volume and variation of live load traffic on the bridge. Dependent on the nature and fabrication of the detail, its fatigue characteristics are represented by the S-N curve of the appropriate category as shown in Figure 2.1. While S-N curves are referenced to constant amplitude stress cycles, the stress cycles experienced by actual bridge structural details vary over a considerable range on account of the variability of truck weights, truck configuration and location of vehicles traversing the bridge. A method is needed to assess the fatigue damage under variable stress range spectrum. One such method uses an equivalent

constant amplitude stress range, which causes the same damage and fatigue life as the actual variable stress range spectrum. The traffic volume information is needed to establish the number of stress cycles and to convert the fatigue life into a length of time. In essence, the fatigue evaluation of a bridge structure involves the establishment of the fatigue category of the critical detail, the estimation of an equivalent stress range, the estimation of the number of stress cycles experienced by the structural detail, and finally the estimation of the remaining fatigue life in terms of time units. The fatigue categories were described in Chapter 2. The remainder of this chapter addresses the other components listed above.

7.2 Estimation of Equivalent Stress Range

Various methods have been used to arrive at a reasonable value for the equivalent constant amplitude stress range. These methods are different in their degree of sophistication, their site-specificity, as well as their effort and fund requirements. The selection of the most suitable method is dependent upon the degree of accuracy needed. Three of these methods are described here.

7.2.1 Direct Measurement of Stress Range

The most site-specific and very likely the most costly method requires the field measurement of stresses under actual traffic condition. Strain gages are generally used at the location or detail of interest on the structure, and strains are monitored and recorded over a period of time sufficiently long to provide a realistic representation of the traffic pattern (about two days). Figure 7.1 shows a typical strain-time record caused by the crossing of one single truck over a simple girder bridge. The shape of the curve generally resembles that of an influence line, but with superimposed strain fluctuations reflecting the vibrations of the structure due to the moving loads.

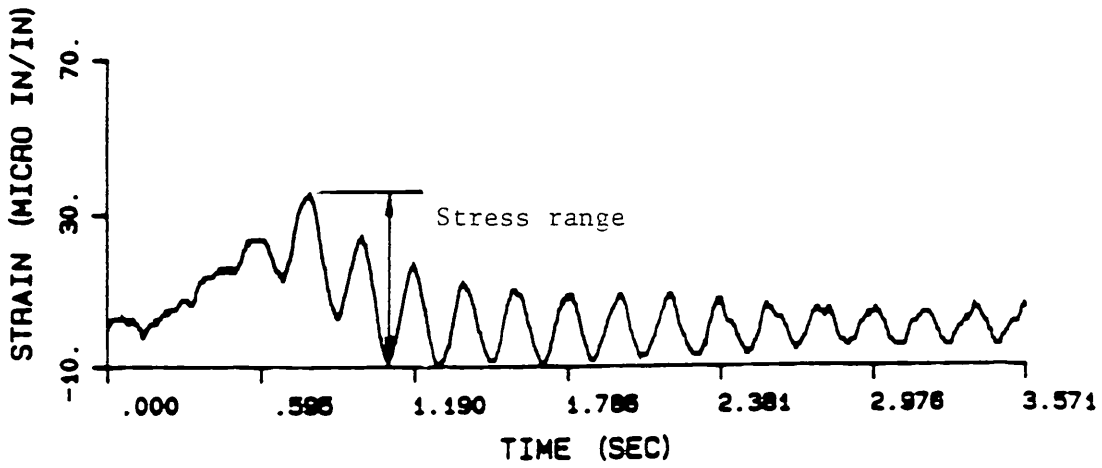

Fig. 7.1 Typical Strain-time Record from a simply supported bridge girder caused by one single truck

The strain-time record over a sufficiently long time is first reduced to a stress range histogram, showing the frequency of occurrence of stress cycles with various range magnitudes. Several methods can be used to count the number of cycles. Detailed description can be found in various books and reports⁽²⁸⁾⁽²⁹⁾. The simplest and also the most commonly used in the past is the “peak to peak” counting method. By this method, each truck crossing is counted as causing one stress cycle, and the stress range magnitude is taken as the algebraic difference between the maximum and minimum stresses on the record, with tensile stress treated as positive and compressive stress as negative. The conversion from strain to stress is usually done by simply multiplying by the modulus of elasticity of the material. With the advent of micro processors, most field measurement data are now processed using the rain flow counting procedure to produce stress range histograms.

Figure 7.2 shows an example of measured stress-range histogram in which the ordinate shows the fraction of stress cycles having range magnitudes within each finite interval. The equivalent constant amplitude stress range is commonly determined by invoking Miner’s rule, which stipulates linear cumulation of fatigue damage, or

$$\sum \frac{n_i}{N_i} = 1 \quad (7.1)$$

where n_i = number of stress cycles with range magnitude S_{ri} , and N_i = fatigue life corresponding to constant stress range S_{ri} as determined from the appropriate S-N curve. Since the typical S-N curve, for steel and concrete alike, has a gradient of $-1/3$, the equivalent constant amplitude stress range based on Miner’s rule is the “root-mean-cube” value of the variable stress ranges.⁽³⁰⁾

$$S_{re} = \left(\sum \gamma_i S_{ri}^3 \right)^{1/3} \quad (7.2)$$

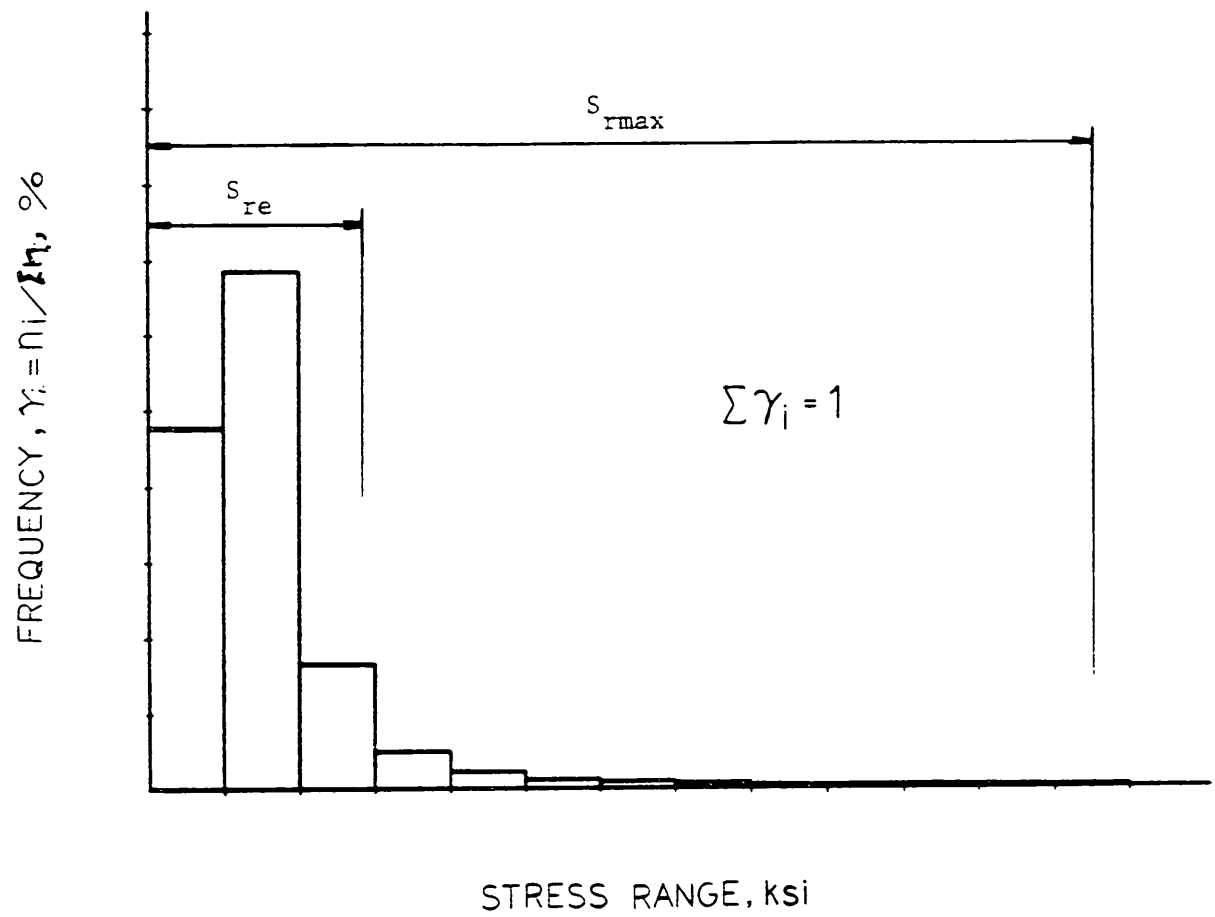

Fig. 7.2 Typical Stress-Range Histogram

where, γ_i is fraction of occurrence of stress range S_{ri} , or $n_i/\sum n_i$. It is to be noted that because of the typically skewed distribution of the stress range histogram, the equivalent stress range S_{re} is significantly lower than the maximum stress range $S_{r,max}$. A ratio as low as 30% is not uncommon.

An alternate method of calculation uses the root-mean-square value for the equivalent stress range.

$$S_{rs} = \sqrt{\sum \gamma_i S_{ri}^2} \quad (7.3)$$

An examination of the Equations 7.2 and 7.3 reveals that the root-mean-square value S_{rs} will always be lower than the root-mean-cube value S_{re} . Consequently, using the root-mean-square method will always lead to a less conservative estimate of the fatigue life. Miner's rule method is the preferred means of estimating cumulative damage. All examples in this report are based on that method.

It should be pointed out that the basic concept of equivalent stress range implies that the total number of stress cycles is not being altered.

7.2.2 Equivalent Stress Range by AASHTO Design Stress

A simple but generally conservative alternative to the field measurement method uses the AASHTO design live load (and impact) stress as the basis for fatigue evaluation. The greatest advantage of this method lies in its reliance on the AASHTO provisions, which are thoroughly familiar to bridge engineers. In fact, in most cases, these stress values can, be directly extracted from the design data for the bridge under consideration.

It should be pointed out that the AASHTO design provisions are primarily aimed at assuring the load carrying capacity of the bridge structure to be constructed. These design provisions include various safety factors which are necessary to account for the variability of the traffic load, including loads which exceed the ASSHTO

standard vehicle, but may not be appropriate for fatigue considerations. In general, the actual stress ranges in a real structure are significantly lower than the live load and impact stresses predicted from the design model. In addition, this approach does not distinguish between $S_{r,max}$ and S_{re} . Consequently, this method tends to lead to very conservative estimates of fatigue life.

7.2.3 Single Truck Methods

Extensive experience with field observations has shown that most of the stress cycles in a bridge structure are caused by single vehicle passages. The condition of fully loaded vehicles in multiple lanes occurs only very infrequently. Based on this observation, various attempts have been made to develop simple methods for the estimation of the equivalent constant amplitude stress range. Fisher, et al⁽³¹⁾⁽³²⁾ have proposed the use of a single HS-20 truck, and to calculate the equivalent stress range following the provisions of AASHTO bridge design specifications⁽⁸⁾. Alternately, Moses, et al⁽³³⁾ have proposed the use of a “fatigue truck”, which is similar to an HS-15 truck, with associated provisions regarding impact factor and lateral distribution factors. Both of these methods are aimed at a quick determination of an approximate value for the equivalent stress range S_{re} . Ease of computation considerations and a moderate margin of conservatism are their major attributes. Both methods take into account the infrequent occurrence of the extreme stress ranges by relating the proposed single vehicle load to the variable load spectrum. Hence, heavier live loads, such as the Pennsylvania ML80 trucks, are included in the variable loading envelope. In the future, the frequency of these heavier loads may increase. The evaluation procedure will then need to be adjusted.

7.3 Estimation of Fatigue Life

7.3.1 Estimation of Total Fatigue Life

To evaluate the fatigue safety of an existing bridge structure, the maximum stress range, $S_{r,max}$, should first be compared with the fatigue limit for the detail in question. The maximum stress range must be evaluated considering overload. Fatigue limit is defined as the constant amplitude stress range, below which the detail will be able to endure unlimited number of cycles without developing fatigue cracks. The fatigue limits for the various detail categories are specified in Table 10.3.1A of the AASHTO Bridge Specifications⁽⁸⁾, as the allowable stress range, F_{sr} , for "over 2,000,000 cycles" of applications. The values are represented in Figure 2.1 as the horizontal thresholds of the S-N diagrams. It is apparent from Fig. 2.1 that the fatigue limit for the more severe details corresponds to a higher number of stress cycles. For category A, the fatigue limit is the same as the allowable stress range "for 2,000,000 cycles" of application. In contrast, for a category E' detail, the fatigue limit is much lower, reflecting almost 18,000,000 cycles of application. It should be noted that the fatigue limit of a detail corresponds to the redundant load path value. The lower values for "non-redundant load path" members are intended to provide for increased conservatism in design in view of the uncertainty of actual loading.

If all random variable stress ranges are below the fatigue limit, $S_{r,max} \leq F_{sr}$, cumulative fatigue damage will not develop, and the fatigue life is infinite.

If $S_{r,max} > F_{sr}$, fatigue cracking is expected after a large number of stress cycles. The total fatigue life of the detail may be tens of million stress cycles, but not unlimited. It is obtained based on the equivalent stress range S_{re} , which is most likely less than the fatigue limit. To estimate the fatigue life in this case, the fatigue limit of the S-N diagram is not applicable. The descending segment of the S-N design curve is extended and used to evaluate the total fatigue life. This is illustrated in Figure 7.3,

wherein N_t represents the total fatigue life, in number of cycles.

7.3.2 Estimation of Remaining Fatigue Life

An accurate estimation of the number of stress cycles experienced to-date by a bridge structure requires knowledge of the traffic volume and history on the bridge. While the current traffic volume can be accurately determined by an on-site survey, historical information may not exist for most bridges, and may need to be estimated. Projections for the future trend is obviously subjected to a high degree of uncertainties. Probable sources for historical traffic information include the traffic engineer's office and the local community. Figure 7.4 shows an example of ADTT (average daily truck traffic) volume variation with time based on available traffic data. The area under the ADTT curve represents the total number of stress cycles experienced by the bridge within a specified period of time. Dependent on the characteristics of the bridge as well as the vehicle, each truck crossing event may cause one or more stress cycles at a given detail. The number of cycles to date, N_p , is calculated from the ADTT curve, with an estimate of number of stress cycles per vehicle.

The degree of cumulated fatigue damage to date is estimated by comparing the cycles to date N_p with the total fatigue life N_t . The difference between these two values is the remaining fatigue life, N_r , as shown in Figure 7.3.

$$N_r = N_t - N_p \quad (7.4)$$

The conversion of N_r into a length of time is dependent upon the projected ADTT curve, shown in dashed line in Figure 7.4.

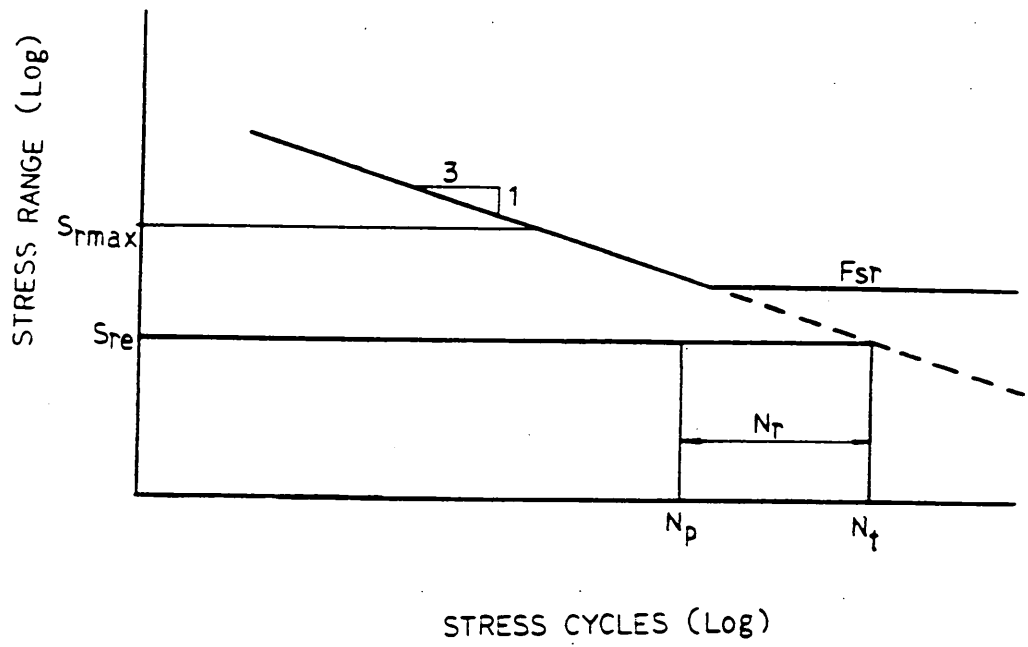

Fig. 7.3 Estimation of total Fatigue Life and Remaining Fatigue Life

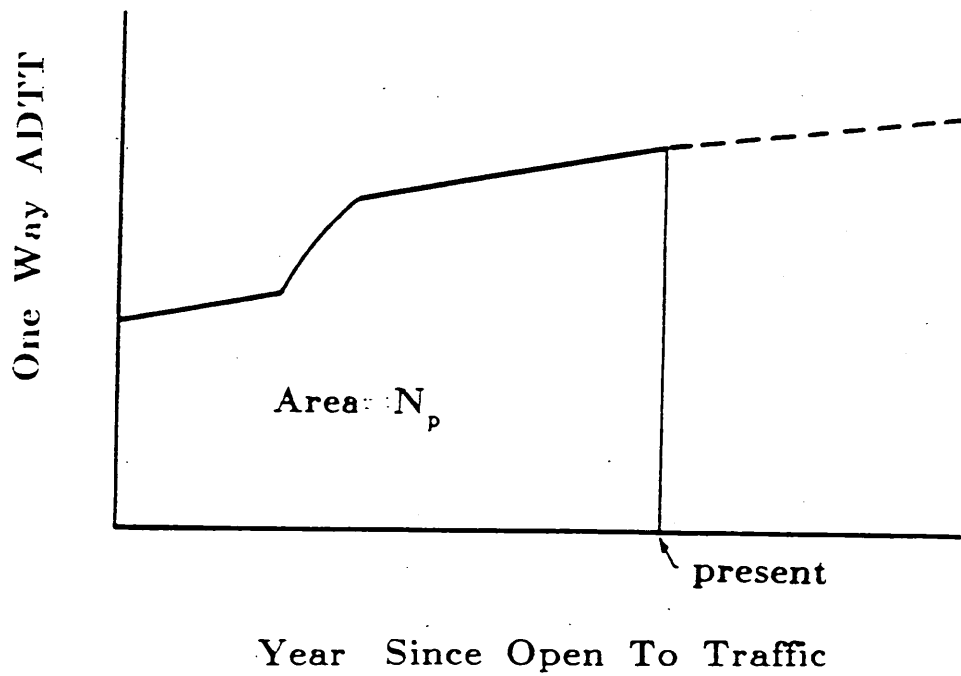

Fig. 7.4 ADTT Variation with Time

7.4 Procedure for the Estimation of Fatigue Life

Summarizing the preceding discussion, a practical procedure for the estimation of fatigue life is proposed as follows:

1. Examine the structural detail in question and determine its fatigue category.
2. Estimate the maximum stress range, $S_{r,max}$, and the equivalent constant amplitude stress range, S_{re} , using a method of the engineer's choice. The value of $S_{r,max}$ must reflect the extreme stress values caused by legal and illegal overloads. These extreme heavy loads are the primary reasons that the fatigue limit may be exceeded at bridge details.
3. If the maximum stress range, $S_{r,max}$, does not exceed the fatigue limit, F_{sr} , of the structural detail in question, fatigue cracking is unlikely to occur. The fatigue life is taken as infinite. Additional assessment is unnecessary at this time.
4. If $S_{r,max}$ exceeds F_{sr} , the fatigue life is not infinite, and the risk of fatigue cracking must be assessed. The total fatigue life, N_t , is determined, using the appropriate S-N relationship and the equivalent constant amplitude stress range, S_{re} .
5. Use the ADTT information to determine the stress cycle to date, N_p , and the remaining fatigue life, N_r . Use projected ADTT information to convert N_r to number of years. If the remaining fatigue life is judged to be inadequate, retrofitting or strengthening measures are required. (A more sophisticated estimation of S_{re} may yield a lower value and a longer remaining life, rendering strengthening unnecessary. Engineering judgement should be exercised).

7.5 Illustration Examples

7.5.1 Example 1: Estimation of Fatigue Life by the Field

Measurement Method

The method described in Section 7.2.1 is used to evaluate a bridge structure, with reference to a category E' detail. The stress range histogram from field measurements, based on a representative sample of 2064 truck crossings, is shown in Figure 7.5. The historical ADTT record since the opening of the bridge to traffic is as shown in Figure 7.6.

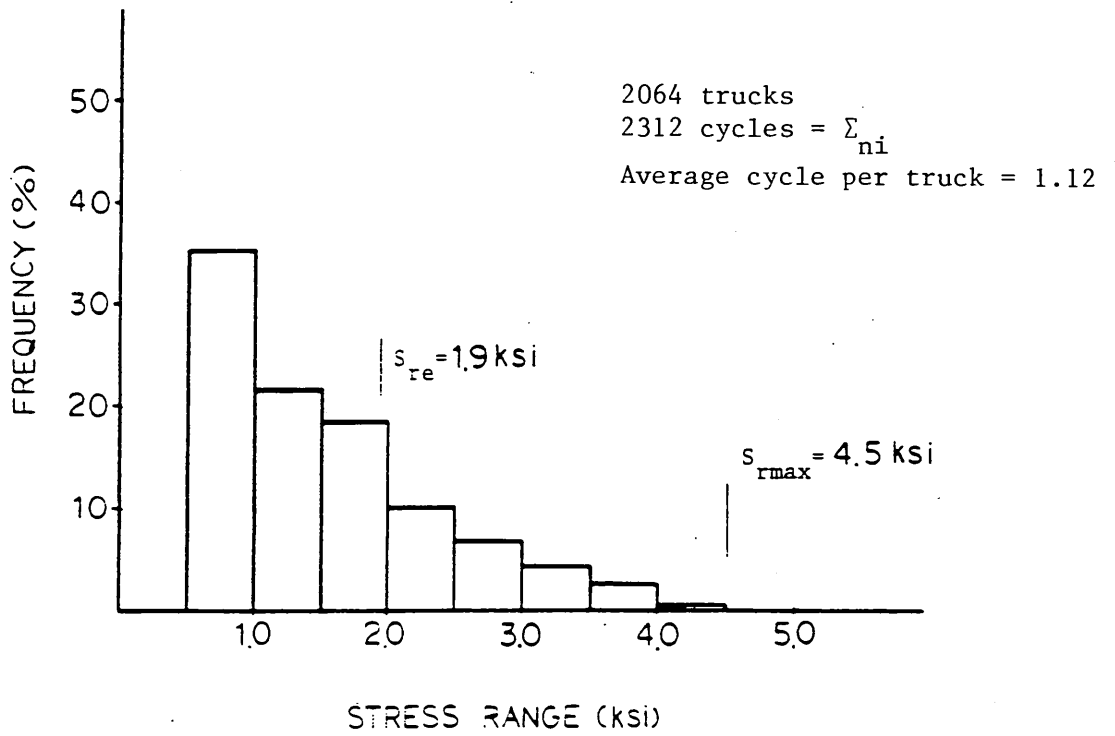

Fig. 7.5 Field Measured Stress Range Histogram for Example 1

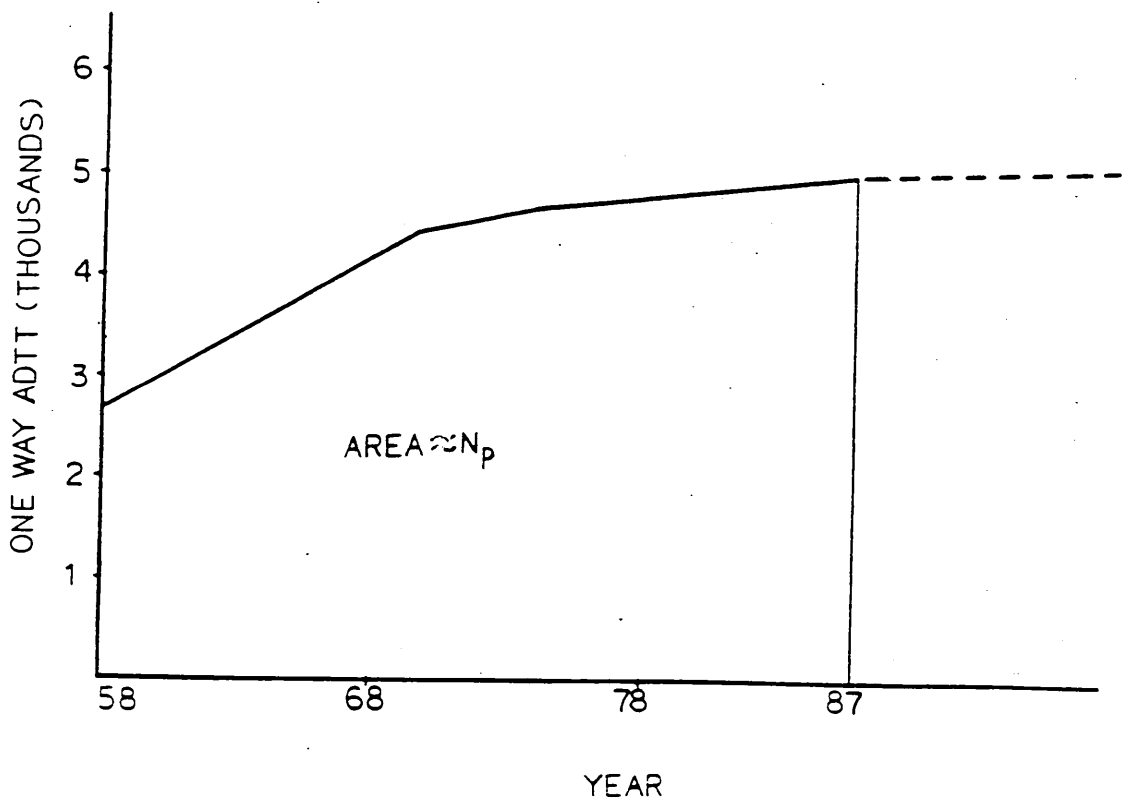

Fig. 7.6 ADTT Record for Example 1

1. The fatigue limit for a category E' detail, for redundant load path, is $F_{SR} = 2.6$ ksi.
2. From Figure 7-5, $S_{r,max} = 4.5$ ksi, $S_{re} = 1.9$ ksi (based on eq. 7.2)
3. $S_{r,max} > F_{SR}$, therefore, fatigue life is not infinite
4. From Figure 7.7, $N_t = 49 \times 10^6$ cycles
5. From Figure 7.6, using the area under the ADTT curve and the average 1.12 stress cycles per truck, it is estimated that $N_p = 39.2 \times 10^6$ cycles. Therefore, remaining fatigue life $N_r = N_t - N_p = 9.8 \times 10^6$ cycles.

Assuming the ADTT to remain constant at 5,000 in the future, and each truck crossing to produce the same average number of stress cycle in the structural detail, the estimated remaining fatigue life in years is computed as:

$$\frac{9.8 \times 10^6}{5,000 \times 1.12 \times 365} = 4.8 \text{ years}$$

Since the evaluation is based on field measured stress ranges, the estimate remaining life is fairly accurate. If this estimated remaining life is judged to be inadequate, retrofitting and strengthening are needed.

7.5.2 Example 2: Estimation of the Equivalent Constant Amplitude Stress

Range by a Single HS-20 Truck

The method described in Section 7.2.3 will be applied to a steel plate-girder bridge with a cross section as shown in Figure 7.8. The five W36X170 girders are spaced at 8'-0" c.c. and are simply supported over a 90' span. The evaluation is focussed at the ends of the bottom cover plates, 14'-6" from the supports. The composite concrete deck slab has a structural thickness of 8". The end of cover plate detail is of fatigue category E.

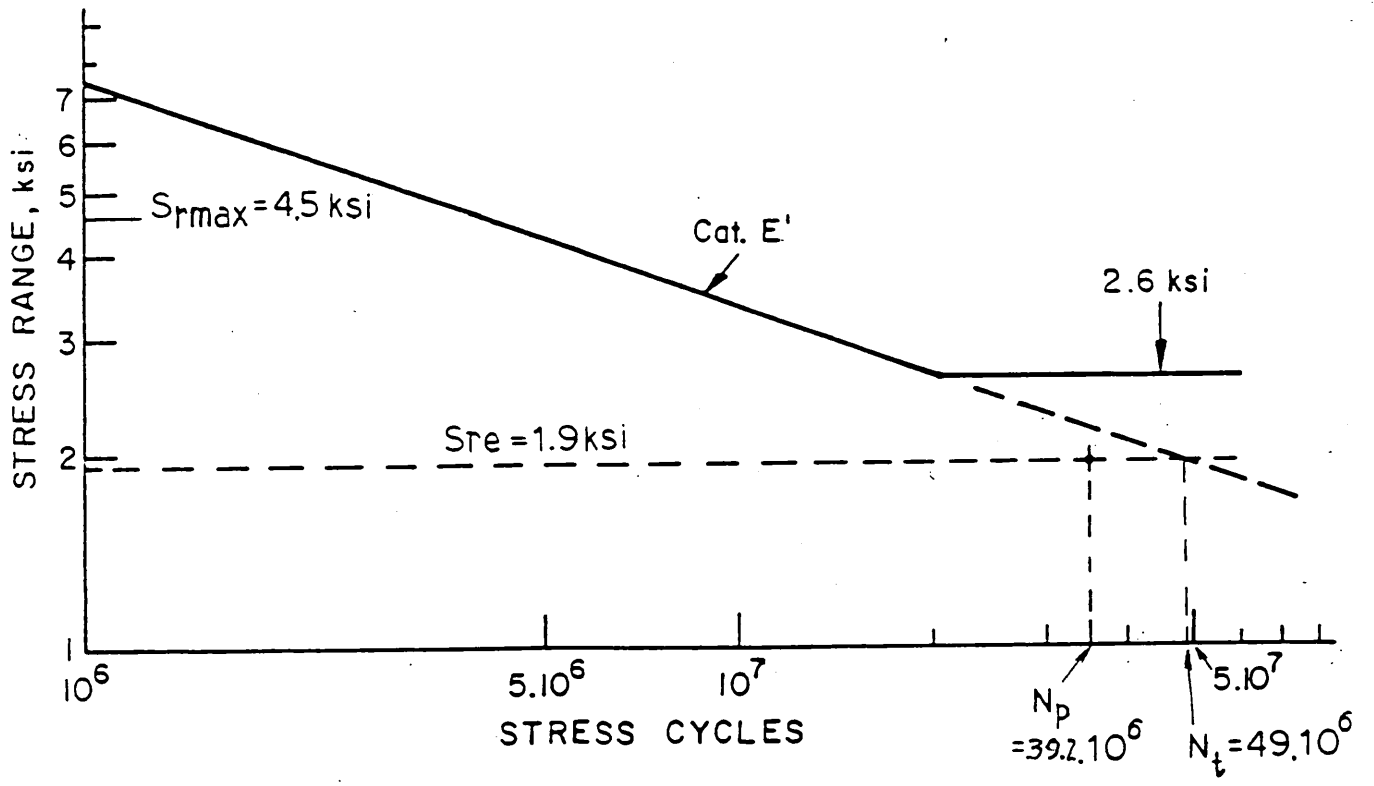

Fig. 7.7 Estimation of Remaining Fatigue Life for Example 1

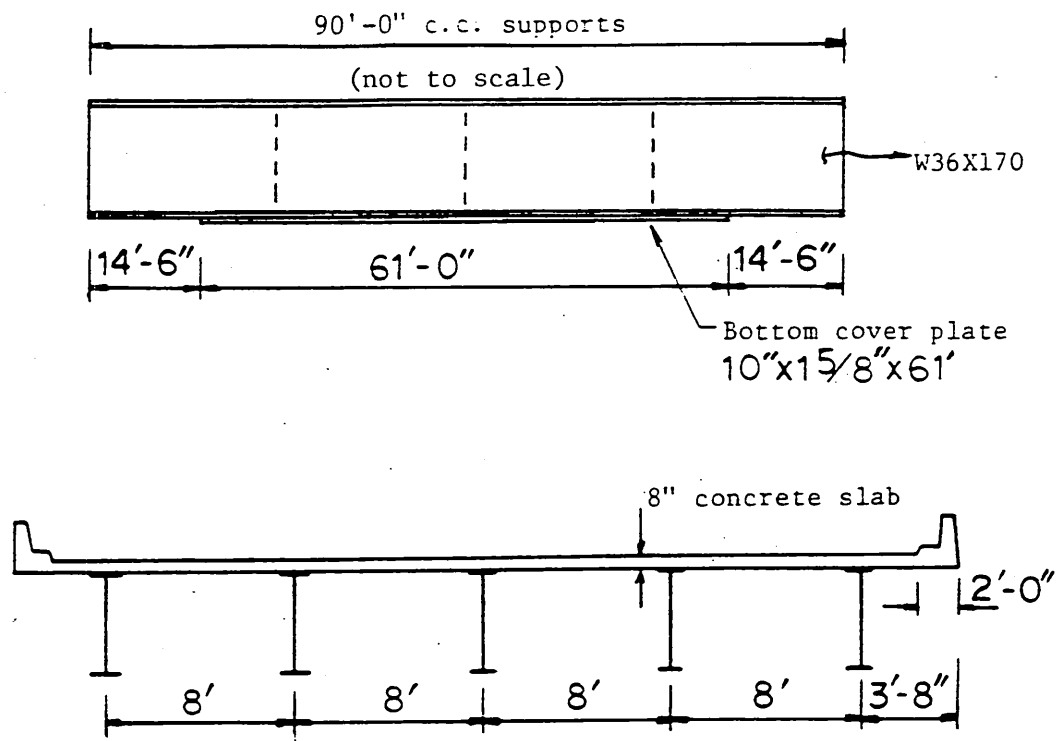

Fig. 7.8 Bridge Geometry for Example 2

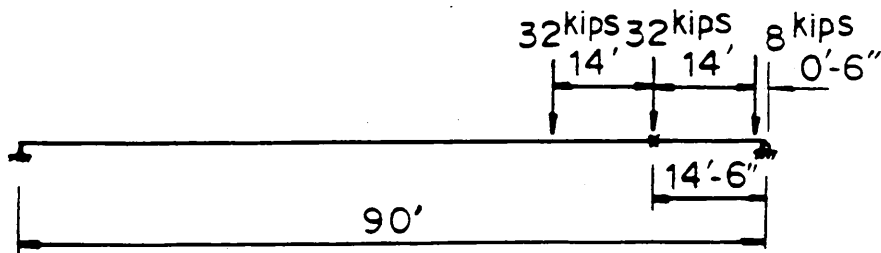

Fig. 7.9 Longitudinal Location of Truck for Producing Maximum Stress Range for Example 2

The HS-20 truck is placed on the bridge as shown in Figure 7.9 to produce maximum moment at the cross section at the end of the cover plate, 14'-6" from the end of girder. The live load moment produced by one single HS-20 truck is

$$M = \frac{14.5}{90} \times (8 \times 89.5 + 32 \times 75.5 + 32 \times 61.5) - 8 \times 14 = 709 \text{ k-ft}$$

To produce maximum effect in the exterior (fascia) girder, the truck is laterally placed as closely as possible to the curb, as shown in Figure 7.10. The live load moment in the exterior girder is

$$M = 709 \times \frac{1}{2} \times \left(\frac{92}{96} + \frac{20}{96} \right) = 413.3 \text{ k-ft}$$

In accordance with the AASHTO Specification⁽⁸⁾, the impact coefficient is:

$$I = \frac{50}{L + 125} = \frac{50}{90 + 125} = 0.233 < 0.3$$

Therefore, the live load plus impact bending moment in the exterior girder is:

$$M_{L+I} = 413.3 \times 1.233 = 510 \text{ k-ft}$$

The composite cross section of the exterior girder is assumed to be as shown in Fig. 7.11, ignoring the effect of the curb and parapet.

Using a modular ratio of 8, the neutral axis is determined to be 32.39 in. from the bottom of flange plate, and the section modulus for the bottom fiber is:

$$S = 827 \text{ in}^3$$

The live load plus impact stress at the detail is:

$$\frac{M}{S} = \frac{510 \times 12}{827} = 7.79 \text{ ksi}$$

For a simple span structure, the stress range is the same as the maximum stress. Therefore, the estimated equivalent constant amplitude stress range is:

$$S_{re} = 7.79 \text{ ksi}$$

To assess the stress condition of this detail against fatigue, the calculated effective stress range, S_{re} is compared with the fatigue limit stress range F_{sr} . From Appendix A, the fatigue limit F_{sr} for a category E detail is 4.5 ksi. Since the estimated effective stress range exceeds the fatigue limit by a large margin, early fatigue crack development and growth are indicated. In fact, the estimated total fatigue life of this detail is slightly less than 2 million cycles, which is probably not adequate for the bridge in question. A more refined estimate of S_{re} by direct measurement by finite element analysis may result in a better and longer estimated fatigue life.

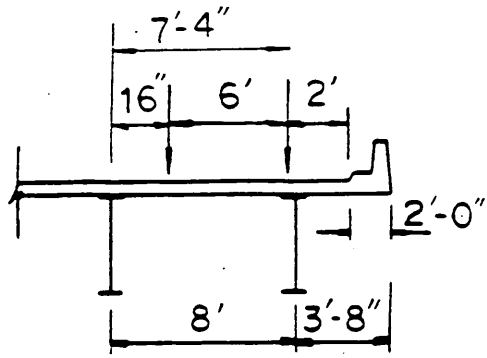

Fig. 7.10 Transverse Location of Truck for Computing Stress Range in Exterior Girders for Example 2

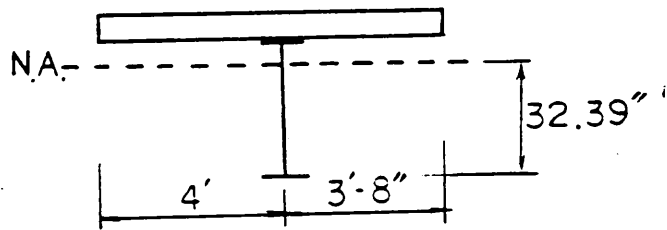

Fig. 7.11 Composite Cross-section of the Exterior Girder for Example 2

CHAPTER 8: RATING ON THE BASIS OF FATIGUE DAMAGE

8.1 Introduction

Rating is commonly understood to refer to the estimation of the load carrying capacity of an existing structure, based on certain performance limitation. The AASHTO Maintenance Manual⁽¹⁰⁾ lists the commonly considered limiting factors as strength (including flexure, shear, axial load and combinations thereof), serviceability (including deflection, vibration, and cracking of concrete), and fatigue. In most cases, the occurrence of the limiting live load, with appropriate safety factors, is expected to induce certain undesirable behavior in the structure, such as material failure or excessive deflection. Consequently, such occurrences are to be prevented. The fatigue limitation is very different. A small number of occurrences of live load stress cycles at or above the allowable fatigue stress range will not produce any detectable ill-effect in the structure. Even stress ranges significantly higher than the "allowable stress range" are tolerable, as long as the occurrences are infrequent and the total cycles moderate so that the cumulative damage is low. Therefore, fatigue limitation is more rationally represented in terms of remaining life, as discussed in detail in Chapter 7 and not on load magnitudes.

On occasions when a bridge with fatigue cracks has to be kept in service for a short period of time before retrofitting and strengthening, temporary limitation on the magnitude of live load may be necessary. The primary concern here would be the condition of the crack and its influence on the bridge member and the structure. The attention must be focussed on the danger that the crack may extend rapidly, causing severe deflection or sudden collapse of the bridge. Evaluation of such risk is based to the theories of crack propagation and brittle fracture⁽³²⁾. Sections 8.2 and 8.3 provide

very brief descriptions of these theories.

8.2 Load-Rating Based on Brittle Fracture

It is important to limit the total stress at the tip of a crack in a bridge member, so that brittle fracture does not take place. This is achieved by limiting the stress intensity factor of the crack to a critical value corresponding to crack instability.

$$K_{\max} = CS_{\max} \sqrt{\pi a} \leq K_{IC} \quad (8.1)$$

where K_{\max} = Maximum stress intensity factor of the crack, ksi $\sqrt{\text{in}}$
 C = Constant dependent upon the shape of the crack, other geometrical factors and the conditions of the member
 S_{\max} = Maximum nominal total tensile stress at the tip of the crack, caused by dead and live loads, including residual stresses, ksi.
 π = 3.1416
 a = Crack length, in.
 K_{IC} = Critical stress intensity factor, a material characteristic, ksi $\sqrt{\text{in}}$

The limitation on the nominal total stress is,

$$S_{\max} \leq \frac{K_{IC}}{C\sqrt{\pi a}} \quad (8.2)$$

To guard against brittle fracture, the live load on the structure must be so restricted that the maximum total nominal tensile stress at the crack tip, including the effects of dead load, live load, impact, and residual stresses, does not exceed the value of S_{\max} from eq. 8.2, with an appropriate factor of safety. The computation of the dead and live load stress should be made considering the actual total structural system instead of the simplified design procedure. The factor of safety must be selected considering the uncertainties in the material and structural characteristics, as well as the enforcement of the load limit.

8.3 Evaluation Based on Crack Propagation

After the detection of fatigue cracking in a bridge member but before retrofitting, the crack may continue to grow, or propagate, even if a load limit is posted and the live

loads are not as heavy as before. It is important that the crack does not grow to such size as to trigger brittle fracture.

The basic relationship governing the growth or propagation of a crack in a steel bridge member is as follows:

$$\frac{da}{dN} = 3.6 \times 10^{-10} (\Delta K)^3 \quad (8.3)$$

where a = Crack length, in.

N = Number of stress cycles

ΔK = The range of stress intensity factor, ksi $\sqrt{\text{in}}$
 $= C S_r \sqrt{\pi a}$

C = Constant dependent upon the shape of crack, other geometrical factors and conditions of the member

S_r = Stress range due to posted live load, ksi

π = 3.1416

Integration of Eq. (8.3) yields the following equation for the estimation of the number of stress cycles which would cause the growth of a detected crack from a_i to a_f .

$$\Delta N = \int_{a_i}^{a_f} \frac{da}{3.6 \times 10^{-10} (\Delta K)^3} \quad (8.4)$$

where a_i = Initial crack length, in.

a_f = Final crack length which the member can endure, in.

Eq. (8.4) provides an estimate of stress cycles which can be tolerated before retrofitting. The actual truck traffic volume until retrofitting must not generate more stress cycles than ΔN . Otherwise, the posted load must be lowered.

It should be pointed out that permitting a bridge structure with fatigue cracks to remain open to traffic (even with posted load limits) is an important and serious decision, which should be made judiciously. Cracks in primary structural members are

more critical than those in secondary members or those related to out-of-plane displacements. The procedures described in this chapter are intended for general information and reference. Detailed evaluation of bridge members with fatigue cracks depends upon the physical condition of the member and its interaction with other components of the entire structural system. Engineering experience and judgment are essential.

CHAPTER 9. DISCUSSION AND RECOMMENDATIONS

9.1 Recommended Procedure for Inspecting for Fatigue Damages

1. Before field inspection, examine available structure drawings of the bridge to identify low fatigue strength details, such as welded cover plates on tension flanges of beams and diaphragm connection plates not attached to flanges.
2. During field inspection of the bridge structure, pay special attention to details which are susceptible to fatigue cracking. Visual inspection of locations suspected of cracking using a magnifying glass can be followed with other methods such as dye penetrant, etc. Locations where dirt and debris accumulate are susceptible to saturation from water and salt, and corrosion notching. These locations should be given special attention.
3. Document the location, dimension, and orientation of cracks, as well as location of suspected cracks. Record locations of excessive corrosion. Sketches and color photographs should be made.
4. Report the results of inspection. Discuss with bridge engineers on the need of further in-depth inspection and on collection of design information and traffic conditions for evaluation.

9.2 Recommended Procedure for Evaluation

Dependent on whether fatigue cracks have been detected in a bridge structure, different evaluation procedures are recommended.

For structures without observed cracks, the evaluation is to be based on the remaining fatigue life. The procedure in Section 7.4 should be used. In summary, the procedure includes the following steps.

1. Identify the fatigue category and the controlling S-N curve of the structural detail in question.
2. Estimate the maximum stress range, $S_{R, \max}$, and the equivalent constant amplitude stress range, S_{Re} , using a method of the engineer's choice.

Examples are:

- 2a. AASHTO design stress method
 - 2b. Single truck method (for S_{Re} only)
 - 2c. Stress range histogram method
3. If $S_{R, \max}$ is less than the fatigue limit stress, F_{SR} , of the detail in question, fatigue cracking is unlikely to develop.
 4. If $S_{R, \max}$ exceeds F_{SR} , evaluate the total fatigue life, N_t , using the appropriate S-N curve and the equivalent stress range S_{Re} .
 5. Use ADTT information to determine the number of stress cycles to-date, N_p . Calculate the remaining fatigue life, N_r , as difference between N_t and N_p . Convert N_r to number of years by the projected ADTT volume.
If the remaining fatigue life is judged to be inadequate, retrofitting or strengthening will be required.

Generally speaking, the use of AASHTO design live load stresses as $S_{R\max}$ and S_{Re} tends to yield the most conservative estimate of fatigue life. However, because these stresses are normally available, method 2a can be used initially. The other methods may be used if a more refined estimate is desired.

For structures with detected cracks, the focus of attention is on crack propagation and prevention of severe redeflection or sudden collapse of structure due to brittle fracture. The procedure described in Chapter 8 should be used in consultation with experienced engineers.

9.3 Discussions

This manual is intended for use by bridge inspectors. It provides information on what and where to look for fatigue cracks. The examples included in the manual represent the more commonly encountered conditions, and should not be taken to be exhaustive. Additional information, presented in a slightly different format is listed in Appendices B and C.

The recommended procedures for evaluating bridge structures with regard to fatigue damage are based on the most up-to-date research information.

At the present time, engineering knowledge is not sufficient for the development of an accurate and unified procedure. As more research results become available, improvement of the procedures should be made.

ACKNOWLEDGEMENTS

This manual was compiled at the Fritz Engineering Laboratory, Department of Civil Engineering, of Lehigh University. Financial support was provided by the Pennsylvania Department of Transportation and the US Department of Transportation Federal Highway Administration. The interest and support of these agencies are gratefully acknowledged.

Most of the examples of fatigue crack damage were from studies conducted by the authors and their colleagues with many federal, state and local organizations of highway, railroad and rapid transit, with numerous engineering design and consulting companies, and with bridge fabrication and construction companies. The opportunity to work with all these engineers is appreciated.

A number of graduate students assisted in various parts of formulating and completing this manual. Their contributions are acknowledged.

Dr. Roger G. Slutter, a member of the team, passed away in July 1989 while this manual was in the final stage of being compiled. His contribution is greatly valued.

REFERENCES

1. Fisher, J. W.
Inspecting Steel Bridges for Fatigue Damage,
Pennsylvania Department of Transportation Report No. 72-3 FHWA/PA-81/005,
Fritz Engineering Laboratory Report 368-15(81), March 1981.
2. Fisher, J.W., Mertz, D.R. and Zhong, A.
Steel Bridge Members under Variable Amplitude, Long Life Fatigue Loading,
NCHRP Report 267, 1983.
3. Keating, P.B. and Fisher, J.W.
Evaluation of Fatigue Tests and Design Criteria on Welded Details, NCHRP
Report 286, Sept. 1986.
4. Paulson, C. Jr., Frank, K.H. and Breen, J.E.
A Fatigue Study of Prestressing Strand, Research Report 300-1, Center for
Highway Research, University of Texas at Austin, April 1983.
5. Overman, T.R., Breen, J.E. and Frank, K.H.
Fatigue Behavior of Pretensioned Concrete Girders, Research Report 300-2F,
Center for Highway Research, University of Texas at Austin, Nov. 1984.
6. Keating, P.B., Halley, S.A. and Fisher, J.W.
Fatigue Test Database for Welded Steel Bridge Details, Fritz Engineering
Laboratory Report 488.2(86), May 1986.
7. Demers, C.E., and Fisher, J.W.
A Survey of Localized Cracking in Steel Bridges, 1981-1988
ATLSS Report 89-01, NSF-ERC Advanced Technology for Large Structural
Systems, Lehigh University; Federal Highway Administration Research Report
FHWA-RD-89-166, July 1989.
8. American Association of State Highway and Transportation Officials,
AASHTO Standard Specifications for Highway Bridges, 14th edition, 1989.
9. Department of Transportation, Federal Highway Administration.
Bridge Inspector's Training Manual. U.S. Government Printing Office, 1971.
10. American Association of State Highway and Transportation Officials,
AASHTO Manual for Maintenance Inspection of Bridges, 1983, with
supplements 1984 to 1987. (Being revised 1989)

11. OECD Road Research Group,
Bridge Inspection, Director of Information, OECD, 2 rue Andre-Pascal, 75775
Paris, France, 1976.
12. Byrd, Tallamy, MacDonald and Lewis
Inspection of Fracture Critical Bridge Members, Manual and Participant
Notebook, prepared for the Federal Highway Administration, 1986.
13. Pennsylvania Department of Transportation
Guidelines for Fatigue and Fracture Safety Inspection of Bridges, 1988
14. Timoshenko, S. and Young, D.H.
Elements of Strength of Material, D. Van Nostrand Co., Inc. Fourth Edition,
1962.
15. Fisher, J.W.
Bridge Fatigue Guide, Design and Details
American Institute of Steel Construction, New York, N.Y. 1977.
16. Barsom, J.M. and Rolfe, S. T.
Fracture and Fatigue Control in Structures, Prentice-Hall Inc., New York, NY,
1987.
17. Hertzberg, R.W.
Deformation and Fracture Mechanics of Engineering Materials, John Wiley & Sons,
New York, NY, 1983.
18. Fisher, J.W., Frank, K.H., Hirt, M.A., and McNamee, B.M.
Effects of Weldments on the Fatigue Strength of Steel Beams,
NCHRP Report 102, 1970.
19. Fisher, J.W.
Fatigue and Fracture of Steel Bridges, Case Studies
John Wiley and Sons, 1984.
20. Fisher, J.W. Pense, A.W., Hausammann, H. and Irwin, G.R.
Quinnipiac River Bridge Cracking
ASCE Proceedings, Vol. 106, EM 1, April 1980.
21. Fisher, J.W. and Pense, A.W.
Final Report on Mianus River Bridge Material, Fracture Surface and Special Tests.
(Zetlin-Argo Structural Investigations Inc. and Connecticut Department of
Transportation), June 1984.
22. Helgalson, T., Hanson, J.M., Somes, N.F., Corely, W.G. and Hognestad, E.
Fatigue Strength of High-Yield Reinforcing Bars, NCHRP Report 164,
Transportation Research Board, National Research Council, Washington, D.C.,
1976.

23. American Concrete Institute.
Analysis and Design of Reinforced Concrete Bridge Structures, ACI-ASCE
Committee 343 Report, (ACI343R-88), 1988.
24. Warner, R.F. and Hulsbos, C.L.
Probable Fatigue Life of Prestressed Concrete Beams, Journal of the Prestressed
Concrete Institute, April, 1966.
25. Hanson, J. M., Hulsbos, C.L. and VanHorn, D.A.
Fatigue Test of Prestressed Concrete I-Beams, Journal of the Structural
Division, ASCE, ST11, Nov. 1970.
26. Rabbat, B., Karr, P.H., Russell, H.G., Bruce, R.N., Jr.
Fatigue Tests of Pretensioned Girders with Blanketed and Draped Strands,
Journal of the Prestressed Concrete Institute, Vol. 24, No. 4, July-Aug., 1979.
27. American Association of State Highway and Transportation Officials.
AASHTO Standard Specification for Highway Bridges, 1965. 9th Edition.
28. Dowling, N.E.
Fatigue Failure Predictions for Complicated Stress-Strain Histories, Journal of
Materials 7(1):71-87, March, 1972.
29. Woodward, H. M. and Fisher, J.W.
Predictions of Fatigue Failure In Steel Bridges, Fritz Engineering Laboratory
Report 386-12, , 1980.
30. Schilling, C.G., Klippstein, K.H, Barsom, J.M. and Blake, G.T.
Fatigue of Welded Steel Bridge Members Under Variable-Amplitude Loadings,
NCHRP Report 188. Transportation Research Board, 1978.
31. Fisher, J.W., Yen, B.T., Wang, D. and Mann, J.E.
Fatigue and Fracture Evaluation for Rating Riveted Bridges, Fritz Engineering
Laboratory Report No. 499.3, Bethlehem, PA 1988; NCHRP Report No. 302,
Transportation Research Board, December 1987.
32. Fisher, J.W., Yen, B.T. and Wang, D.
Fatigue of Bridge Structures - A Commentary and Guide for Design, Evaluation and
Investigation of Cracking, ATLSS Report No. 89-02, NSF-ERC Advanced Technology
for Large Structural Systems, Lehigh University, Federal Highway Administration
Research Report FHWA-RD-89-167.
33. Moses, F., Schilling, C.G. and Raju, K.S.
Fatigue Evaluation Procedures for Steel Bridges, NCHRP Report No. 299,
Transportation Research Board, December 1987.

APPENDICES

Appendix A Fatigue Design Provisions (Excerpted from AASHTO Bridge Specification, 1989 edition).

Appendix B Notes on Locations where Fatigue Cracks are likely to Occur.

Appendix C Summary of Types of Details Experiencing Cracking

Table A1. Allowable Fatigue Stress Ranges

Redundant Load Path Structures*				
Category (See Table 10.3.1B)	Allowable Range of Stress, F_{sr} (ksi) ^a			
	For 100,000 Cycles	For 500,000 Cycles	For 2,000,000 Cycles	For over 2,000,000 Cycles
A	63	37	24	24
B	49	29	18	16
B'	39	23	14.5	12
C	35.5	21	13	10 12 ^b
D	28	16	10	7
E	22	13	8	4.5
E'	16	9.2	5.8	2.6
F	15	12	9	8

Nonredundant Load Path Structures				
Category (See Table 10.3.1B)	Allowable Range of Stress, F_{sr} (ksi) ^a			
	For 100,000 Cycles	For 500,000 Cycles	For 2,000,000 Cycles	For over 2,000,000 Cycles
A	50	29	24	24
B	39	23	16	16
B'	31	18	11	11
C	28	16	10 12 ^b	9 11 ^b
D	22	13	8	5
E ^c	17	10	6	2.3
E'	12	7	4	1.3
F	12	9	7	6

* Structure types with multi-load paths where a single fracture in a member cannot lead to the collapse. For example, a simply supported single span multi-beam bridge or a multi-element eye bar truss member has redundant load paths.

^a The range of stress is defined as the algebraic difference between the maximum stress and the minimum stress. Tension stress is considered to have the opposite algebraic sign from compression stress.

^b For transverse stiffener welds on girder webs or flanges.

^c Partial length welded cover plates shall not be used on flanges more than 0.8 inches thick for nonredundant load path structures.

Table A2. Fatigue Categories of Bridge Details

General Condition	Situation	Kind of Stress	Stress Category (See Table 10.3.1A)	Illustrative Example (See Figure 10.3.1C)
Plain Member	Base metal with rolled or cleaned surface. Flame-cut edges with ANSI smoothness of 1.000 or less.	T or Rev ^a	A	1,2
Built-Up Members	Base metal and weld metal in members of built-up plates or shapes (without attachments) connected by continuous full penetration groove welds (with backing bars removed) or by continuous fillet welds parallel to the direction of applied stress.	T or Rev	B	3,4,5,7
	Base metal and weld metal in members of built-up plates or shapes (without attachments) connected by continuous full penetration groove welds with backing bars not removed, or by continuous partial penetration groove welds parallel to the direction of applied stress.	T or Rev	B'	3,4,5,7
	Calculated flexural stress at the toe of transverse stiffener welds on girder webs or flanges.	T or Rev	C	6
	Base metal at ends of partial length welded coverplates narrower than the flange having square or tapered ends, with or without welds across the ends, or wider than flange with welds across the ends:			
	(a) Flange thickness \leq 0.8 in.	T or Rev	E	7
	(b) Flange thickness $>$ 0.8 in.	T or Rev	E'	7
Groove Welded Connections	Base metal at ends of partial length welded coverplates wider than the flange without welds across the ends.	T or Rev	E'	7
	Base metal and weld metal in or adjacent to full penetration groove weld splices of rolled or welded sections having similar profiles when welds are ground flush with grinding in the direction of applied stress and weld soundness established by nondestructive inspection.	T or Rev	B	8,10
	Base metal and weld metal in or adjacent to full penetration groove weld splices with 2 ft. radius transitions in width, when welds are ground flush with grinding in the direction of applied stress and weld soundness established by nondestructive inspection.	T or Rev	B	13
	Base metal and weld metal in or adjacent to full penetration groove weld splices at transitions in width or thickness, with welds ground to provide slopes no steeper than 1 to 2½, with grinding in the direction of the applied stress, and weld soundness established by nondestructive inspection:			
	(a) A514/A517 base metal	T or Rev	B'	11,12
	(b) Other base metals	T or Rev	B	11,12
	Base metal and weld metal in or adjacent to full penetration groove weld splices, with or without transitions having slopes no greater than 1 to 2½, when the reinforcement is not removed and weld soundness is established by nondestructive inspection.	T or Rev	C	8,10,11,12
Groove Welded Attachments—Longitudinally Loaded ^b	Base metal adjacent to details attached by full or partial penetration groove welds when the detail length, L, in the direction of stress, is less than 2 in.	T or Rev	C	6,15
	Base metal adjacent to details attached by full or partial penetration groove welds when the detail length, L, in the direction of stress, is between 2 in. and 12 times the plate thickness but less than 4 in.	T or Rev	D	15

Table A2. Fatigue Categories of Bridge Details (Contd.)

General Condition	Situation	Kind of Stress	Stress Category (See Table 10.3.1A)	Illustrative Example (See Figure 10.3.1C)
	Base metal adjacent to details attached by full or partial penetration groove welds when the detail length, L , in the direction of stress, is greater than 12 times the plate thickness or greater than 4 in.:			
	(a) Detail thickness < 1.0 in.	T or Rev	E	15
	(b) Detail thickness ≥ 1.0 in.	T or Rev	E'	15
	Base metal adjacent to details attached by full or partial penetration groove welds with a transition radius, R , regardless of the detail length:			
	—With the end welds ground smooth	T or Rev		16
	(a) Transition radius ≥ 24 in.		B	
	(b) 24 in. $>$ Transition radius ≥ 6 in.		C	
	(c) 6 in. $>$ Transition radius ≥ 2 in.		D	
	(d) 2 in. $>$ Transition radius ≥ 0 in.		E	
	—For all transition radii without end welds ground smooth.	T or Rev	E	16
Groove welded Attachments—Transversely Loaded ^{b,c}	Detail base metal attached by full penetration groove welds with a transition radius, R , regardless of the detail length and with weld soundness transverse to the direction of stress established by nondestructive inspection:			
	—With equal plate thickness and reinforcement removed	T or Rev		16
	(a) Transition radius ≥ 24 in.		B	
	(b) 24 in. $>$ Transition radius ≥ 6 in.		C	
	(c) 6 in. $>$ Transition radius ≥ 2 in.		D	
	(d) 2 in. $>$ Transition radius ≥ 0 in.		E	
	—With equal plate thickness and reinforcement not removed	T or Rev		16
	(a) Transition radius ≥ 6 in.		C	
	(b) 6 in. $>$ Transition radius ≥ 2 in.		D	
	(c) 2 in. $>$ Transition radius ≥ 0 in.		E	
	—With unequal plate thickness and reinforcement removed	T or Rev		16
	(a) Transition radius ≥ 2 in.		D	
	(b) 2 in. $>$ Transition radius ≥ 0 in.		E	
	—For all transition radii with unequal plate thickness and reinforcement not removed.	T or Rev	E	16
Fillet Welded Connections	Base metal at details connected with transversely loaded welds, with the welds perpendicular to the direction of stress:			
	(a) Detail thickness ≤ 0.5 in.	T or Rev	C	14
	(b) Detail thickness > 0.5 in.	T or Rev	See Note ^d	
	Base metal at intermittent fillet welds.	T or Rev	E	—
	Shear stress on throat of fillet welds.	Shear	F	9
Fillet Welded Attachments—Longitudinally Loaded ^{b,c,e}	Base metal adjacent to details attached by fillet welds with length, L , in the direction of stress, is less than 2 in. and stud-type shear connectors.	T or Rev	C	15.17.18.20
	Base metal adjacent to details attached by fillet welds with length, L , in the direction of stress, between 2 in. and 12 times the plate thickness but less than 4 in.	T or Rev	D	15.17
	Base metal adjacent to details attached by fillet welds with length, L , in the direction of stress greater than 12 times the plate thickness or greater than 4 in.:			
	(a) Detail thickness < 1.0 in.	T or Rev	E	7.9.15.17
	(b) Detail thickness ≥ 1.0 in.	T or Rev	E'	7.9.15

Table A2. Fatigue Categories of Bridge Details (Contd.)

General Condition	Situation	Kind of Stress	Stress Category (See Table 10.3.1A)	Illustrative Example (See Figure 10.3.1C)
	Base metal adjacent to details attached by fillet welds with a transition radius, R, regardless of the detail length:			
	—With the end welds ground smooth	T or Rev	D	16
	(a) Transition radius ≥ 2 in.		E	
	(b) 2 in. > Transition radius ≥ 0 in.			
	—For all transition radii without the end welds ground smooth.	T or Rev	E	16
Fillet Welded Attachments— Transversely Loaded with the weld in the direction of principal stress ^{b,c}	Detail base metal attached by fillet welds with a transition radius, R, regardless of the detail length (shear stress on the throat of fillet welds governed by Category F):			
	—With the end welds ground smooth	T or Rev	D	16
	(a) Transition radius ≥ 2 in.		E	
	(b) 2 in. > Transition radius ≥ 0 in.			
	—For all transition radii without the end welds ground smooth.	T or Rev	E	16
Mechanically Fastened Connections	Base metal at gross section of high strength bolted slip resistant connections, except axially loaded joints which induce out-of-plane bending in connecting materials.	T or Rev	B	21
	Base metal at net section of high strength bolted bearing-type connections.	T or Rev	B	21
	Base metal at net section of riveted connections.	T or Rev	D	21

^a“T” signifies range in tensile stress only, “Rev” signifies a range of stress involving both tension and compression during a stress cycle.

^b“Longitudinally Loaded” signifies direction of applied stress is parallel to the longitudinal axis of the weld. “Transversely Loaded” signifies direction of applied stress is perpendicular to the longitudinal axis of the weld.

^cTransversely loaded partial penetration groove welds are prohibited.

^dAllowable fatigue stress range on throat of fillet welds transversely loaded is a function of the effective throat and plate thickness. (See Frank and Fisher, Journal of the Structural Division, ASCE, Vol. 105, No. ST9, Sept. 1979.)

$$S_r = S_C \left(\frac{0.06 - 0.79H/t_p}{1.1t_p^{1/20}} \right)$$

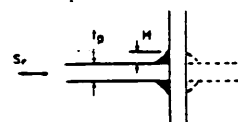

where S_C is equal to the allowable stress range for Category C given in Table 10.3.1A. This assumes no penetration at the weld root.

^eGusset plates attached to girder flange surfaces with only transverse fillet welds are prohibited.

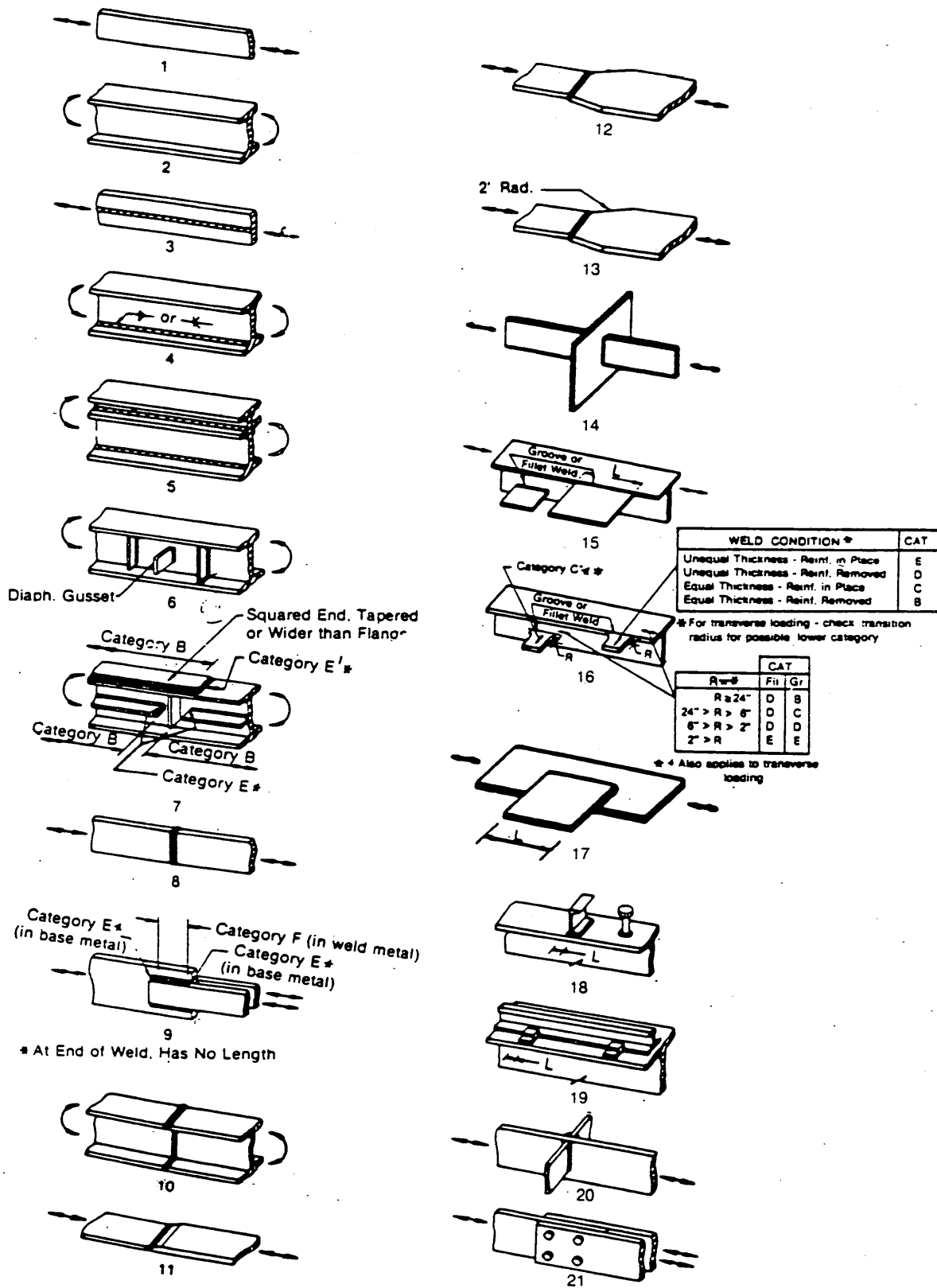

Figure A1. Illustrative Examples of Bridge Details

Appendix B

NOTES ON LOCATIONS WHERE FATIGUE CRACKS ARE LIKELY TO OCCUR

A. Groove Welds

1. Flange Groove Welds:

Reltively older structures with groove welds in flanges made prior to adequate nondestructive inspection.

2. Web Groove Welds:

Same comments as for A1.

3. Groove Welds in Longitudinal Stiffeners:

Longitudinal stiffeners on girder webs are structural components and the welds should be treated as structural welds. Older bridges seldom had these connections inspected.

4. Groove Welds Between Longitudinal Stiffeners and Intersecting Members:

Often lack of fusion exists in the transverse weld connection
This is particularly acute when no cope exists at the web

B. End of Welded Cover Plates on Flanges of Beams and Girders

1. Cover Plates with End Welds:

Crack develops at toe of weld or in throat of weld most likely at midwidth of flange.

2. Cover Plates without End Welds:

Cracks develop at end of longitudinal weld at the end of cover plate
(and near flange tip)

C. Ends of Various Reinforcement or Attachment Plates, Welded on Girder Flange or Web or on Truss Members

1. Welded Splices between Adjacent Parts; Lateral Gusset Plates:

These are equivalent to cover plates

2. Repairs Using Welded Doubler Plates:

These are also equivalent to cover plates if more than 8 in. long.

3. Attachments for Signs, Railings, Light Fixtures and other Fittings with the Attachment Plate Parallel to the Bridge Members:

If the attachment plate is more than 8 in. long, it is equivalent to a cover plate.

4. Welded Attachment Plates Perpendicular to the Direction of the Bridge Member:

These have higher resistance to fatigue than details described in C1 and C3.

D. Diaphragm Connections in Girder Bridges

1. Ends of Welded Diaphragm Connection Plates on Girder Webs where the Connection Plate is not Welded to the Flange:

Cracks may occur at the gap (cope), either horizontal along the web-to-flange weld, or at the top of web-to-connection plate weld. These cracks can occur at the upper and lower end of the connection plate when no positive attachment is made to the flange.

2. Ends of Riveted Diaphragm Connection Angles on Girder Webs where the Angles are not Connected to the Flange:

Cracks may occur in the web horizontal along the flange, or in the angles vertically, or in the first (highest or lowest) rivets. The web cracks are most likely when connections angles do not overlap the flange angles. Also, rivet heads or bolts may crack from prying.

E. End Connections of Floor Beams or Diaphragms

1. Copes and Blocked Flanges at Ends of Floor Beams:

Cracks may occur at the re-entrant angle of the cope or the blocked flange, particularly when the re-entrant angle is flame cut, with re-entrant notches.

2. Connection Plates and Angles may have cracks, similar to those described in D above.

F. Floor Beam Brackets

1. Bracket Connections to Girder Webs:

These are similar to diaphragm connections of Item D above.

2. Tie Plates between top flange of Outrigger Brackets and the Floor Beams:
Cracks may develop from edge or rivet holes of these plates if connected to top flange of longitudinal girder.

Relative movement also results in web cracks in the floor beam and bracket webs.

G. Stringer to Floor Beam Connections

1. Crack in Cope (see E1)

2. Crack in Connection (see D)

H. Lateral (Wind) Bracing Connections to Girders

1. Gusset Plates Welded to Girder Web or Flange:

These plates are welded attachments (see C3). These gussets are also force-transmitting connection plates. When the gusset plate is attached to the web but not connected to the diaphragm connection plate, cracks may occur in the web gap, at the toe of the weld.

2. Gusset plate to Diaphragm connection Plate Welds:

These welds are often groove welds similar to those described in A4 but are subjected to more forces. If the welds joining the gusset to the web and the welds joining the gusset to the diaphragm connection plate intersect, high restraint develops in the region. The probability of defects in the high restraint region increases the possibility of fatigue crack growth. Special attention should be given these types of details.

I. Transverse Stiffeners

1. These intermediate stiffeners are not connection plates for diaphragms or floor beams. These stiffener plates are transverse attachments normally with adequate fatigue strength (C4).

2. Occasionally cracks may occur at the ends of cut-short intermediate stiffeners, due to handling or transportation during fabrication and construction. Excessive web plate vibration may also result in cracking. At fitted stiffeners, movement can be revealed by the paint film.

J. Box Girder Diaphragms and Connections

1. Connection plates for X or K-Type Interior and Exterior Diaphragms:

These connection plates are load-carrying members. Cracks may occur at the ends of the connection plates in the web gaps, as described in D1.

2. Interior Plate Diaphragms Which are not Connected to the Tension Flange:

Cracks may develop in the web at the gap between the diaphragms and the flange.

3. Floor Beam Connections to Box Girder Webs:

Cracks may occur at copes or at connection plate or angle (see D and E).

4. Girder Connection to the Pier Cap Box Girder:

Same comment as for J3 above (see D and E).

K. Truss Bridge Floor Beams

1. Connection of Floor Beam to Verticals:

Cracks may develop in connection angles, at rivet or bolt heads (D2) or at copes (E1).

2. Connection of Lateral (Wind) Bracing to Floor Beams:
Cracks may occur in horizontal gussets connecting the laterals to the floor beam flanges, or in the flange or web of the floor beam, often near bridge bearings.

L. Truss Bridge Verticals and Diagonals

1. Verticals near Bridge Ends:
Cracks may occur in the first vertical member, at the top near the gusset plate or in the gusset plate usually starting from a rivet hole. Cracks may also occur near the floor beam connection.
2. Verticals and Diagonals which are Eyebars:
These flat eyebars with enlarged heads may develop cracks at the pin holes when a forge lap exists. Crack may also occur at the transition from the shank to the head when the bar edge is flame cut.

M. Pin-Connected Links or Hangers of Multispan Bridges

1. Eyebars Links:
Cracks may occur at the edge of pin holes, at the width transition, or at the edge of bar (see L2).
2. Hanger Plates:
These plates are similar to eyebars links, but without reduction of width. Cracks may occur at the pin holes or at the edge of plate.
3. Most pin-connected links and hanger plates are subjected to in-plane bending, because the pins are not frictionless. Extra attention should be given to these links if corrosion and fixity is apparent.

N. Tack Welds

1. Tack welds which were used for attaching bridge components during construction and erection are often sources of fatigue cracks.
2. Tack welds between gussets and main members, between bearing plates and beam flanges, between floor beam top flanges and outrigger bracket tie plates, between riveted and bolted connection angles and webs etc. are examples.

STEEL BRIDGE SUPERSTRUCTURE SUSCEPTIBILITY TO
COMPLETE FAILURE DUE TO FATIGUE CRACKING AND BRITTLE FRACTURE

1. **Suspended Spans with Two Girders:**
Links and hangers and the connecting pins are susceptible to fatigue cracking; pack rust can push hangers off pins.
2. **Bar-Chain Suspension Bridge with Two Eyebars Per Panel:**
Fracture critical condition depends on the ability of a single eyebar and the joint at panel point to resist loads.
3. **Welded Tie Arches with Box Shaped Tie Girder:**
Partial length cover plates, diaphragm and floor beam connections, or details with low fatigue strength may be subject to fatigue crack growth and subsequent brittle fracture.
4. **Simple Span Truss with Two Eyebars or Single Member between Panel Points:**
If the floor system is rigidly connected to the verticals (hangers), redistribution of forces can take place, but bridge deflection would be excessive.
5. **Simple Span Single Welded Box Girders with Category E Details:**
Fatigue cracks develop at details such as termination of longitudinal stiffeners or gusset plate could lead to fracture of the box, but fatigue crack growth would normally be at moderate rate, thus allowing time for inspection.
6. **Simple Span Two Girder Bridges with Welded Partial Length Cover Plates on the Bottom Flange:**
The floor system, including the deck and the lateral bracing members, provides alternative load paths and redundancy, but deck deflection would be excessive.
7. **Continuous Span Two Girder System with Cantilever and Suspension Link Arrangement and Welded Partial Length Cover Plates:**
Fracture of a girder will increase deflection, and this can be excessive.
8. **Simple Span Two Girder System with Lateral Bracing Connected to Horizontal Gusset Plates which are Attached to Webs:**
Differential forces in laterals could cause fatigue cracks in girder web at the ends of the gusset plate, particularly when the gusset plate is not attached to the floor beam or diaphragm connection plate. The vertical crack would grow toward the tension flange and may cause brittle fracture.
9. **Single Welded I-Girder or Box Girder Pier Cap with Bridge Girders and Stringers Attached by Welding:**
Multigirders or stringers with bridge deck may permit redistribution of forces. Adverse details such as penetration of the pier cap web with a girder flange can result in cracking.

Appendix C: Summary of Types of Details Experiencing Cracking

TABLE 1: SUMMARY OF TYPES OF DETAILS EXPERIENCING CRACKING

<u>Detail</u>	<u>Initial Defect or Condition</u>	<u>Number of Bridges</u>	<u>Fatigue Category</u>
1. Eyebars	Stress Corrosion	1	Initial Crack
	Forge Laps, Unknown Defects	12	
2. Anchorage Eyebars	Corrosion Notching & Pin Fixity	1	
3. Pin & Hanger Assemblies	Frozen Pins	2	Out-of-plane
	Other	1	D
	Partial Bearing	1	Corrosion Packout
	Pin Fixity (corrosion packout)	1	Rivet Hole
5. Verticals (Hangers) (Truss & Arches)	Vibration-Wind	4	Aeroelastic Instability
6. Coverplated Beams	Normal Weld Toe	5	E'
	Fabrication Cracks	1	<E'
7. Flange Gussets	Weld Toe	8	E or E'
8. Web Gusset	Intersecting Welds	6	<E'
	Weld Termination	2	<E
	Gap between Stiffener & Gusset	7	Out-of-plane
9. Gusset Plates	Lateral Bracing Vibration	3	Out-of-plane
10. Flange or Web Groove	Lack of Fusion	7	Large Initial Crack
11. Coverplate Groove Welds	Lack of Fusion	4	Large Initial Crack
12. Web-Flange Fillet Weld at Curved Haunch	Lack of Fusion	1	Initial Crack
13. Web-Flange Welds	Transverse Weld Cold Cracks or Internal Flaws	2	Initial Crack
14. Box Girder Beam to Box Girder Column Welds	Lack of Fusion in Closure Plates	1	Initial crack
15. Box Girder Corner Welds	Transverse Weld Cold Cracks	3	Large Initial Crack
16. Web Gap Distortion at Internal Diaphragm	Lack of Fusion at Back-up Bar	2	Initial Crack
17. Longitudinal Stiffeners	Lack of fusion, poor weld	8	Large Initial Crack
	Weld Termination	1	<E
	Web Gap	1	Out-of-plane

TABLE 1: SUMMARY OF TYPES OF DETAILS EXPERIENCING CRACKING (CONT'D)

18. Electroslag Welds	Various Flaws	6	
19. Plug Welds	Crack	1	
20. Welded Repair	Lack of Fusion, Weld Termination	3	<E
21. Welded Web Inserts	Lack of fusion	2	Large Initial Crack
22. Welded Holes	Lack of Fusion	3	Large Initial Crack
23. Flanges & Brackets through Web	Flange Tip Crack	3	<E'
24. Rivet Head	Prying	2	Prying
25. Lamellar Tearing	Restraint	2	
26. Bearing Stiffener	Web Buckling	1	Out-of-plane
27. Girder Web	Welding Discontinuities at Temporary Attachment	1	<E
28. Double Connection Angles	Restraint in Connection	2	Out-of-plane
29. Back-up Bar	Back-up Bar Butt Splice, Lack of Fusion	2	<E'
30. Transverse Stiffeners	Shipping and Handling Web Gap	8 1	Out-of-plane Out-of-plane
31. Floorbeam Connection Plates	Welded Girder Web Gaps Riveted Web Gaps	31 1	Out-of-plane Out-of-plane
32. Floorbeam & Cantilever Bracket Connection Plates	Restraint	4	Out-of-plane
33. Floorbeam & Cantilever Bracket Webs at Connection Plates	Web Gap Welded Vertical Connection Plate	3 1	Out-of-plane Out-of-plane
34. Diaphragm Connection Plates	Lack of Fusion Web Weld Web Gaps Box Girder Web Gaps	3 18 7	Initial Crack Out-of-plane Out-of-plane

TABLE 1: SUMMARY OF TYPES OF DETAILS EXPERIENCING CRACKING (CONT'D)

35. Diaphragm & Floorbeam Connection Plates at Piers	Web Gaps	4	Restraint
36. Box Girder Flange-Diaphragm Connection Plate Weld	Lack of Fusion, Weld Termination, Poor Quality Welds	1	<E'
37. Stringer-Floorbeam Brackets	Web Gap	4	Out-of-plane
38. Stringer End Connections	Restraint	3	Weld Termination
39. Tied Arch Floor Beams	Web Gaps	8	Out-of-plane
40. Tied Arch Floor Beam Connections	Weld Root	2	Restraint
41. Coped Members	Notch & Restraint	21	Flame Cut Edge
	Notch & Restraint	2	Out-of-plane
42. Compression Flange Attachment	Cross Bending of Flange	1	E'
43. Compression Flange-Diaphragm Connection Plate Welds & Weld Toe	Overstressed Weld	2	Residual Stress