

1973

Hydraulic performance of pennsylvania highway drainage inlets installed in grassed channels (Type H, Type 4 Ft.& Type 6-Ft.), January 1973 Final Reprint PB229605

Erik Appel

A. W. Brune

W. H. Graf

Follow this and additional works at: <http://preserve.lehigh.edu/engr-civil-environmental-fritz-lab-reports>

Recommended Citation

Appel, Erik; Brune, A. W.; and Graf, W. H., "Hydraulic performance of pennsylvania highway drainage inlets installed in grassed channels (Type H, Type 4 Ft.& Type 6-Ft.), January 1973 Final Reprint PB229605" (1973). *Fritz Laboratory Reports*. Paper 425. <http://preserve.lehigh.edu/engr-civil-environmental-fritz-lab-reports/425>

This Technical Report is brought to you for free and open access by the Civil and Environmental Engineering at Lehigh Preserve. It has been accepted for inclusion in Fritz Laboratory Reports by an authorized administrator of Lehigh Preserve. For more information, please contact preserve@lehigh.edu.

The geometry of the inlet grating was of no particular consequence in most tests. The three gratings considered for the Type H Inlet had approximately equal efficiencies except at the steep slope of 8%; however the difference was minor, only 10%. The steepest grade, 8%, had a lower efficiency than any flatter grade, but the reduction in efficiency was merely 10%.

The grating for the Type 6-Ft Inlet was 10% to 20% more efficient than that for the Type 4-Ft Inlet for identical channel configurations, probably owing to its greater length. For both gratings a swale slope of 6:1 increased the efficiency as much as 20% over that at a slope of 12:1. Depressing either prototype inlet as much as 2 inches was of no real significance in improving its efficiency.

An inlet installed at the bottom of a vertical curve will be subjected to a sump condition occasionally. Tests have shown that ponding occurs under extremely high rates of flow only, and not necessarily for each inlet grating tested.

One aspect of this study was to determine the efficacy of constructing a dike downstream from an inlet that is installed in a median. The data obtained clearly show that a dike significantly increases the capacity of an inlet, and that increase is not merely a percentage; rather the increase, depending upon the channel configuration, ranges from 2 to 5 times the capacity of an inlet without a dike. Obviously, then, the practice of constructing a dike downstream from an inlet in a median is advantageous and is highly desirable for grades of 0.5% and upward. However the dike led to the formation of a strong vortex at the downstream end of the grating, indicating that substantial scour could occur in the field.

364.4

ASCE Annual and National Environmental Engineering Convention

October 21-25, 1974

Kansas City, Mo.
\$0.50



FRITZ ENGINEERING
LABORATORY LIBRARY

HYDRAULIC PERFORMANCE OF HIGHWAY INLET GRATINGS

Arthur W. Brune, Walter H. Graf,
Erik Appel, and Peter P. Yee

Meeting Preprint 2390

below the invert in the prototype; the results indicated no difference of consequence among the three conditions.

In general, the efficiencies of the Type 6-Ft Inlet grating for a particular channel configuration are 10% to 20% higher than the corresponding efficiencies of the Type 4-Ft Inlet grating. The slopes of the efficiency curves for the Type 6-Ft Inlet grating are slightly flatter than those of the Type 4-Ft Inlet grating, indicating the ability of the larger grating to intercept relatively more water.

A dike was installed downstream of the Type 4-Ft and the Type 6-Ft Inlet gratings to determine the efficacy thereof. Such a dike improved the capacities of the gratings significantly, that is, by 2 to 5 times. However, for channel configurations where the side slopes differed from each other, a very strong vortex with high velocities developed on top of the downstream end of the inlet gratings indicating that substantial scour could occur at a field installation. No dike was used in the tests of gratings installed in paved channels.

A test for sump effect from water flowing in both directions toward an inlet showed that water covers a grating only under extremely high rates of flow, from 25 to 34 cfs, depending on the particular grating.

CONCLUSIONS

Experiments on the hydraulic performance of six different types of gratings for drainage inlets installed by the Pennsylvania Department of Transportation in paved or grassed channels were conducted in a model. The effects of different slopes, sides and longitudinal, of the channel were investigated.

The efficiency of an inlet grating placed in a channel with fixed side slopes decreases with increasing longitudinal slope.

The efficiency of a particular grating increases significantly with increasing swale slope and is maximal if the back slope is equal to the swale slope.

This preprint has been provided for the purpose of convenient distribution of information at the convention. To defray, in part, the cost of printing, a meeting price of 50¢ to all registrants has been established. The post-convention price, when ordered from ASCE headquarters will be 50¢ while the supply lasts. For bulk orders (of not less than 200 copies of one preprint) please write for prices.

No acceptance or endorsement by the American Society of Civil Engineers is implied; the Society is not responsible for any statement made or opinion expressed in its publications.

Reprints may be made on condition that the full title, name of author, and date of preprinting by the Society are given.

HYDRAULIC PERFORMANCE OF HIGHWAY INLET GRATINGS

By Arthur W. Brune¹, M ASCE, Walter H. Graf², M ASCE

Erik Appel³, and Peter P. Yee⁴, AM ASCE

INTRODUCTION

Design and spacing of a grating for a drainage inlet have been governed by several factors, such as (1) the assumed capacity of an inlet based on past experience, (2) the structural strength of the inlet grating, (3) the effect of the inlet on traffic, (4) the effect of the grating on pedestrians, and (5) the costs of installation and maintenance. Designers commonly assume that an inlet has a certain capacity regardless of the channel configuration of the drainage channel, and little attention is paid to the carryover at an inlet; carryover is the water that bypasses the drainage inlet. Obviously, the capacity of any drainage inlet and its grating must be thoroughly understood if the spacing of inlets is to be set forth on a sound basis.

Investigations of the performances of drainage inlets have been conducted amongst others by LARSON and others (1949), by GUILLOU (1959), by personnel at JOHN HOPKINS UNIVERSITY (1956), and by the U S ARMY CORPS OF ENGINEERS (1946). An extensive survey of the literature was made by YUCEL and others (1969) as part of the study here presented; however little of the information obtained in that survey was suitable for the present study owing to the differences between the inlets examined by the other investigators.

1 Associate Professor, Department of Civil Engineering, Lehigh University, Bethlehem, Pa.

2 Laboratoire D'Hydraulique, Ecole Polytechnique, Lausanne, Switzerland

3 Peter Bangsvej, Valby, Copenhagen, Denmark

4 Dept of Environmental, Water Planning and Management Branch, Burlington, Ontario

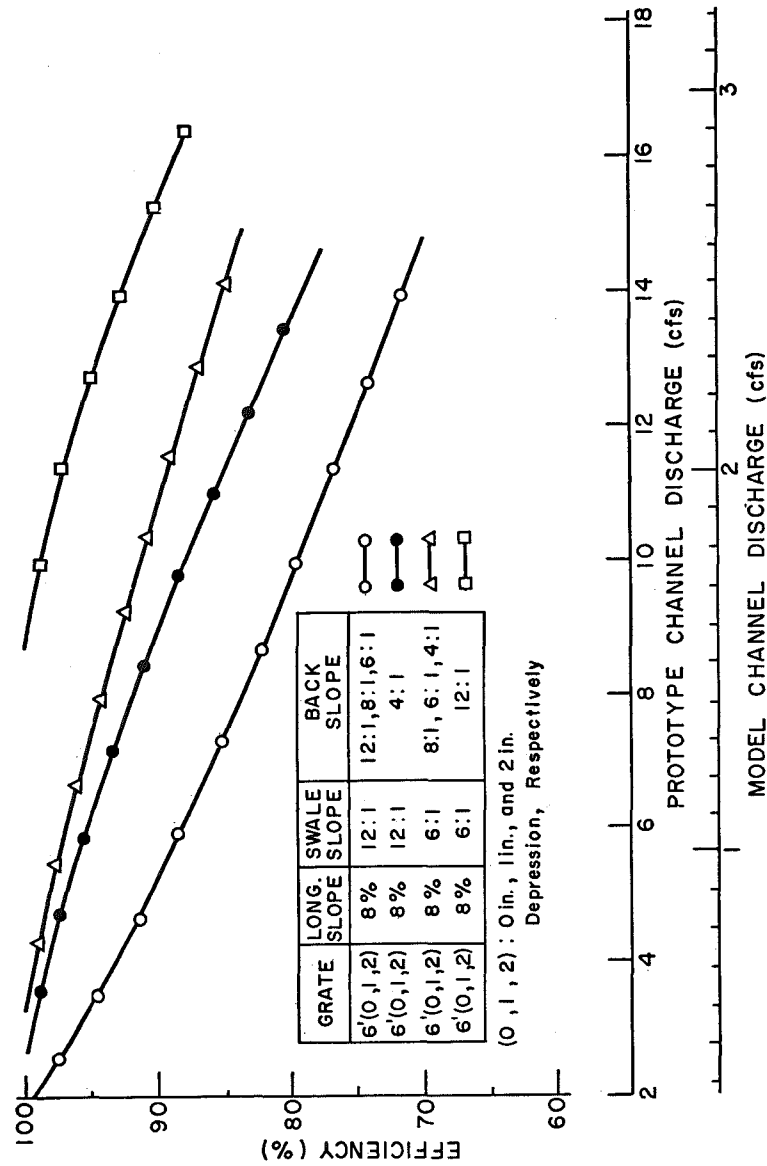

Fig. 15 Efficiency Curves for Type 6-Ft Inlet Grating (Long. Slope 8%)

This study deals primarily with determining the capacity and efficiency of inlet gratings by testing models of the gratings. Six standard drainage inlets used by the Pennsylvania Department of Transportation were tested in the Fritz Engineering Laboratory of Lehigh University under a variety of conditions. Inlets customarily installed in paved channels are the Type 4-Ft Special, the Type 6-Ft Special, and the Type J. The Type H, the Type 4-Ft, and the Type 6-Ft Inlets are installed in grassed channels. (See Figs. 3 to 8)

Each grating was modeled according to the specifications of PennDOT and was tested under channel conditions and channel flow rates described later; each model was built with a prototype:model length ratio of 2:1.

MODEL LAWS

The main purpose in modeling is to correlate model behavior to prototype behavior by means of the basic principles of similitude. Knowing the proper prototype:model scale ratio, measurements in the model can be translated into different quantities in the prototype, such as velocity or discharge.

Factors considered in establishing the length ratio of 2:1 were the space available for testing a model, the maximal discharge available in the laboratory, the cost of fabricating the model, and operating the model.

Hydraulic Similitude and Dimensionless Numbers

In order to correlate flow phenomena between model and prototype, three types of similitudes are involved; they are geometric, kinematic, and dynamic. If complete similarity is desired between model and prototype, all three must be satisfied.

Dynamic similarity requires geometric and kinematic similarities between prototype and model, provided identical types of forces are parallel and have the same prototype:model ratio at all points in the corresponding flow fields.

The forces which affect a flow field are those due to inertia, pressure, viscosity, gravity, elasticity, and surface tension. The effects of the latter two forces can safely be neglected in most hydraulic models. The other

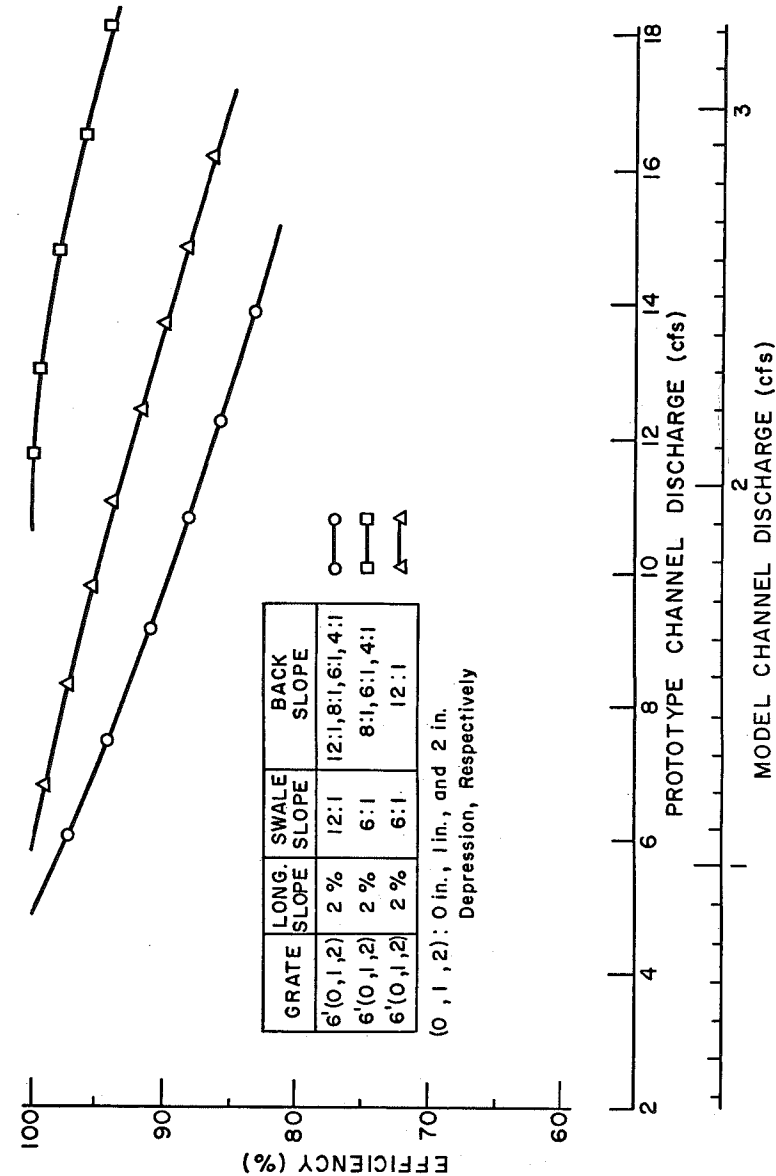

Fig. 14 Efficiency Curves for Type 6-Ft Inlet Grating (Long. Slope 2%)

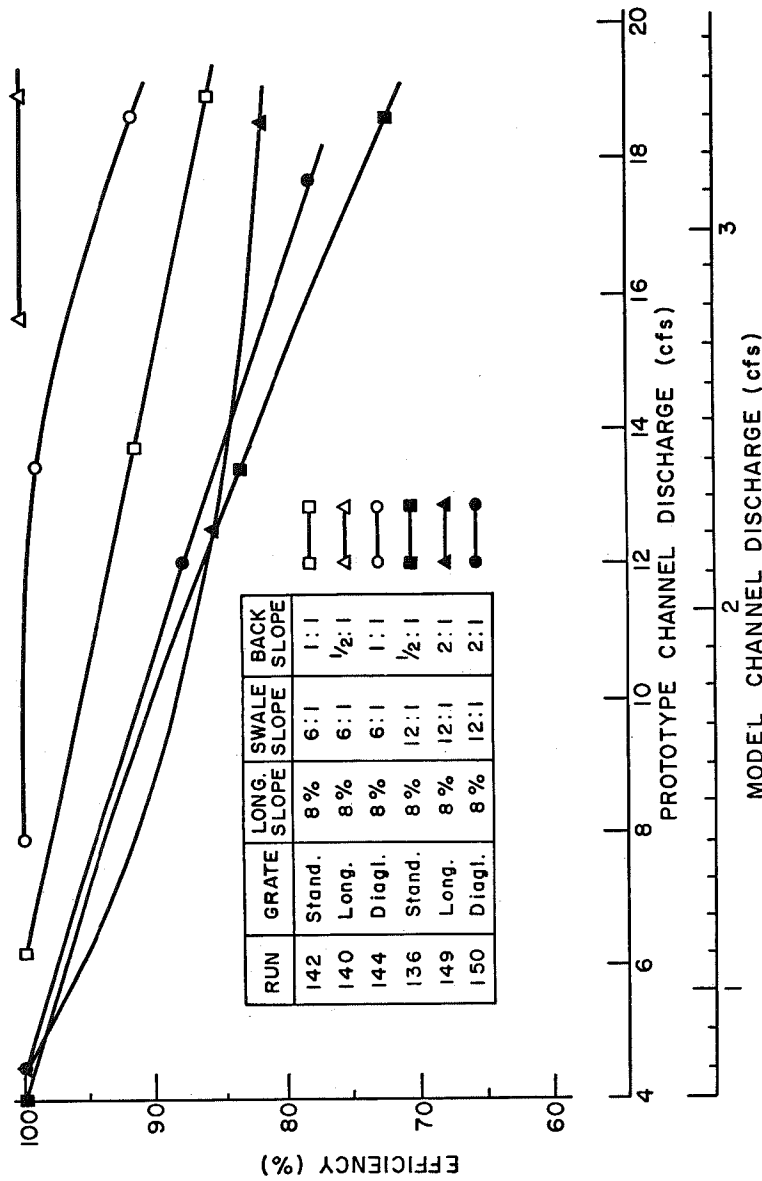

Fig. 13 Highest and Lowest Efficiencies for Type H Inlet Gratings (Long. Slope 8%)

forces are compared to the force of inertia and are customarily shown as:

Pressure: Euler number, $E = \frac{\Delta P}{\rho v^2}$ (1)

Viscosity: Reynolds number, $R = \frac{vL\rho}{\mu}$ (2)

Gravity: Froude number, $F = \frac{v}{\sqrt{gL}}$ (3)

where ΔP is a pressure difference, L is a characteristic length, ρ is the density, g is the gravitational acceleration, μ is the dynamic viscosity, and v is a flow velocity. The ratio of inertia:pressure effects was of minor importance in this study; therefore, dynamic similarity was attained by satisfying the other two equations simultaneously.

Froude Similitude

Inasmuch as flow at drainage inlets is caused primarily by gravitational forces, the only criterion that need be satisfied is that of Froude, which can be stated as:

$$\left(\frac{v}{\sqrt{gL}}\right)_p = \left(\frac{v}{\sqrt{gL}}\right)_m^* \quad (4)$$

Considering that gravity is the same in both prototype and model and that the length ratio is 2.0, the velocity ratio derived from the Froude criterion is:

$$v_r = \frac{v_p}{v_m} = 1.41 \quad (5)$$

Furthermore, the flow rate in the prototype is obtainable using the flow rate in the model and the prototype:model scale ratio. This discharge, Q , is given by the continuity equation; thus the discharge ratio, using the length and velocity ratios, becomes:

$$Q_r = 5.66 \quad (6)$$

*Subscripts p and m are for prototype and model, respectively.

Other characteristics of flow can be obtained in a similar way. All of these ratios are summarized in Table 1.

Manning Similitude

The roughness of the channel affects, not only the type of channel flow, but the efficiency of the drainage inlet as well. Hence, it is desirable to consider the forces of gravity and of friction or channel roughness. In order to do so, both the Froude and the Reynolds model laws must be considered simultaneously, but it is impossible to satisfy both laws if the same fluid is to be used in both model and prototype. Other means of correlating prototype and model must be adopted. An empirical relationship, such as the (uniform flow) Manning formula, is used as friction criterion or:

$$\left(\frac{R_h^{2/3} S^{1/2}}{v n}\right)_p = \left(\frac{R_h^{2/3} S^{1/2}}{v n}\right)_m \quad (7)$$

where R_h is the hydraulic radius, n is the coefficient of roughness, and S is the slope of the energy grade line. Because the discharge relationship is of importance, Eq. (7) can be arranged to:

$$Q_T = L_T^{8/3} / n_T \quad (8)$$

The Manning coefficient for the prototype pavement was given by the Pennsylvania Department of Transportation as 0.014, which is in good agreement with that as cited in the literature, CHOW (1959), and GRAF (1971). Exterior-grade plywood 3/4-inch thick was used in the model to simulate the paved surface of the prototype; its Manning coefficient was determined from flume tests at Lehigh University to be 0.012, which is similar to that given by CHOW (1959). Consequently, the discharge ratio for water flowing in a paved channel is shown as:

$$Q_T = 5.45 \quad (9)$$

For a natural-grassed channel the Manning coefficient of roughness is indicated as 0.035 according to CHOW (1959). An artificial grass known as "Astroturf" was used in the model to simulate natural grass; the Manning roughness coefficient of the model material was determined from flume tests

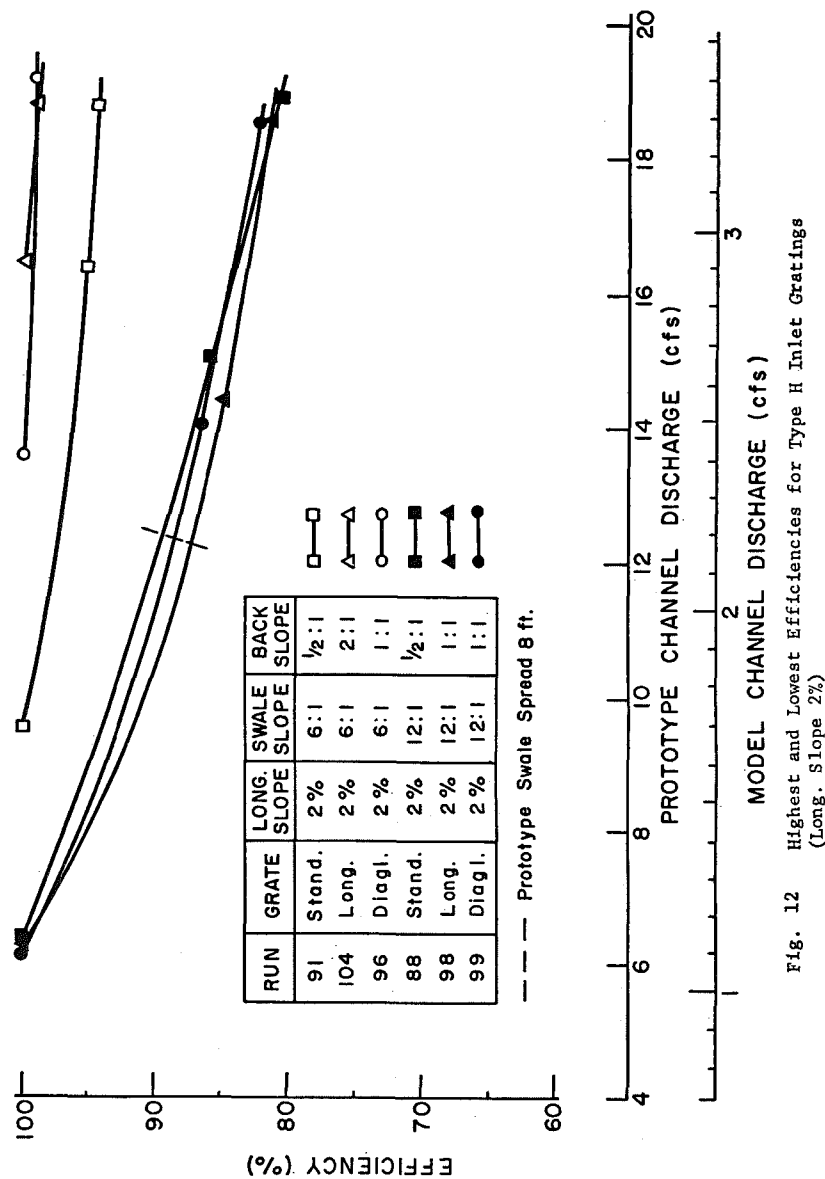

Fig. 12 Highest and Lowest Efficiencies for Type H Inlet Gratings (Long. Slope 2%)

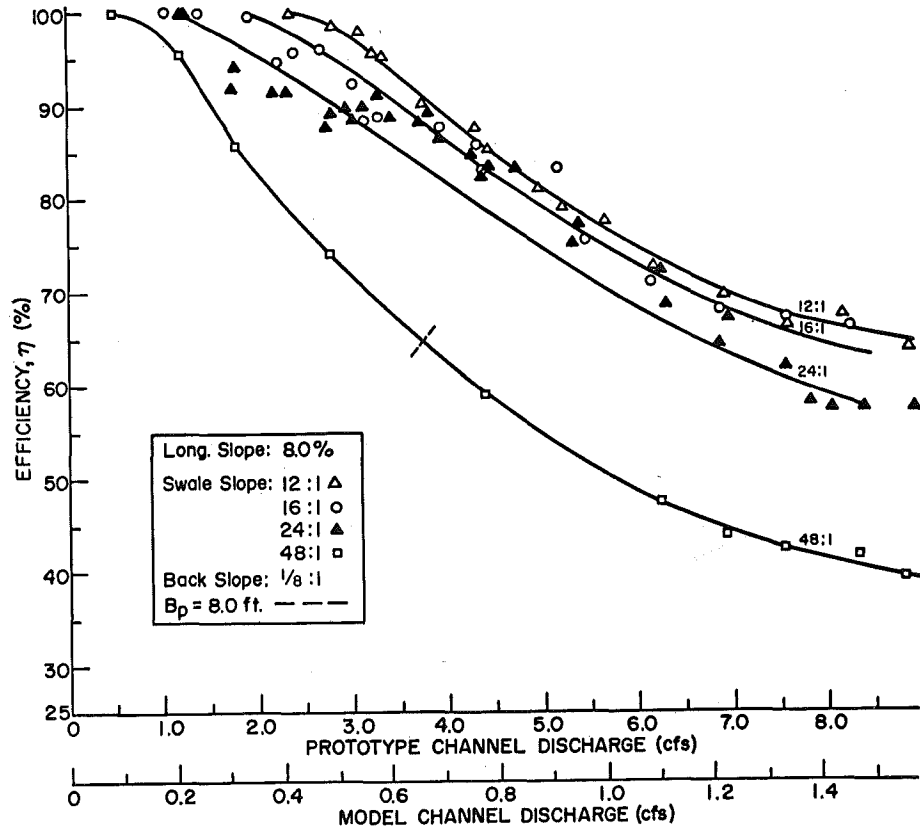

Figure 11 Efficiency Curves; Type 4-Ft Special Inlet

		Froude Similitude	Lehigh Scale	Manning Similitude	Lehigh Scale Paved Channel	Lehigh Scale Grassed Channel
Physical Properties	Length, L_r	L_r	2.0	L_r	2.0	2.0
	Area, A_r	L_r^2	4.0	L_r^2	4.0	4.0
	Volume, V_r	L_r^3	8.0	L_r^3	8.0	8.0
Kinematic Properties	Time, T_r	$L_r^{1/2}$	1.41	$L_r^{1/3}/n_r$	1.47	1.38
	Velocity, v_r	$L_r^{1/2}$	1.41	$L_r^{2/3}/n_r$	1.36	1.27
	Discharge, Q_r	$L_r^{5/2}$	5.66	$L_r^{8/3}/n_r$	5.44	5.08

$$n_r = \frac{0.014}{0.012}$$

$$n_r = \frac{0.035}{0.028}$$

Table 1 Model Scales for Froude and Manning Similitudes

at Lehigh University to be 0.028. The actual roughness ratio ($n_p/n_m = 1.125$) is found to be in very good agreement with the theoretical ratio (1.122), as obtained by inserting the length ratio from the Froude number into the Manning relation in Eq. (7).

The application of the Manning formula requires that turbulent flow be present in both model and prototype. Almost all open-channel flow found in nature is turbulent; a test of flow in this model indicated turbulent conditions prevailed.

From observation of Table 1, the adoption of either the Froude (gravity) similitude or Manning (roughness) similitude was a matter of choice. Gravity forces are more important, so Froude similitude was selected for evaluating the results of this model.

APPARATUS AND MODEL CONSTRUCTION

A schematic diagram of the testing arrangement is shown in Figure 1. The rate of inflow was measured by means of a 4-inch orifice (H) placed in a 12-inch pipe, the rating equation whereof being:

$$Q = 0.42 H^{0.5}$$

where Q is the flow rate of water (cfs), H is the difference in pressure head across the orifice (feet of water).

The testing tank, rectangular in shape, is 33 feet long overall, 16 feet wide, and 3 feet deep. The head tank containing the manifold discharge pipe is 2 1/2 feet long, 16 feet wide, and 4 feet deep. A conveyance channel, 1 foot deep with an average width of 2 feet, carries the water intercepted by the drainage inlet to an opening (T) connected to a volumetric tank. Another opening (U) near the downstream end of the testing tank is connected to the main sump. A gate diverts the water either to the volumetric tank or to the sump after it passes through or over an inlet.

Two steel frames were constructed to support the swale and back slopes, which form a triangular channel. Both frames are covered with panels of

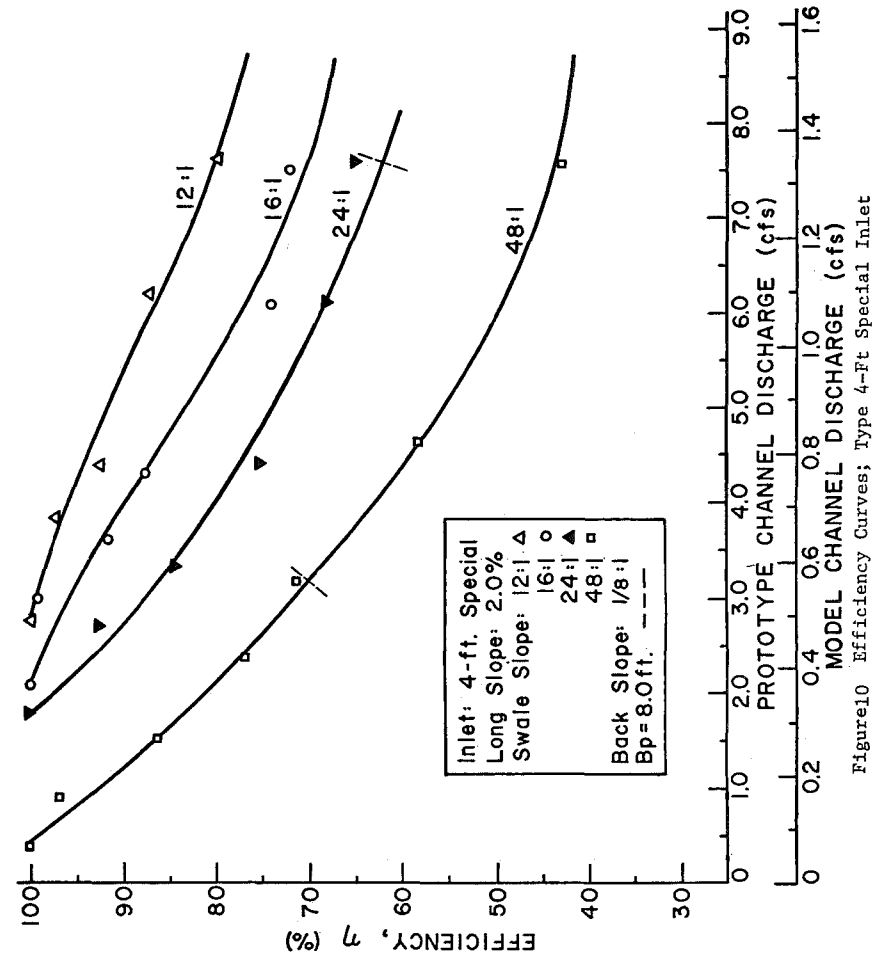

Figure 10 Efficiency Curves; Type 4-Ft Special Inlet

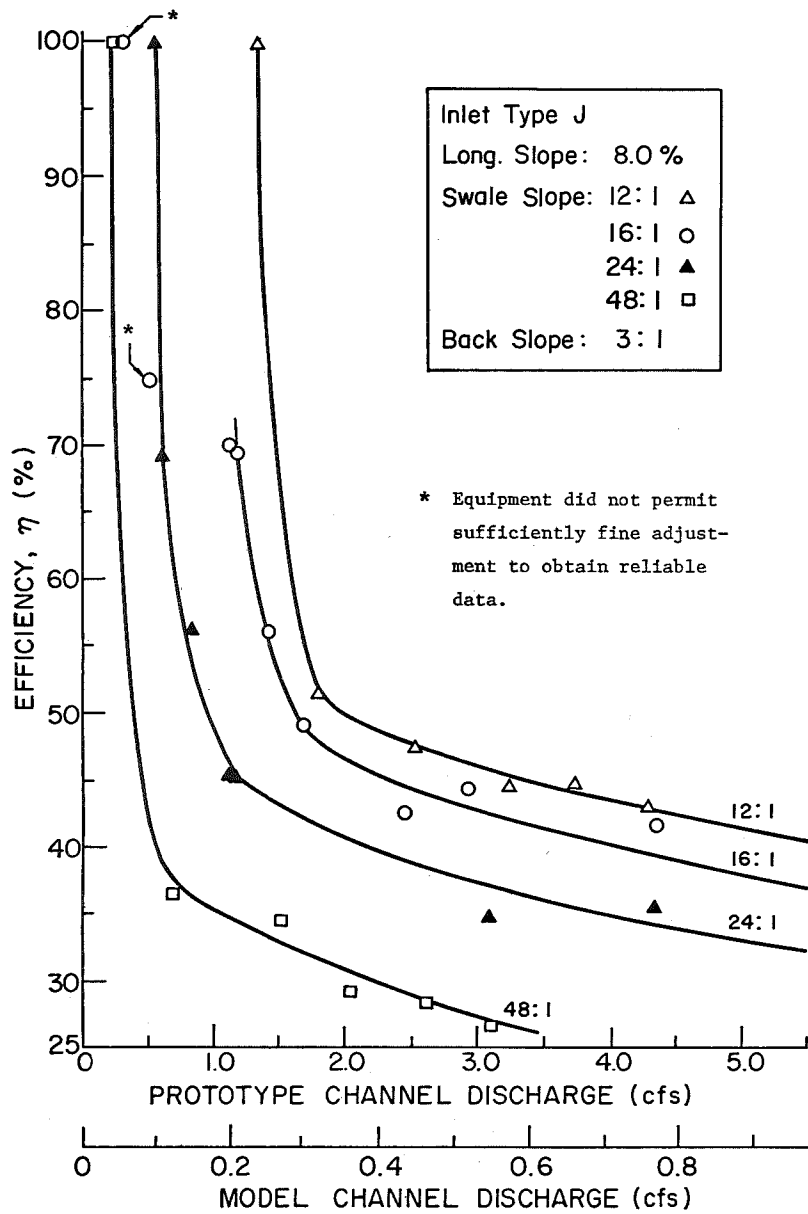

Fig. 9 Efficiency Curves; Type J Inlet (Long. Slope = 8%)
 22

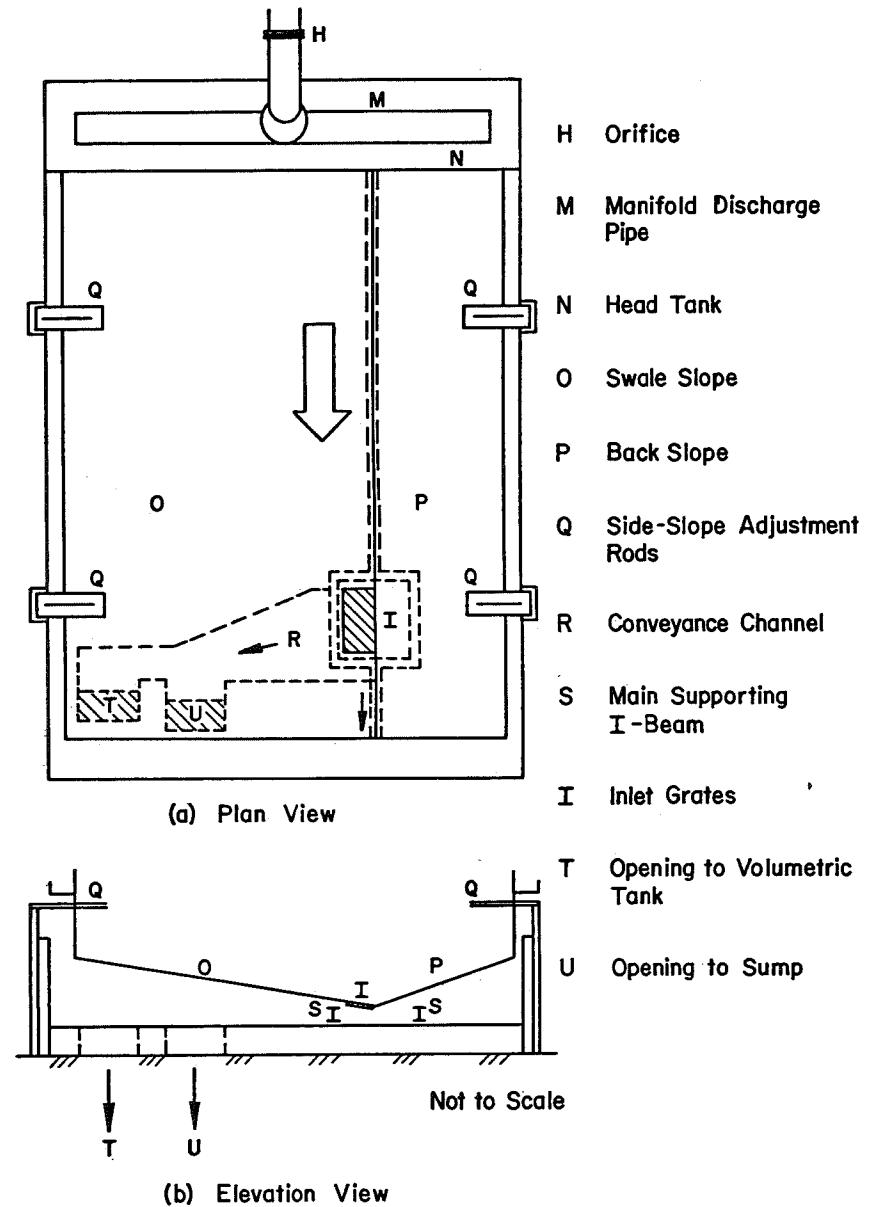

Figure 1 Testing Apparatus

plywood that are taped at the joints and painted. Hinges welded to the invert of the channel permit the slopes to rotate about the invert.

The invert rests on a W8 x 40 I-beam, which is 28 feet long; it is hinged at its downstream end. The outer edge of each frame is supported by two threaded rods for adjusting each side slope.

Hardware cloth with 1/4-inch openings was placed at the upstream end of the channel so as to aid in developing uniform flow as the water approached the inlet.

TESTING PROCEDURE

Prior to a test, the particular inlet grating was installed according to specifications; the grade was adjusted and checked with the use of a surveyor's level, and each side slope was established by using a carpenter's level.

After adjusting the flow rate, one or two minutes elapsed so as to obtain a steady-state flow in the channel. Subsequently, depth and spread measurements were made. The amount of water intercepted by the inlet was directed by the splitter into the volumetric tank for determination of the interception, Q_2 . The carryover flow rate, Q_3 , was obtained by difference.

A point gage graduated to 0.001 ft was used for all depth measurements. The gage was mounted on a small carriage rolling along a rectangular channel which was above and at right angles to the invert of the channel. Both ends of the aluminum channel were supported by a rail at each end of the beam which permitted it to travel parallel to and above the invert of the channel. Such an arrangement enabled a depth measurement to be made at any point in the channel; the measurements of depth were made at stations that were 1 foot, 2 feet, and 3 feet upstream from the inlet grating. Additionally, measurements of the spread of water on both side slopes were made at the same stations. Usually three or four rates of flow were sufficient to define an efficiency curve.

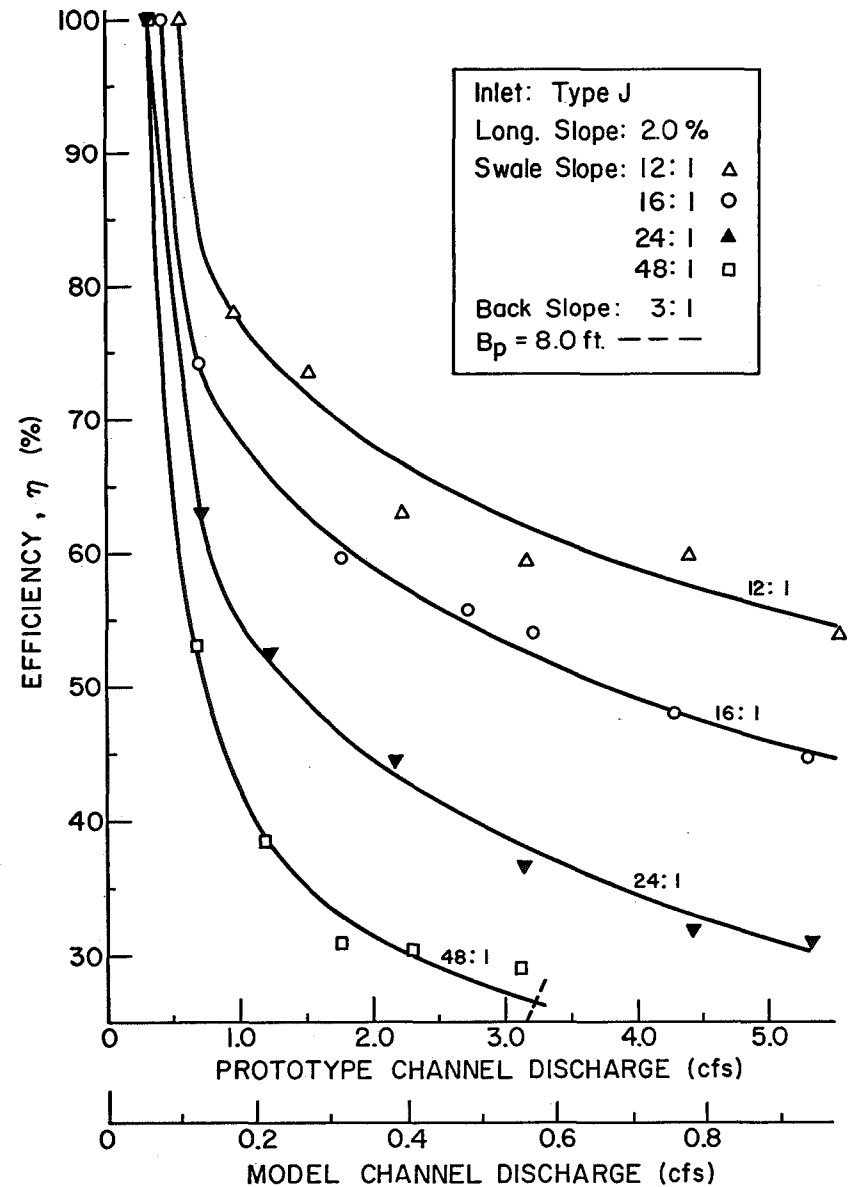

Fig. 8 Efficiency Curves; Type J Inlet (Long Slope = 2%)

lowest. The highest capacity for a swale slope of 6:1 is that of the Type 6-Ft grating for a swale slope of 6:1; whereas for a swale slope of 12:1, the highest is that of the Type H grating.

Table 5 compares the capacities of three different gratings for the Type H Inlet using the geometry of slopes as above indicated. That table shows that the difference between the capacities of the three units is of no real significance, that is, either of the three could be used with equally satisfactory results.

The efficiency curves obtained for gratings installed in grassed channels show that increasing the swale slope from 12:1 to 6:1 increases the efficiency 10% owing to the width of flow being reduced, thus causing more water to enter the inlet. The efficiency of a grating tends to decrease as the grade of the channel increases. On grades above 2% some of the water in the channel tends to flow along the tops of the bars of the grating, thus overflowing the inlet and not dropping through the grating.

Figure 12 shows the efficiency curves for the Type H inlet gratings having the three geometries of rectangular bars (the standard) as well as the longitudinal and diagonal bars installed on a grade of 2%. The swale slope of 6:1 has a greater capacity than the slope of 12:1 which has a width of flow greater than the steeper slope. The prototype spread of 8 ft occurred only on the flat swale slope.

Figure 13 is an identical plot with the difference being the steeper grade of 8%. The efficiencies shown in this figure are somewhat less than those shown in Figure 12, although the two plots are quite similar.

The efficiency curves for a Type 6-Ft inlet installed in grassed channels having a grade of 2% and 8% are shown in Figures 14 and 15, respectively. Again the point is apparent that a steep swale slope of 6:1 has a greater capacity at any one efficiency than a swale slope of 12:1. Tests were conducted with the top of the grating being depressed zero, 1 inch, and 2 inches

Table 2 indicates the combinations of channel configurations that were used to accomplish the tests involved in this study.

Table 2 Summary of Channel Configurations

Inlet	Swale Slope	Back Slope	Longitudinal Slope
Type J	12:1, 16:1 24:1, 48:1	3:1	0.5%, 2%, 4%, 8%
Type 4-Ft Special	12:1, 16:1 24:1, 48:1	1/8:1	0.5%, 2%, 4%, 8%
Type 6-Ft Special	12:1, 16:1 24:1, 48:1	1/8:1	0.5%, 2%, 4%, 8%
Type H	6:1, 12:1	½:1, 1:1 2:1, 4:1	0.5%, 2%, 4%, 8%
Type 4-Ft	6:1, 12:1	4:1, 6:1 8:1, 12:1	0.5%, 2%, 4%, 8%
Type 6-Ft	6:1, 12:1	4:1, 6:1 8:1, 12:1	0.5%, 2%, 4%, 8%

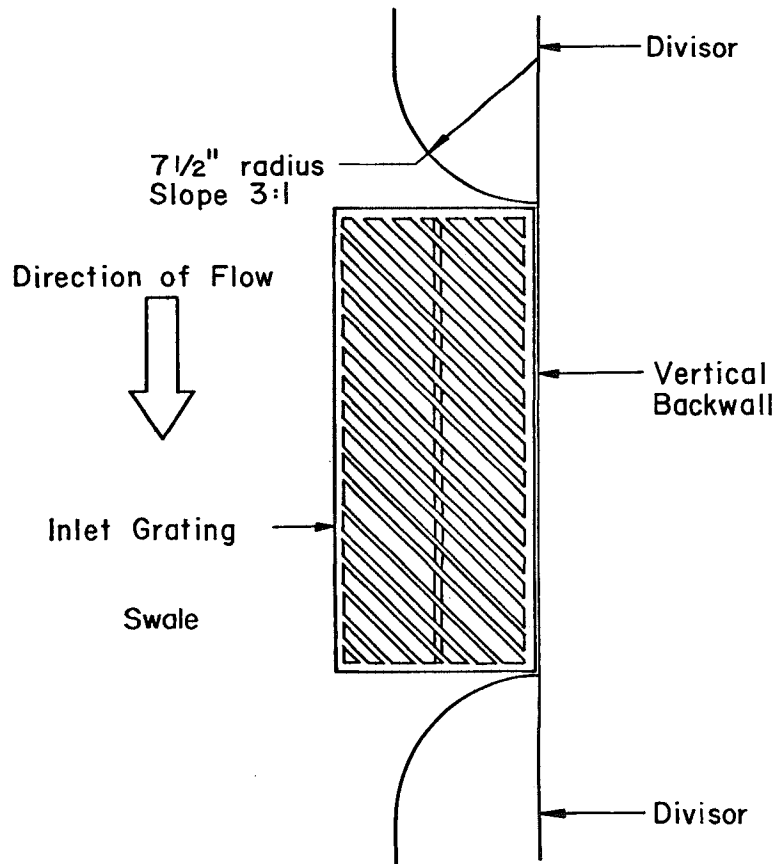

(a) Plan View

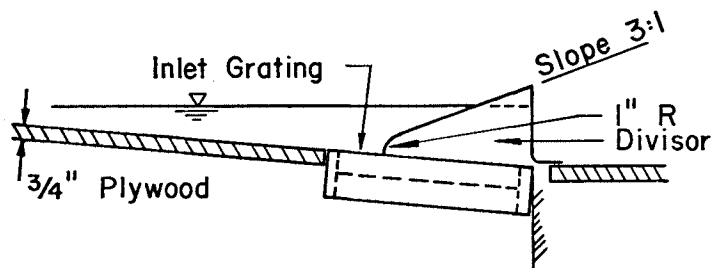

(b) Elevation View

Figure 2 Installation, Type J Model Grating

accuracy of the spread measurements was 0.01 foot. Three spread readings on either slope were taken for each flow rate at the stations where the depths were measured.

Efficiencies of Inlets

The main purpose of this study was to determine experimentally through the use of half-scale models the efficiencies of several different types of inlet gratings used by PennDOT under the channel configurations as indicated in Table 1. Inasmuch as the inlet gratings are not identical in construction and installation, the efficiencies will differ from one type to another when tested under the same conditions.

The Type J Inlet grating is installed at the left edge of the passing lane, particularly on a highway which curves toward the left. Figure 8 shows the efficiency curves of Type J Inlet for one set of slopes. Curves for that inlet installed on steeper slopes are similar except that they are crowded toward the vertical axis. For a constant channel configuration the efficiency of an inlet decreases with an increase in the channel flow rate. The high efficiencies that are present at low channel flow rates decrease almost precipitously as the flow rate increases. The efficiency curves flatten somewhat with a further increase in water flow.

A flat longitudinal slope of the channel leads to a higher efficiency of an inlet in comparison to the results from a steep slope because for the latter situation more water bypasses the inlet. In general, channels with a 1/2% longitudinal slope yield the highest efficiency for Type J Inlet.

The inlet gratings designated as Type H, Type 4-Ft, and Type 6-Ft are installed in grassed channels that are either along the side of a highway or in the median between traffic lanes. Table 4 lists the capacity of the standard gratings for those three inlets at an efficiency of 100% for four grades and for two swale slopes with the back slope being constant. The data in the table indicate that the capacity of the Type 4-Ft grating is the

corresponding to a spread of 4 feet in the model. The absence of the three dashes on a curve indicates that the limiting spread was not obtained.

The flow rate is another factor affecting the efficiency of the inlet, the efficiency decreasing with both an increase in flow rate and an increase in longitudinal slope.

The Type 4-Ft Special and the Type 6-Ft Special Inlet gratings are installed in paved channels that are at the shoulder of the highway. Fig. 10 shows the efficiency curves of the 4-Ft Special Inlet on a grade of 2%. The curves for steeper grades are higher than the positions shown in that graph. A plot of the Type 6-Ft Special Inlet is not shown because the curves are very similar to those of the Type 4-Ft Special Inlet; the grating thereof usually has a higher efficiency than the Type 4-Ft Special Inlet for the same operating condition and flow rate, although the difference is small.

Steep curves are uncommon for these two inlets in contrast to the Type J Inlet, and the efficiency curves tend toward a parallelism. The plots indicate that the channels with steep slopes are more efficient than those with flat slopes, the steep slopes having a marked decrease of efficiency with an increase in flow rate in comparison to the more gentle decrease in efficiency for the flatter swales.

The efficiency of either inlet was greater, if placed on either a 2% or 4% grade, than if placed on a 1/2% or 8% grade. On a swale slope of 48:1 the efficiency of both Special Inlets was almost the same on all longitudinal slopes, regardless of whether the inlet was 4 feet long or 6 feet long. Considering all the results obtained, the Type 6-Ft Special Inlet has a slightly higher efficiency than the Type 4-Ft Special, although the difference is not that marked as to be significant.

For slopes flatter than 4:1 the accuracy of the spread measurements was 0.1 foot, owing to fluctuations in the spread and to poor definition of the water edge on the artificial turf. For slopes steeper or equal to 4:1 the

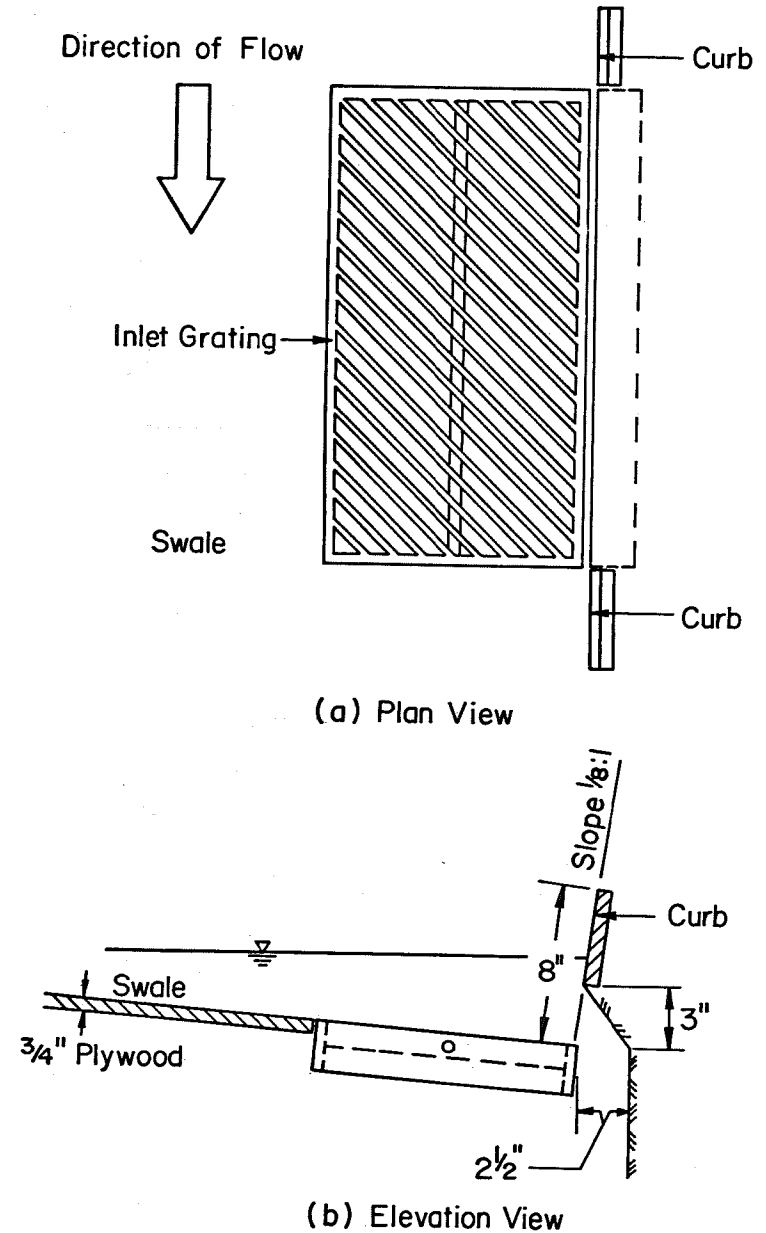

Figure 3 Installation, Type 4-Ft Special Model Grating

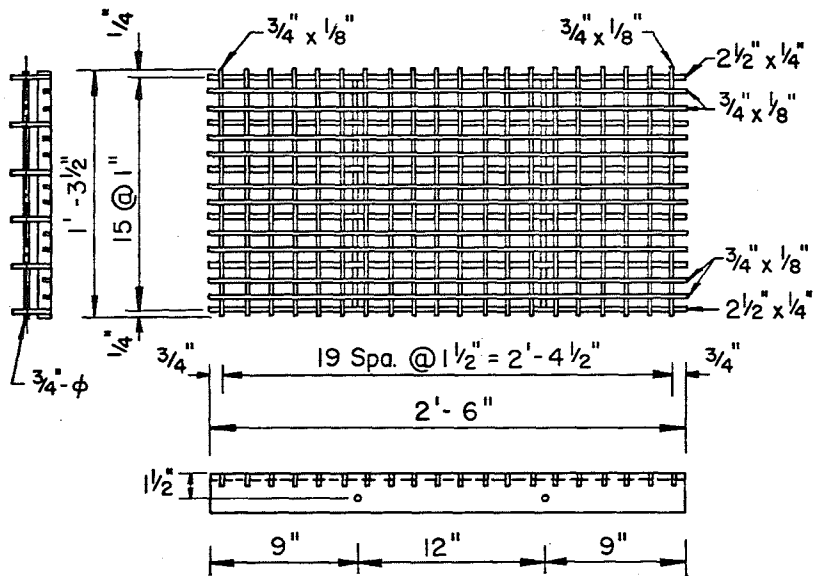

Figure 4 Model Grating for Type H Standard Inlet

RESULTS

Summaries of the results of the tests are shown in Tables 3, 4, and 5 which list the prototype capacity of each inlet at an efficiency of 100% for the grades and slopes indicated. The capacity of a grating at 100% efficiency refers to the fact that no water overflows or bypasses the grating, rather that all of the water approaching it is intercepted by the grating.

The total number of tests that were run in order to examine the capacity of the inlets for the variables of the side and swale slopes, the longitudinal grades, and the inlet gratings themselves was 600. Detailed results of each test are shown in YEE and others (1972) and in APPEL and others (1973).

Representative graphs which relate efficiency to the rate of flow approaching the inlet are shown in Figures 8 to 16. Most of the graphs are for the grade of either 2% or 8% as being fairly indicative of the results. The references cited contain detailed graphical presentations of all the grades used in the tests.

TABLE 5
COMPARISON OF CAPACITIES OF TYPE H INLET GRATINGS

Capacity, in cubic feet per second				
Long. Slope (1)	Swale Slope (2)	Rectangular (3)	Longitudinal (4)	Diagonal (5)
0.5%	12:1	7.70	6.34	6.62
2%	12:1	7.47	7.19	7.98
4%	12:1	7.13	7.64	7.13
8%	12:1	5.83	5.83	5.55
0.5%	6:1	10.13	8.94	8.89
2%	6:1	8.72	9.17	8.04
4%	6:1	7.07	7.24	7.64
8%	6:1	5.26	5.60	5.32

NOTE: The back slope is 4:1

Rectangular: The standard grating

Longitudinal: A grating with bars parallel to the flow

Diagonal: A grating with bars at 45° to the flow

The efficiency is 100%; that is, no water overflows the grating.

DISCUSSION

The efficiency of an inlet grating, indicated as η , is defined as $(Q_2/Q_1) \times 100\%$, where Q_1 is the channel flow rate and Q_2 is the rate of flow intercepted by the inlet grating. The efficiency is a significant variable which illustrates the hydraulic performance of a drainage inlet grating. The prototype channel flow rate, Q_1 , is plotted on the lower horizontal axis against the efficiency on the vertical axis. The model channel flow rates ranged from 0.04 to 1.65 cfs for inlets installed in paved channels and from 0.42 to 3.40 cfs for those in grassed channels.

In order to compare the efficiency of different inlets or the effect of different channel configurations, a family of efficiency curves is shown in each figure. The three dashes on a curve show the flow rate at which a water spread of 8 feet was exceeded on the swale in the prototype channel,

TABLE 3

CAPACITY OF GRATINGS INSTALLED IN PAVED CHANNELS

Long. Slope (1)	Swale Slope (2)	Capacity, in cubic feet per second		
		Type J (3)	Type 4-Ft Special (4)	Type 6-Ft Special (5)
0.5%	12:1	0.68	1.47	2.66
2%	12:1	0.57	2.77	4.02
4%	12:1	0.48	3.40	4.08
8%	12:1	1.34	2.41	2.74
Back Slope		3:1	1/8:1	1/8:1

NOTE: The efficiency is 100%; that is, no water overflows the grating.

TABLE 4

CAPACITY OF GRATINGS INSTALLED IN GRASSED CHANNELS

Long. Slope (1)	Swale Slope (2)	Capacity, in cubic feet per second		
		Type H (3)	Type 4-Ft (4)	Type 6-Ft (5)
0.5%	12:1	7.70	3.56	4.07
2%	12:1	7.47	3.45	4.19
4%	12:1	7.13	1.98	3.18
8%	12:1	5.83	1.98	1.98
0.5%	6:1	10.13	8.37	12.45
2%	6:1	8.72	7.70	11.30
4%	6:1	7.07	7.98	10.27
8%	6:1	5.26	6.22	8.09

NOTE: The back slope is 4:1

The efficiency is 100%; that is no water overflows the grating

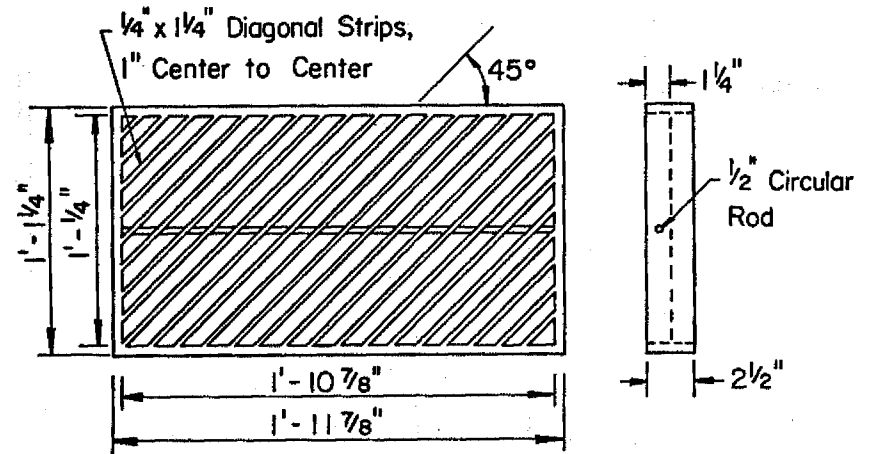

(a) Type 4-ft. Inlet

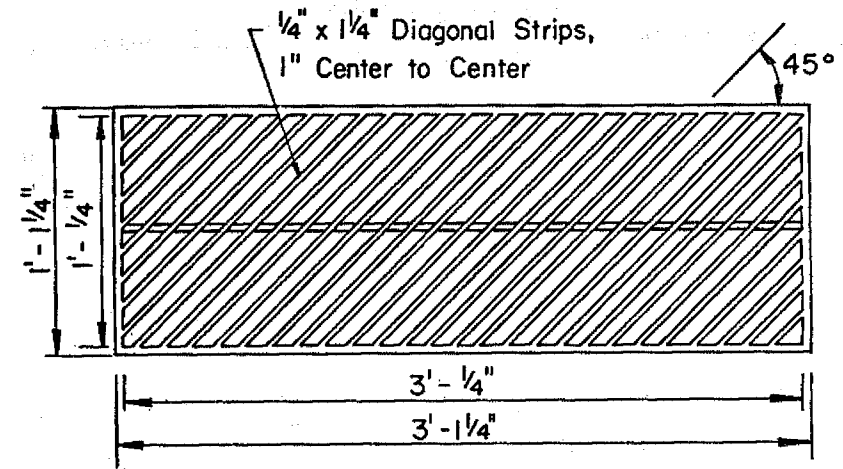

(b) Type 6-ft. Inlet

Fig. 5 Gratings for Model Type 4-Ft Inlet and Model Type 6-Ft Inlet

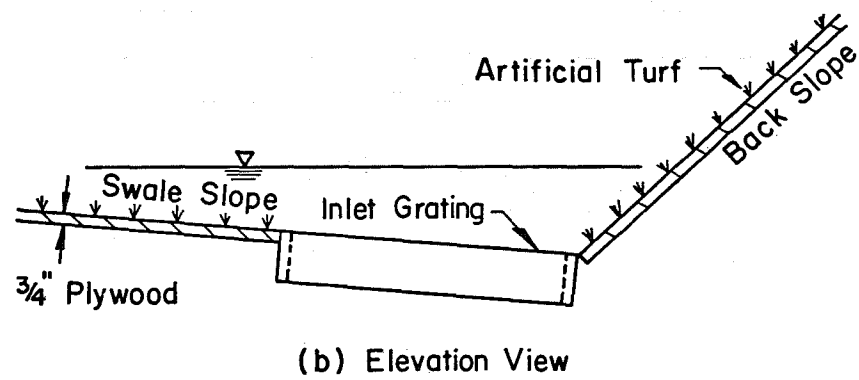
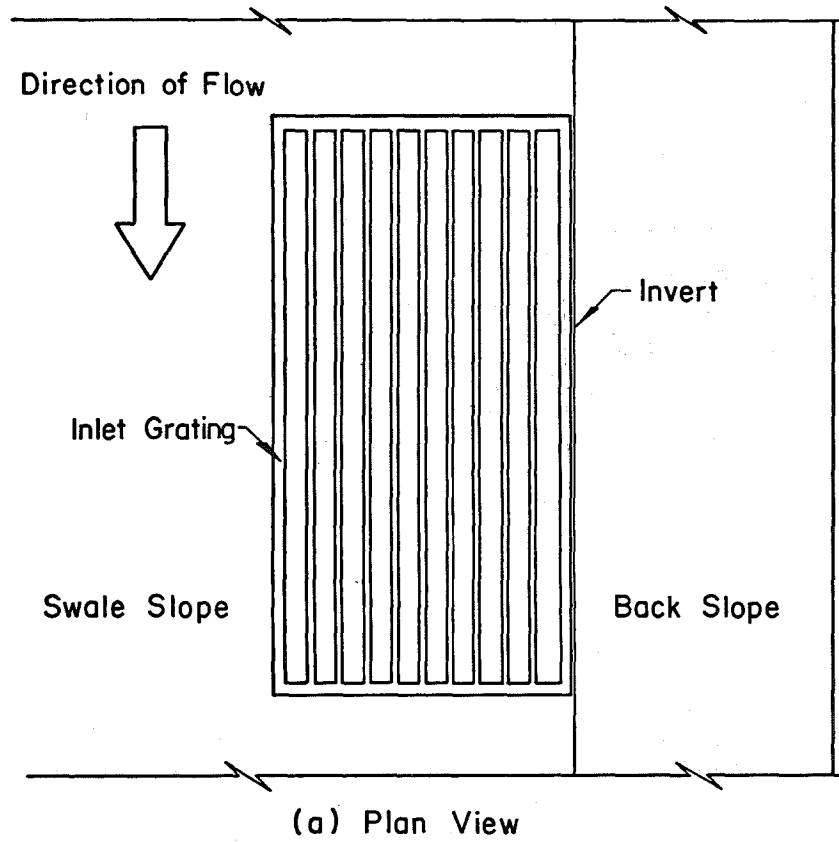

Fig. 6 Installation of Gratings for Type H Inlet

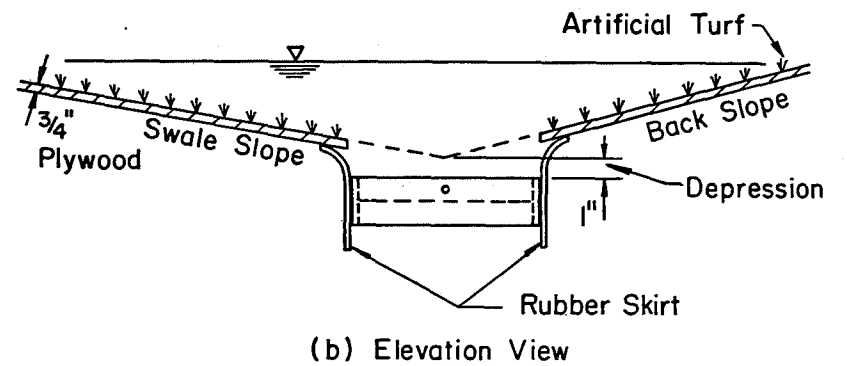
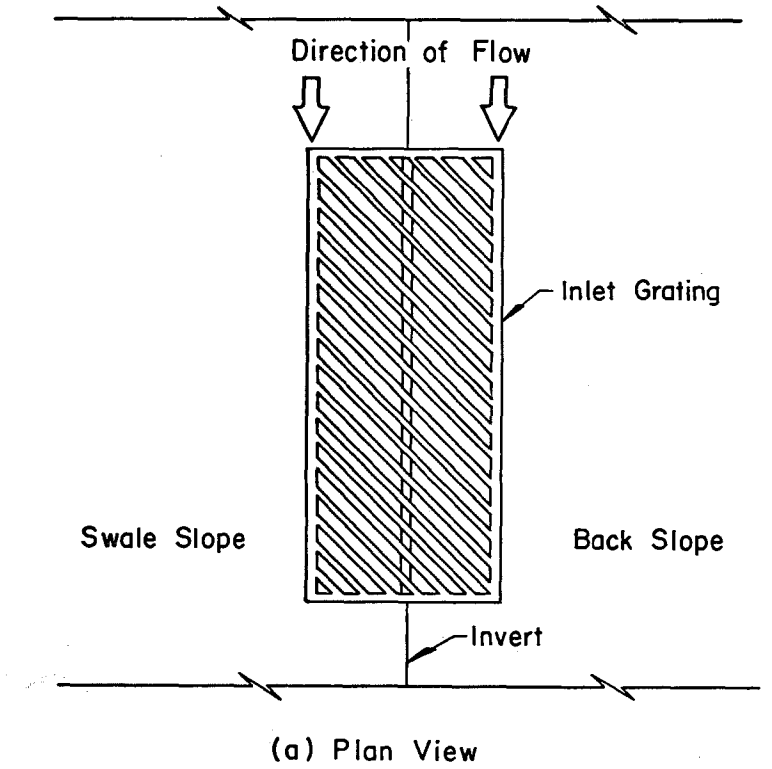

Figure 7 Installation, Type 4-Ft or 6-Ft Model Grating