

1969

Residual stresses in heavy welded shapes, January 1969 (70-6)

G. Alpsten

L. Tall

Follow this and additional works at: <http://preserve.lehigh.edu/engr-civil-environmental-fritz-lab-reports>

Recommended Citation

Alpsten, G. and Tall, L., "Residual stresses in heavy welded shapes, January 1969 (70-6)" (1969). *Fritz Laboratory Reports*. Paper 334. <http://preserve.lehigh.edu/engr-civil-environmental-fritz-lab-reports/334>

This Technical Report is brought to you for free and open access by the Civil and Environmental Engineering at Lehigh Preserve. It has been accepted for inclusion in Fritz Laboratory Reports by an authorized administrator of Lehigh Preserve. For more information, please contact preserve@lehigh.edu.

G.C. Dierckx



Residual Stresses in Thick Welded Plates

RESIDUAL STRESSES IN HEAVY WELDED SHAPES

by
Goran A. Alpsten
Lambert Tall

January, 1969

Fritz Engineering Laboratory Report No. 337.12

ICORP
RESEARCH
INSTITUTE
FOR
STRUCTURAL
ANALYSIS
AND
DESIGN

Residual Stresses in Thick Welded Plates

RESIDUAL STRESSES IN HEAVY WELDED SHAPES

by

Goran A. Alpsten and Lambert Tall

Fritz Engineering Laboratory
Department of Civil Engineering
Lehigh University
Bethlehem, Pennsylvania

January, 1969

Fritz Laboratory Report No. 337.12

337.12

TABLE OF CONTENTS

	<u>Page</u>
ABSTRACT	1
INTRODUCTION	4
FABRICATION OF TEST SPECIMENS	8
PROCEDURE FOR MEASUREMENT OF RESIDUAL STRESS	10
TEST RESULTS	14
DISCUSSION OF RESULTS	19
CONCLUSIONS	28
ACKNOWLEDGMENTS	33
TABLES AND FIGURES	35
REFERENCES	62

ABSTRACT

Residual stresses can have a significant influence on the load-carrying behavior of structural steel members subjected to compressive loads. Previous experimental research on residual stresses and the strength of columns was related to small and medium-size shapes. In today's large structures, increasingly heavy shapes are employed. While heavy column shapes are being used extensively, very little information has been available on the residual stresses and strength of such members.

This paper presents the results of the first phase of a major investigation into the residual stresses in, and the behavior of, thick plates and heavy shapes used in compression members. The shapes considered in this initial study are a 15H290 shape and a 23H681 shape, as well as two loose component plates, PL16x2 and PL24x3 $\frac{1}{2}$. For the smaller shape, comparative tests were carried out for different manufacturing conditions of the component plates (universal-mill and flame-cut plates), different weld type (penetration) and different yield strengths of the material.

The results of residual stress measurements carried out in this first phase of the study indicate that, for heavy fabricated members,

- all phases of the manufacture and fabrication procedure generally affect the formation of residual stresses,
- the weld type (penetration) and the yield strength of the steel are not major factors in the formation of residual stresses,
- the geometry of the plates and shapes is one of the important variables affecting the residual stress magnitude and distribution,
- the variation of residual stress across the thickness of plates more than one inch thick can be considerable,
- the welding residual stresses in portions of the cross section other than the weld area tend to decrease with increasing size of the member, probably because the weld area, and consequently, the heat input, is relatively smaller in heavy plates and shapes as compared to light members,
- the initial stresses can be of a higher magnitude than the welding residual stresses.

The relationship between initial residual stresses in component plates and welding residual stresses implies that efforts to limit the magnitude of residual stresses in heavy

welded shapes should be directed towards the manufacture of the component plates. Thus, by using flame-cut plates in heavy welded shapes, there is a prospect for an increase in strength when compared with lighter members at the same slenderness ratio. There is even a possibility that such welded shapes may be stronger than their rolled counterparts.

INTRODUCTION

Only in the past two decades was it experimentally and theoretically verified that residual stresses are a major influence on the strength of steel members in compression. It was shown that they have a significant effect on column strength^(1,2) and on the buckling of plates.^(3,4) It is also known that residual stresses can be of great importance in fatigue, brittle fracture, and stress corrosion.

The previous experimental research on residual stress and the strength of welded steel members was related to small and medium-size shapes, that is, shapes of components with a thickness equal to or less than one inch.^(5,6,7) In today's large structures, increasingly heavy shapes are used. Very little information has been available on the residual stresses and strength of heavy columns, yet they are used extensively in North America and elsewhere. Applications include the lower stories of multi-story buildings, major bridges, and launching gantries for rockets and space vehicles. Similar structural elements are used in ship and submarine hulls, and in vessels for atomic reactors.

Some heavy column shapes used in existing structures are shown in Fig. 1, which also illustrates the different ways

of designing a heavy column shape. Rolled shapes can be used and are available in sizes up to the 14WF730 "jumbo" shape of Fig. 1a. If the strength of the available rolled shape is insufficient for a particular application, plates can be welded to a rolled shape as shown in Figs. 1b and c. A heavy shape can also be built up from welding together three plates to form an H-shape, as illustrated in Fig. 1d. Finally, a box-shape can be made from welding together four plates, Fig. 1e. The plates used in a welded shape can be manufactured either as universal-mill plates, that is, rolled to exact width and used with as-rolled edges, or as flame-cut plates, that is, flame-cut from a larger parent plate.

At present, the design of heavy columns does not differ from that of small and medium-size columns. The design criteria previously developed for small and medium-size rolled columns⁽²⁾ have been extrapolated to include heavy members. While experience has indicated that this leads to safe design, it may not be a completely rational design method.

An extensive research program is currently underway at Lehigh University to study residual stresses in heavy welded plates and shapes. (Heavy plates and shapes are defined here as members with a thickness exceeding one inch). The specific objectives of the study are to determine the magnitude and distribution of residual stresses in thick welded

plates by both experimental and theoretical means, and to relate this to the stability under compressive loads of structural members.

Prior to the initiation of the current study, critical information was lacking on the behavior of heavy columns. The present status is illustrated in Fig. 2 which shows (a) the largest test shape so far used in a multi-story frame test, (b) the largest welded shape in a beam-column test, (c) the largest column shape, and (d) the largest stub column shape. The shapes in Figs. 2e through g are examples of the specimens in the current research program. These shapes compare to the heavy column shapes used in construction (see Fig. 1).

The paper presents some experimental results obtained in the first phase of the investigation. While the specimens in the overall program cover the complete range of dimensions which are practical in construction, that is, plates ranging in size from $9 \times \frac{1}{2}$ up to 24×6 and welded H-shapes and a Box-shape ranging from a 7H28 to a 24H1122 shape, the specimens considered in this paper are the 15H290 and 23H681 shapes (see Figs. 2d and e) as well as two as-manufactured plates, 16×2 and $24 \times 3\frac{1}{2}$. Figure 3 shows a comparison between the 23H681 shape and the 7H28 shape, corresponding to the heaviest and lightest welded specimens

tested so far in the Lehigh program.

The results of the overall study will allow the prediction of residual stresses in any plate and any welded shape used in construction. The plates and shapes in the investigation will serve as reference data, and by knowing the dimensions of components and the manufacturing and fabrication details of a practical column, the distribution of residual stress can be predicted. The column strength can then be determined, including the effect of residual stresses.

The study is of a fundamental nature and of considerable importance in many areas; however, the present application is the development of information which will be useful in preparing design criteria for heavy column members as are used in construction. The findings obtained for the basic welded plates will be applicable also to other types of structures, for instance, ship and submarine hulls, and atomic reactor vessels.

FABRICATION OF TEST SPECIMENS

The test specimens were fabricated by steel fabricators according to normal practices and procedures. The AWS Specifications were followed in the fabrication. The submerged arc welding method was used for all specimens. Pertinent welding data have been summarized in Table 1.

The first four specimens were fabricated from universal-mill plates, that is, the component plates in the welded shapes were used with as-rolled edges. The remaining specimens were fabricated from flame-cut plates, obtained by flame-cutting the component plates from larger parent plates. Specimens of the 15H290 shape were fabricated in both ASTM A36 and A441 steel for comparative tests. In addition, both a fillet weld (partial penetration) and a groove weld (full penetration) were used. For the heavy shape 23H681 only one specimen of A36 steel with fillet welds was fabricated.

The welds in the 15H290 shapes were deposited in a symmetrical pattern as indicated in Table 1, to minimize the distortion of the members. Two passes were used for the 15H290 shapes with fillet welds, but seven passes were required for the groove welds.

The 23H681 shape was welded using an automatic beam welding machine with two tandem electrodes. Thus, it was

possible to weld simultaneously on both the left and the right side of the shape, each weld being deposited in one pass from one DC electrode and one AC electrode spaced $4\frac{1}{2}$ inches apart. After the first flange and the web were joined together, the T-shape was turned over and the second flange was welded to the T to form the final H-shape. Figure 4 shows the 23H681 specimen and the beam welding machine used for the fabrication. A more detailed account of the fabrication of the 23H681 shape can be found in Ref. 8.

It was specified that no straightening operations in any form should be used after the welding. In practice, such operations may become necessary to fulfill straightness requirements. The common methods used for straightening heavy welded shapes, that is, gaging or local heating by a flame, will change the residual stress distribution locally at the straightened section. The residual stresses in the unstraightened parts of the column will remain unchanged.

PROCEDURE FOR MEASUREMENT OF RESIDUAL STRESS

The residual stress distribution in a thick plate is generally three-dimensional with stresses in the longitudinal as well as the transverse directions. While the transverse stresses will affect the yielding behavior of the different fibers of the cross section, the longitudinal stresses are of primary interest for column strength. Thus, the theoretical methods normally employed for the prediction of column behavior and maximum strength of columns consider the longitudinal residual stresses only.

When only longitudinal stresses are taken into account in the theories for column strength prediction, it is in fact more relevant in the residual stress measurement to consider the apparent longitudinal stresses as obtained directly from the measured released strain in the longitudinal direction, rather than to separate the influence of the stresses in all three directions.⁽⁹⁾ This is because the effect of transverse stresses on the measured released strain in a sectioning procedure is somewhat similar to that on the yielding behavior of a column under load. Thus, there are two approximations, the error of which tend to cancel each other.⁽⁹⁾ With this procedure of treating the measurements as one-dimensional, and when the transverse stresses are

reasonably small, that is, less than 50% of the longitudinal stress, the relative error in the applied stress to cause yield in a fiber is less than 20%. For the behavior of the complete cross section, the relative error will be considerably less.

Another important feature of the residual stress distribution in thick components is that the longitudinal stresses can be expected to vary significantly through the thickness of the components. The method for measurement of residual stresses must take into account this variation.

The procedure used for the measurements was a sectioning method, involving longitudinal saw cuts both across the width and through the thickness of the components. The method is basically similar to the sectioning method used by Kalakoutsky in 1888 for the measurement of residual stresses in steel cylinders.⁽¹⁰⁾ The technique of the sectioning method as applied to heavy welded shapes was developed in the Lehigh research program.⁽¹¹⁾

Gage points were first laid out around the specimen (see Fig. 5), and readings were obtained using a ten inch Whittemore mechanical extensometer. The specimen was then cut into elements containing one or more gage points on each surface ("sectioning") and new measurements were made. The released strains at both surfaces of the

elements could be evaluated from these measurements. If the ratio of width to length and width to thickness of the elements is such that beam-type action will occur, the through-thickness variation of strains released in the sectioning ($\epsilon_{\text{sect.}}$) will approximate a straight line going through the data points obtained on the surfaces. Measurements have indicated that the straight-line assumption is reasonable for the geometry of elements used, and this assumption is the basis for the evaluation procedure.

The sectioning was then continued to obtain the actual variation of residual stress through thickness. After the first set of saw cuts were made ("sectioning"), additional gage points were laid out along the sides of the elements. New readings were taken by the extensometer, followed by sawing the elements into strips across the thickness ("slicing"). From extensometer readings before and after the slicing, additional strains, $\epsilon_{\text{slic.}}$, were obtained. These strains are superimposed upon the strains from the sectioning to furnish the total strain variation. See Fig. 5. Assuming that all residual strains have been released, the residual stress may be obtained from the relationship

$$\sigma_R = -E (\epsilon_{\text{sect.}} + \epsilon_{\text{slic.}}) \quad (1)$$

The residual stresses released in the slicing procedure must be in equilibrium for each sectional element. Thus, there is no contribution to the average stress through thickness from these stresses. Consequently, the average residual stress obtained as the mean value of readings from both surfaces in the sectioning procedure is equal to the actual average stress through the thickness.

The accuracy in the stress measurement is of the order of ± 1 ksi. An extensive study of the accuracy and the error sources in the measurements was carried out in connection with the investigation. (12)

The experimental work involved in the method is enormous, both with respect to the required number of gage point readings and the necessary sawing operations. For example, the number of gage readings involved in the measurements on a 24" x $3\frac{1}{2}$ " plate (see Figs. 17 and 19) is more than 5000; the sawing was done on a band saw and required a net machine time of the order of 100 hours.

TEST RESULTS

The residual stress distributions obtained from sectioning of the four 15H290 specimens fabricated from universal-mill plates are given in Figs. 6 through 9. The curves shown refer to the results obtained on both surfaces of the shape components in the sectioning, that is, before slicing. The shapes in Figs. 6 and 7 are of A36 steel, differing only in the type of weld. Figures 8 and 9 show a similar comparison for A441 steel.

The results of a complete sectioning and slicing procedure from one of the specimens is given in Fig. 10. The residual stress distribution is represented in the form of an iso-stress diagram, that is, contour lines for constant stress.

For all four shapes of universal-mill plates, the stresses at the flange tips are in compression, and of a relatively high magnitude. The average stress at the flange tip varies between -16 ksi and -24 ksi for the four shapes.

Figures 11 through 14 show the residual stresses as measured in the four 15H290 specimens fabricated from flame-cut plates. Again, the curves in the diagrams correspond to the measurements obtained on both surfaces of the components

in the sectioning test. Each specimen made of flame-cut plates in Figs. 11 through 14 corresponds to a similar specimen made of universal-mill plates, Figs. 6 through 9, so the distributions may be compared directly. Instead of relatively high compressive stresses, as in the universal-mill plates, there are very high tensile stresses at the flange tips of the shapes made of flame-cut plates.

Figure 15 gives the results obtained from sectioning and slicing of the 15H290 specimen made of A36 steel, and with fillet welds. As may be seen from the contour lines, there are steep stress gradients in the weld region and at the flame-cut edges.

As will be discussed further in the next section, it is obvious from the results on the 15H290 specimens that the initial stresses existing in the component plates prior to welding are of great importance. Therefore, measurements on the component plates, before welding, were included in the study of the 23H681 shape. Figures 16 and 17 give the average residual stress through the thickness for a 16" x 2" plate, taken from the same parent plate as the web plate of the shape, and a 24" x 3 $\frac{1}{2}$ " plate, corresponding to the flange plates of the shape. The stresses at the plate edges are in tension with a maximum of approximately 50 ksi at the flame-cut surface. The tensile stresses are balanced

by compressive stresses in the center of the plates.

A complete picture of the actual distribution of longitudinal residual stresses in the thick plates can be obtained only from a study of the two-dimensional variation of residual stresses over the cross section. Figures 18 and 19 show iso-stress diagrams as obtained from sectioning and slicing of the 16 x 2 and the 24 x $3\frac{1}{2}$ plates, respectively. The variation through the thickness amounts to approximately 12 ksi for the 16 x 2 plate and 15 ksi for the 24 x $3\frac{1}{2}$ plate. Thus, although the average stress in the center part of the plates is compressive (see Figs. 16 and 17), the actual stress in the interior is tensile. Similarly, while the maximum compressive stress in the average diagram of the 24 x $3\frac{1}{2}$ plate is -11 ksi, the true maximum compression at any measured point through the cross section is actually -22 ksi.

Figure 20 shows schematically the addition of stresses during welding of the 23H681 shape. The distributions shown are those measured in separate specimens of loose plates and shapes, so there is no true algebraic addition in the diagrams. The additional residual stresses resulting from the welding were obtained from gage readings on the plates before and after welding. These welding residual stresses

add to the initial stresses existing prior to welding. It should be noted that the welding stresses could be measured only in the regions which remain elastic throughout the welding and cooling after welding. In the parts of the cross section where plastic deformations occurred at any stage of the process the measured strain will contain a plastic component and cannot directly be converted to stress.

While the initial stresses in the flange plates vary between approximately -11 ksi and 50 ksi, the additional stresses as measured in the elastic part of the flanges nowhere exceed 2 ksi (Fig. 20b). For the web the comparison between initial stresses and welding stresses is similar, although the welding stresses are of a somewhat larger magnitude than encountered in the flanges, that is, up to -13 ksi. Measured welding stresses in most points were in compression. Naturally, the stress in the weld region must be in high tension, but this could not be measured directly, as explained above.

Because of the small residual stresses due to welding of this heavy shape, the distribution of the initial stresses is retained in the welded shape, only with some modifications in the magnitude of stress. Figure 21 shows the stresses as measured on both surfaces of the components of

the welded shape 23H681. The diagram can be compared directly with those in Figs. 6-9 and 11-14 for the 15H290 shape.

A full understanding of the distribution of the residual stresses in the 23H681 shape can be gained only from the results of complete sectioning and slicing, shown in Fig. 22. The diagram indicates that not only is the variation of stress across the width retained in the welded shape but also the variation across the thickness is similar to that in the loose component plates (Compare the diagram in Fig. 22 with those in Figs. 18 and 19). Major changes have occurred only in the weld area.

DISCUSSION OF RESULTS

From the results obtained on thick plates and heavy shapes in the investigation it is clear that the welding residual stresses in areas of the cross section away from the weld are far smaller in heavy welded shapes than found in the earlier investigations^(5,6,7) for small plates and shapes. Figure 23 shows a comparison between the initial residual stresses in a universal-mill plate 10" x $\frac{1}{2}$ " and the residual stresses after applying welds in the center of the plate.⁽⁵⁾ While the maximum compressive stress in the as-rolled plate is -6 ksi, the maximum compressive stress in the welded plate is -26 ksi, indicating a contribution from the welding of -20 ksi at this point. Thus, for this plate, which is representative of small and medium-size plates, the residual stresses from welding constitute the major part of the residual stress distribution.

Comparing these results with those summarized in Fig. 20, it is noted that the situation in the heavy material is quite different; the major portion of the residual stresses in the 23H681 shape are those originating from the initial plates. The maximum compressive welding stress in the flange plate is -2 ksi. The flange plate is basically a center-welded plate and may therefore be

compared directly with the center-welded plate in Fig. 23. The comparison exemplifies the observation that the welding residual stresses are of a smaller absolute and relative magnitude in heavy plates and shapes. This could also be predicted since the ratio of weld area to that of parent material is smaller for heavy practical shapes. Thus, proportionately, there is a smaller heat input for shapes of thick plates than there is for light plates, and so heavy shapes would be expected to contain compressive welding residual stresses of a smaller magnitude.

The above finding also means that the initial residual stresses existing in the component plates before welding are of greater importance for heavy shapes. This conclusion is obvious from the results obtained on the 15H290 when comparing the residual stresses in the shapes made from universal-mill plates (Figs. 6-9) and from flame-cut plates (Figs. 11-14). The only difference between the two sets of specimens is in the manufacturing procedure for the plates, so the comparison reflects the effect of this variable only.

All flanges of the 15H290 shapes made of universal-mill plates show a similar kind of distribution with high compressive stresses at the flange tips. As can be seen in Fig. 10, the compressive stresses are at the yield point

level in the flange tip corners. This is in accordance with theoretical predictions of residual stresses in universal-mill plates based upon the heat flow in cooling.⁽¹³⁾ According to the predictions, the residual stresses tend to increase with increasing size of the member. For heavy plates subjected to free cooling, the cooling residual stresses as predicted are in high compression at the plate edges and may approach the yield point for some plates.

Flame-cut plates show a reversed distribution with high tensile stresses at the flame-cut edge, balanced by compressive stresses in the center of the plate. The stress at the flame-cut surface is larger than the yield point of the parent material. This is possible because the mechanical properties of the material close to the flame-cut surface have been increased from the rapid cooling after cutting. Another factor which influences the conditions is the three-dimensional stress state. Since the local stresses in the heated material normally are in high tension, that is, of equal sign in all three directions, the material can sustain a higher stress than the yield point in a uni-axial tension test.

Basically, these conditions prevail also in the weld regions in the welded shapes, which can explain the

high tension stresses invariably experienced in the welds. However, for the weld, the weld area contains a mixture of electrode and base material. The mechanical properties of electrodes used for welding structural carbon steels normally have a higher strength than the parent material. Thus, there are three effects which explain the occurrence of high stresses in the weld areas: (1) increased strength of material due to the electrode material, (2) increased strength due to the cooling rate, and (3) three-dimensional stresses. Tension tests of specimens containing weld metal have indicated a yield strength of 50-55 ksi for A7 steel, that is, about 50% higher than the yield strength of the parent material.⁽⁵⁾ The residual stresses measured in the weld area of the heavy shapes are all of this order of magnitude.

The weld type is not a major factor in the formation of residual stresses in thick plates and shapes. A comparison of the distributions in Figs. 6 and 13, for fillet welds, and the corresponding diagrams in Figs. 7, 9, 12, and 14, for groove welds, indicates no significant difference. This is probably because the heat input in each weld pass is of the same order of magnitude for the fillet weld and the groove weld. (See Table 1). Similar results were obtained previously for small and medium-size plates.⁽⁵⁾

The residual stress distributions as measured in the shapes of A36 steel and of A441 steel are similar, indicating that the type of steel has no great influence on residual stress. Since the effect of residual stress on column strength is dependent on the ratio of residual stress to yield stress, while at the same time the magnitude of the residual stresses are not much affected by the type of material, it can be expected that columns made of high-strength steels are stronger than those made of A36 steel, also when compared on a non-dimensional basis. This has been confirmed previously by residual stress measurements and column tests on small and medium-size welded shapes.⁽¹⁴⁾

The geometry of the plates and shapes is one of the major variables affecting the residual stress distribution. As discussed above, the contribution of residual stress due to welding is greatly dependent on the size of the components, that is, whether the shape is light, medium-size, or heavy. Figure 24 summarizes the results of residual stress measurements made on a number of welded shapes using flame-cut plates, ranging from the 7H28 shape to the 23H681 shape. Generally, the residual stresses due to welding decrease with increasing size of the member.

Another feature of residual stresses in thick plates is the variation through the thickness of the components.

Results of measurements including both sectioning and slicing have shown that the variation in thick plates is considerable. For instance, the non-symmetrical application of welds on a flange plate results in high tensile stresses on the welded side, whereas the stress at the opposite side often is compressive. It is believed that the large variation of stress across the thickness for the component plates 24" x 3 $\frac{1}{2}$ " and 16" x 2" (Figs. 18 and 19) remains from the cooling after rolling of the parent plate. Theoretical predictions of cooling stresses in rolled plates of a similar size show a distribution of stress through thickness of the plate very close to that measured in the center of these flame-cut plates.⁽¹³⁾ Also, the variation across the width for the center portion of the plates appears to be influenced by the initial stresses from the cooling after rolling of the parent plates. If there were no initial stresses before flame-cutting of the plates, the stress distribution in the center portions of the plates would approximate a plane, except for the heated and yielded regions at the flame-cut edges, where tensile stresses are introduced. The measured distributions, however, show a variation across the plate width of 10 ksi and 13 ksi for the center portions of the 16" x 2" and 24" x 3 $\frac{1}{2}$ " plates, respectively. The

actual type of distribution in the center of the plates, with higher compressive stresses towards the edges, is consistent with predictions of cooling stresses in similar rolled plates.⁽¹³⁾

This means that the stresses in thick flame-cut plates result from both the cooling after rolling of the parent plate and the local heat input in the flame-cutting process.

Thus, the residual stress distribution in a fabricated member of thick component plates generally is a complex superimposed pattern resulting from the different stages of manufacture and fabrication procedures. That is, cooling residual stresses after rolling, residual stresses from flame-cutting as well as the welding residual stress and any other procedure employed in the manufacture and fabrication will influence the final residual stress distribution in a heavy welded shape. However, since the welding residual stresses in heavy welded shapes are small, except in the weld region, residual stresses in such shapes may be predicted by determining the initial stresses in the component plates from existing data or from measurements and estimating the additional residual stresses due to welding. This is a further simplification of the finding obtained previously for smaller shapes that the residual stresses in a welded shape can be predicted from a knowledge of the residual stress distribution in the separate component plates

with simulated weld beads.⁽⁷⁾

The relationship between initial residual stresses in component plates and welding residual stresses implies that efforts to limit residual stresses in heavy welded shapes should be directed towards the manufacture of the component plates. Thus, by using flame-cut plates in heavy welded shapes, there is a prospect for an increase in strength when compared with lighter members at the same slenderness ratio. On the other hand, the column strength of heavy columns made of universal-mill plates with as-rolled edges may be lower, in particular for A36 steel and at higher slenderness ratios.⁽¹⁶⁾

For heavy welded columns made of flame-cut plates, there is even a possibility that such welded shapes may be stronger than their rolled counterparts. Figure 25 shows the measured distribution of residual stress in a rolled shape 14WF426.⁽¹⁷⁾ The nominal strength characteristics of this shape fall in between those of the two welded shapes 15H290 and 23H681 studied here. The stresses are very high, of a similar distribution and order of magnitude as in the welded shape 15H290 made of universal-mill plates.

The favorable indications for the strength of heavy welded columns made of flame-cut plates is in contrast

with previously published results for small and medium-size welded shapes of universal-mill plates which proved to be weaker than their rolled counterparts.⁽⁶⁾ However, since the present basis for the implications on heavy column strength is limited to the few specimens studied, the statements are preliminary; the general conclusions will be developed further when the current research program is completed.

CONCLUSIONS

The purpose of this study was to investigate experimentally the magnitude and distribution of residual stress in heavy column shapes built up by welding plates with thickness in the range of $1\frac{1}{2}$ to $3\frac{1}{2}$ inches. Two shapes were investigated : a 15H290 shape and a 23H681 shape. For the smaller shape comparative tests were conducted to study the influence of the manufacture of plates, weld type, and yield strength of the material. The specimens referred to in this paper constitute the first phase of a major research program concerning residual stresses in thick welded plates.

Based on the results of this first phase of the program, the following conclusions can be stated:

1. The residual stress distribution in a fabricated member of thick component plates generally is a complex superimposed pattern resulting from the different stages of manufacture and fabrication procedures. That is, cooling residual stresses from the rolling of the parent plates, residual stresses from flame-cutting the plates, as well as the residual stresses from the welding process, all influence the final residual stress distribution in a welded shape.

2. The welding residual stresses in portions of the cross section other than the weld area tend to decrease with increasing size of the member, probably because the weld area, and consequently, the heat input, is relatively smaller in heavy plates and shapes as compared to light members.

3. The results of comparative measurements on 15H290 shapes indicate that the weld type (penetration) is not a major factor in the formation of residual stresses in heavy plates and shapes, as long as the heat input is not drastically changed.

4. The residual stress distributions as measured in shapes of ASTM A36 steel and of A441 steel are similar, indicating that the yield strength of the steel has no great influence on residual stresses in heavy shapes.

5. The magnitude and distribution of initial residual stresses depends greatly on the manufacturing procedure, that is, universal-mill plates or flame-cut plates.

6. The geometry of the plates and shapes is one of the major variables affecting the residual stress distribution. More specifically, the residual stresses will depend upon whether the shape is light, medium-sized or heavy (effect of size of cross section) or whether the plates are narrow, medium or wide (effect of width to thickness ratio).

7. Residual stresses due to cooling after rolling of a plate normally are compressive at the edges, balanced by tension stresses in the center portion of the plate. Measurements on four welded H-shapes, 15H290, containing universal-mill plates indicate that the initial stresses in the flange plates are very high. This conforms to the observation made previously from the results of theoretical predictions that the cooling residual stresses in rolled plates tend to increase with increasing size of the plate.

8. Residual stresses due to flame-cutting are in high tension at the flame-cut edge due to the local heat input. For the flame-cut plates studied, the stress at the burned surface is about 50% above the yield point of the parent material. The tensile stresses are balanced by compression in the center part of the plate; the distribution of residual stresses in the center of a heavy flame-cut plate is dependent also on the initial stresses due to rolling.

9. The variation of residual stress across the thickness of plates more than one inch thick can be considerable. Such variation will result in a plate with welds deposited on one side of the plate; also, a significant difference can be expected between stresses in the surface and the interior of heavy rolled plate components.

10. The relationship between the initial residual stresses in component plates and the welding residual stresses implies that the welding stresses in thick welded plates and shapes are of less importance than the initial stresses existing prior to welding. Efforts to limit residual stresses in heavy welded shapes should be directed towards the manufacture of the component plates.

11. Since the welding residual stresses in heavy welded shapes are small, except in the weld region, residual stresses in such shapes may be predicted by determining the initial stresses in the component plates from existing data or from measurements, and estimating the additional residual stresses due to welding. This is a further simplification of the finding obtained previously for smaller shapes that the residual stresses in a welded shape can be predicted from a knowledge of the residual stress distribution in the separate component plates with simulated weld beads.⁽⁷⁾

The effect of residual stresses on the load-carrying behavior and strength of heavy columns will be discussed further in a future paper.⁽¹⁶⁾ Briefly, by using

flame-cut plates in heavy welded shapes, there is a prospect for an increase in strength when compared with lighter members at the same slenderness ratio. Under certain circumstances, there is even a possibility that such welded shapes may be stronger than their rolled counterparts, which is the opposite relationship as compared to the situation for small and medium-sized shapes. On the other hand, heavy welded columns of universal-mill plates and A36 steel are expected to show a lower column strength, especially for columns of a medium to high slenderness ratio.

ACKNOWLEDGMENTS

This paper presents the results of an experimental study of residual stresses in heavy welded shapes. The investigation is the first phase of a major research program designed to determine the residual stresses in thick welded plates and shapes and to relate this to the stability under load of compression members.

The investigation was conducted at Fritz Engineering Laboratory, Lehigh University, Bethlehem, Pennsylvania. The National Science Foundation sponsors the current research program. A pilot study, included in this paper, was part of a project sponsored jointly by the Pennsylvania Department of Highways, the Bureau of Public Roads of the U. S. Department of Commerce, the Column Research Council, the American Institute of Steel Construction, and the American Iron and Steel Institute. The specimens were fabricated by the Bethlehem Steel Corporation, and thanks are due to that corporation and its personnel who assisted in the design and fabrication of the specimens. The guidance of Task Group 1 of the Column Research Council, under the chairmanship of John A. Gilligan, is gratefully acknowledged.

Special thanks are due to Lynn S. Beedle, Director of Fritz Engineering Laboratory, for his advice and

encouragement throughout the program. Fiorello R. Estuar and William C. Cranston carried out the experiments on the 15H290 shape and Charles R. Nordquist assisted in the measurements on the 23H681 shape and its component plates. Their assistance is sincerely appreciated.

Thanks are also due to Kenneth R. Harpel, laboratory foreman, and his staff for the preparation of the test specimens, to Mrs. Sharon Balogh for the preparation of the drawings, and to Miss Joanne Mies and Mrs. Linda Welsch for their care in typing the manuscript.

337.12

-35

TABLES AND FIGURES

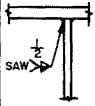
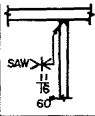
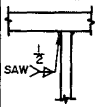
Test Specimen No.	Shape Designation	Material	Static Yield Stress ^a (ksi)	Manufacture of Plates FC/UM	Size of Flange Plate (inch)	Size of Web Plate (inch)	Welding Method and Weld Type	Detail of Weld	No. of Passes for each Weld	Sequence of Weld Passes	Welding Data											
											Pass No.	Voltage (Volts)	Current (Amps)	Speed (ipm)								
1	15H290	A36	33.7	UM	14x2½	10x1½	SAW, fillet		2	<table border="1" style="display: inline-table; vertical-align: middle;"><tr><td>8,4</td><td>1,5</td></tr><tr><td>6,2</td><td>3,7</td></tr></table>	8,4	1,5	6,2	3,7	1-4 5-8	33 33	650 650	26 14				
8,4	1,5																					
6,2	3,7																					
2	15H290	A36	36.0	UM	14x2½	10x1½	SAW, groove		7	<table border="1" style="display: inline-table; vertical-align: middle;"><tr><td>16,9,8,2,</td><td>4,5,12,5,</td></tr><tr><td>25,24,17</td><td>20,21,28</td></tr><tr><td>27,22,19,</td><td>18,23,26,</td></tr><tr><td>14,11,63</td><td>1,7,10,15</td></tr></table>	16,9,8,2,	4,5,12,5,	25,24,17	20,21,28	27,22,19,	18,23,26,	14,11,63	1,7,10,15	1-2 3-4 5-28	32 33 33	500 650 650	24 18 16
16,9,8,2,	4,5,12,5,																					
25,24,17	20,21,28																					
27,22,19,	18,23,26,																					
14,11,63	1,7,10,15																					
3	15H290	A441	46.7	UM	14x2½	10x1½	SAW, fillet		SEE	TEST SPECIMEN	NO. 1											
4	15H290	A441	45.2	UM	14x2½	10x1½	SAW, groove		SEE	TEST SPECIMEN	NO. 2											
5	15H290	A36	35.9	FC	14x2½	10x1½	SAW, fillet		SEE	TEST SPECIMEN	NO. 1											
6	15H290	A36	35.9	FC	14x2½	10x1½	SAW, groove		SEE	TEST SPECIMEN	NO. 2											
7	15H290	A441	44.6	FC	14x2½	10x1½	SAW, fillet		SEE	TEST SPECIMEN	NO. 1											
8	15H290	A441	42.0	FC	14x2½	10x1½	SAW, groove		SEE	TEST SPECIMEN	NO. 2											
9	PL16x2	A36	32.5	FC																		
10	PL24x3½	A36	32.1	FC																		
11	23H581	A36	32.2	FC	24x3½	16x2	SAW, fillet		1	<table border="1" style="display: inline-table; vertical-align: middle;"><tr><td>2</td><td>2</td></tr><tr><td>1</td><td>1</td></tr></table>	2	2	1	1	1st DC Fl. AC 2nd DC Fl. AC	26 31 26 30	700 530 710 530	15 15 18 18				
2	2																					
1	1																					

^a Weighted Average

TABLE 1. DATA OF TEST SPECIMENS

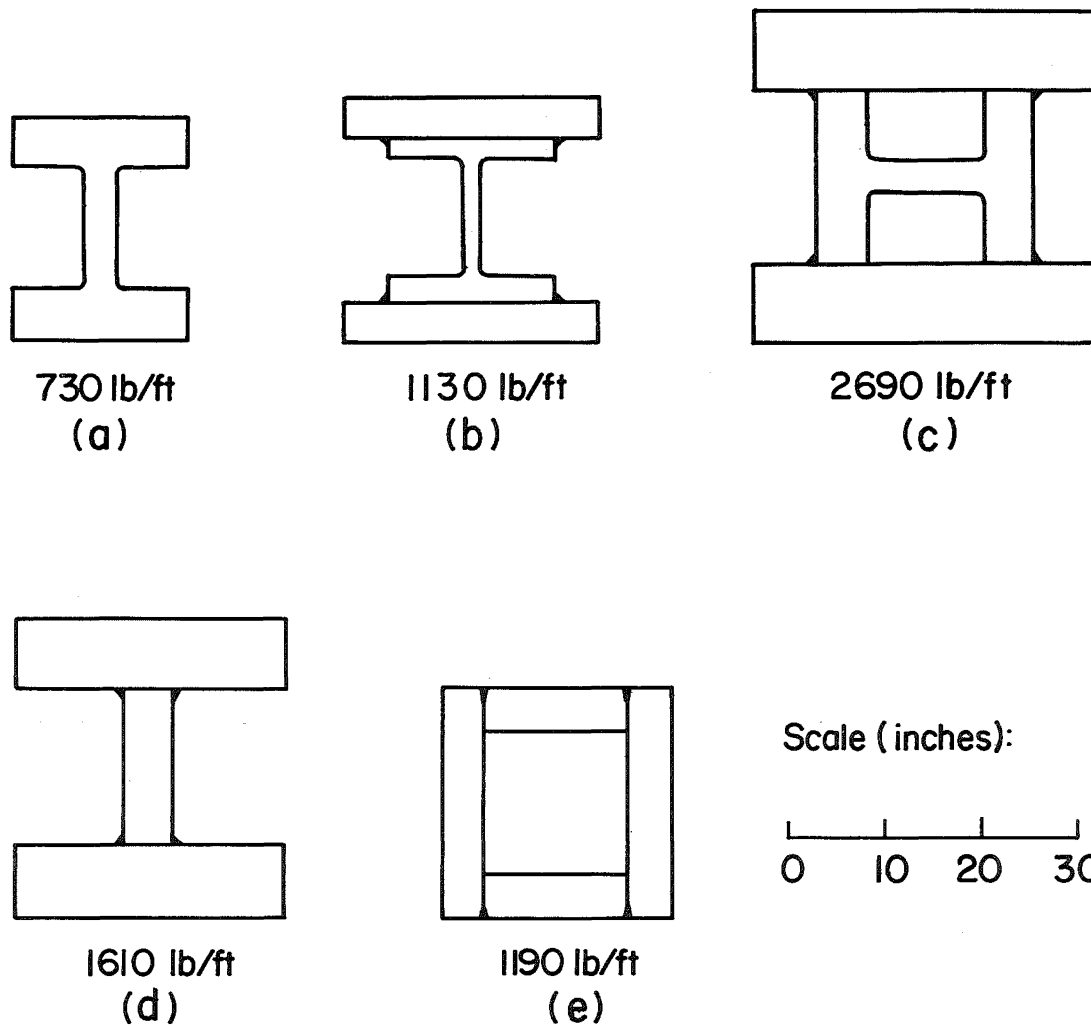

Fig. 1 Heavy Column Shapes in Existing Structures

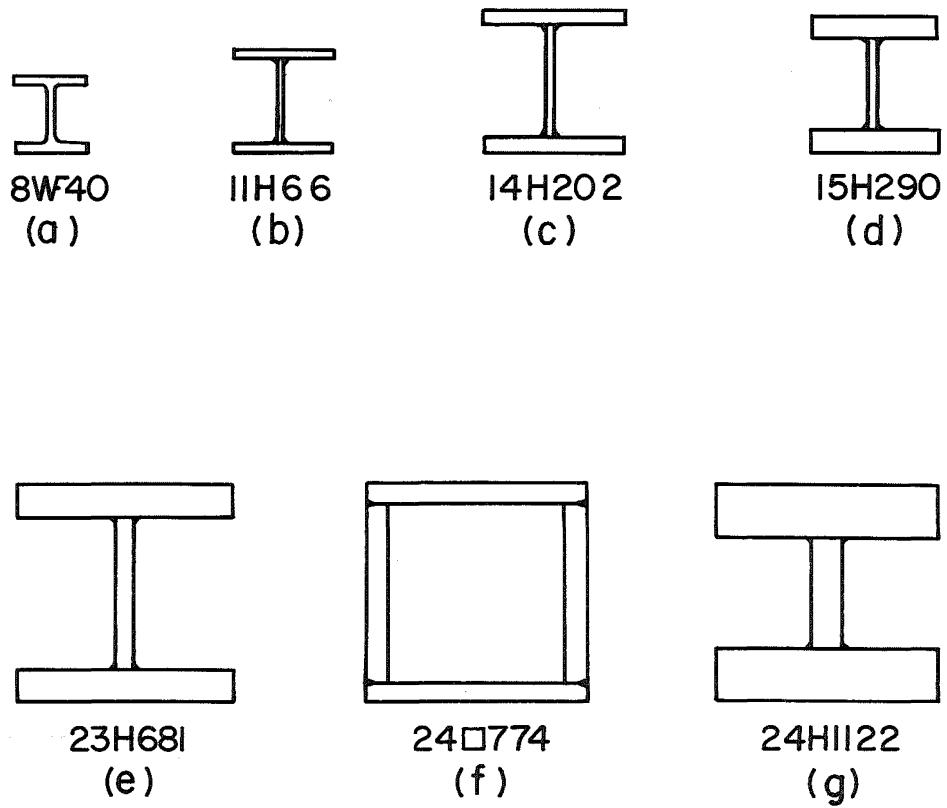

Fig. 2 Test Columns

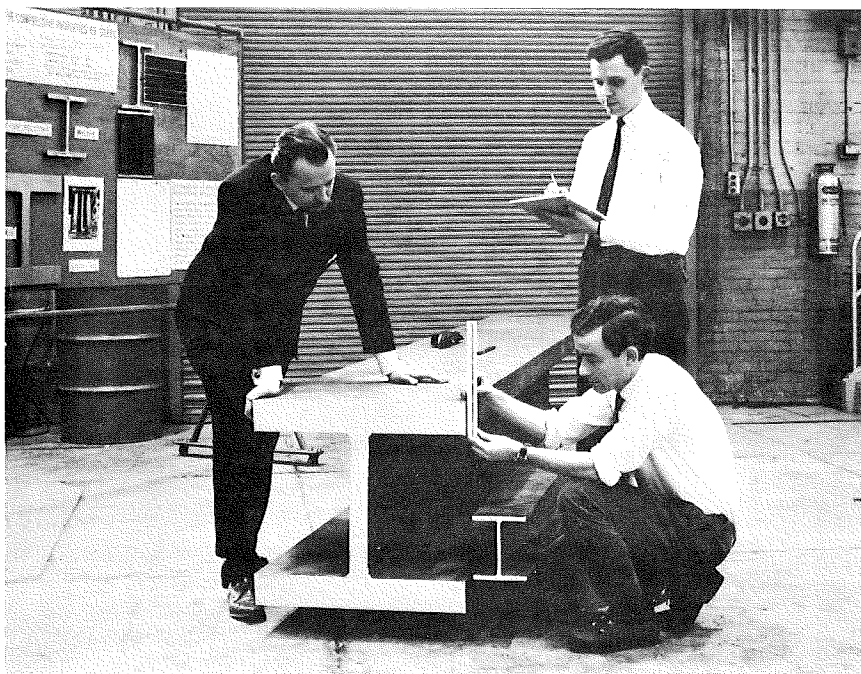

Fig. 3 Largest (23H681) and smallest (7H28) column shapes tested so far in the research program

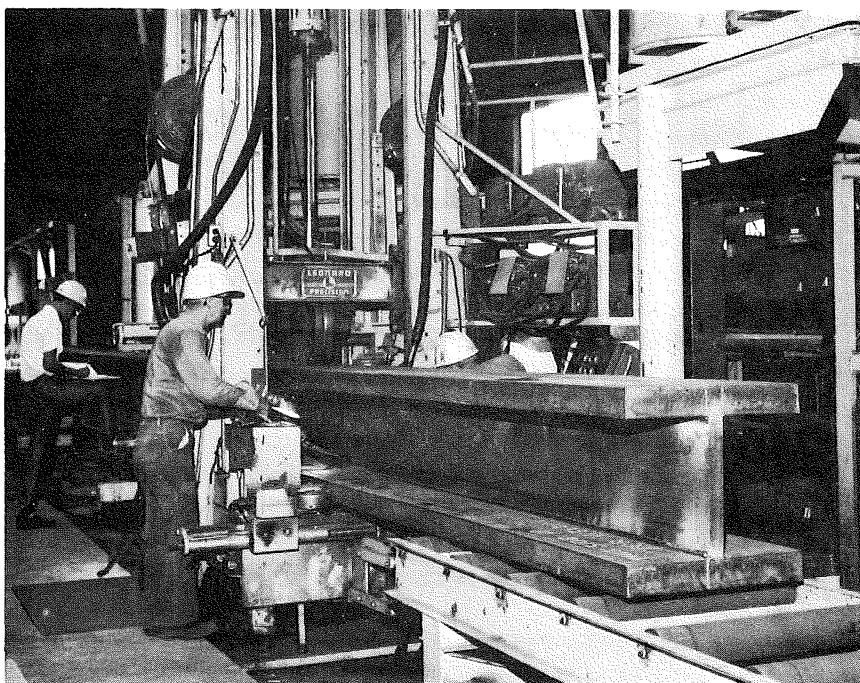

Fig. 4 Fabrication of the Welded H-Shape 23H681 (Courtesy Bethlehem Steel Corporation).

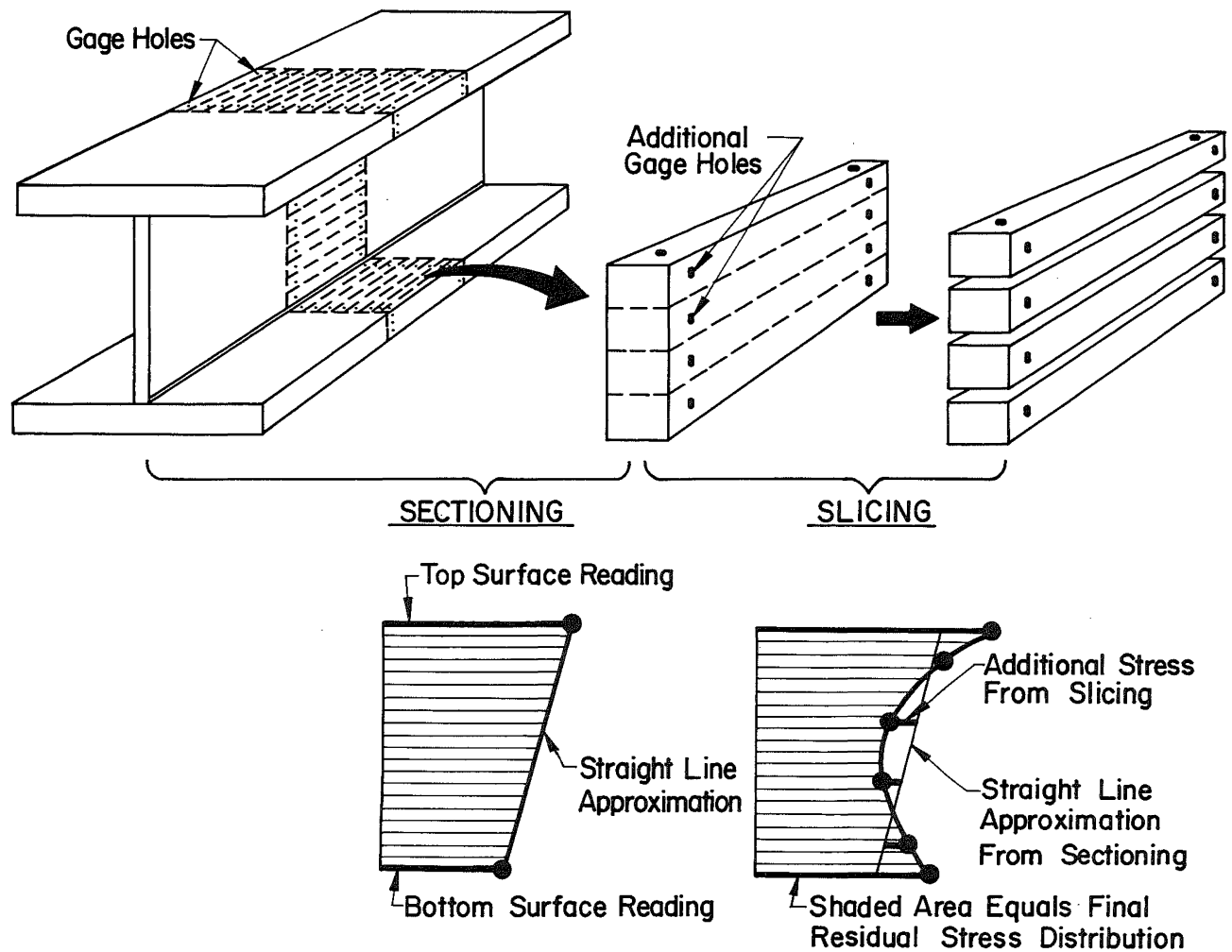

Fig. 5 Principle of the Sectioning Method for Residual Stress Measurements

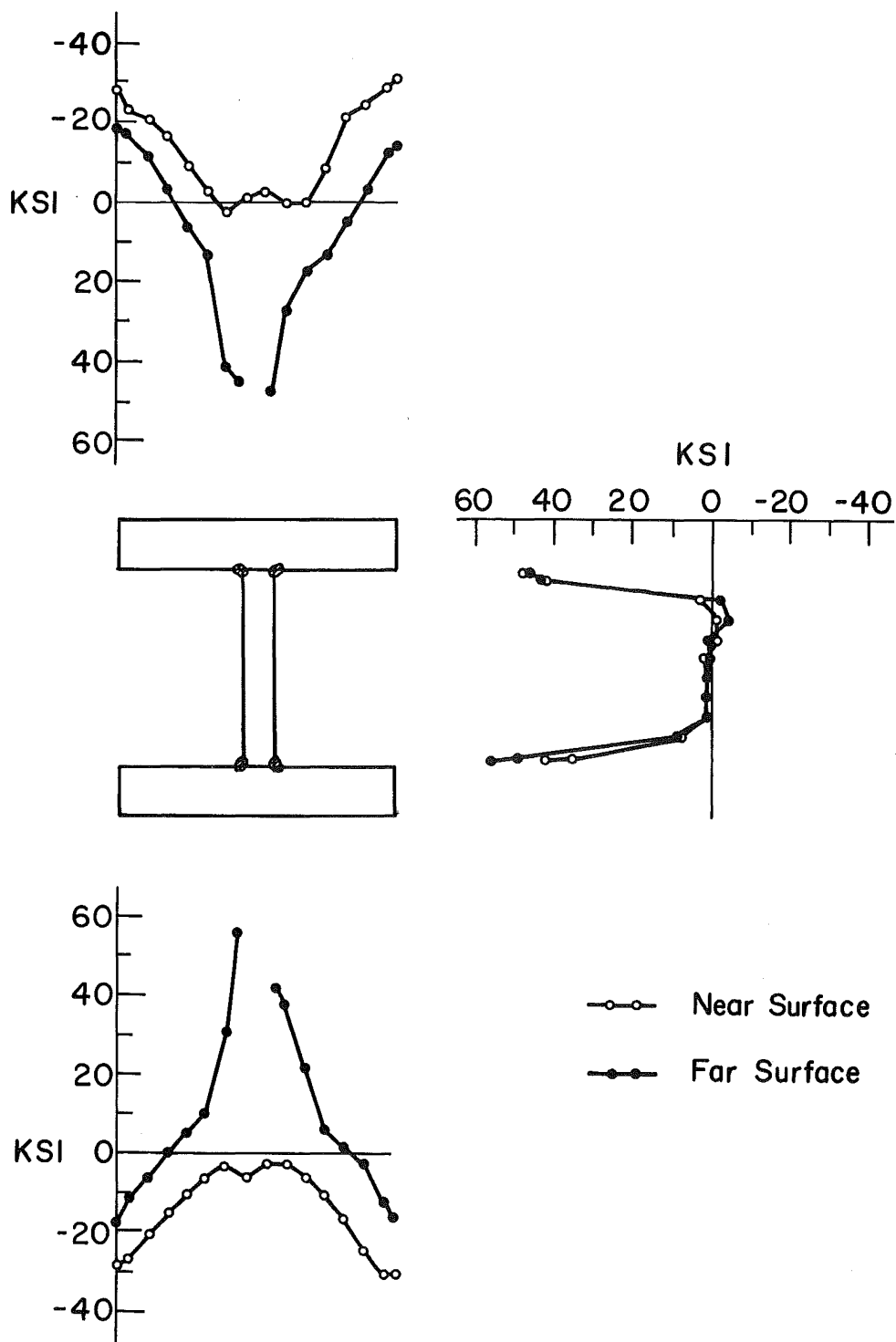

Fig. 6 Residual Stresses in a Welded Shape 15H290.
Universal-Mill Plates, A36 Steel, 1/2" Fillet Welds.

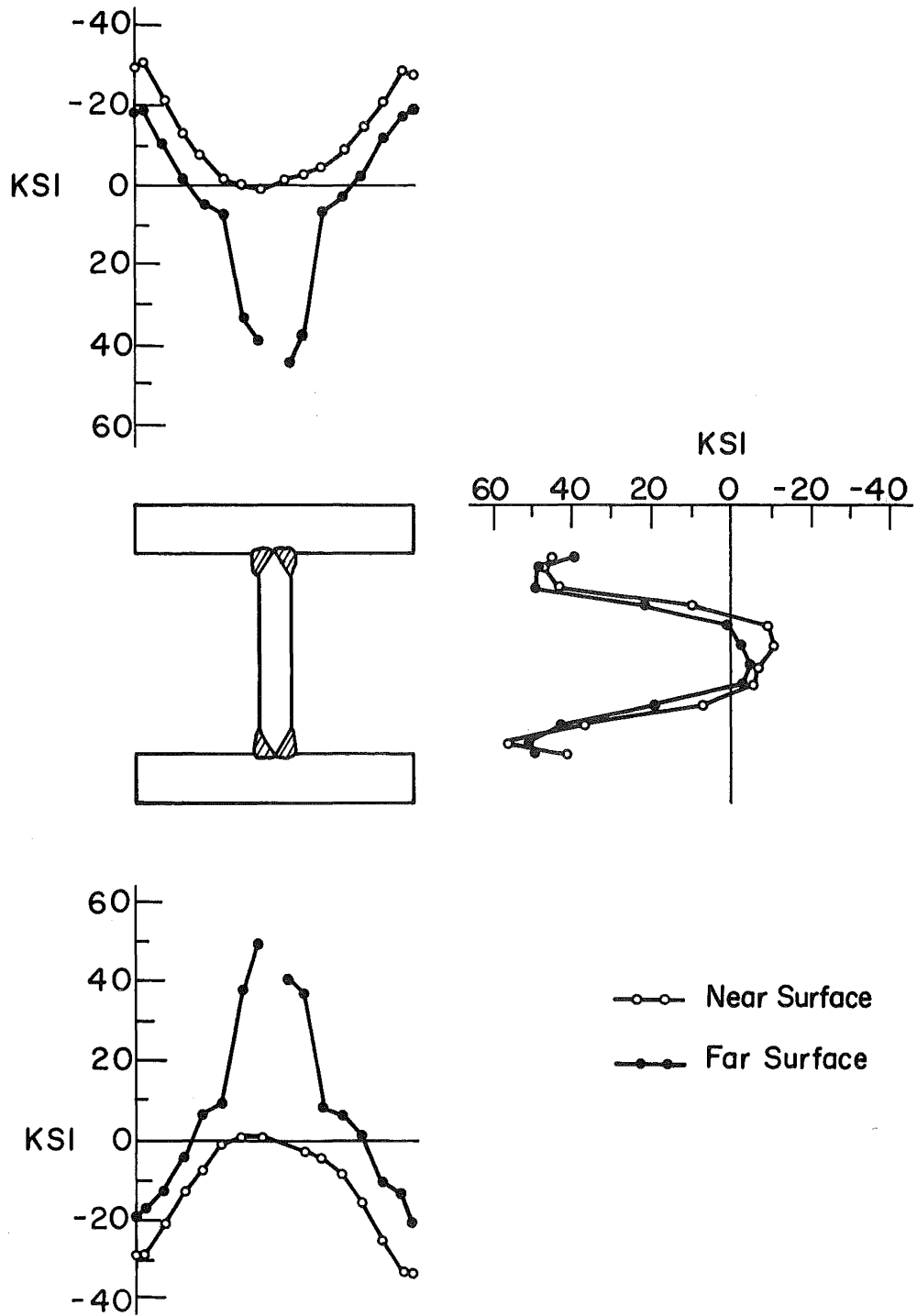

Fig. 7 Residual Stresses in a Welded Shape 15H290. Universal-Mill Plates, A36 Steel, 11/16" Groove Welds.

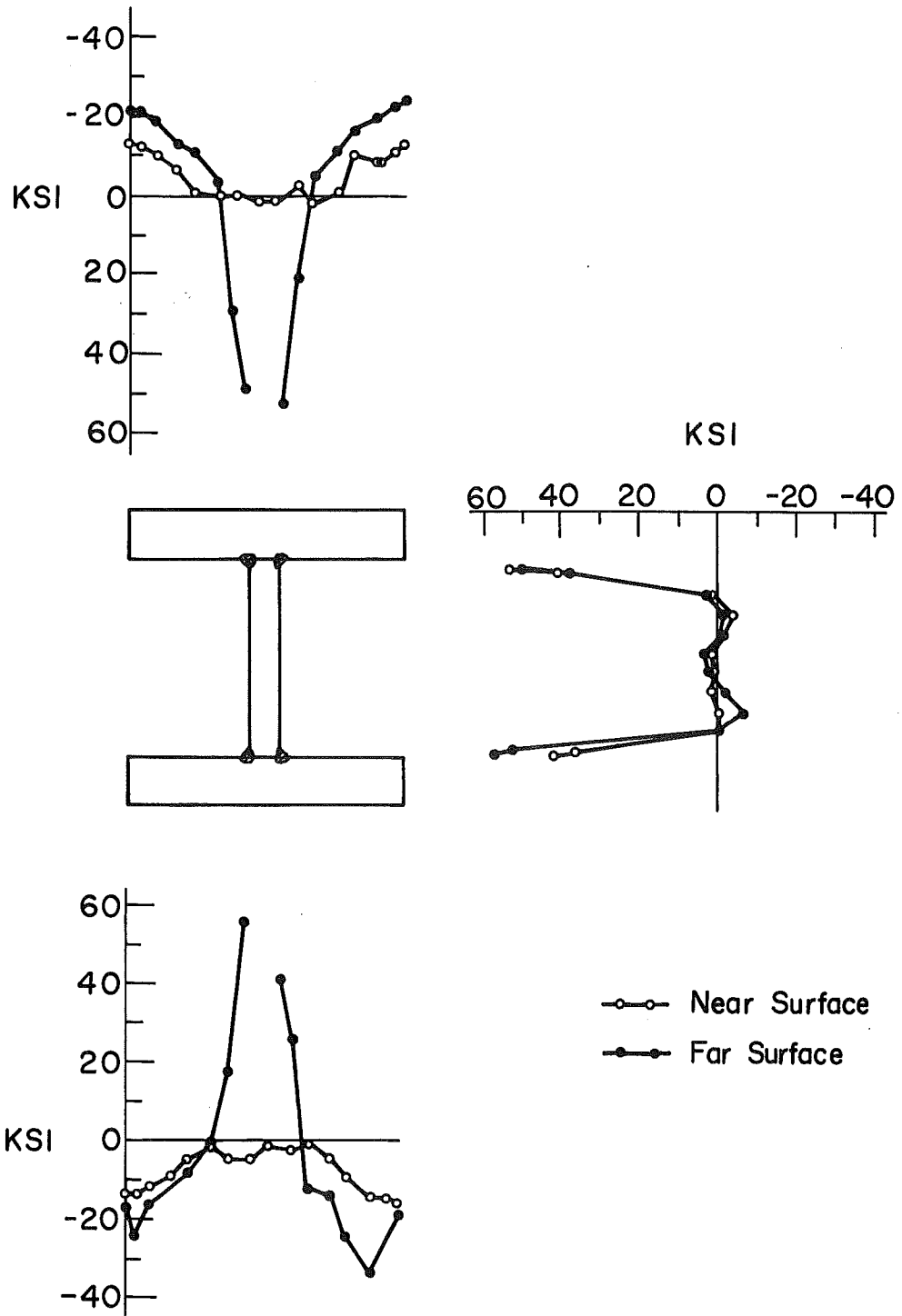

Fig. 8 Residual Stresses in a Welded Shape 15H290 Universal-Mill Plates, A441 Steel, 1/2" Fillet Welds.

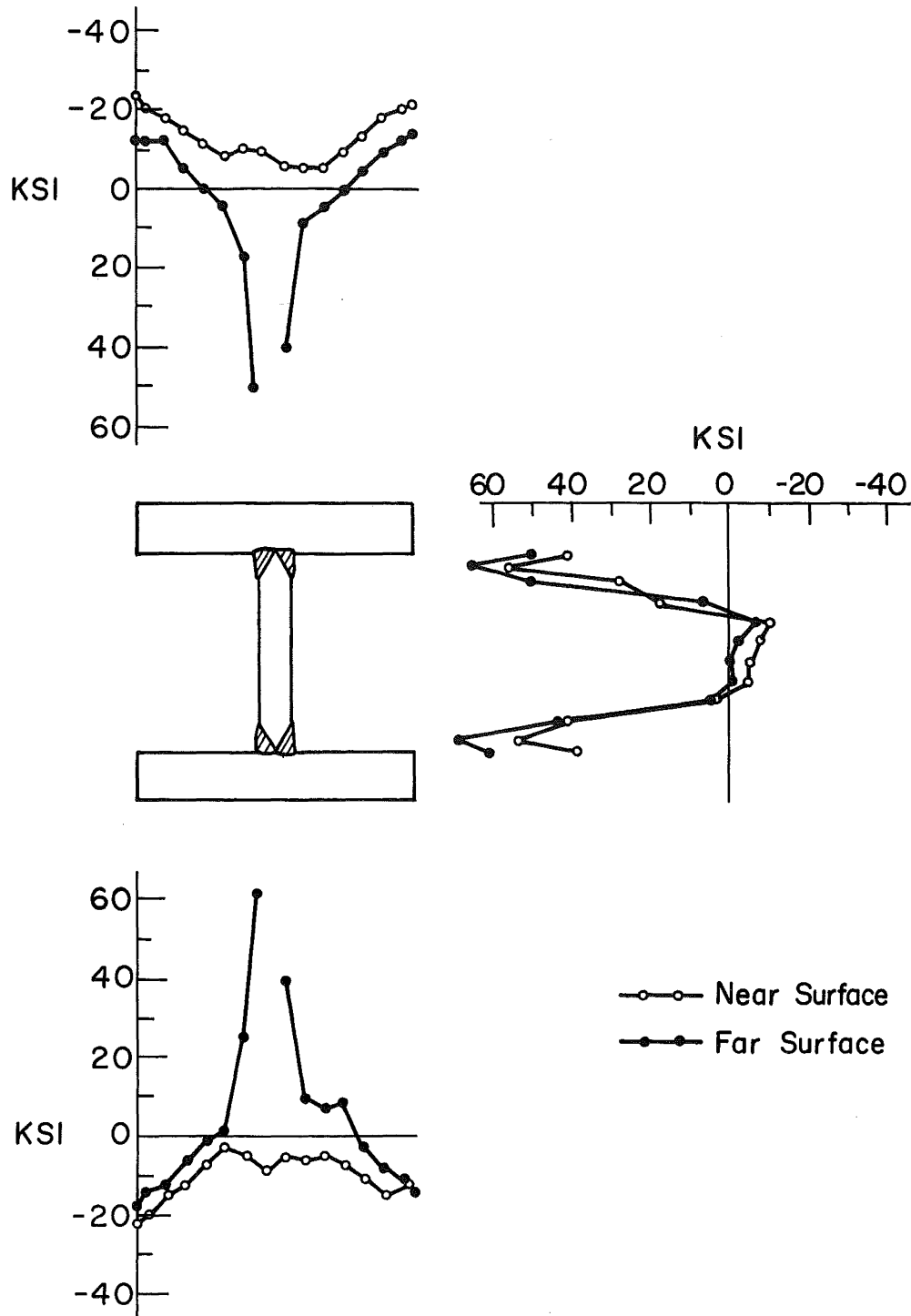

Fig. 9 Residual Stresses in a Welded Shape 15H290. Universal-Mill Plates, A441 Steel, 11/16" Groove Welds.

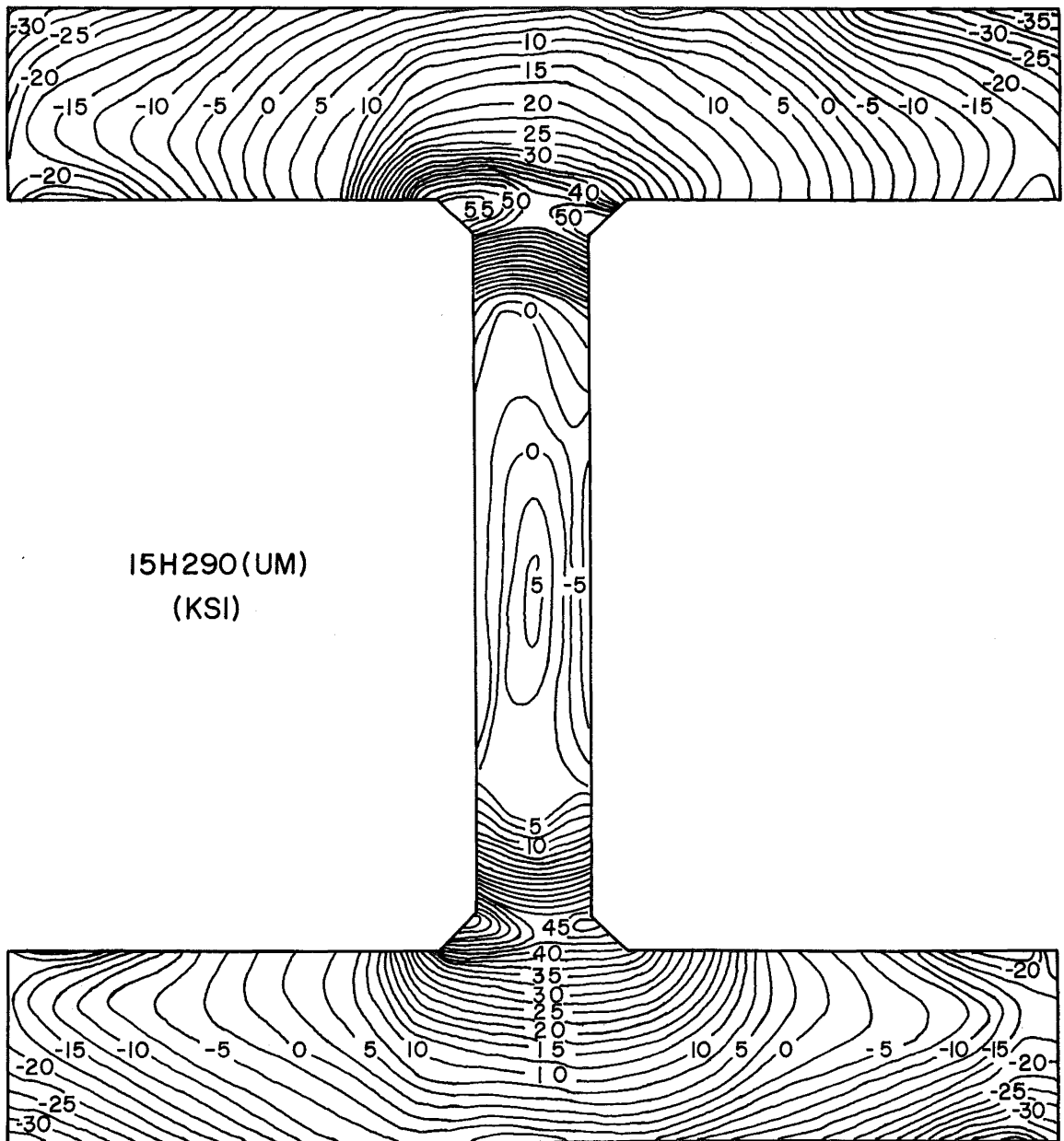

Fig. 10 Two-Dimensional Variation of Residual Stress in a Welded Shape 15H290. Universal-Mill Plates, A36 Steel, 1/2" Fillet Welds.

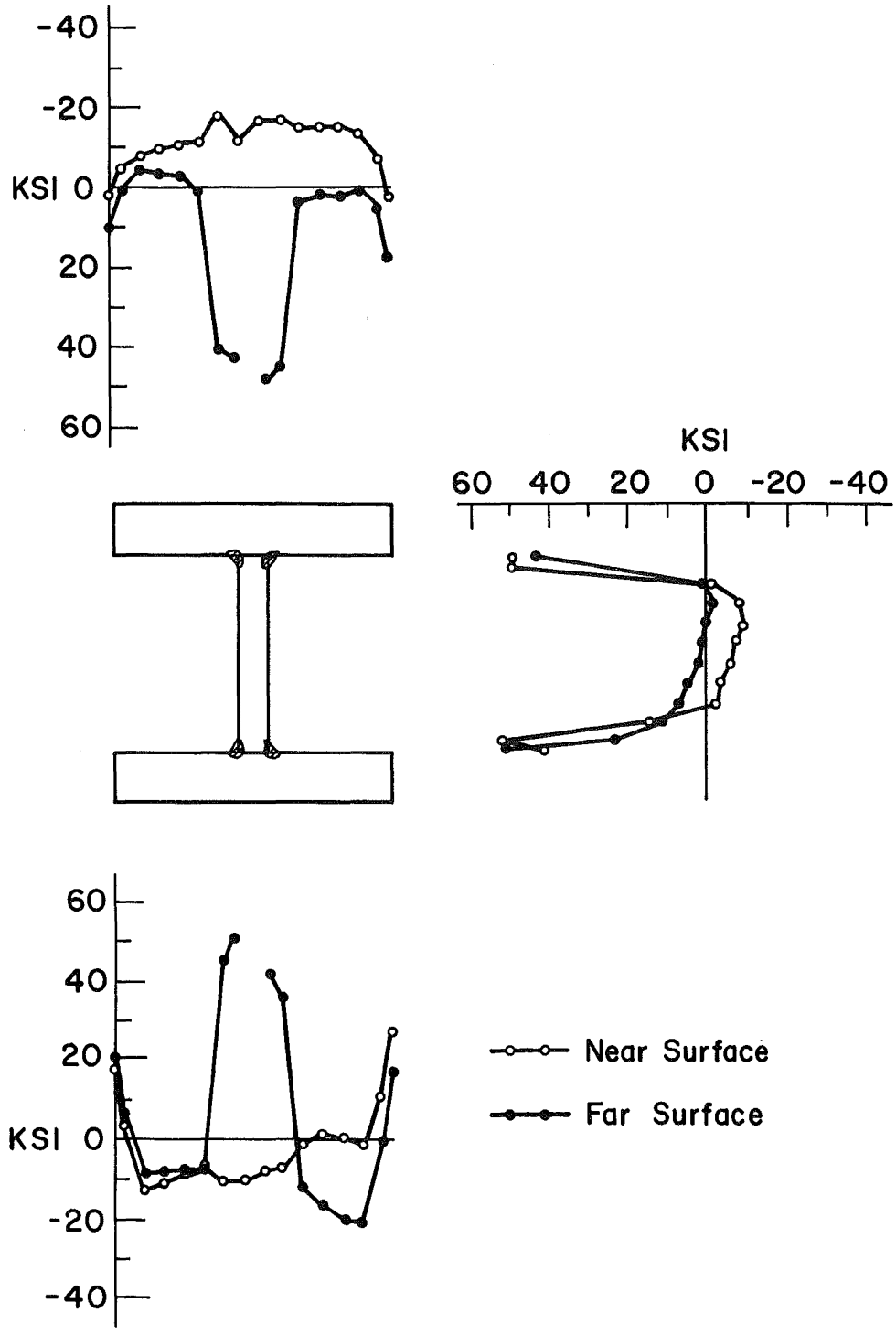

Fig. 11 Residual Stresses in a Welded Shape 15H290. Flame-Cut Plates, A36 Steel, 1/2" Fillet Welds.

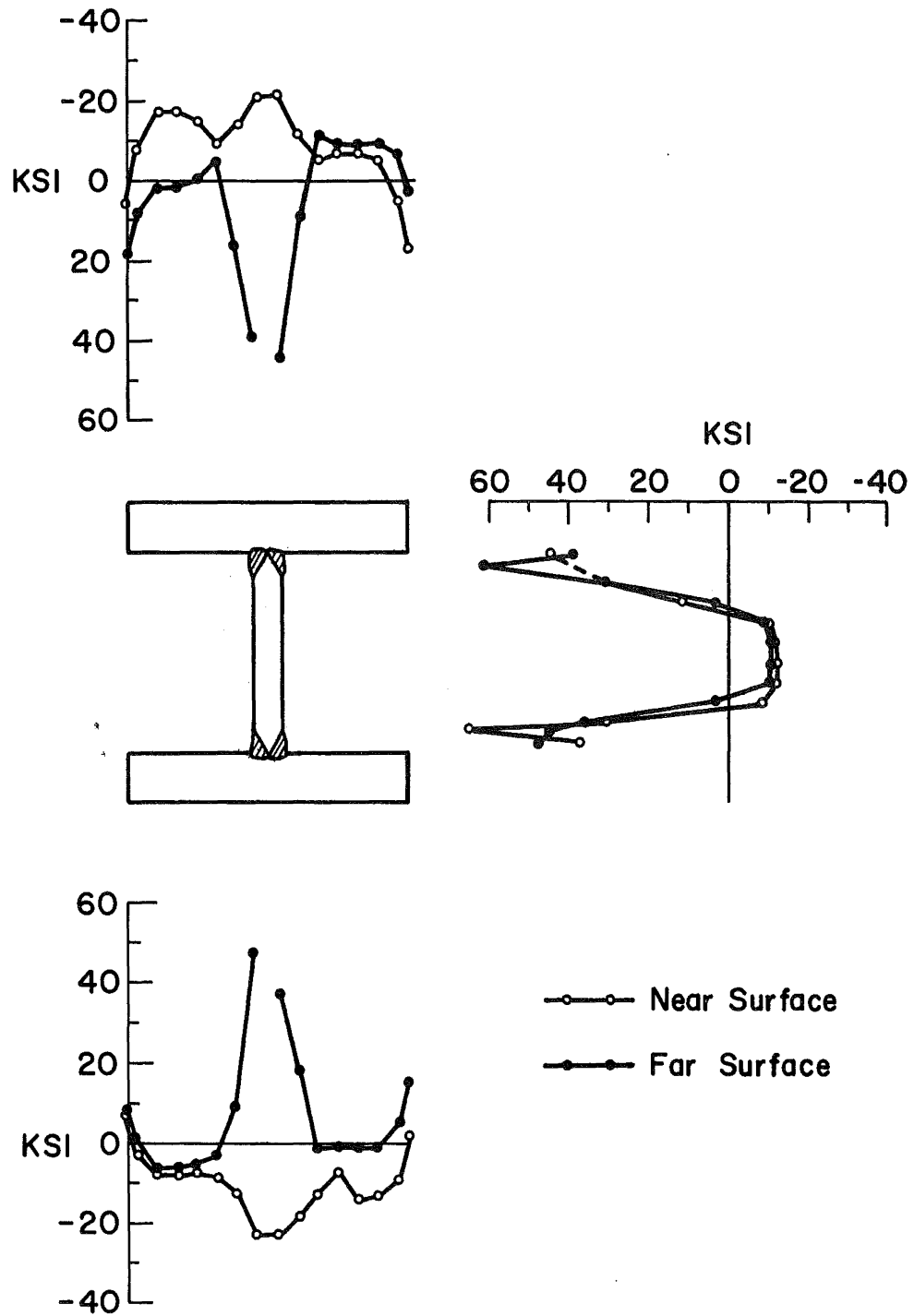

Fig. 12 Residual Stresses in a Welded Shape 15H290.
Flame-Cut Plates, A36 Steel, 11/16"
Groove Welds.

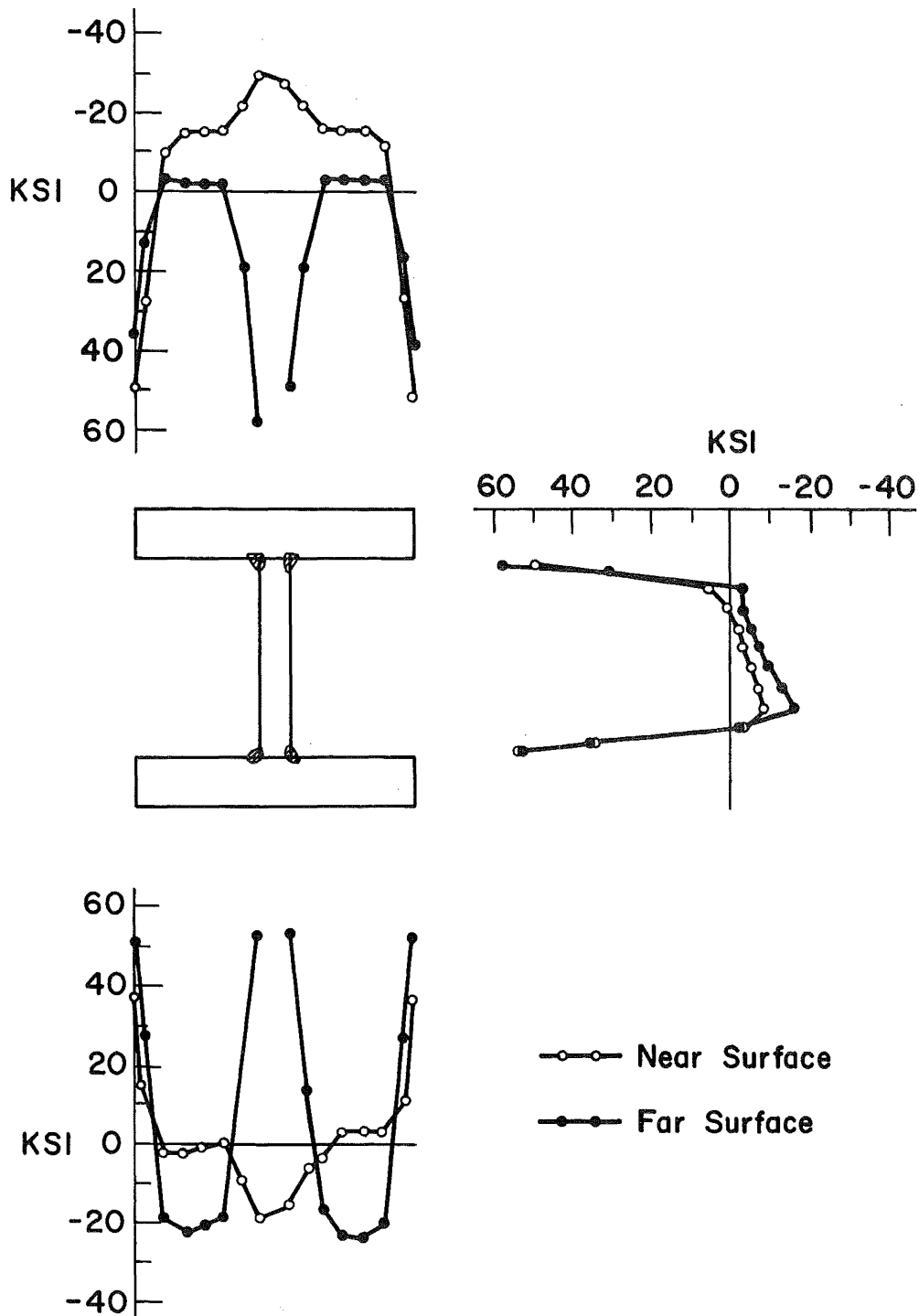

Fig. 13 Residual Stresses in a Welded Shape 15H290. Flame-Cut Plates, A441 Steel, 1/2" Fillet Welds.

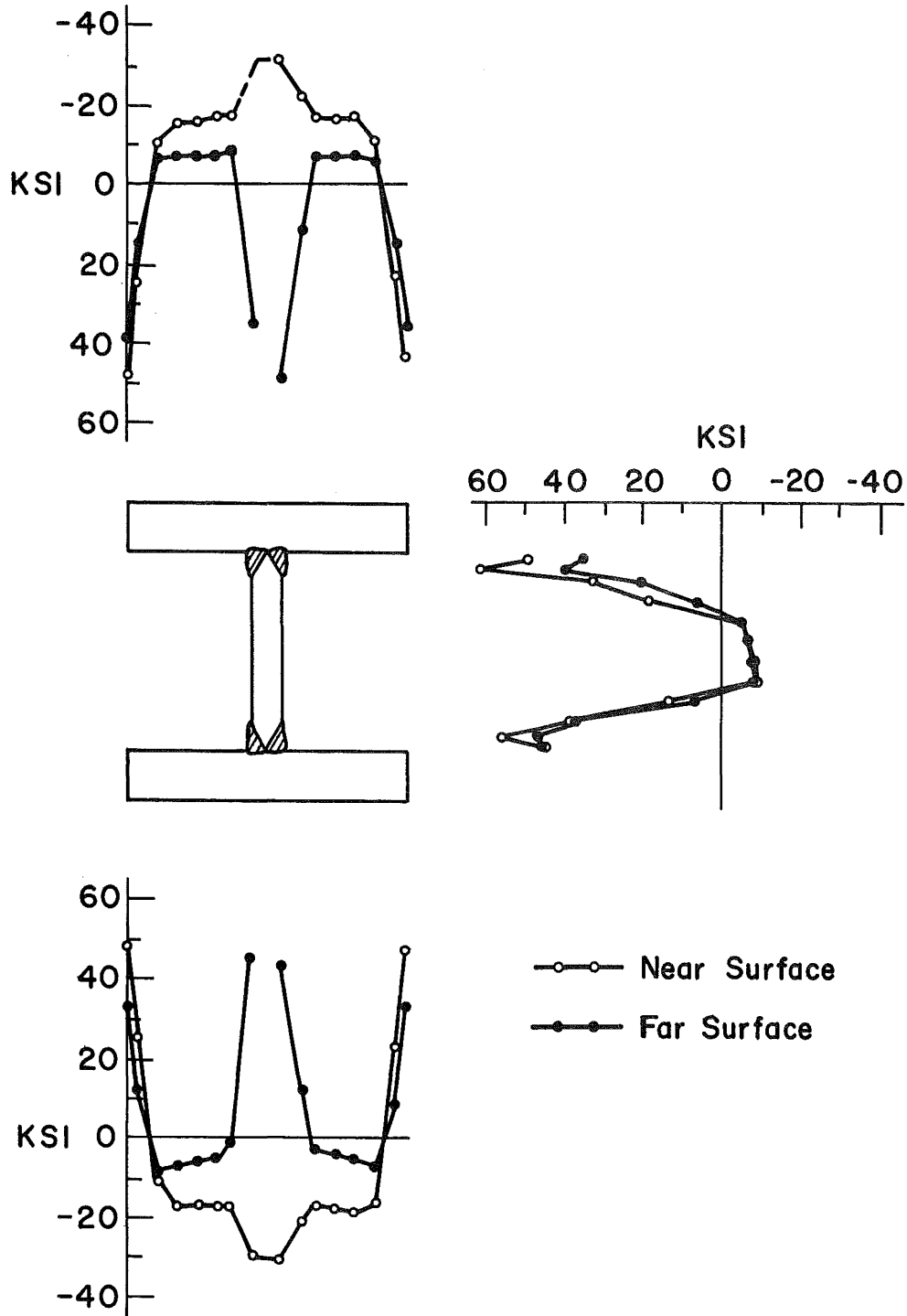

Fig. 14 Residual Stresses in a Welded Shape 15H290. Flame-Cut Plates, A441 Steel, 11/16" Groove Welds.

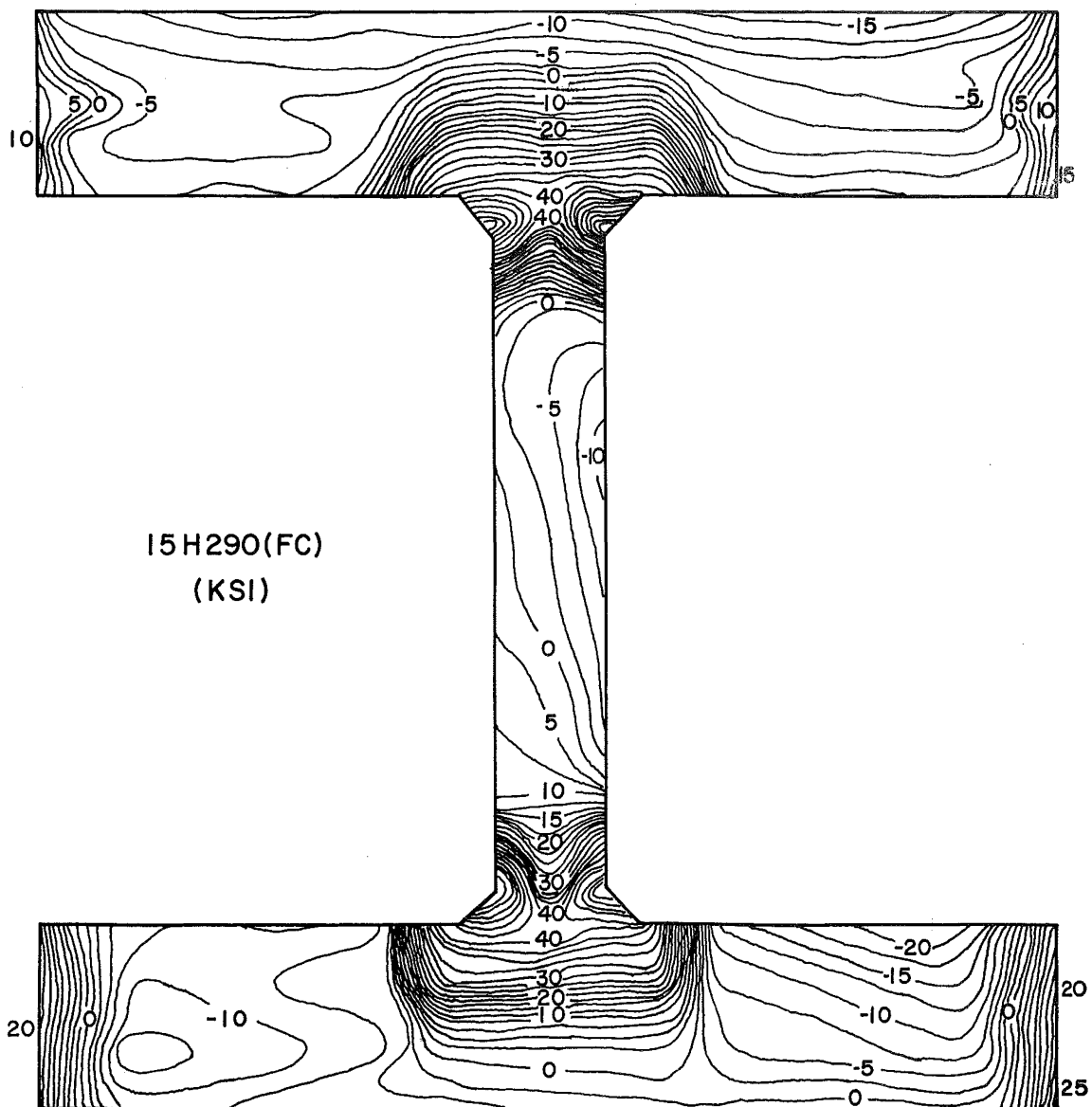

Fig. 15 Two-Dimensional Variation of Residual Stress in a Welded Shape 15H290. Flame-Cut Plates, A36 Steel, 1/2" Fillet Welds.

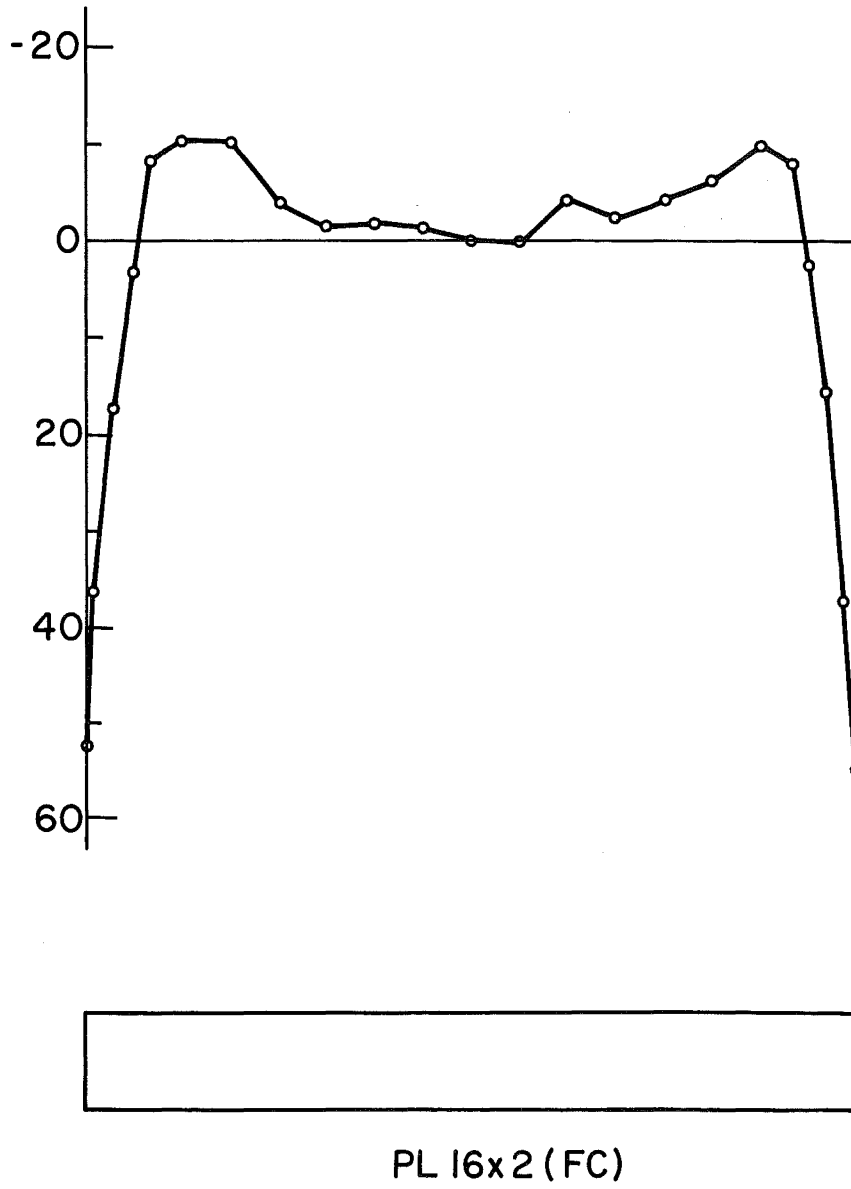
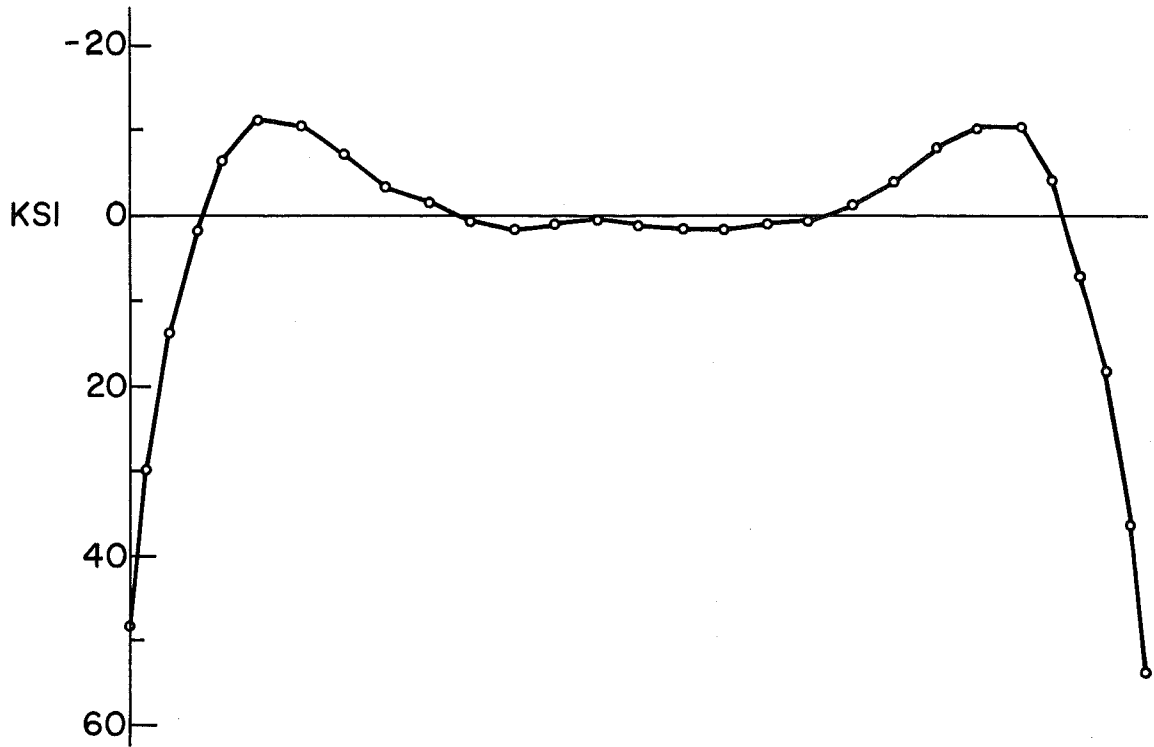

Fig. 16 Residual Stresses in a Flame-Cut Plate 16" x 2"



PL 24x 3 1/2 (FC)

Fig. 17 Residual Stresses in a Flame-Cut Plate 24" x 3 1/2"

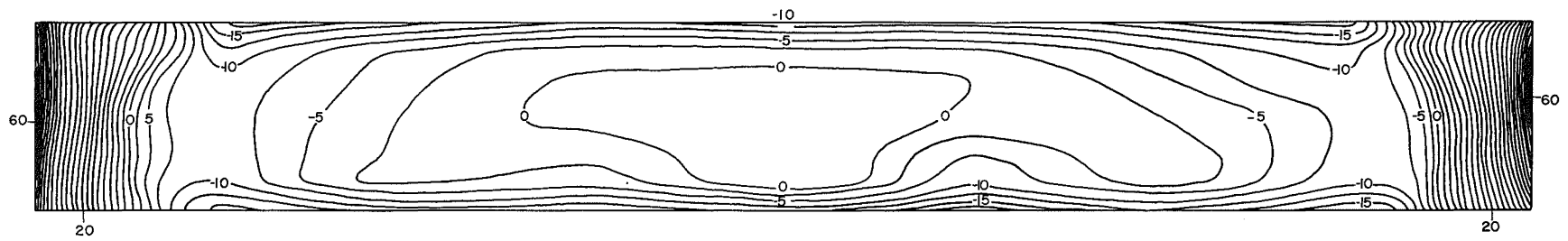

Fig. 18 Two-Dimensional Variation of Residual Stress
in a Flame-Cut Plate 16" x 2"

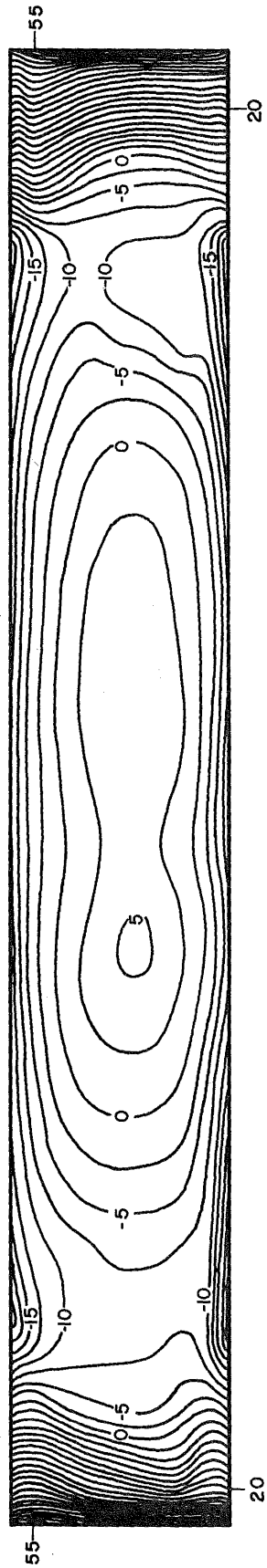
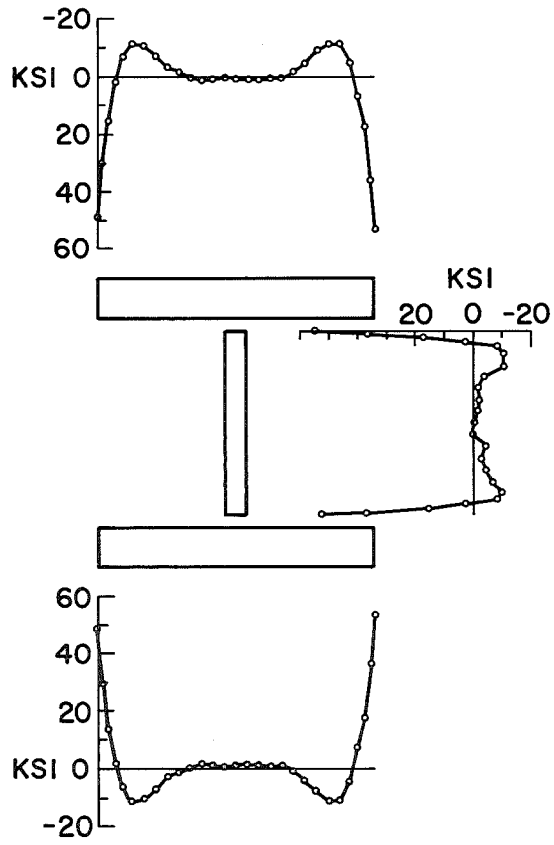
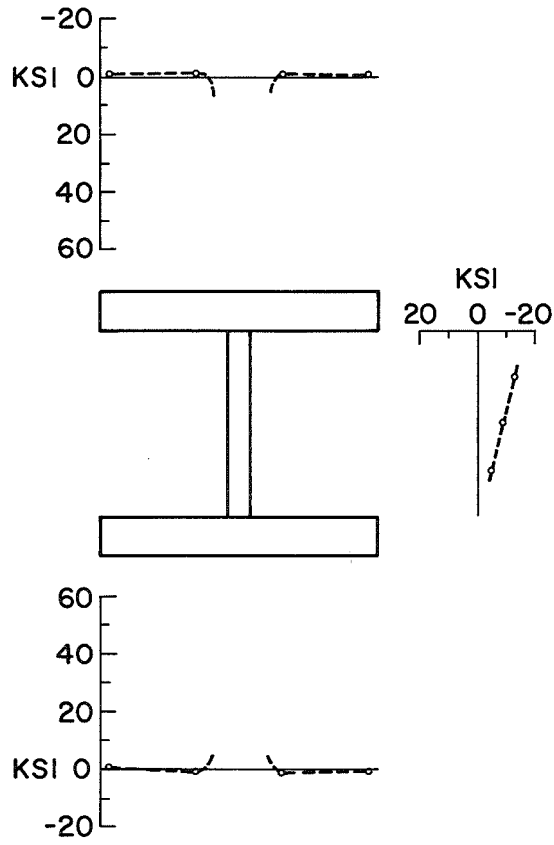

Fig. 19 Two-Dimensional Variation of Residual Stress
in a Flame-Cut Plate 24" x 3 $\frac{1}{2}$ "



(a) INITIAL RESIDUAL STRESSES



(b) ADDITIONAL WELDING STRESSES

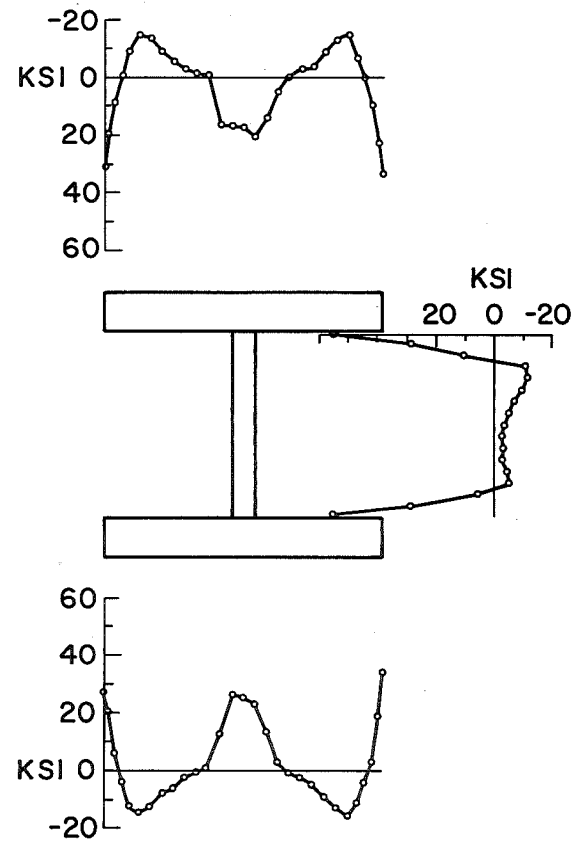

(c) FINAL RESIDUAL STRESSES

Fig. 20 Formation of Residual Stresses in a Heavy Welded Shape 23H681

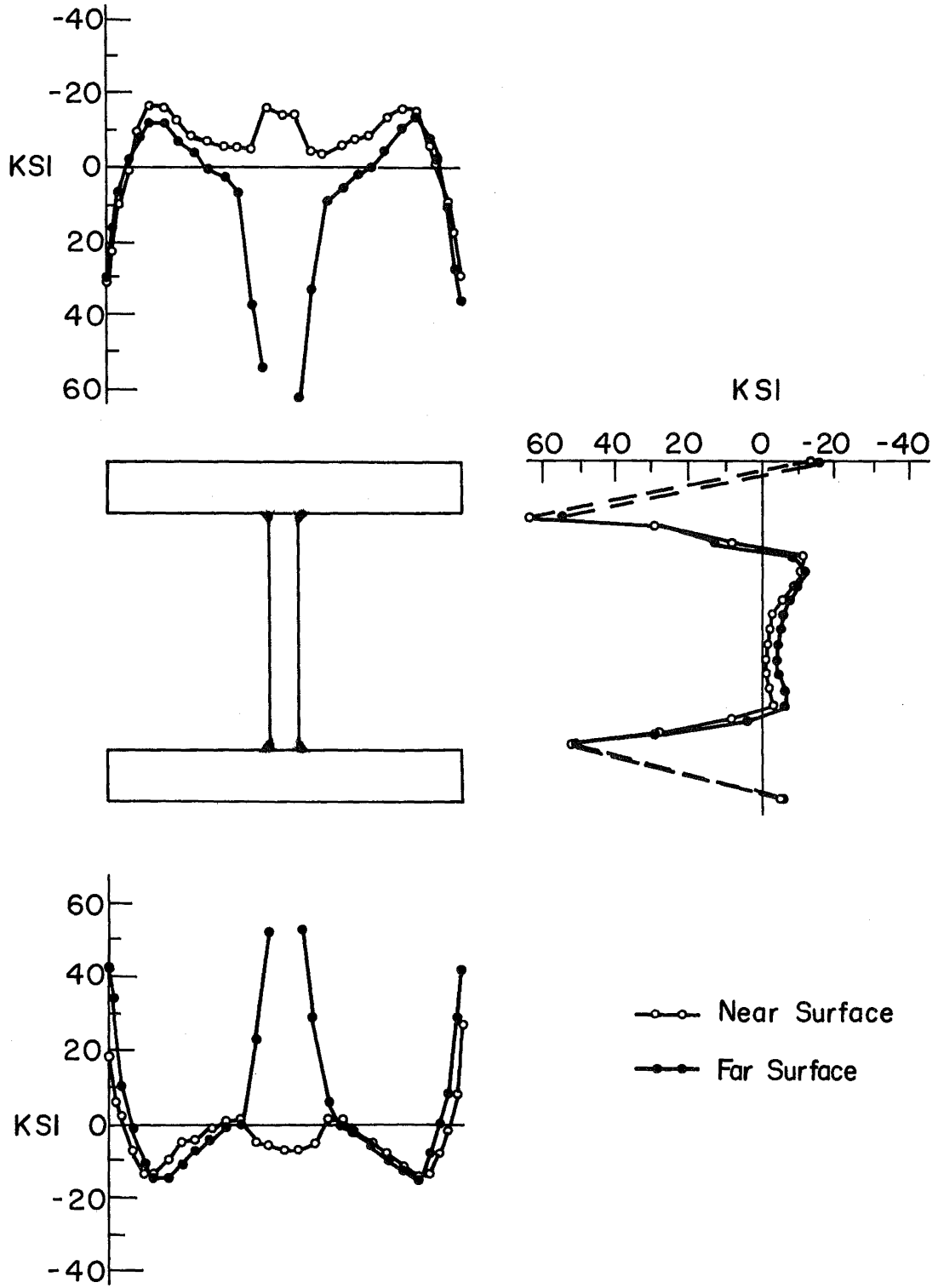

Fig. 21 Residual Stresses in a Welded Shape 23H681.
Flame-Cut Plates, A36 Steel, 1/2" Fillet Welds.

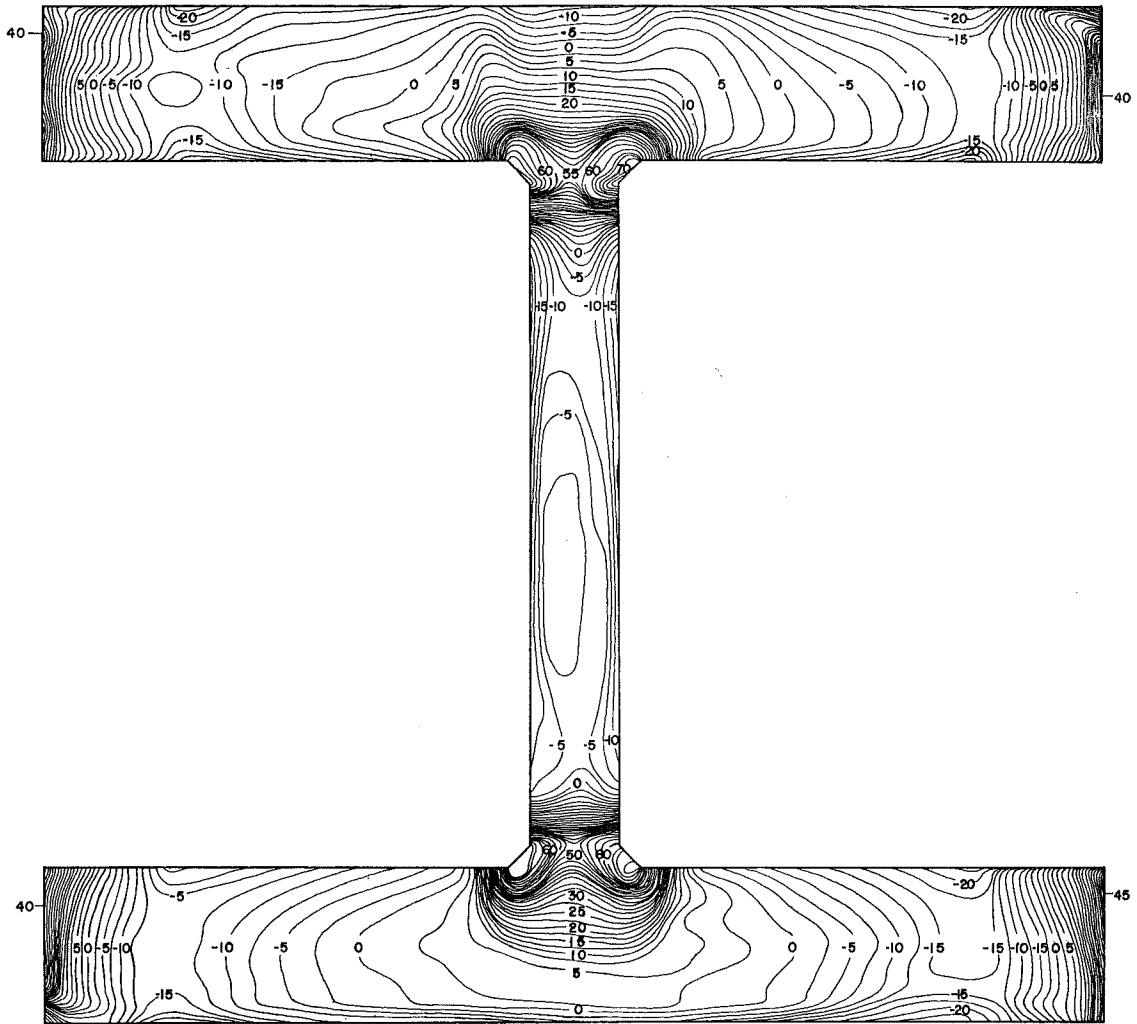

Fig. 22 Two-Dimensional Variation of Residual Stress in a Welded Shape 23H681. Flame-Cut Plates, A36 Steel, 1/2" Fillet Welds.

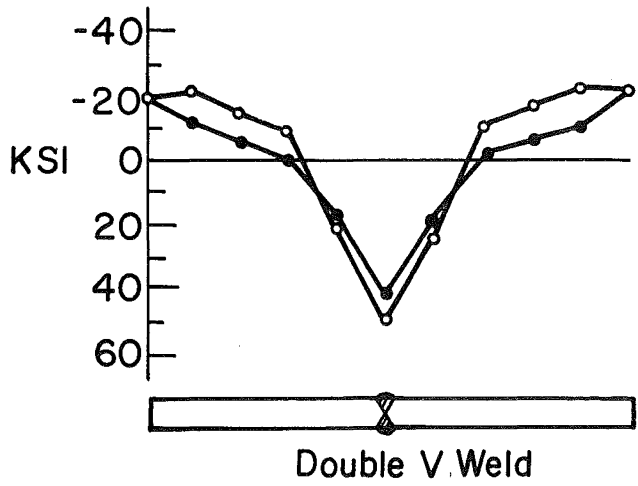
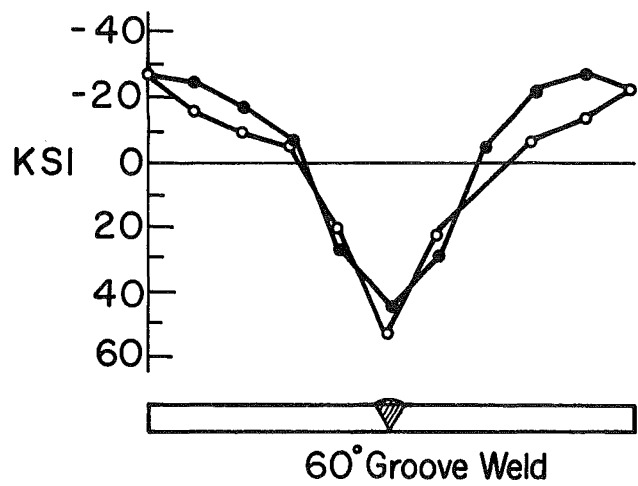
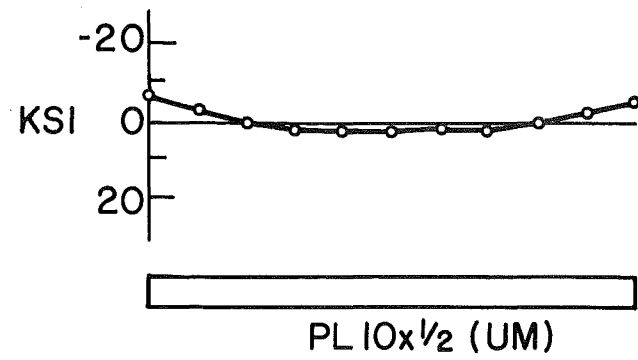

Fig. 23 Residual Stresses in a Universal-Mill Plate 10" x 1/2"

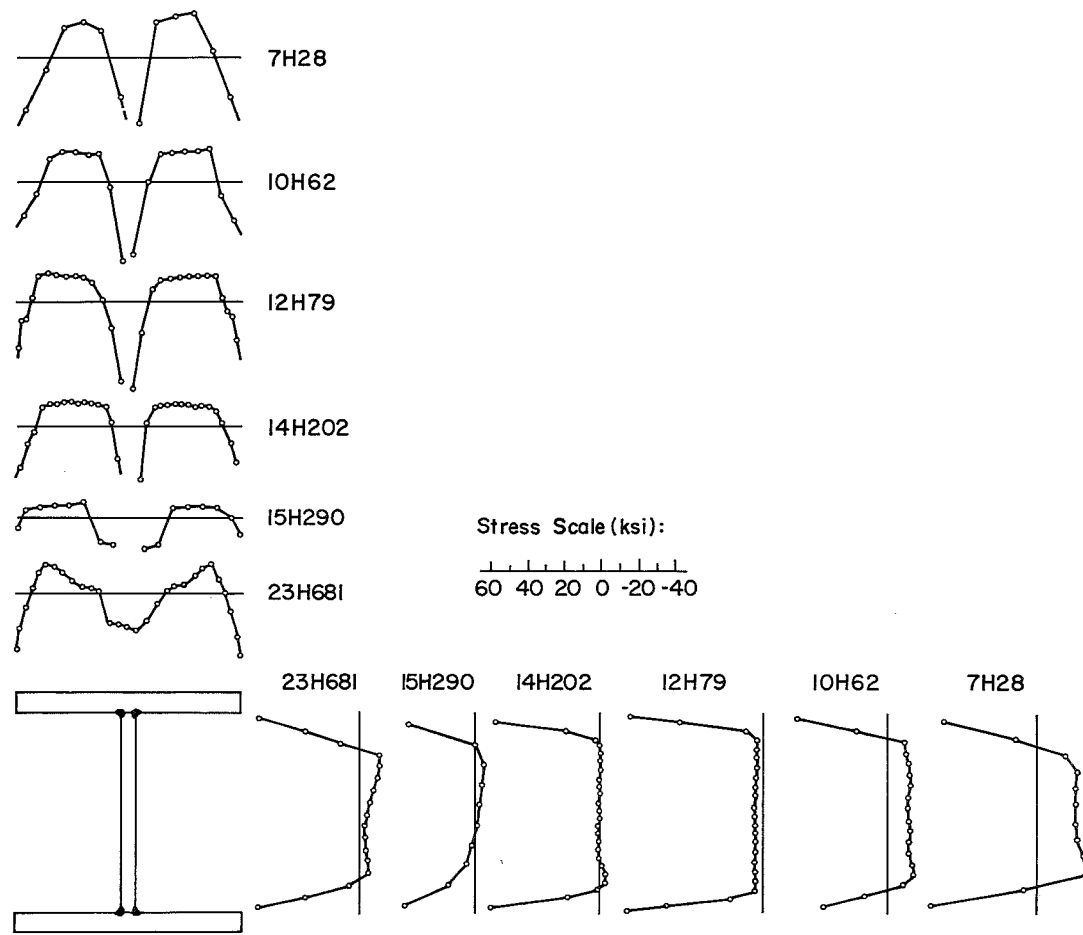

Fig. 24 Residual Stresses in Welded H-Shapes of Different Geometry. Flame-Cut Plates, A36 Steel, Fillet Welds. (Results for 12H79 and 14H202 Shapes from Ref. 15)

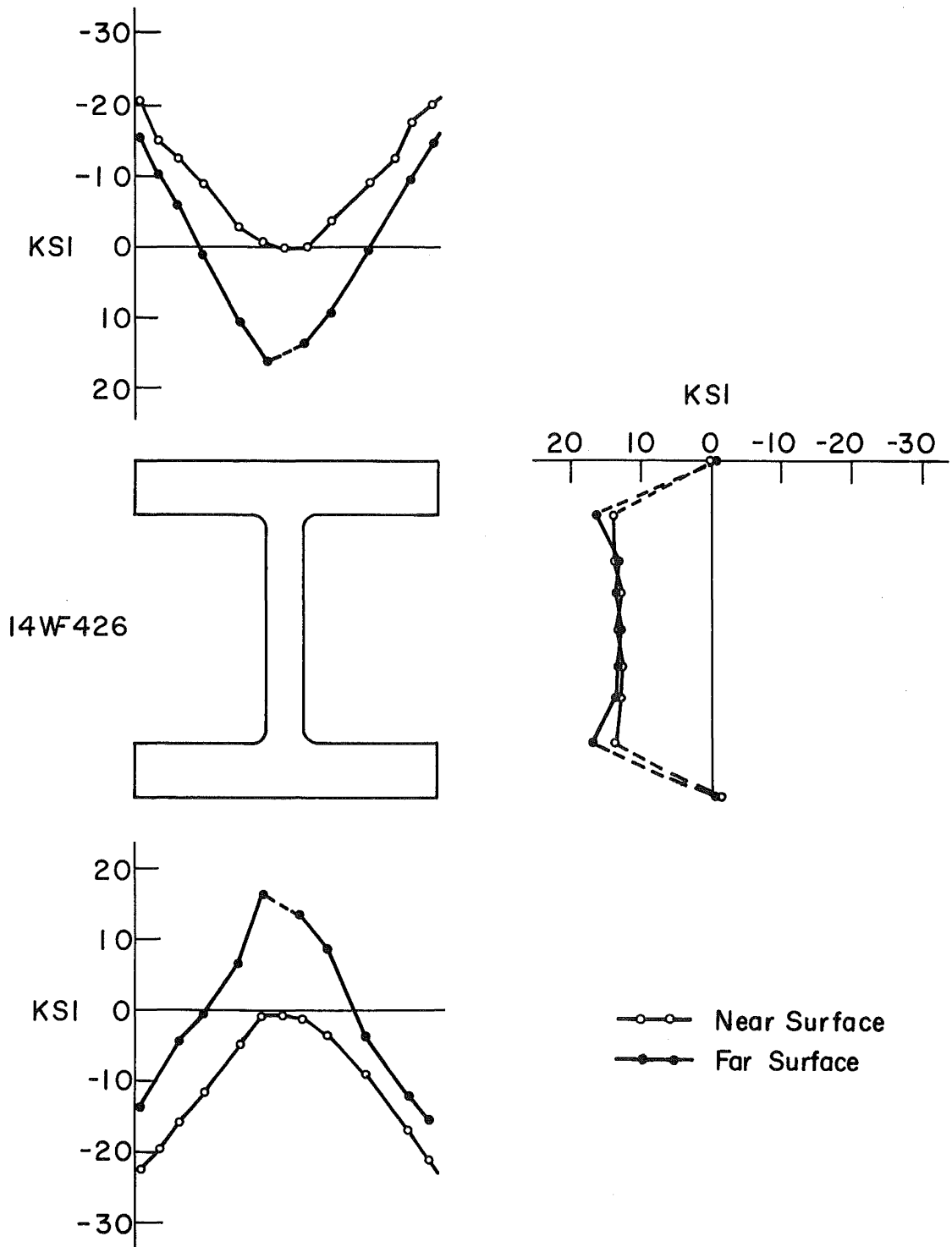

Fig. 25 Residual Stresses in a Hot-Rolled Shape 14WF426, A7 Steel

REFERENCES

1. A. W. Huber, and L. S. Beedle
RESIDUAL STRESSES AND THE COMPRESSIVE
PROPERTIES OF STEEL, Welding Journal, Vol. 33,
pp. 589-s to 614-s , 1954.
2. L. S. Beedle, and L. Tall
BASIC COLUMN STRENGTH, Trans. ASCE, Vol. 127,
Part II, pp. 138 to 179, 1962.
3. F. Nishino, Y. Ueda, and L. Tall
EXPERIMENTAL INVESTIGATION OF THE BUCKLING
OF PLATES WITH RESIDUAL STRESSES, ASTM STP No. 419,
"Test Methods for Compression Testing," August 1967.
4. Y. Ueda, and L. Tall
INELASTIC BUCKLING OF PLATES WITH
RESIDUAL STRESSES, Publications, International
Association for Bridge and Structural Engineering,
Vol. 27, 1967.
5. N. R. NagarajaRao, and L. Tall
RESIDUAL STRESSES IN WELDED PLATES,
Welding Journal, Vol. 40, pp. 468-s to 480-s, 1961.
6. F. R. Estuar, and L. Tall
EXPERIMENTAL INVESTIGATION OF BUILT-UP COLUMNS,
Welding Journal, Vol. 42(4), pp. 164-s to 176-s, 1963.
7. N. R. NagarajaRao, F. R. Estuar, and L. Tall
RESIDUAL STRESSES IN WELDED SHAPES,
Welding Journal, Vol. 43(7), pp. 295-s to 306-s, 1964.
8. G. A. Alpsten
RESIDUAL STRESSES IN A HEAVY WELDED SHAPE
23H681, Fritz Laboratory Report No. 337.9, In
Preparation.
9. G. A. Alpsten
THREE-DIMENSIONAL RESIDUAL STRESSES AND COLUMN
STRENGTH, Fritz Laboratory Report No. 337.20 ,
In Preparation.

10. N. Kalakoutsky
THE STUDY OF INTERNAL STRESSES IN CAST
IRON AND STEEL, London, 1888.
11. F. R. Estuar
WELDING RESIDUAL STRESSES AND THE STRENGTH
OF HEAVY COLUMN SHAPES, Ph.D. Dissertation,
Lehigh University, Aug. 1966. (University
Microfilms, Inc., Ann Arbor, Michigan).
12. J. Brozzetti, and G. A. Alpsten
ACCURACY OF THE SECTIONING METHOD FOR
RESIDUAL STRESS MEASUREMENTS, Fritz
Laboratory Report No. 337.11, in
Preparation.
13. G. A. Alpsten
THERMAL RESIDUAL STRESSES IN HOT-ROLLED
STEEL MEMBERS, Fritz Laboratory Report
No. 337.3, December, 1968.
14. Y. Kishima, G. A. Alpsten, and L. Tall
COLUMN STRENGTH OF WELDED SHAPES USING
FLAME-CUT PLATES, Fritz Laboratory
Report No. 321.4, In Preparation.
15. R. K. McFalls, and L. Tall
A STUDY OF WELDED COLUMNS MANUFACTURED FROM
FLAME-CUT PLATES, Fritz Laboratory Report
No. 321.1, June 1967.
16. G. A. Alpsten, and L. Tall
COLUMN STRENGTH OF HEAVY SHAPES - A
PROGRESS REPORT, Fritz Laboratory Report
No. 337.16, In Preparation.
17. Y. Fujita
THE MAGNITUDE AND DISTRIBUTION OF RESIDUAL
STRESSES, Fritz Laboratory Report No.
220A.20, May, 1955.