

## Lehigh University Lehigh Preserve

---

Fritz Laboratory Reports

Civil and Environmental Engineering

---

1973

# Preliminary proposal for tests of steel beam-to-column web connections, June 1973

G.P. Rentschler

W.F. Chen

Follow this and additional works at: <http://preserve.lehigh.edu/engr-civil-environmental-fritz-lab-reports>

---

### Recommended Citation

Rentschler, G.P. and Chen, W.F., "Preliminary proposal for tests of steel beam-to-column web connections, June 1973" (1973). *Fritz Laboratory Reports*. Paper 314.  
<http://preserve.lehigh.edu/engr-civil-environmental-fritz-lab-reports/314>

This Technical Report is brought to you for free and open access by the Civil and Environmental Engineering at Lehigh Preserve. It has been accepted for inclusion in Fritz Laboratory Reports by an authorized administrator of Lehigh Preserve. For more information, please contact [preserve@lehigh.edu](mailto:preserve@lehigh.edu).

333.24

Beam-to-Column Connections

PRELIMINARY PROPOSAL FOR TESTS OF  
STEEL BEAM-TO-COLUMN WEB CONNECTIONS

by

Glenn P. Rentschler

and

Wai-Fah Chen

FRITZ ENGINEERING  
LABORATORY LIBRARY

This work has been carried out as part of an investigation sponsored jointly by the American Iron and Steel Institute and the Welding Research Council.

Department of Civil Engineering

Fritz Engineering Laboratory

Lehigh University

Bethlehem, Pennsylvania

June 1973

Fritz Engineering Laboratory Report No. 333.24

TABLE OF CONTENTS

	<u>Page</u>
1. INTRODUCTION	1
2. GENERAL COMMENTS	3
3. TABLE OF WEB CONNECTIONS	6
4. REFERENCES	19
APPENDIX 1	20

## 1. INTRODUCTION

In the priority sequence for beam-to-column connection research suggested by the members of the WRC Task Group and specified in Ref. 1, July 1972, future connection research was classified in five priority groups.

Research work included within priority Group A is detailed in Ref. 2. Within Group A are Phases 10 and 11, which constitute the major work of this group. Phase 10 is entitled "Flange Welded Web Bolted Connections" and Phase 11 is "Bolted Top and Bottom Plate Connections", both dealing with symmetric moment connections. Of the twelve specimens fabricated for testing in this group, to date eight have been tested. The results of these tests have been periodically presented to the WRC Task Group and currently, one doctoral dissertation presenting the results of these tests has been completed.

With the work of priority Group A being substantially complete, attention was shifted to Group B. Of the two topics in Group B, Beam-to-column web connections was chosen as the next research activity. This topic is considered as Problem 2.1 and classified as Phase 14 in Ref. 1.

Phase 14 can be considered an extension of Phases 10 and 11. However, in Phase 14 the reactions of the beam on the column will tend to bend the column about the weak axis rather than the strong axis action of Phases 10 and 11. Also, in Phase 14 the connections will not be treated to be loaded symmetrically because in actual building frames, web connections often occur at corners or on the outer column line where symmetry does not exist.

The objective of the web connection test program is to find the web connection(s) which satisfy the below listed criteria:

1. strength
2. stiffness
3. ductility
4. economy of fabrication

This report may be considered to be the preliminary test program for beam-to-column web connections. The twelve web moment connections shown on the following pages are typical connections used frequently in building construction. Below each connection are listed a series of options which may be used to modify the particular connection. It will not be the purpose of the web connection research program to test all twelve connections, but rather to fabricate and test the one or two most common and feasible connections and possibly apply a finite element analysis to investigate the behavior of many of the other connections. This procedure was adopted following the realization of the tremendous expense involved in fabricating and testing the twelve specimens of Phases 10 and 11.

The following section on "General Comments" lists many of the assumptions and guidelines to be used in the design, fabrication, and testing aspects of the web connection test program. Many of these (e.g., High Strength Bolts, Slotted holes,  $F_y = 55$  ksi steel, and section sizes) are the same criteria which were used in Phases 10 and 11.

## 2. GENERAL COMMENTS

1. Specimens will be made of ASTM A572 Grade 55 steel. This steel was selected because it has the least ductility of a high strength high use steel.
2. Beam flanges will be assumed to resist all bending moment.  
(Based on results of Phases 10 and 11)
3. Beam web will be assumed to carry total shear. (Based on results of Phases 10 and 11)
4. Both ASTM A325 and A490 High Strength Bolts will be used with basic allowable shear stresses of 30 ksi and 40 ksi respectively. These basic allowables will be modified for friction-type connections depending on surface preparation and allowable slip. These allowable stresses are based on satisfactory performance in Phases 10 and 11)
5. Oversize holes will be used in friction-type connections.
6. Long slotted holes will be used in bearing-type web connections.
7. Long slotted holes will be used where erection bolts are used.
8. Both A325 and A490 bolts will be installed by the turn-of-nut method.
9. The connection specimens will be welded according to AWS Building Code using E70TG low hydrogen electrodes. Orthosonic inspection of groove welds will be made.
10. The connection will be loaded monotonically up to failure. There is no strain reversal at any location in the beam.
11. Two different combinations of beams and columns will be considered.

Combination I: Simulates lower stories of a building

Beam: W27x94,  $A = 27.7$ ,  $d = 26.91$ ,  $b_f = 9.90$ ,  $t_f = 0.747$ ,

$$t_w = 0.490, I_x = 3270, \frac{d}{A_f} = 3.61$$

Column: W14x176,  $A = 51.7$ ,  $d = 15.25$ ,  $b_f = 15.64$ ,  $t_f = 1.313$ ,

$$t_w = 0.820, I_x = 2150, I_y = 838, \frac{d}{A_f} = 0.743, d - 2k = 11\frac{1}{4}$$

This was the same combination as used in Phases 10 and 11.

Combination II: Simulates upper stories of a building

Beam: W16x31,  $A = 9.13$ ,  $d = 15.84$ ,  $b_f = 5.525$ ,  $t_f = 0.442$ ,

$$t_w = 0.275, I_x = 374, \frac{d}{A_f} = 6.49$$

Column: W10x60,  $A = 17.7$ ,  $d = 10.25$ ,  $b_f = 10.075$ ,  $t_f = 0.683$ ,

$$t_w = 0.415, I_x = 344, I_y = 116, \frac{d}{A_f} = 1.49, d - 2k = 7\frac{3}{4}$$

12. Three test set-ups have been suggested. Set-up 1 tests the connection under unsymmetrical loading with moderate column axial force. This set-up would be used if it was anticipated that column axial force has a significant effect on connection behavior. It must also be pointed out that this is an expensive testing set-up. Set-up 2 tests the connection symmetrically and Set-up 3 tests unsymmetrically, both at insignificant amounts of axial load on the column. It was found in the strong axis bending of columns in Phases 10 and 11 that axial force had only a very small effect on connection performance. It also appears that this will be the case for beam-to-column web connections. Thus, if column axial force is of no concern, Set-up 3 is the most economical and most convenient testing procedure to test the connection unsymmetrically. Set-up 2 may be used if it is desired to test symmetrical loading, such as would occur at an interior column of a building.

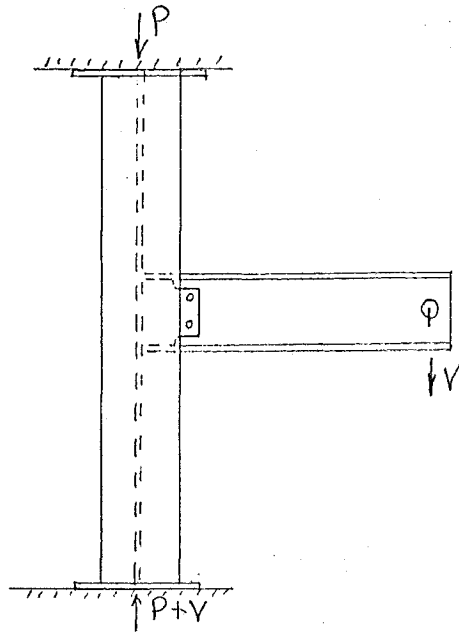

Set-Up 1

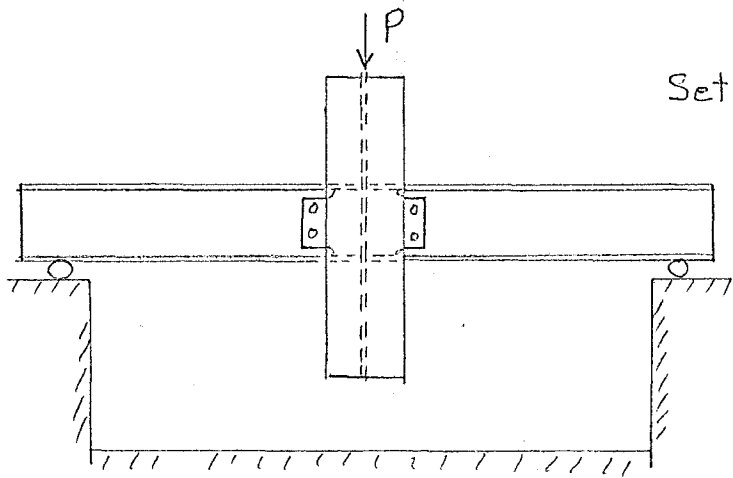

Set-Up 2

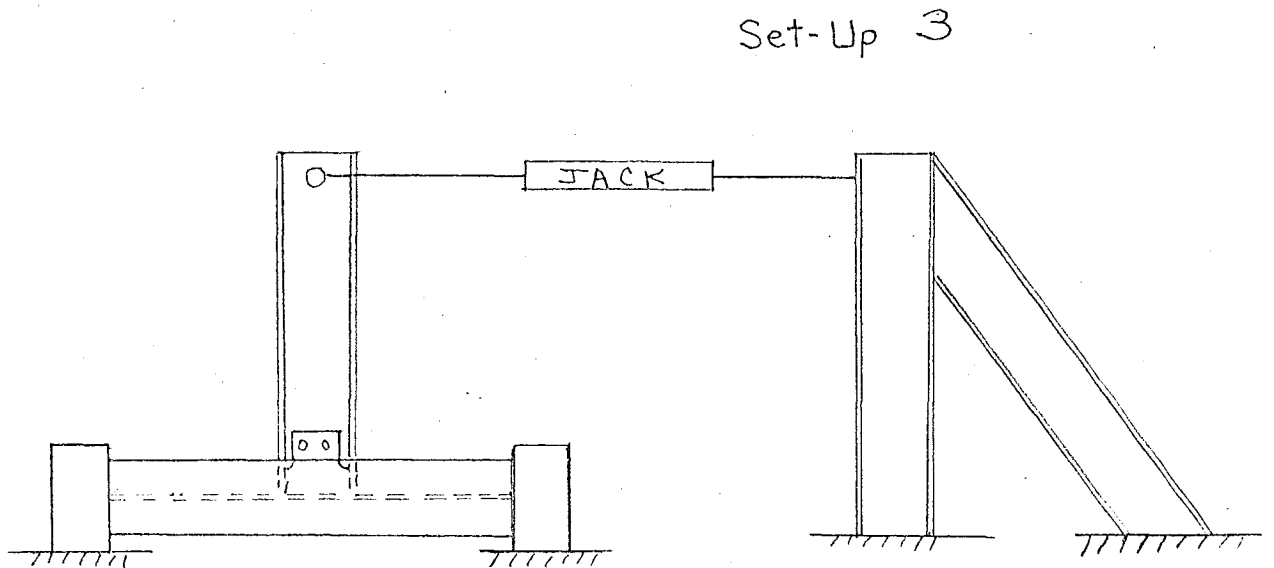

Set-Up 3

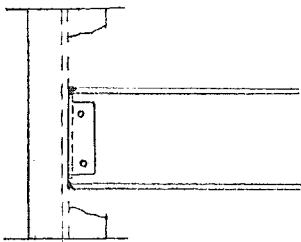
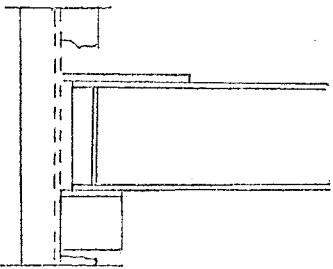
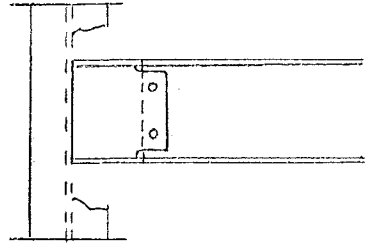
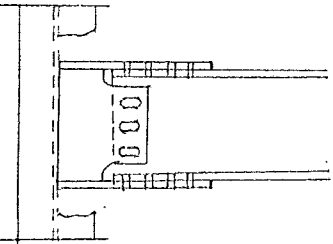
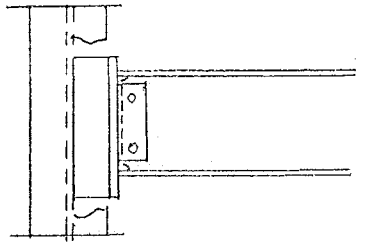
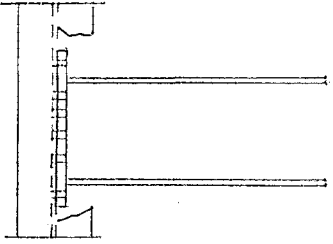
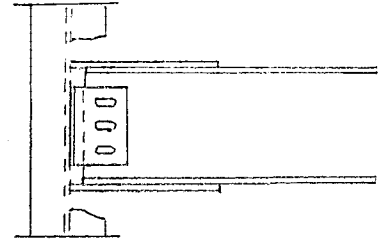
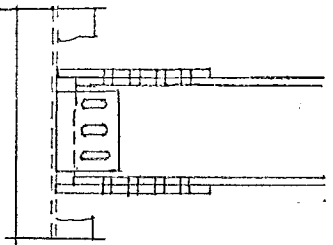
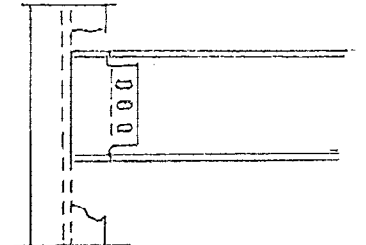
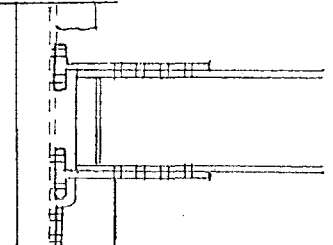
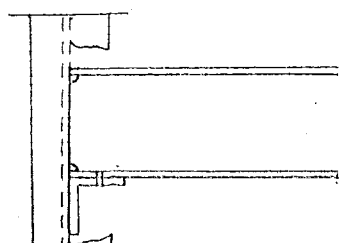
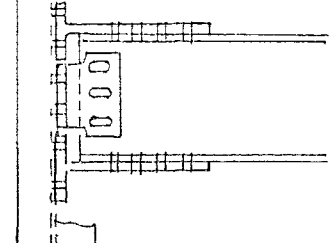

3. TABLE OF WEB CONNECTIONS

1		7	
2		8	
3		9	
4		10	
5		11	
6		12	

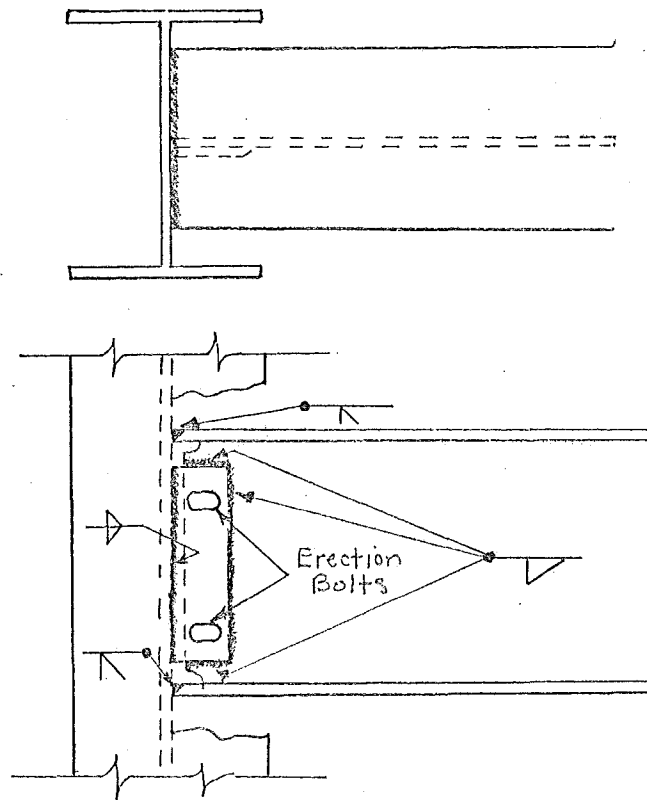
CONNECTION 1 (Ref. 3)OPTIONS

1. Add stiffeners
  - a. fillet weld only to column flanges
  - b. fillet weld only to column
  - c. fillet weld to both column web and flanges
2. If beam flange is wider than  $d-2k$  of column:
  - a. cut out beam flanges and groove weld beam flanges as shown
  - b. cut out beam flanges and fillet weld beam flange to column web and groove weld beam flanges to column flanges
3. Replace flange groove welds by fillet welds
4. Groove weld beam web directly to column web using the web connection plate as a back-up plate. Omit fillet weld between web plate and beam web.

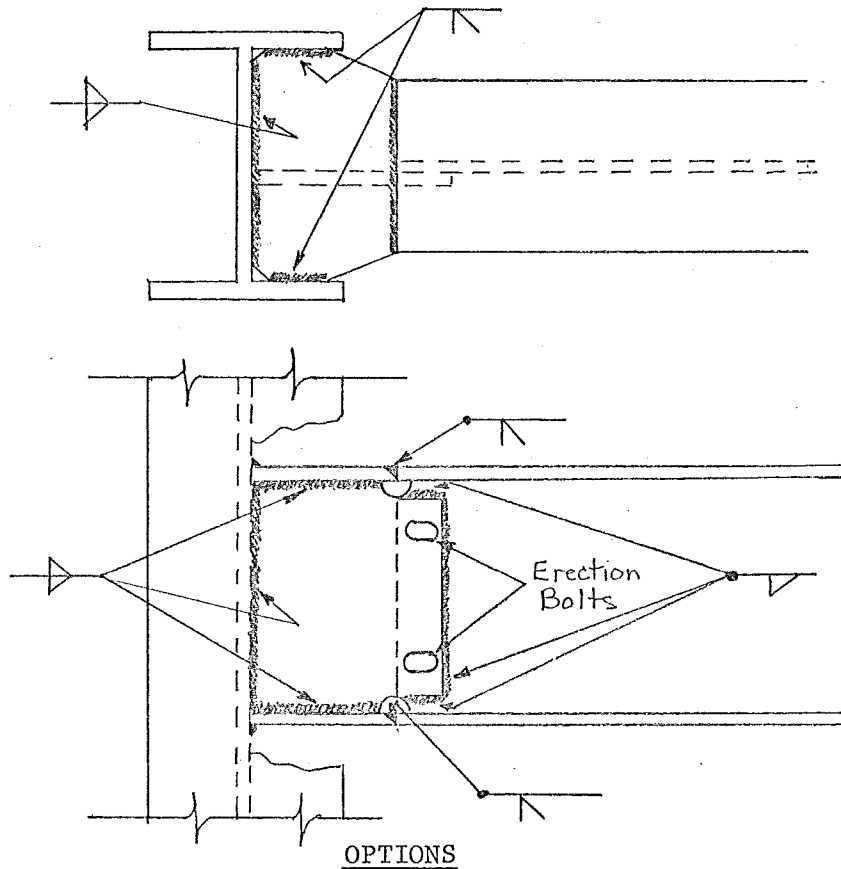
CONNECTION 2 (Ref. 7)

1. Add stiffeners
  - a. fillet weld only to column flanges
  - b. fillet weld only to column web
  - c. fillet weld to both column web and flanges
2. Omit groove welds between top and bottom connection plates and column flanges
3. Omit groove welds between top and bottom connection plates and column flanges and groove weld connection plate to column web

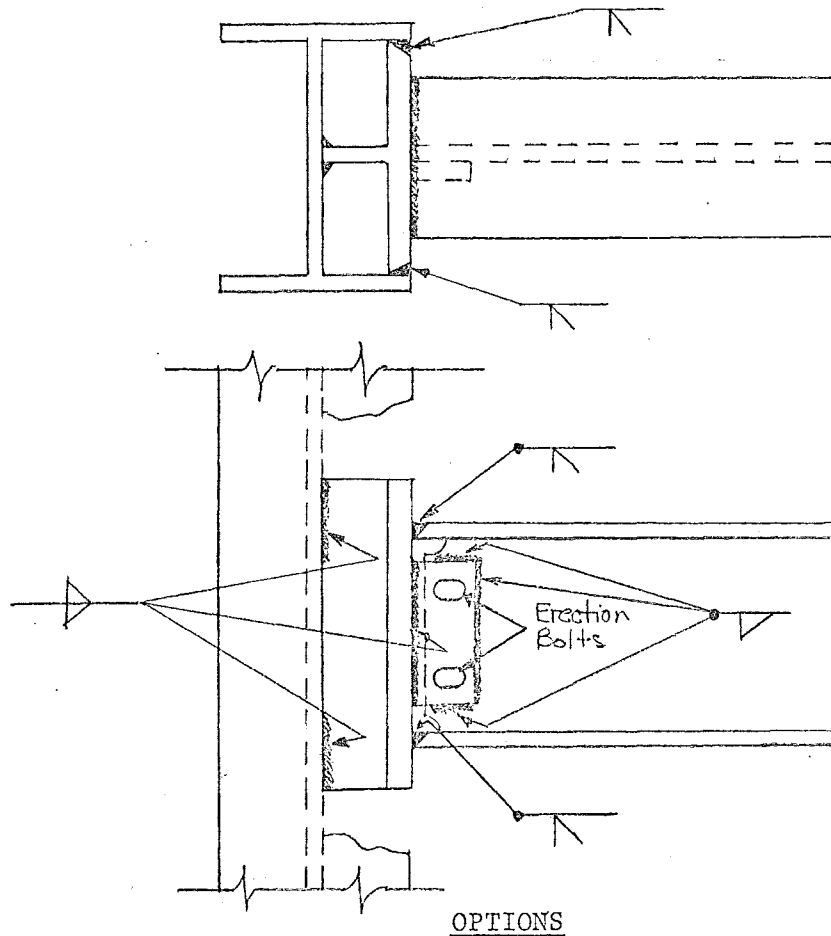
CONNECTION 3 (Ref. 5)

1. Use some form of stiffener on opposite side of column web. (Use T-Section similar to connection plate.)
2. Groove weld beam web directly to connection plate (T-Section) using the web connection plate as a back-up plate. Omit fillet welds between web plate and beam web.
3. Replace flange groove welds by fillet welds.
4. Replace groove welds joining T-Section to column flanges by fillet welds.

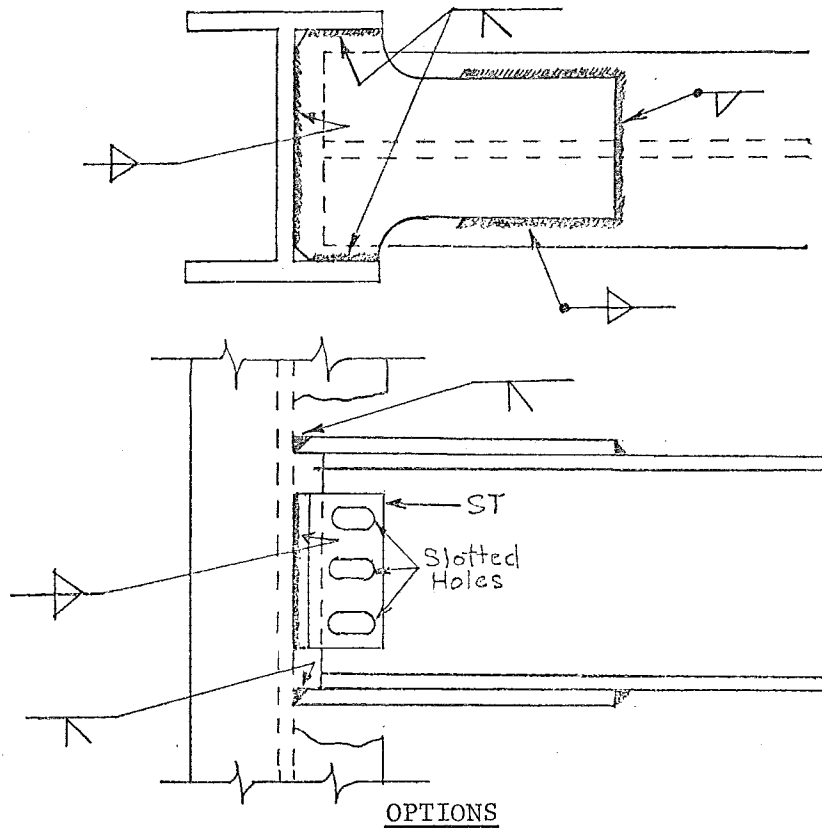
CONNECTION 4 (Ref. 3)

1. Add stiffeners.
  - a. fillet weld only to column flanges
  - b. fillet weld only to column web
  - c. fillet weld to both column web and flanges
2. Omit groove welds between connection plate and column flanges.
3. Omit groove welds between connection plate and column flanges and groove weld connection plate to column web.
4. Use Angle or Double Angle rather than Structural Tee.
5. Use regular round holes instead of slotted holes.

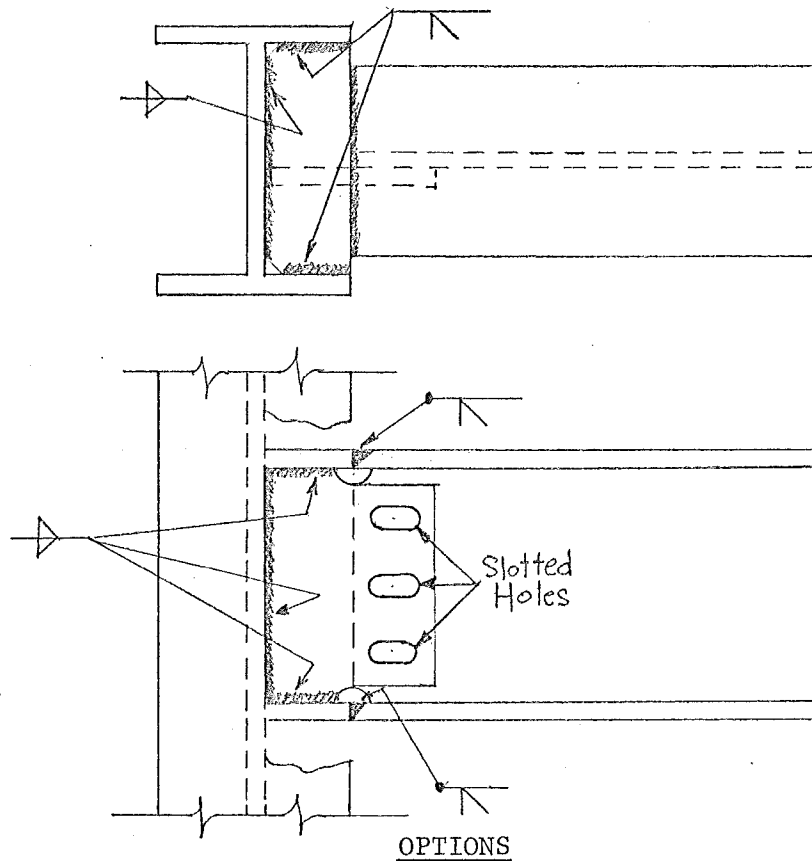
CONNECTION 5 (Ref. 6)

1. Add stiffeners.
  - a. fillet weld only to column flange
  - b. fillet weld only to column web
  - c. fillet weld to both column web and flanges
2. Omit groove welds between top and bottom connection plates and column flanges
3. Omit groove welds between top and bottom connection plates and column flanges and groove weld connection plate to column web.
4. Use regular round holes instead of slotted holes.

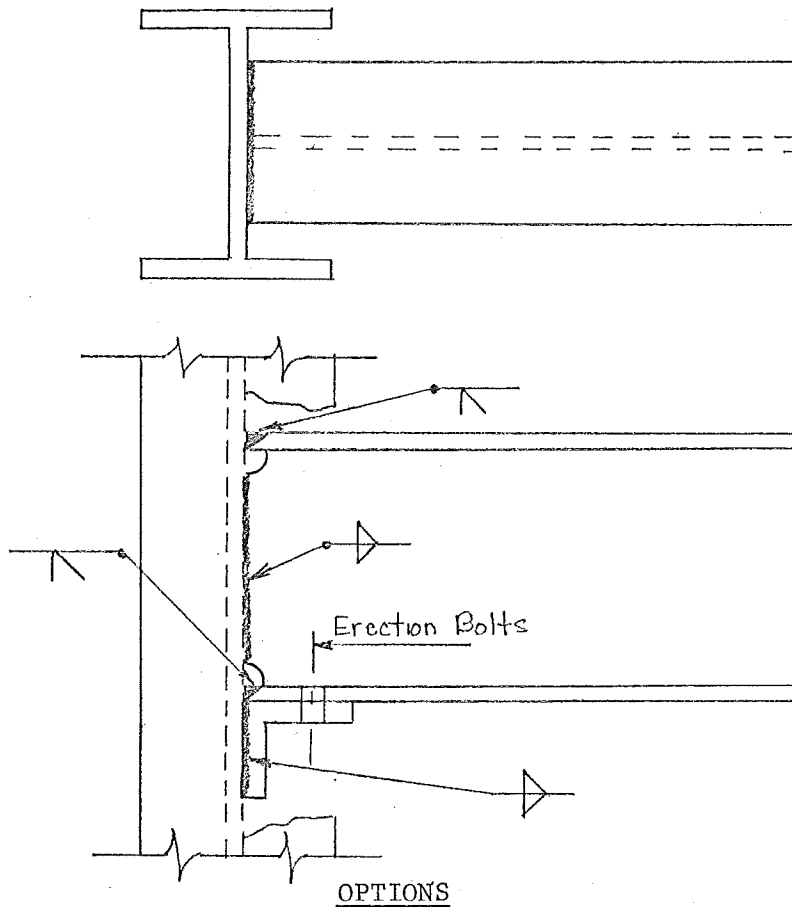
CONNECTION 6 (Ref.3)

1. Add stiffener opposite top flange.
  - a. fillet weld only to column flanges
  - b. fillet weld only to column web
  - c. fillet weld to both column web and flanges
2. If beam flange is wider than  $d-2k$  of column:
  - a. cut out beam flanges and groove weld as shown
  - b. cut out beam flanges and fillet weld beam flanges to column web and groove weld beam flanges to column flanges
3. Replace flange groove welds with fillet welds.
4. Groove weld beam web to column web.

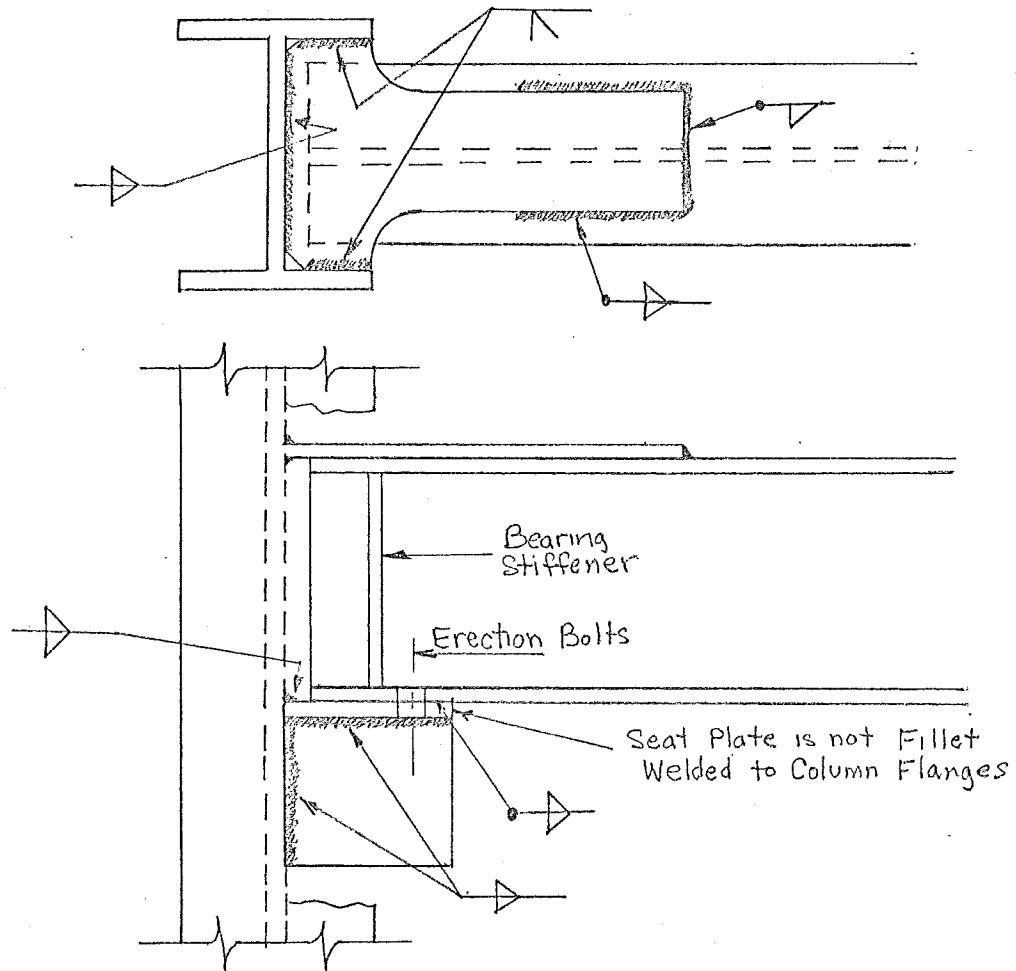
OPTIONS

1. Add stiffener opposite top flange.
  - a. fillet weld only to column flanges
  - b. fillet weld only to column web
  - c. fillet weld to both column web and flanges
2. Omit groove welds between top connection plates and column flanges.
3. Omit groove welds between top connection plates and column flanges and groove weld top connection plate to column web.
4. Groove weld seat plate to column flanges.
5. Use Structural Tee rather than welding two separate plates.
6. Omit bearing stiffener.

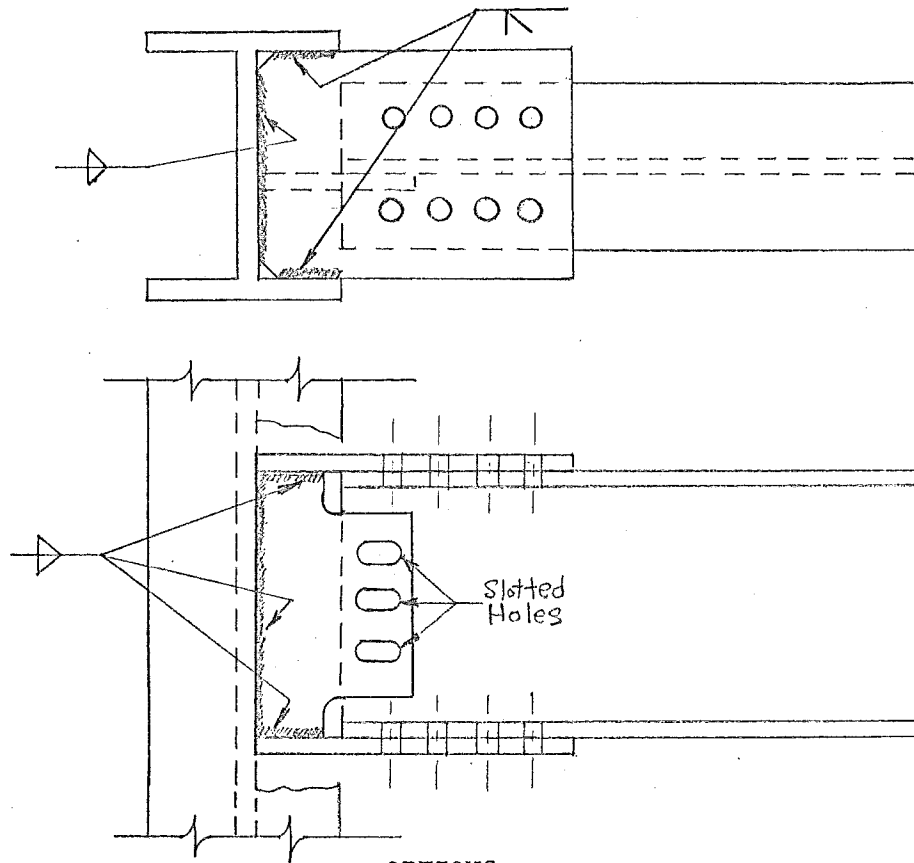

CONNECTION 8 (Ref. 4)OPTIONS

1. Add stiffeners.
  - a. fillet weld only to column flanges
  - b. fillet weld only to column web
  - c. fillet weld to both column web and flanges
2. Omit groove welds between top and bottom connection plates and column flanges.
3. Omit groove welds between top and bottom connection plates and column flanges and groove weld connection plate to column web.
4. Use round holes, 1/16 in. larger than nominal bolt diameter, instead of slotted web holes.
5. Use oversize holes in flange connections for friction connections.  
Use round holes 1/16 in. in excess of nominal bolt diameter for bearing connections.

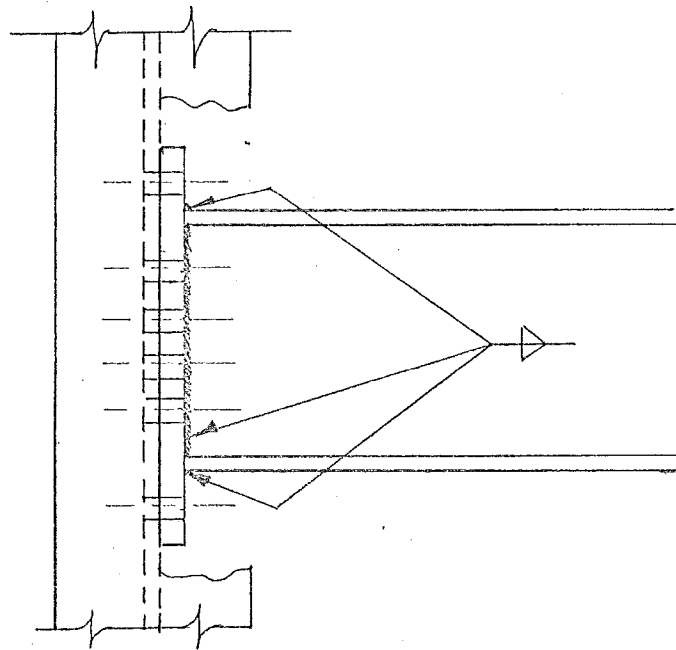
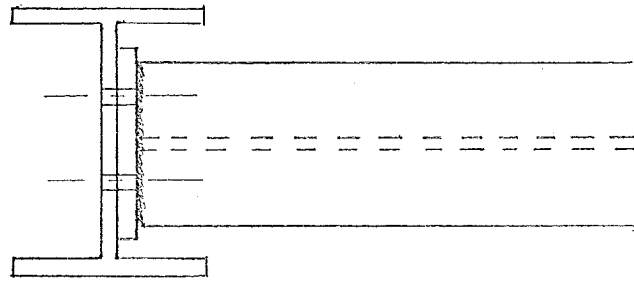
CONNECTION 9 (Ref. 3)OPTIONS

1. Add stiffeners.
  - a. fillet weld only to column flanges
  - b. fillet weld only to column web
  - c. fillet weld to both column web and flanges
2. If beam flange is wider than  $d-2k$  of column, cut out beam flange to fit.
3. Omit fillet welds between beam flanges and connection plate and replace by groove welds.

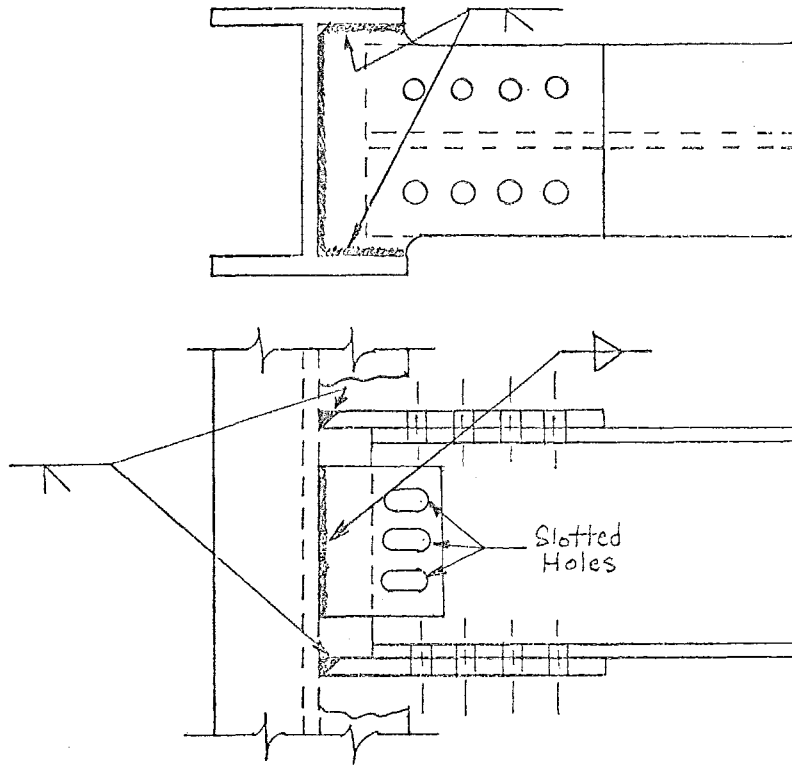
CONNECTION 10 (Ref. 3)OPTIONS

1. Add stiffeners.
  - a. fillet weld only to column flanges
  - b. fillet weld only to column web
  - c. fillet weld to both column web and flanges
2. Omit groove welds between top and bottom connection plates and column flanges.
3. Omit groove welds between top and bottom connection plates and column flanges and fillet weld connection plates to column web.
4. Use round holes, 1/16 in. larger than nominal bolt diameter, instead of slotted web holes.
5. Use oversize holes in flange connections for friction connections. Use round holes 1/16 in. in excess of nominal bolt diameter for bearing connections.
6. Use groove rather than fillet weld for web plate.
7. Use Structural Tee for web connection.

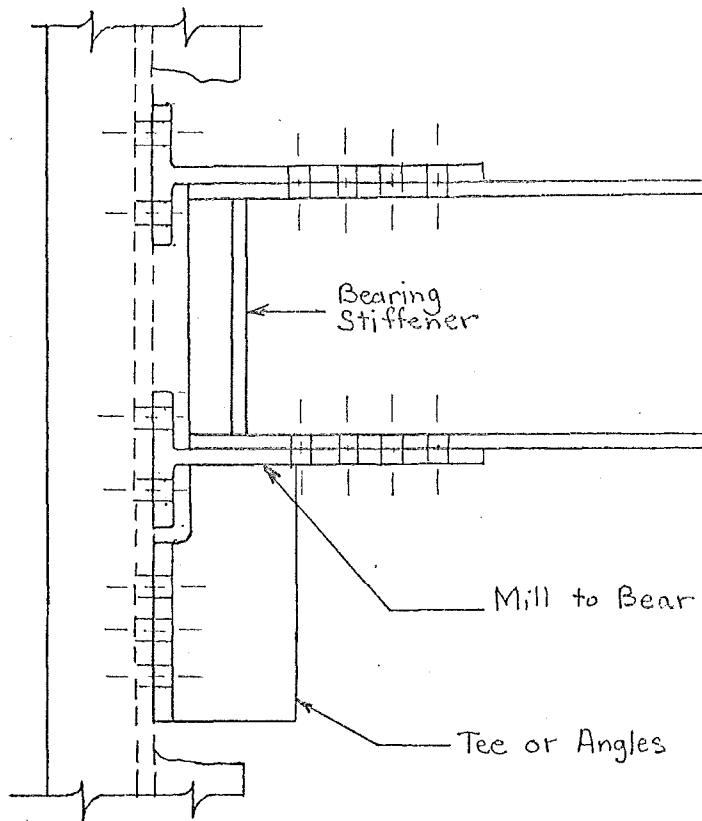
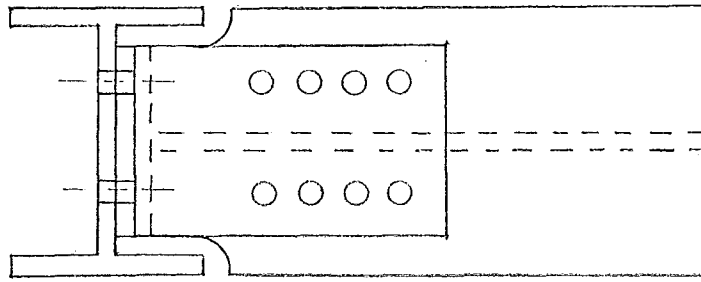
CONNECTION II (Ref.4)OPTIONS

1. Add stiffeners.
  - a. fillet weld only to column flanges
  - b. fillet weld only to column web
  - c. fillet weld to both column web and flanges
2. Omit stiffeners.
3. Use oversize holes in flange connections for friction connections.  
Use round holes 1/16 in. in excess of nominal bolt diameter for bearing connections.

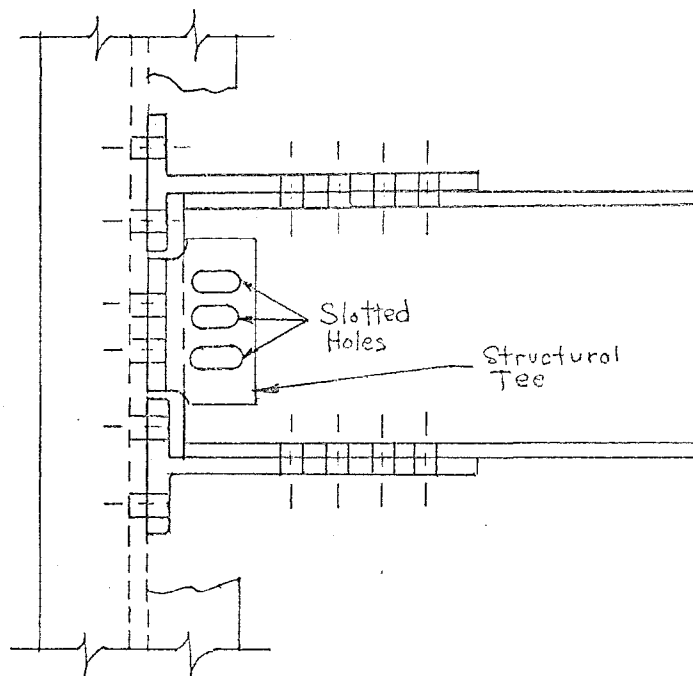
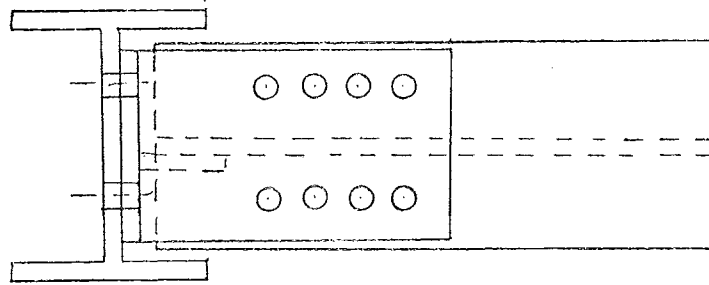
CONNECTION 12 (Ref. 3)OPTIONS

1. Add stiffeners.
  - a. fillet weld only to column flanges
  - b. fillet weld only to column web
  - c. fillet weld to both column web and flanges
2. Use oversize holes in flange connections for friction connections.  
Use round holes 1/16 in. in excess of nominal bolt diameter for bearing connections.
3. Use round holes, 1/16 in. larger than nominal bolt diameter, instead of slotted web holes.
4. Use angles for web connection rather than Structural Tee.

4. REFERENCES

1. Huang, J. S., Fielding, D. J., Chen, W. F. and Staff  
FUTURE CONNECTION RESEARCH PROBLEMS, Fritz Laboratory Report  
333.7, Lehigh University, Bethlehem, Pa., July 1972.
2. Huang, J. S., Chen, W. F. and Regec, J. E.  
TEST PROGRAM OF STEEL BEAM-TO-COLUMN CONNECTIONS, Fritz  
Laboratory Report 333.15, Lehigh University, Bethlehem, Pa.,  
July 1971.
3. AISC  
STRUCTURAL STEEL DETAILING, 2nd Edition, American Institute  
of Steel Construction, New York, New York, October 1971.
4. AISC  
MANUAL OF STEEL CONSTRUCTION, 7th Edition, American Institute  
of Steel Construction, New York, New York, 1970.
5. Blodgett, O. W.  
DESIGN OF WELDED STRUCTURES, The James F. Lincoln Arc Welding  
Foundation, Cleveland, Ohio, 1966.
6. Gaylord, E. H. and Gaylord, C. N.  
STRUCTURAL ENGINEERING HANDBOOK, McGraw-Hill Book Co., New  
York, 1968.
7. Popov, E. P. and Pinkney, R. B.  
CYCLIC YIELD REVERSAL IN STEEL BUILDING CONNECTIONS, ASCE  
Journal of the Structural Division, Vol. 95 (ST3), March 1969.

APPENDIX 1 CURRENT PROGRAM: BEAM-TO-COLUMN CONNECTIONS

Phases:

1. Pilot tests on small welded (stiffened) connections cut from old test frames. (complete) 333.2
2. Theoretical analysis of column load-moment interaction. (deferred)
3. Study of U.S., Japanese, and British test data on beam-to-column connections. (complete) 333.7
4. Preparation of design table for connection shear stiffening requirements using results of (2) above. (deferred)
5. Major test on a large connection with no shear stiffening. (complete) 333.9
6. Analysis of effect on structure of omitting shear stiffening. (current) 333.16
7. Tests to check column web buckling formula especially for higher strength steels. (complete) 333.10, 333.14
8. Study of stiffening requirements for beams of different depth on opposite sides of interior connection. (deferred)
9. Basic study of plastic deformation and strain hardening in a thick plate subject to high shear stress. (deferred)
10. Flange-welded web-bolted connections. (current) 333.15, 333.17
11. Bolted top and bottom plate connections. (current) 333.15, 333.17
12. Study of web stiffeners. (current)
13. Study of connection behavior in related tests. (current)
14. Beam-to-column web connections. (future)
15. Panel zone stiffening by adding a web doubler plate for beam-to-column flange connections. (future)