

1968

# Gas removal system part iii : model study, February 1969

J.B. Herbich

J. R. Adams

S. C. Ko

Follow this and additional works at: <http://preserve.lehigh.edu/engr-civil-environmental-fritz-lab-reports>

---

## Recommended Citation

Herbich, J.B.; Adams, J. R.; and Ko, S. C., "Gas removal system part iii : model study, February 1969" (1968). *Fritz Laboratory Reports*. Paper 223.

<http://preserve.lehigh.edu/engr-civil-environmental-fritz-lab-reports/223>

This Technical Report is brought to you for free and open access by the Civil and Environmental Engineering at Lehigh Preserve. It has been accepted for inclusion in Fritz Laboratory Reports by an authorized administrator of Lehigh Preserve. For more information, please contact [preserve@lehigh.edu](mailto:preserve@lehigh.edu).

310.21  
442.5



Dredge Pump Research

# GAS REMOVAL SYSTEM PART III: MODEL STUDY

FRITZ ENGINEERING  
LABORATORY LIBRARY

by  
J. B. Herbich  
J. R. Adams  
S. C. Ko

Fritz Engineering Laboratory Report No. 310.21

FRITZ ENGINEERING LABORATORY INSTITUTE OF RESEARCH

CIVIL ENGINEERING DEPARTMENT  
FRITZ ENGINEERING LABORATORY  
HYDRAULICS AND SANITARY ENGINEERING DIVISION

GAS REMOVAL SYSTEM  
PART III  
MODEL STUDY

Project Report No. 53

Prepared by  
J. B. Herbich  
J. R. Adams  
S. C. Ko

Prepared for  
U. S. Army Engineer District, Philadelphia  
Corps of Engineers  
Philadelphia, Pennsylvania

February 1969

Fritz Engineering Laboratory Report No. 310.21

## ABSTRACT

The results of Test Series No. 1 and No. 2, Phase C, of the study of gas removal systems for dredge pumps are presented. In addition, a brief study of the effect of gas injection methods is discussed.

Test Series No. 1 resulted in development of a criterion for the gas flow which can be tolerated in dredging. The effect of continuous gas flow on dredging performance was determined.

Test Series No. 2 indicated that the existing gas removal system is not effective when continuous gas flow is encountered. Control of accumulator vacuum was found to be difficult.

The air injection studies showed that the behavior of the gas flow is an important factor. Intermittent air slugs were partially removed, and generally caused only a momentary decrease in pump performance.

## PREFACE

The following project report summarizes the studies performed as part of Phase C of the project between February 1965 and October 1967. The project is being conducted in the Hydraulic and Sanitary Engineering Division of Fritz Engineering Laboratory, Department of Civil Engineering, Lehigh University, in accordance with Contract No. DA-36-109-CIVENG-64-72 for the Marine Design Division, Philadelphia District; U. S. Army Corps of Engineers. Progress on this phase of the project has been reported in eleven status reports dated June 1965, August 1965, August 1966, October 1966, December 1966, April 1967, and September 1967.

Phases A and B of the project were completed and summarized in Fritz Engineering Laboratory Report Nos. 310.3 (June 1964) and 310.7 (February 1965) respectively.

Dr. John R. Adams is the Project Director, and he is assisted by Mr. S. C. Ko, Research Instructor. Dr. John B. Herbich was Project Director prior to February 1967. Dr. Adnan Shindala, Mr. A. N. Amatangelo, Mr. G. Bagge, and Mr. R. E. Miller assisted in portions of the program. Dr. D. A. VanHorn is Chairman of the Civil Engineering Department and Dr. L. S. Beedle is Director of Fritz Engineering Laboratory.

## LIST OF CONTENTS

ABSTRACT

PREFACE

LIST OF FIGURES

1. INTRODUCTION
  - 1.1 Background
  - 1.2 Scope of Project
  - 1.3 Test Facility
  - 1.4 Results to Date
  - 1.5 Future Plans
2. EXPERIMENTAL STUDY PROGRAM
  - 2.1 Discussion
  - 2.2 Model-Prototype Relations
  - 2.3 Detailed Program
3. EXPERIMENTAL FACILITY
  - 3.1 Facility for Test Series No. 1
    - 3.1.1 Pump
    - 3.1.2 Impeller
    - 3.1.3 Pump Characteristics Without Air
    - 3.1.4 Motor
    - 3.1.5 Magnetic Flow Meter
    - 3.1.6 Pump Speed
    - 3.1.7 Air Compressor
    - 3.1.8 Air Injection
    - 3.1.9 Measuring Equipment
  - 3.2 Facility for Test Series No. 2
    - 3.2.1 Vacuum Receiver
    - 3.2.2 Vacuum Pump
    - 3.2.3 Vacuum Flow Meter
    - 3.2.4 Accumulator Fluid Level Controller
  - 3.3 Equipment for Air Injection Tests
4. EXPERIMENTAL STUDIES
  - 4.1 Introductory Comments
  - 4.2 Difficulties Encountered
    - 4.2.1 Installation Delays
    - 4.2.2 Experimental Difficulties
  - 4.3 Development of Air Flow Meter
  - 4.4 Experimental Procedures
  - 4.5 Visual Observations

5. EXPERIMENTAL RESULTS

- 5.1 Data Analysis
- 5.2 Test Series No. 1
- 5.3 Test Series No. 2
- 5.4 Air Injection Tests

6. CONCLUSIONS

- 6.1 General
- 6.2 Future

FIGURES

APPENDIX A

APPENDIX B

REFERENCES

LIST OF FIGURES

<u>Figure</u>	<u>Title</u>	<u>Page</u>
1	Plan View, Facility for Test Series No. 1	
2	Front View, Facility for Test Series No. 1	
3	Photographs of Test Facility	
	a) Front View	
	b) Angle View	
4	Photographs of Test Facility	
	a) Air Compressor	
	b) Air Injection Manifold	
5	Pump Characteristics	
6	Dimensionless Pump Characteristics	
7	Schematic Diagram of Facility for Test Series No. 2	
8	Photographs of Test Facility	
	a) Accumulator and Level-Trol	
	b) Vacuum Pump and Flow Meter	
9	Single Port Injection System	
10	Balloon Air Injection Device	
11	Submerged Valve Injection System	
12	Test Series No. 1 - Head versus Discharge as Function of Discharge Air Percent	
13	Test Series No. 1 - Head versus Discharge as Function of Suction Air Percent	
14	Head versus Suction Air Percent	
15	Air Percent at Break Point versus QDIM at Zero Air Percent	
16	Net Positive Suction Head versus Dimensionless Discharge	



## 1. INTRODUCTION

### 1.1 Background

Dredge pumps may encounter mixtures consisting of widely varying proportions of solids, liquids, and gases. No particular difficulty is experienced when liquid-solid mixtures are pumped, except that the pump may choke if the density of the material in the suction line is too high. In normal dredging operations, the specific gravity of the mixture pumped is about 1.2, although laboratory experiments indicate that the dredge pump would operate satisfactorily up to a specific gravity of about 1.45, which corresponds to the consistency of a thick catsup. A choking condition is alleviated by either lifting the drag head out of the mud, or by admitting water to the suction line.

When materials containing a considerable amount of entrapped or dissolved gas are encountered, the gas which enters the suction line of the dredge pump may accumulate in such quantities that the flow of solids discharged by the pump is severely reduced or pumping is completely stopped. The latter condition results in the pump losing its prime. In recent years, the difference between actual choking and stoppage of the pump due to excessive gas has been recognized and the need for gas removal from the suction line has become apparent.

The gases are products of decomposition of organic matter in the bottom material. They are dissolved in the water forming a part of the "in situ" material and, if the water is saturated, bubbles form throughout the material. Since mud usually has high viscosity such bubbles may be retained in the mixture for many years. Analysis of

samples indicates a gas mixture with range of methane ( $\text{CH}_4$ ) from 0 to 85%, nitrogen ( $\text{N}_2$ ) from 0.2 to 98.8%, hydrogen ( $\text{H}_2$ ) from 0.6 to 29.8%, oxygen ( $\text{O}_2$ ) from 0.4 to 12.1%, and carbon dioxide ( $\text{CO}_2$ ) from 1.0 to 14.6%. Methane gas is, of course, inflammable and the need to remove it from the suction line is also important for fire safety.

## 1.2 Scope of Project

The project was originally divided into four parts: Phase A, Literature Search and Formulation of Test Program; Phase B, Formulation of Specific Test Set-ups and Establishment of Test Schedule; Phase C, Establishment of Test Facility and Performance of Model with Water only; Phase D, Performance of Model with Solid-Water Mixtures. Phases A and B have been completed and the results reported to the sponsor (1,2)<sup>1</sup>. This report describes Test Series No. 1 and No. 2, Phase C, and additional studies of air injection methods.

## 1.3 Test Facility

The test facility consists of two large tanks connected by the model dredge pump system and a return line. The model test facility was designed to simulate the prototype condition as closely as possible. The drag head was not modeled, but an attempt was made to simulate it by a set of orifices installed at the entrance to the suction pipe. Air has been used in the model to simulate the gas since it was economical and closely approximates the solubility of methane, the gas most

---

<sup>1</sup>Numbers in parentheses refer to items in the list of references.

frequently encountered in the field. The air was injected just upstream of the entrance to the suction pipe.

Measurements of suction pressure and discharge pressure, water flow rate, and temperature were taken. In addition, the volume of air introduced into the suction line as well as temperature and pressure was monitored.

#### 1.4 Results to Date

Test Series No. 1 was conducted to determine the effect of air content on pump operation. The air content is given as the percentage by volume of the water flow rate, and is for pump suction conditions. Air contents less than 9 percent have little effect on pump operation, reducing the head by less than 8 percent for a fixed value of discharge. However, air contents above 9 percent cause a large and unstable drop in pump head. The pump became filled with air and lost its prime for air contents approaching 20 percent.

Test Series No. 2 was carried out to determine the effectiveness of the gas removal system. Manual vacuum control did not result in any gas removal unless water was also drawn through the vacuum system. The use of the Level-Trol to control an air admission valve in response to water level fluctuation in the accumulator resulted in some gas removal at high air flows. With the Level-Trol in operation, the pump did not lose its prime until the air quantity at suction reached 25 percent.

An additional set of tests was run to determine if the method of air injection had an effect on the gas removal system. The importance of air injection was demonstrated, as slug type air flow was more readily removed. A method was developed to provide pulsed slug flow through a spring action valve on a large air pipe just outside the end of the suction line.

#### 1.5 Future Plans

Quantitative measurements are to be carried out using the slug injection method. Following these tests, a new accumulator with a sloping shoulder on the downstream side will be installed, and visual as well as quantitative studies will be made. The use of a water driven ejector in place of the vacuum pump will also be investigated. This is a continuation of Phase C. Plans for Phase D, Performance of Model with Solid-Water Mixtures, remain to be formulated.

## 2. EXPERIMENTAL STUDY PROGRAM

### 2.1 Discussion

The objectives of the study program were: (a) to build a scale model of a dredge suction system; (b) to study the flow of a gas-water mixture in this system; (c) to install a gas removal system, and (d) to evaluate the effectiveness of the removal system. Hopefully, recommendations could then be made for modifications to existing gas removal systems so that they could operate more efficiently.

The test objectives seemed to indicate a basic feeling of those concerned that existing removal systems "almost worked," and all that was required were some fairly minor changes in instrumentation and control devices. This is evidenced by the fact that formulation of specific test set-ups (Phase B) proposed installation of equipment which was the same as that already in operation on dredges like Essayons, Goethals, and Comber. Visits to these dredges by the investigators did not give encouragement that the existing systems were effective in removing gas, or that they "really did work."

The basic ideas for gas removal systems apparently come from two patents<sup>\*</sup> granted to Mr. Richard T. Hoffman. These patents were filed in 1947, and covered both the vacuum pump system and the ejector system used on Army dredges. The idea is simply that entrained gas will collect in an enlargement on top of the suction pipe and this gas can

---

\* U. S. Patents 2,795,873, and 3,119,344.

then be drawn off with a suction pressure. The suction could come from either a vacuum pump or an ejector. Although this is the basic concept, in actual practice the removal systems have a considerable amount of auxiliary apparatus to prevent solids and water from being drawn through the vacuum pump.

The gas removal equipment installed on existing dredges provides no means of observing the flow of gas into the system. In fact, the only indication of positive results with the prototype systems is an occasional odor of gas from the exhaust of the removal system. The unpredictable occurrence of gas in actual dredging operations makes the evaluation of removal systems by production data very difficult. This lack of information from operational gas removal systems leaves unanswered the question as to whether the existing systems are at all effective in removing entrained gas from the dredged material. The purposes of this study program are then redefined. First, the behavior of gas in the suction pipe must be studied. Without this basic information on where the gas collects in the suction pipe it is not possible to effectively install a removal system. The second objective should be to determine the effectiveness of the existing prototype installations. This can be determined by installing a similar system on the model and observing its behavior. Finally, it was intended that observation of the model performance would allow practical recommendations to be made for the improvement of the prototype removal systems.

The use of clear water rather than mud for the model pump was a necessary simplification. Mud would make visual observations much

more difficult, and would have been a constant source of difficulty in the laboratory measuring and control equipment. However, Phase D has been included to check the performance of the recommended system with solid-water-gas mixtures.

## 2.2 Model-Prototype Relations

The results presented in this report are based on tests performed with a one-eighth scale model pump and drag arm. It is, therefore, useful to briefly discuss the similarity laws used in scale modeling of centrifugal pumps.

The use of models to study prototype pumps requires geometric similitude as well as geometrically similar vector diagrams of the velocity entering and leaving the impeller. Viscous effects must be neglected as it is generally impossible to satisfy the geometric similarity requirements, and have equal Reynolds numbers in the model and in the prototype. However, the modern technique of conducting model pump tests at prototype heads results in higher Reynolds numbers than might be expected, thus reducing the error due to incorrectly modeled viscous forces.

The most important action in a pump is the dynamic transfer of energy from the rotating impeller to the moving fluid. If two pumps are geometrically similar and have similar velocity vector diagrams they are considered homologous. Homologous pumps also have similar streamlines, and for practical purposes, dynamic similitude exists. It is, therefore, assumed that the scale model pump used for the experiments can accurately predict the performance characteristics of the prototype pump.

The prediction of prototype performance from tests of a homologous model requires the use of certain general laws of similarity. These similarity laws define a group of dimensionless terms which in turn can be used to predict the performance of the prototype pump.

### Dimensionless Terms

#### A. Dimensionless Head, HDIM

The physical meaning of HDIM (also called specific head) may be related to the input energy per unit mass per revolution for an impeller of 1 foot diameter.

$$\text{HDIM} = \frac{gH}{N^2 D^2}$$

where:

HDIM = dimensionless head

g = acceleration of gravity, ft./sec.<sup>2</sup>

H = total dynamic head, ft. of fluid

N = rotational speed, radians/sec.

D = impeller diameter, ft.

In these tests, the head is taken to be equal in the model and in the prototype. When the values of HDIM for the model and prototype are equated, the following relation between prototype speed and model speed is determined for a geometric scale ratio of 1/8:

$$N_m = 8 N_p$$



B. Dimensionless Discharge, QDIM

The physical meaning of QDIM (also called specific capacity) is related to the volume of fluid pumped per unit revolution per second, with an impeller of 1 foot diameter.

$$QDIM = \frac{Q}{ND^3}$$

where:

QDIM = dimensionless discharge

Q = discharge, ft.<sup>3</sup>/sec.

Substituting the speed relation required by the equal heads of the model and prototype and the appropriate geometric ratio, the following relation between prototype discharge and model discharge is determined:

$$Q_m = Q_p / 64$$

C. Dimensionless Brake Horsepower

Brake Horsepower is a measure of the energy input to the pump shaft. Pump efficiency is defined as the ratio of pump energy output to the energy input applied to the pump shaft. It follows that:

$$EFF = \frac{WHP}{BHP}$$

where:

EFF = efficiency

WHP = power transferred to fluid, horsepower

BHP = power supplied to pump, horsepower

The assumption is made that the efficiency in the model will equal that of the prototype. Actually, prototype efficiencies are usually slightly higher than those in the model due to higher relative roughness and lower Reynolds number in the model. The relation between model and prototype brake horsepower is

$$BHP_m = BHP_p / 64$$

if the pumped fluids are the same.

### 2.3 Detailed Program

#### Test Series No. 1

The first test series was concerned with the general observation of air injected at the downstream end of the suction pipe. This air was injected through sixteen holes located around a flange at the end of the suction pipe. The accumulator and gas removal equipment were not installed for this test series.

#### (1) Objectives:

- a. To study the behavior of the air injected into the suction system. This included visual

observations on the position of the gas bubbles as they moved up the suction pipe.

- b. To determine the amount of air that caused pump collapse at various flow rates.
- c. To obtain reference data for evaluating the system with the gas removal equipment installed.

(2) Parameters:

The main parameters were flow rate and gas content. The pump speed and suction geometry were briefly investigated to see if they were significant parameters.

(3) Procedure:

- a. Select an initial water flow rate.
- b. Start the pump motor and set the desired speed.  
(1140 rpm is the design speed for the model pump).
- c. Open the discharge valve until the selected discharge is obtained.
- d. Measure the control parameters, such as pressure, voltage, amperage, and flow rate.
- e. Inject a controlled amount of air into the suction pipe.
- f. Observe the rise, position and size of the gas bubbles using strobotac and motion pictures.
- g. Increase the air flow and repeat steps, d, e, and f, holding the pump speed constant.

- h. Note the amount of air which causes complete collapse of the dredge pump.

The previous procedure was repeated for seven different flow rates between 400 and 1000 gpm.

(4) Analysis:

Plot curves showing the effect of air content on pump discharge and on the total dynamic head.

Test Series No. 2

The second test series required the installation of a plexi-glas accumulator and a vacuum pump. After the installation of this gas removal equipment, the dredge pump was again tested and the performance of the system was recorded.

(1) Objectives:

- a. Determine if the gas removal system is beneficial to the performance of the dredge pump.
- b. Determine the amount of gas which is removed by the removal system.
- c. Investigate the use of various control devices (Level-Trol and diaphragm valve) to improve the efficiency of the removal system.
- d. Based on the observations of Test Series No. 1 and prototype clearances, investigate the effect of varying the accumulator location.

(2) Procedure:

Repeat the procedure of Test Series No. 1 with the gas removal system in operation. Record the amount of gas removed from the accumulator. These tests should be repeated for each accumulator location, and for different control devices if the removal system appears to be functional.

(3) Analysis:

Plot curves similar to those of Test Series No. 1, showing pump performance with removal equipment operating.

### 3. EXPERIMENTAL FACILITY

#### 3.1 Facility for Test Series No. 1

The test set-up consisted of a suction tank, suction pipe, pump, discharge pipe, discharge tank, and a return pipe all connected in a continuous flow loop. External to the flow system is the pump motor and the air compressor. The layout of the equipment is shown in Figs. 1 and 2. Figure 3a shows the front of Tank B. The suction pipe and dredge pump may be seen in the left center of the picture. One of the injected air flow meters is located in the center of Tank B. Above and to the right of the flow meter the filters in the air line may be seen. Figure 3b shows the pump and suction pipe as well as the manometer board for measuring pump pressures. The magnetic flow meter is directly above the pump, while the flow rate indicator and electrical meters are located to the left of the manometer board. Figure 4a shows the rotary air compressor with the associated control and safety devices. Figure 4b is a close-up of the air injection manifold which is visible through the window in Tank B in Fig. 3a.

##### 3.1.1 Pump

The pump is a 1 to 8 scale model of the centrifugal pumps on the Army Corps of Engineers' hopper dredge Essayons. The pump is a radial flow type of design which means the fluid is turned ninety degrees as it passes through the pump. The front of the pump casing is made of plexiglas so that actual flow conditions can be observed. The remainder of the pump casing is a bronze casting. The model pump and the prototype pumps were manufactured by the Ellicott Machine Corporation.

### 3.1.2 Impeller

The pump impeller is 10.5 inches in diameter and has five vanes. The vane layout is in the form of an involute curve with an entrance angle of  $45^\circ$  and an exit angle of  $22^\circ 30'$ . The pump impeller is a bronze casting, but it is fitted with a plexiglas suction-side shroud.

### 3.1.3 Pump Characteristics Without Air

In order to characterize the pump used in this investigation, a standard plot of the pump's characteristics is given in Fig. 5, while dimensionless characteristics are given in Fig. 6. Specific speed is a dimensionless parameter which can be used to describe a pump. The specific speed is defined as the revolutions per minute needed to produce a discharge of 1 GPM at a head of 1 foot of water. The discharge used is the one with the maximum efficiency. This is easily determined from the plot of the pump characteristics. Stepanoff defines specific speed as follows (3):

$$\text{Specific Speed} = \frac{n(Q)^{1/2}}{H^{3/4}}$$

where:

n = speed, revolutions/minute

Q = discharge, gallons/minute

H = head, ft.

From Fig. 5 is seen that a discharge of 1100 GPM and a head of 67 feet correspond to the maximum efficiency. Thus, the specific speed of the pump is 2040.

#### 3.1.4 Motor

The motor is a 40-hp, Life Line H, Frame 405, direct current motor manufactured by Westinghouse Electric Corporation, Buffalo, New York. This motor is designed to provide a wide speed range and accurate speed regulation. The motor was calibrated so that its power output could be calculated from input voltage and amperage data.

#### 3.1.5 Magnetic Flow Meter

The discharge from the pump was measured with a Magnetic Flow Meter manufactured by the Foxboro Company, Foxboro, Massachusetts. In a magnetic flow meter a glass pipe is used with a magnetic field induced across the pipe by an electromagnet. The fluid flowing through the pipe generates a voltage which is proportional to the velocity of the flowing fluid. Two electrodes placed in the pipe wall pick up this voltage, and transfer it to a Dynalog Recorder. The recorder is used to convert the generated voltage into a readout of a pen on a 24-hour revolving chart. The flow meter and recorder are shown in Fig. 3b.

Under test conditions, the discharge is a mixture of air and water. The flow meter reads the volume flow rate of the total air-water mixture. The only assumptions are that the meter tube is running full and that the discharge is a homogeneous mixture.



### 3.1.6 Pump Speed

Originally, a tachometer generator was mounted on the shaft of the D.C. motor. This arrangement gave inaccurate speed measurement, possibly because of misalignment of the generator. The tachometer was removed, and the speed was measured with a Hasler speed indicator. The speed was also monitored frequently with a stroboscopic tachometer.

### 3.1.7 Air Compressor

The air was provided by a single stage rotary compressor, model 5CCA, which is rated at 45 CFM at a discharge pressure of 30 psig. This compressor was manufactured by Allis-Chalmers, Milwaukee, Wisconsin. The compressor is powered by a 7.5 HP A.C. motor. The compressed air is fed through an aftercooler, a separator, and a filter before it is injected into the suction pipe. The compressor is shown in Fig. 4a. The separator and filter are visible at the top of Fig. 3a.

### 3.1.8 Air Injection

Air injection is accomplished by a manifold with 16 hoses connected to 1/16 inch diameter holes drilled through the end flange of the suction pipe. The injection holes were located 2 inches from the end of the suction pipe. Figure 4b is a close-up photograph of this injector.

### 3.1.9 Measuring Equipment

The injected air flow was measured with a rotameter calibrated to read SCFM air at 25 psia, 70°F. The air temperature at the flow meter was measured with a calibrated resistance wire temperature gage. The air

pressure at the meter is also measured, and all air volumes were corrected to the above mentioned standard conditions.

The suction head was measured with a 50 inch range mercury manometer. The suction head was measured in the suction pipe one inch upstream from the outer edge of the pump face. The discharge head is measured with two 100 inch range mercury manometers. It was measured in the discharge pipe directly before the magnetic flow meter 12.8 inches above the pump centerline.

### 3.2 Facility for Test Series No. 2

The test set-up for this series of tests remained the same, except for the installation of the gas removal equipment. A 4-1/2 inch square plexiglas accumulator was added to the top of the suction pipe. The center of the accumulator is 12-3/4 inches from the face of the pump. The accumulator is 17 inches high. A schematic sketch of the gas removal system is shown in Fig. 7. Figure 8a shows the accumulator installed with the Level-Trol and automatic air admission valve on either side of it. Figure 8b shows the vacuum pump and related equipment.

#### 3.2.1 Vacuum Receiver

This is a 20 x 48 inch cylindrical tank galvanized inside and outside. It has a capacity of sixty gallons and serves to keep water from entering the vacuum pump. The receiver is near the left edge of Fig. 8b.

### 3.2.2 Vacuum Pump

The vacuum pump is a piston type, V244, with 4 x 4 inch cylinders. It is driven by a 2 HP A.C. motor. The pump has a maximum vacuum of 29.65 inches mercury, and a piston displacement of 16.0 CFM. It was manufactured by Ingersoll-Rand Co., Painted Post, New York. The vacuum pump is at the lower left center of Fig. 8b.

### 3.2.3 Vacuum Flow Meter

A laminar air flow meter was used to measure air removed from the system. This meter is a model D-23170 manufactured by the Meriam Instrument Co., Cleveland, Ohio. This appears in the upper right foreground of Fig. 8b.

### 3.2.4 Accumulator Fluid Level Controller

This was a Fisher, type 2502-249 Level-Trol. It has a 3 inch diameter by 13 inch long float chamber. The Level-Trol was manufactured by the Fisher Governor Co., Marshall Town, Iowa. This device is used to keep a constant level in the accumulator. It does this by sensing a rising liquid level in the accumulator and activating a diaphragm valve which admits atmospheric air to reduce the vacuum and thus lower the level in the accumulator. This equipment appears in Fig. 8a. The Level-Trol is in the upper right, attached to the end of Tank B. The diaphragm valve is to the left of the accumulator.

## 3.3 Equipment for Air Injection Tests

The various injection methods are shown by sketches. The first trial, with a single inlet port in the center of the end of the suction

line, is shown in Fig. 9. The arrangement for the balloon scheme is shown in Fig. 10. The large (2 1/2 inch) inlet with a lever actuated ball valve just upstream from the end of the air pipe, is shown in Fig. 11.

## 4. EXPERIMENTAL STUDIES

### 4.1 Introductory Comments

The original experimental program was modified because of practical difficulties. The use of an orifice to simulate the drag head proved to be impractical, and had to be discarded after considerable time and effort. The intended measurements of air flow rate proved very difficult, and required much trial and error work before even partial success was achieved. The control of accumulator liquid level and vacuum was also a problem. The Level-Trol device was eventually installed properly and operated as planned.

Subsequently, suitable test procedures were developed for both test series. High and medium speed movies were taken of desired flow conditions, especially during Test Series No. 2 with the accumulator installed.

### 4.2 Difficulties Encountered

Many difficult problems were encountered in the experimental instrumentation and operation. Some of these problems were compounded by unexpected delays in equipment delivery and problems of installation.

#### 4.2.1 Installation Delays

Delays in delivery of the air compressor, associated equipment, and the bronze-plexiglas pump casing held back the initial test date over four (4) months. Additional delays occurred when the vacuum pump and vacuum control equipment were purchased for Test Series No. 2.

Two serious mistakes were made by the electrical contractor during installation. The polarity of the D.C. motor was reversed. This caused the pump impeller to spin off the shaft and resulted in damage to the impeller. This caused a considerable delay while the impeller was repaired. The electricians also wired the compressor motor for 120 volts instead of the specified 220 volts. This resulted in a burned out switch box, but no damage to the compressor.

The old volumetric tank which was modified and was used as the discharge tank (Tank B, Fig. 1) sustained a bracing failure when subjected to pumping pressure. This required draining the system and welding in new bracing with all the usual leakage problems when gaskets are allowed to dry.

These unexpected and uncontrollable delays in putting the test equipment into operation delayed the completion of Test Series No. 1 by approximately 6 months. Permission from the sponsor to begin preliminary work on Test Series No. 2 before completion of Test Series No. 1, recovered about 2 months of the lost time.

#### 4.2.2 Experimental Difficulties

The first problem arose when various sized orifices were used at the inlet to the model drag arm. These were to simulate the head loss and flow control by the prototype drag head and bottom consistency. The two larger orifices caused a decrease in flow rate of only 2.5 percent for zero air. The two smaller orifices cavitated unless the flow rate was severely restricted by using the discharge valve.

Though discharge control of flow rate was not desired since it is not used on prototype dredges, it was accepted with limitations. Alternatives, including a model drag head and movable tank bottom, were dismissed as either being too expensive or requiring too much time.

The efforts to use a set of orifices were time consuming, not to mention that a day was required to change orifice plates.

The air mass balance mentioned in Section 2.2 required measurement of air flow at three locations. The excess air not removed by the removal system was supposed to collect in discharge tank B and to be measured by a flow meter. In addition, the air injection rate and the air flow rate from the gas removal system were to be measured. The amount of air removed through the accumulator was measured by a laminar air flow meter. The adaption of this meter to the vacuum system is described in Section 4.3. The amount of air going into or out of solution in the water could be obtained from the air diffusion equations (4). As for the amount of air collected in Tank B, unforeseen difficulties were encountered. A steady flow of both air and water could not be established between Tank A and B. When air enters Tank B, it follows a very random path to the outlet. The air passes through the flow meter in an unsteady manner, carrying large quantities of water with it. The quiescent surface with an air pocket of appreciable size above did not form as originally expected.

The vacuum system installed to remove air from the accumulator required the trial of many variations in geometry and location of

equipment. Despite an eight cubic foot scrubber tank and a filter, water was drawn through the vacuum pump when a vacuum noticeably greater than dredge pump suction was applied. Addition of an 8 foot high pipe loop or even a 30 foot high hose loop did not stop the passage of the air-water mixture through the vacuum pump and flow meter. An enlargement near the top of the loop might have stopped this action, but was not tried due to a lack of time.

The use of the Level-Trol to control vacuum by admitting atmospheric air to the vacuum line prevented carry-over or pumping of water. However, a steady water level in the accumulator was not achieved since the response of the Level-Trol and the time to admit sufficient air was too slow. This resulted in a periodic fluctuation of water level in the accumulator. But this facility did remove some air when the dredge pump was near the collapse point.

#### 4.3 Development of Air Flow Meter

A laminar air flow meter was installed as described in Section 3.2 to measure the amount of removed air. The laminar air flow meter consisted of two parts, the laminar flow element and an inclined manometer.

The basic relation between flow rate and pressure drop for this air flow meter is based on the Hagen-Poiseuille Law. Unfortunately, this law applies only to laminar flow while most of the flows encountered in engineering work are turbulent. It is the function of the laminar



flow element to force the flow to become laminar by a severe reduction in size of flow passage. Referring to the Reynolds Number

$$N_R = \frac{ud\rho}{\mu}$$

which is the criterion for distinguishing between laminar and turbulent flow, it is seen that the only free terms are fluid velocity,  $u$ , and the tube diameter,  $d$ , since for a given fluid viscosity,  $\mu$ , and density,  $\rho$ , will be fixed. The laminar flow element channels the flow through myriad parallel ducts which keeps the velocity about the same as in the pipe, while reducing the duct dimension sufficiently to produce laminar flow.

A correction for air temperature is needed since the flow varies inversely with the viscosity which is dependent on temperature. For air, an increase of  $10^{\circ}\text{F}$  will increase the differential pressure 15% for the same volume flow.

Weight or mass flow rates must be used in comparing air flow rates measured at different pressures and temperatures. For such purposes, the effect of pressure on density must be taken into account. The Reynolds Number is also directly proportional to the fluid density.

There are two possible locations for the laminar air flow meter. One is on the vacuum pump exhaust as indicated in Fig. 7. The other one is to locate the air flow meter between the scrubber tank and the vacuum pump. However, with this arrangement, there is a possibility

that the manometer gage fluid will be drawn into the vacuum line due to reverse flow. Also, the manufacturer could offer no advice or assurance on the correct operation of the meter at vacuum conditions.

Consequently, the flow meter was placed on the exhaust side of the vacuum pump. Since the temperature increased throughout a test run, the correction for temperature became very large. This resulted in apparent flow indications which were induced entirely by the temperature rise which often reached 50°F. The pressures were always slightly above atmospheric pressure. The laminar flow device damped the unsteady flow from the reciprocating vacuum pump.

#### 4.4 Experimental Procedures

The description of experimental procedures will be more easily followed if reference is made to Fig. 7. The difference in procedure between Test Series No. 1 and Test Series No. 2 is noted as necessary.

##### a. Preliminary

Before each experiment was started, the initial readings of the manometer were recorded. In order to have more accurate readings, this procedure was repeated at the end of the experiment. The air and water temperatures and the atmospheric pressure were also recorded.

##### b. Starting the Equipment

The pump was driven by a D.C. motor. Before the pump was started, the sealing water, flow meter, and voltage were turned on and adjusted. The pump speed was measured by a tachometer and checked with

a strobotac. (Usually, the pump was run at 1440 rpm). After the speed was set, the discharge valve was opened gradually and adjusted to desired flow rate. The pump speed was checked after the desired flow rate was established.

The following check list shows the equipment used in each test series:

	<u>Test Series No. 1</u>	<u>Test Series No. 2</u>
Pump	X	X
Accumulator		X
Compressor	X	X
Vacuum Pump		X
Level-Trol		X
Laminar Flow Meter		X

c. Setting Variables

For a typical test, the pump speed was set at 1440 rpm, the initial discharge at 1000 gpm, and the injected air pressure at 10 psi. In Test Series No. 2, the vacuum at the vacuum pump was set at 15 inches of mercury (the vacuum level was set by adjusting the relief valve). The amount of injected air was increased gradually until the pump collapsed. In part of Test Series No. 2, the Level-Trol was in operation. The reset frequency was set at minimum in order to have the fastest response possible.

d. Recording Data and Repeating Points

After the desired experimental conditions were established,

the following data were recorded for each injected air flow.

1. Injected air pressure, ususally 10 psig
2. Amount of injected air
3. Laminar flow meter reading (Test Series No. 2 only)
4. Temperature of exhaust air (Test Series No. 2 only)
5. Combined flow rate
6. Suction head
7. Discharge head
8. Motor voltage and amperage
9. Dredging depth
10. Remarks

Test Series No. 1 included 53 tests for a total of 416 runs. Test Series No. 2 included 21 tests totaling 148 runs. The data from each test were processed by computer. The Air Injection Test Series included 15 tests in which visual observation was the primary source of data.

e. Shutting Down

The test was terminated after the pump collapsed. The injected air, the vacuum pump, and finally the dredge pump were turned off.

4.5 Visual Observations

Both medium speed (128 frames/sec.) movies and high speed movies (approximately 3000 frames/sec.) were taken to study the air-

water flow pattern in the suction line, and in the accumulator.

The medium speed movies were quite useful in Test Series No. 1 as sequences from two perpendicular directions could be used to locate the highest concentration of air. For this test series the high speed films showed only that the air was widely dispersed in small bubbles at all air flows less than that at which pump collapse was incipient.

For Test Series No. 2 the high speed movies were necessary to observe the flow pattern in the accumulator. There was no obvious change in flow pattern in the suction pipe so few medium speed movies were taken in this test series.

High speed movies of the accumulator and sloping portion of the suction pipe were used to observe the details of air bubble size, shape, and distribution. These movies have been spliced with titles onto an 800 foot reel.

A separate written commentary was written to accompany the edited movies and includes discussion which is meaningful only when watching the movies. The edited movies and the commentary have been sent to the Marine Design Section, Philadelphia District, U. S. Army Corps of Engineers.

The Strobotac and Strobolume were used to observe conditions in the pump as the air flow rate was varied.

## 5. EXPERIMENTAL RESULTS

### 5.1 Data Analysis

A sample calculation is included here to illustrate the procedure for data reduction, and to show the method for calculating values of the variables which appear in the various plots. The basic data reduction was carried out on the GE 225 digital computer in the Lehigh University Computer Center. The final version of the computer program is shown in Appendix B. The language is LEWIZ (5).

The sample calculation is for Test No. 41, Runs No. 1 (no air) and No. 6 (with air).

#### Initial Readings: (for entire test)

Pump Speed, RPM, 1440  
Discharge Manometers, inches 1.2, 0.8, 0.9, 0.8  
Suction Manometer, inches 0.4, 0.4  
Atmospheric Pressure, inches of mercury, 29.90  
Vapor Pressure, ft. of water, 0.83  
Air Temperature, °C, 29  
Water Temperature, °C, 21

#### Readings, Run No. 1:

Flow Rate, gpm, 1000  
Discharge Manometers, inches 14.0, 13.1, 13.2, 13.2  
Suction Manometer, inches 4.8, 4.3  
Motor Current, amperes, 83  
Motor Voltage, volts, 241  
Input Air Pressure, psi, 0  
Input Air Flow, cfm, 0

#### Computed Quantities, Run No. 1:

Flow Rate = 2.28 cfs  
Discharge Pressure = 53.12 ft. of water  
Suction Pressure = -10.28 ft. of water  
Total Dynamic Head = 68.27 ft. of water

Water Horsepower = 17.26  
Brake Horsepower = 73.92  
Dimensionless Head = 0.126  
Dimensionless Discharge = 0.0221

Reading, Run No. 6:

Flow Rate, gpm, 965  
Discharge Manometer, inches 13.8, 13.8, 13.1, 13.0  
Suction Manometer, inches 4.6, 4.2  
Motor Current, amperes, 81  
Motor Voltage, volts, 240  
Input Air Pressure, psi, 10.0  
Input Air Flow, cfm, 4.55

Computed Quantities, Run No. 6:

Total Flow Rate = 2.15 cfs  
Discharge Air Flow = 0.05 cfs  
Suction Air Flow = 0.18 cfs  
Water Flow Rate = 2.10 cfs  
Discharge Air Percent = 2.4  
Suction Air Percent = 8.7  
Discharge Pressure = 53.43 ft. of mixture  
Suction Pressure = -10.80 ft. of mixture  
Total Dynamic Head = 68.20 ft. of mixture  
Water Horsepower = 16.24  
Brake Horsepower = 22.69  
Efficiency, Percent = 71.59  
Dimensionless Head = 0.0886  
Dimensionless Discharge = 0.0177

## 5.2 Test Series No. 1

As stated in Section 2.2, the purpose of Test Series No. 1 was to determine dredging performance with an air-water mixture, but with no gas removal system. The variables were flow rate, pump speed, and air content. The flow rate was varied by manipulating the discharge valve with zero air flow. Once set, the discharge valve was not used during a given test. Pump speed was maintained at a predetermined value throughout each test. Data was taken for each test with a fixed air flow rate.

Figure 6 shows the dimensionless head, dimensionless horsepower, and efficiency versus dimensionless discharge curves for the pump. As the three pump speeds all fit very well on these lines, most tests were run at 1440 RPM with a few speed check tests run at 1300 or 1600 RPM. Figure 5 shows the actual head, horsepower, and discharge relations for a pump speed of 1440 RPM.

The total dynamic head, H, developed by the pump is obtained from application of the steady flow energy equation between a section at pump suction, and another section in the discharge line. For a homogeneous mixture, the heads are expressed in feet of the flowing fluid mixture. Thus, the total dynamic head is given by:

$$H = \left( \frac{p}{\gamma} + z + \frac{u^2}{2} \right)_d - \left( \frac{p}{\gamma} + z + \frac{u^2}{2} \right)_s$$

where:

p = pressure, pounds per square foot

$\gamma$  = unit weight of mixture, pounds per cubic foot

u = velocity, feet per second

z = elevation, feet

d = refers to discharge section

s = refers to suction section

The velocity is calculated using the total flow rate and the area for each section. Since the pressure changes from suction to discharge, the volume flow rate of air changes accordingly though the mass or weight flow rate is the same. Thus, the local total volume



flow rate and the local unit weight of the assumed homogeneous mixture are different for suction and discharge conditions. The sample calculation in Section 5.1 illustrates this as the air flow at pump suction is 0.18 cfs, while the air flow at discharge is 0.05 cfs.

The data for Test Series No. 1 were originally reported in Status Report No. 15 (6) with the heads expressed in feet of water and air percentages given for air flow rates determined at standard conditions (70°F, 25 psia). Since the discharge pressure is approximately 25 psia, air percentages at pump discharge are similar to those shown. For comparative purposes, Fig. 12 shows the effect of air on the dimensionless head - discharge relation for the dredge pump as reported originally. This figure shows that only moderate reductions in discharge and head occur if the air percentage is less than 4. When the air flow increases above 4 percent, a sudden and unstable drop in head and discharge occurs with final "collapse", or stoppage taking place at about 10 percent air flow. The precise collapse point is not predictable.

The picture remains similar when the head is put in terms of feet of the mixture, and the air flow is calculated for pump suction conditions. Figure 13 presents the data in this form. The obvious change is the increase in air percentages. Less apparent in this figure is the initial trend of the test data. The discharge decreases while the head remains nearly constant as the air flow is increased from 0 to 9 percent of the water flow. At this point, the water flow rate has dropped approximately 10 percent. If the air flow is increased to approximately 12 percent, a sudden drop in both head and discharge

occurs. The head drops 20 percent while the flow rate drops to 5 percent below the zero air flow level. The operating conditions for air flows above 9 percent are very unstable, and permit recording few data points at high air flows. Tests with lower initial water flows (QDIM less than 0.015, or actual flow less than 700 gpm) ended at lower air flows. This change in collapse point from near 18 percent air to 12 percent air takes place in a narrow range of initial discharges. Lower initial discharge tests end after operating for some length of time at the last set air flow. The tests with higher initial flows end quickly when the air flow is increased above a quasi-stable operation at the previous air flow.

Plotting of the head as a function of air percentage produces curves like the typical ones shown in Fig. 14. The air percentage at which the head initially drops can be defined quite well for each test which was carried past this point. This may be termed the "break point", and Fig. 15 shows the experimental relation between the air percentage at the break point as a function, and the dimensionless discharge for zero air flow. The significance of this relation is that a definite criterion for acceptable air flow rates is given by this rather flat curve. For a wide range of flow rates, up to 9 percent air by volume at pump suction may be handled with no drop in pump head, and only a 10 percent decrease in dredging rate. Thus, the performance of air removal equipment would be adequate, if the air volume passing through the dredge pump were reduced below the 9 percent limit. This is based on a steady flow of air. It is likely that short, intermittent bursts

of higher air volume could be handled with only momentary reduction in dredge production.

From visual observation, the optimum position for the gas removal system appears to be as close to the suction elbow as possible. However, due to the prototype suction line valve, it is impossible to locate the removal system close to the suction line elbow.

### 5.3 Test Series No. 2

Test Series No. 2 was conducted with the gas removal system installed. Several tests were run to see if the change in suction pipe geometry due to the accumulator changed in pump suction conditions. These tests showed that it has no affect on the pump suction conditions.

In the first part of this test series, the water level in the accumulator was not controlled. Neither the experimental data nor visual observation shows any significant amount of air flow out of the system. Tests were run with the vacuum at the vacuum pump varied from zero to thirty inches of mercury. At vacuums lower than the pump suction pressure, atmospheric air was drawn into the suction line through the relief valve on the vacuum line and caused a further decrease in efficiency of the pump. With the vacuum on the top of the accumulator equal to the pump suction pressure, no significant amount of air is removed, and pump operation is not affected. At vacuums higher than pump suction pressure both air and water are carried through the vacuum system. A 34 foot high hose loop and a scrubber tank reduced the chance of drawing water through the vacuum pump. However, this did not result in removal of useful quantities of air from the accumulator.

The Level-trol was used for some test runs, but resulted in air removal only near collapse. An increase of 10 percent in air content at collapse was noted. There was no improvement in the air removal at lower air flows. The response times of the Level-trol and diaphragm operated relief valve were quite slow, and caused an oscillating water level in the accumulator.

The accumulator was tilted 45 degrees in an attempt to get the bottom of the accumulator closer to the main air stream in the suction pipe. However, the air stream was still carried past the accumulator.

The results of Test Series No. 2 are practically identical with the results of Test Series No. 1 shown in Fig. 13. Suction conditions are commonly described by either the "net positive suction head", NPSH, or by the ratio of NPSH to H, the total pump head. Net positive suction head is defined by the equation:

$$\text{NPSH} = \frac{p_{\text{atm}}}{\gamma} + \frac{V_s^2}{2g} + \frac{p_s}{\gamma} - \frac{p_v}{\gamma}$$

where:

atm denotes atmosphere

s denotes pump suction

v denotes water vapor

The ratio of NPSH to H is often labeled,  $\sigma$ , and called the cavitation index. Depending on the pump design, a value of  $\sigma$  below a critical

limit indicates probable cavitation. Figure 16 presents a plot of NPSH versus QDIM for several conditions. The nearly horizontal line at a  $\sigma$  of 0.43 is for no air flow. This indicates that there is no change in the chance of cavitation with varied flow rate within the operating range of the pump when the pumped fluid is clear water. The other line is for varied air flow. Data points for a typical test in each test series are shown and fall on the same line. The trend of this curve may be explained by noting that the suction pressure, which is below atmospheric at normal flow rates, approaches zero quite rapidly with increasing air flow, while the total head drops more gradually. In fact, at collapse the NPSH is approximately given by  $p_{atm} - p_v$ , but the total head drops to zero. This plot was chosen over a plot of NPSH versus Q, since it puts all tests on the same basis with regard to atmospheric conditions and the  $\sigma$  value for no air flow. The data indicates that the gas removal system does little to improve dredge pump suction conditions which are vital to continued operation. In particular, the gas removal system did not prevent the suction pressure and velocity from becoming zero at some air flow rate.

#### 5.4 Air Injection Tests

The failure of the model gas removal system to remove any significant amount of air may have been caused by improper modeling of the prototype air flow. The test facility for Test Series No. 1 and No. 2 provided for continuous injection of air through a manifold of small openings around the inlet to the drag arm. A continuous stream of very fine air bubbles resulted from this method of injection. Though the

air tended to rise in the drag arm, the secondary flow induced by the elbow dispersed the bubbles throughout the flow section at the accumulator. At high flow rates the travel time in the suction line was not sufficient for the air to concentrate in the upper portion of the pipe, and the air is more uniformly distributed than it was at lower flow rates.

Prototype dredges probably encounter gas in conditions conducive to the entry of occasional slugs or bursts of air into the drag arm. This would be quite different in affect on dredging operations than continuous gas flow, even if several slugs were encountered in close succession.

Consequently, a brief visual study of air injection and air flow in the suction line was conducted. Three basic plans were typed before practical method of slug injection was devised.

The first modification was designed to determine the effect of number, size, and location of injection ports. The planned change was from many small ports to fewer larger ports. A scheme involving a single, large, and centrally located port was installed to check the opposite extreme from the original system. This arrangement is illustrated in Fig. 9. Both 1/2 inch and 3/4 inch pipe were tested. Slug flow was not obtained for any water flow rate with either steady or pulsed air flow. For continuous air flow, the air stream broke into fine bubbles, and dispersed throughout the flow before it could be observed in the clear suction pipe. The pulsed flow was obtained by opening and closing the air flow valves near the air flow meters.

The gate valves could not be operated very rapidly, and the length of 1/2 inch pipe (approximately 8 ft.) between the valve and the end of the pipe caused an elongated air mass to be injected. This was also dispersed rapidly into fine bubbles.

These observations showed that changing injector geometry could not effect the desired change in air flow pattern. A valve some distance from the injection point was not effective for producing slug flow. Automatic pressure relief valves were considered, but their response appeared too slow to give compact slugs.

A simplistic innovation was developed. Air filled balloons were lowered into the drag arm inlet where they were punctured by a spike. Figure 10 illustrates the pulley system used to lower and break the balloons. This system produced slug flow. A considerable portion of the air slug rose into the accumulator at a water flow rate of 400 gallons per minute. Unfortunately, this method of producing slug flow is not readily adapted to yield quantitative results.

The third and most successful method of air injection required a valve and small receiver tank at the injection point. This proved to allow successful generation of a wide range of air flow patterns. Depending on the speed of operating the valve any type of flow, from a very short slug to a continuous stream, can be produced. Two versions of this device were tested. Initially, a spring returned quick acting gate valve was installed at the end of the 12 inch long receiver of 2 inch pipe. This valve was opened by means of a nylon lanyard or operating rope and closed by spring action. The spring corroded from

the continuous exposure to water, and regular maintenance was needed to keep the valve operating properly. This is the system shown in Fig. 11. Subsequently, the valve was replaced by a ball valve. The ball valve is operated by means of a pipe extending from the valve stem to an operating lever mounted above the water surface in tank B. This is the current configuration of the air injection system.



## 6. CONCLUSIONS

### 6.1 General

The effect of continuous air or gas flow on dredge pump operation was determined in Test Series No. 1. Gas flows of less than 9 percent of the water flow have only minor effect on the pumping head and flow rate. This percentage is based on volume flow rates calculated at pump suction conditions. Gas flows above 10 percent of the water flow result in unstable flow conditions and in severely reduced head and flow. Depending upon the pumping rate without gas, gas flows of 12 to 20 percent will cause collapse with the pump casing filled with gas. Dredging is suspended until the pump is reprimed with clear water.

The visual observations and movie studies demonstrated that the air is widely dispersed in small bubbles by the turbulent water flow. The continuous injection of air in fine bubbles resulted in a uniform distribution of air throughout the suction pipe. The only concentration occurs at the elbow. Here the density difference and centrifugal effect combine to cause most of the air to collect at the inside of the bend. The air has become widely dispersed before it reaches the pump.

Test Series No. 2 showed that the currently used accumulator and vacuum pump were not effective in removing dispersed gas bubbles. The use of automatic control permitted a slight increase in air percentage at collapse, but caused the water level to oscillate in the

accumulator. With the vacuum system in operation, the accumulator geometry caused no change in gas flow pattern.

More detailed study of air injection methods found that the effectiveness of the accumulator and collapse of the pump are dependent on the nature of the air flow. Individual slugs of air were partially deflected into the accumulator. The pump momentarily lost head and flow, but did not collapse when moderate slugs were injected. As no quantitative measure of air volume was made, the effectiveness of the gas removal system and the ability of the dredge pump to pass intermittent gas flows without collapse could not be related to the size or frequency of the gas slugs.

## 6.2 Future

Four additional test sequences are to be accomplished under the latest contract modification. The first of these test series will be performed on a redesigned accumulator. This accumulator will have a sloping side to allow a wider base for air to enter. It will be made as high as possible to permit study of the influence of liquid level in gas removal. In addition, the effect of stream speed on gas removal will be investigated.

The next test sequence will include measurement of gas volumes for slug flow to determine the proportion of gas flow between the accumulator and dredge pump.

The third phase involves a major change in equipment. The vacuum pump will be replaced by a water driven ejector in order to

compare the effectiveness of the two methods of removing gas from the accumulator.

Finally, comparison of the accumulators and vacuum systems will be made considering the influence of accumulator liquid level and fluid velocity.

7. FIGURES

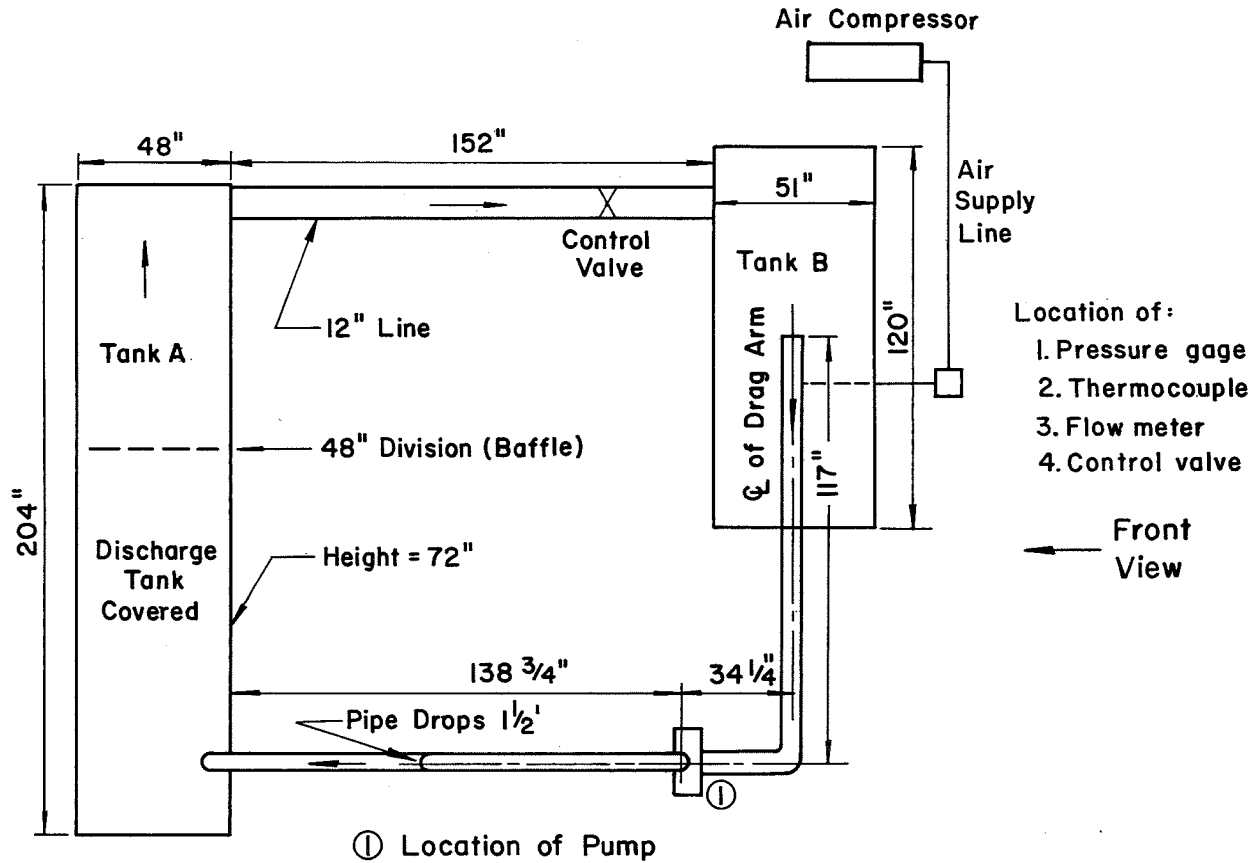

PLAN VIEW OF TEST EQUIPMENT

Not To Scale  
 Drawing No. 310.13

Fig. 1 Plan View, Facility for Test Series No. 1

- Note:
- ① Location of Discharge Tank A
  - ② Supply Tank B with Plexiglas Windows
  - ③ Point of Air Injector

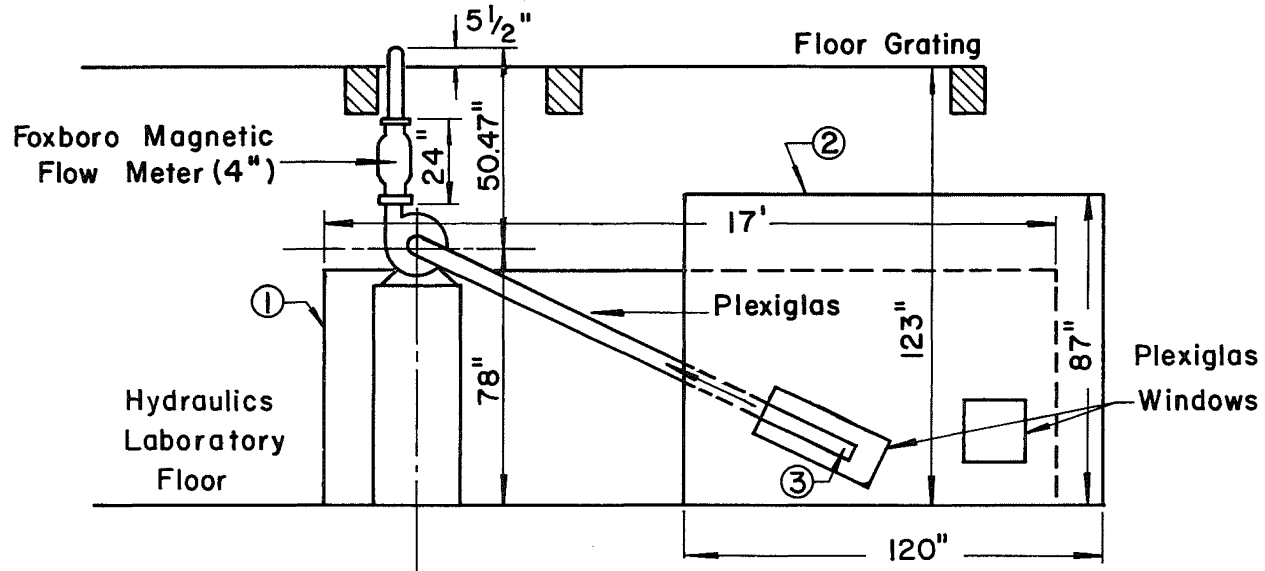

FRONT VIEW OF TEST EQUIPMENT

Not To Scale  
Drawing No. 310.12

Fig. 2 Front View, Facility for Test Series No. 1

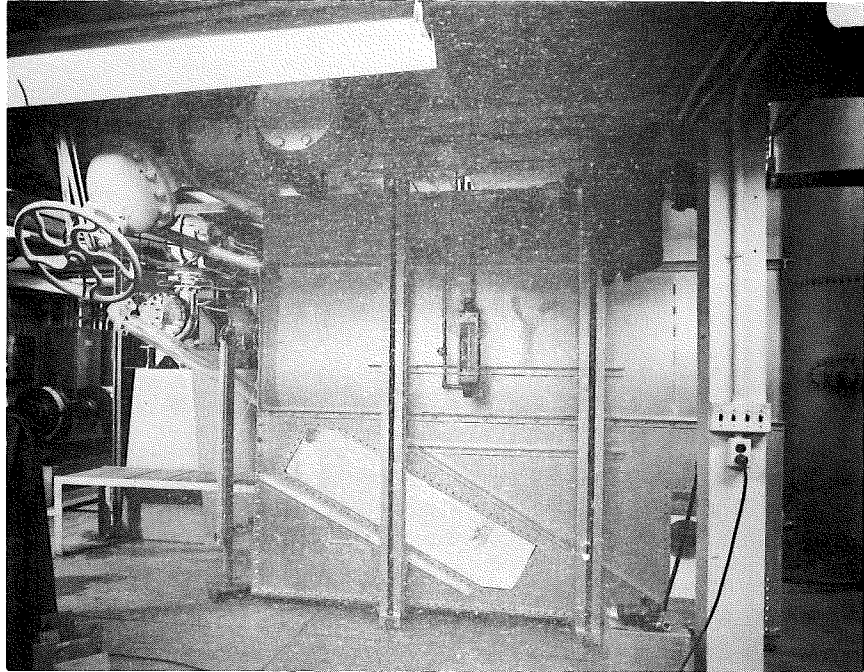

a) Front View

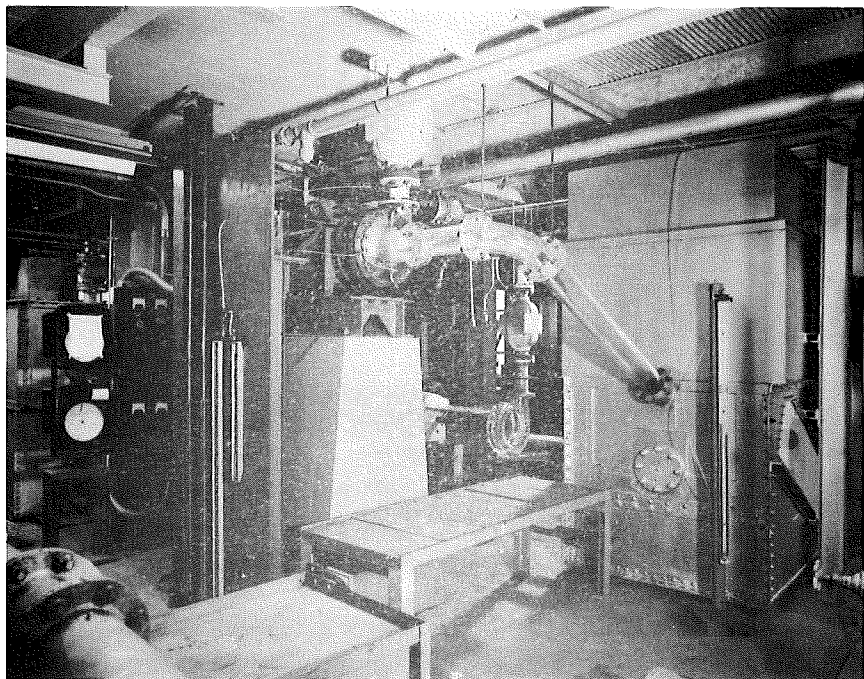

b) Angle View

Fig. 3 Photographs of Test Facility

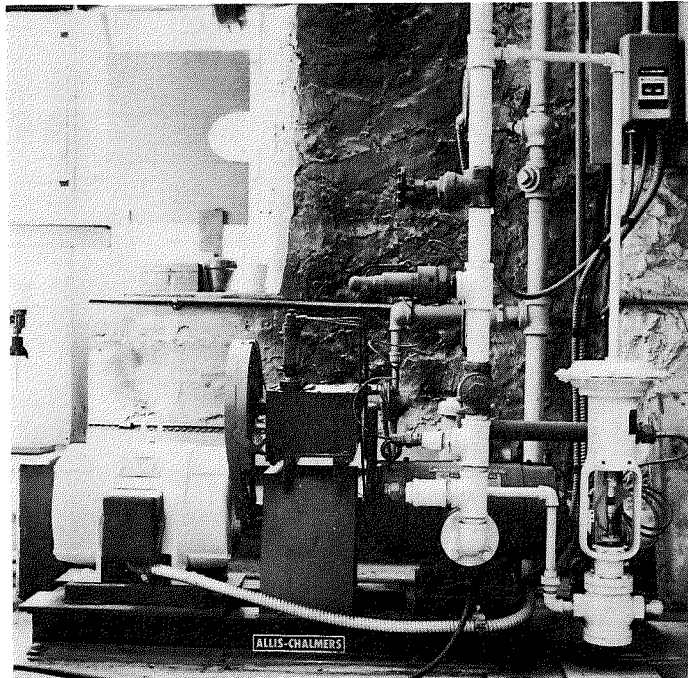

a) Air Compressor

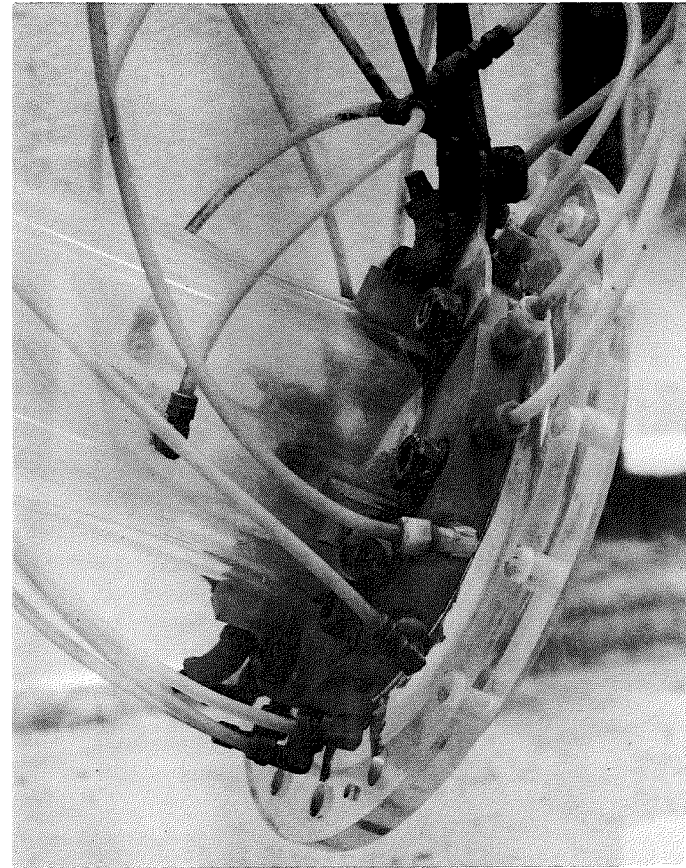

b) Air Injection Manifold

Fig. 4 Photographs of Test Facility



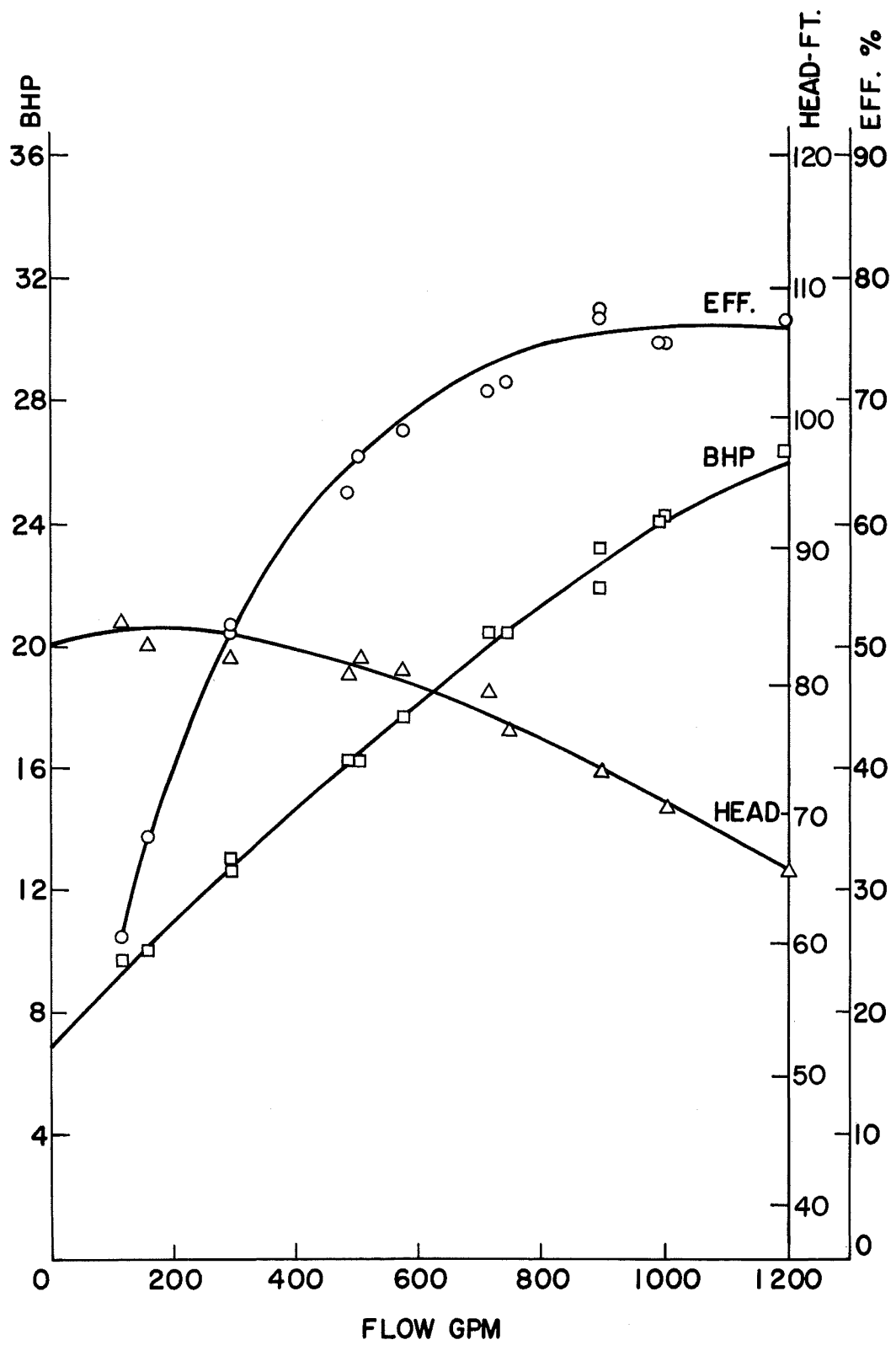

Fig. 5 Pump Characteristics

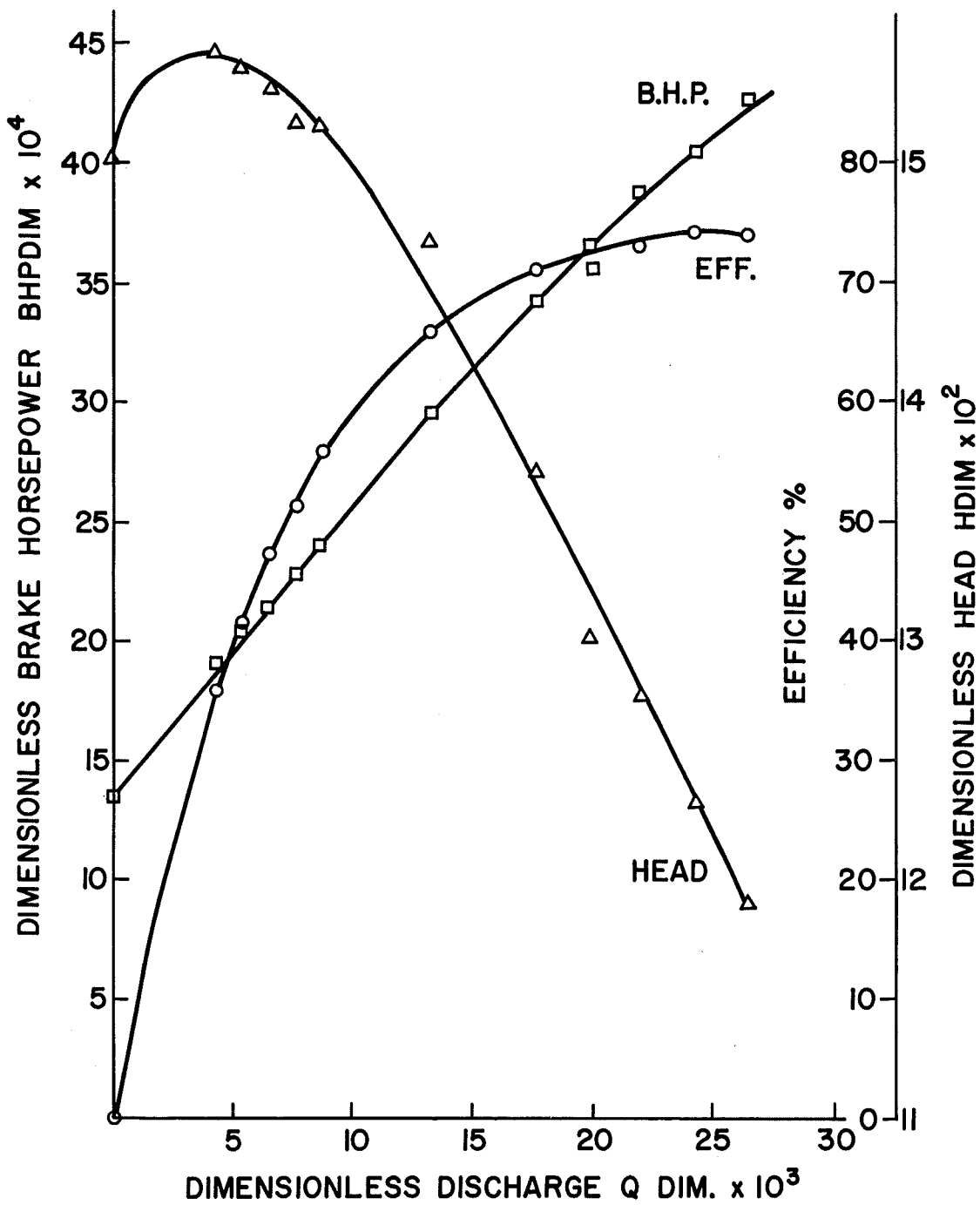
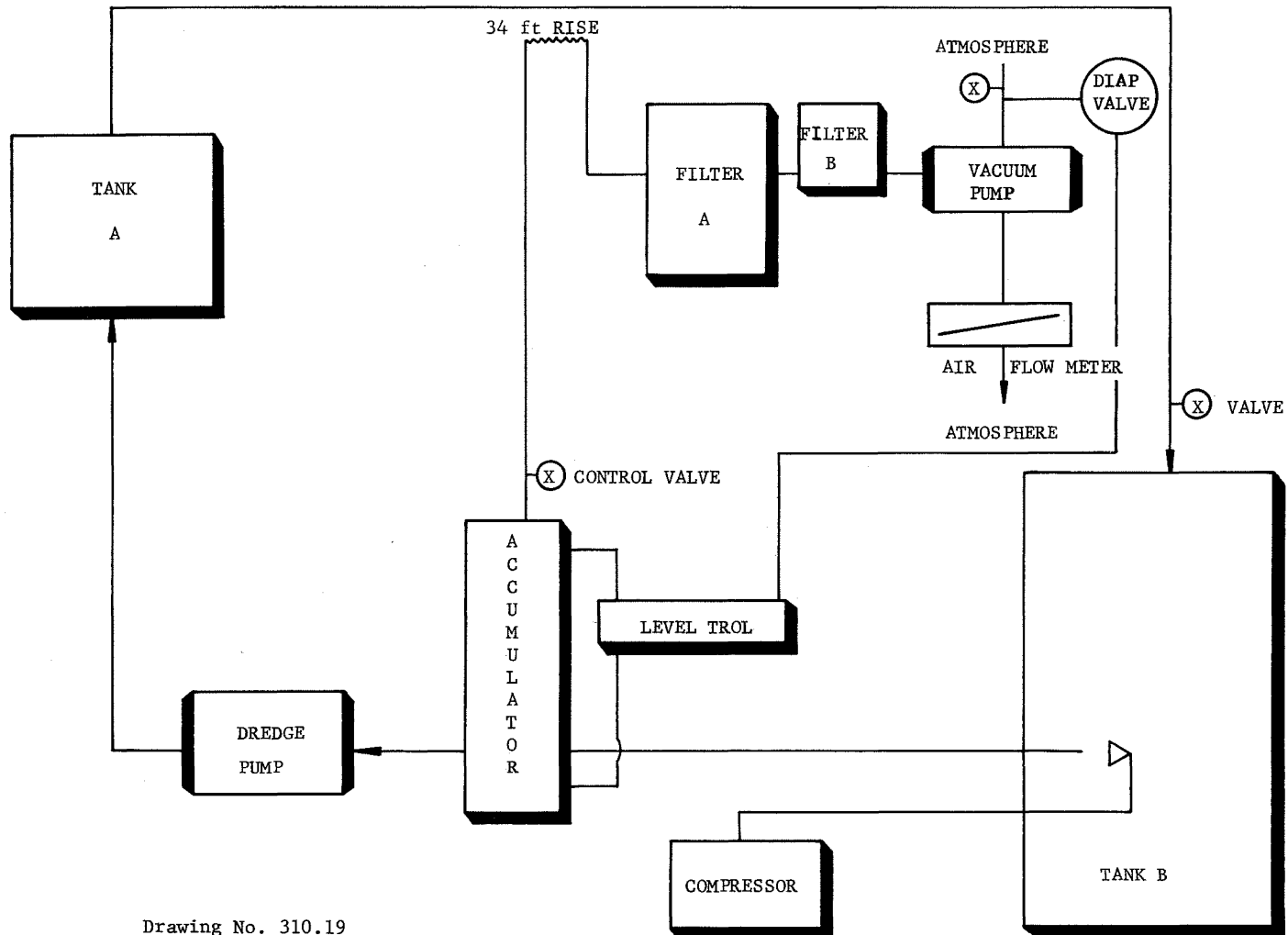
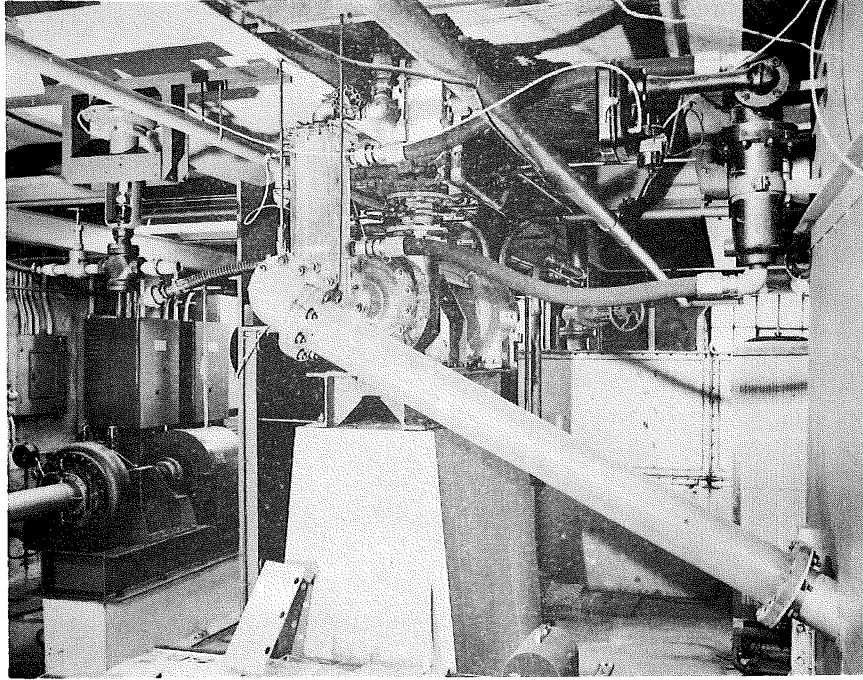

Fig. 6 Dimensionless Pump Characteristics



Drawing No. 310.19

Fig. 7 Schematic Diagram of Facility for Test Series No. 2



a) Accumulator and Level-Trol

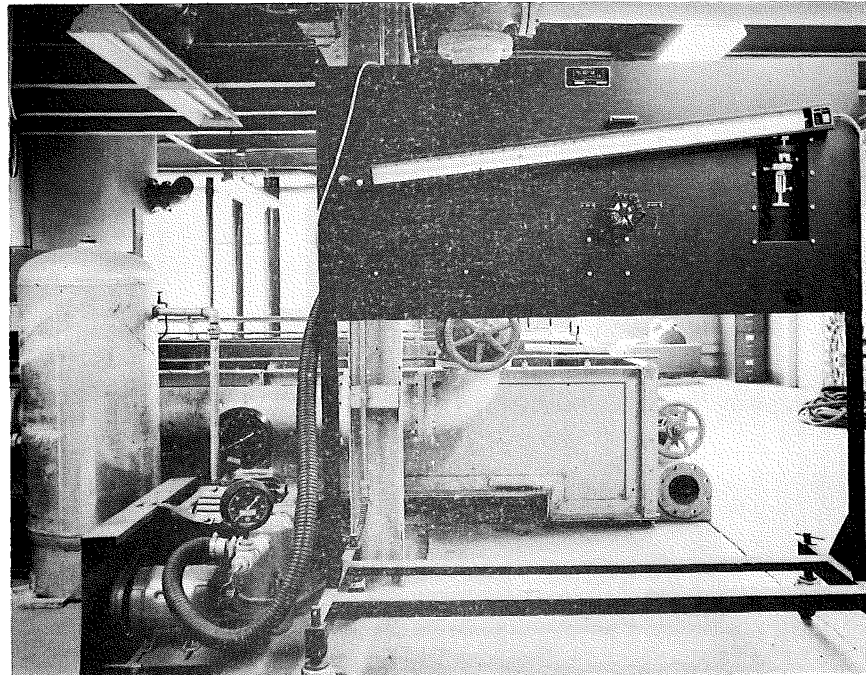

b) Vacuum Pump and Flow Meter

Fig. 8 Photographs of Test Facility

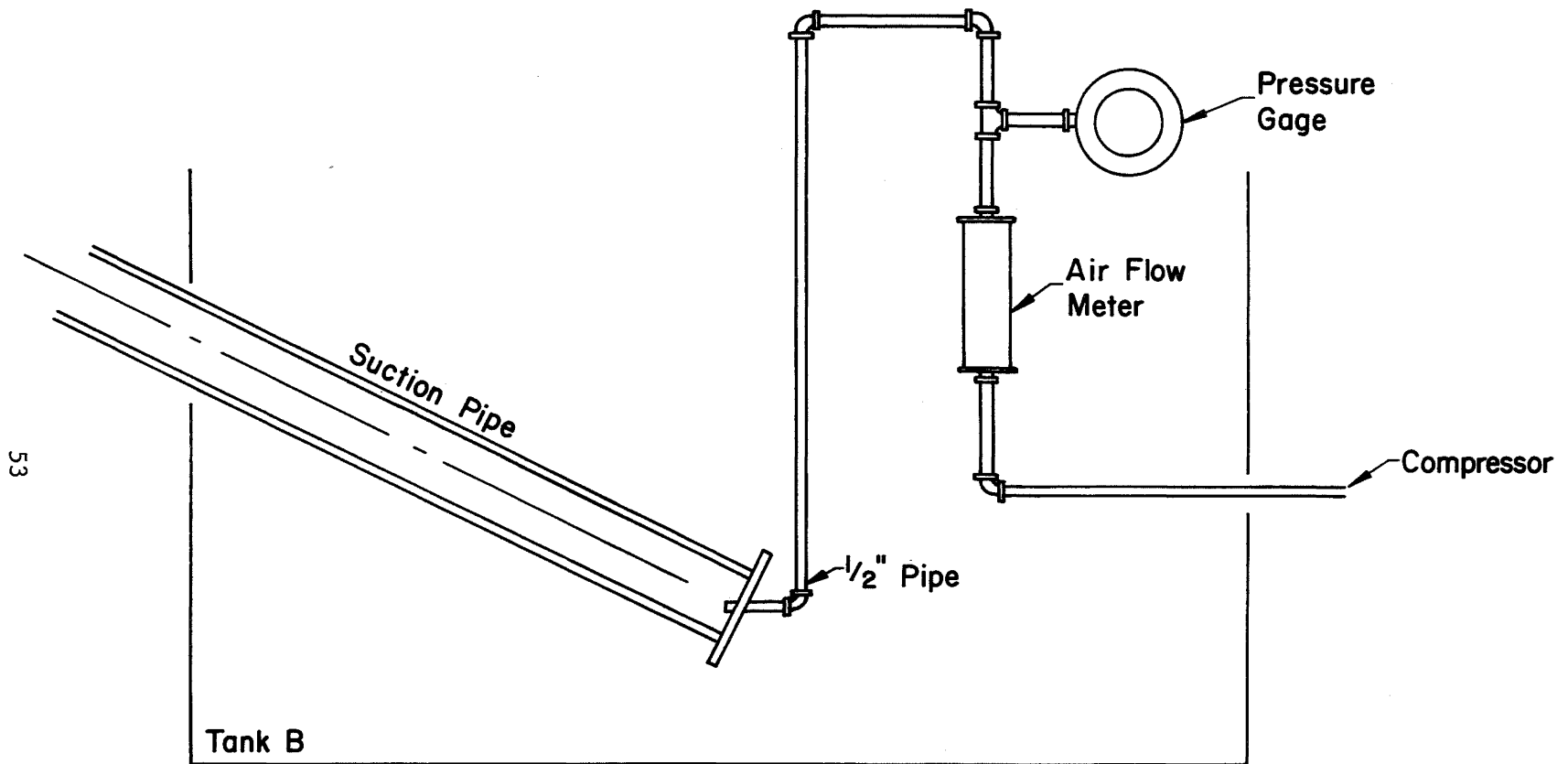

SKETCH OF SINGLE PORT INJECTION SYSTEM

Not to Scale:  
No. 310.20

Fig. 9 Single Port Injection System

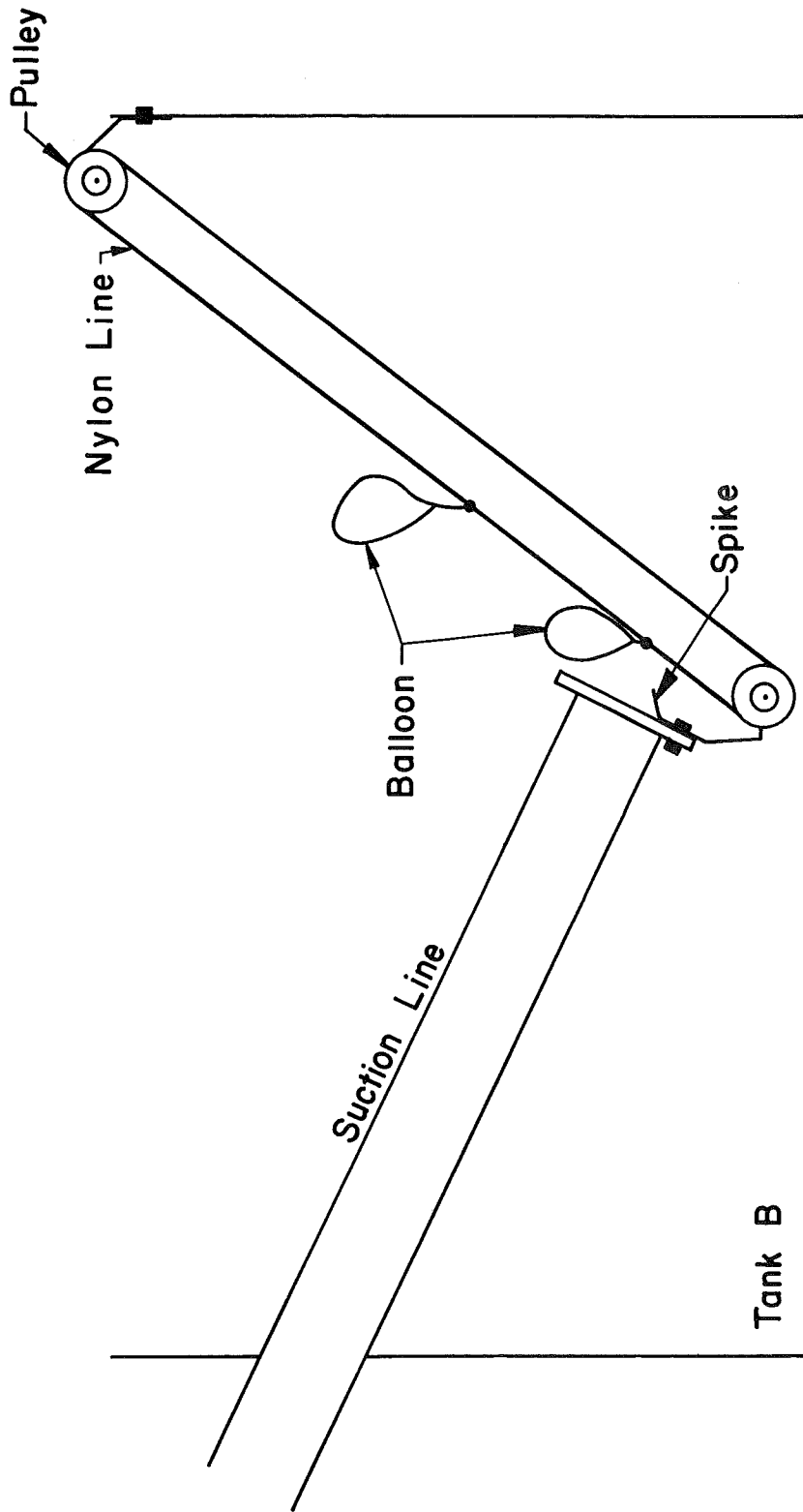

SKETCH OF BALLOON APPARATUS

Not to Scale:  
No. 310.21

Fig. 10 Balloon Air Injection System

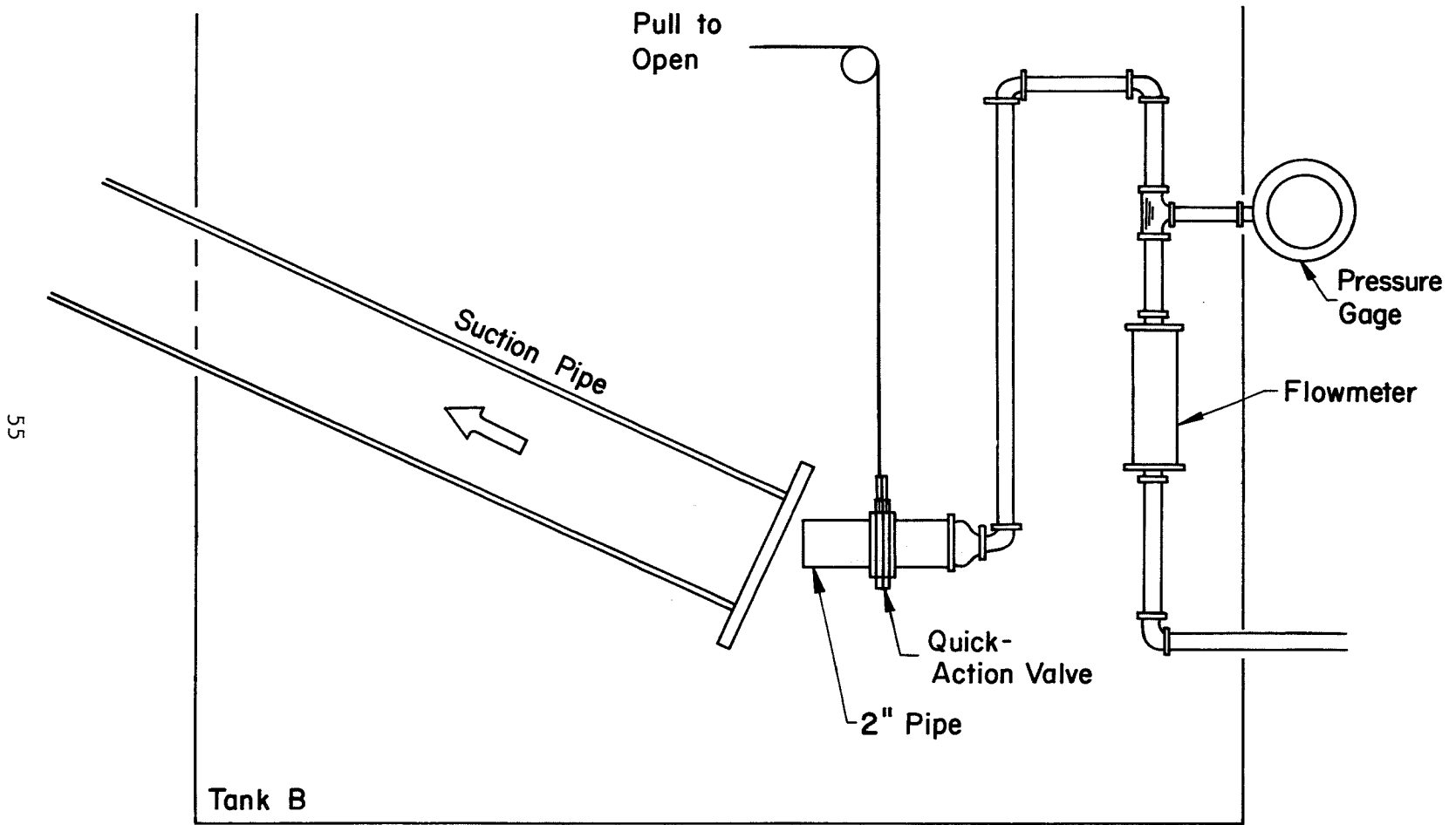

SUBMERGED VALVE INJECTION SYSTEM

No. 310.22

Fig. 11 Submerged Valve Injection System

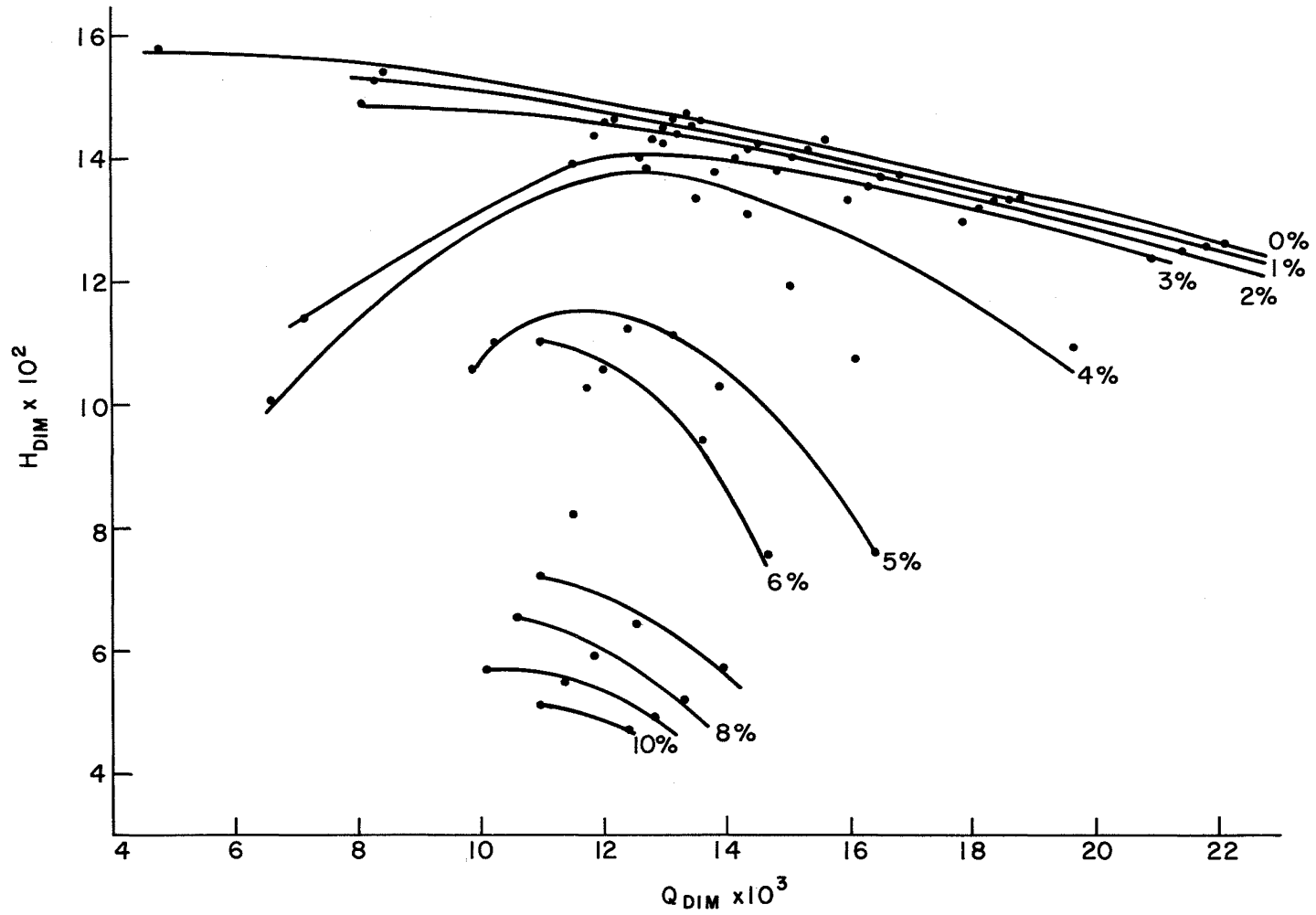

Fig. 12 Test Series No. 1 - Head versus Discharge as Function of Discharge Air Percent



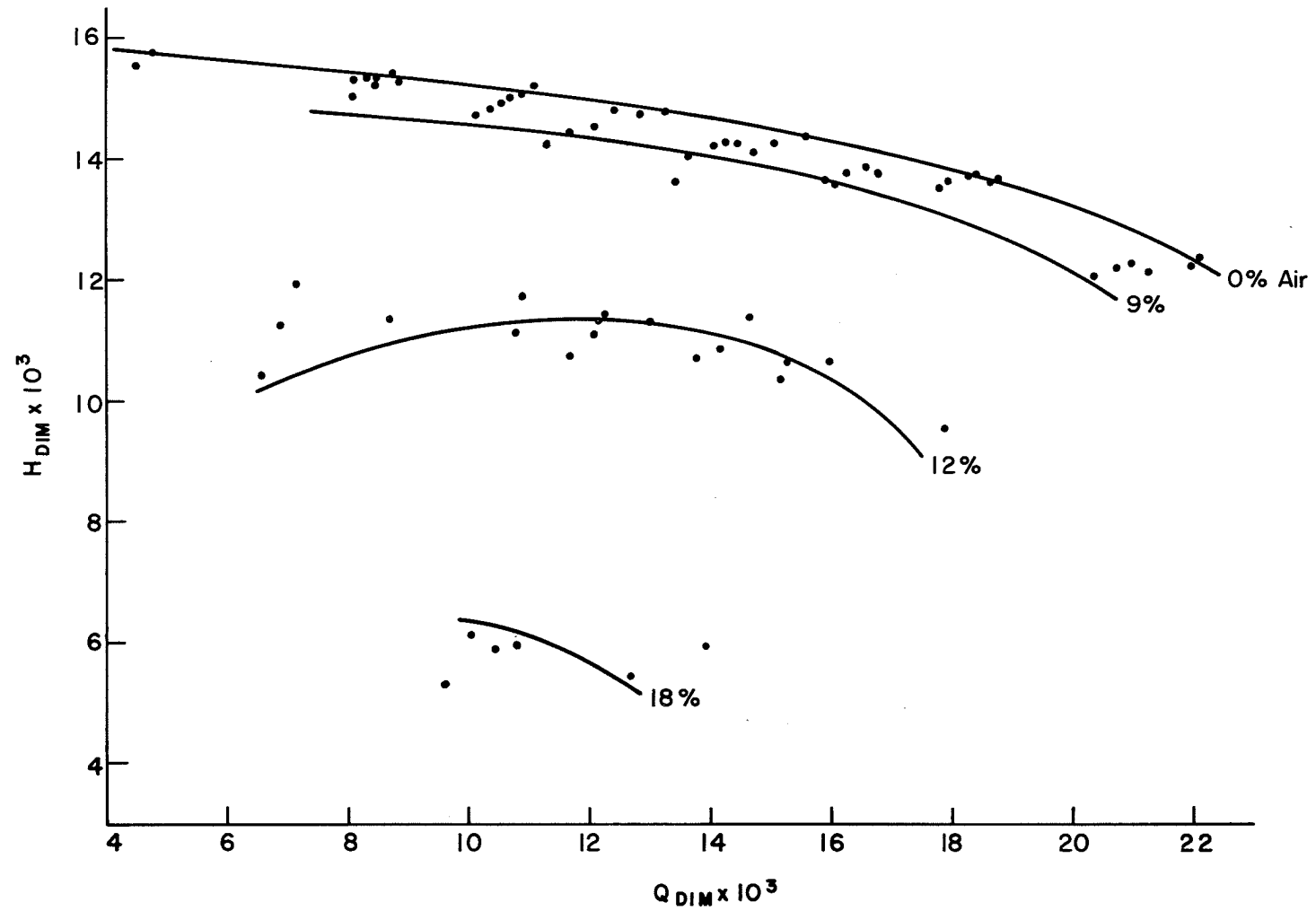

Fig. 13 Test Series No. 1 - Head Discharge as Function of Suction Air Percent

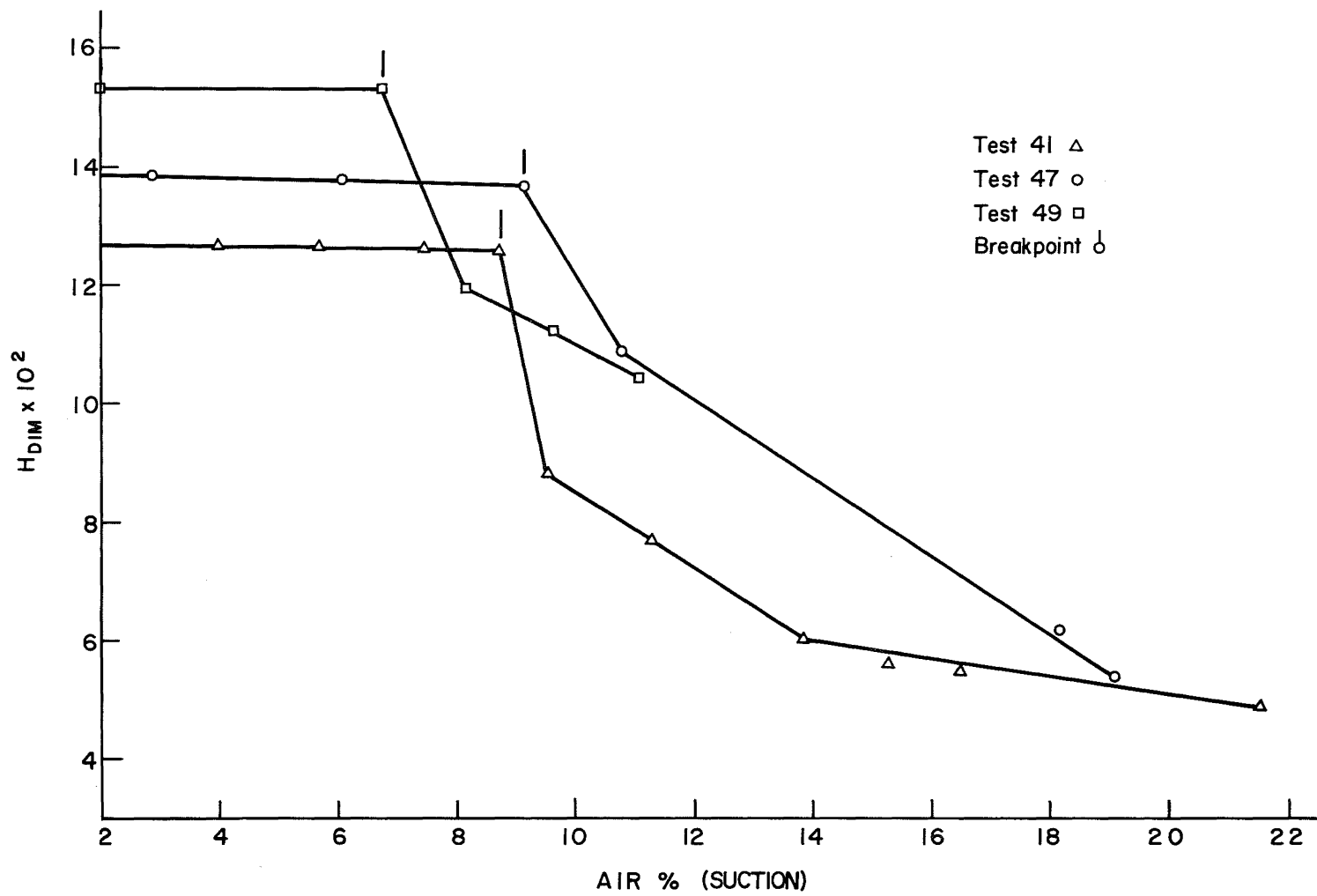

Fig. 14 Head versus Suction Air Percent

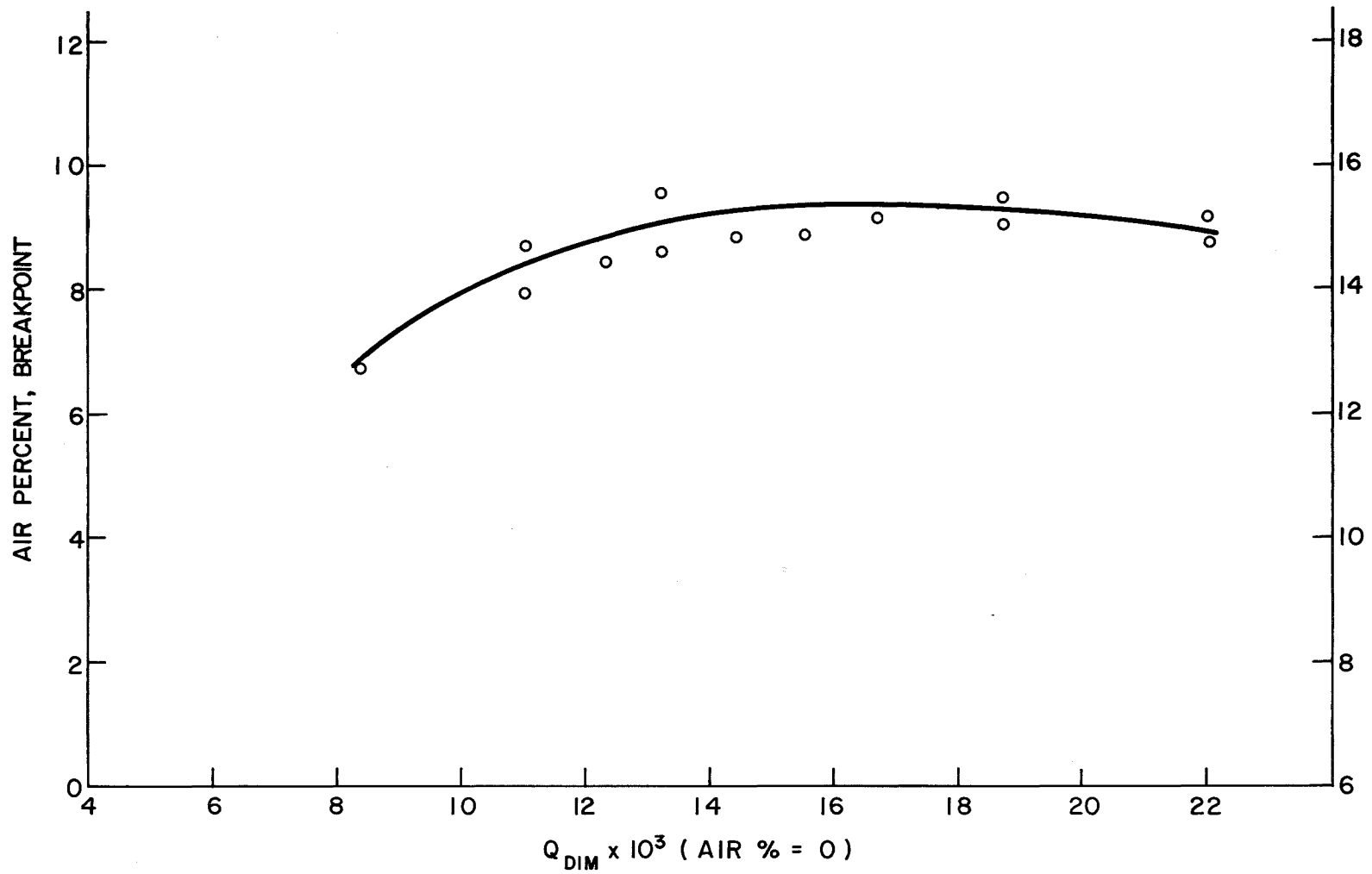

Fig. 15 Air Percent at Break Point versus  $Q_{DIM}$  at Zero Air Percent

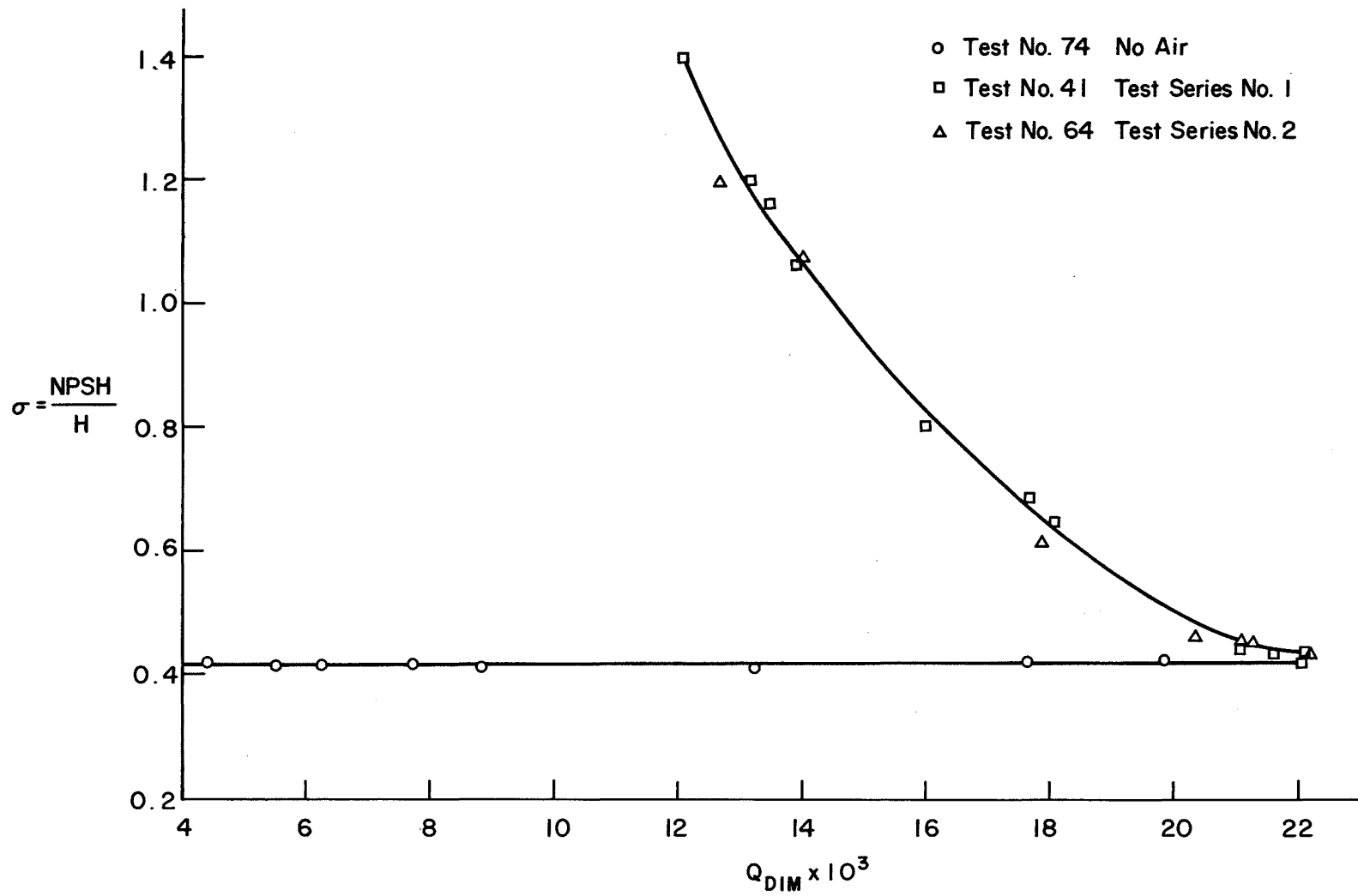

Fig. 16 Net Positive Suction Head versus Dimensionless Discharge

APPENDIX A

NOMENCLATURE

HDIM	dimensionless head, $g^H / (N^2 D^2)$
g	acceleration of gravity ft./sec. <sup>2</sup>
H	total dynamic head, ft. of fluid
N	rotational speed, radians/sec.
D	impeller diameter, ft.
QDIM	dimensionless discharge, $Q / (ND^3)$
Q	discharge, cubic ft./sec.
EFE	efficiency
WHP	water horsepower, $\gamma QH$
$\gamma$	unit weight, pounds per cubic foot
BHP	brake horsepower
gpm	gallons per minute
n	rotational speed, revolutions per minute
SCFM	standard cubic feet per minute
$N_R$	Reynolds number
u	velocity, feet per second
d	pipe diameter
$\rho$	fluid density, slugs/ft. <sup>3</sup>
$\mu$	dynamic viscosity, lb.-sec./ft. <sup>2</sup>
RPM	revolutions per minute
°C	degrees centigrade
psi	pounds per square inch
cfm	cubic feet per minute
cfs	cubic feet per second
p	pressure, pounds per square foot

APPENDIX B  
COMPUTER PROGRAM

SEQ	LABL	TYP	STATEMENT
10	SGU	CRD	RPM, ZO, HSTAR, HAT, HV, ATEMP, WTEMP, N, TEST
11			D = 84
20			RUN = 1
40		PL	PROJECT 310 ARMY PUMP TEST AND AIR PERCENT
50		PVL	TEST, RPM
60	RUS	CRD	QGPMT
70		CRD	HLS, HRS, HL1, HR1, HL2, HR2, AMPS, VOLTS,
71			IAP, U
72			SGS = 13.55
80			QCFST = 2.228E-3*QGPMT
90			BHP = .001167*AMPS*VOLTS
100			SUMH = HL1 + HR1 + HL2 + HR2
110			PDW = .1046*(SUMH - ZO) + .00833*(HR2 - HSTAR)
120			PSW = SGS*(HLS + HRS)/120
130			SAF = UAF*SQRT.((HAT*.4912 + IAP)*11.8/
131			(273 + ATEMP)
140			SAFX = SAF*0.2*(WTEMP + 273)/60
150			DAFCFS = SAFX/(HAT*1.133 + PDW)
151			PAFCFS = SAFX/(HAT*1.133 - PSW)
160			QCFSW = QCFST - DAFCFS
161			SQCFST = QCFSW + PAFCFS
180			VELHS = 1.277*SQCFST*SQCFST
190			VELHD = 2.042*QCFST*QCFST
200			H = PDW + PSW + VELHD - VELHS + 1.07
210			WHP = .11345*QCFSW*H
220			EFF = WHP/BHP
230			HDIM = 27.05E6*H/(RPM*RPM*D*D)
240			QDIM = .846E7*QCFSW/(RPM*D**3)
250			BHPDIM = 2.013E15*BHP/(RPM**3*D**5)
260			NPSH = HAT*1.133 - PSW - HV + VELHS
270			SIGMA = NPSH/H
290			AIRP = 1.67*SAF/QCFSW
291			AIRPD = DAFCFS/QCFSW
292			AIRPS = PAFCFS/QCFSW
300			QRATIO = SQCFST/QCFST
310			WMD = 62.4*QCFSW/QCFST
311			PDWM = PDW*62.4/WMD
312			WMS = 62.4*QCFSW/SQCFST
313			PSWM = PSW*62.4/WMS
320			HM = PDWM + PSWM + VELHD - VELHS + 1.07
321			HDIMM = HDIM*HM/H
325			WHPM = 0.11345*HM*QCFSW
326			EFFM = WHPM/BHP
330		PVL	RUN, QGPMT, BHP, PDW, PSW, VELHD, VELHS, H,
331			WHP, EFF, NPSH, SIGMA, QCFST, QCFSW, SQCFST,
332			DAFCFS, PAFCFS, QRATIO, AIRP, AIRPD, AIRPS,
333			PDWM, PSWM, HM, WHPM, EFFM, HDIM, QDIM, HDIMM
350			RUN = RUN + 1
351			NT = N - RUN (RUS, RUS, SGU)
360		END	END OF PROGRAM

## REFERENCES

1. Herbich, J. B. and W. P. Isaacs  
GAS REMOVAL SYSTEMS PART I: LITERATURE SURVEY AND FORMULATION  
OF TEST PROGRAM, Lehigh University, Fritz Engineering Laboratory  
Report No. 310.3, June, 1964.
2. Shindala, A. and J. B. Herbich  
GAS REMOVAL SYSTEMS PART II: FORMULATION OF TEST PROGRAM  
DEVELOPMENT OF FACILITY LAYOUT, Lehigh University, Fritz Engi-  
neering Laboratory Report No. 310.7, February, 1965.
3. Stepanoff, A. J.  
CENTRIFUGAL AND AXIAL FLOW PUMPS, John Wiley & Sons, New York,  
1957.
4. Bewtra, J. K.  
AIR DIFFUSION STUDIES, Journal of Water Pollution Control  
Federation, Vol. 3 , October, 1964.
5. -----  
LEWIZ PROGRAMMING MANUAL, Lehigh University, Computing Center,  
1963.
6. Miller, R. E., S. C. Ko, and J. R. Adams  
GAS REMOVAL SYSTEM ASSOCIATED WITH DREDGE PUMP: PHASE C,  
Lehigh University, Fritz Engineering Laboratory Report No.  
310.19, April, 1967.