

## Lehigh University Lehigh Preserve

---

Fritz Laboratory Reports

Civil and Environmental Engineering

---

1965

# Gas removal systems, Phase B: part I formation of test program, January 1965

A. Shindala

J. B. Herbich

A. Amatangelo

G. Bagge

Follow this and additional works at: <http://preserve.lehigh.edu/engr-civil-environmental-fritz-lab-reports>

---

### Recommended Citation

Shindala, A.; Herbich, J. B.; Amatangelo, A.; and Bagge, G., "Gas removal systems, Phase B: part I formation of test program, January 1965" (1965). *Fritz Laboratory Reports*. Paper 210.  
<http://preserve.lehigh.edu/engr-civil-environmental-fritz-lab-reports/210>

This Technical Report is brought to you for free and open access by the Civil and Environmental Engineering at Lehigh Preserve. It has been accepted for inclusion in Fritz Laboratory Reports by an authorized administrator of Lehigh Preserve. For more information, please contact [preserve@lehigh.edu](mailto:preserve@lehigh.edu).

FRI-TZ-EN-G-I-N-E-E-R-I-N-G-I-N-G-I-N-I-T-Y  
UN-I-V-E-R-S-I-T-Y  
I-N-S-T-I-T-U-T-E  
O-F  
R-E-S-E-A-R-C-H



Dredge Pump Research

Gas Removal Systems  
Phase B: Part 1  
Formulation of Test Program

by

A. Shindala  
J. B. Herbich  
A. Amatangelo  
G. Bagge

Fritz Engineering Laboratory Report No. 310.6

CIVIL ENGINEERING DEPARTMENT  
FRITZ ENGINEERING LABORATORY

GAS REMOVAL SYSTEMS  
PHASE B: PART 1  
FORMULATION OF TEST PROGRAM  
DEVELOPMENT OF FACILITY LAYOUT

Status Report No. 5

Prepared by

A. Shindala  
J. B. Herbich  
A. Amatangelo  
G. Bagge

Prepared for

U. S. Army Engineer District, Philadelphia  
Corps of Engineers  
Philadelphia, Pennsylvania  
Contract No. DA-36-109-CIVENG-64-72

January 1965

Bethlehem, Pennsylvania

Fritz Engineering Laboratory Report No. 310.6

A B S T R A C T

A revised proposed test program is presented and discussed for carrying out an experimental study of gas removal from dredging suction lines. Two series of tests and the sequence of tests within each series are planned. The parameters to be studied are determined and classified as dependent and independent parameters.

Development of the facility layout, determination of space requirements for both the test facility and the physical arrangement of apparatus, and a list of components needed is also included in this report.

P R E F A C E

The following status report summarizes the studies performed under Part 1, Phase B of the project during the period December 1, 1964 to January 15, 1965, at the Hydraulic and Sanitary Engineering Division of Fritz Engineering Laboratory, under term of Contract No. DA-36-109-CIVENG-64-72. The progress on the study was reported in three status reports dated February 1964, April 1964, and October 1964 (Fritz Laboratory Reports No. 310.1<sup>(1)\*</sup>, No. 310.2<sup>(2)\*</sup>, No. 310.4<sup>(3)\*</sup>, and No. 310.5<sup>(4)\*</sup>).

Phase A of the project was completed and summarized in the project report No. 310.4, dated June 1964.

Dr. John B. Herbich is the Project Director, and Dr. Adnan Shindala is the Project Supervisor. They are assisted by Instructor A. Amantangelo and Research Assistant G. Bagge. Professor W. J. Eney is Head of the Department of Civil Engineering and Fritz Engineering Laboratory, and Dr. L. S. Beedle is the Director of Fritz Engineering Laboratory.

---

\*Numbers in parenthesis refer to references on page 23

LIST OF CONTENTS

	Page
Abstract	i
Preface	ii
List of Contents	iii
List of Figures	iv
I Introduction	1
II Test Setup	3
III Test Program	5
A. Test Series No. 1	5
B. Test Series No. 2	7
IV Facility Layout	10
(a) Equipment Available	10
(b) New Equipment and Items Needed	10
Appendix	15
References	23

LIST OF FIGURES

	Page	
Figure 1	Relative Solubility	16
Figure 2	Proposed Floor Plan for Test Facility	17
Figure 3	Side Elevation-Proposed Test Facility	18
Figure 4	Plexiglas Piping	19
Figure 5	Malleable Iron Piping	20
Figure 6	Bronze-Plexiglas Model Pump Casing	21
Figure 7	Cylinder Accumulator	22

## GAS REMOVAL SYSTEMS

### Proposed Program for Phase C

#### I Introduction

Gases in dredged materials occur in two distinct forms:

(1) As free gas which is usually trapped due to the effect of liquid viscosity and enters the suction line of the pump without opportunity to escape to the atmosphere; and,

(2) As dissolved gas in the liquid but which comes out of solution when the suction pressure is decreased below atmospheric pressure. The volume of dissolved gas coming out of solution in the suction line depends upon the negative or vacuum pressure in that line.

The gases under discussion are the products of decomposition of organic matter in the bottom material. They are dissolved in water forming a part of the in situ material, and, after this solution is saturated, bubbles form throughout the material. From analysis of these gases, it was ascertained that the most soluble gas which might be encountered in dredged materials would be a combination of 85 per cent methane ( $\text{CH}_4$ ) and 15 per cent carbon dioxide ( $\text{CO}_2$ ).

As part of phase B of the project, carbon dioxide ( $\text{CO}_2$ ) and air were both investigated from the standpoint of their solubility in water as well as economy. Air is favored for the following reasons:

1. The solubility of air at different pressures was found to be very close to that of methane (the gas that constitutes 85 per cent of the dredge material gas) whereas carbon dioxide was found to have a much higher solubility than methane (Figure 1).



2. Air is much more economical to use than carbon dioxide.

So, on the basis of the above considerations air was selected as the gas to be used throughout this research.

#### Method of Injection

In the laboratory, the following procedures could be used to introduce air into the suction line of the dredge pump:

(1) A high percentage of air in solution with water under a hydrostatic head could be released in the suction line by decreasing the pressure, or,

(2) A controlled rate of free air could be directly injected into the suction line.

It is believed that the first procedure will significantly complicate monitoring both the amount of air liberated and the total flow of air, which will result in less accurate results. Consequently the second procedure is recommended, and free air will be injected at a point directly downstream from the orifice plates. The air will be supplied by a compressor, and its quantity will be controlled by a pressure regulator, a valve, and a flow meter.

## II Test Setup

The test model facility is designed to simulate the prototype conditions as closely as possible. The drag head will not be used and will be replaced by a set of orifice plates having a range in size and secured at the entrance to the suction pipe. Air will be injected at a point directly downstream from the orifice plate. The suction pressure as well as the flow of water (gpm) will then be controlled by the size of the orifice and the rate of gas injection. A cylindrical accumulator will be used and will be placed at a fixed position determined according to ESSAYONS' setup. The evacuators to be tested with the gas-removal system will include vacuum pumps and water ejectors. The liquid level in the accumulator will be controlled either by Level Trol or vacuum control. The discharge (gpm) will be measured by the orifice at the entrance to the suction line whereas the air content will be measured by a flow meter. A magnetic flowmeter at the discharge side of the dredge pump will be used to measure the combined air-water flow.

The water will be dredged from an open volumetric tank and will be discharged into a closed volumetric tank (Figure 2 ). In order to insure continuous flow, the pressure in the discharge tank will be maintained at one pound per square inch above the atmospheric pressure. The discharge and suction tanks will be connected by a 12-inch pipe equipped with a gate valve for controlling the flow. The pressure at the discharge tank, approximately 50 psia, will be reduced to about 15.7 psia in order to simulate the actual dredging conditions. The excess free air, not removed by the accumulator, will be collected in the discharge tank from where it will be evacuated and passed through an air

flowmeter. The two-tank arrangement is selected because it will allow monitoring the amount of air that will go in or out of solution in the suction line by means of the following mass balance: amount of air introduced into the suction line = amount of air removed by the accumulator + the amount of air removed from the discharge tank,  $\pm$  amount of air going into or out of solution.

The following model test setup is presented in general form:

- (1) Dredge pump, bronze-plexiglas volute casing
- (2) Cylindrical accumulator, transparent
- (3) Accumulator evacuators:
  - (a) Vacuum Pump
  - (b) Water ejector and water pump
- (4) Suction piping, transparent
- (5) Discharge piping, steel with small plexiglas sections
- (6) Suction volumetric tank
- (7) Discharge volumetric tank
- (8) Orifice plates
- (9) Air compressor
- (10) Air flowmeter
- (11) Measuring equipment
  - (a) Vacuum: vacuum gauges
  - (b) Pressure: pressure gauges
  - (c) Speed: strobotac and tachometer
  - (d) Rate of flow of air-water mixture: magnetic flowmeter
- (12) Accumulator: water-level control device
  - (a) level Trol
  - (b) Vacuum control

### III TEST PROGRAM

#### A. Test Series No. 1

In the first test series of this study, general observation will be made of air injected at a controlled rate just downstream the orifice plate into the suction line. The accumulator, vacuum pump, and control equipment will not be used in this series.

##### 1. Objectives: The main objectives of this series will be:

(a) To study the general behavior of the air in the suction system with clear water as the fluid medium; this will include the rise, expansion, and position, of the gas bubbles as they proceed through the suction line;

(b) To provide a reference for comparing the performance of the system with and without the gas removal equipment; and,

(c) To determine the relationship between the gas, pump speed, and suction geometry that will cause a complete collapse, if any, of the dredge pump.

##### 2. Parameters

(1) Gas content (cfs)

(2) Speed (rpm)

(3) Suction geometry

##### 3. Procedure

(1) Operate the dredge pump at a selected speed and with a particular size of orifice.

(2) Inject air into the suction line at a point directly downstream of the orifice plate at a certain rate.

(3) Observe the action, such as rise, expansion, position, and size of the gas bubbles in the suction system in transient and steady flow using strobotac and motion pictures.

(4) Note gauge readings of control parameters, such as voltage, amperage, velocity, pressure, and discharge.

(5) Hold speed and orifice size constant and repeat steps 3 and 4 for different gas content. Note the amount of gas which causes complete collapse, if any, of dredge pump suction for the particular speed and orifice size.

(6) Hold orifice size constant and repeat program for different speeds\*

(7) Repeat program for different orifice plates\*\*.

#### Analysis

(1) Obtain performance (gpm) of the system for each orifice plate at different speeds and gas content.

(2) Plot discharge (gpm) as a function of gas content for a particular orifice plate at different speeds.

(3) Make similar plots for other sizes of orifice plates.

(4) From the above curves, determine the relationship between gas content, speed, and suction geometry that will result in the lowest as well as the highest performance of the system.

\*At least 3 pump speeds will be used

\*\*At least 3 orifices will be used.

## B. Test Series No. 2

In this series, the program of Test Series No. 1 will be repeated but with the accumulator in operation. The position of the accumulator will be fixed according to the ESSAYONS setup. Air will be injected at a point directly downstream from the orifice plate. The performance of two types of evacuators, vacuum pump and water ejector, will be tested. The test will first be performed with a constant liquid level in the accumulator and then repeated with the liquid level in the accumulator permitted to fluctuate. Level Trol or vacuum control will be used to control the liquid level in the accumulator.

Objectives: The objectives of this series will include:

- (1) To determine the effect of the following parameters on the performance of the gas removal system,
  - (a) Gas content (cfs)
  - (b) Suction geometry,
  - (c) Speed (rpm)
- (2) To compare between the effect of two types of evacuators, on the performance of the gas removal system:
  - (a) Vacuum pump
  - (b) Water ejector
- (3) To compare between a constant and fluctuating water level in the accumulator on the performance of the gas removal system.

## Procedure

- (1) Place the cylindrical accumulator in place and connect to the vacuum pump.

- (2) Operate the dredge pump
- (3) Operate the vacuum pump
- (4) Control the vacuum to keep the height of the liquid level in the accumulator constant.
- (5) Repeat program of Test Series No. 1 with the accumulator in operation.
- (6) Repeat above program with the liquid level in the accumulator fluctuating.
- (7) Repeat above program with the accumulator connected to water ejector instead of the vacuum pump.

#### Analysis

- (1) Obtain the performance (gpm) of the system for each orifice plate at different speeds and gas content using the vacuum pumps and constant water level in the accumulator
- (2) Plot the discharge (gpm) as a function of gas content for a particular orifice plate at different speeds
- (3) Make similar plots for different orifice plates
- (4) Repeat above analysis using the vacuum pump but with a fluctuating water level in the accumulator.
- (5) Repeat above analysis using the water ejector instead of the vacuum pump.
- (6) Compare the results obtained under Test Series No. 2 with those obtained under Test Series No. 1.
- (7) Compare the results obtained under Test Series No. 2 for the two cases of water level control for both the vacuum pump and the water

ejector.

(8) Compare the results obtained under Test Series No. 2 for the vacuum pump with those of the water ejector.



#### IV FACILITY LAYOUT

##### (a) Equipment available in the Hydraulic Laboratory

- (1) Dredge pump without volute casing
- (2) Magnetic flowmeter
- (3) Strobotac
- (4) Tachometer
- (5) 40-hp D. C. motor
- (6) Two volumetric tanks, A and B, (Figures 2 and 3)
- (7) Bearings
- (8) Dynalog recorder
- (9) 50-inch manometer
- (10) Two 100-inch manometers

##### (b) New Equipment and Items Needed

- (1) Dredge pump casing, bronze-plexiglas (see Figure 6)
- (2) Cylinder accumulator, plexiglas (Figure 7)
- (3) Four-orifice plates
- (4) Four Mechanipak seals with style B ceramic stationary seat and vibration ring B-T966-16, for 2-1/4 inch shaft
- (5) Plexiglas tubing for the suction side (Figure 4)
  - (a) 12.0 ft. of (5-1/2 in. O.D. and 4-1/2 in. I. D.)
  - (b) 2.0 ft. of (7 in. O. D. and 6 in. I. D.)
  - (c) One elbow (5-1/2 in. O. D. and 4-1/2 in. I. D.)
- (6) Plexiglas flanges (Figure 4)
  - (a) Two flanges (7 in. O. D. and 6.0 in. I. D.)
  - (b) Ten flanges (5-1/2 in. O. D. and 4-1/2 in. I. D.)

- (7) Plastic sheets for the suction tank
  - (a) Two sheets (3/4 by 60 by 72 in.)
- (8) Steel piping. (Figure 5)
  - (a) 15 ft. of (6 in. I. D.)
  - (b) 1 ft. of (4-1/2 in. I. D.)
  - (c) 13 ft. of (12 in. I. D.)
  - (d) 1 ft. of (4 in. I. D.)
- (9) Steel flanges (Figure 5)
  - (a) Two 12 in. flanges
  - (b) Seven 6 in. flanges
  - (c) Two 4-1/2 in. flanges
  - (d) Three 4 in. flanges
- (10) Steel elbows (Figure 5)
  - (a) Three 6 inch elbows
  - (b) One 6 by 4 inch elbow
- (11) Victaulic couplings (Figure 5)
  - (a) Two-12 inch couplings
  - (b) Six-6 inch couplings
- (12) Gate valves (Figure 5)
  - (a) One-6inch gate valve
  - (b) One-12 inch valve
- (13) Structural steel for pump foundation and support
  - (a) 20 ft. 6 in. channel
  - (b) 4 ft. 8 in. channel
  - (c) 10 ft. 6 in. I section
  - (d) 7 ft. 4 in. I section
  - (e) 42 ft. (3 by 3 by 1/4 in. angle)

## (14) Extension of discharge tank

## Plates

- (a) One plate (1/4 by 67-3/8 by 48 in.)
- (b) One plate (1/4 by 69-1/2 by 48 in.)
- (c) One plate (1/4 by 71-1/4 by 48 in.)

## Baffles

- (a) One baffle (1/4 by 66 by 48 in.)
- (b) One baffle (1/4 by 72 by 48 in.)

## Angle

- (a) 16 ft. angle (2-1/4 by 2-1/4 by 1/4 in.)

## (15) Extension of suction tank

## Plates

- (a) Two plates (18 by 48 by 1/4 in.)
- (b) Two plates (18 by 120 by 1/4 in.)

## (16) Concrete for pump foundation (Figure 3)

- (a) 2.0 cubic yards

## (17) Measuring devices

## Manometers

(a) Five Meriam Model 10AA25 WM manometers, 50 in. range, scale A, 303 stainless steel wetted parts, wall mounting.

(b) One - Meriam model 20AA25 manometer, 100 inch range, scale A, stainless steel wetted parts, wall mounting.

(c) Five lbs. Meriam Hi-purity mercury, sp. gr. of 13.57,

0-2913

(d) Five pt. Meriam D-7878 fluid, sp. gr. of 1.20

- (e) Thirty-four Nylo connectors, 268-N, 1/4 in. O. D.
- (f) Twenty Nylo elbows, 269-N, 1/4 in. O. D.
- (g) Twenty Nylo tees, 272-N, 1/4 in. O. D.
- (h) Twenty two-way shut-off valves, 31-E

Pressure and vacuum gauges

- (a) One (0-2 psig) range pressure gauge
- (b) 2-30 in. vacuum gauge

Thermometers

- (a) 3-0<sup>o</sup> -100<sup>o</sup> C range), 24 in. long, M354, thermometer

(18) Air:

- (a) Air compressors 10 hp motor
- (b) Pneumatic operated pressure regulator
- (c) Air filter
- (d) Motor starting switch-magnetic 3 phase
- (e) Electrical wiring and installation
- (f) 3 - Air flow meters

(19) Pressure regulator at the discharge tank

(20) Air-controlled valve for the accumulator

(21) Level Trol

(22) Vacuum pumps

(a) One-single stage rotary vacuum pump, 3 hp. (for the accumulator)

(b) One-1/3 hp. vacuum pump (for discharge tank)

(c) Pneumatic operated vacuum breaker control valve

(23) Water ejector

(24) Water pump

(25) Movie films and processing

(a) 150 - Dupont high-speed reversal pan type 931 film and processing

(b) 50 - 100 ft. roll black and white 16mm movie films and processing

(26) 4 - gallons of protective paint

(27) 10 hours of computer time for data processing

(28) Labor for calibration of flow meter

(29) Labor for electrical installation

(30) Dynalog paper

(31) Shipping cost

A P P E N D I X

i

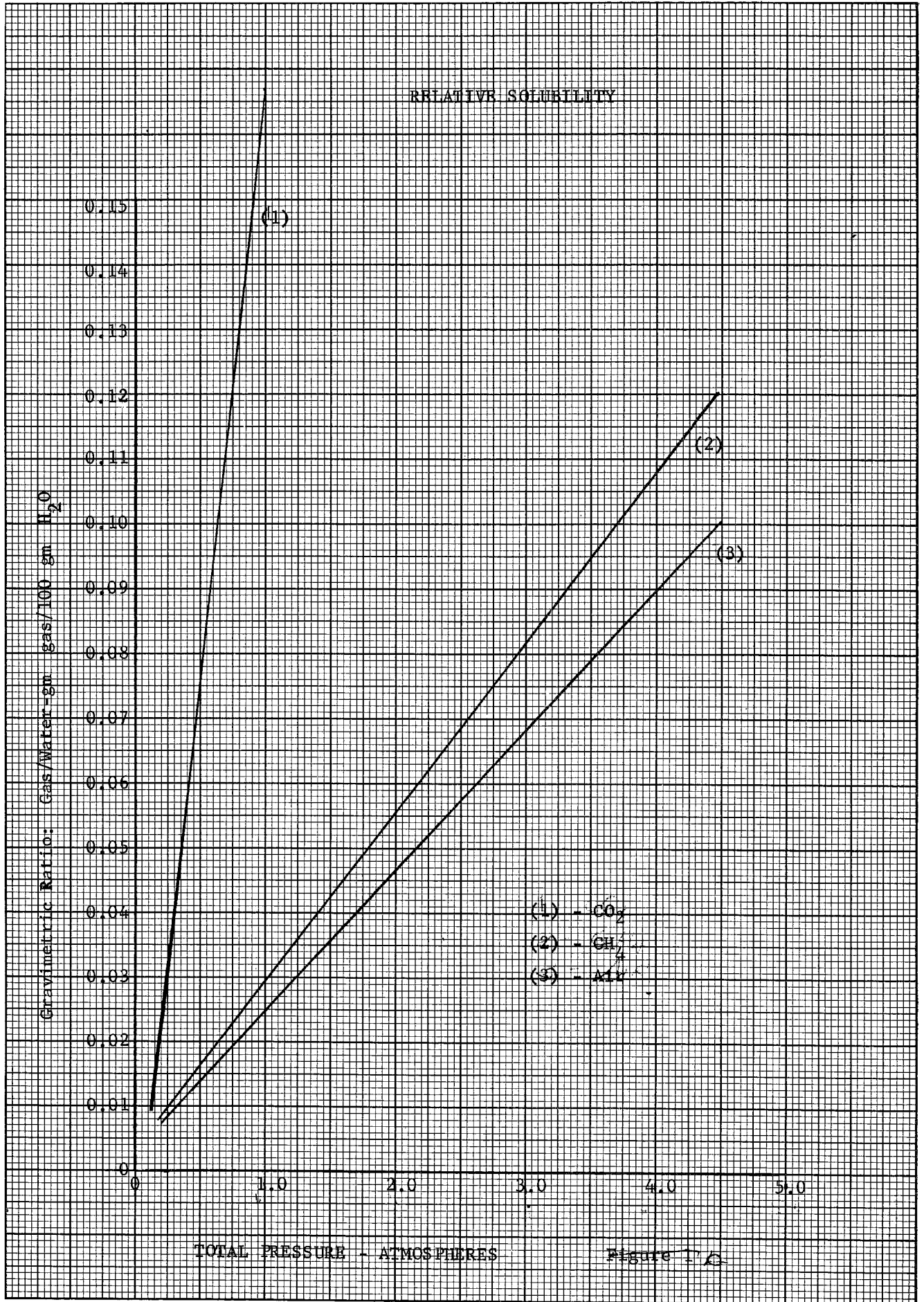

Figure 1.2

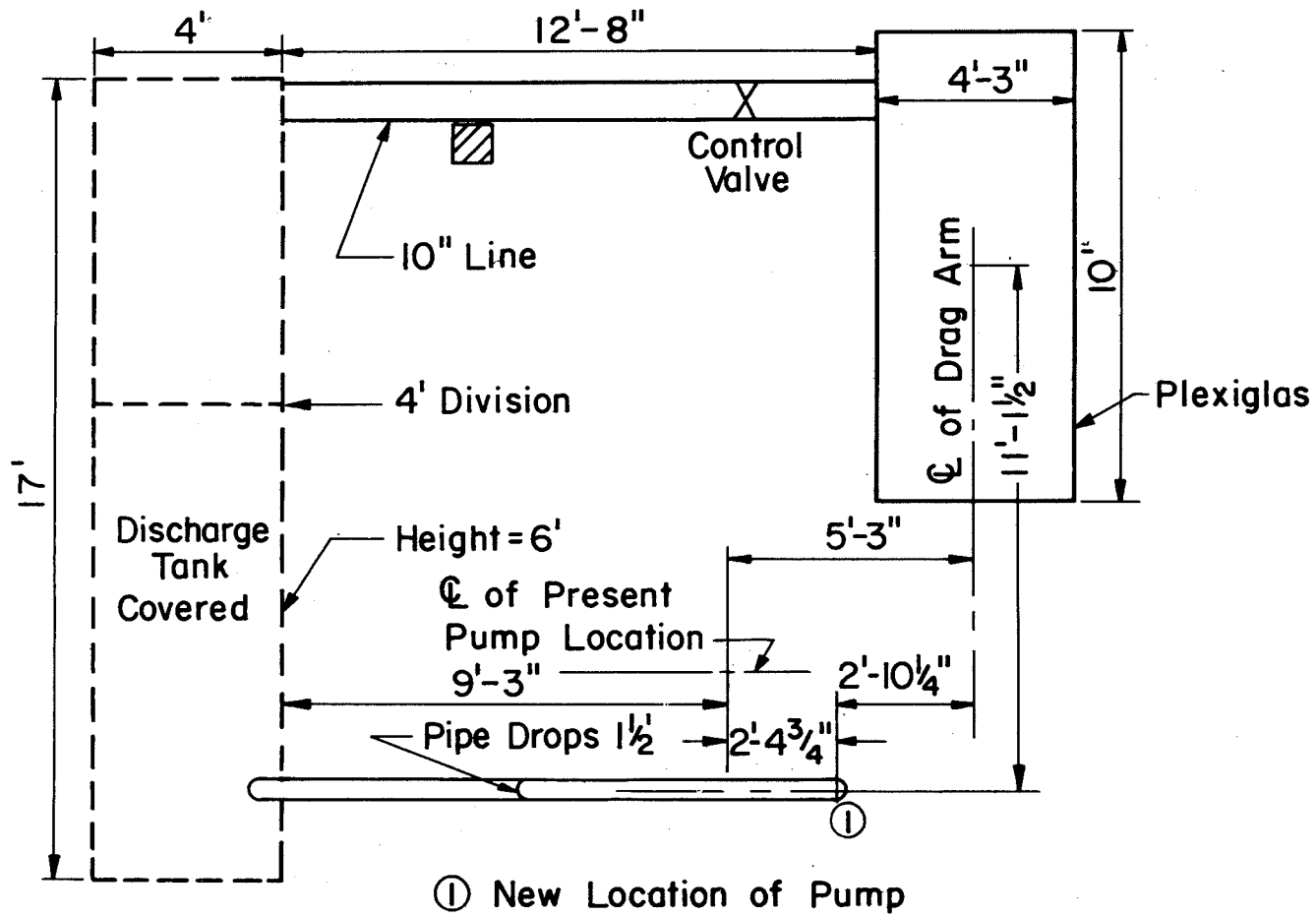

Figure 2 Proposed Floor Plan for Test Facility

Scale  $\frac{1}{4}'' = 1'$   
 Drawing No. 310.6



- Note: ① Possible Locations of Discharge Tank  
 ② Supply Tank with Plexiglas Side

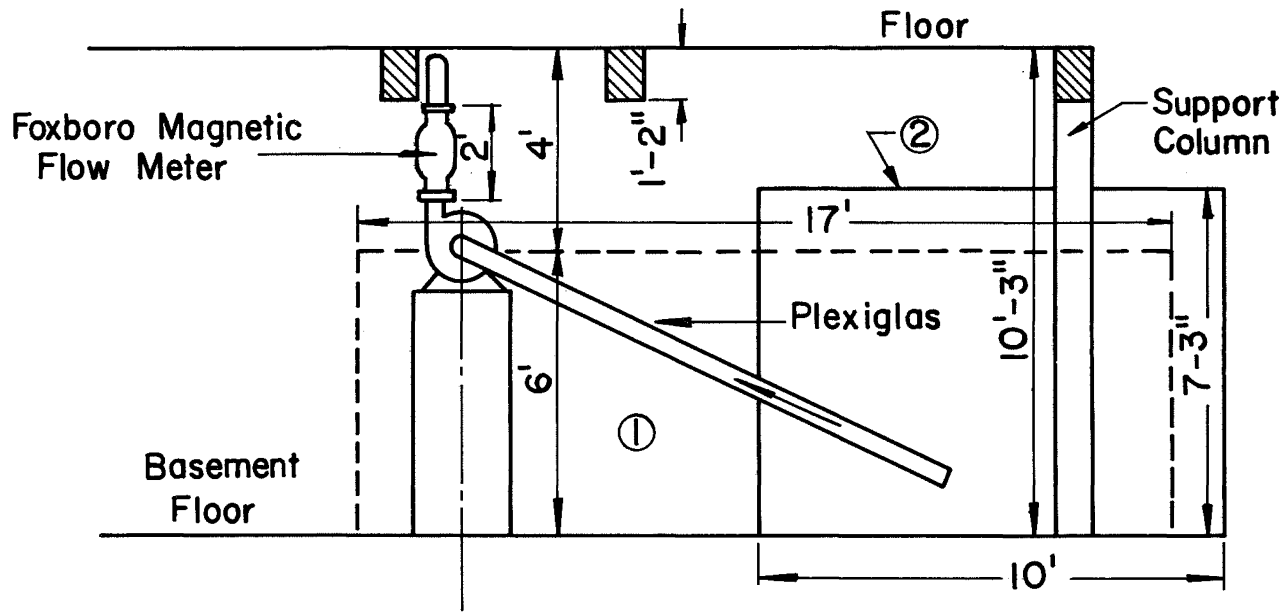
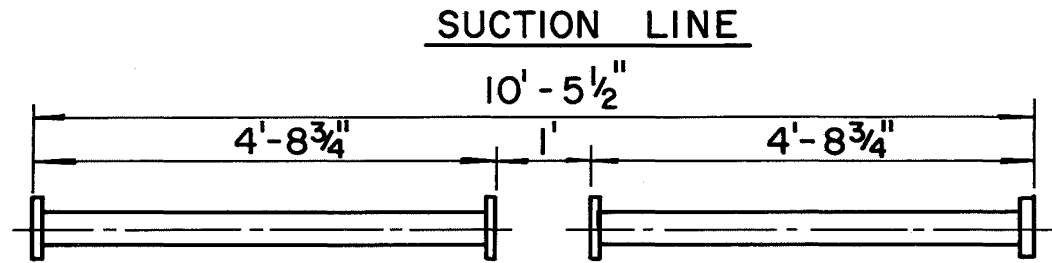
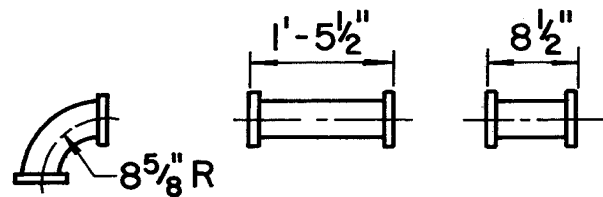

Figure 3 Side Elevation-Proposed Test Facility

Scale  $\frac{1}{4}'' = 1'$   
 Drawing No. 310.7



Suction Line - All Inside Diameters = 4 $\frac{1}{2}$ " ,  $\frac{1}{2}$ " Wall Thickness



DISCHARGE LINE

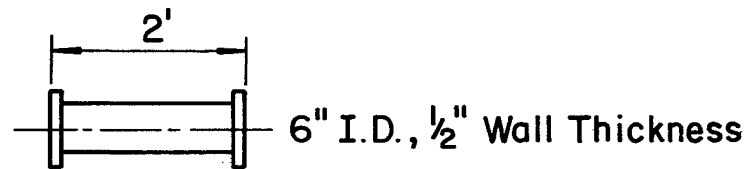

Scale  $\frac{1}{2}$ " = 1'  
 Drawing No. 310.8

Figure 4 Plexiglas Piping

- ① 1- 6" Gate Valve - 7<sup>3</sup>/<sub>4</sub>" Long W/Flange
- ② 1- 10" Gate Valve - 13" Long
- Ⓥ Indicates Victaulic Coupling

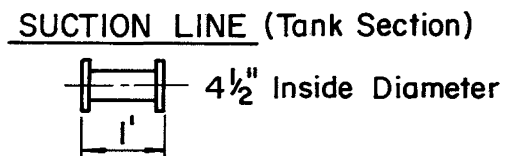
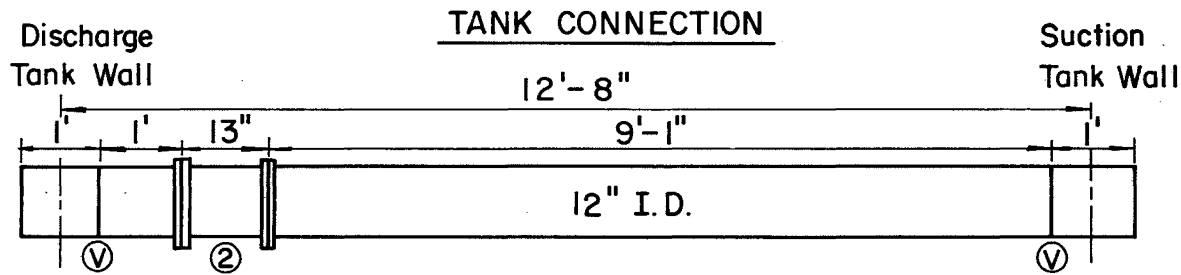
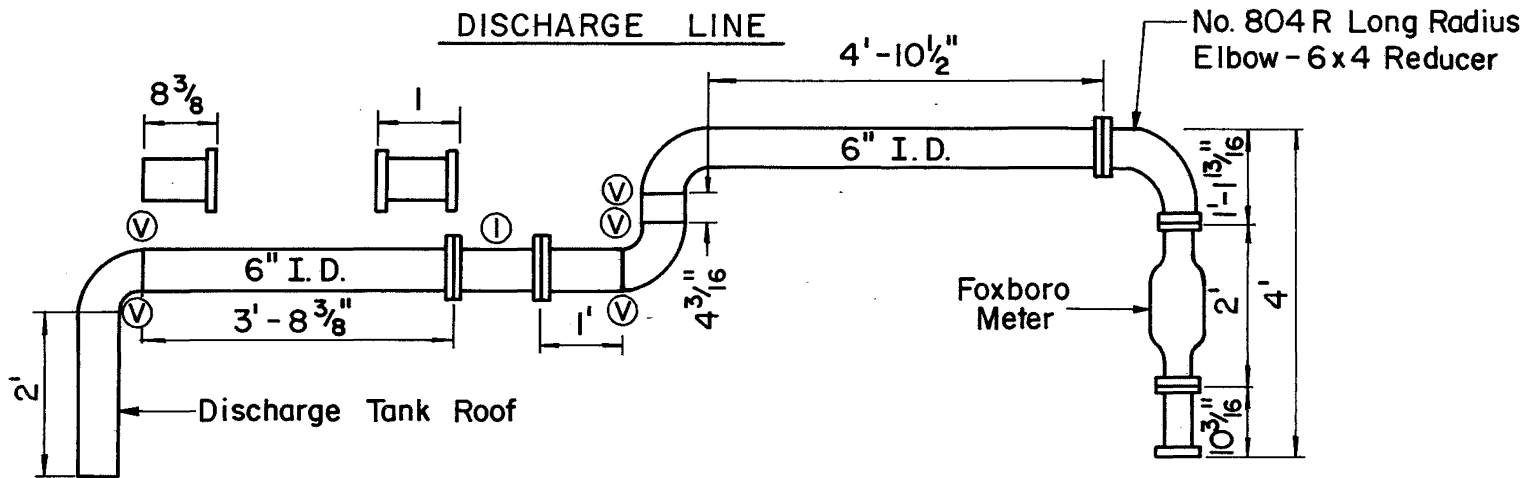

Note - To Be Modified According To The Essayon's

Scale 1/2" = 1"  
Drawing No. 310.9

Figure 5 Malleable Iron Piping

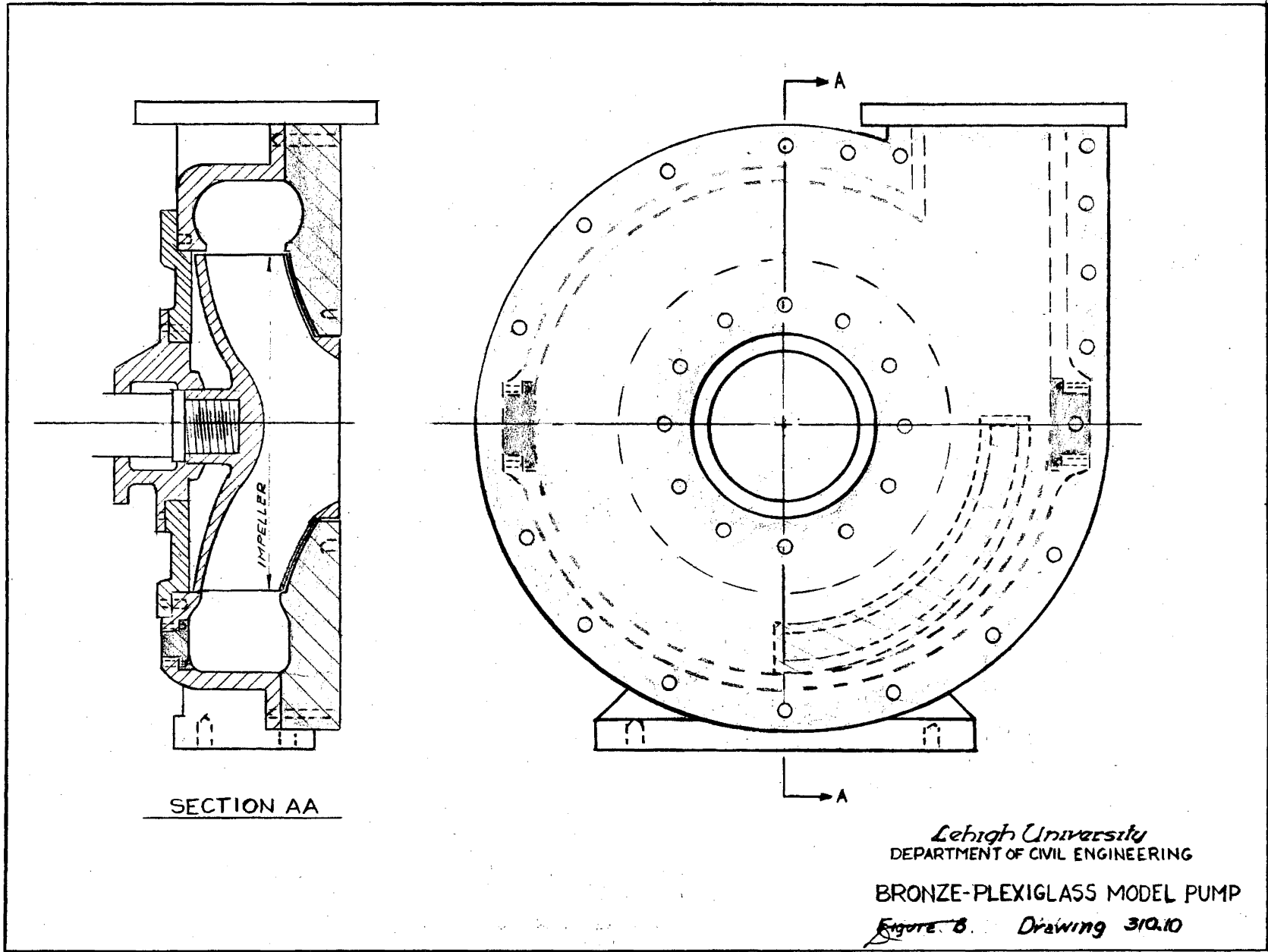

Figure 6

Bronze-Plexiglas Model Pump Casing

Lehigh University  
DEPARTMENT OF CIVIL ENGINEERING

# CYLINDER ACCUMULATOR

DRAWING 310.3

SCALE 1:2 ALL DIM. IN INCHES

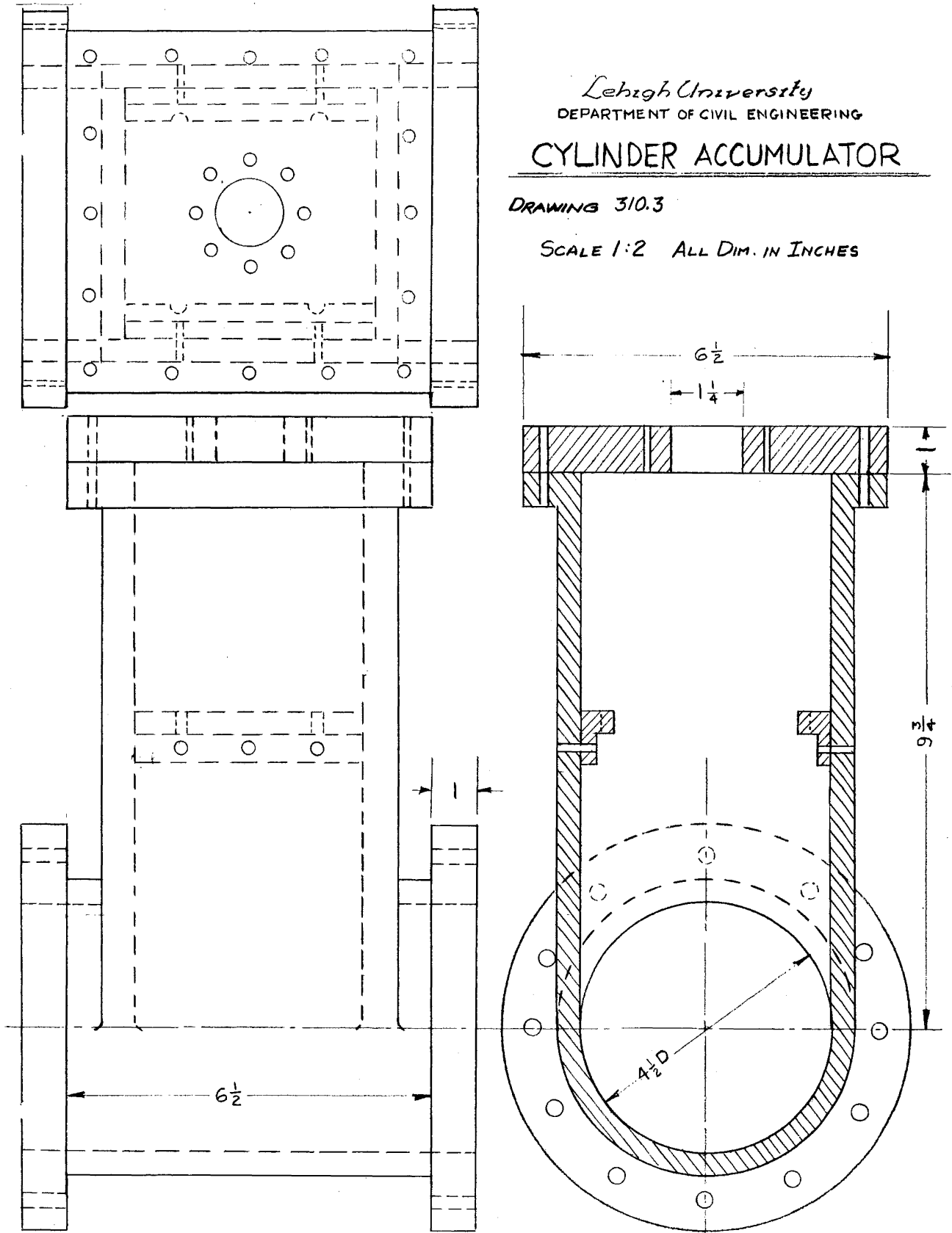

Figure 7

Cylinder Accumulator

## REFERENCES

- (1) John B. Herbich  
GAS REMOVAL SYSTEMS ASSOCIATED WITH DREDGE PUMPS  
Lehigh University, Fritz Engineering Laboratory Report No. 310.1,  
February 1964
- (2) P. A. Vesilind and J. B. Herbich  
GAS REMOVAL SYSTEMS ASSOCIATED WITH DREDGE PUMPS  
Lehigh University, Fritz Engineering Laboratory Report No. 310.2,  
April 1964
- (3) John B. Herbich  
GAS REMOVAL SYSTEMS ASSOCIATED WITH DREDGE PUMPS: PHASE B  
Lehigh University, Fritz Engineering Laboratory Report No. 310.4,  
October 1964
- (4) John B. Herbich and W. P. Isaacs  
GAS REMOVAL SYSTEMS PART I: LITERATURE SURVEY AND FORMULATION OF  
TEST PROGRAM  
Lehigh University, Fritz Engineering Laboratory Report No. 310.3,  
June 1964
- (5) A. Shindala, J. B. Herbich, A. Amatangelo, and G. Bagge  
GAS REMOVAL SYSTEMS PHASE B: PART 1 FORMULATION OF TEST PROGRAM  
DEVELOPMENT OF FACILITY LAYOUT  
Lehigh University, Fritz Engineering Laboratory Report No. 310.5,  
December 1964