

1966

Elastic-plastic load-deflection curve considering second-order effects and instability, October 1966, CE 406, M.S.

D. G. Follett Jr.

Follow this and additional works at: <http://preserve.lehigh.edu/engr-civil-environmental-fritz-lab-reports>

Recommended Citation

Follett, D. G. Jr., "Elastic-plastic load-deflection curve considering second-order effects and instability, October 1966, CE 406, M.S." (1966). *Fritz Laboratory Reports*. Paper 122.
<http://preserve.lehigh.edu/engr-civil-environmental-fritz-lab-reports/122>

This Technical Report is brought to you for free and open access by the Civil and Environmental Engineering at Lehigh Preserve. It has been accepted for inclusion in Fritz Laboratory Reports by an authorized administrator of Lehigh Preserve. For more information, please contact preserve@lehigh.edu.

ELASTIC-PLASTIC LOAD-DEFLECTION CURVE
CONSIDERING SECOND-ORDER EFFECTS AND INSTABILITY

Lehigh University
Department of Civil Engineering

(submitted to Dr. A. Ostapenko in fulfillment
of the requirements for SPECIAL PROBLEMS IN
CIVIL ENGINEERING - CE 406)

October 1966

D. Gordon Follett, Jr.

Fritz Engineering Laboratory Report

No. 273.57

TABLE OF CONTENTS

	<u>Page</u>
ABSTRACT	1
1. INTRODUCTION	2
2. BACKGROUND DISCUSSION	4
2.1 Assumptions	4
2.2 First Order Elastic-Plastic Analysis	5
2.3 Secondary Effects	8
2.4 Instability of Equilibrium	9
2.5 Second Order Elastic-Plastic Analysis	10
3. ITERATIVE PROCESS	14
3.1 General Discussion	14
3.2 Stable Range Iteration	16
3.3 Varification of Results and Discussion of Accuracy	19
3.4 Unstable Range Iteration	22
3.5 Influence of Axial Force on the Plastic Moment	26
4. SUMMARY AND CONCLUSIONS	28
5. APPENDIX	29
5.1 Nomenclature	29
5.2 Sample Problem	31
6. REFERENCES	62

ABSTRACT

A method is here presented for a simplified approach to the problem of determining the second order elastic-plastic load-deflection curve, considering instability, for an unbraced, unsymmetrical multi-story plane building frame subject to relatively large column loads.

No account is taken of the reduction in the plastic moment capacity of the members which results from the presence of axial force. A brief discussion is presented at the end describing how this effect might be considered.

Much background material is included in an effort to give an understanding of how this method was evolved.

The actual method is really two processes. The first covers the solution of the problem when the frame is in the stable state. The second process treats the frame after it becomes unstable, but only to the extent that the point is located on the load-deflection curve where the final hinge of the failure mechanism forms.

Finally, a sample problem using a simple portal frame is included to show the reader an example of the application of the method. The results of this problem show that for column loads equal to twenty (20) times the beam load, the ultimate load capacity is equal to 64% of the simple plastic mechanism capacity.

1. INTRODUCTION

This paper starts with the premise that the reader desires to have before him the elastic-plastic load-deflection curve for an unbraced, unsymmetrically loaded plane frame and that he desires to consider second-order effects and instability. Such a frame could be subject to relatively large column loads as might be found in the lower stories of a multi-story building.

Conventional simple plastic theory formulates equilibrium on the undeformed structure. This procedure is neither safe nor reasonable where heavy vertical column loads exist such as in the lower stories of a multi-story building frame. Simply stated, the additional moment generated because of the relative displacement of the column ends times the vertical column loads--known as the "P- Δ " effect--becomes too large to be ignored.

As with all problems, there are many approaches to the solution of this problem. The methods described in Ref. (3) and (6) are examples of how the problem may be attacked. The procedure described in this report is an example of another approach. It is based on the assumptions that the relationship between moment and curvature is elastic-perfectly plastic and that residual stresses, strain reversal and the effect on the plastic moment of the axial and shear forces can all be neglected (see Section 2.1 for full list of assumptions). The method presented is really two methods, one deals with the structure in the stable range, the other deals with the unstable range.

In the appendix an example problem using a fixed-ended portal frame subject to vertical, horizontal and heavy vertical column loads is used to illustrate the procedure and point out the importance of considering the P- Δ effects.

2. BACKGROUND DISCUSSION

2.1 ASSUMPTIONS

Certain basic assumptions are necessary before any further discussion can begin. The introduction touched on some of these in describing what this report covered.

The following is the list of assumptions:

1. Material elastic-perfectly plastic.

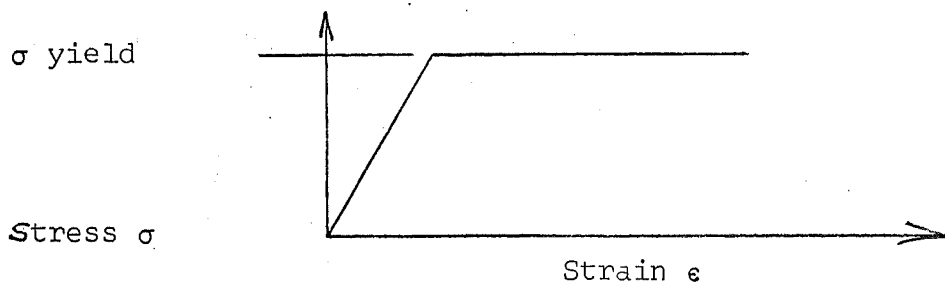

(Fig. 1)

- (a) Strain hardening neglected.

2. The relationship between moment and curvature elastic-perfectly plastic.

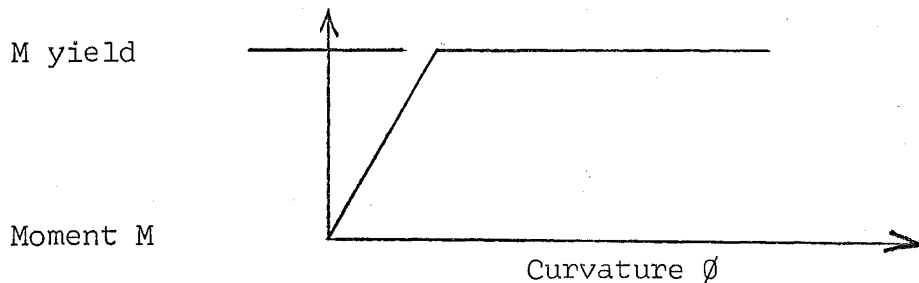

(Fig. 2)

- (a) Spread of plastification neglected.

3. Residual stresses neglected.

4. Strain reversal assumed not to take place.

5. Influence of shearing and axial forces on the plastic moment neglected.

6. First order-equilibrium formulated on the undeformed member.
7. Second order-equilibrium formulated on the deformed structure (P-Δ effect).
8. Instability included if it occurs prior to the formation of mechanism.
9. It is considered a failure when a mechanism forms in the structure.
10. Loading proportional.
11. Frame unbraced.
12. Either frame and/or loading unsymmetrical.
13. Loads act in a single plane and biaxial bending of columns not considered.
14. Lateral bracing with simple connections prevents out-of-plane deformation.
15. All joints rigid with sufficient strength to transmit the full plastic moment.

2.2 FIRST ORDER ELASTIC-PLASTIC ANALYSIS

Neglecting the secondary moment and stability problems caused by the P-Δ effect, i.e., the additional moment created when equilibrium is formulated on the deformed structure, the first order elastic-plastic load-deflection curve is constructed by means of a step-by-step procedure. The structure is assumed to have elastic regions which

control the deformations and localized plastic hinges. The load-deflection behavior is linear between the formation of successive plastic hinges. The load-deflection curve can be constructed by superimposing on the elastic load-deflection curve of the primary structure portions of the elastic load-deflection curves of auxiliary structures. The auxiliary structure is the resulting structure as each plastic hinge is formed. The analysis requires a separate elastic analysis after the formation of each consecutive plastic hinge. This leads to the generalized load-deflection curve shown below.

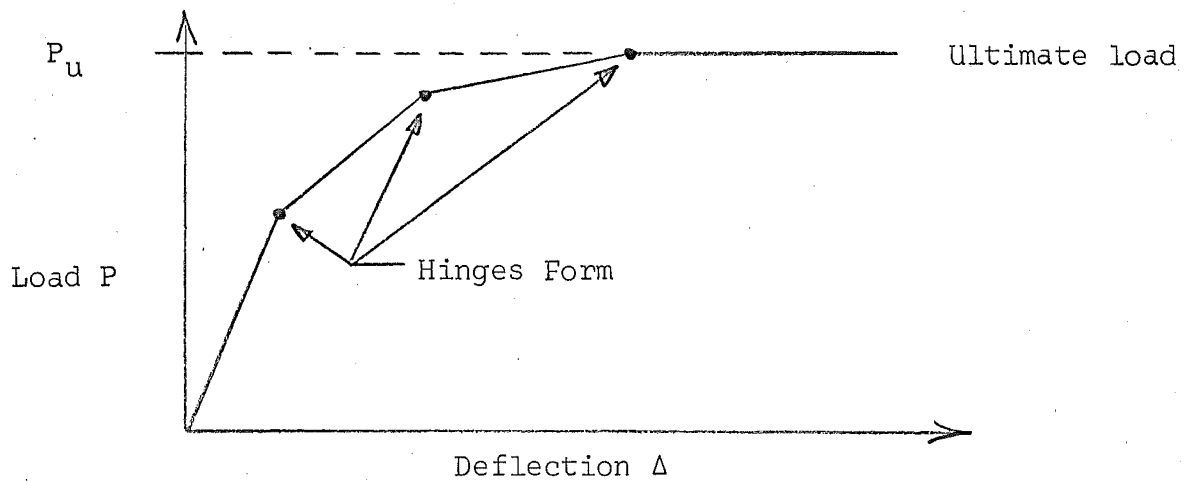

(Fig. 3)

The procedure for constructing the first order plastic load-deflection curve for a frame is as follows:

1. Analyze the structure elastically and draw the moment diagram in terms of an unknown force P_1 .
2. Let the maximum moment equal the plastic moment M_{p1} and solve for the value of P_1 .

3. With the load and the moments known, the deflection can be calculated and the point plotted on the load-deflection diagram.
4. Again analyze the frame elastically and plot the moment diagram in terms of a new unknown force P_2 but with a real hinge inserted in the structure at the location of the plastic moment, M_{p1} .
5. To determine the location of the second plastic moment, M_{p2} and the corresponding load P_2 , add the moment diagrams from step (2) and (4), then solve for P_2 . The smallest value of P_2 gives the correct location of the second plastic moment, M_{p2} (note that this value of P is the load increment, or additional load, necessary to form the second plastic hinge).
6. Repeat steps (3), (4) and (5) until all of the plastic hinges have formed, that is, until a mechanism has formed.

It is important to remember when calculating a deflection corresponding to the load necessary for the formation of a plastic hinge on the load-deflection curve at some point (A), that full continuity still exists in the structure at this hinge location. This means that in the deflection calculations a real hinge can not be inserted in the structure at point (A) until the next cycle.

2.3 SECONDARY EFFECTS

Structures which are subject to relatively high axial loads, such as the lower stories a multi-story building frame, cannot always be analyzed correctly without considering equilibrium of the deformed structure.

The various theorems and methods for the analysis of indeterminate structures which are dependent for their validity upon the applicability of the principle of superposition constitute what is known as the elastic theory. The principle of superposition requires two conditions before it can be applied to a structure:

1. A linear relationship must exist between stresses and strains, that is, the material must follow Hooke's law.
2. The change in shape of the structure as loads are applied may be neglected.

Violation of the first condition calls for a load-history analysis such as "Plastic Theory". Violation of the second condition requires the use of "Large Deflection Theory", or, it may be referred to as considering the "secondary effects" caused by the change in shape of the loaded structure. It must be noted here that both the elastic theory and the deflection theory consider the structure to be elastic but the latter condition requires that moments and forces be computed for the final deflected position.

There are several degrees of "exactness" when formulating equilibrium on the deformed structure. First, the least exact method, the method used in this paper, is to consider the deformed structure. In a

multi-story frame building the secondary moment, or the "additional" moment which would be calculated in the columns would come from considering the relative displacement of the column ends times the vertical component of the total axial load in the columns. This is known as the P- Δ effect.

Secondly, it would be necessary to consider equilibrium as formulated on the deformed member as well as the structure. The third and most exact method would be to add in the effect of axial shortening of the members.

2.4 INSTABILITY OF EQUILIBRIUM

An unbraced unsymmetrical frame with relatively high vertical loads on the columns, such as the lower stories of a multi-story building, may be subject to instability before a failure mechanism is formed. Under these conditions the second-order elastic-plastic load-deflection curve will actually reach the maximum load point, (zero slope), before the last plastic hinge forming the mechanism is developed. Any increase in deflection beyond this point must require a reduction in the load in order to maintain equilibrium.

This phenomenon of instability can be explained by using the following definition (Ref. 7, p. 407):

A system is said to be in a state of unstable equilibrium if, for any possible small displacement from the equilibrium configuration, upsetting forces will arise which tend to accelerate the system to depart even further from the equilibrium configuration.

The "upsetting forces" referred to in the above definition are the "secondary effects", specifically the P- Δ effect, described in Section 2.3 of this paper.

If one draws a generalized picture of the load-deflection curve as would result from applying the iterative method described in this report to a frame structure we get the following showing the stable and unstable range of behavior:

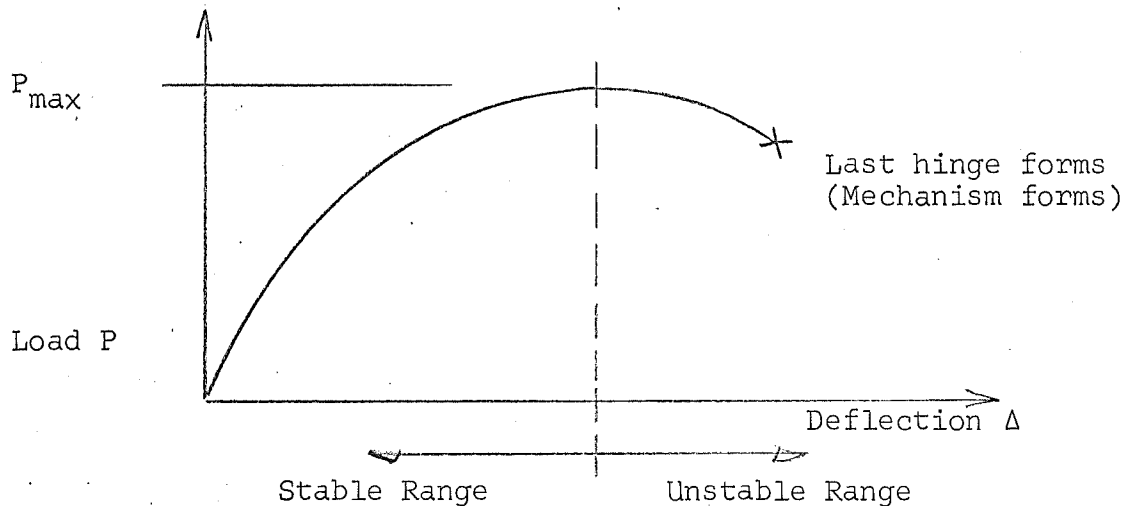

(Fig. 4)

At this point it might be well to note that the value of the maximum load is dependent on the loading sequence, however, if the structure is not subject to strain reversal in the plastified zones, the value of the load at the formation of the failure mechanism is unique and independent of the path of loading (Ref. 3, p. 13.10).

2.5 SECOND-ORDER ELASTIC-PLASTIC ANALYSIS

The second-order elastic-plastic load-deflection curve is constructed by means of a step-by-step procedure similar to the first-order curve discussed earlier. Again the load-deflection behavior is considered as linear between the formation of successive plastic hinges. The slope-deflection equation is used for solving the frame elastically. The secondary, or $P-\Delta$ moment, is introduced into the solution with a

condition equation by summing moments, including the P- Δ moment, about the base of one of the columns and then, by substitution, writing an expression in terms of the lateral loads, the P- Δ moment and the column end moments. This is sometimes referred to as the "overturning moments" equation.

The procedure for constructing the second-order elastic-plastic load-deflection curve using the slope-deflection method is as follows:

1. Analyze the structure elastically, including the P- Δ effect, using slope-deflection equation in terms of an unknown force P_1 .
2. Let each resulting moment, M , equal the plastic moment, M_{pl} , and solve the quadratic equations for P_1 . The root giving the smallest absolute value of P with a positive deflection gives the location of the first plastic hinge and the corresponding load P_1 .
3. Draw the moment diagram.
4. Determine the deflection at the desired location and plot the first point of the load-deflection curve.
5. With a real hinge inserted in the structure at the location of the plastic moment, the second point on the curve will be found.
6. To simplify the calculations, only the incremental change in moments and load are dealt with after the first hinge. The first auxiliary structure is now analyzed in a similar manner as step (2). Note that the condition equation, i.e., the sum of the moments about a column base, must deal only

with the moments caused by the additional deflection beyond that at the first hinge.

7. To determine the location of the second plastic hinge and the corresponding load P_2 , add the moment diagrams from step (3) and step (6), then solve as in step (2).
8. Repeat steps (5), (6) and (7) until all of the plastic hinges are developed, that is, until a mechanism has formed.

The solving of the simultaneous equations from the slope-deflection solution gives answers in the form of a quadratic. Here we see proof of the non-linear relationship between the elastic analysis and the secondary effects.

Of the two solutions obtained from the quadratic equations for the load P , the correct solution is the one which gives the smallest absolute value for P and also gives a positive value for the deflection.

A study was made of the second root but the exact physical meaning of the answer is not apparent. The following table gives the results of a problem, Fig. 5, solved by the slope-deflection method, that is used later to compare with the proposed iterative method:

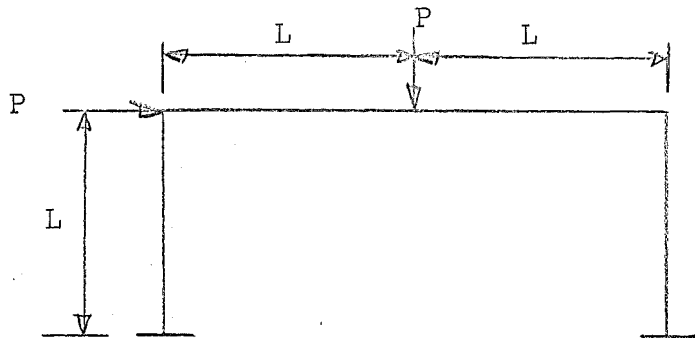

(Fig. 5)

	ROOT 1		ROOT 2	
	P	Δ	P	Δ
Hinge I	+0.14944	+	-10.19	-
	+0.05555	+	+ 4.57	+
	+0.03987*	+	+19.12	-
Hinge II	+0.01588	+	- 6.83	-
	+0.11166	+	- 2.95	-
	+0.01371	+	+ 2.34	-
	+0.00248*	+	+63.71	-
Hinge III	+0.00875	+	-15.82	-
	+0.05022	+	- 3.42	-
	+0.00588*	+	+ 3.67	-
Hinge IV	+0.00095*	+	- 4.15	-

* Correct Answer

3. ITERATIVE PROCESS

3.1 GENERAL DISCUSSION

Anyone using the slope-deflection procedure for constructing the second order elastic-plastic load-deflection curve described earlier will soon find it an extremely time consuming and arduous task even for the very simplest of frames. In an effort to simplify the procedure an approach is suggested based on assuming one or more of the unknowns and then iterating until an answer within a specified limit of accuracy is achieved.

A brief description of the stable range iteration process is as follows. This is the condition up to and including the point of maximum load.

1. Assume a load P .
2. Find the moment diagram without considering the second order effects.
3. Find the minimum load P required to produce the first hinge and find the moment diagram.
4. Compute the deflection.
5. Find the moment diagram for only the $P-\Delta$ effect.
6. Add the moment diagrams from parts (3) and (5).
7. Repeat starting with step (3) until convergence.

Two additional points should be mentioned. First, by separating the first order and second order moment determination, the non-linear part of the calculations is bypassed. The second point is to consider the general behavior of the iterative process. After adding the first and second order moment diagrams together, a linear relationship is assumed between the load and the moment. This tends to over compensate for any error in the previous value of the load. The values of the load will bounce back and forth, sometimes greater, sometimes less than the actual value sought, but eventually converging to the correct value.

The iteration process for the unstable range is not nearly so straight forward as in the stable case. As shown later, the approach used for the stable case will not work for the unstable case. The method adopted is a simplified version of that described in Ref. (4). This method gives the values of the deflection and load at the formation of the last hinge only, i.e., the formation of a mechanism. The points on the load-deflection curve at the formation of hinges other than the last one cannot be determined by this method. A brief description of the method is as follows:

1. Assume a failure mechanism and last hinge location.
2. Determine P_u , the ultimate load, by first-order rigid-plastic theory.
3. Compute the deflection.
4. Determine P_u by virtual work on the deformed structure.
5. Determine the deflection.
6. Repeat starting with step (4) until P_u converges.

7. Checks:

(a) Plasticity condition ($M \leq M_p$)

(b) Location of the last hinge.

If checks not satisfied, repeat computations for a new mechanism and/or last hinge location.

3.2 STABLE RANGE ITERATION

As previously discussed, the stable range iteration is used to determine the points on the load-deflection curve up to and including the point of maximum load. If a failure mechanism develops at this point, the curve is complete. If the failure mechanism has not developed, the unstable range iteration that is described later must be used.

The steps of the solution can very neatly be set up in table form to minimize the work as is shown in the sample problem. It has been found convenient to treat the P- Δ effect as a horizontal force equal to $\frac{P-\Delta}{H}$ where H is the column height associated with the relative horizontal displacement of the column ends, Δ , and P is the vertical column load.

The preliminary step required before beginning the iteration for each hinge is to determine the moment diagram of the structure for unit loads and unit $\frac{P-\Delta}{H}$. The rest of the procedure is as follows:

First hinge:

1. Using the unit moments from the preliminary step, find the first order load by proportion and resulting moment diagram.

necessary to develop the first plastic hinge. The location of the first hinge will be at the point of maximum moment for the unit load moment diagram. The load will also be the minimum load necessary to develop the plastic moment.

2. Determine the horizontal deflection of the column ends, Δ .
3. Determine the factor χ , that is, $\frac{P-\Delta}{H}$.
4. Using the moments from the preliminary step, find the resulting moment diagram for χ by proportion.
5. Add the moment diagrams from step (1) and (4).
6. Find the new load for cycle two by proportion between the load from step (1), the maximum moment from step (5) and the plastic moment, $\frac{P_2}{P_1} = \frac{M_p}{M_{\max 1}}$
7. Repeat steps (2) thru (6) until the change in the value of the load between cycles is within the desired accuracy.

Second hinge:

1. Insert a real hinge at the point of the plastic moment as determined for the first hinge and proceed with the preliminary step for the resulting auxiliary structure.
2. Using the final moment diagram for the first hinge, determine the amount of additional moment, $M_p - M_i$ at each critical location, i , that is, where a plastic hinge might form, required to form the plastic moment on the new structure.

3. Find the minimum incremental load necessary to form the next hinge and draw the moment diagram similar to step (1) for the first hinge.
4. Determine the incremental horizontal deflection of the column ends, Δ .
5. Determine λ , $\frac{P-\Delta}{H}$, for the second hinge. Since we are working with incremental moments, loads, and deflections, we must include the additional P- Δ moment produced by the load necessary to form the first hinge being displaced the additional incremental amount necessary to form the second hinge.
6. Proceed as in step (4) of the first hinge determination and find the moment diagram for λ by proportion from the preliminary step.
7. Add the moment diagrams from steps (3) and (6).
8. Proceed as in step (6) of the first hinge determination but with the proportion based on step (2) of the second hinge determination. This must be done at each critical location i . The critical location giving smallest value of the incremental load change, P , is the correct location of the next plastic hinge.
9. Repeat steps (4) thru (8) as required for accuracy.

Additional hinges:

Proceed as in the second hinge determination but using the results obtained from the previous hinge.

3.3 VERIFICATION OF RESULTS AND DISCUSSION OF ACCURACY

In order to assure that this iterative method does indeed give a correct elastic-plastic load-deflection diagram and to help establish accuracy guide lines a test problem was solved by the slope-deflection method. (See section on "Second-Order Elastic-Plastic Load-Deflection Curve", Fig. 5 for sketch).

The following diagrams showing the moments with the mechanism formed give a comparison of the results:

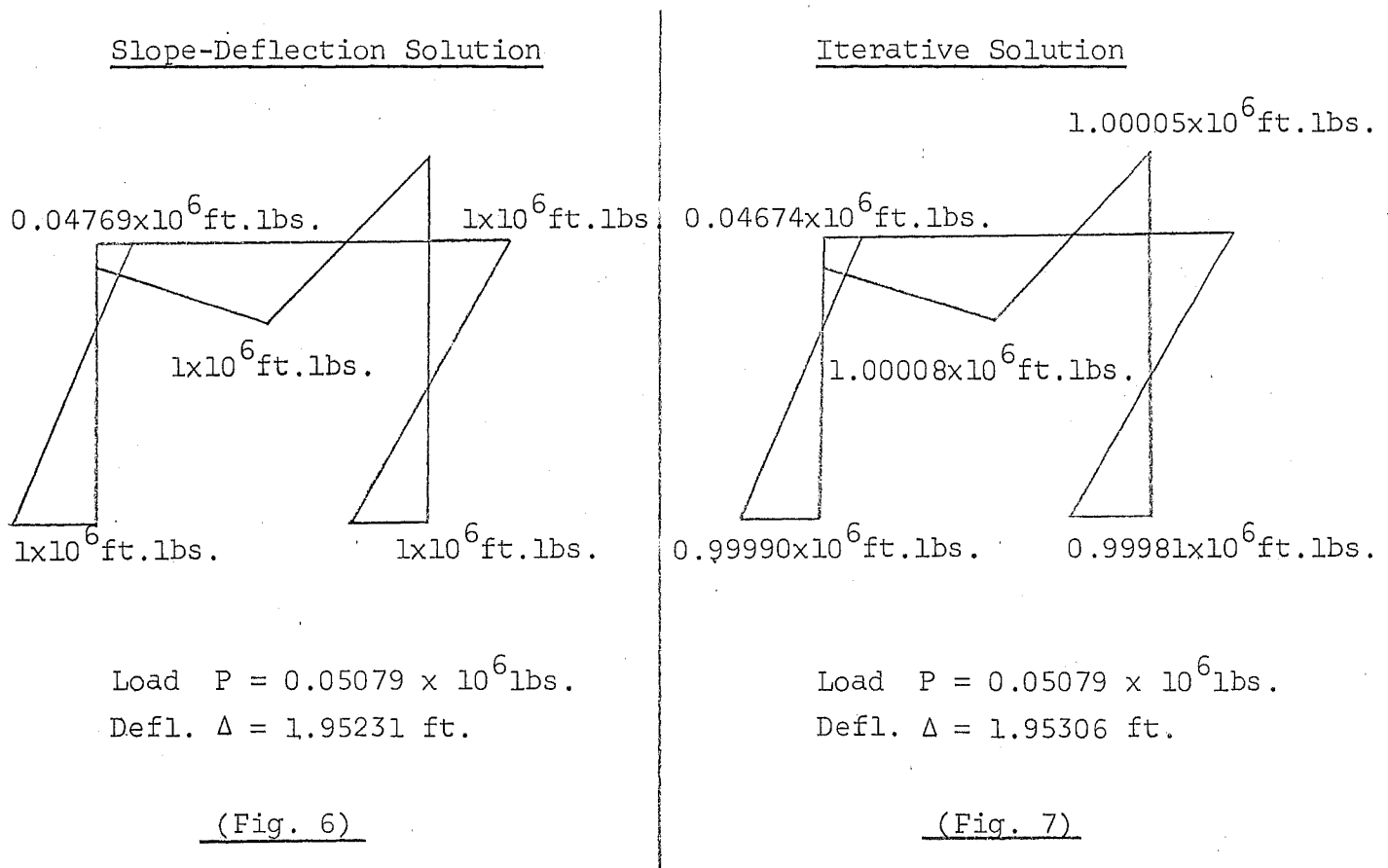

The results shown in the iterative solution were produced by continuing the iteration until there was no change between cycles in the last decimal place. The same problem was solved by limiting the iteration to one cycle and the results were quite accurate ($P = 0.05073 \times 10^6$ lbs., $\Delta = 1.95382$ ft.).

The next step was to increase the loading on the column ends so as to cause the frame to reach a condition of instability before the formation of the failure mechanism. The treatment of this condition will be covered in the next section in some detail but it is necessary to mention it in connection with the discussion of the accuracy rules.

In the description of the stable iteration process it was assumed that the additional deflection produced by the P- Δ effect was so small that it could be neglected. This is not necessarily correct. In fact, there may not be any way of telling from the iteration process that a structure has reached the unstable condition without including this additional displacement. This was born out in the test problems where the structure seemed to be stable until the P- Δ deflection was included in the calculations.

A study was made of the two test problems described earlier and the following rules were developed to give an accuracy within approximately 1.0% for the value of the load P:

1. For the first two cycles use the standard iteration procedure as outlined in an earlier section.
2. Check the deflection at the end of cycle two using the final moment diagram, i.e, the sum of the first order and second order moments, and compare with Δ calculated from the first order moments alone.
3. If the difference in step (2) is greater than 10.0%, continue into cycle three using a modification of the standard procedure.

4. The modification is to base the deflection calculation on the final moment diagram of the previous cycle as in step (2) above rather than on the first order moments of the current cycle.
5. Continue cycling until the change in the Load P between cycles is less than 1.0%.
6. For all hinges after the first one these percentages can be based on the first hinge values since the largest proportion of the load and deflection will have taken place at the formation of the first hinge. For the first hinge calculations the percentages are based on the previous cycle values.

$$\text{percent change in } P = \frac{\text{change between cycles} \times 100}{\text{final value of } P \text{ at first hinge}}$$

$$\text{percent change in } \Delta = \frac{\text{change between cycles} \times 100}{\text{final value of } \Delta \text{ at first hinge}}$$

The modification described in step (4) simply incorporates the additional P- Δ displacement into the iteration. The obvious question is why not include the P- Δ deflection in step (4) from the beginning instead of bypassing it for the first two cycles. This was done in several test examples and it was found that the number cycles necessary for convergence increased two to three times with this additional complication.

The second cycle is used as the cut-off point in step (1) because the results of the first cycle give a very high value of P which is then corrected in the second cycle.

The 10.0% guide value in step (3) is highly empirical. The study of the test problems actually showed that errors up to 5.0% in the deflection still gave an accuracy well within the 1.0% limit for P. Thus the 10.0% value was chosen for convenience. Certainly this area could stand additional study and refinement.

3.4 UNSTABLE RANGE ITERATION

When using the stable range iteration, if the load P keeps getting smaller and smaller and seems to be heading for a limit of zero (0) and the deflection Δ is getting larger and larger, the process fails to converge. This means the structure has reached the unstable state. The iteration process used for the stable range will not work when the frame is in the unstable state and a different approach must be used.

Part of the difficulty is that now that the structure has reached unstable equilibrium, the only way that equilibrium can be maintained with increasing deflection is to decrease the load. If this was the only problem, a simple modification of the stable iteration process would be the solution. Unfortunately, if this approach is tried it will soon become evident that convergence still is not going to take place. The reason for this becomes clearer if one looks at a true plot of the load-deflection diagram rather than the idealized plot of assumed straight lines used for this discussion. Usually no hinge will form at the point of maximum load and the idealized load-

deflection diagram will be a straight line between the last hinge to form in the stable state and the first hinge to form in the unstable state. The true plot, however, will rise up to a peak value of P and then drop off again somewhere between these two hinges.

If one is to write an equation for the incremental moment change between the last hinge in the stable state and the first hinge in the unstable state, one would be faced with an interesting dilemma. Knowing the additional moment required to develop the next hinge, an equation can be written with P and Δ as the unknowns consisting of two parts, the P - Δ moment and the first order moment due to a change in P . If this equation is plotted for various values of P , one finds that at P equal to zero, the deflection has a value. This would show up as a straight line on the load-deflection plot and is inconsistent with the physical nature of the problem. The only explanation for this dilemma is that the equation of the load-deflection plot is different on the stable side of the maximum load point than it is on the unstable side. Since the iteration method used for the stable range makes use of this type of equation, in order to use this method the formation of the last hinge before the frame reaches the unstable state must be at the point of maximum load or the moment diagram must be known when P is a maximum. Therefore, this type of solution was abandoned in favor of an approach utilizing a second-order rigid plastic solution.

The rigid plastic iterative process, though, is one which restricts the user to finding the load P and the deflection Δ at the formation of the last hinge only. The basic procedure is a simplified

version of the method described in reference (4). This method includes the effect of axial force on the plastic moment and for this discussion, as stated earlier, this effect is being ignored. The procedure is as follows:

1. Assume a failure mechanism and last hinge location.
2. Determine P_u , the ultimate load, by first-order rigid-plastic theory. This is done by remembering the basic ideas of applying virtual work to the "mechanism method" of solving a structure using rigid-plastic theory:
 - a. If a virtual displacement is applied to a system which is in equilibrium, the total work done is equal to zero.
 - b. Virtual displacement is any that is convenient to use with the assumption that the line of action of the forces does not change.
 - c. Virtual distortions are usually assumed as the distortion of a linkage system the same as the failure mechanism with no deformation between points of rotation and with angular changes at the locations of possible plastic hinges.
3. Find the horizontal deflection of the column ends, Δ .
4. With the deflection in (3) determine the ultimate load, P_u , by virtual work on the deformed structure. The additional consideration when using virtual work on the deformed structure is that the virtual displacement is applied to the structure with the mechanism already formed rather than the undeformed structure used in step (2).

5. Steps (3) and (4) are then repeated and a new P_u and Δ are determined for each cycle until the change in P_u between cycles is less than 1.0%.
6. There are two checks which must be made to determine if;
 - (1) the correct mechanism has been assumed; and (2) if the correct location of the last hinge has been assumed:
 - a. The correct mechanism has been assumed if at no point in the structure is the moment greater than the plastic moment

$$M \leq M_p$$

- b. Once the failure mechanism is confirmed a check must be made on the correctness of the assumed last hinge.

The general procedure is as follows (Ref. 8):

1. For a structure with R redundents, write R simultaneous virtual work equations to determine the values of θ_i , the concentrated slope changes at the plastic hinges.

- (a) Introduce the unit moment into the equilibrium structure in such a way that there is no external work to contend with in the virtual work equations.

$$W_{\text{external}} = W_{\text{internal}}$$

$$0 = \sum m_i \theta_i + \sum \frac{1}{EI} \int M m dx$$

m_i = unit internal moment on the equilibrium structure.

θ_i = plastic hinge rotation on the actual structure.

M = moment on the actual structure.
 m = moment on the equilibrium
structure.

(b) The best way to eliminate the external work is to put a double unit moment, (one for each slope change), on the equilibrium structure at the point of one of the plastic hinges and think of it as an internal moment. Be sure that this unit moment has the same sign as the plastic moment.

2. Solve these equations $R + 1$ times, (equal to the number of hinges required for a mechanism). Set each θ_i in turn equal to zero, i.e., equal to the last hinge with no rotation.
3. Solution in which no θ_i is equal to a minus value gives the correct last hinge (see Appendix 4.2 for sign convention).

3.5 INFLUENCE OF AXIAL FORCE ON THE PLASTIC MOMENT

In addition to causing instability, the presence of axial force tends to reduce the magnitude of the plastic moment. The effect is small in the case of small axial loads, and therefore in ordinary portal frame columns any reduction is usually ignored. However, in the case of multi-story structures, the resisting moment of the columns can be reduced by axial load and the evaluation of the ultimate load could include such consideration for a more accurate result. This

reduced moment is known as M_{pc} and can be derived by standard procedures (see Ref. 2).

In the previous discussion and in the example which follows the reduction of M_p to M_{pc} has been neglected. A possible modification in the stable iteration process to include this reduction would be to change from M_p to M_{pc} at the end of the second cycle and repeat the first two cycles. The discussion of the unstable iteration method including M_{pc} is covered in reference (4).

4. SUMMARY AND CONCLUSIONS

In summary, a method has been presented which gives a simplified approach to the problem of determining the second-order elastic-plastic load-deflection curve including the problem of instability. The method is a two-part iterative procedure - one part for the stable range, the other for the unstable range.

The stable range iteration separates the first order and second order moment determination. Although mutually interdependent, the procedure is to determine the first order moment and resulting deflection and then add the additional second order, or $P-\Delta$ moment. This process is repeated until convergence within a specified limit of accuracy is achieved. By using this type of procedure the time consuming non-linear part of the calculations is by-passed.

In order to assure that the stable iterative procedure does indeed give a correct elastic-plastic load deflection diagram, a test problem was solved by the slope-deflection method and by the iterative procedure. A comparison of results shows the same ultimate load by either system and only very small differences in the final moment diagrams. Also, as the result of a study of these test problems, rough empirical rules of accuracy for the iteration were developed.

After exploring several other approaches, the unstable range iteration procedure is developed from a method by Vogel (see Ref. 4) and restricts the user to finding the values of the load and deflection at the last hinge only.

In conclusion, since it has been shown that conventional simple plastic theory, which formulates equilibrium on the undeformed structure, is neither safe nor reasonable where heavy vertical column loads exist and the results of the sample problem show that for column loads equal to only twenty (20) times the beam load, the ultimate load capacity is reduced to 64% of the simple plastic mechanism capacity, it is necessary to find some simplified method of including the second order, or P- Δ moment, when dealing with the plastic analysis of heavily loaded columns.

5. APPENDIX

5.1 Nomenclature

Text

E	Modulus of elasticity
H	Column height of a story in a multi-story frame
I	Moment of inertia
M	Moment
M_{max}	Maximum moment
M_p	Plastic moment
M_{pc}	Reduced plastic moment
M_{yield}	Moment at yield
P	Concentrated load, axial load
P_u	Ultimate load
R	Number of redundents
W	Work
X	$P \times \Delta/H$
Δ	Lateral deflection of a story in a multi-story frame
ϵ	Strain
θ	End slope, rotation
σ	Stress
σ_{yield}	Stress at yield
ϕ	Curvature

Sample Problem

E	Modulus of elasticity
I	Moment of inertia
(i)	Critical location i where a plastic hinge might form.
L	Length or height
M	Moment
$M_{ADD.}$	Additional moment required to form plastic hinge
$M_{F.O.}$	First order moment (neglecting second order effects)
$M_{max.}$	Maximum moment
M_p	Plastic moment
M_x	Moment due to X
P	Concentrated load, axial load
P_u	Ultimate load
R	Number of redundents
W	Work
X	$P \times \Delta/L$
Z	Plastic modulus
Δ	Horizontal deflection of frame top
δ	Deflection
θ	End slope, rotation
σ_y	Stress at yield

5.2 SAMPLE PROBLEM

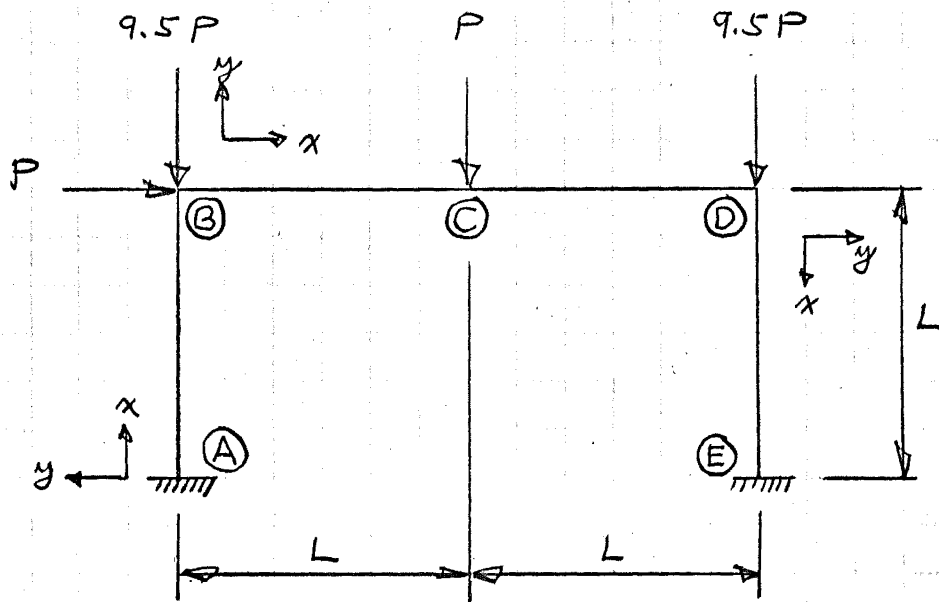

$I, z, E = \text{Constant for all members}$

Sign convention = (+) moment means tension on outside
 (+) slope means down to right along plus x axis

$$E = 30 \times 10^6 \text{ psi}$$

$$I = 2880 \text{ in.}^4$$

$$z = 333 \text{ in.}^4$$

$$L = 60 \text{ ft.}$$

$$\sigma_y = 36000 \text{ psi}$$

$$EI = 600 \times 10^6 \text{ lb.ft.}^2$$

$$M_p = z \sigma_y = 1 \times 10^6 \text{ lb.ft.}$$

Deflections are in feet
 Forces are in pounds
 Moments are in ft. lbs.

HINGE NO. 1

Preliminary steps

Moment diagram for unit loads:

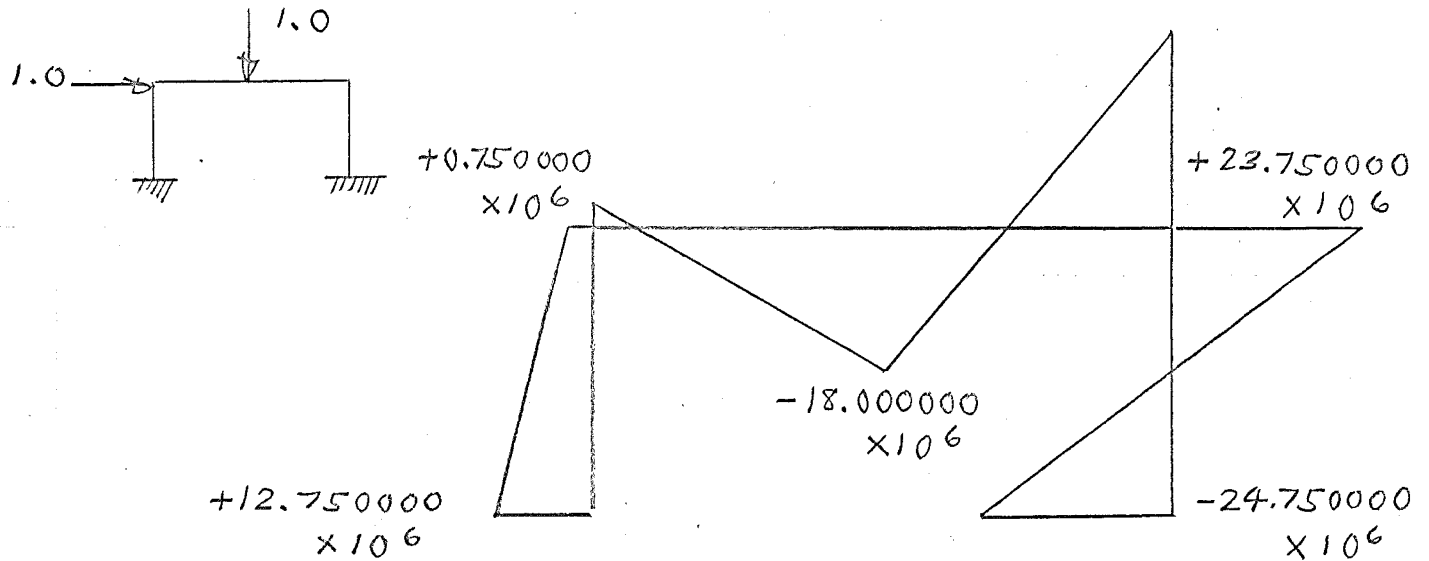

Moment diagram for unit $\frac{P \times \Delta}{H}$:

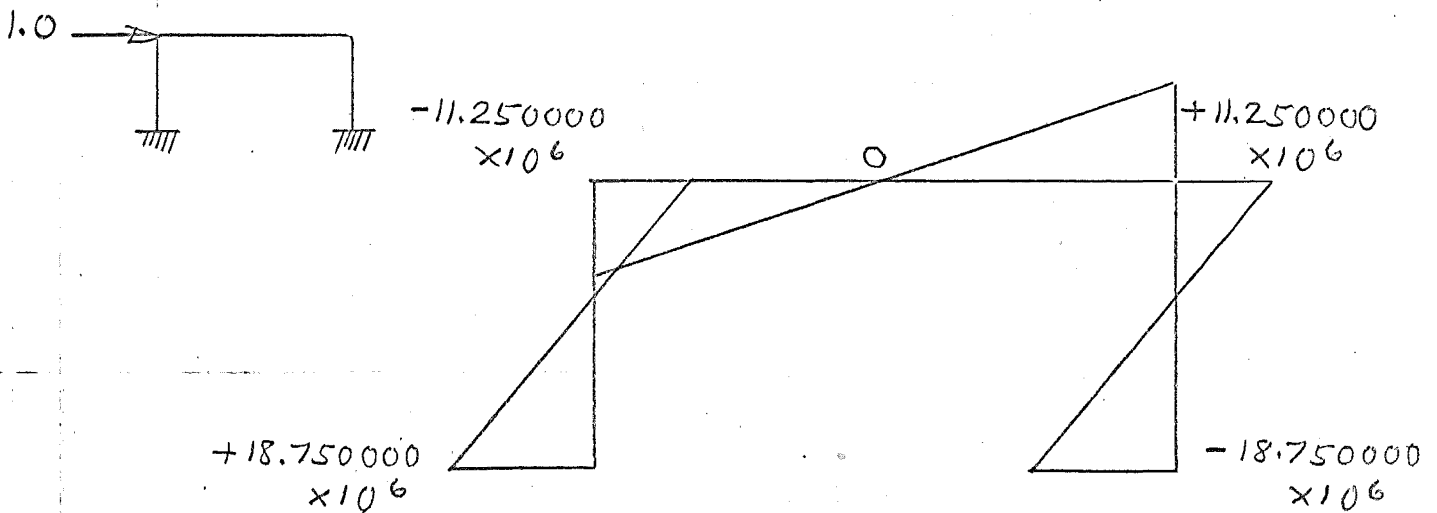

Cycle 1

step 1. First order load and resulting moment diagram

$$P_{11} = \frac{(M_{F0.11})(P_{10})}{M_{10 \text{ max.}}} = \frac{(M_{F0.11})(P_{10})}{M_{10} (\ominus)} = \frac{(-1.0 \times 10^6)(1.0)}{(-24.750 \times 10^6)}$$

$$P_{11} = 0.040404 \times 10^6$$

$$M_{F0.11} (\oplus) = \frac{(P_{11})(M_{10} (\ominus))}{P_{10}} = \frac{(0.040404 \times 10^6)(M_{10} (\ominus))}{1.0}$$

step 2. Horizontal deflection of column ends.

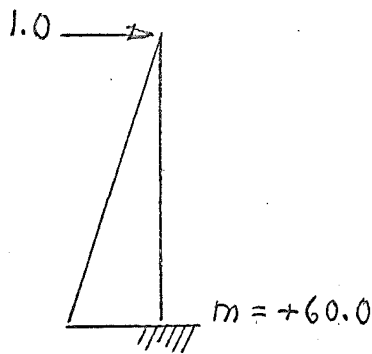

Equ. Stru.

$$\frac{EI \Delta_{11}}{10^6} = \int M m dx$$

$$\frac{EI \Delta_{11}}{10^6} = \left[0.515151 \begin{array}{c} \text{+} \\ \text{60.0} \end{array} \quad \begin{array}{c} \text{+} \\ \text{60.0} \end{array} \quad 0.030303 \right]$$

$$\frac{EI \Delta_{11}}{10^6} = \left(\frac{1}{6} \right) 60.0 \left[(2)(0.515151) + (0.030303) \right] (60)$$

$$EI \Delta_{11} = 1.060605 \times 600 \times 10^6$$

$$\Delta_{11} = 1.060605$$

step 3. Determine X

$$X_{11} = \frac{20(P_{11})(\Delta_{11})}{H} = \frac{(20)(0.040404 \times 10^6)(1.060605)}{60.0}$$

$$X_{11} = 0.014284 \times 10^6$$

Step 4. Moment diagram for X

$$M_{X_{11}} \textcircled{i} = \frac{(X_{11})(M_{X_{10}} \textcircled{i})}{X_{10}} = \frac{(0.014284 \times 10^6)(M_{X_{10}} \textcircled{i})}{1.0}$$

Step 5. Final moment diagram cycle 1

$$M_{11} \textcircled{i} = M_{F.O. 11} \textcircled{i} + M_{X_{11}} \textcircled{i}$$

Step 6. New load for cycle 2

$$P_{12} = \frac{(M_p)(P_{11})}{M_{11} \textcircled{i} \text{ MAX.}} = \frac{(1.0 \times 10^6)(0.040404 \times 10^6)}{M_{11} \textcircled{i}}$$

$$P_{12} = 0.031868 \times 10^6$$

Cycle 2

Step 7. Repeat steps (2) thru (6) until the change in the value of the load between cycles is within the desired accuracy

$$\Delta_{12} = [(2)(0.406317) + (0.023901)] = 0.836535$$

$$\frac{X_{12}}{10^6} = \frac{(20)(0.031868)(0.836535)}{60} = 0.008886$$

Check the deflection at the end of cycle two using the final moment diagram, i.e., the sum of the first order and second order moments, and compare with Δ calculated from the first order moments alone.

$$\Delta_1 = (2)(0.572930) - (0.076067) = 1.069793$$

$$\% \text{ change in } \Delta = \frac{(\Delta_1 - \Delta_{12})(100)}{\Delta_1} = \frac{(1.069793 - 0.836535)(100)}{1.069793} = 21.8\%$$

21.8% is greater than 10.0% allowed,
use the modification (see p.20-21)

Cycle 3

$$\Delta_{13} = 1.069793$$

$$\frac{X_{13}}{10^6} = \frac{(20)(0.033368)(1.069793)}{60} = 0.011898$$

Check the change in the load P

$$\% \text{ change in } P = \frac{(P_3 - P_4)(100)}{P_4}$$

$$\% \text{ change in } P = \frac{(0.033368 - 0.031810)(100)}{0.031810} = 4.9\%$$

4.9% is greater than 1.0% allowed,
go on to next cycle

Cycle 4

$$\Delta_{14} = 1.188233$$

$$\frac{X_{14}}{10^6} = 0.012599$$

$$\% \text{ change in } P = 2.4\% > 1.0\%$$

Cycle 5

$$\Delta_{15} = 1.165737$$

$$\frac{X_{15}}{10^6} = 0.012076$$

$$\% \text{ change in } P = 0.4\%$$

0.4% is less than 1.0%, therefore P_{ic}
is P_i

$$\Delta I = (2)(0.622670) - (0.112546) = 1.132794$$

HINGE NO. 1 - TABLE OF RESULTS

(all values $\times 10^6$)

	A	B	C	E	E
$P_{10} = 1.000000$	+ 12.750000	+ 0.750000	- 18.000000	+ 23.250000	- 24.750000
$P_{11} = 0.040404$	+ 0.515151	+ 0.030303	- 0.727272	+ 0.939393	- 1.000000
$X_{10} = 1.000000$	+ 18.750000	- 11.250000	0	+ 11.250000	- 18.750000
$X_{11} = 0.014284$	+ 0.267825	- 0.160695	0	+ 0.160695	- 0.267825
M_{11}	+ 0.782976	- 0.130392	- 0.727272	+ 1.100088	- 1.267825
$P_{12} = 0.031868$	+ 0.406317	+ 0.023901	- 0.573624	+ 0.740931	- 0.788414
$X_{12} = 0.008886$	+ 0.166613	- 0.099968	0	+ 0.099968	- 0.166613
M_{12}	+ 0.572930	- 0.076067	- 0.573624	+ 0.840899	- 0.955027
$P_{13} = 0.033368$	+ 0.425442	+ 0.025026	- 0.600624	+ 0.775806	- 0.825852
$X_{13} = 0.011898$	+ 0.223088	- 0.133853	0	+ 0.133853	- 0.223088
M_{13}	+ 0.648530	- 0.108827	- 0.600624	+ 0.909659	- 1.048946
$P_{14} = 0.031810$	+ 0.405578	+ 0.023858	- 0.572580	+ 0.739583	- 0.787298
$X_{14} = 0.012599$	+ 0.236231	- 0.141739	0	+ 0.141739	- 0.236231
M_{14}	+ 0.641809	- 0.117881	- 0.572580	+ 0.881322	- 1.023529
$P_{15} = 0.031078$	+ 0.396245	+ 0.023309	- 0.559401	+ 0.559404	- 0.769181
$X_{15} = 0.012076$	+ 0.226425	- 0.135855	0	+ 0.135855	- 0.226425
M_{15}	+ 0.622670	- 0.112546	- 0.559404	+ 0.858419	- 0.995606
$P_{16} = 0.031215$					

$$P_1 = 0.031215 \times 10^6$$

$$\Delta_1 = 1.132794$$

HINGE NO. 2

Step 1. Preliminary steps

Moment diagram for unit loads:

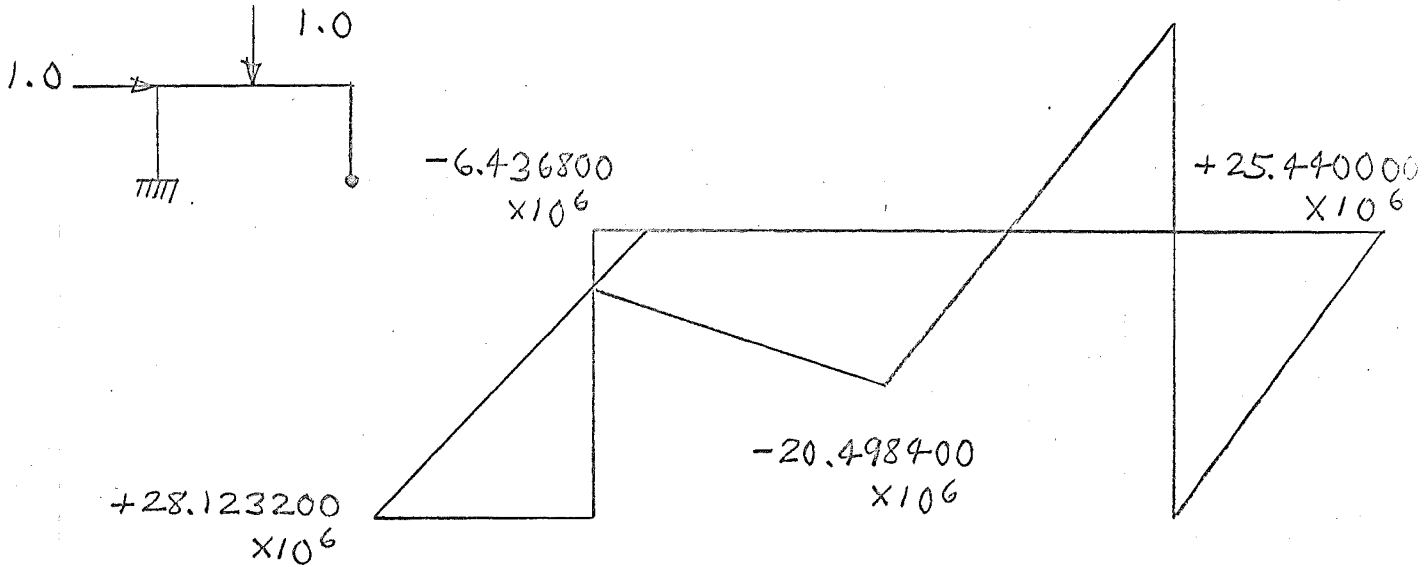

Moment diagram for unit $\frac{P \times \Delta}{H}$:

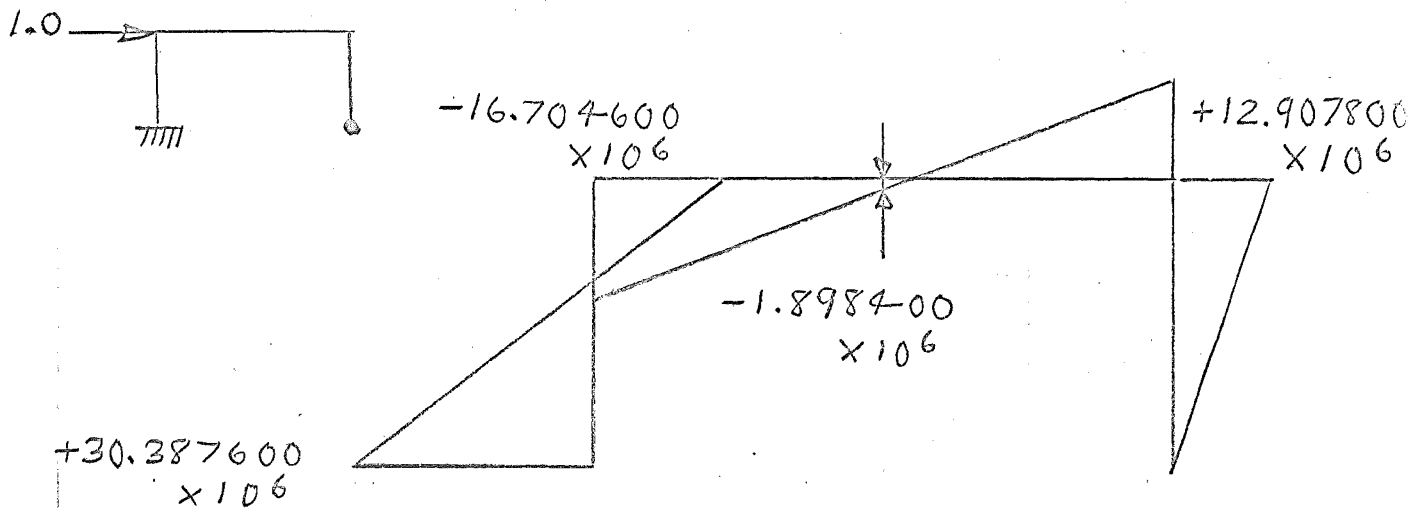

Step 8. New load for cycle 2

$$P_{22} = \frac{(M_{ADD, i})(P_{21})}{M_{21} \text{ (i)}}$$

Cycle 2

Step 9. Repeat steps (4) thru (8) until the change in the value of the load between cycles is within the desired accuracy.

$$\Delta_{22} = [(2)(0.121577) - (0.027826)] = 0.215328$$

$$\frac{X_{22}}{10^6} = \frac{(20)(0.031215)(0.215328) + (20)(0.004323)(1.348122)}{60}$$

$$\frac{X_{22}}{10^6} = 0.002166$$

Check the change in Δ

$$\Delta_2 = (2)(0.187397) - (0.064008) = 0.310786$$

$$\% \text{ change in } \Delta = \frac{(\Delta_2 - \Delta_{22})(100)}{\Delta_1} = \frac{(0.310786 - 0.215328)(100)}{0.132794}$$

$$\% \text{ change in } \Delta = 8.4\%$$

8.4% is less than 10.0% allowed, therefore no modification of the standard procedure is required

Check the change in P

$$\% \text{ change in } P = \frac{(P_{23} - P_{22})(100)}{P_1}$$

$$\% \text{ change in } P = \frac{(0.004437 - 0.004323)(100)}{0.031215} = 0.0027\%$$

0.0027% is less than 1.0%, therefore P_{23} is P_2

HINGE NO. 2 - TABLE OF RESULTS

(all values $\times 10^6$)

	A	B	C	D	E
$M_P - M_{15} \textcircled{2}$	+ 0.377330	- 0.887454	- 0.440596	+ 0.141581	0
$P_{20} = 1.000000$	+ 28.123200	- 6.436800	- 20.498400	+ 25.440000	0
P_{21}	0.013417	0.137871	0.021494	0.005565	0
$P_{21} = 0.005565$	+ 0.156506	- 0.035821	- 0.114074	+ 0.141574	0
$X_{20} = 1.000000$	+ 30.387600	- 16.704600	- 1.898400	+ 12.907800	0
$X_{21} = 0.003147$	+ 0.095691	- 0.052603	- 0.005978	+ 0.040647	0
M_{21}	+ 0.252197	- 0.088424	- 0.120052	+ 0.182221	0
P_{22}	0.008329	0.055852	0.020423	0.004323	0
$P_{22} = 0.004323$	+ 0.121577	- 0.027826	- 0.088615	+ 0.109977	0
$X_{22} = 0.002166$	+ 0.065820	- 0.036182	- 0.004112	+ 0.027958	0
M_{22}	+ 0.187397	- 0.064008	- 0.092727	+ 0.137935	0
P_{23}	0.008704	0.059937	0.020540	0.004437	0
$P_{23} = 0.004437$					

$$P_2 = 0.004437 \times 10^6$$

$$\Delta_2 = 0.310786$$

HINGE NO. 3

Preliminary steps

Moment diagram for unit loads:

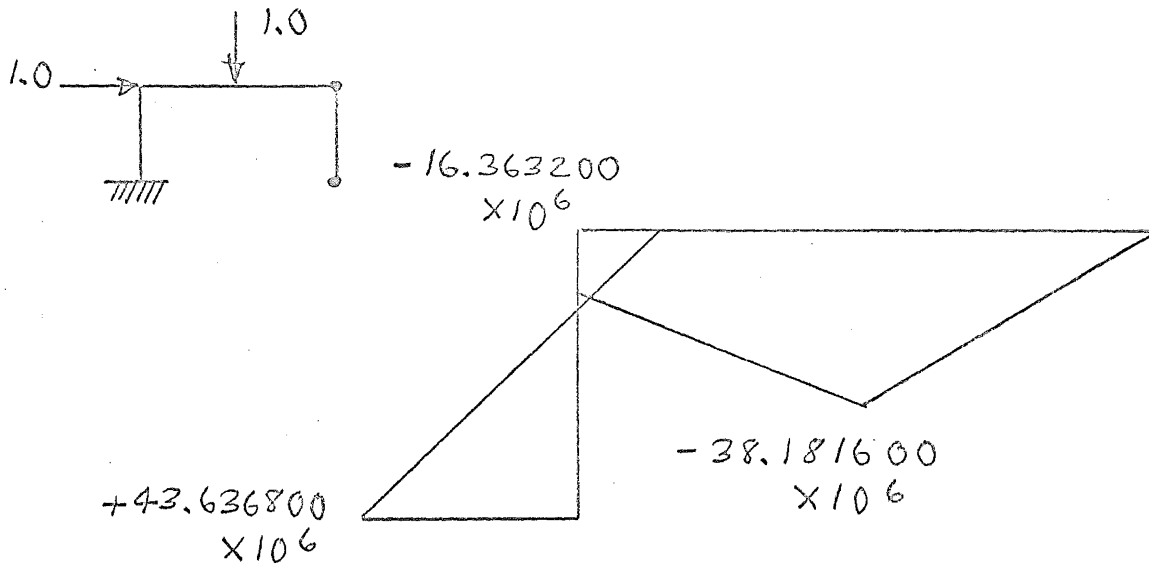

Moment diagram for unit $\frac{P \times \Delta}{H}$:

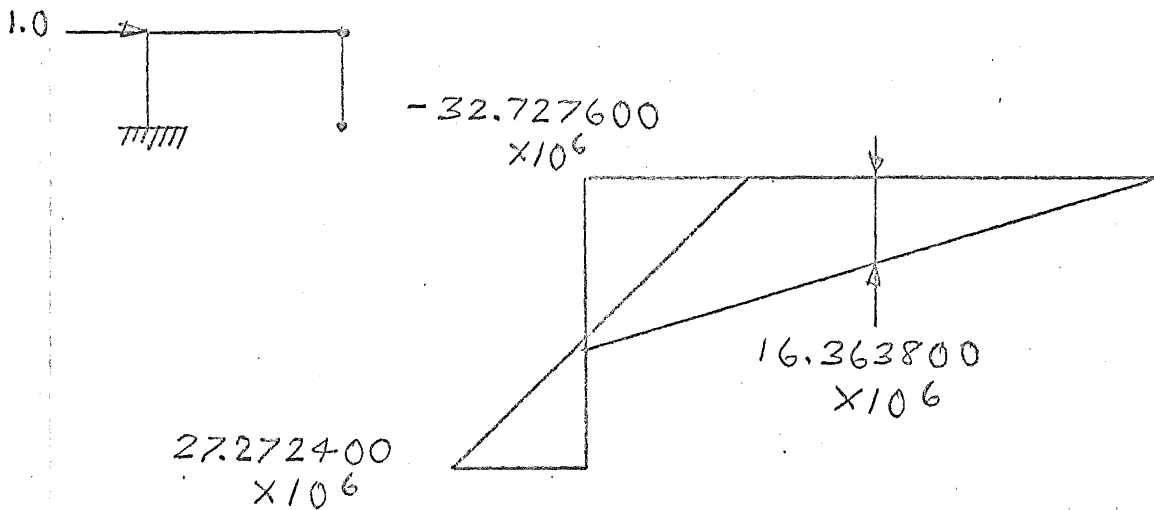

Cycle 1

$$\frac{EI \Delta_{31}}{10^6} = \left[\begin{array}{ccc} 0.189907 & \begin{array}{c} \nearrow \\ \searrow \end{array} & 0.071213 \\ & 60.0 & \end{array} \right]$$

$$\frac{EI \Delta_{31}}{10^6} = \left(\frac{1}{6}\right)(60) \left[(2)(0.189907) - (0.071213) \right] (60)$$

$$\Delta_{31} = 0.308601$$

$$X_{31} = \frac{(20)(P_{16} + P_{23})(\Delta_{31}) + (20)(P_{31})(\Delta_1 + \Delta_2 + \Delta_{31})}{H}$$

$$\frac{X_{31}}{10^6} = \frac{(20)(0.035688)(0.308601) + (20)(0.004352)(1.752181)}{60}$$

$$X_{31} = 0.006212 \times 10^6$$

Cycle 2

$$\Delta_{32} = (2)(0.100365) - (0.037635) = 0.163095$$

$$\frac{X_{32}}{10^6} = \frac{(20)(0.035688)(0.163095) + (20)(0.002300)(1.606675)}{60}$$

$$X_{32} = 0.003171 \times 10^6$$

Check the change in Δ

$$\Delta_3 = (2)(0.186845) - (0.141414) = 0.232276$$

$$\% \text{ change in } \Delta = \frac{(0.232276 - 0.163095)(100)}{1.132794} = 6.1\%$$

6.1% is less than 10.0% allowed, therefore no modification of the standard procedure is required

check the change in P

$$\% \text{ change in } P = \frac{(0.002338 - 0.002300)(100)}{0.031215} = 0.12\%$$

0.12% is less than 1.0%, therefore P₃₃
is P₃

HINGE NO. 3 - TABLE OF RESULTS

(all values $\times 10^6$)

	A	B	C	D	E
$M_p - (M_{15} + M_{22}) \textcircled{2}$	+ 0.18 99 33	- 0.82 34 46	- 0.34 78 69	0	0
$P_{30} = 1.00 00 00$	+ 43.63 68 00	- 16.36 32 00	- 38.18 16 00	0	0
P_{31}	0.00 43 52	0.05 03 23	0.00 91 10	0	0
$P_{31} = 0.00 43 52$	+ 0.18 99 07	- 0.07 12 13	- 0.16 61 66	0	0
$X_{30} = 1.00 00 00$	+ 27.27 24 00	- 22.72 76 00	- 16.36 38 00	0	0
$X_{31} = 0.00 62 12$	+ 0.16 94 16	- 0.20 23 04	- 0.10 16 52	0	0
M_{31}	+ 0.35 93 23	- 0.27 45 17	- 0.26 78 18	0	0
P_{32}	0.00 23 00	0.01 30 54	0.00 56 52	0	0
$P_{32} = 0.00 23 00$	+ 0.10 03 65	- 0.03 76 35	- 0.08 78 18	0	0
$X_{32} = 0.00 31 71$	+ 0.08 64 80	- 0.10 37 79	- 0.05 18 90	0	0
M_{32}	+ 0.18 68 45	- 0.14 14 14	- 0.13 97 08	0	0
P_{33}	0.00 23 38	0.01 33 92	0.00 57 26	0	0
$P_{33} = 0.00 23 38$					

$$P_3 = 0.002338 \times 10^6$$

$$\Delta_3 = 0.232276$$

HINGE NO. 4

Preliminary steps

Moment diagram for unit loads:

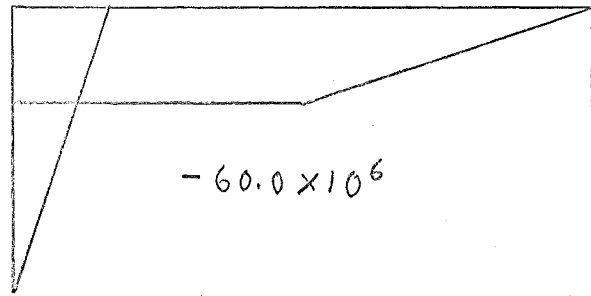
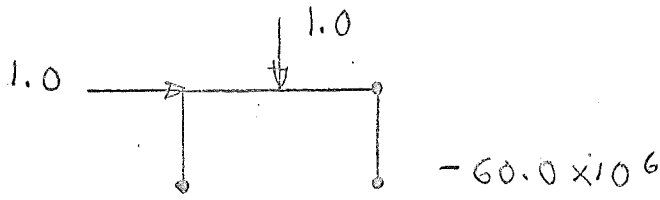

Moment diagram for unit $\frac{P \times \Delta}{H}$:

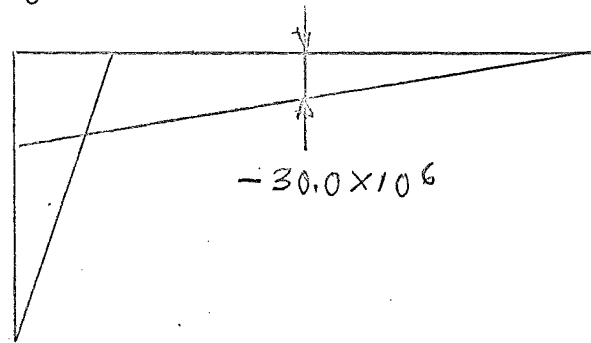

Cycle 1

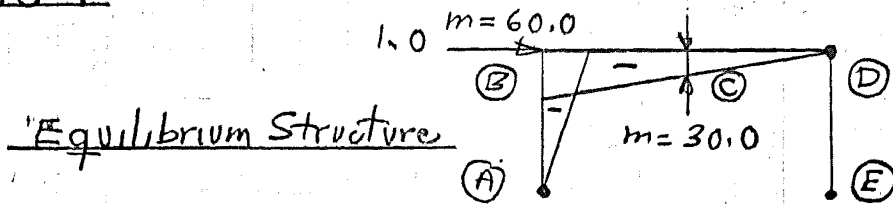

$$\frac{EI \Delta_{41}}{10^6} = \left[\begin{array}{c} \text{Triangular load } 0.208140 \\ \text{over } 60.0 \end{array} \right] + \left[\begin{array}{c} \text{Rectangular load } 0.208140 \\ \text{over } 60.0 \text{ and } 30.0 \end{array} \right] + \left[\begin{array}{c} \text{Triangular load } 0.208140 \\ \text{over } 30.0 \end{array} \right]$$

$$\frac{EI \Delta_{41}}{10^6} = \left(\frac{1}{3} \right) (0.208140) (60) (60) + \left(\frac{1}{2} \right) (0.208140) (60+30) (60) + \left(\frac{1}{3} \right) (0.208140) (30) (60)$$

$$\Delta_{41} = 1.561050$$

$$\frac{X_{41}}{10^6} = \frac{(20)(P_{16} + P_{23} + P_{33})(\Delta_{41}) + (20)(P_{41})(\Delta_1 + \Delta_2 + \Delta_3 + \Delta_{41})}{H}$$

$$\frac{X_{41}}{10^6} = \frac{(20)(0.038026)(1.561050) + (20)(0.003469)(3.236906)}{60}$$

$$X_{41} = 0.023529 \times 10^6$$

Cycle 2

$$\frac{EI \Delta_{42}}{10^6} = (1200)(0.047400) + (2700)(0.047400) + (600)(0.047400)$$

$$\Delta_{42} = 0.355500$$

$$\frac{X_{42}}{10^6} = \frac{(20)(0.038026)(0.355500) + (20)(0.000790)(2.031356)}{60}$$

$$X_{42} = 0.005033 \times 10^6$$

Check the change in Δ

$$\frac{EI \Delta_4}{10^6} = \left[\begin{array}{c} \triangleleft 0.349380 \\ \triangleleft 60.0 \\ \hline 60.0 \end{array} \right] + \left[\begin{array}{c} 0.349380 \triangleleft \\ 60.0 \triangleleft \\ \hline 60.0 \end{array} \right] + \left[\begin{array}{c} 0.198390 \triangleleft \\ 30.0 \triangleleft \\ \hline 60.0 \end{array} \right]$$

$$+ \left[\begin{array}{c} 0.198390 \triangleleft \\ 30.0 \triangleleft \\ \hline 60.0 \end{array} \right]$$

$$\frac{EI \Delta_4}{10^6} = \left(\frac{1}{3}\right)(0.349380)(60)(60) + \left(\frac{1}{6}\right) \left[(2)(0.349380 \times 60 + 0.198390 \times 30) + 0.198390 \times 60 + 0.349380 \times 30 \right] (60) + \left(\frac{1}{3}\right)(0.198390)(30)(60)$$

$$\Delta_4 = 2.169180$$

$$\% \text{ change in } \Delta = \frac{(2.169180 - 0.355500)(100)}{1.132794} = 160.1\%$$

160.1% is greater than 10.0% allowed, therefore use the modified standard procedure

Cycle 3

$$\Delta_{43} = 2.169180$$

$$\frac{X_{43}}{10^6} = \frac{(20)(0.038026)(2.169180) + (20)(0.000828)(3.845036)}{60}$$

$$X_{43} = 0.025986 \times 10^6$$

Check the change in P

$$\% \text{ change in } P = \frac{(0.00828 - 0.000207)(100)}{0.031215} = 1.9\%$$

1.9% is greater than 1.0% allowed

Cycle 4

$$\Delta_{44} = (2)(1.608840) + \left(\frac{1}{2}\right) \left[(2)(1.608840 \times 2 + 0.829260) \right. \\ \left. + (2)(0.829260) + 1.608840 \right] + 0.829260$$

$$\Delta_{44} = 9.727560$$

$$\frac{\Sigma_{44}}{10^6} = \frac{(20)(0.038026)(9.727560) + (20)(0.000207)(11.403416)}{60}$$

$$\Sigma_{44} = 0.113518 \times 10^6$$

HINGE NO. 3 - TABLE OF RESULTS

(all values $\times 10^6$)

	A	B	C	D	E
$M_p - (M_{15} + M_{22} + M_{32})$	0	- 0.682032	- 0.208161	0	0
$P_{40} = 1.000000$	0	- 60.000000	- 60.000000	0	0
P_{41}	0	0.011367	0.003469	0	0
$P_{41} = 0.003469$	0	- 0.208140	- 0.208140	0	0
$X_{40} = 1.000000$	0	- 60.000000	- 30.000000	0	0
$X_{41} = 0.023529$	0	- 1.411740	- 0.705870	0	0
M_{41}	0	- 1.619880	- 0.914010	0	0
P_{42}	0	0.001460	0.000790	0	0
$P_{42} = 0.000790$	0	- 0.047400	- 0.047400	0	0
$X_{42} = 0.005033$	0	- 0.301980	- 0.150990	0	0
M_{42}	0	- 0.349280	- 0.198390	0	0
P_{43}	0	0.001542	0.000828	0	0
$P_{43} = 0.000828$	0	- 0.049680	- 0.049680	0	0
$X_{43} = 0.025986$	0	- 1.559160	- 0.779580	0	0
M_{43}	0	- 1.608840	- 0.829260	0	0
P_{44}	0	0.000251	0.000207	0	0
$P_{44} = 0.000207$	0	- 0.012420	- 0.012420	0	0
$X_{44} = 0.113518$	0	- 6.811080	- 3.405540	0	0
M_{44}	0	- 6.823500	- 3.417960	0	0
P_{45}	0	0.000020	0.000012	0	0
$P_{45} = 0.000012$					

P_{45} is approximately 0, the structure has reached the unstable state - must use unstable range iteration

Unstable range iteration

Step 1. Assume a failure mechanism and last hinge location

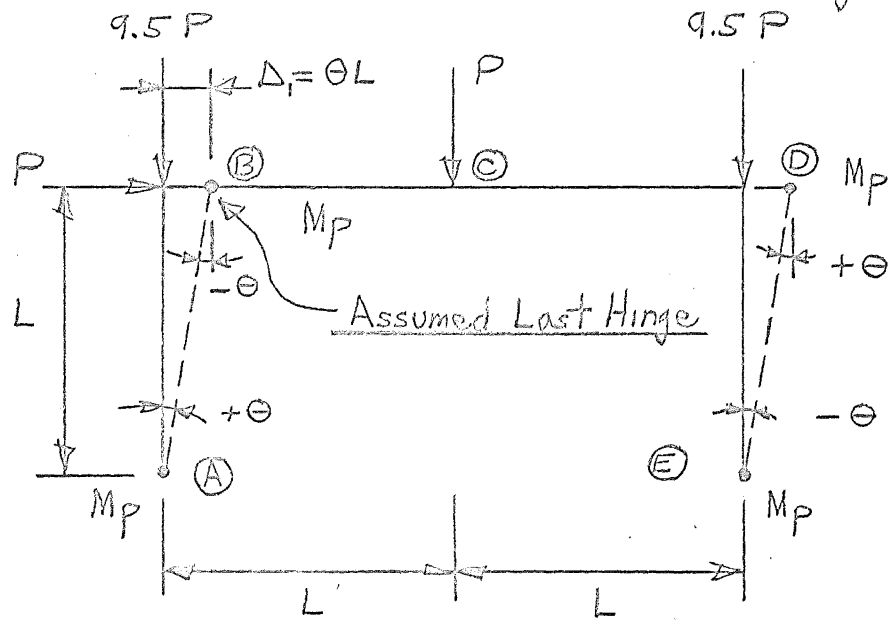

Step 2. Determine P_u

$$W_{ext.} = W_{int.}$$

$$(P_u)(\Delta_1) = (M_{P_A})(+\theta) + (-M_{P_B})(-\theta) + (M_{P_C})(+\theta) + (-M_{P_E})(-\theta)$$

$$P_u = \frac{1}{15} \times 10^6 = 0.066667 \times 10^6$$

Step 3. Horizontal deflection of column ends, Δ

(a) Determine complete moment diagram - use the method of an alternate mechanism

Wext. = Wint.
 $(P_{u1})(\delta) = M_{\theta}(+\theta) + M_{\theta}(-2\theta) + M_{\theta}(+\theta)$
 $(\frac{1}{15} \times 10^6)(60\theta) = (-M_p)(+\theta) + (M_p)(-2\theta) + (M_p)(+\theta)$
 $M_{\theta} = -2 \times 10^6$

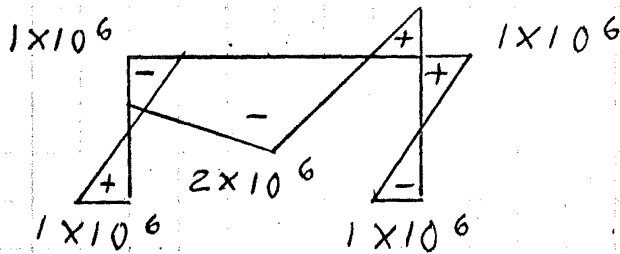
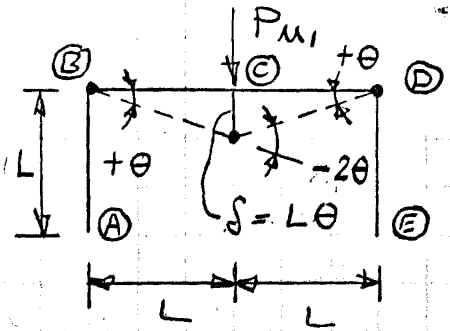

(b) Determine deflection

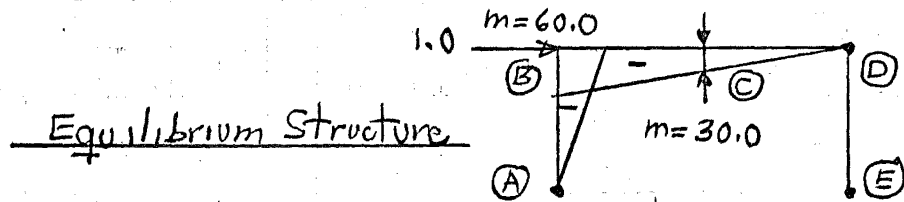

$$\frac{EI \Delta_1}{10^6} = \left[\begin{array}{c} 1.0 \text{ (triangle)} \\ \text{---} \\ 60.0 \end{array} \right] + \left[\begin{array}{c} 1.0 \text{ (trapezoid)} \\ \text{---} \\ 60.0 \end{array} \right] + \left[\begin{array}{c} 2.0 \text{ (triangle)} \\ \text{---} \\ 30.0 \end{array} \right]$$

$$\frac{EI \Delta_1}{10^6} = (\frac{1}{6})(60)(1.0)(60) + (\frac{1}{6})[(2)(2 \times 30 + 60) + (1)(2 \times 60 + 30)](60) + (\frac{1}{6})(30)(2 \times 2 - 1)(60)$$

$$\Delta_1 = 9.000000$$

Step 4. Determine P_{u2} on the deformed structure

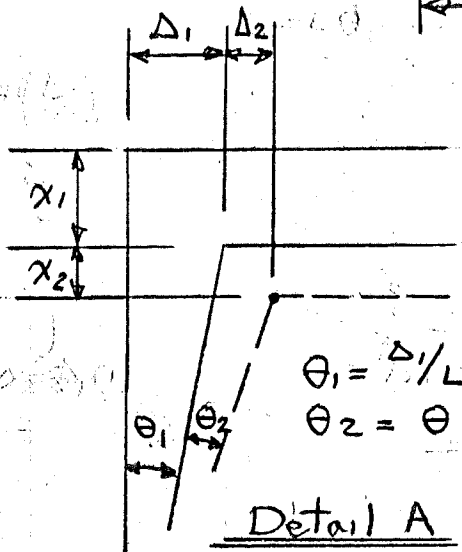
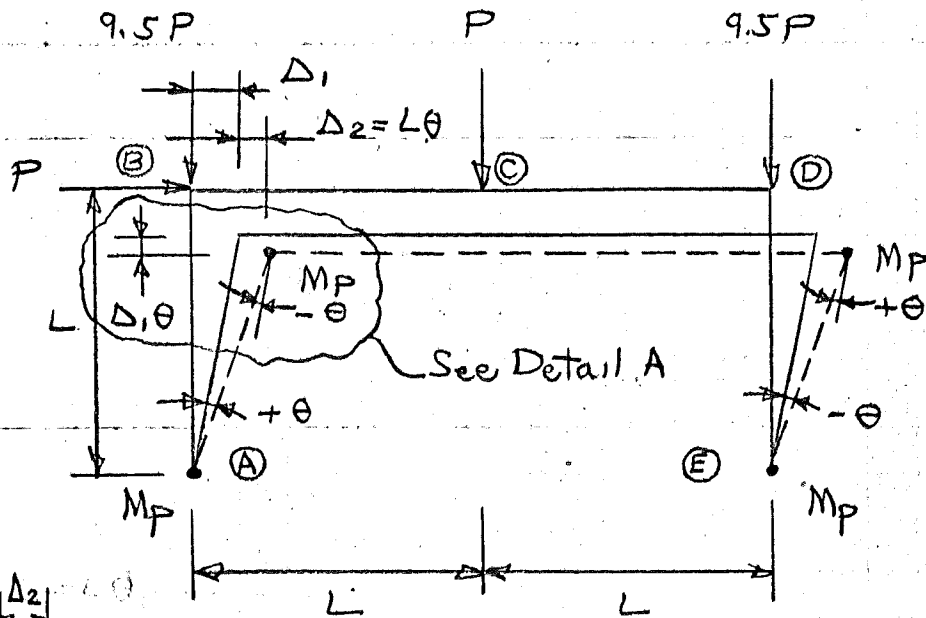

Assume θ_1 & θ_2 are small angles.
 ($\sin \theta = \theta$, $\cos \theta = 1$)

$$x_1 + x_2 = L[1 - \cos(\theta_1 + \theta_2)]$$

$$x_1 + x_2 = L\theta_1\theta_2$$

$$x_1 = L(1 - \cos \theta_1)$$

$$x_1 = 0$$

$$x_2 = (x_1 + x_2) - x_1 = L\theta_1\theta_2$$

$$x_2 = L\left(\frac{\Delta_1}{L}\right)(\theta) = \Delta_1\theta$$

$W_{ext.} = W_{int.}$

$$(P_{u2})(L\theta) + 2(9.5P)(\Delta_1\theta) = (M_{p\theta})(+\theta) + (-M_{p\theta})(-\theta) + (M_{p\theta})(+\theta) + (-M_{p\theta})(-\theta)$$

$$P_{u2} = \frac{1}{60} \times 10^6 = 0.016667 \times 10^6$$

Step 5. Repeat Steps (3) & (4) until convergence

(a) Moment diagram

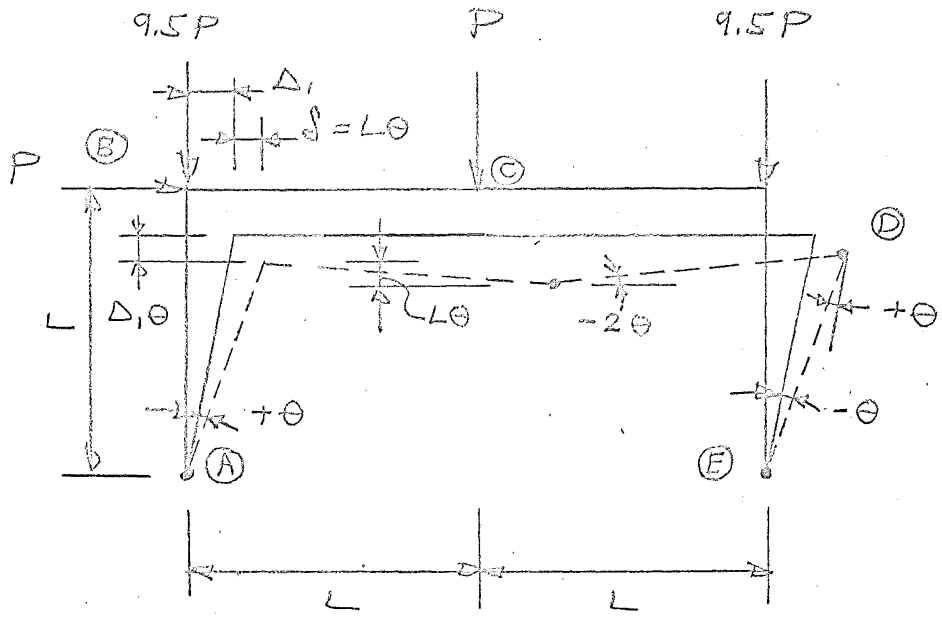

$$W_{ext} = W_{int}$$

$$(P_{M_2})(L\theta) + (19P_{M_2})(\Delta_1\theta) + (P_{M_2})(\Delta_1\theta + L\theta)$$

$$= (m_{FB})(+\theta) + m_{CD}(-2\theta) + (m_{PD})(+2\theta) + (-m_{FE})(-\theta)$$

$$\left(\frac{1 \times 10^6}{60}\right)(60) + (10)\left(\frac{1 \times 10^6}{60}\right)(9.0) = (2.0)(1 \times 10^6) - M_C$$

$$m_C = -0.500000 \times 10^6$$

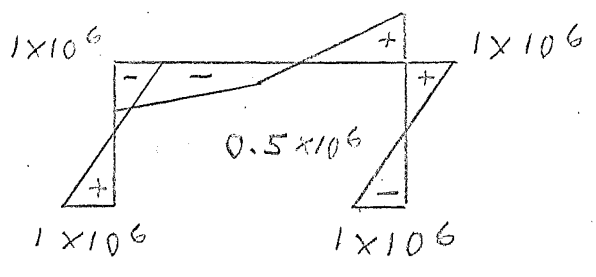

(b) Deflection

$$\frac{EI \Delta_2}{106} = \left[\begin{array}{c} 1.0 \\ \text{---} \\ 60 \end{array} \right] + \left[\begin{array}{c} 1.0 \\ \text{---} \\ 60 \end{array} \right] + \left[\begin{array}{c} 0.5 \\ \text{---} \\ 30 \end{array} \right]$$

$\leftarrow 60 \qquad \qquad \qquad \leftarrow 60 \qquad \qquad \qquad \leftarrow 60 \right.$

$$\Delta_2 = 1.0 + \left(\frac{1}{2}\right) [(2)(1.0 \times 2 + 0.5) + (2)(0.5) + 1.0] + \left(\frac{1}{2}\right)(2 \times 0.5 - 1.0)$$

$$\Delta_2 = 4.500000$$

Cycle 3

$$(60)P_{M_3} + (20)(4.50)P_{M_3} = 4 \text{ mp}$$
$$P_{M_3} = \frac{2 \times 10^6}{75} = 0.026667 \times 10^6$$

$$\left(\frac{2 \times 10^6}{75}\right)(60) + (10)\left(\frac{2 \times 10^6}{75}\right)(4.50) = (2.0)(1 \times 10^6) - M_{\odot}$$
$$M_{\odot} = -0.80 \times 10^6$$

$$\Delta_3 = 1.0 + \left(\frac{1}{2}\right) [(2)(1.0 \times 2 + 0.8) + (2)(0.8) + 1.0] + \left(\frac{1}{2}\right)(2 \times 0.8 - 1.0)$$

$$\Delta_3 = 5.400000$$

Check on change in P

$$\% \text{ change in } P = \frac{(0.026667 - 0.016667)(100)}{0.031215} = 32.0 \%$$

32.0% is greater than 1.0% allowed, therefore go on to next cycle

Cycle 4

$$(60)P_{u4} + (20)(5.4)P_{u4} = 4M_p$$
$$P_{u4} = \frac{1 \times 10^6}{42} = 0.023809 \times 10^6$$

$$\left(\frac{1 \times 10^6}{42}\right)(60) + (10)\left(\frac{1 \times 10^6}{42}\right)(5.4) = (2.0)(1 \times 10^6) - M_{\odot}$$

$$M_{\odot} = -0.714285 \times 10^6$$

$$\Delta_4 = 1.0 + \left(\frac{1}{2}\right) \left[(2)(1.0 \times 2 + 0.714285) + (2)(0.714285) + 1.0 \right]$$
$$+ \left(\frac{1}{2}\right) (2 \times 0.714285 - 1.0)$$

$$\Delta_4 = 5.142655$$

Check on change in P

$$\% \text{ change in } P = \frac{(0.026667 - 0.023809)(100)}{0.031215} = 9.2\%$$

9.2% is greater than 1.0% allowed, therefore go on to next cycle

Cycle 5

$$(60)P_{u5} + (20)(5.142655)P_{u5} = 4M_p$$
$$P_{u5} = 0.024562 \times 10^6$$

$$(0.024562 \times 10^6)(60) + (10)(0.024562 \times 10^6)(5.142655) = (2)(1 \times 10^6) - M_{\odot}$$
$$M_{\odot} = -0.736859 \times 10^6$$

$$\Delta_5 = 1.0 + \left(\frac{1}{2}\right) \left[(2)(1 \times 2 + 0.736859) + (2)(0.736859) + 1 \right] + \left(\frac{1}{2}\right) (2 \times 0.736859 - 1)$$

$$\Delta_5 = 5.212377$$

Check on change in P

$$\% \text{ change in } P = \frac{(0.024562 - 0.023809)(100)}{0.031215} = 2.4\%$$

2.4% is greater than 1.0% allowed, therefore go on to next cycle

Cycle 6

$$(60)P_{M6} + (20)(5.212377)P_{M6} = 4M_p$$

$$P_{M6} = 0.024358 \times 10^6$$

$$(0.024358 \times 10^6)(60) + (10)(0.024358 \times 10^6)(5.212377) = (2)(1 \times 10^6) - M_{\odot}$$

$$M_{\odot} = -0.731111 \times 10^6$$

$$\Delta_6 = 1.0 + \left(\frac{1}{2}\right) \left[(2)(1 \times 2 + 0.731111) + (2)(0.731111) + 1 \right] + \left(\frac{1}{2}\right) (2 \times 0.731111 - 1)$$

$$\Delta_6 = 5.193333$$

Check on change in P

$$\% \text{ change in } P = \frac{(0.024562 - 0.024358)(100)}{0.031215} = 0.7\%$$

0.7% is less than 1.0% allowed, therefore

$$P_{M6} = P_u \text{ and } \Delta_6 = \Delta_u$$

$$P_u = 0.024358 \times 10^6$$

$$\Delta_u = 5.193333$$

Step 6. Checks

(a) Check for correct assumed mechanism

∴ Moment diagram :

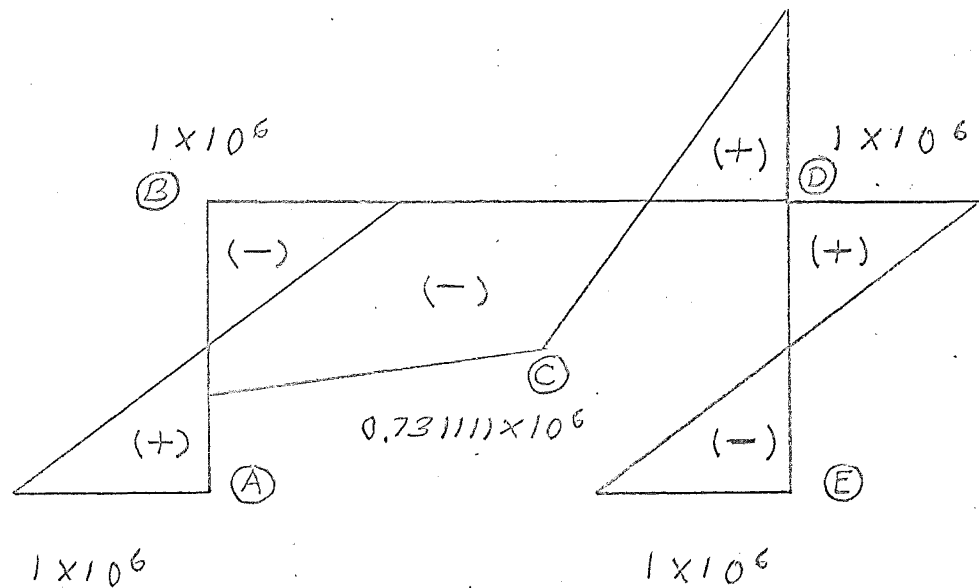

No moment is greater than $M_p = 1 \times 10^6$, therefore original assumption for failure mechanism is correct

(b) Check for correct assumed last hinge

Note - In this example there is no question as to the correct last hinge since only one hinge of the correct mechanism has not been developed by the stable range iteration. However, to demonstrate the complete paper the necessary calculations for the general case will be shown.

(1) Simultaneous equations

number of redundents = $R = 3$

Equilibrium Structure (a)

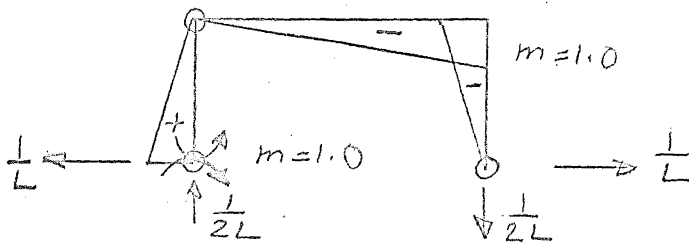

$$0 = (\ominus \oplus)(1) + (\ominus \oplus)(-1) + \frac{1}{EI} \int Mm dx$$

$$\frac{1}{EI} \int Mm dx = (10^6) \left[\begin{array}{c} 1.0 \\ 1.0 \end{array} \begin{array}{c} \text{triangle} \\ \text{triangle} \end{array} \begin{array}{c} 1.0 \\ 1.0 \end{array} \right] + \left[\begin{array}{c} 1.0 \\ 1.0 \end{array} \begin{array}{c} \text{triangle} \\ \text{triangle} \end{array} \begin{array}{c} 0.731111 \\ 0.500000 \end{array} \right] + \left[\begin{array}{c} 0.731111 \\ 0.500000 \end{array} \begin{array}{c} \text{triangle} \\ \text{triangle} \end{array} \begin{array}{c} 1.0 \\ 1.0 \end{array} \right] \\ + \left[\begin{array}{c} 1.0 \\ 1.0 \end{array} \begin{array}{c} \text{triangle} \\ \text{triangle} \end{array} \begin{array}{c} 1.0 \\ 1.0 \end{array} \right]$$

$$\frac{1}{EI} \int Mm dx = (10^6) \left[\left(\frac{1}{6} \right) (1)(1)(60) + \left(\frac{1}{6} \right) (0.50)(2 \times 0.731111 + 1.0)(60) + \left(\frac{1}{6} \right) [2(0.50 \times 0.731111) - 1.0 \times 1.0] + 1.0 \times 0.731111 - 0.50 \times 1.0 \right] (60) + \left(\frac{1}{6} \right) (1)(-1)(60) \right]$$

$$\ominus \oplus - \ominus \oplus + 1.933340 = 0$$

Equilibrium Structure (b)

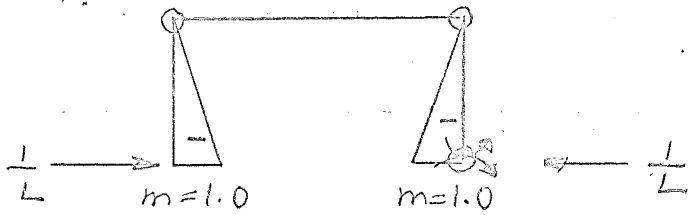

$$0 = (\ominus_A)(-1) + (-\ominus_B)(-1) + \frac{1}{EI} \int Mm d\alpha$$

$$\frac{1}{EI} \int Mm d\alpha = (10^6) \left[\begin{array}{c} \text{1.0} \begin{array}{c} \nearrow \\ \searrow \end{array} \text{1.0} \\ \text{1.0} \begin{array}{c} \searrow \\ \nearrow \end{array} \text{1.0} \end{array} \right] + \left[\begin{array}{c} \text{1.0} \begin{array}{c} \searrow \\ \nearrow \end{array} \text{1.0} \\ \text{1.0} \begin{array}{c} \nearrow \\ \searrow \end{array} \text{1.0} \end{array} \right]$$

$$\frac{1}{EI} \int Mm d\alpha = (10^6) \left[\left(\frac{1}{6}\right)(-1.0)(1.0)(60) + \left(\frac{1}{6}\right)(1.0)(1.0)(60) \right]$$

$$\ominus_A - \ominus_B = 0$$

Equilibrium Structure (c)

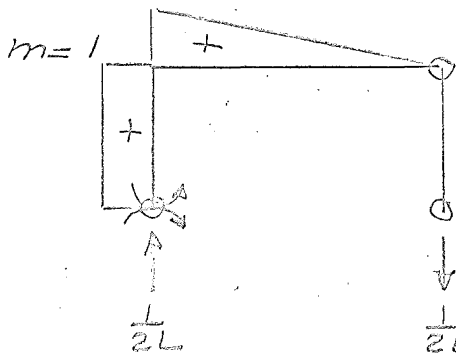

$$0 = (\ominus_A)(1) + (-\ominus_B)(1) + \frac{1}{EI} \int Mm d\alpha$$

$$\frac{1}{EI} \int Mm d\alpha = (10^6) \left[\begin{array}{c} \text{1.0} \begin{array}{c} \searrow \\ \nearrow \end{array} \text{1.0} \\ \text{1.0} \begin{array}{c} \nearrow \\ \searrow \end{array} \text{1.0} \end{array} \right] + \left[\begin{array}{c} \text{1.0} \begin{array}{c} \searrow \\ \nearrow \end{array} \text{0.731111} \\ \text{1.0} \begin{array}{c} \nearrow \\ \searrow \end{array} \text{0.500000} \end{array} \right] + \left[\begin{array}{c} \text{0.731111} \begin{array}{c} \nearrow \\ \searrow \end{array} \text{1.0} \\ \text{0.500000} \begin{array}{c} \searrow \\ \nearrow \end{array} \text{1.0} \end{array} \right]$$

$$\frac{1}{EI} \int Mm d\alpha = (10^6) \left[(0) - \left(\frac{1}{6}\right) \left[2(1 \times 1 + 0.731111 \times 0.50) + 0.731111 \times 1 + 1 \times 0.5 \right] (60) \right. \\ \left. + \left(\frac{1}{6}\right) (0.57) (-2 \times 0.731111 + 1) (60) \right]$$

$$\ominus_A - \ominus_B - 41.933330 = 0$$

(2) Solving equations

Let $\theta_A = 0$: (assume last hinge forms at A)

(a) $\theta_A - \theta_D + 1.933340 = 0$

$0 - \theta_D + 1.933340 = 0$

$\theta_D = 1.933340$

(b) $\theta_A - \theta_E = 0$

$0 - \theta_E = 0$

$\theta_E = 0$

(c) $\theta_A - \theta_B - 41.933330 = 0$

$0 - \theta_B - 41.933330 = 0$

$\theta_B = -41.933330$

Let $\theta_B = 0$: (assume last hinge forms at B)

(c) $\theta_A = 41.933330$

(b) $\theta_E = 41.933330$

(a) $\theta_D = 43.866670$

Let $\theta_D = 0$: (assume last hinge forms at D)

(a) $\theta_A = -1.933340$

(b) $\theta_E = -1.933340$

(c) $\theta_B = -43.866670$

Let $\theta_E = 0$: (assume last hinge forms at E)

(b) $\theta_A = 0$

(c) $\theta_B = -41.933330$

(a) $\theta_D = 1.933340$

(3) Correct last hinge is at B since no θ_D is equal to a minus value

Plot of Elastic - Plastic Load - Deflection Curve

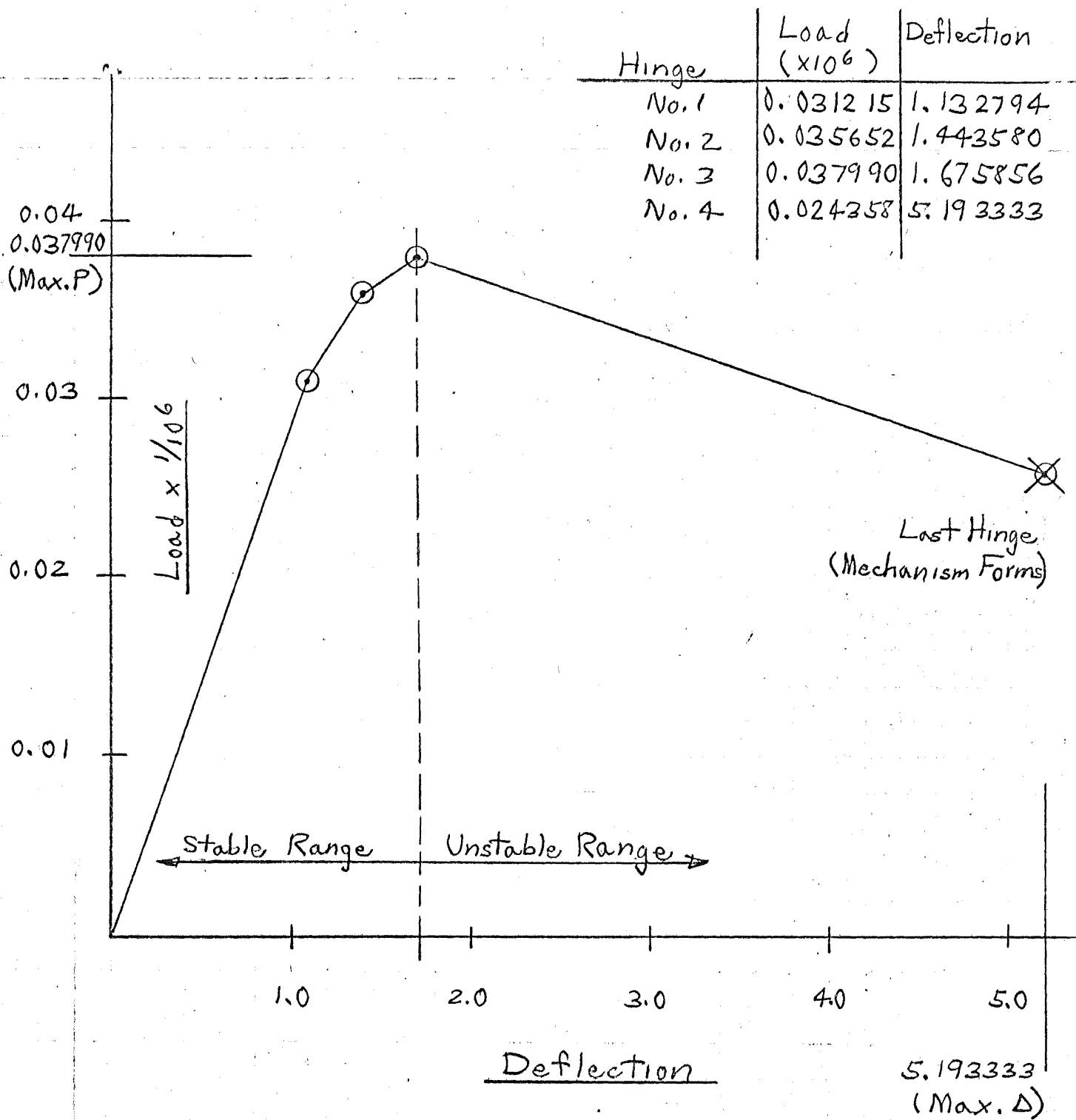

6. REFERENCES

1. American Society of Civil Engineers
PLASTIC DESIGN IN STEEL, Commentary on, Manuals of
Engineering Practice Number 41, 1961
2. Beedle, L. S.
PLASTIC DESIGN OF STEEL FRAMES, John Wiley and Sons,
New York, 1958
3. Lehigh University
PLASTIC DESIGN OF MULTI-STORY FRAMES, Fritz
Engineering Laboratory Report No. 273.20, Bethlehem,
Pennsylvania, 1965
4. Vogel, U.
DIE TRAGLASTBERECHNUNG STAHLERNER RAHMEN TRAGWERKE NACH
DER PLASTIZITÄTSTHEORIE II. ORDNUNG, Heft 15,
Stahlbauverlag, Köln, 1965
5. Horne, M. R.
STABILITY OF ELASTIC-PLASTIC STRUCTURES, Progress in
Solid Mechanics, Edited by Sneddon & Hill, Vol. 2,
North Holland Publ. Co., Amsterdam, 1961
6. Parikh, B. P.
ELASTIC-PLASTIC ANALYSIS AND DESIGN OF UNBRACED MULTI-
STORY STEEL FRAMES, Fritz Engineering Laboratory Report
No. 273.44, May, 1966
7. Crandall, S. H. and Dahl, N. C.
AN INTRODUCTION TO THE MECHANICS OF SOLIDS, McGraw-Hill
Book Company, Inc., New York, 1959
8. Heyman, J.
ON ESTIMATION OF DEFLECTIONS IN ELASTIC-PLASTIC FRAMED
STRUCTURES, Proc. Inst. C.E., Vol. 19, May, 1961, p. 39-60
Discussion by Martin, J. B.
Proc. Inst. C.E., Vol. 23, Oct. 1962, p. 303-308